

PARABODY

Serious Steel

827103

LAT MACHINE

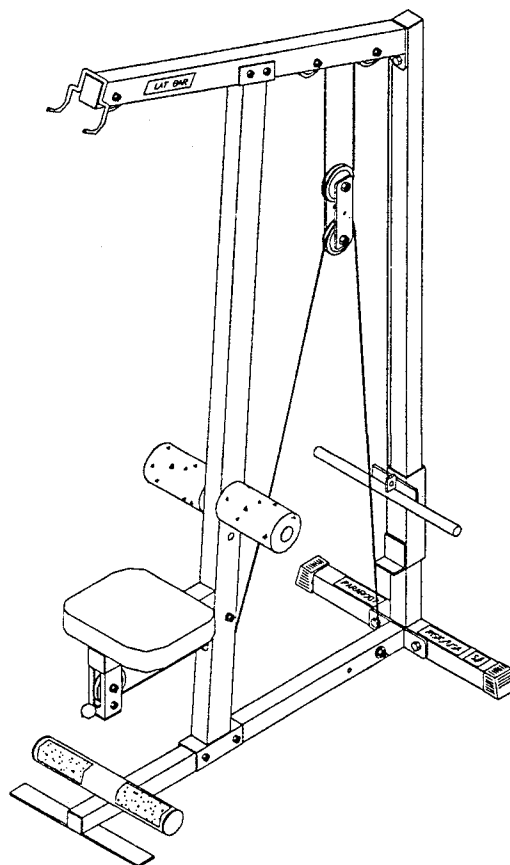

ASSEMBLY
INSTRUCTIONS

PART# 6665201

1

REVISION 11/27/96

827103 LAT MACHINE ASSEMBLY INSTRUCTIONS

SORT AND COUNT ALL PARTS BEFORE BEGINNING ASSEMBLY

HARDWARE:

ITEM	NAME/DESCRIPTION	QTY
1.	3/8 IN WASHER	3
2.	1/2 IN WASHER	4
3.	3/8 IN LOCK WASHER	2
4.	1/2 IN LOCK WASHER	1
5.	3/8 IN LOCK NUT	13
6.	1/2 IN LOCK NUT	3
7.	3/8 X 2 IN BOLT	2
8.	1/2 X 3 IN BOLT	4
9.	3/8 X 2-3/4 IN BOLT	12
10.	3/8 X 3-1/4 IN BOLT	1
11.	SNAPHOOK	3
12.	QUICKLINK	1
13.	3/8" STEP SPACER	10
14.	CHAIN	1
15.	2-1/2" OD END CAP	2
16.	3-1/2 OD X 3/8 ID PULLEY	7
17.	CABLE ASSEMBLY	2
18.	3 X 2 IN END CAP	1
19.	1-1/4 IN RUBBER BUMPER	1
20.	1 X 8" GRIP	4
21.	CARRIAGE GLIDE 1 X 1	8
22.	2-1/2 X 5-1/2" NON SKID STRIP	2
23.	3/8 ID X 5 IN VINYL CAP	2
24.	2 SQ. END CAP	4
25.	2 SQ. COVER CAP	2
26.	9/16 OD MUSHROOM CAP	2

WELDMENTS/PARTS:

ITEM	NAME/DESCRIPTION	QTY
1.	BASE WELDMENT (6540903)	1
2.	REAR UPRIGHT WELDMENT (6512003)	1
3.	WEIGHT CARRIAGE WELDMENT (6546303)	1
4.	FRONT UPRIGHT WELDMENT (6541103)	1
5.	LAT BAR WELDMENT (6275302)	1
6.	LOW ROW BAR WELDMENT (6274402)	1
7.	BOOM WELDMENT (6511303)	1
8.	PAINTED CONNECTOR (6542403)	2
9.	SEAT PAD (6664802)	1
10.	4 X 7" ROLLER PAD (6194601)	2
11.	ROLLER PAD SHAFT (6485301)	1

827103 LAT MACHINE ASSEMBLY INSTRUCTIONS

NOTE: BOLT LENGTH IS MEASURED FROM THE UNDERSIDE OF THE HEAD OF THE BOLT.

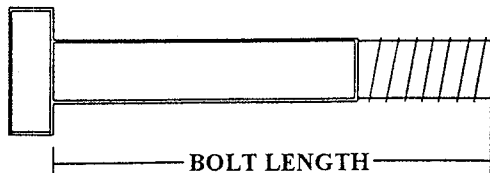

BOLT LENGTH RULER:

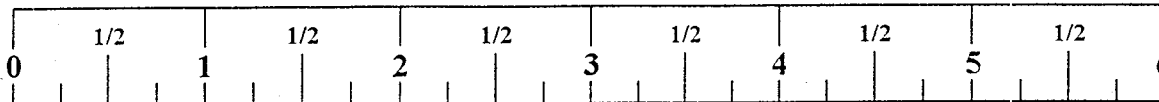

THANK YOU

FOR PURCHASING THE *827103 LAT MACHINE*. PLEASE SAVE THESE ASSEMBLY INSTRUCTIONS FOR YOUR PERSONAL REFERENCE, AND ADDITIONAL SERVICE INFORMATION.

IMPORTANT

- THE *827103 LAT MACHINE* MUST BE ASSEMBLED ON A FLAT, LEVEL SURFACE TO ASSURE ITS PROPER FUNCTION.
- IF YOU EXPERIENCE ANY PROBLEM WITH THE ASSEMBLY OF THIS PRODUCT, PLEASE CONTACT YOUR DEALER OR YOUR PARABODY CUSTOMER SERVICE REPRESENTATIVE AT: 1-800-328-9714.
- TOOLS REQUIRED: RATCHET, 3/4 SOCKET or WRENCH, 9/16 SOCKET or WRENCH, ADJUSTABLE WRENCH, and RUBBER MALLET or HAMMER.

1. Insert one (1) 2" END CAP and two (2) 2-1/2" OD END CAPS into the open ends of the BASE.
2. Apply two (2) 2-1/2" X 5-1/2" NON SKID STRIPS to the BASE as shown on drawing.
3. Insert two (2) 2" END CAPS into the open ends of the FRONT UPRIGHT.
4. Insert one (1) 3 X 2" END CAP into front end of the BOOM and slide two (2) 3/8 ID X 5" VINYL CAPS over lat bar hooks.
5. Insert one (1) 2" END CAP into the top of the REAR UPRIGHT. Install two (2) 2" COVER CAPS over the bottom ends of the REAR UPRIGHT.
6. Assemble two (2) 4 X 7" ROLLER PADS to the FRONT UPRIGHT using one (1) ROLLER PAD SHAFT and two (2) MUSHROOM CAPS.

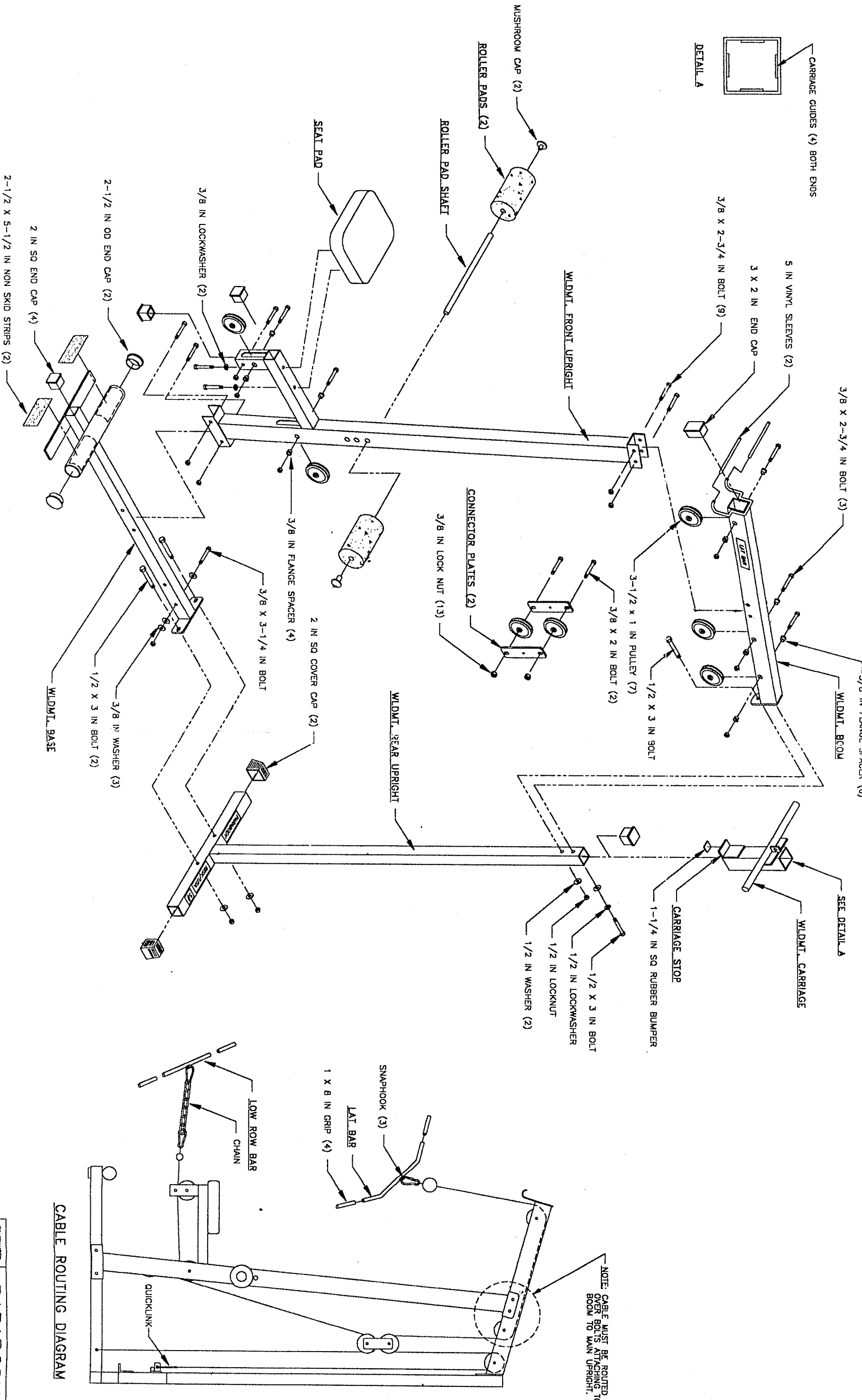

TOLERANCES (UNLESS OTHERWISE SPECIFIED)

FRONT VIEW	
TOP VIEW	
RIGHT SIDE VIEW	
LEFT SIDE VIEW	
END VIEW	
SECTION	
SCALE	
DATE	
BY	
CHKD	
APP'D	
DATE	

TITLE: PARABODY, INC.
 RAMSEY, MINNESOTA
 ASSY INST. 827103
 SHEET 1 OF 1
 66652
 11/74