

Owner's Manual

X-30

MULTITRACKER



Fostex

SAFETY INSTRUCTIONS

WARNING READ BEFORE OPERATING

1. Read Instructions—All the safety and operating instructions should be read before the appliance is operated.
2. Retain Instructions—The safety and operating instructions should be retained for future reference.
3. Heed Warnings—All warnings on the appliance and in the operating instructions should be adhered to.
4. Follow Instructions—All operating and use instructions should be followed.
5. Water and Moisture—The appliance should not be used near water—for example, near a bathtub, wash-bowl, kitchen sink, laundry tub, in a wet basement, or near a swimming pool, etc.
6. Ventilation—The appliance should be situated so that its location or position does not interfere with its proper ventilation. For example, the appliance should not be situated on a bed, sofa, rug, or similar surface that may block the ventilation openings; or, placed in built-in installation, such as a bookcase or cabinet that may impede the flow of air through the ventilation openings.
7. Heat—The appliance should be situated away from heat sources such as radiators, heat registers, stoves, or other appliances (including amplifiers) that produce heat.
8. Power Sources—The appliance should be connected to a power supply only of the type described in the operating instructions as marked on the appliance.
9. Power-Cord Protection—Power-supply cords should be routed so that they are not likely to be walked on or pinched by items placed upon or against them, paying particular attention to cords at plugs, convenience receptacles, and the point where they exit from the appliance.
10. Cleaning—The appliance should be cleaned only as recommended by the manufacturer.
11. Nonuse Periods—The power cord of the appliance should be unplugged from the outlet when left unused for a long period of time.
12. Object and Liquid Entry—Care should be taken so that objects do not fall and liquids are not spilled into the enclosure through openings.

TABLE OF CONTENTS

13. Damage Requiring Service—The appliance should be serviced by qualified service personnel when:
- A. The power-supply cord or the plug has been damaged: or
 - B. Objects have fallen, or liquid has been spilled into the appliance: or
 - C. The appliance has been exposed to rain: or
 - D. The appliance does not appear to operate normally or exhibits a marked change in performance: or
 - E. The appliance has been dropped, or the enclosure damaged.
14. Servicing—The user should not attempt to service the appliance beyond that described in the operating instructions. All other servicing should be referred to qualified service personnel.

WARNING: *To avoid possible electric shock hazard, do not expose this appliance to rain or moisture. There are no user serviceable parts inside. Refer servicing to qualified service personnel.*

Section 1	Instructions	2
Section 2	The Controls and Their Functions	3
Section 3	Signal Flow Diagram	9
Section 4	Recording Procedure (Fundamental steps)	12
Section 5	Ping-pong Recording	22
Section 6	Recording Procedures (Special techniques)	25
Section 7	Trouble Shooting	34
Section 8	Specifications	36
Section 9	Block Diagram	37

SECTION 1

INTRODUCTION

The X-30 personal multitracker is like a personal computer in two respects. First, it may be used for business or pleasure, or both; second, and most important, what you get out of it depends on what you put into it.

4-track cassette recorder/mixers have been available for some time now, Popular records, commercial jingles and even soundtracks have been produced with these devices.

You won't have to become an engineer in order to make good tapes with the X-30. You will have to learn a few fundamentals about recording (if you don't know), which controls to use, and in what sequence.

The importance of good microphones can't be stressed hard enough. The "garbage in, garbage out" computer axiom applies here as well.

If you are familiar with recording practices in general and multitrack techniques in particular, pages 12 through 33 and the block diagram on page 37 should tell you most of what you'll need to know about the X-30.

If you're just getting started, you couldn't have picked a better multitracker than the X-30. Please read all the operating instructions carefully. They will give you a solid base from which to grow and experiment.

Your X-30 will perform all the normal functions of a standard Hi-Fi cassette deck, in addition to multitrack techniques, so presumably not everything is new or unfamiliar.

The information in the manual is presented in the sequence normally followed in making a multitrack master. The initial recording (reference track), overdubbing and mixdown.

Following these topics, we cover ping-pong recording, punching-in/out and other related procedures.

Most operating procedures are organized step-by-step. Accompanying diagrams are labelled to show the controls associated with the numbered steps.

It is likely that none of your actual recording situations will be duplicated exactly in the examples which follow. But they are not arbitrary examples. Collectively, they are intended to show the versatility of the X-30, while emphasizing its ease of use.

Finally, a note about cassette tape. Your X-30 is set up (factory biased and equalized) for high bias, 70 μ sec EQ, C-60s or C-90s only TDK—SA, Maxell - XL-II or equivalent.

The four tracks all move in the same direction, of course, so your recording time is about 30 minutes on a C-60 and 45 minutes on a C-90.

THE CONTROLS AND THEIR FUNCTIONS

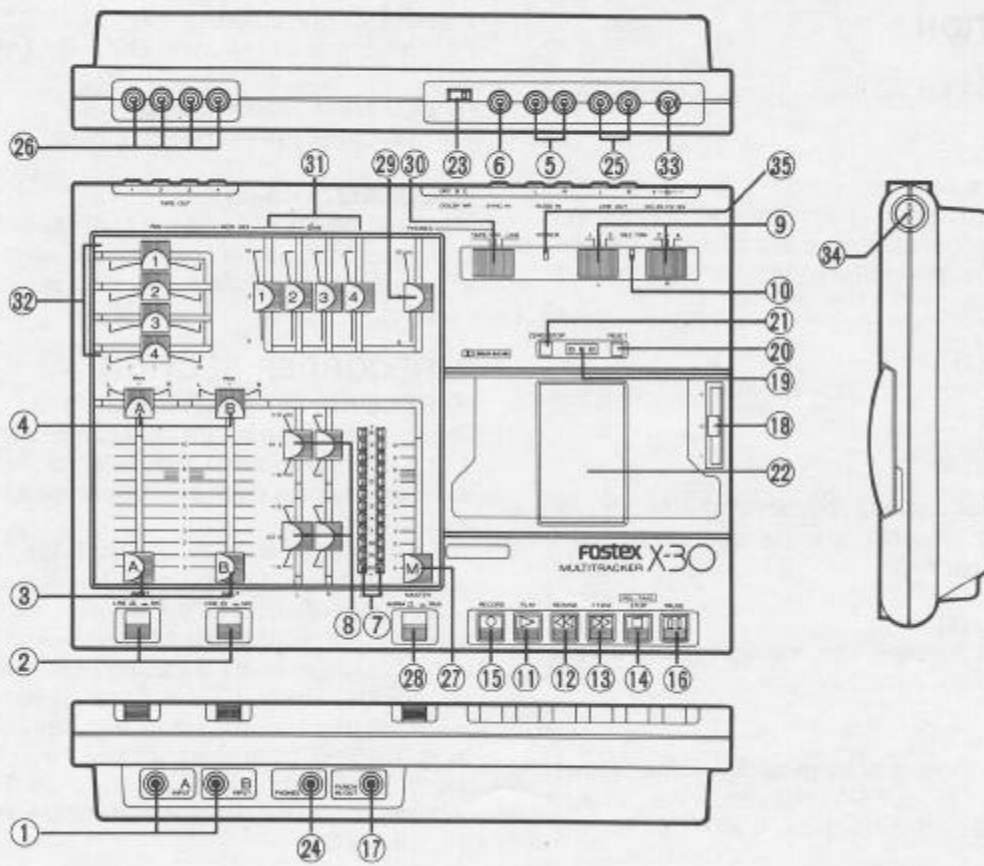

LED \ Item	Mode at Punch in/out	Condition of the recorder and its meaning
No light	Take	Indicates no track in record mode.
Dim red glow	Take	Indicates record standby state at which REC button is pressed but REC TRK is not selected or it is in REC/PAUSE.
Bright red	Take	Indicates there is a track in record mode.
Green light	Rehearsal	Punch out state.
Amber light	Rehearsal	Indicates punch in mode but not recording(input monitor mode).

⑩ RECORD (REC TRK) LED

Five lighting patterns of LED: indicates conditions of the recorder by the LED's in red, green, amber, dim red, and off.

For details, refer to "Rehearsal and take at punch-in/out", page 17 and the schematic on method of punch-in/out on page 20.

⑪ PLAY button

Pressing this button puts the X-30 into normal playback operation and may be engaged from either fast wind mode or from the stop mode. While in the PLAY mode, depressing either REWIND ⑫ or F. FWD ⑬ will let you hear what is on the tape but at higher speed than normal. You'll soon get used to this high speed cueing technique and should find it helpful in locating selections on a tape.

⑫ REWIND button

⑬ F.FWD button

These buttons are for high speed tape motion and the arrows indicate the direction of travel. You cannot enter the record mode from the high speed mode. In the high speed mode the tape will automatically stop at the end of the winding.

⑭ Stop button (RSL/TAKE)

- 1) Functions as the STOP button during transporting of tape.
- 2) Functions as the RSL/TAKE button when recorder is stopped.

RSL/TAKE means 'rehearsal/take.' As shown in the drawing, while this button is held down with the recorder stopped, the punch-in/out mode will alternate between rehearsal mode (REC LED: green is lit) and take mode (REC LED: extinguished) each time the foot switch plugged into the PUNCH-IN/OUT jack ⑰ is pressed.

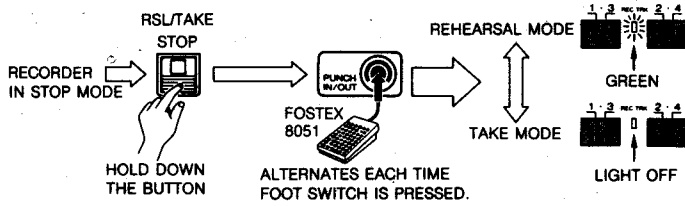

⑮ RECORD button

There are three ways to enter the record mode after the REC TRK selectors ⑨ have been set:

1. Press RECORD.
2. Press PLAY ⑪, then press RECORD.
3. Press PAUSE ⑯ then press RECORD; rehearse and set the levels properly, then press PAUSE a second time to begin recording. This procedure is recommended as typical.

⑯ PAUSE button

When the X-30 is in either PLAY mode ⑪ or RECORD mode ⑮, pressing the PAUSE button stops tape travel. Pressing the PAUSE button a second time resumes tape travel.

⑰ PUNCH-IN/OUT jack

This jack accepts the Fostex Model 8051 optional remote foot control for punching in and punching out.

⑱ PITCH control

Normal tape speed of 4.8 cm/s (1-7/8 ips) can be changed within a continuously variable range of $\pm 15\%$ by sliding this knob. There are several uses for this control. It can help you "tune" various musical instruments to each other, as well as adjust other tapes to the tuning of your musical instruments. It can help you get vocals to "ring" in perfect harmony. Plus, you can use the PITCH control as a creative device for generating new

distinctive sounds.

NOTE: Always return the *PITCH* control to its center click position after using it.

⑱ ⑳ TAPE COUNTER & RESET button

This three digit counter is useful as an approximate reference for the beginning of the recording (000). Press the RESET button at the right side of the counter to set the 000 reference.

㉑ ZERO STOP button

When this button is pressed in advance, the recorder will enter the STOP mode from the REWIND mode upon reaching the 000 position.

(It will not enter the STOP mode during the play, record, and F.FWD modes.)

㉒ TAPE TRANSPORT

㉓ Dolby NR switch

The 4 channels are simultaneously selected for Dolby C or B settings and NR off, by this switch.

3. OUTPUT SECTION

㉔ PHONES (stereo jack)

Use a stereo headphone set with an impedance of 8 ohms through 40 ohms. Like microphones, headphones are specified with an impedance that tells you which con-

nections make for best sonic results.

㉕ LINE OUT jacks (L and R)

The signal present at these jacks is the stereo mix determined either by the settings of the MONMIX controls ㉓ ㉔, or by the settings of the main level control ㉗ and equalizers ㉘.

㉖ TAPE OUT jacks (4)

These jacks are numbered 1 through 4 and correspond to the tracks on the recorder.

In the PLAY mode, these jacks carry the playback signal from the tape. In the record mode (also record/pause mode), or rehearsal mode, these jacks carry the input signal.

㉗ MASTER fader

This is a ganged pot which controls the overall level of the L/R output channels, as well as the level of the signals sent to the recorder.

㉘ NORMAL/RMX (Remix) selector

In the Up (NORM) position, input signals are sent simultaneously to the recorder and to the L/R output channels. In the Down (RMX) position, signals from the four tape tracks are sent to the 4 x 2 MONMIX section ㉓ ㉔ and then mixed with the L/R output channels.

㉙ PHONE level control

③① MONITOR selector (TAPE/MIX/LINE)











This selects the signal sent to the headphones.

TAPE: Tape sound mixed by MONMIX ③①, ③② only will be heard. The setting for take at overdubbing.

MIX: The mixed signals or TAPE and LINE is heard. The setting for rehearsal at overdubbing.

LINE: Output signal to the stereo buss is heard. The setting for mixdown and ping-pong recording.

Positions of NORM/RMX selector ②⑧ and MONITOR selector ③① in accordance to operating modes are listed below.

		NORM / RMX	MONITOR
Standard recording		 NORM	
Overdubbing	Rehearsal	 NORM	
	Take	 NORM	
Ping-Pong recording		 RMX	
Mixdown (Standard playback)		 RMX	

4. MONMIX SECTION

③① ③② GAIN and PAN pots (4)

Each group of two faders is numbered 1 through 4 to correspond with the tracks on the tape.

③① are the GAIN controls and ③② are the PAN controls. The 4 tracks are thus mixed to stereo (LINE OUT).

③③ DC power supply input jack for the Fostex Model AD-12 AC adaptor.

③④ POWER switch

③⑤ POWER indicator

This POWER indicator is lit when the POWER switch ③④ is turned on while DC current is being supplied from AD-12 AC power adaptor.

SECTION 3

SIGNAL FLOW DIAGRAM

You should have a clear understanding of the signal flow in relation to various operations of the X-30 controls by referring to the following diagrams.

Example 1

Signal flow of a synthesizer connected to INPUT jack A for recording on track 1.

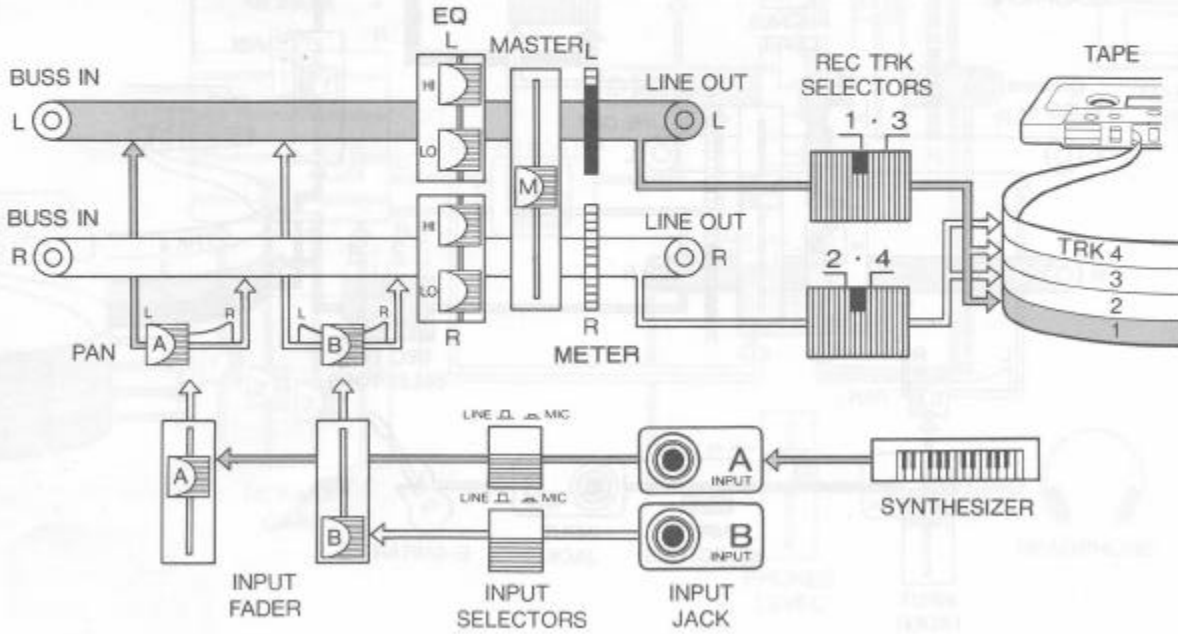

Example 2

Signal flow when overdubbing an electric guitar on track 2 while listening to track 1 (synth).

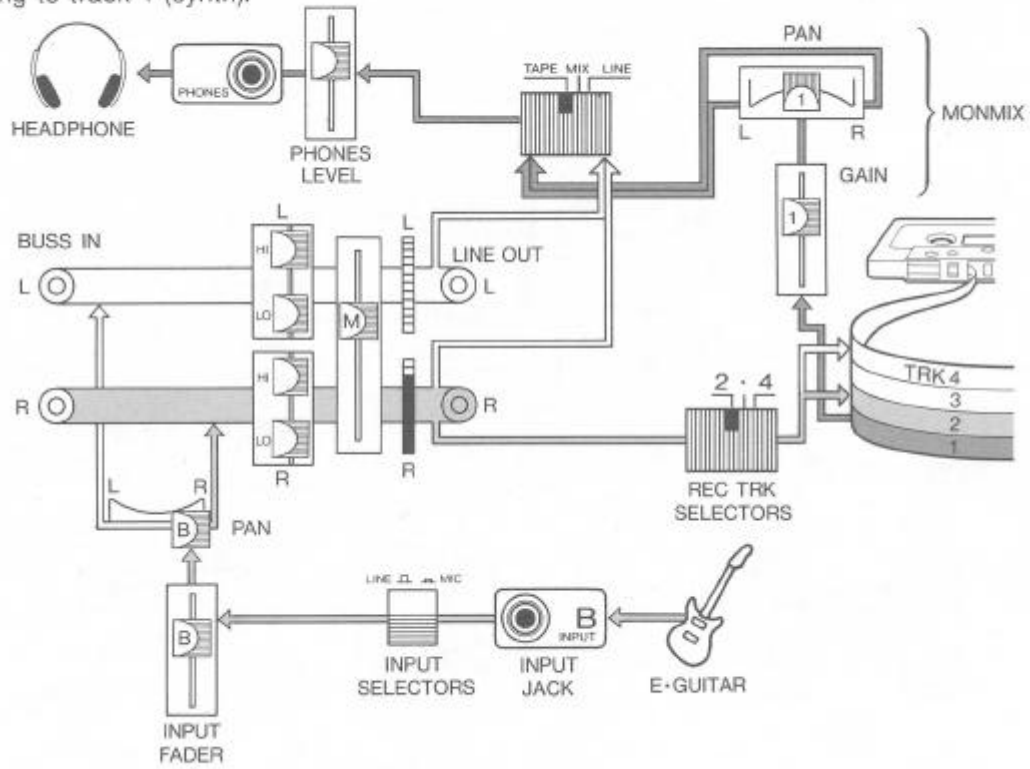

Example 3

Signal flow at mixdown.

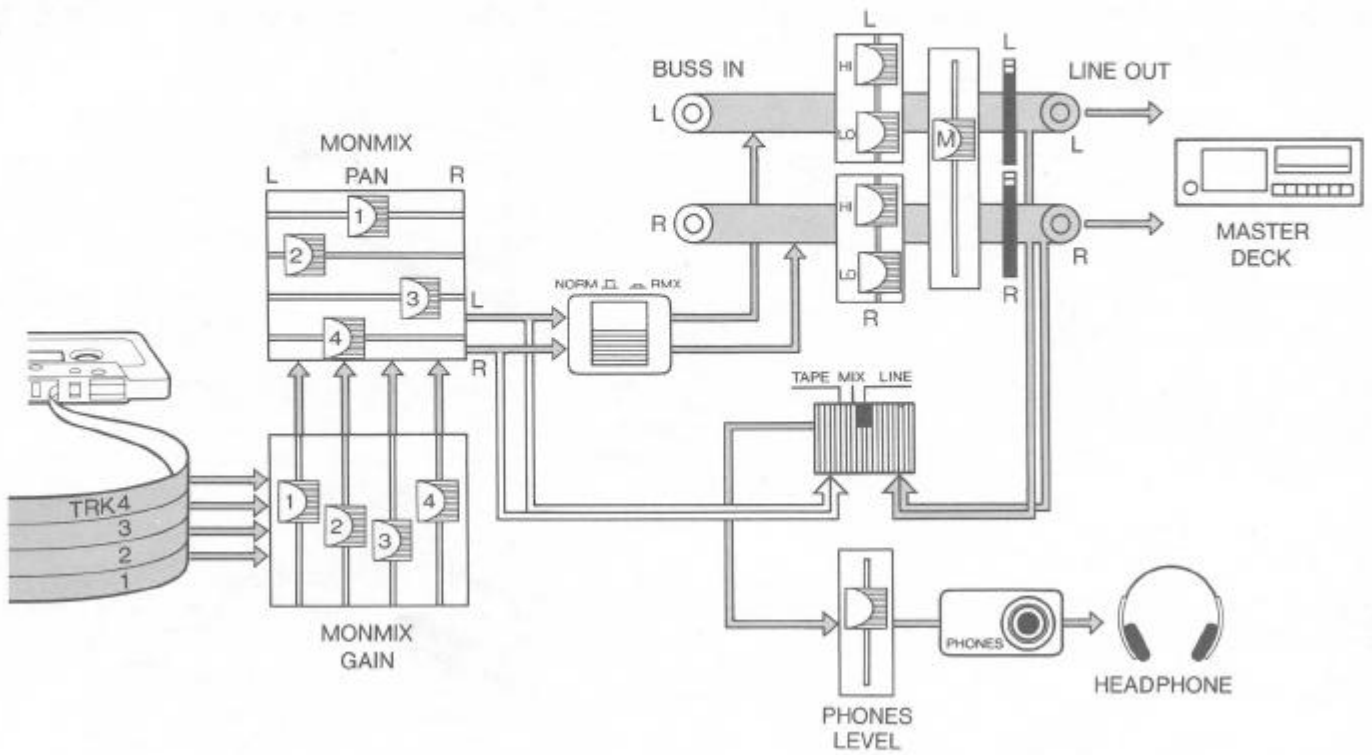

SECTION 4

Recording procedure (Fundamental steps)

"The stereo buss"

The two thick lines in the diagrams of the previous Examples 1 ~ 3, (BUSS IN to LINE OUT) the "stereo buss." It is something like a "trunk line" which carries various individual signals.

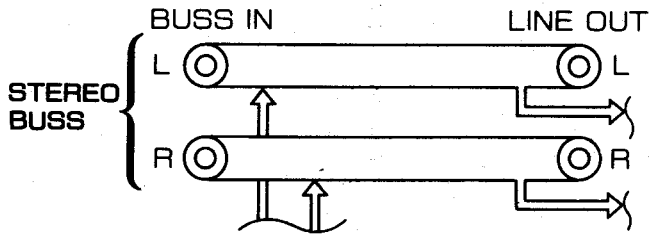

The basic techniques in multitrack recording are explained by the step-by-step procedure diagrams below.

Step 1 A rhythm track is made by recording a drum machine on track 1.

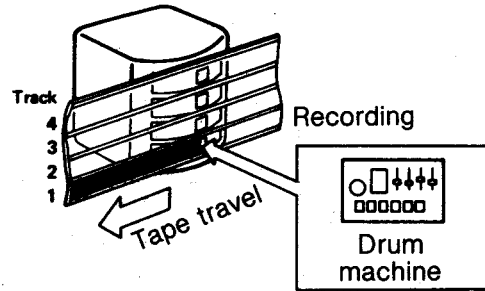

Step 2-1 An electric bass is overdubbed on track 2.

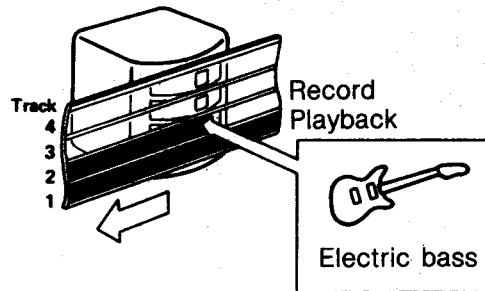

Step 2-2 & 3 (Further overdubbing)

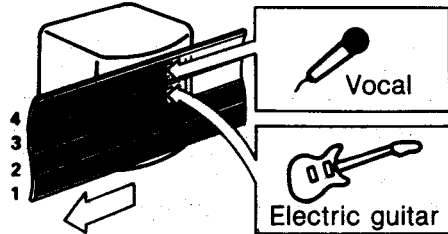

Step 3 A mistake in the electric guitar part is replaced by punching-in/out.

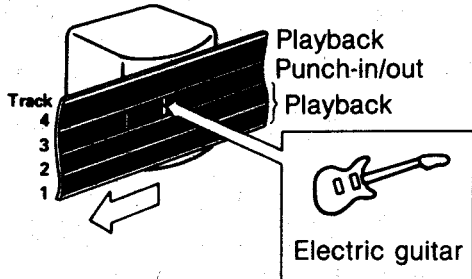

Step 4 Mixdown

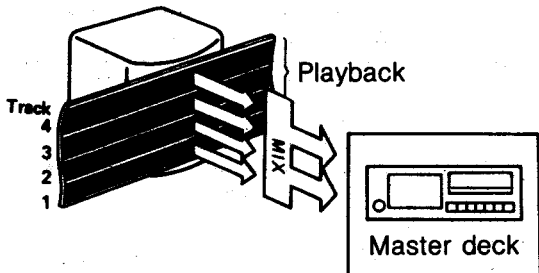

Procedure 1 Producing the basic rhythm track (Recording the drum machine on track 1)

* Before proceeding to the steps below, be sure the REC TRK LED is extinguished. If it is lit, extinguish it by referring to page 6.

1. Plug the drum machine line output into an INPUT jack (In this case, it is plugged into channel A)
2. Set the channel A INPUT selector to LINE.
3. Set the REC TRK selector ⑨ L side to 1 and slide PAN A to full left.

The drum machine output can now be sent to track 1. Next, set the recording level.

4. Set the MASTER fader at about 7 or 8, start the drum machine and slowly raise INPUT fader A from its zero position. The L (left side) meter will gradually indicate a higher reading. Set a maximum reading of about +3.

If the level is low even though INPUT fader A is raised near maximum, return it to zero, set the INPUT selector to MIC and repeat the above procedure.

5. Monitor (listen to) this sound. After setting the PHONES level control pot to zero, plug in a headset into the PHONES jack.
6. Set the MONITOR selector to LINE or MIX, and you will begin to hear the sound as you raise the PHONES level control pot. If necessary, alter the tone by the Chan. L EQ, then readjust the level by the INPUT fader A (Sound is heard only from the left earphone).

7. Now before recording, stop the drum machine and press the RESET button to return the tape counter to 000. Next, the NORM/RMX selector and MONITOR selector are set by referring to the chart on page 8. The setting, in this case, is "Normal recording."
8. The MONMIX GAIN 1 is set to 6 or 7, the MONMIX PAN 1 set to center, and put the recorder in the RECORD mode by pressing RECORD button (REC TRK LED will be lit in bright red). Then, when the drum machine is started, the sound will be heard in its designated center position. As the placement can be freely shifted by MONMIX PAN 1, and the sound volume by MONMIX GAIN 1, try for several different settings (The recording level will not be affected.).
9. Rewind tape upon finishing the performance. If the ZERO STOP button had been pressed in advance, the tape will automatically stop at the 000 position.

Procedure 2-1 Overdubbing the electric bass onto track

What is overdubbing?

The process of recording a new sound onto a separate track (track 2 in this case) while monitoring the previously recorded track (track 1 in this case) and in sync with it, is called "Overdubbing." This "Overdub" is an indispensable technique in multitrack recording.

First rehearse (perform in sync with the monitored sound but do not record). After practicing to your satisfaction, you're ready for recording or "the take."

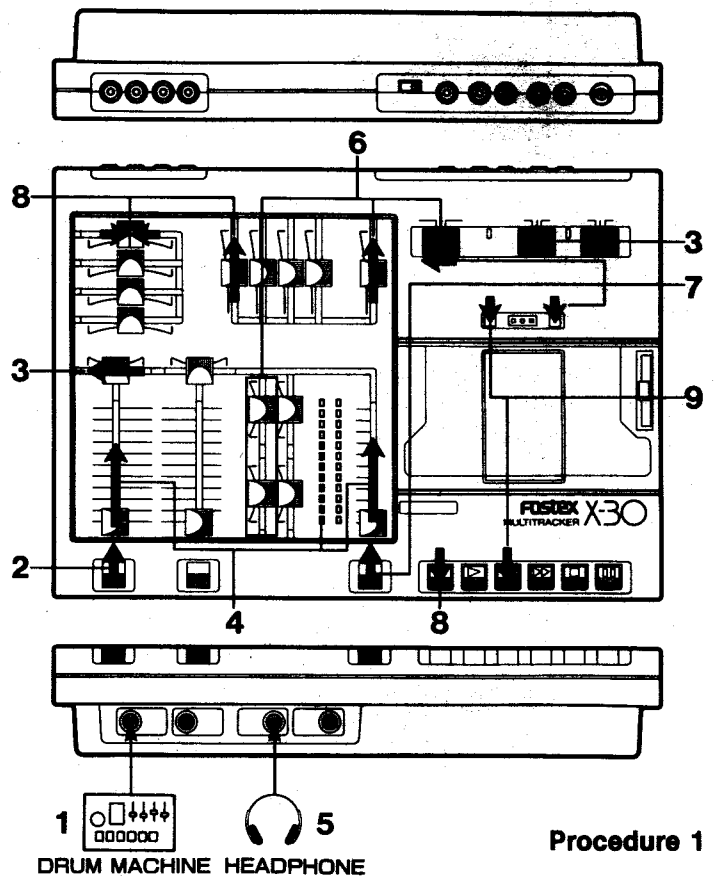

Procedure 1

DRUM MACHINE HEADPHONE

1. For the rehearsal procedure, set the NORM/RMX selector and MONITOR selector to the "Rehearsal at overdubbing" positions shown in the page 8 chart.
2. Plug the electric bass into INPUT jack B.
3. Set the channel B (right side) INPUT selector to MIC and the PAN B control to center.
4. Set the MASTER fader to 7 or 8 and slowly raise the INPUT fader B from its zero position. While checking the meter level, monitor the sound by the headphones and set to a maximum +3~+6. Adjust to your preference.
If the level seems to overshoot too much even though the INPUT fader B is pulled down, set the INPUT selector to LINE and repeat the above step.
5. Press the PLAY button to start the rehearsal. When MONMIX GAIN 1 is raised, the drum machine recorded on track 1 will be heard. Its placement can be adjusted by the MONMIX PAN 1. Set these controls according to your preference. The electric bass sound volume is adjusted by the MASTER fader and its image position by PAN B.
6. After several rehearsals, proceed to the 'take.' Set the REC TRK selector to 2 on the R side to send the electric bass signal to track 2, and slide PAN B to full R.
7. Set the L side REC TRK selector to OFF (center) to prevent the accidental erasure of track 1.
8. Set the NORM/RMX selector and MONITOR selector to positions for "Take at overdubbing" listed in

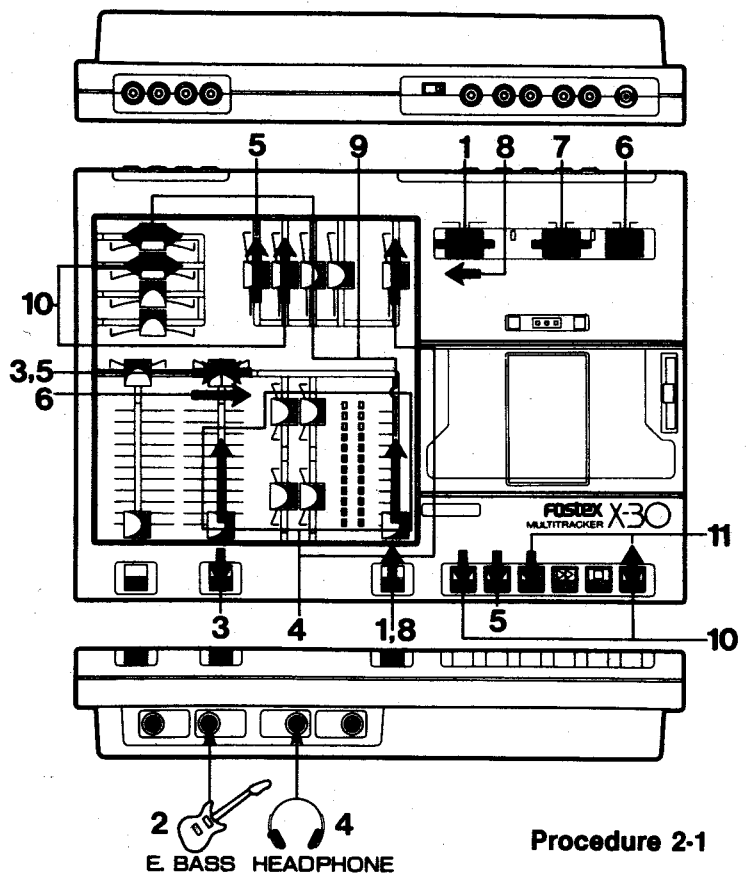

Procedure 2-1

the page 8 chart.

9. Return the MASTER fader setting to 7 or 8, or the same level set in above Step 4.
10. Put the recorder in the REC/PAUSE mode by pressing the PAUSE button, then the RECORD button (REC TRK LED will be dimly lit in red). While in this condition, the electric bass can be monitored by raising MONMIX GAIN 2, and its placement adjusted by MONMIX PAN 2. In the same way as in Procedure 1, the sound volume and placement can be balanced as desired since these adjustments will not affect the recording level.
11. Release the pause mode by pressing the PAUSE button and start the take (REC TRK LED: Will change to bright red). If you hear a mistake, simply rewind to the beginning and begin again.

Procedure 2-2 Overdubbing the electric guitar on track 3

1. Mic the electric guitar here. Place the microphone in front of the guitar amplifier speaker and plug into INPUT jack A.
2. Set the channel A INPUT selector to MIC.
3. Set the NORM/RMX selector and the MONITOR selector to the "Rehearsal at overdubbing" positions. (Refer to the chart in page 8.)
4. Set PAN A at center, MASTER fader at 7 or 8, set the level by the INPUT fader A and adjust EQ while monitoring with the headphones.

5. Press the PLAY button and start the rehearsal. Adjust tracks 1 and 2 sound volume by MONMIX GAIN 1 and 2, and their placements by MONMIX PAN 1 and 2, the same as in Procedure 2-1. Set the electronic guitar sound volume and image position by the MASTER fader and PAN A.
6. After rehearsal, you're ready for the take. In order to send the electric guitar signal to track 3, set the REC TRK selector L side to 3 and slide PAN A to full L. Set R side REC TRK selector to OFF.
7. Set the NORM/RMX selector and MONITOR selector to the positions indicated in the chart "Take at overdubbing." (Refer to page 8.)
8. Return the MASTER fader to 7 or 8.
9. Put the recorder in the REC/PAUSE mode (REC TRK LED will be dimly lit in red) by first pressing the PAUSE button, then the RECORD button, and adjust the electric guitar sound volume and pan position (this will not affect the recording level) by MONMIX GAIN and PAN 3.
10. Press PAUSE again and start the take (REC TRK LED will change to bright red). Rewind the tape upon finishing the recording.

Procedure 2-3 Overdubbing a vocal on track 4

The final overdub is done on track 4. The methods in rehearsal and the take are the same with Procedure 2-1, above, except that the REC TRK selector R side is set to 4.

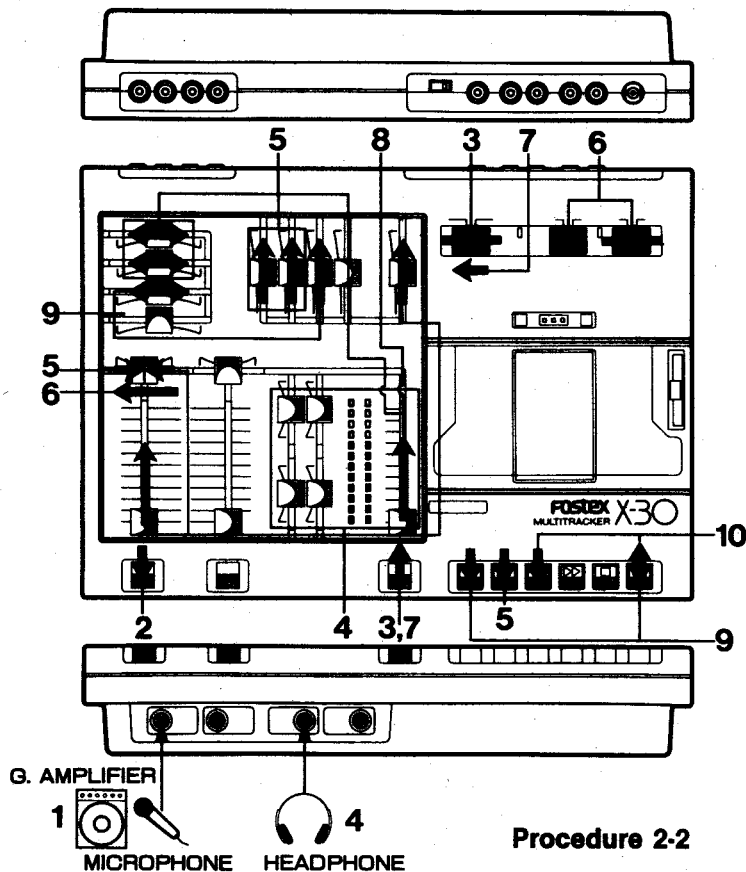

Refer to the operating schematic below to correctly proceed with the operation. You will find that the sequence in which you overdub the various parts is very important. Each tune may require its own particular sequence for best results. Don't be afraid to experiment—you can always do it over.

Procedure 3, Punching-In/Out (Correcting a mistake in a performance)

Rehearsal and take at puch-in/out

"Punching-in/out" is the process of rerecording over a section which contains a mistake. For example, should there be a mistake during the recording of a guitar or synthesizer part near the end of the tune, continue the performance in spite of the mistake. You will fix it later by punching-in/out to create a faultless performance. In practice, the tape is monitored as it is played back and just before the mistake is reached, the recorder is put in the record mode at a silent point, such as at the end of a phrase, and a new part is recorded (punch-in). When the section containing the mistake has been recorded over, return to the playback mode or stop (punch-out) and you will have a perfect recording. The Model X-30 has two modes in "Punch-in/out." One is the "take" mode and the other the "rehearsal" mode.

Take mode : The actual take mode at punch-in/out (Actual recording mode is entered and the performance is replaced.).

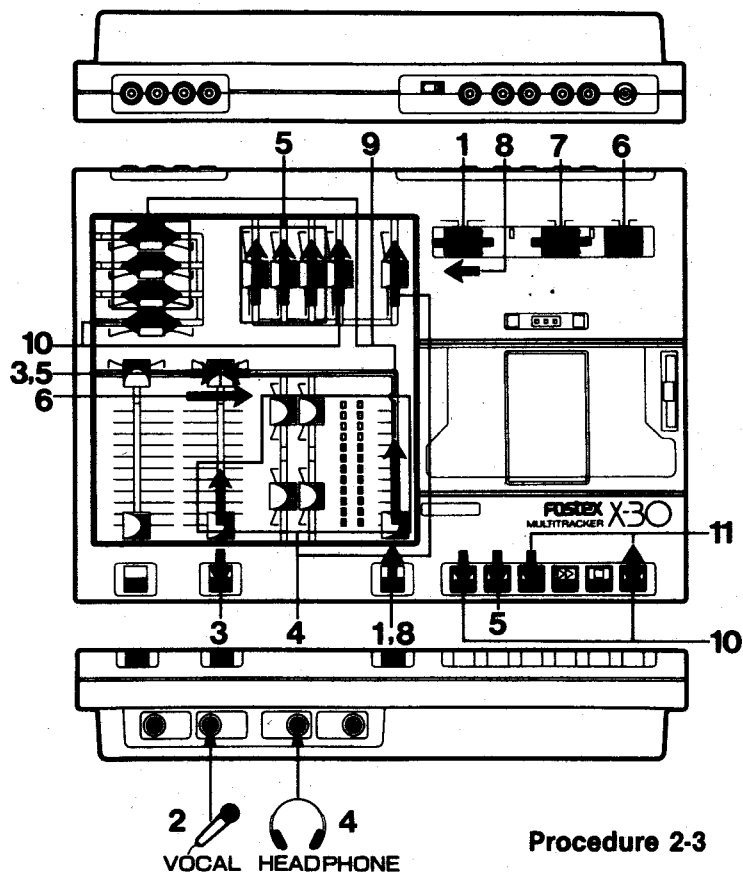

Procedure 2-3

Rehearsal mode : The mode for practicing the timing required at punch-in/out or practicing the performance for inserting prior to the actual take (the monitor sound will punch-in/out but it will not be recorded).

NOTE: Timing is crucial during punch-in/out, so rehearse until you are sure of the timing. If you punch-in too early or punch-out too late, you may have to record the track all over.

1. In the following, the method of replacing a section of the electric guitar sound on track 3 by punch-in/out will be explained.
Since we will start with rehearsal, select the "rehearsal" punch-in/out mode. Refer to RSL/TAKE in the chart on page 6. The rehearsal mode is in effect when the REC TRK LED is lit in green (Fostex 8051 optional foot control is required here.)
2. Plug the microphone, placed in front of the guitar amplifier, to INPUT jack A.
3. Set the channel A INPUT selector to MIC.
4. Set the NORM/RMX selector and the MONITOR selector to the positions for "Take at overdubbing" (Refer to page 8).
5. Select the REC TRK selector L side 3, PAN A to full L and the electric guitar sound will be routed to track 3. The R side of the REC TRK selector, of course, must be set to OFF (center).
6. Set MASTER fader to 7 or 8, slowly raise INPUT fader

A and check the level with the meter. If necessary, monitor the sound with the headphone by changing the MONITOR selector to LINE, alter the sound with EQ, then set the level again with the INPUT fader A. (MONITOR selector must be returned to TAPE.)

7. Adjust all MONMIX GAIN and pan controls 1~4 to a comfortable level. Advance the tape to a point slightly before the mistake, play the tape by pressing the PLAY button and monitor tracks 1~4.
8. Just prior to reaching the mistake, step once on the foot switch, plugged into the PUNCH IN/OUT jack. The REC TRK LED will change from green to amber to indicate the rehearsal mode. In this state, the track 3 playback sound is cut off and in place of it, the electric guitar sound picked up by the microphone plugged into the INPUT jack A will be heard. You can thus practice punch-in timing.
9. After the mistake section has passed, step on the foot switch again. The REC TRK LED will return to green indicating punch-out in the rehearsal mode. You will again hear tape playback on track 3 in the headphones.
10. Repeat steps 7~9 and check to be sure the punch-in/out points are not overlapping with the phrases at both ends, or whether there is any difference in sound volume and tone between the replaced section and sections before or after it. If all is satisfactory, you can now proceed to the take.

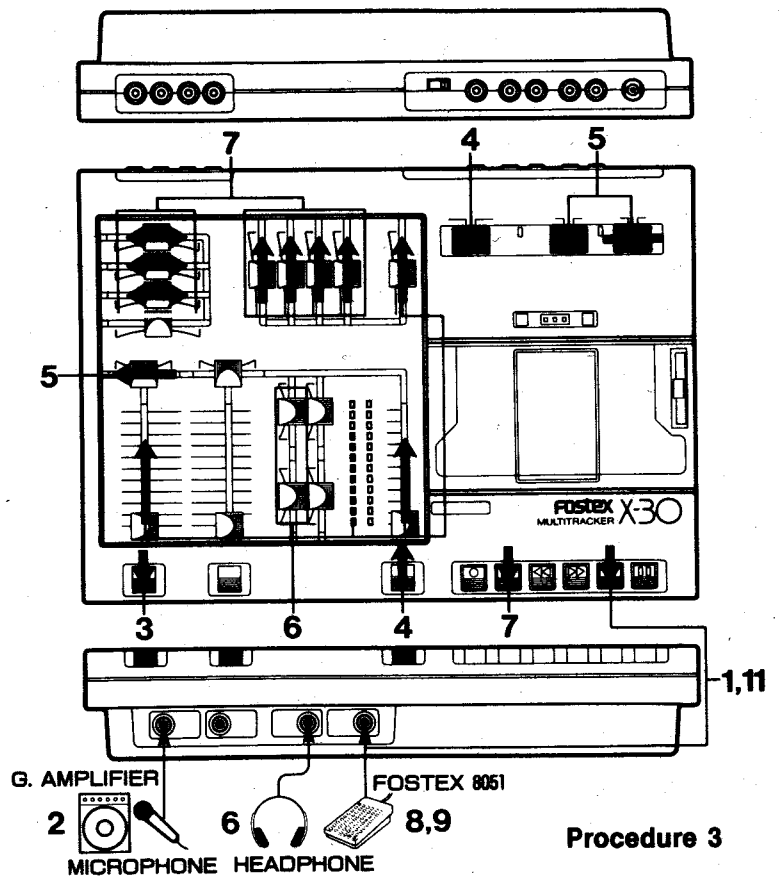

Procedure 3

11. Set the punch-in/out mode to "take" by the STOP button and foot switch. Refer to the RSL/TAKE chart in page 6 for this procedure. It is in the "take" mode when the REC TRK LED is not lit.

12. In this condition, the take will be completed by following the same steps 7~9 carried out for "rehearsal." If you are unsuccessful in replacing the section, repeat the same procedures for punch-in/out. If you feel you have succeeded, replay the section and monitor it to make sure.

(Refer to the following chart on the various changes of the REC TRK LED during the take mode.)

In addition to punch-in/out by the foot switch, you can also use the method (the recorder function and REC TRK selector) shown below. Either method can be used depending on the situation.





















Procedure 4 Mixdown

What is mixdown?

The process of playing and combining of sounds recorded on a multiple number of tracks into 2-track stereo and copying it to the conventional stereo master tape is called mixdown. Mixdown is the final polishing up procedure of a multitrack recording.

1. Connect the LINE OUT jack to the stereo master deck LINE IN jack.
2. Set the NORM/RMX selector and MONITOR selector to the positions for "Mixdown" (Refer to chart in page 8)
3. Set both INPUT faders to zero (to prevent pickup of

Punch in/out method (①~③)

	Initial setting	Play	Punch in	Punch out
① REC TRK selector	OFF 	RECORD 		
② 8051 foot switch	ON 	PLAY 		
③ Recorder function	ON 	PLAY 	RECORD 	STOP 
REC TRK LED	Take mode	①  Dim red	 Bright red	①  Dim red
		②  Light off		②  Light off
REC TRK LED	Rehearsal mode	③  Green	 Amber	③  Green

unwanted noise). Also, set both L and R REC TRK selectors to OFF.

4. Set the MASTER fader to 7 or 8 and press the PLAY button.
5. As you raise the 1 ~ 4 MONMIX GAIN, the sound from these channels will be heard in the headphones. In addition, the placement of each track can be adjusted by the MONMIX PAN knobs. In other words, the sound volume and placement of each track is determined by this control section (The sound monitored by the headphones is that appearing at the LINE OUT jack, and is the signal being sent to the master deck.).
6. You can also separately adjust the L and R channels by the EQ. Output levels of each channel will be indicated by the level meter. Play the tape several times and adjust the sound volume, placement, tone and output level of each channel.
7. Set the master deck in the REC or PAUSE mode to allow checking the recording level and adjust this level so that the meter readings of the X-30 and the master deck are about the same.
8. Begin the mixdown by first setting the master deck in the recording mode and then press the PLAY button.

Note: *Mixing is often a dynamic process. That is, various parts can be emphasized briefly (solos, for example). You will probably record several mixes until you have one you like, so don't be afraid to experiment.*

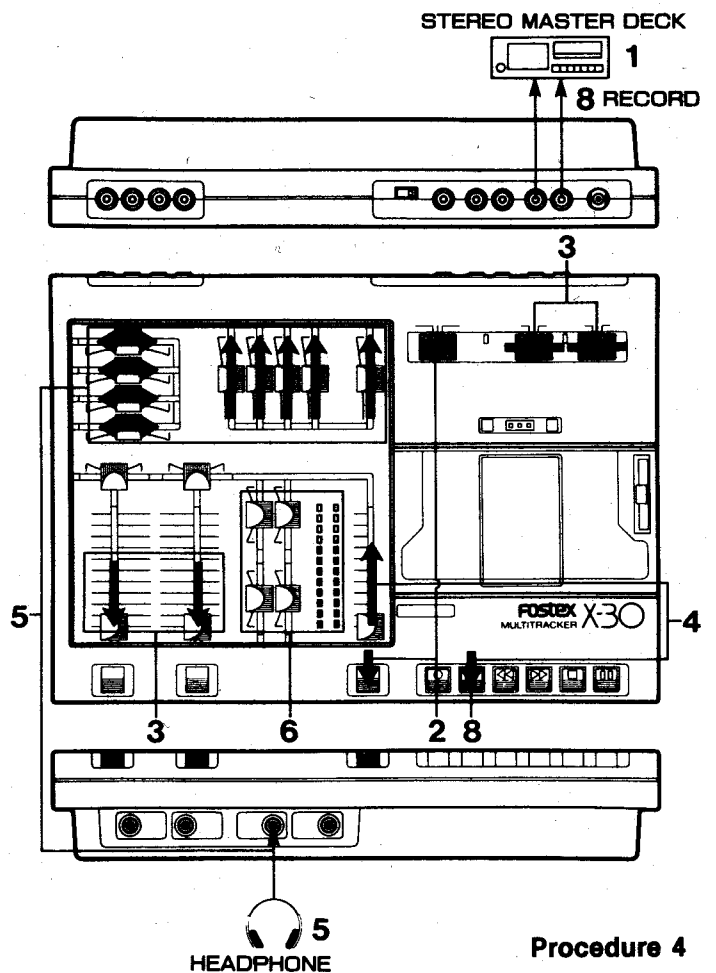

Procedure 4

PING-PONG RECORDING

Ping-pong recording is an indispensable technique when more than four sources are to be recorded.

Please refer to the schematic on this page. Let's assume we have finished recording on tracks 1~3 in Step 1. Now, if another sound (vocal) is recorded on track 4 by the method in the Basic Operation, you will not be able to record any other sound source. Therefore, if you should utilize the remix feature of the X-30 to mix tracks 1~3, you will be able to make a new recording (Step 2). This technique is called "Ping-pong recording." It is literally bouncing sound between tracks of this recorder. Next, tracks 1 and 2 are combined and recorded onto track 3 (Step 3); record new sounds on tracks 1 and 2, and you will have recorded 7 sources.

Additionally, the X-30 can mix a maximum of two inputs in parallel with the ping-pong recording. We shall call this "Plus one (or two)" recording (Steps 4~6). In other words, as you make a ping-pong recording, you can record an extra two sources using the overdubbing

method to be able to ping-pong the recording.

NOTE: While ping-pong recording is very useful, each time you bounce tracks you lose one generation of fidelity. Even with noise reduction, hiss becomes a major problem after two "bounces" or generations. For best results, don't ping-pong tracks more than twice.

Check points in ping-pong recording will be listed in the following for your reference.

- Be extremely careful in setting the sound balance between individual tracks as they cannot be changed after they are combined.
- Due to the peculiar nature of tape recorders, the tone controls should be adjusted to compensate for signal deterioration (Normally, a slight boost of the high region and a slight cut of the lower region.).

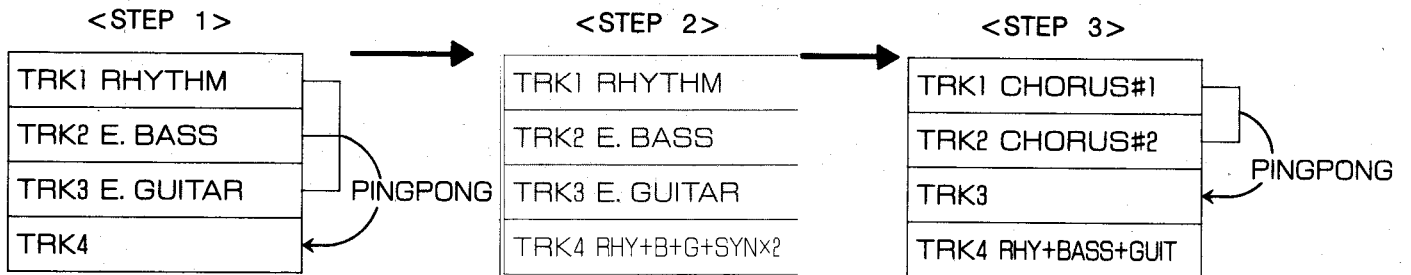

Procedures in ping-pong recording

We shall now proceed to the actual procedures in ping-pong recording. The explanations will be in the example below.

Example

Two synthesizers will be "Plus two" recorded onto tracks 1-3 recorded in the Basic Operation Section and ping-pong recorded onto track 4 (Refer to the track schematic, page 24.).

Process

Set up by referring to the schematic, Page 25.

1. After checking that all sound volume controls are set to 0 and that the REC TRK selector is OFF, set the NORM/RMX selector to RMX.
2. Set the MONITOR selector to LINE.
3. Plug the synthesizers for "Plus two" to INPUT jacks A and B.

4. Set the INPUT selector to LINE.
5. Select the R side REC TRK selector to 4.
6. Slide the INPUT PAN A and B, and also the MONMIX PAN 1-3, to full R. This completes setting of the selectors and pan pots, and we shall now do balancing and level setting.
7. Set the MASTER fader to 7 or 8.
8. Slowly raise INPUT faders A and B and set the level by watching the meter (The R meter only should be indicating.).
9. Press the PLAY button.
10. Raise MONMIX GAIN 1-3 and balance the levels of each track.
11. If necessary, adjust the tone by the R channel EQ (note that tone of the "plus two" synthesizers will also change).
12. Practice performing several times and when the proper levels are determined, go to the "take" by pressing the RECORD button. Although the sound



can be monitored by the headphones or by LINE OUT (with an amplifier plugged into the LINE OUT jack), the R channel only will be heard.

13. To monitor the recorder, raise MONMIX GAIN 4 only, set the image position by PAN and use the headphones (set MONITOR selector to TAPE and adjust the PHONES level pot) or the LINE (Leave the NORM/RMX selector at RMX.).

Refer to the above procedures at ping-pong recording under other methods but be sure to check the following in addition to the above.

- A) Set to the remix mode, (by setting NORM/RMX Selector to RMX).
- B) Balance the track, in which the sound for ping-pong is recorded, by MONMIX.
- C) Set PAN and MONMIX PAN to L when recording on odd numbered tracks (1, 3) and R for even numbered and tracks (2, 4).

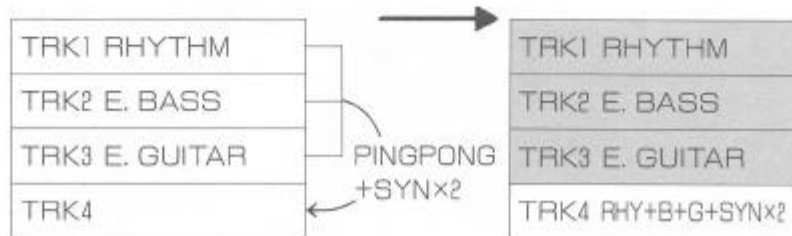

SECTION 6 RECORDING PROCEDURES (SPECIAL TECHNIQUES)

You will have understood the basic methods in multitrack recording by explanations in the previous section. In this section, further techniques will be explained.

1. Simultaneous recording of multiple sources using a submixer.

The Model X-30 features a two input mixer, but occasionally you will want to record three or more sound sources in one pass.

In this case, it will be very convenient if a stereo output submixer is used.

Example

A stereo recording is to be made on tracks 1 and 2, using an 8 IN 2 OUT keyboard mixer.

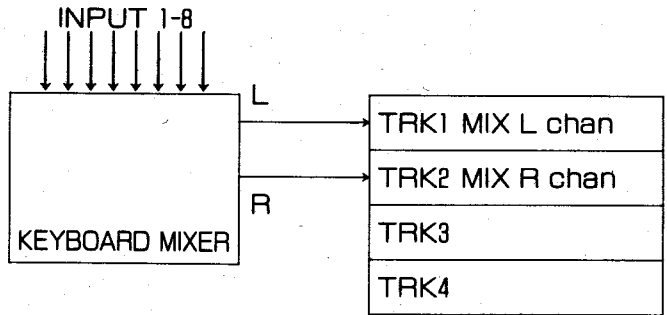
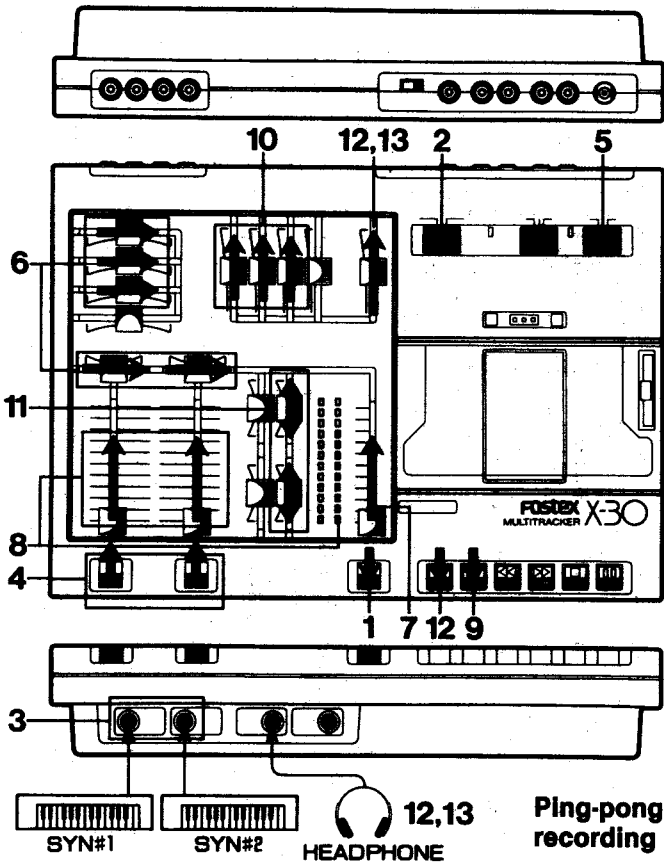

Process

Set the various controls by referring to the schematic, page 26.

1. Connect the keyboard mixer L and R outputs, respectively, to INPUT jacks A and B (Connecting to BUSS IN is better if EQ of this Unit is not to be used.).
2. Set the NORM/RMX selector to NORM, both channels of the LINE/MIC selector to LINE.
3. Set the PAN controls for the L and R channels, respectively, to full L and R.
4. Set the INPUT faders for both reset channels to the same scale setting.
5. Raise the MASTER fader to a suitable level while referring to the meter.
6. Select 1 and 2 of the REC TRK selector.
7. As tape monitoring will be by MONMIX, set the MONMIX PAN 1 to L, and 2 to R, and adjust both 1 and 2 of the MONMIX GAIN to the same level. MONMIX can be monitored by the headphone if the MONITOR selector is set to TAPE. Set the NORM/RMX selector to RMX if you wish to monitor the LINE OUT signal.
8. Start recording by pressing the RECORD button.

2. Tape sync

The simplest approach is a recorded clock pulse (which is not the same as a MIDI clock). Some drum machines, and synths generate a digital type square wave pulse. This type of data is difficult for any recorder to record accurately. The leading edge of the wave gets slightly

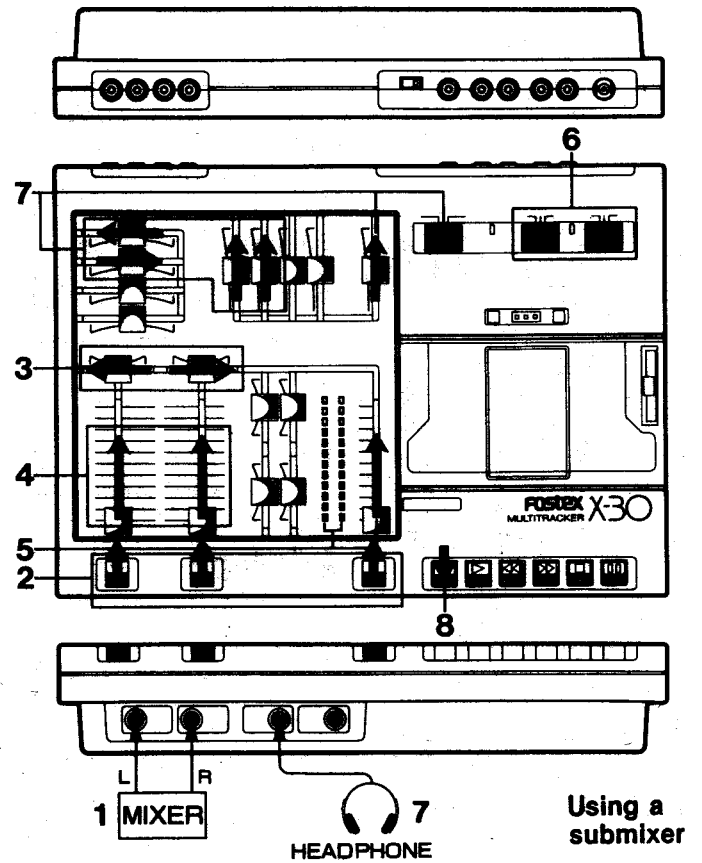

rounded so that when the signal goes back into the drum machine (etc.), it doesn't recognize the (now sloped) pulse, so it loses beat. To eliminate this problem, many machines use what is called FSK (Frequency Shift Keying). FSK converts the digital clock inside the drum machine (etc.) into one of two sinewave frequencies (1kHz or 2kHz) which is significantly easier for the recorder to handle. This is not a quirk of the X-30, it is true for all tape recorders. If you have a drum machine (etc.) that puts out a digital clock pulse you'll probably need a unit like the Fostex TS-15 which directly converts a digital pulse to FSK, and (on playback) back again.

There are sequencers and rhythm machines which do not have tape sync out. It is then necessary to use a tape sync (FSK) unit such as the Fostex Model TS-15. When this tape sync technique is used, the four tracks of the X-30 can be utilized more effectively as it will then be possible to create depth by adding several layers of a tone from a single synthesizer or swap one rhythm machine with another one.

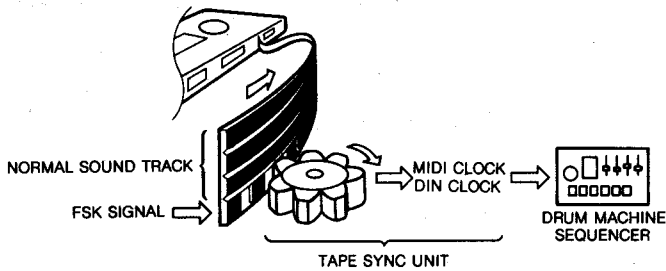

System layout

A representative layout diagram of a tape sync recording system is presented below.

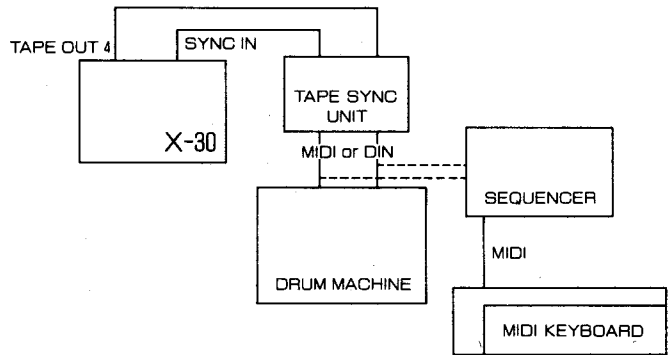

Procedure 1 Recording the sync signal

When a recording is to be made by tape sync, a tape sync signal such as the FSK signal must be recorded first.

Example

The FSK signal from a rhythm machine having the tape sync facility is connected to the SYNC IN jack of the X-30 and recorded on track 4 and the basic rhythm which will be the musicians guide, is recorded on track 1 at the same time.

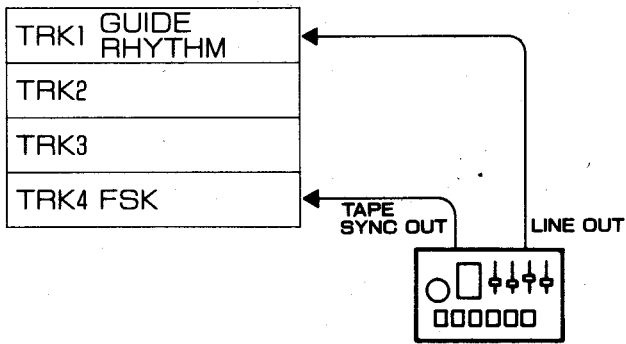

Process

Set the various controls by referring to the right schematic on this page.

1. Plug the rhythm machine tape sync output to the SYNC IN jack of the X-30 and the audio output to the INPUT jack A.
2. Set the NORM/RMX selector to NORM.
3. Set the PAN A to full L.
4. Set the INPUT fader A and MASTER fader to a suitable level, and adjust the guide rhythm recording level. As the SYNC IN level is fixed, normally it need not be adjusted.
5. Select 1 and 4 of the REC TRK selector.
6. Monitor the recording with the headphone by setting the MONITOR selector to TAPE and adjusting the GAIN and PAN of MONMIX. The track 4 FSK signal cannot be monitored at LINE OUT during the record

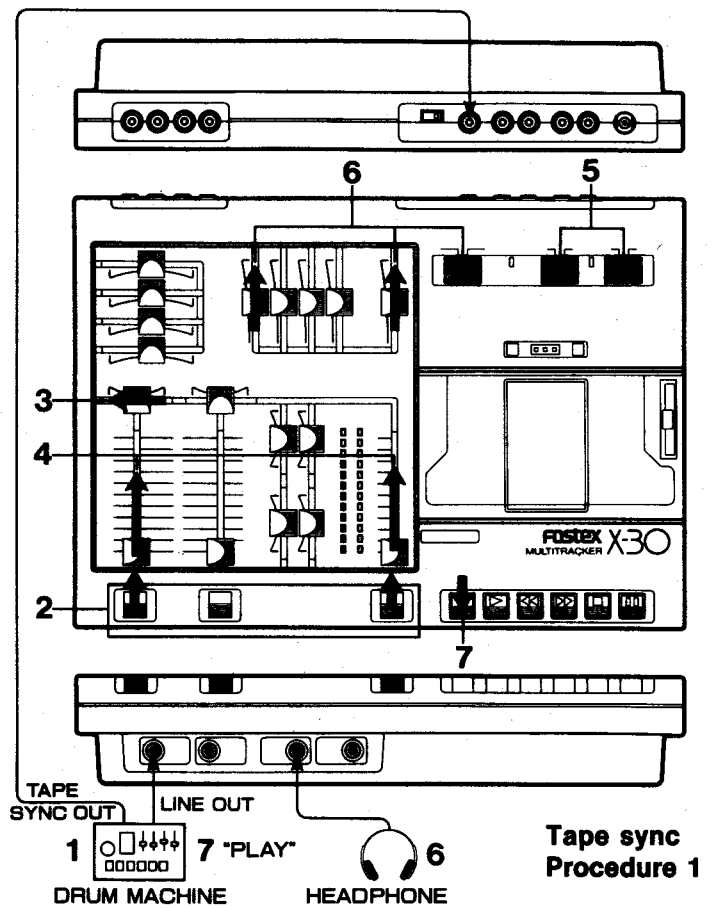

mode.

7. Start recording by pressing the RECORD button. Allow the tape to run (record) for about 5 to 10 seconds, then start the rhythm machine (this is to record the continuous pilot signal).

Procedure 2 FSK signal playback and sync mode test

In the following, the FSK signal recorded in Procedure 1 is reproduced, to check whether the sync signal is correct or not. As the sync signal could be disturbed depending on the condition of the tape and recording level of the sync signal, always check it.

Example

The FSK signal recorded in Procedure 1 is be fed to the rhythm machine, let it sync with the X-30, compare it with track 1 to check whether it is in sync or not.

Process

Set the various controls by referring to the schematic on this page.

1. Connect the track 4 TAPE OUT to the SYNC IN jack of the rhythm machine.
2. Set the NORM/RMX selector to NORM and the MONITOR selector to MIX.
3. Set the INPUT selector A to LINE, PAN A to the center position, and raise the INPUT fader A and MASTER fader to a suitable level by referring to the meter.
4. Set the rhythm machine in the external sync mode (refer to its manual for the method), rewind tape to

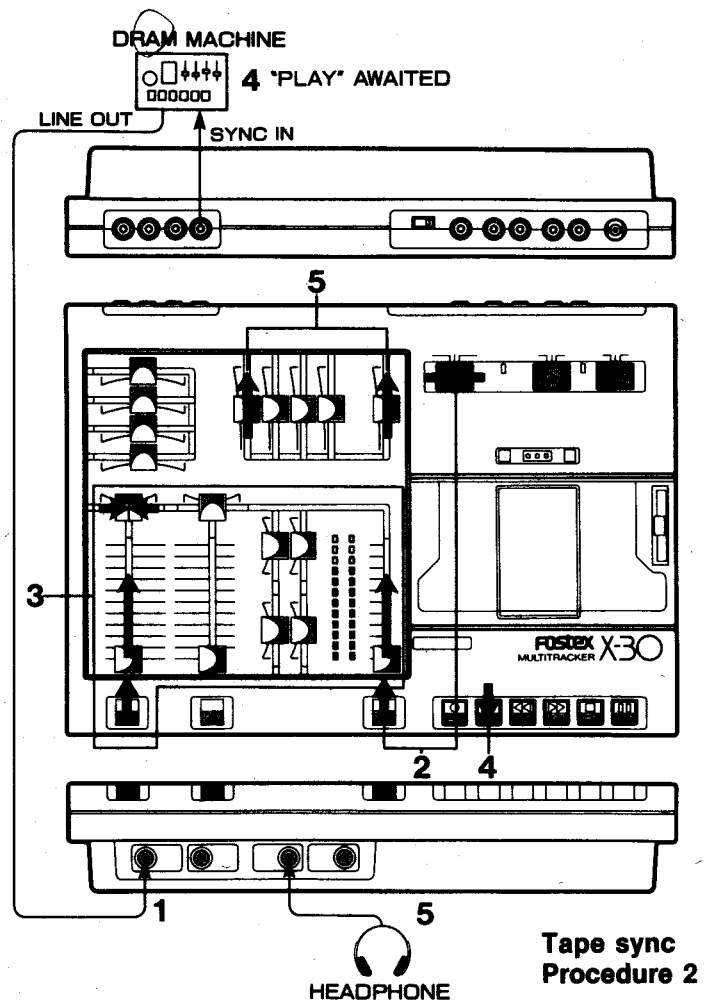

Tape sync Procedure 2

the pilot tone recording, and after setting it in the PLAY mode, put the rhythm machine in the "standby" mode (by pressing PLAY, etc.).

- As the rhythm machine will start performing in sync from the start of the FSK signal if everything is correct, check whether the performance of INPUT A is in sync with track 1 (raise GAIN of MONMIX 1).

If sync should slip during some point of the performance, repeat Procedure 1 again by changing the FSK signal recording level (change the drum machine sync output level if possible or, if it is fixed, use the regular INPUT (not SYNC IN) of this Unit) or changing the tape to a fresh one.

Procedure 3 Overdubbing by reference to the guide rhythm

After confirming in Procedure 2 that sync is normal, we shall overdub by following the track 1 guide rhythm.

Example

Overdubbing of the base on track 2 and the rhythm guitar on track 3, will be made by following the guide rhythm on track 1. Then, the lead guitar will be overdubbed (refer

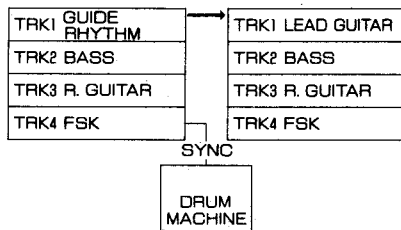

to track diagram) while synchronizing the rhythm machine and erasing the track 1 guide rhythm at the same time.

Process

Set the various controls by referring to the diagram, page 31.

Refer to the Basic Operation Section for overdubbing on tracks 2 and 3 (page 14). In the following example the procedure of recording the lead guitar only onto track 1 in sync with the rhythm machine will be explained.

- Connect the rhythm machine to INPUT jack A and the lead guitar to B and set the INPUT selector A to LINE, B to MIC or LINE (according to the output level of guitar. Either jack can be used).
- As the lead guitar plugged into B will be recorded on track 1, PAN B is slid to full L and the rhythm machine at A is slid to full R.
- Set the NORM/RMX selector to NORM.
- Set the MONITOR selector to MIX.
- Set the REC TRK Selector L to 1.
- Set the levels with the INPUT fader and MASTER fader by referring to the meter.
- The monitor balance is adjusted by MONMIX GAIN and PAN (the rhythm machine is fixed to R by PAN)
- In the same way as in Procedure 2, after rewinding the tape to the pilot tone recording, press the PLAY button for the rehearsal mode, or the RECORD button for the take, and put the rhythm machine in standby.

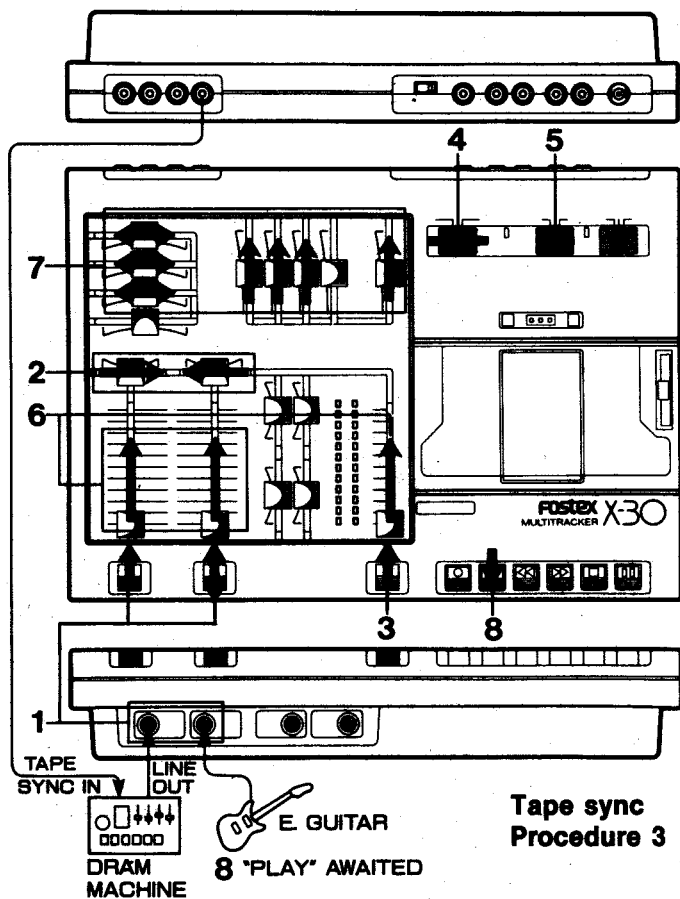

As the rhythm machine will start playing when the FSK signal arrives at the starting point of the performance, record the lead guitar in sync with it.

If you should make a mistake and must record all over again, you should start again from the beginning as it is difficult to sync the rhythm machine from an intermediate point in the tune when recording by this procedure.

Procedure 4 Mixdown with sync playback

The finishing touch in sync recording is mixdown. As it is possible to mix the sync performance of the rhythm machine and sequencer by the tape sync signal in addition to the tape sound in this process, it will lead to producing a high quality, truly sophisticated recording.

Example:

Mixdown with the rhythm machine in sync with the tape completed in Procedures 1~3.

Process:

Set the various controls by referring to the schematic.

1. Feed the rhythm machine stereo out L and R, respectively, to the X-30 INPUT jacks A and B, connect TAPE OUT 4 to the rhythm machine SYNC IN and the LINE OUT to the input of the deck used for the mixdown.
2. Set the NORM/RMX selector to RMX and the INPUT selector to LINE.
3. Slide PAN A and B, respectively, to full L and R.

4. Raise the MASTER fader to 7~8. (with this arrangement, the rhythm machine sound to the INPUT fader and 1~3 of MONMIX are all routed to the MASTER fader.)
5. Push the PLAY button of the X-30, and set the DRUM MACHINE in stand by before recorded play starts.
6. When the sync performance starts, adjust the volume of drum machine by INPUT fader, set the panning and balance of each 1~3 track by MONMIX GAIN and PAN. (Be sure to fully retard track 4, MONMIX GAIN)
7. If necessary, set the tone of each channel A and B by EQ.
8. Practice several times. When you are satisfied with the balance, begin the mixdown to the master recorder.

Refer to the Basic Operation Section for details on the mixdown procedure (page 20).

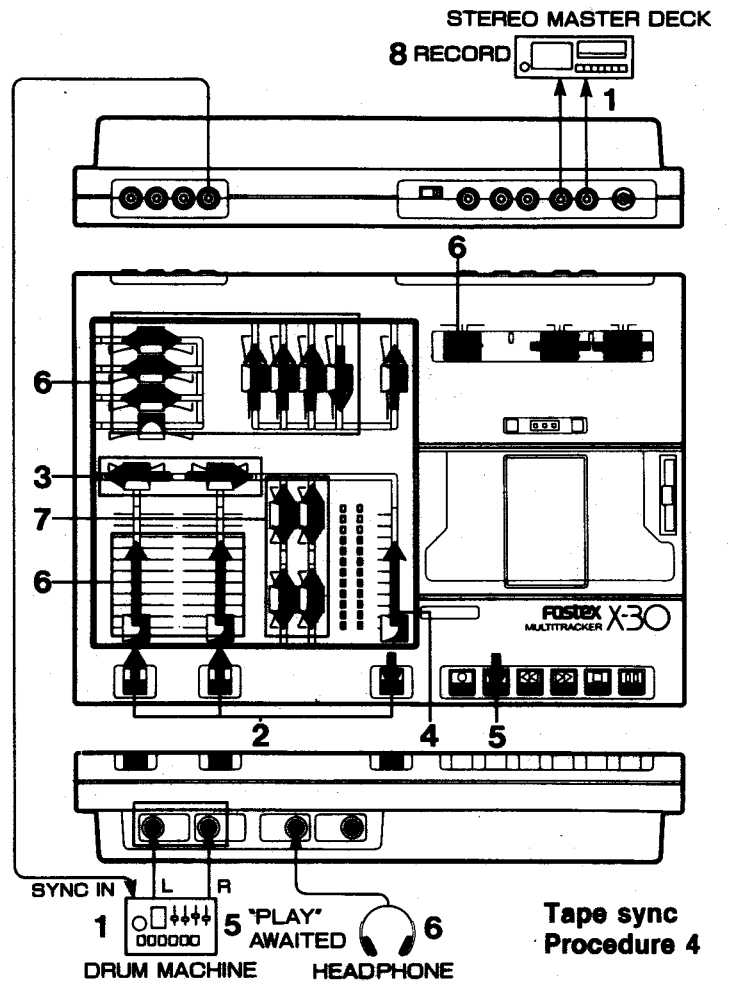

3. Mixdown including signal processing

One of the joys in mixdown is creating your own sound using signal processors to the best of your skill. Various processors can be used in the X-30 by connecting them to the TAPE OUT jack and the BUSS IN jack.

Example

Reverb will be applied to the vocal on track 4 and delay to the track 3 guitar at mixdown in the Basic Operation Section (page 20).

Process

Set the various controls by referring to the schematic.

1. TAPE OUT jack 4 is connected to the reverb unit INPUT, and the reverb output to the BUSS IN jack.
 2. TAPE OUT jack 3 is connected to the delay unit INPUT, and the delay OUTPUT to the INPUT jack A or B, (PAN A or B) is set to a suitable position.
- Then, by returning the effect output only of both processors, it will result in adding the effect to the output from the LINE OUT jack.

Refer to the item on mixdown in the Basic Operation Section for detailed methods on mixdown (page 20).

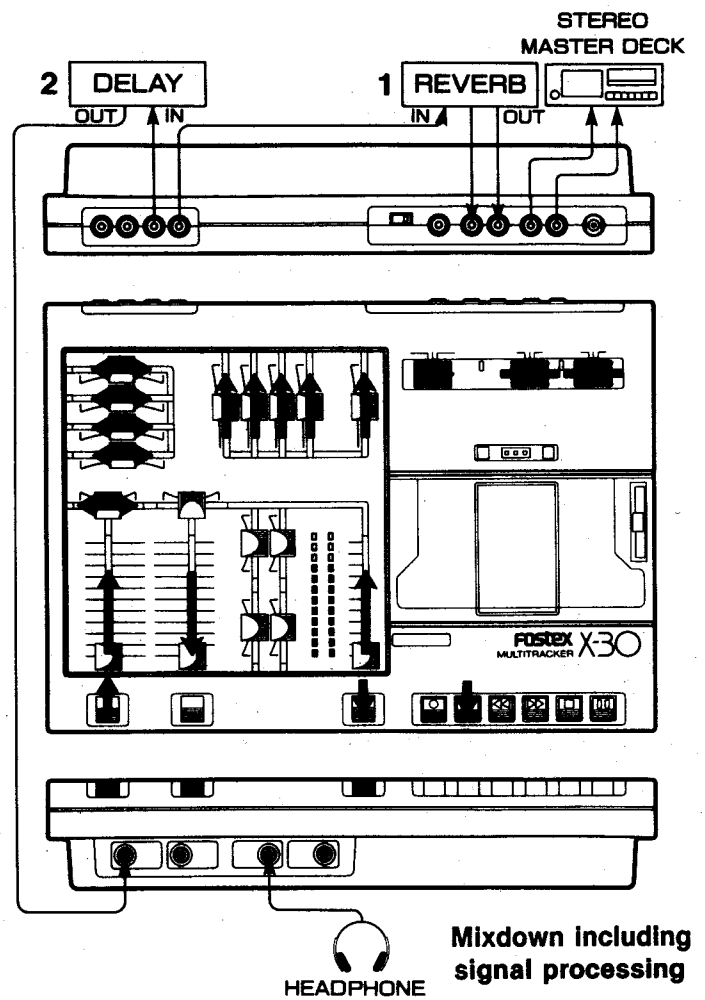

SECTION 7

TROUBLE SHOOTING

1. Sound quality

Phenomenon	Check point	Countermeasure
Wow flutter and drop out	Is the capstan and pinch-roller clean?	Clean both capstan and pinch roller
	Check tape for any damage	Replace with a new good quality tape
Sound is greatly different from the original recording	Is the head clean?	clean the head
	Are you using a tape other than the chrome type?	Use the chrome tape (CrO ₂ , Type II)
	Are switches for Dolby type (B or C) and ON/OFF correctly set?	Set the Dolby NR selector identical to that used for recording
Sound is distorted	Is the INPUT selector ② set properly?	Set selector to position for optimum level

2. At recording

Phenomenon	Check point	Countermeasure
Sound cannot be sent to the desired track	Is recording track and PAN ④ in their correct relation?	Note that L is for tracks 1 and 3 and R is for tracks 2 and 4
A wrong track sound is heard	Are you sure NORM/RMX selector ③ is not set at RMX?	Set to NORM other than for ping pong recording and at mixdown
Tape playback sound pitch is different from that at recording	Is the PITCH control ⑩ setting the same as at recording?	If different, adjust with the PITCH control ⑩
Cannot record	Is the cassette record protect tab broken off?	Block the tab hole with scotch tape

3. Tape transport system

Phenomenon	Check point	Countermeasure
Tape is not transported	Is the cassette correctly loaded?	Reload cassette so that the clip on front side securely holds the cassette
	Is the PAUSE button ⑪ pressed?	Release the PAUSE button ⑪



4. Control panel

Phenomenon	Check point	Countermeasure
Cannot monitor tape with headphones	Is the MONITOR selector ⑫ set to LINE?	Set MONITOR selector ⑫ to MIX or TAPE
No sound from tape when MON MIX GAIN ⑬ is raised during mixdown and ping pong recording	Is the MASTER fader ⑭ raised to a suitable level?	Raise the MASTER fader ⑭ to a suitable level

5. Others

Phenomenon	Check point	Countermeasure
No power to the unit	Is the AC adaptor cable correctly plugged into the X-30 Unit?	Check and correctly plug the cable into the X-30 power receptacle

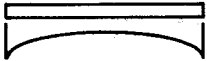
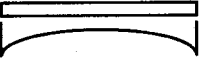
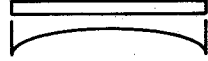
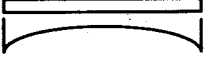
TRACK CHART

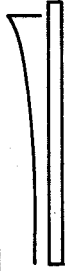
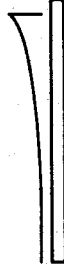
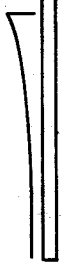
X-30 TRACK CHART						NO.	
TITLE: _____			COMPOSED BY: _____				
DOLBY: OFF / B / C		TAKE: _____		DATE: / /		TIME: _____	
1		2		3		4	
PAN 		PAN 		PAN 		PAN 	
NOTE	GAIN 	NOTE	GAIN 	NOTE	GAIN 	NOTE	GAIN 

SECTION 8

X-30 SPECIFICATIONS

INPUT (X2)	- 50dBV (3mV) / - 10dB (0.3V) switchable 20k Ω , unbalanced	WOW AND FLUTTER	$\pm 0.1\%$ peak, weighted (IEC/ANSI)
BUSS IN (X2)	- 10dBV (0.3V), 20k Ω	RECORDING TIME	30min. for C-60
SYNC IN	- 10dBV (0.3V), 20k Ω	FREQUENCY RESPONSE	Mixer section: 20Hz ~ 20kHz ± 2 dB Recorder section: 40Hz ~ 12.5kHz ± 3 dB
LINE OUT (X2)	- 10dBV (0.3V) 10k Ω or higher, unbalanced	SIGNAL TO NOISE RATIO OVERALL	70dB or more, weighted
TAPE OUT (X4)	- 10dBV (0.3V) 10k Ω or higher, unbalanced	CHANNEL SEPARATION	50dB or more (at 1kHz)
HEADPHONE OUT	100mW (max.) 8 ~ 40 Ω	DIMENSION	327 (W) x 64 (H) x 227 (D) mm
EQUALIZER	± 15 dB (at 150Hz/10kHz) Shelving type	WEIGHT	2.3kg
RECORDING TAPE	Compact cassette C-60/C-90 IEC TYPE II for use at high bias position (TDK-SA, MAXELL-XL-II)	POWER REQUIREMENT	DC 12V (11-15V) 4.8W FOSTEX AD-12 AC adaptor 120VAC, 60Hz. 220/240VAC, 50Hz
RECORD TRACK	4 track one direction		
RECORD/PLAYBACK CHANNEL	4 channels. Records up to 2 channels at time		
NOISE REDUCTION	Dolby B/C (OFF/B/C switchable)		
TAPE SPEED	4.8 cm/s (1-7/8ips)		
PITCH CONTROL	$\pm 15\%$		

specifications subject to change without notice.

*Dolby noise reduction manufactured under license from Dolby Laboratories Licensing Corporation. "Dolby" and the double-D symbol are trademarks of Dolby Laboratories Licensing Corporation.

SECTION 9

BLOCK DIAGRAM

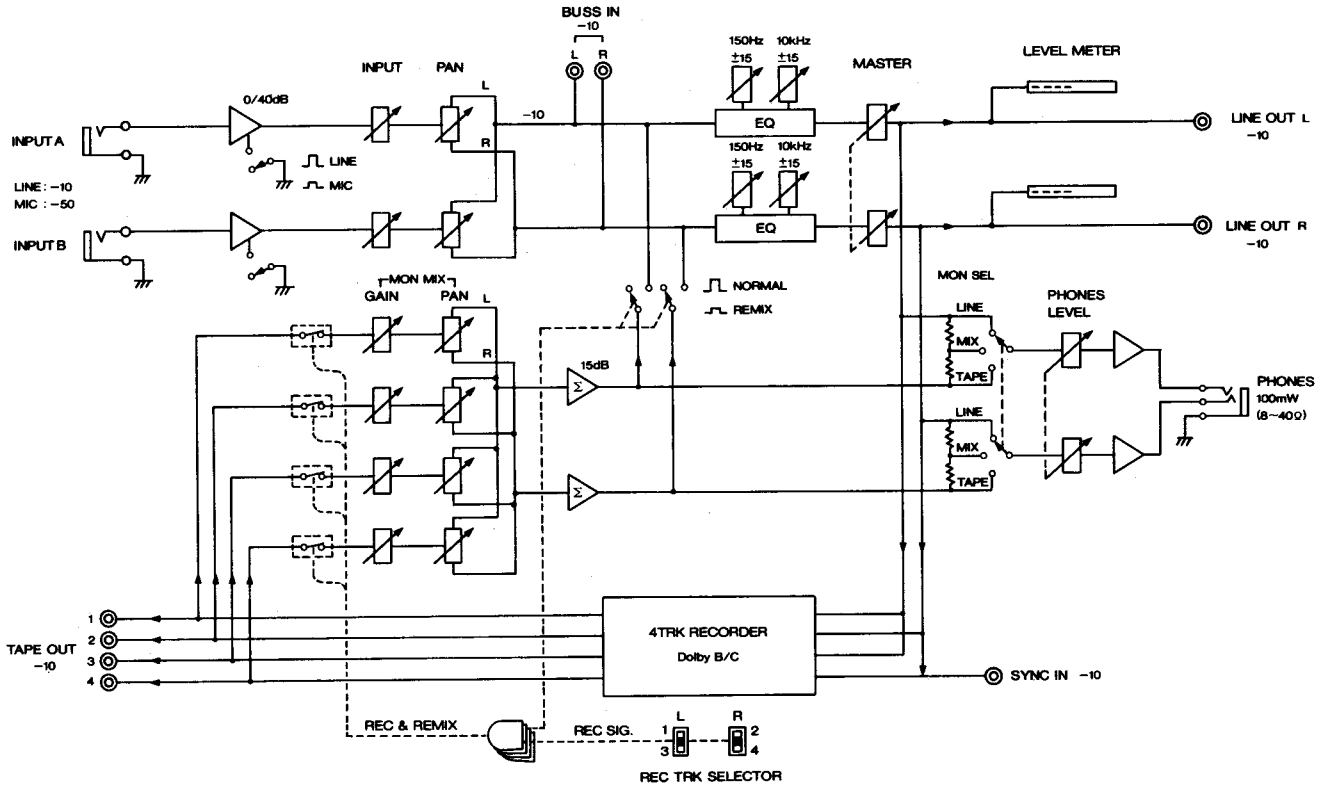

Fostex

FOSTEX CORPORATION 560-3, Miyazawa-cho, Akishima, Tokyo, Japan **FOSTEX CORPORATION OF AMERICA** 15431, Blackburn Ave., Norwalk, CA 90650, U.S.A.

©PRINTED IN JAPAN April 1987 8288 1710 00