

Liebert® XDCF™

User Manual—10kW / 2.8 Tons / 34,000 BTUh



IMPORTANT SAFETY GUIDELINES

SAVE THESE INSTRUCTIONS



CAUTION

Risk of piping and component rupture. May cause injury or equipment damage.

Closing service valves may isolate liquid refrigerant, causing high pressure and rupture of piping. Do not close valves without follow recommended procedures for repair, maintenance and replacement of components. Installing pressure relief valves in field piping that may become isolated by service valves.

Fluorinated Greenhouse Gas Requirements—European Union

Stationary air conditioning, refrigeration, heat pump equipments and stationary fire protection systems in the European Community market and operating with fluorinated greenhouse gases (f-gas), such as R407C, R134a, R410A, must comply with the F-Gas Regulation: (EC) No. 842/2006 (F-gas). The regulation prohibits, among other actions, venting fluorinated greenhouse gases to the atmosphere.

The F-Gas Regulation also requires operators to use use all measures that are technically feasible and do not entail disproportionate cost to prevent leakage of these gases, to test for leakage regularly and to recover f-gas during equipment service and maintenance and before disposing of equipment.

Refer to the full regulation for additional details.

TABLE OF CONTENTS

IMPORTANT SAFETY GUIDELINES	INSIDE FRONT COVER
1.0 LIEBERT XDCF COMPONENT LOCATIONS AND MODEL NUMBER NOMENCLATURE	1
2.0 GENERAL PRODUCT INFORMATION	3
2.1 References	3
2.2 Parts Included With Liebert XDCF	3
2.3 Room Preparation	3
2.4 Product/System Description	4
2.5 Equipment Inspection	4
2.5.1 Unit Handling	4
2.6 Unpacking the Liebert XDCF	5
2.6.1 Recyclable Packaging	5
3.0 MECHANICAL CONSIDERATIONS	6
4.0 INSTALLATION	7
4.1 References	7
4.2 Installation Considerations	7
4.3 Mounting Lower Liebert XDCF Module	8
4.3.1 Preparing the Lower Module for Attachment	8
4.3.2 Attaching Lower Liebert XDCF Module	9
4.4 Attaching Upper Liebert XDCF Module	11
4.4.1 Preparing the Upper Module for Attachment	11
4.4.2 Attaching Upper Liebert XDCF Module	12
5.0 PIPING CONNECTIONS AND PIPING ACCESS POINTS	13
5.1 European Union Fluorinated Greenhouse Gas Requirements	13
5.2 Connection Methods and Points	13
5.2.1 Header System	13
5.3 Recommended Piping Size	14
5.4 Connecting Liebert XD Flex Pipes to Liebert XDCF Modules	14
5.5 Connecting a Liebert XDCF with Liebert XD Flex Pipe to an Operational Liebert XD System	14
5.6 Disconnecting a Liebert XDCF With Liebert XD Flex Pipe From a Liebert XD System . . .	16
5.7 Insulation	17
6.0 CHECKLIST FOR PROPER INSTALLATION	18
7.0 MAINTENANCE	19
7.1 Fluorinated Greenhouse Gas Requirements	19
8.0 SPECIFICATIONS	20

FIGURES

Figure 1	Liebert XDCF component locations	1
Figure 2	Model number nomenclature	2
Figure 3	Liebert XDCF hydraulic diagram	4
Figure 4	Unpacking the Liebert XDCF.	5
Figure 5	Overall dimensions	6
Figure 6	Liebert XDCF unit mounting locations	7
Figure 7	Lower Liebert XDCF attachments.	8
Figure 8	Locator hole for lower unit stud	9
Figure 9	Liebert XD Flex Pipe support panel attachment	10
Figure 10	Upper Liebert XDCF attachment.	11
Figure 11	Attaching Liebert XD Flex Pipe retainers.	12
Figure 12	Liebert XDCF supply and return piping access points.	13
Figure 13	Liebert XD prefabricated piping assembly	15
Figure 14	Detail view of Liebert XD Flex Pipe and prefabricated piping port.	15
Figure 15	Liebert XD system with prefabricated piping assembly and Liebert XD Flex Pipe	16
Figure 16	Profile view of the Liebert XD system	17
Figure 17	Piping mains without Liebert XDCF and Liebert XD Flex Pipe	17

TABLES

Table 1	Branch piping sizes for refrigerant loop	14
Table 2	Liebert XDCF specifications.	20

1.0 LIEBERT XDCF COMPONENT LOCATIONS AND MODEL NUMBER NOMENCLATURE

Figure 1 Liebert XDCF component locations

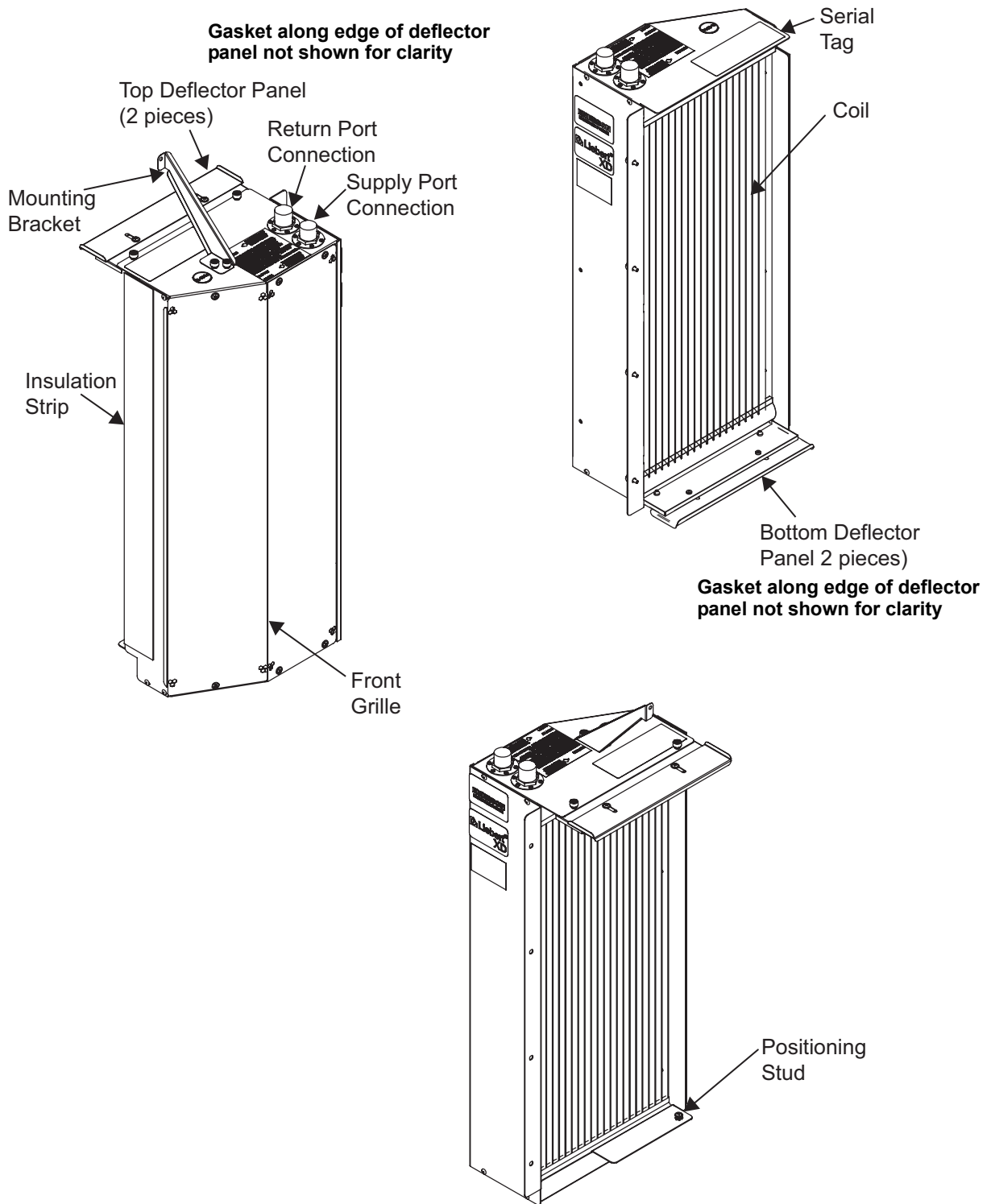
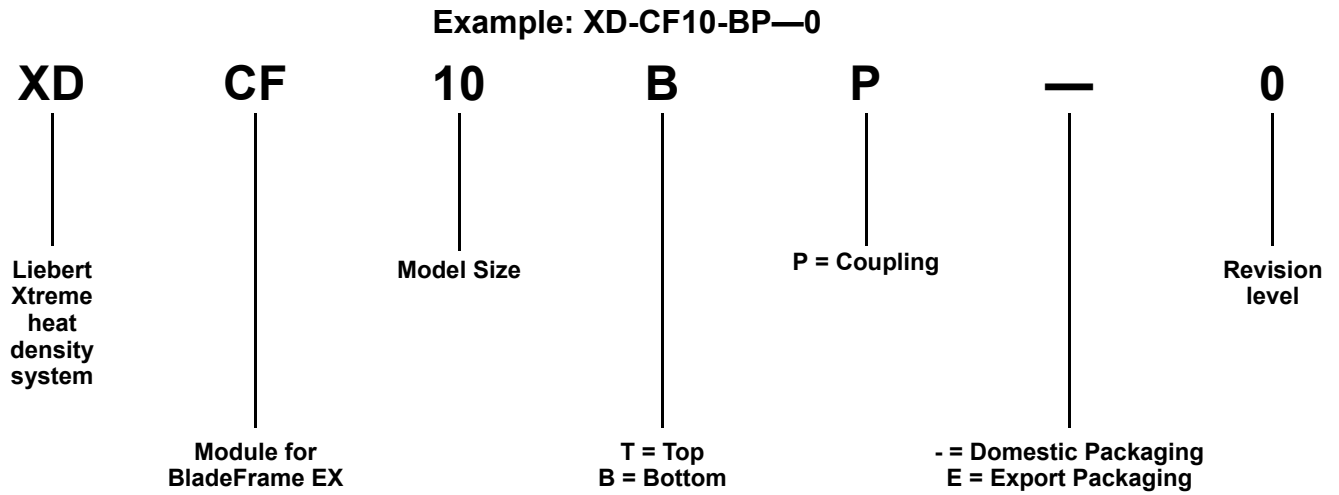

Figure 2 Model number nomenclature



2.0 GENERAL PRODUCT INFORMATION

The Liebert XDCF™ is a self-contained module designed to cool Egenera's BladeFrame EX cabinets and equipment without exhausting heat into the room.

Liebert XDCF modules consist of a sheet-metal frame, coil and filter dryer. It has no moving parts and needs no electricity.

The Liebert XDCF system consists of:

- Liebert XDCF modules—upper and lower models are available
- Liebert XD Flex Pipe (optional)—connects Liebert XDCF units to supply and return piping (ships with Liebert XDCF)
- Liebert XD Piping—delivers R-134a refrigerant through flexible piping
- Liebert XDP or Liebert XDC—supplies R-134a refrigerant to Liebert XDCF modules (see Liebert XDP or Liebert XDC user manual for required chiller or drycooler)

Liebert XDCF modules attach to the rear of the Egenera BladeFrame EX™ cabinet. Heated air from the BladeFrame cabinet is exhausted through the Liebert XDCF, which absorbs the heat. The cooled air passes into the room and the heat is carried away by the Liebert XDCF's R-134a refrigerant.

2.1 References

This document must be used together with site-specific documentation and documentation for other parts of the system.

2.2 Parts Included With Liebert XDCF

- Installation manual (this document)
- Liebert XDCF module
- Mounting kit parts with the following items:

Lower Module		Upper Module	
Part	Qty	Part	Qty
Lower mounting bracket	1	Top unit mounting angle	1
Top deflector panel (two-pieces)	1	Bottom deflector panel (two-pieces)	1
Liebert XD Flex Pipe retainers	3	Liebert XD Flex Pipe retainers	3
10-32 screws	3	10-32 screws	2
10-32 nut	2	10-32 nut	1
Liebert XD Flex Pipe support panel	1		

2.3 Room Preparation

The room should be well insulated and must have a sealed vapor barrier. The vapor barrier in the ceiling and walls can be a polyethylene film. Paint on concrete walls and floors should contain either rubber or plastic.



NOTE

The vapor barrier is the single most important requirement for maintaining environmental control in the conditioned space.

Outside or fresh air should be kept to a minimum when temperature and humidity must be tightly controlled. Outside air adds to the cooling, heating, dehumidifying and humidifying loads of the site. Doors should be properly sealed to minimize leaks and should not contain ventilation grilles.

2.4 Product/System Description

Upper and lower modules may be mounted on the rear of the Egenera BladeFrame. Each module, when attached to a fully loaded BladeFrame EX rack, has a nominal cooling capacity of 10kW (2.8 tons; 34,000 BTUh). Performance is based on:

- Entering fluid temperature—55°F (12.8°C) and
- Dew point—50°F (10°C) or lower.

The complete system consists of Liebert XDCF modules, piping and Liebert XDP or Liebert XDC (see **Figure 3** below).

Figure 3 Liebert XDCF hydraulic diagram

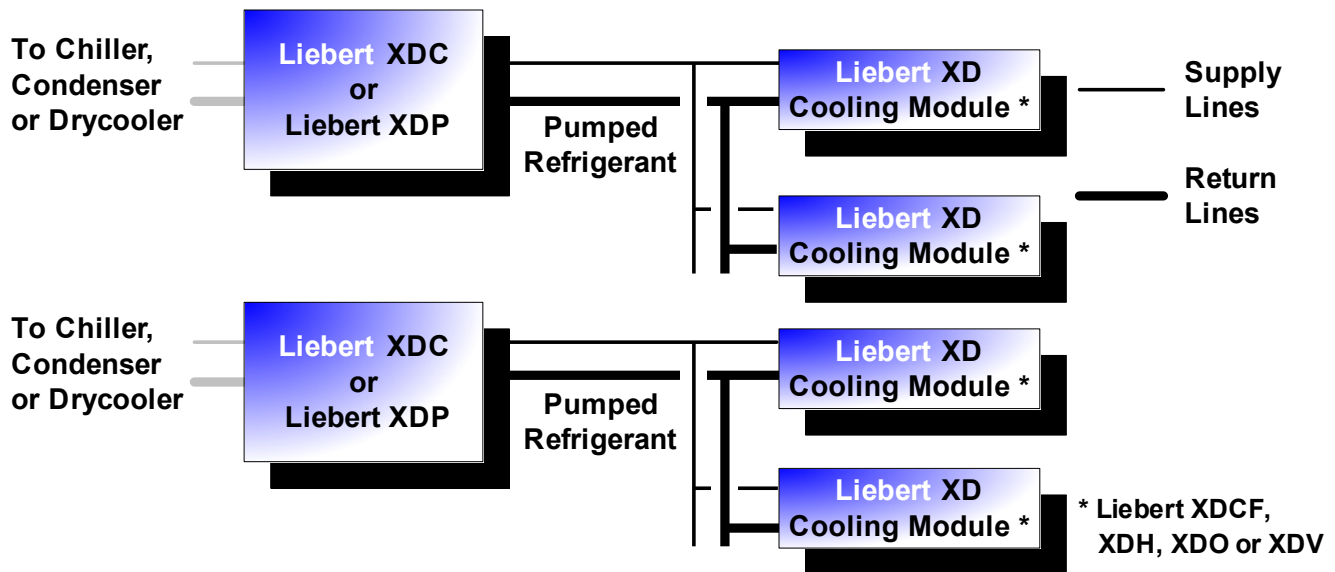

2.5 Equipment Inspection

Upon arrival of the unit, and before unpacking it, verify that the labeled equipment matches the bill of lading. Inspect all items for either visible or concealed damage. Damage should be immediately reported to the carrier and a damage claim filed with a copy sent to Liebert Corporation or to your sales representative.

CAUTION

Risk of sudden refrigerant discharge! Can cause loss of charge and minor injury.

Each Liebert XDCF unit is shipped with a full charge of R-134a refrigerant under pressure. Do not remove the pipe caps or plugs before the unit is attached to an Egenera BladeFrame and ready for connection to Liebert XD Piping.

Supply and return fittings on the Liebert XDCF are one-shot connections. Do not disconnect one-shot connections after they have been connected. Disconnection will release pressurized R-134a refrigerant from the Liebert XDCF.

2.5.1 Unit Handling

When unpacking and handling the unit, exercise extra care to prevent damage.

If multiple Liebert XDCF units are delivered, they will be shipped on a pallet. A pallet jack will be required to move these units to the installation location. When using a pallet jack, ensure that it has the size and length needed for safe handling of the pallet.

2.6 Unpacking the Liebert XDCF

The unit is shipped in a protective package. Do not remove the packaging from the Liebert XDCF before it is at the installation location.

- When unpacking and handling the Liebert XDCF, care should be taken to prevent damaging the coils.
- Remove outer packaging when ready to install the Liebert XDCF.
- Do not use unit piping to lift or move the Liebert XDCF.

2.6.1 Recyclable Packaging

All material used to package this unit is recyclable. Please save for future use or dispose of the material appropriately.



CAUTION

Risk of sharp edges, splinters and exposed fasteners! Can cause personal injury!

Only properly trained personnel wearing appropriate safety headgear, gloves, shoes and glasses should attempt to move, lift, remove packaging from, or prepare unit for installation.

NOTICE

Risk of unit damage if improperly stored. Keep the unit indoors and protected from dampness, freezing temperatures and contact damage.

Figure 4 Unpacking the Liebert XDCF

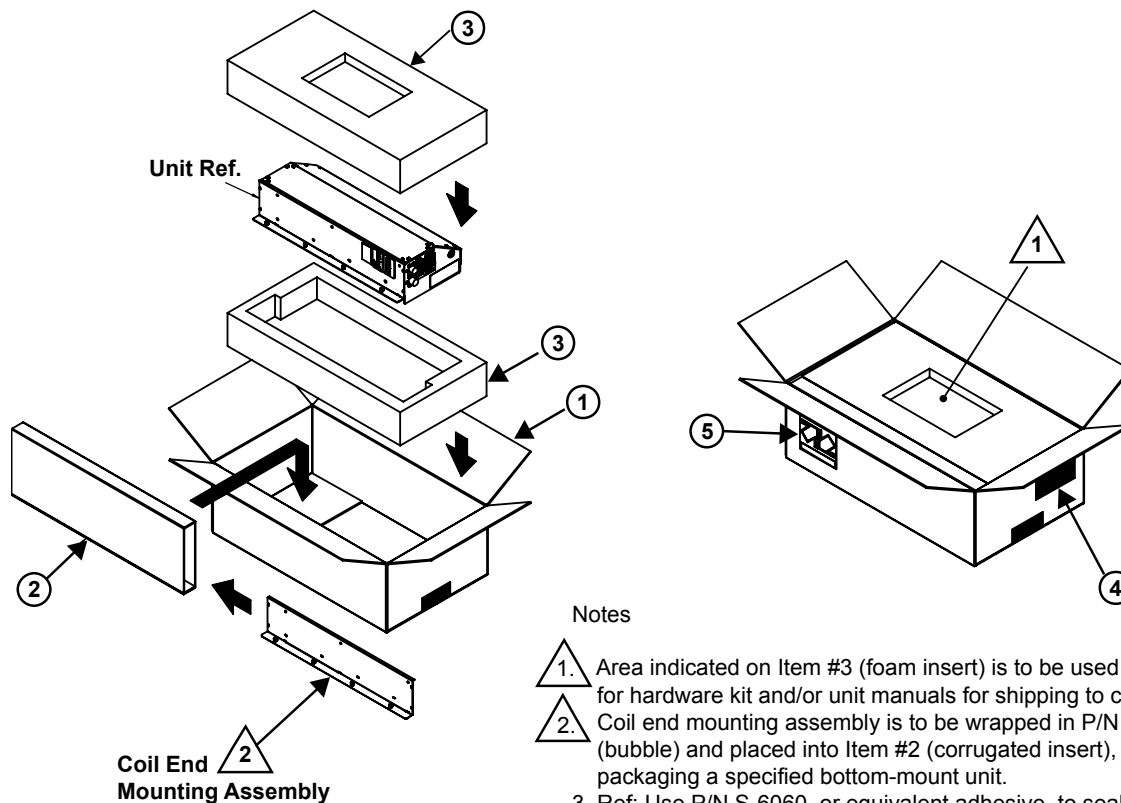

Notes

1. Area indicated on Item #3 (foam insert) is to be used for hardware kit and/or unit manuals for shipping to customer.
2. Coil end mounting assembly is to be wrapped in P/N 123783P1 (bubble) and placed into Item #2 (corrugated insert), only when packaging a specified bottom-mount unit.
3. Ref: Use P/N S-6060, or equivalent adhesive, to seal the top and bottom of Item #1 (box) for shipping to the customer.
4. Refer to manufacturing work instructions for any additional directions regarding packaging of this unit.

182713

3.0 MECHANICAL CONSIDERATIONS

The Liebert XDCF is engineered to fit on the rear of the Egenera BladeFrame enclosure. **Figure 5**, below, illustrates the unit's dimensions and the location of pipes. **Figure 6** shows the attachment positions of each module.

Figure 5 Overall dimensions

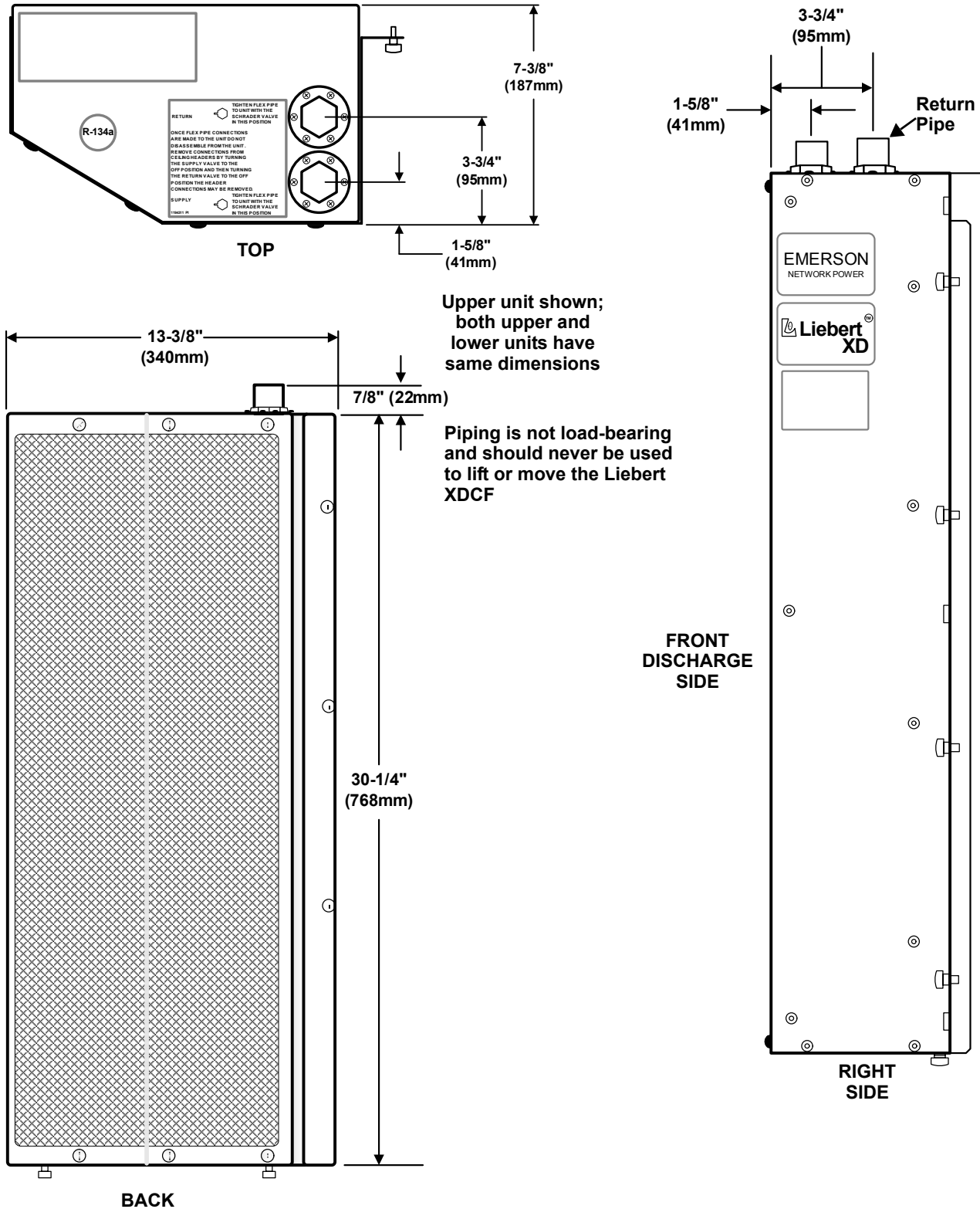

4.0 INSTALLATION

4.1 References

This document must be used together with site-specific documentation and documentation for other parts of the system.

4.2 Installation Considerations

Liebert XDCF modules must be securely mounted to the rear of the Egenera BladeFrame cabinet. No cutting or drilling is required to attach the modules; all mounting holes, slots and pins required are fabricated at the factory.

If only one Liebert XDCF will be attached to an Egenera BladeFrame cabinet, Liebert recommends using the lower Liebert XDCF module. If both an upper and a lower Liebert XDCF module will be attached, attach the lower unit first.

Liebert XDCF modules attach beside the power modules on the rear of the Egenera BladeFrame (see **Figure 6**).

Figure 6 Liebert XDCF unit mounting locations

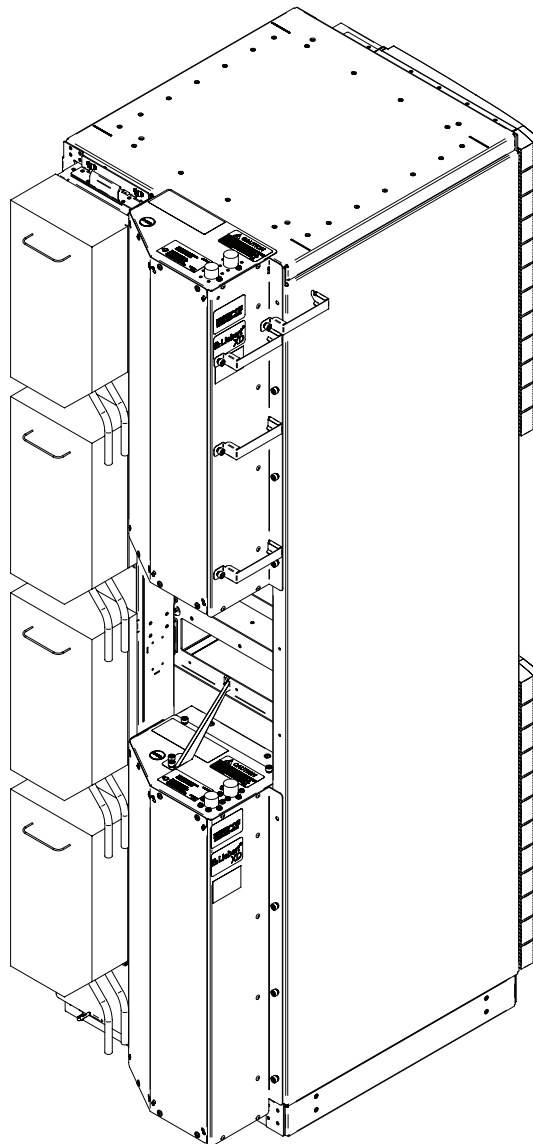

4.3 Mounting Lower Liebert XDCF Module

The lower Liebert XDCF module attaches to the Egenera BladeFrame cabinet with a mounting bracket, four bolts and a metal stud.

Before the Liebert XDCF is mounted, the mounting bracket and a two-piece deflector panel must be attached to its top surface and insulation must be applied to the left side.

4.3.1 Preparing the Lower Module for Attachment

1. Position the mounting bracket over the two mounting holes. The holes are near the center of the top of the Liebert XDCF module (see **Figure 7**).
2. Use two captive panel fasteners to attach the mounting bracket to the top of the Liebert XDCF module. Tighten the fasteners securely, using a screwdriver, either a blade-type or Phillips.
3. Position the top deflector over the two mounting holes along the front edge of the top of the lower Liebert XDCF module (see **Figure 7**). The flanges along the edge should be on the bottom.
4. Use two captive panel fasteners to attach the top deflector to the top of the lower Liebert XDCF module. Tighten the fasteners securely, using a screwdriver, either a Phillips or a blade-type.
5. Position the second piece of the top deflector along the front edge of the deflector piece attached in **Steps 3** and **4**, matching the mounting slots in the two pieces. The flanges along the edge should be on the bottom.
6. Use two captive panel fasteners to connect the deflector pieces. Tighten the fasteners finger-tight, leaving them loose enough to slide for good contact with the Egenera BladeFrame cabinet.

Figure 7 Lower Liebert XDCF attachments

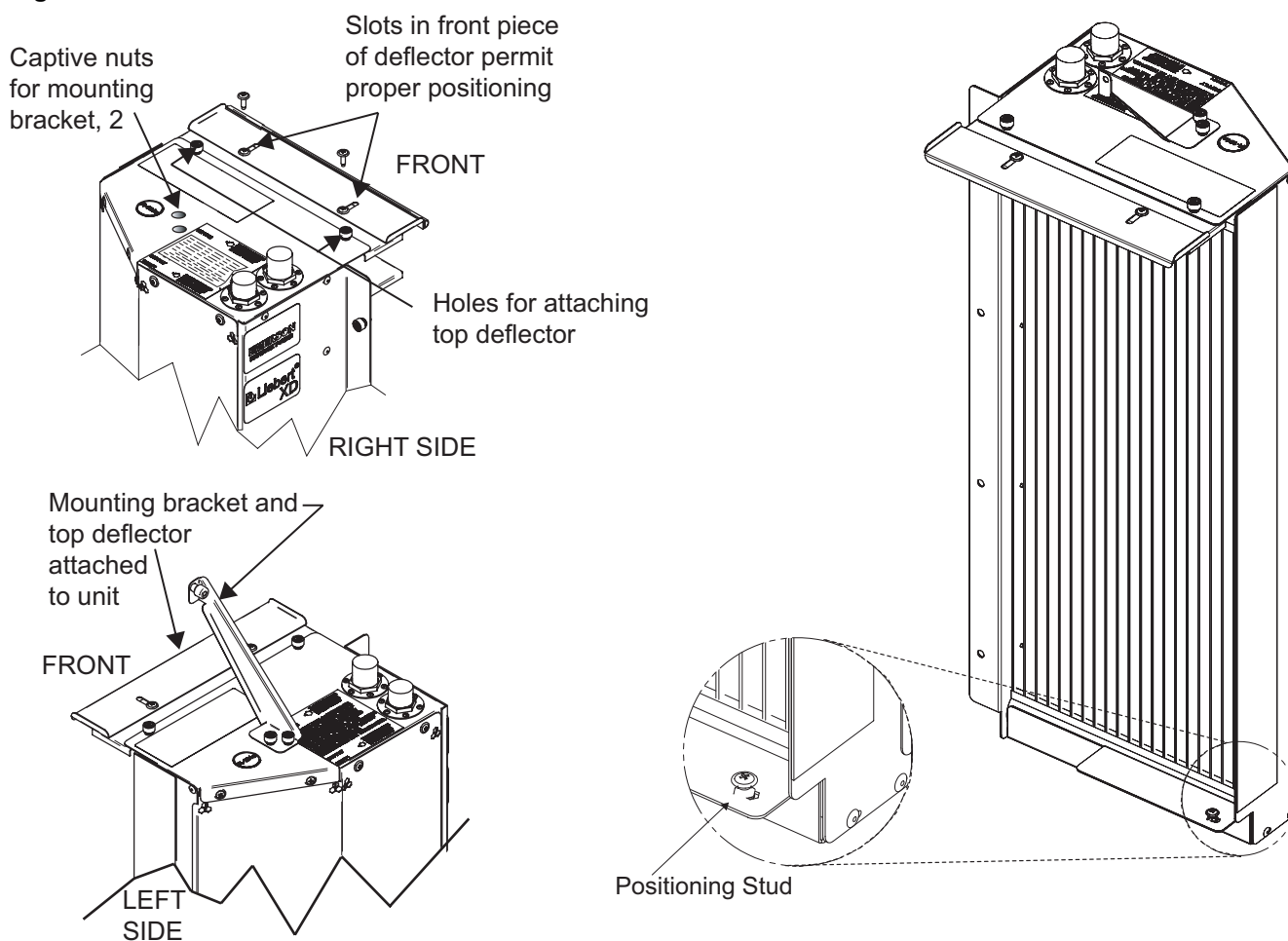

4.3.2 Attaching Lower Liebert XDCF Module

Liebert XDCF modules mount on the rear of the Egenera BladeFrame cabinet, near the power modules. The cabinet and Liebert XDCF have prefabricated mounting holes and studs to ease mounting.

1. Set the lower Liebert XDCF module on the left side of the ledge on the rear of the Egenera BladeFrame cabinet. Make sure the positioning stud on the bottom of the Liebert XDCF fits into the locator hole on the ledge as shown in **Figure 8**.

Figure 8 Locator hole for lower unit stud

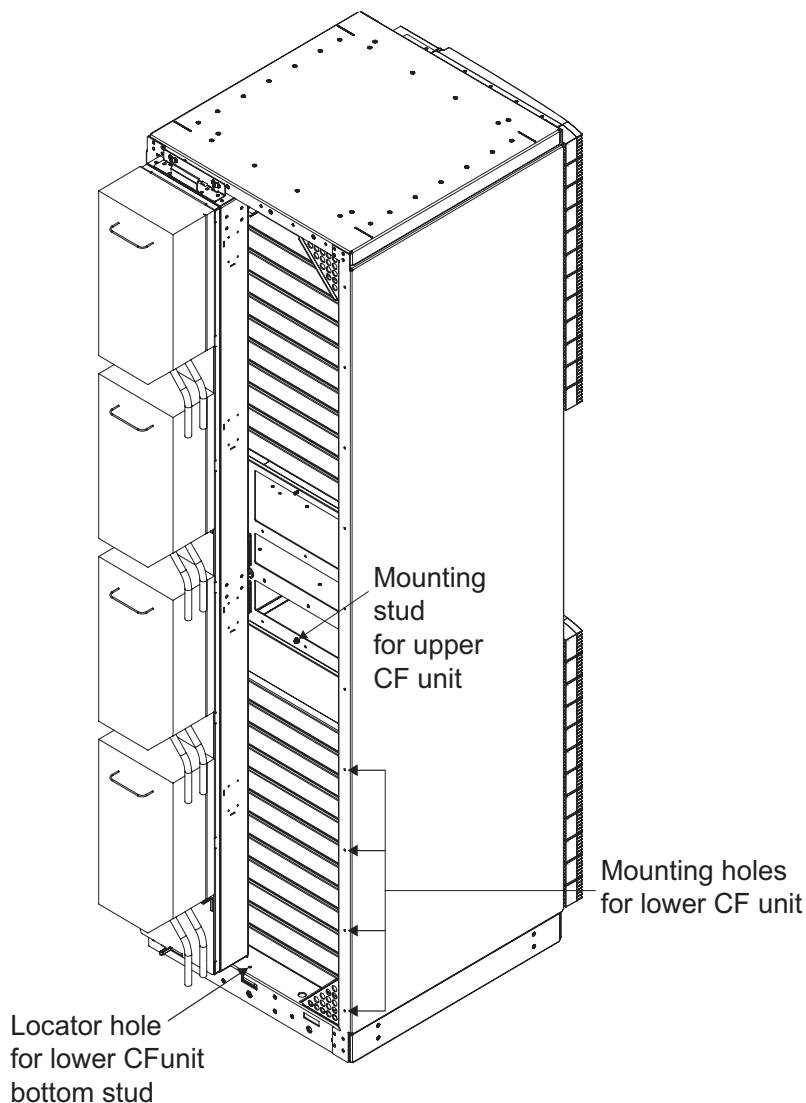

2. Press the Liebert XDCF against the Egenera BladeFrame cabinet.
3. Insert a panel fastener into the mounting bracket and screw it into the captive panel nut in the rear of the Egenera BladeFrame cabinet. For the hole locations, see **Figure 6**. Tighten the fasteners securely with a screwdriver, either a blade-type or Phillips.
4. Secure the Liebert XDCF to the cabinet by inserting and tightening four screws along the right side of the Liebert XDCF (see **Figure 7**).
5. Press the front section of the top deflector against the Egenera cabinet and tighten the panel fasteners joining the two-piece deflector.



NOTE

If a lower module and an upper module will be attached to the Egenera cabinet, proceed to 4.4 - Attaching Upper Liebert XDCF Module.

Attaching Liebert XD Flex Pipe Support Panel

Use of only the lower Liebert XDCF module requires attaching a Liebert XD Flex Pipe support panel and three pipe retainers. The retainers keep the refrigerant pipes behind the Egenera cabinet. If an upper Liebert XDCF module will be used, the Liebert XD Flex Pipe retainers will be attached to the upper module.

To attach the Liebert XD Flex Pipe support panel:

1. Position the Liebert XDCF Liebert XD Flex Pipe support panel over the line of four holes above the right edge of the lower Liebert XDCF module
2. Secure the Liebert XD Flex Pipe support panel to the cabinet by inserting and tightening four screws on the panel's flange. Tighten the fasteners securely with a screwdriver, either a Phillips or a blade-type.
3. Attach the three pipe retainers:
 - a. Slip the front end of a retainer into a slot on the Liebert XD Flex Pipe support panel.
 - b. Insert a panel fastener into the retainer and thread it into the captive panel nut.
 - c. Tighten the fastener securely, using a screwdriver, either a blade-type or Phillips.
 - d. Repeat **Steps a** and **c** for the other retainers.

Figure 9 Liebert XD Flex Pipe support panel attachment

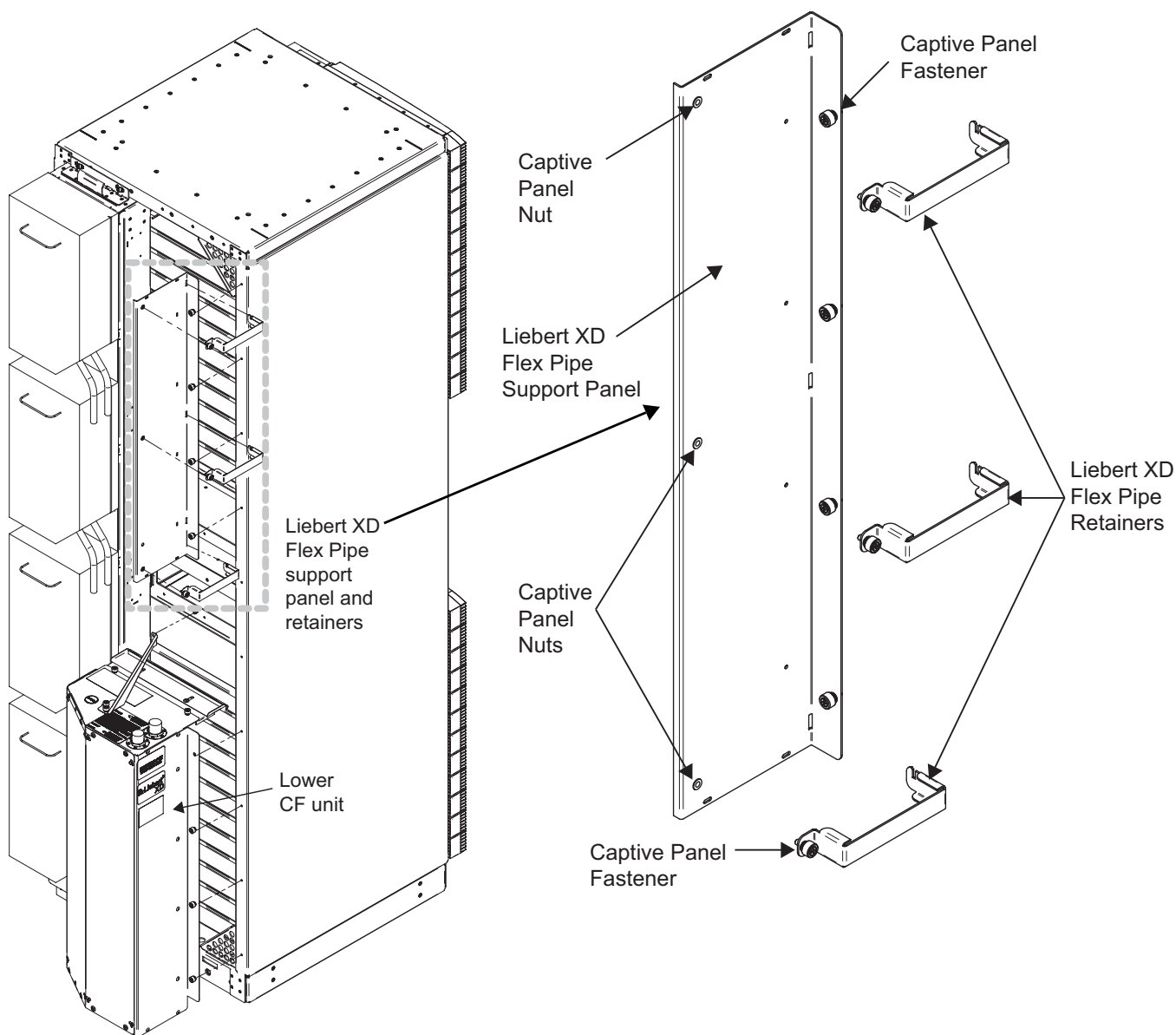

4.4 Attaching Upper Liebert XDCF Module

The upper Liebert XDCF module attaches to the Egenera BladeFrame cabinet with a mounting angle and four bolts.

Before the Liebert XDCF is mounted, the mounting angle and a two-piece deflector panel must be attached to the bottom of the Liebert XDCF and insulation must be applied to the left side.

4.4.1 Preparing the Upper Module for Attachment

1. Position the mounting angle over the two mounting holes. The holes are near the center of the bottom of the Liebert XDCF module (see **Figure 7**).
2. Use two captive panel fasteners to attach the mounting angle to the bottom of the Liebert XDCF module. Tighten the fasteners securely, using a screwdriver, either a blade-type or Phillips.
3. Position the bottom deflector over the two mounting holes along the front edge of the bottom of the upper Liebert XDCF module (see **Figure 10**). The flanges along the edge should be on the top side.
4. Use two captive panel fasteners to attach the bottom deflector to the bottom of the upper Liebert XDCF module. Tighten the fasteners securely with a screwdriver, either a Phillips or a blade-type.
5. Position the second piece of the bottom deflector along the front edge of the deflector piece attached in **Steps 3** and **4**, matching the mounting slots in the two pieces. The flanges along the edge should be on the top side.
6. Use two captive panel fasteners to connect the deflector pieces. Tighten the fasteners finger-tight, leaving them loose enough to slide for good contact with the Egenera BladeFrame cabinet.

Figure 10 Upper Liebert XDCF attachment

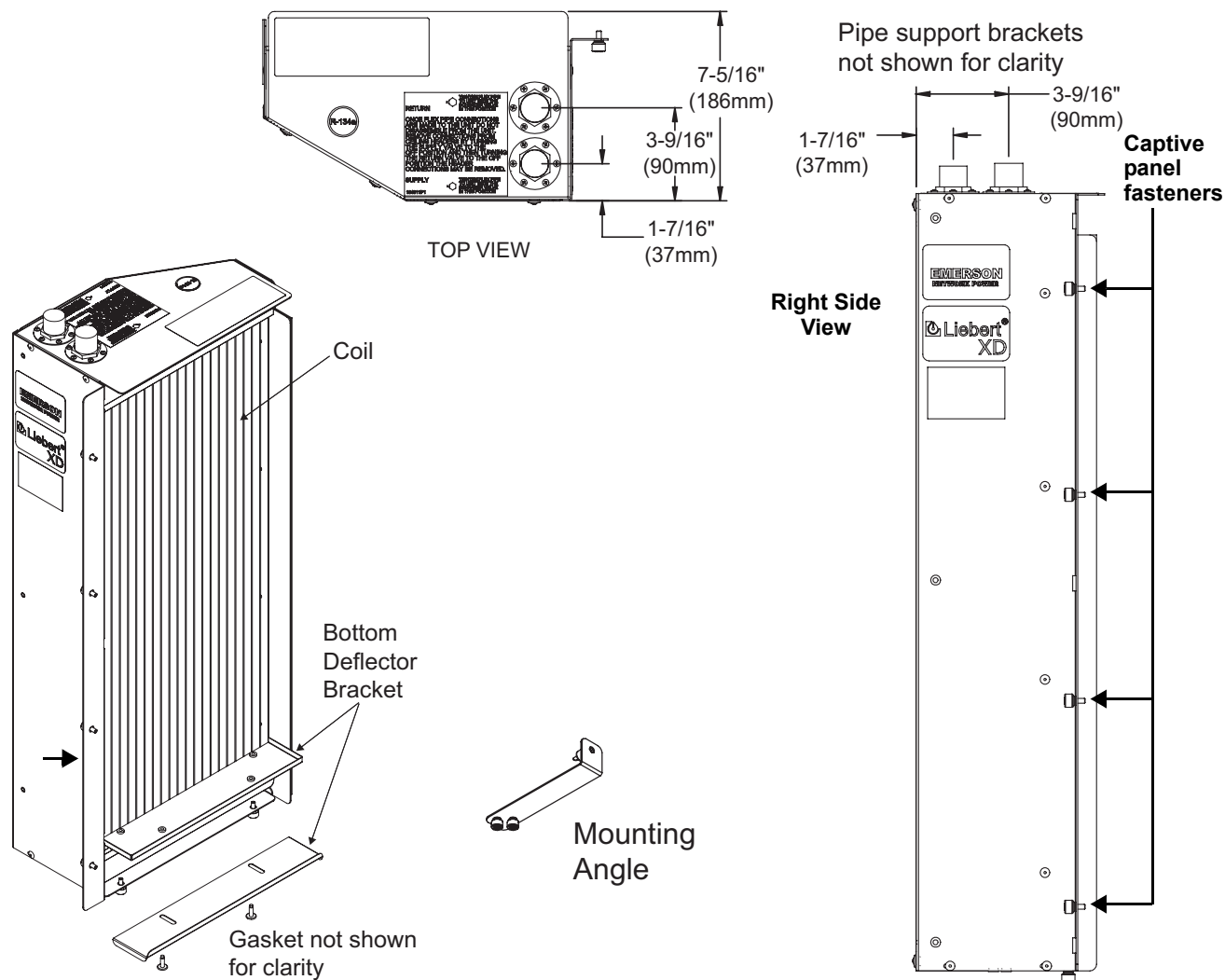

4.4.2 Attaching Upper Liebert XDCF Module

The upper Liebert XDCF module mounts on the rear of the Egenera BladeFrame cabinet, above the lower Liebert XDCF module. The cabinet and Liebert XDCF have prefabricated mounting holes and studs to ease mounting.

1. Attach the mounting angle to the bottom of the Egenera BladeFrame cabinet with a 10-32 nut that fits onto the stud on the back of the cabinet, see **Figure 6**).
2. Hang the upper Liebert XDCF module on the top of the Egenera BladeFrame cabinet, using the overhanging front edge of the Liebert XDCF. The bottom should rest on the mounting angle attached in **Step 1**.
3. Hold the Liebert XDCF against the Egenera cabinet.
4. Insert a panel fastener into the mounting angle and screw it into the captive panel nut in the rear of the Egenera BladeFrame cabinet. Tighten the fasteners securely with a screwdriver, either a Phillips or a blade-type.
5. Secure the Liebert XDCF to the cabinet four captive panel fasteners along the right side of the Liebert XDCF. For the hole locations, see **Figure 6**.
6. Press the front section of the bottom deflector against the Egenera cabinet and tighten the panel fasteners joining the two-piece deflector.

Attaching Liebert XD Flex Pipe Retainers to Upper Liebert XDCF Module

Liebert XD Flex Pipe retainers must be attached to the upper Liebert Liebert XDCF module to keep the refrigerant pipes positioned behind the Egenera cabinet.

To attach the three retainers to the upper Liebert XDCF module:

1. Slip the front end of a Liebert XD Flex Pipe retainer into a slot on the right side of the Liebert XDCF.
2. Insert a panel fastener into the retainer and thread it into the captive panel nut.
3. Tighten the fastener securely with a screwdriver, either Phillips or a blade-type.
4. Repeat **Steps 1** and **3** for the remaining retainers

Figure 11 Attaching Liebert XD Flex Pipe retainers

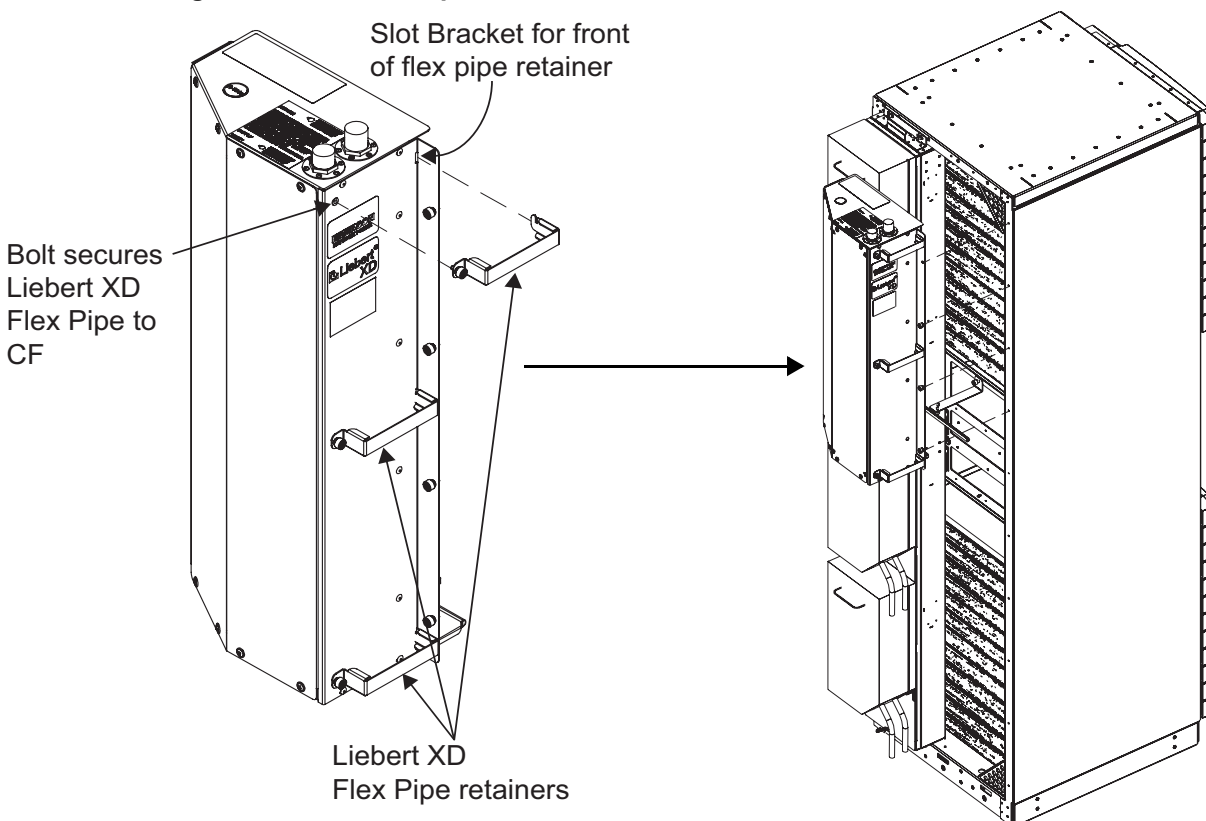

5.0 PIPING CONNECTIONS AND PIPING ACCESS POINTS

Refer to site specific drawings for general locations of the piping connections. For Liebert XDCF connection locations, refer also to **Figure 12**.

5.1 European Union Fluorinated Greenhouse Gas Requirements

Stationary air conditioning, refrigeration, heat pump equipments and stationary fire protection systems in the European Community market and operating with fluorinated greenhouse gases (f-gas), such as R407C, R134a, R410A, must comply with the F-Gas Regulation: (EC) No. 842/2006 (F-gas). The regulation prohibits, among other actions, venting fluorinated greenhouse gases to the atmosphere.

The F-Gas Regulation requires operators to use all measures that are technically feasible and do not entail disproportionate cost to prevent leakage of these gases, to test for leakage regularly and to recover f-gas before disposing of equipment, as well as during service and maintenance.

Refer to the full regulation for additional details.

5.2 Connection Methods and Points

The assembly and connection means used for piping in the Liebert XD system are the same as those used in conventional refrigeration systems. Observe all standard practices during installation and startup to prevent damage and contamination.

Supply piping connection is 1/2" OD copper pipe, and return piping connection is 5/8" OD copper. Both supply and return fittings are one-shot connections. These fittings contain pressurized R-134a refrigerant inside the Liebert XDCF.



CAUTION

Risk of sudden refrigerant discharge! Can cause loss of charge and minor injury!

Do not disconnect one-shot connections after they have been connected. Disconnection will release pressurized R-134a refrigerant from the Liebert XDCF.

The Liebert XDCF has supply and return piping access on the top of each module.

5.2.1 Header System

The Liebert XDCF module system requires use of the Liebert XD prefabricated piping assembly. The prefabricated piping is compatible with the Liebert XD Flex Pipe required to attach to the Liebert XDCF modules.

Figure 12 Liebert XDCF supply and return piping access points

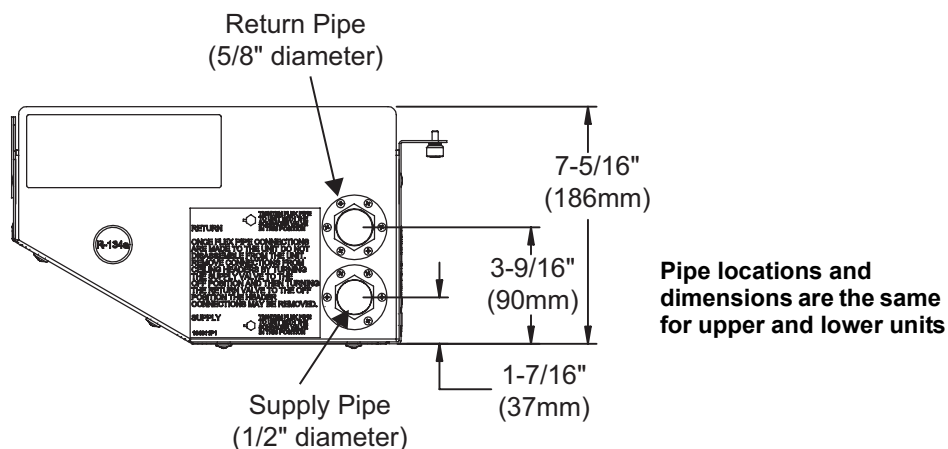

For additional information, refer to the Liebert Xtreme Density System Design Manual, SL-16655.

5.3 Recommended Piping Size

Connect the main pipes between the Liebert XDCF branch piping and the Liebert XDP or Liebert XDC according to **Table 1**. Elbows and restrictions must be minimized to get good fluid flow.

Connect the branch pipes between the main piping and the Liebert XDCF according to **Table 1**.

Table 1 Branch piping sizes for refrigerant loop

Pipe Function	Size / Equivalent Pipe Length
Liebert XDP/Liebert XDC supply line, from Liebert XDP/Liebert XDC supply to farthest Liebert XDCF	1-1/8" OD (1.025" ID) for lengths up to 60 feet (18m)
	1-3/8" OD (1.265" ID) for lengths over 60 but less than 175 feet (18 to 53m)
Liebert XDP/Liebert XDC return line, from farthest Liebert XDCF to Liebert XDP/Liebert XDC return	2-1/8" OD (1.985" ID) for lengths up to 60 feet (18m)
	2-5/8" OD (2.465" ID) for lengths over 60 but less than 175 feet (18 to 53m)
From Liebert XDCF supply to supply line of Liebert XDP/Liebert XDC	1/2" OD (0.430" ID) for lengths up to 6 feet (1.8m)
	5/8" OD (0.545" ID) for lengths over 6 feet but less than 35 feet (1.8-10.6m)
From Liebert XDCF return to return line of Liebert XDP/Liebert XDC	5/8" OD (0.545" ID) for lengths up to 6 feet (1.8m)
	7/8" OD (0.785" ID) for lengths over 6 feet but less than 35 feet (1.8-10.6m)

5.4 Connecting Liebert XD Flex Pipes to Liebert XDCF Modules

1. Remove the caps on the supply and return lines on the top of the Liebert XDCF.
2. Lubricate the threads, diaphragm and O-ring with one or two drops of mineral oil.
3. Connect the line-set coupling finger-tight.
4. Make sure the Schrader valve is properly oriented; refer to the label on the top of the Liebert XDCF.
5. Hold the backup hex nut with a wrench while tightening the swivel nut.
6. Tighten the swivel nut on the female coupling until it is seated or a definite resistance is felt.
7. Once a definite bottoming resistance is felt (as in metal to metal), place a mark lengthwise from the swivel nut to the backup hex and tighten the swivel nut on the female coupling an additional 1/4 turn.
8. Tighten both the supply fittings and the return fittings to 35-45 ft/lb (47-61Nm).
9. Mark the female and male coupler with for future reference.

5.5 Connecting a Liebert XDCF with Liebert XD Flex Pipe to an Operational Liebert XD System



NOTE

Before connecting the Liebert XDCF with Liebert XD Flex Pipe to the prefabricated piping mains, check the entire system for leaks.

Check the Liebert XDCF to ensure that the unit has no refrigerant leaks.

Read all instructions before beginning installation.

Tools Required

- Two adjustable wrenches, with a maximum adjustment size of 2-1/2 inches
- Screwdriver, Phillips or blade type



NOTE

This operation requires two people.

1. Determine the port location of the supply and return piping overhead
2. Make sure the service valve for each port is closed
3. Remove cap for only the required ports. Do not remove caps from the unused ports.
4. Once **Step 3** has been completed, remove the pipe plugs that are supplied on the Liebert XD Flex Pipe.

Figure 13 Liebert XD prefabricated piping assembly

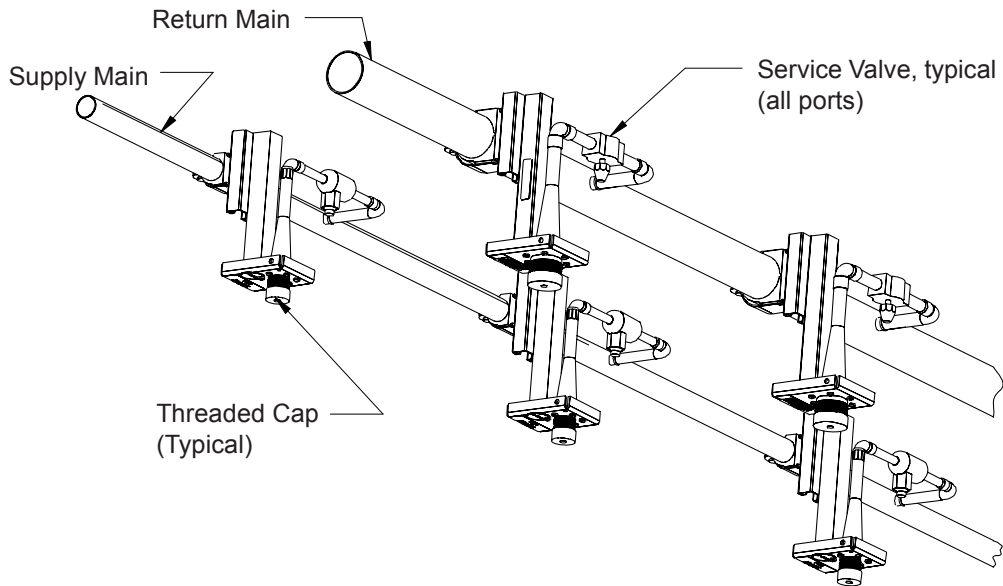

5. Thread the return couplers together, the larger of the two couplers (Liebert XD Flex Pipe and return main).
6. Use one of the adjustable wrenches to hold the fixed side of the female coupler on the Liebert XD CF stationary. With the other adjustable wrench, tighten the collar onto the coupler. Tighten these only until the force required to tighten abruptly increases. See **Figure 14**.

NOTICE

Do not overtighten the couplers. Overtightening of couplers will damage the couplers.

Figure 14 Detail view of Liebert XD Flex Pipe and prefabricated piping port

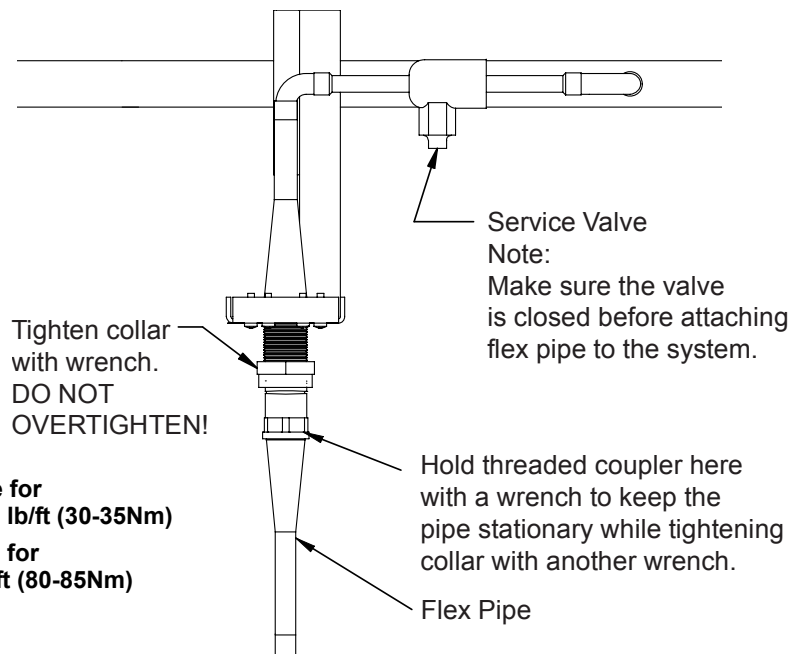

Supply Side Torque Range for 1/2" coupler is 22.1 to 25.8 lb/ft (30-35Nm)

Return Side Torque Range for 1" coupler is 59 to 62.7 lb/ft (80-85Nm)

7. Repeat **Steps 5** and **6** for the smaller coupler (supply line).
8. Once the supply and return connections are completed, open the return service valve, then open the supply service valve.

With the equipment running, cool air is discharged from the back of the Liebert XD CF.

Figure 15 Liebert XD system with prefabricated piping assembly and Liebert XD Flex Pipe

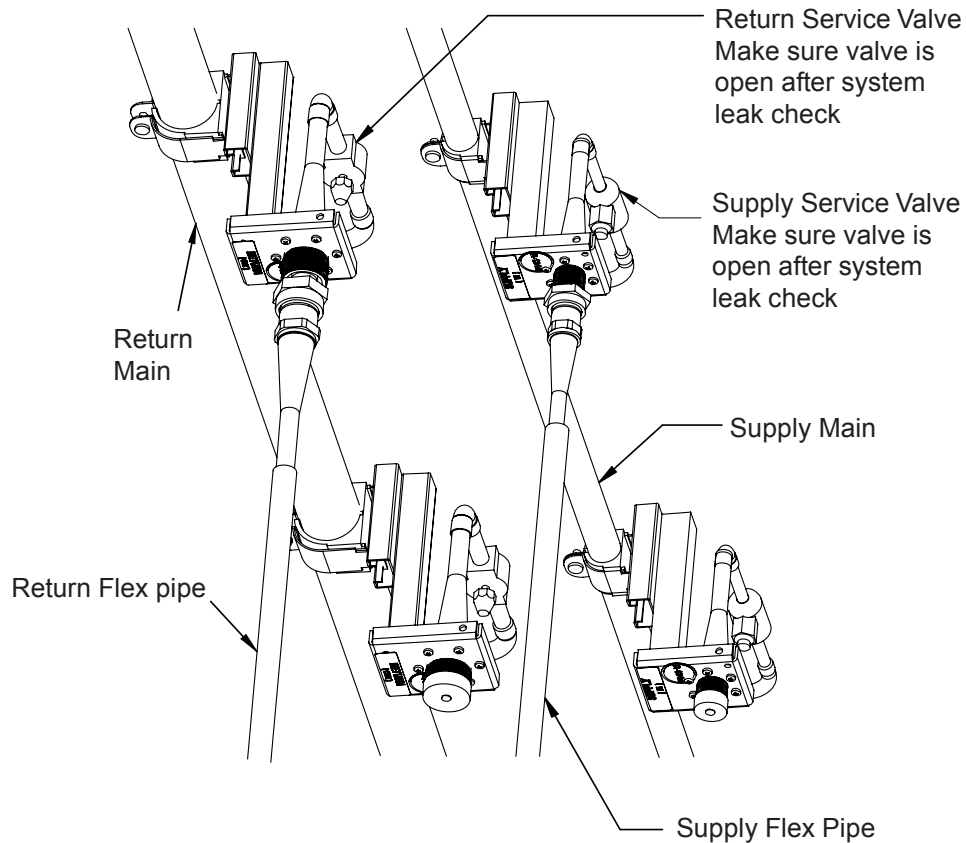

5.6 Disconnecting a Liebert XDCF With Liebert XD Flex Pipe From a Liebert XD System



NOTE

Before uninstalling a Liebert XDCF with Liebert XD Flex Pipe from the prefabricated piping mains: Close the supply service valve, wait approximately two minutes, then close the return service valve.

Read all instructions before beginning.

Tools Required

- Two adjustable wrenches, maximum adjustment size of 2-1/2 inches
 - Phillips head #2 screwdriver
1. Close the service valve in the supply line to the Liebert XDCF (smaller coupler).
 2. Close the service valve in the return line to the Liebert XDCF (larger coupler).
 3. Locate and have at the ready the caps and plugs for both ends of the supply and return couplers.
 4. Loosen the female supply coupler from the male supply coupler (smaller coupler). This requires two adjustable wrenches. Refer to **Figure 14**.
 5. The Liebert XDCF side of the female coupler must be held stationary while the collar on the coupler is being loosened. Refer to **Figure 14**.
 6. Disconnect the coupler.

Figure 16 Profile view of the Liebert XD system

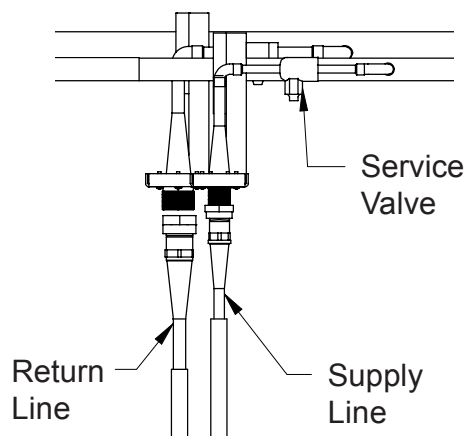

7. Place the protective dust cap and plug back onto both ends of the coupler on the Liebert XDCF and the port pipe.

Figure 17 Piping mains without Liebert XDCF and Liebert XD Flex Pipe

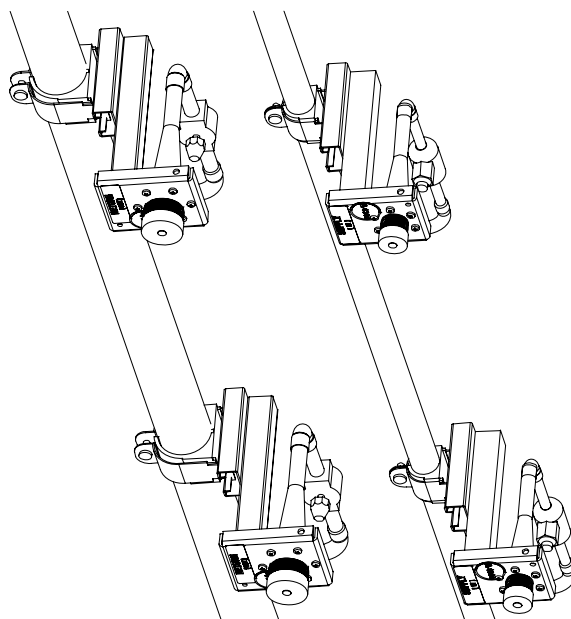

8. Repeat **Steps 5** through **7** for the return coupler (larger coupler).
9. Carefully lay the Liebert XD Flex Pipe aside.

NOTICE

Do not fold or bend Liebert XD Flex Pipe. Kinks in the tubing can cause permanent damage to the Liebert XD Flex Pipes.

10. Carefully unbolt the Liebert XDCF from the cabinet.
11. Place the Liebert XDCF on a stable surface.

5.7 Insulation

To minimize the possibility of condensation, insulate all piping between the Liebert XDCF and the Liebert XDP or Liebert XDC.

6.0 CHECKLIST FOR PROPER INSTALLATION

- ___ 1. Liebert XDCF modules are securely attached to the cabinet.
- ___ 2. Piping from Liebert XDP or Liebert XDC, with isolation valves, properly connected to each Liebert XDCF module.
- ___ 3. Flex piping connections to prefabricated header assembly are secure and according to specifications.
- ___ 4. Check the R-134a refrigerant charge.
- ___ 5. System checked for leakage.
- ___ 6. Run system and verify that the Liebert XDP or Liebert XDC and the Liebert XDCF modules operate properly.
- ___ 7. Piping is insulated.

7.0 MAINTENANCE

Minimal maintenance is required to keep the Liebert XDCE operating at optimal levels. The unit should be cleaned and checked for damage. Suggested maintenance includes:

- Cooling fins—Clean any dust and debris from the cooling fins, taking care not to bend them.

7.1 Fluorinated Greenhouse Gas Requirements

Stationary air conditioning, refrigeration, heat pump equipments and stationary fire protection systems in the European Community market and operating with fluorinated greenhouse gases (f-gas), such as R407C, R134a, R410A, must comply with the F-Gas Regulation: (EC) No. 842/2006 (F-gas). The regulation prohibits, among other actions, venting fluorinated greenhouse gases to the atmosphere.

The F-Gas Regulation requires operators to use all measures that are technically feasible and do not entail disproportionate cost to prevent leakage of these gases, to test for leakage regularly and to recover f-gas during equipment service and maintenance and before disposing of equipment.

Refer to the full regulation for additional details.

8.0 SPECIFICATIONS

Table 2 Liebert XDCF specifications

Models	XD-CF-10-TPE-0, XD-CF Top EXP XD-CF-10-TP-0, XD-CF Top XD-CF-10-BPE-0, XD-CF BTM EXP XD-CF-10-BP-0, XD-CF BTM	
Cooling capacity, maximum	10kWH / 2.8 Tons / 34,000 BTUh	
Conditions	55°F (13°C) entering fluid temperature, 50°F (10°C) or lower dew point	
Dimensions, inches (mm)		
Height – including pipe connections	31-3/8" (797mm)	
Width	13-7/16" (341mm)	
Depth	7-5/16" (186mm)	
Weight, lb (kg)		
Unit only	18 (8.2)	
Shipping	30 (13.6)	
Pipe connections		
Refrigerant supply from Liebert XDP/Liebert XDC	1/2" threaded one-shot coupling on the unit	
Refrigerant return to Liebert XDP/Liebert XDC	5/8" threaded one-shot coupling on the unit	
Cabinet exterior finish	Gray	
Agency		
Safety	CSA, CE Approved	

NOTES

Ensuring The High Availability Of Mission-Critical Data And Applications.

Emerson Network Power, the global leader in enabling business-critical continuity, ensures network resiliency and adaptability through a family of technologies—including Liebert power and cooling technologies—that protect and support business-critical systems. Liebert solutions employ an adaptive architecture that responds to changes in criticality, density and capacity. Enterprises benefit from greater IT system availability, operational flexibility and reduced capital equipment and operating costs.

Technical Support / Service Web Site

www.liebert.com

Monitoring

800-222-5877

monitoring@emersonnetworkpower.com

Outside the US: 614-841-6755

Single-Phase UPS

800-222-5877

upstech@emersonnetworkpower.com

Outside the US: 614-841-6755

Three-Phase UPS

800-543-2378

powertech@emersonnetworkpower.com

Environmental Systems

800-543-2778

Outside the United States

614-888-0246

Locations

United States

1050 Dearborn Drive

P.O. Box 29186

Columbus, OH 43229

Europe

Via Leonardo Da Vinci 8

Zona Industriale Tognana

35028 Piove Di Sacco (PD) Italy

+39 049 9719 111

Fax: +39 049 5841 257

Asia

7/F, Dah Sing Financial Centre

108 Gloucester Road, Wanchai

Hong Kong

852 2572220

Fax: 852 28029250

While every precaution has been taken to ensure the accuracy and completeness of this literature, Liebert Corporation assumes no responsibility and disclaims all liability for damages resulting from use of this information or for any errors or omissions.

© 2008 Liebert Corporation

All rights reserved throughout the world. Specifications subject to change without notice.

® Liebert is a registered trademark of Liebert Corporation.

All names referred to are trademarks

or registered trademarks of their respective owners.

SL-16678_REV05_05-08

Emerson Network Power.

The global leader in enabling *Business-Critical Continuity*.

■ AC Power

■ Embedded Computing

■ Outside Plant

■ Racks & Integrated Cabinets

■ Connectivity

■ Embedded Power

■ Power Switching & Controls

■ Services

■ DC Power

■ Monitoring

■ Precision Cooling

■ Surge Protection

Business-Critical Continuity, Emerson Network Power and the Emerson Network Power logo are trademarks and service marks of Emerson Electric Co.

©2008 Emerson Electric Co.