



# **Perle10/100/1000 Ethernet Extended Temperature Media Converters**

---

## ***Installation Guide*** ***S-1110-XT***



## Overview

This document contains instructions necessary for the installation and operation of the Perle Standalone Extended Temperature 10/100/1000 rate converting Media Converters (S-1110-XT). These products have the ability to convert 10/100/1000Base-T cable connections (copper) to 100/1000Base-X connections (fiber). The fiber connection can be either single mode (SM) or multimode (MM) and can operate over different wavelengths and distances, depending on the model selected (see table below).

## Extended Temperature Models

Model	Connector (xx)	Mode Distance	Wavelength (TX/RX)
S-1110-M2xx05-XT	SC/ST	MM 550 m/1804	850 nm
S-1110-S2xx10-XT	SC/ST	SM 10 km/6.2 mi.	1310 nm
S-1110-S1SC10U-XT	SC	SM 10 km/6.2 mi.	1310/1490 nm
S-1110-S1SC10D-XT	SC	SM 10 km/6.2 mi.	1490/1310 nm
S-1110P-SFP-XT	SFP	<b>Note 1.</b>	

**Note 1:** Fiber characteristics will depend on the SFP fiber module selected.

Please visit Perle's website for the most up to date Installation guides models and specifications.

<http://www.perle.com/>

# Installation

The default DIP switch settings (all switches in the UP position) will work for most installations.

These are the steps required to configure the Perle S-1110-XT Ethernet media converter:

1. Insert SFP Module (SFP Model only).
2. Set the Auto-MDIX jumper setting (optional).
3. Set the DIP switch settings (if required).
4. Set the Powering Option Jumpers (if required).
5. Install and connect the fiber cable(s).
6. Install and connect the copper cable(s).
7. Power up the media converter.

## Auto-MDIX Jumper Settings

**Note:** The factory settings for Auto-MDIX will work for most installations, but in the rare case that you need to modify the settings, the procedure is below.

To access the Auto-MDIX jumper settings, unscrew the six side screws on the case and remove the cover plate. Locate the MDIX AUTO jumper set as detailed below. By covering or strapping pins 1 and 2, the S-1110-XT will operate as an MDIX device. By covering or strapping pins 2 and 3, the S-1110XT will automatically detect the Ethernet cable's polarity. Removing the strapping is the same as AUTO.

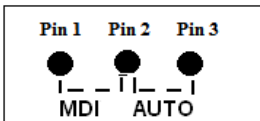

**Note:** The default jumper setting is AUTO

# DIP Switches

The DIP switches are accessible through the opening in the side of the enclosure.

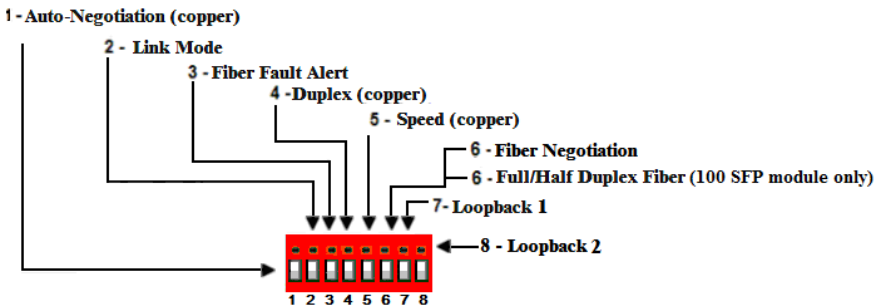
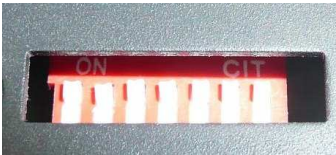

**Note:** All switch changes take effect immediately.

## DIP Switch Settings

### Auto Negotiation copper (Switch 1)

Switch Position	Copper
Up (default)	Auto
Down	Off

**Note:** Auto negotiation should only be turned off, if the copper link partner does not support Auto Negotiation and fixed settings are required by the copper link partner.

**Auto:** When enabled, the media converter will negotiate with its link partner to determine the most optimal parameters for this connection. The S-1110-XT will advertise capabilities of 10,100 and 1000 Mbps, full and half duplex as well as pause, and remote fault capabilities to the link partner.

If the copper link partner does not support Auto negotiation, the S-1110-XT will parallel detect to 10 or 100 Mbps and force Half Duplex mode as per IEEE specifications.

**Off:** When the Auto Negotiation switch is set to the OFF position, the media converter will not negotiate the Ethernet parameters with the copper link partner. The parameters used by the media converter will be determined by the Duplex (switch 4) and Speed (switch 5) DIP switch settings.

## ***Link Mode (Switch 2)***

<b>Switch Position</b>	<b>Mode</b>
Up (default)	Standard Mode
Down	Smart Link Pass-Through

**Standard Mode:** In this mode, link on the fiber and copper sides can be brought up and down independently of each other. A loss of link on either the fiber or copper port can occur without affecting the other connection.

**Smart Link Pass-Through** In this mode, the link state on one connection is directly reflected through the media converter to the other connection. If link is lost on one of the connections, then the other link will be brought down by the media converter.

If the installation has a media converter on both ends of the fiber link and both are set-up for Smart Link Pass-Through, then a loss of copper link on the far end device will propagate through both media converters and will result in a loss of link at the near end device.

## ***Fiber Fault Alert (Switch 3)***

<b>Switch Position</b>	<b>Fiber Port</b>
Up (default)	Enabled
Down	Disabled

**Enabled:** If the media converter detects a loss of signal on the fiber receiver, it will immediately disable its fiber transmitter signal on the same port. This, in effect, notifies the fiber link partner that an error condition exists on the fiber connection.

If the remote media converter is set up for Fiber Fault Alert (FFA) and the local media converter is set up with Link Pass-Through, a loss of fiber link will be passed through to the local copper connection thus notifying the connected device.

If the media converter has been set to Smart Link Pass-Through mode, the effect will be the same as FFA, since the link loss on the fiber receiver will result in bringing down the copper link, which will in turn cause the transmit fiber link to be brought down.

**Note:** This feature only takes effect if Fiber Negotiation has been turned off.

**Disabled:** The media converter will not monitor for or generate Fiber Fault Alert.

## Illustration of the FFA

The following diagram is an illustration of the operation of this feature.

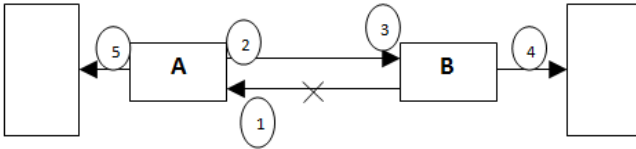

**(A)** – Remote Media Converter setup for Fiber Fault Alert Enabled, Fiber Negotiation – OFF and Link Mode – Standard.

**(B)** – Local Media Converter setup for Fiber Fault Alert Enabled, Smart Link Pass-Through On and Fiber Negotiation - OFF

1 – **(A)** Loses fiber connection on its receiver.

2 – **(A)** Sends FFA.

3 – **(B)** Detects FFA signal and shuts down the fiber link.

4 – **(B)** Drops link on copper connection because Smart Link Pass-Through is configured.

5 – **(A)** Link on copper connection is not affected because Smart Link Mode is set to Standard.

## Duplex copper (Switch 4)

Switch Position	Copper port
Up (default)	Full Duplex
Down	Half Duplex

**Note:** When Auto Negotiation (SW1) is set to Off, the media converter will use this Duplex setting for the copper port.

**Full Duplex:** In the Up switch position; the media converter will be set to Full Duplex mode.

**Half Duplex:** The media converter will be set to Half Duplex mode.

## ***Speed copper (Switch 5)***

<b>Switch Position</b>	<b>Copper port</b>
Up (default)	100
Down	10

**Note** When Auto Negotiation (SW1) is set to Off, the media converter will use this switch setting for the copper port speed.

**100:** When Switch 5 is in the Up position, the S-1110-XT will force the speed to 100 Mbps.

**10:** When Switch 5 is in the Down position the media converter will force the speed to 10 Mbps.

## ***Auto Fiber Negotiation (Switch 6)***

<b>Switch Position</b>	<b>Fiber 1000 Mbps</b>
Up (default)	Auto
Down	Off

**Auto:** The Media Converter will negotiate Ethernet parameters on the fiber connection. This will ensure that the most optimal connection parameters will be in effect. If connecting to another Perle Media Converter, this parameter should be set to Auto. The Media Converter Module will advertise 1000Mbps, Full and Half Duplex, no Pause.

**Off:** The Media Converter Module's fiber will be fixed to 1000Mbps, Full Duplex.

## ***When using a 100 Mbps SFP module Full/Half Duplex on Fiber (Switch 6)***

<b>Switch Position</b>	<b>Fiber 100 Mbps</b>
Up (default)	Full Duplex
Down	Half Duplex

**Full Duplex:** The Media Converter Module will be set to Full Duplex mode on its fiber link.



**Half Duplex:** The Media Converter Module will be set to Half Duplex mode on its fiber link.

## ***Loopback Fiber-1 (Switch 7)***

Switch Position	Mode
Up (default)	Disabled
Down	Enabled

**Disabled:** The loopback feature is disabled. This is default position for normal operation. The switch must be set to this position in order for data to pass through the media converter.

**Enabled:** This is a test mode. All data received on the receive (RX) fiber connection is looped back to the transmit (TX) fiber connection. The data link will be disabled; however power to the powered devices will be maintained. This mode will override all other switch settings.

## ***Installing the SFP Fiber Module***

SFP models only.

1. Locate the appropriate fiber module and insert the SFP into the opening on the front of the media converter.
2. Ensure the SFP module is properly seated. The release latch of the SFP fiber transceiver must be in the closed (up) position before insertion.
3. The SFP module may be inserted before or after applying power to the media converter.
4. Proceed with cable connections.

## ***Installing the Duplex Fiber Cable***

1. Locate a 1000Base-X compliant duplex (2 strands) fiber cable with appropriate connectors.
2. Connect the fiber cables from one media converter to the other media converter/switch/fiber device ensuring that the RX and TX are reversed (crossed) at the opposite end.



## ***Installing the Simplex Fiber Cable***

1. Locate a 1000Base-X compliant simplex (1 strand) fiber cable with appropriate connectors. Ensure that the TX wavelength matches the RX wavelength at the other end and the RX wavelength matches the TX wavelength at the other end.
2. Connect the fiber cable from one media converter to the other media converter/switch/fiber device.

## ***Installing the Copper Cable***

1. Locate 10/100/1000Base-T compliant copper cables with the appropriate connectors.
2. Connect the RJ-45 cable between the Perle media converter and the device.

**Note:** The Perle media converter supports Auto-MDIX which allows connection of a straight-through or cross-over Ethernet cable. See [Auto-MDIX Jumper Settings](#) in this guide for jumper positions.

## ***Grounding the Media Converter***

If your installation requires additional grounding this procedure can be followed.

Grounding the chassis requires the following items:

- One grounding lug (not provided).
- Grounding wire 12 to 18 AWG (not provided).
- Cross-head screwdriver (not provided).

**Note:** For your safety, when installing this equipment, always ensure that the chassis ground connection is installed first and disconnected last.

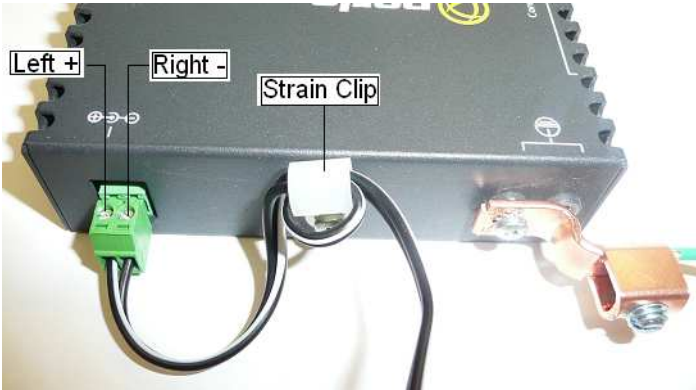

1. Attach the grounding lug to the ground wire.
2. Attach the lug to the chassis with the grounding screw(s).

## ***Powering up the Perle Media Converter***

### **Extended Temperature models are supplied with a Pluggable Terminal Block**

- Unplug the terminal block from the Media Converter.
- Ensure the Power Source is off.
- Strip both wires 5mm (3/16<sup>th</sup> inch)
- Loosen the terminal block screws and connect Positive (+) wire to the left terminal. Connect the Negative (-) wire to the right terminal. Tighten Terminal screws (0.22Nm-0.25Nm torque).
- Plug the terminal block into the Media Converter
- Turn on power source.
- Check that the PWR LED light is lit.
- For extra power cable strain relief, attach the strain clip to the case as shown below, and thread the power cable through the clip in either one or two loops.

# Operation

## Status LED

The Perle 10/100/1000 Rate converting Extended Temperature Media converters have status LEDs located on the front panel of the unit.

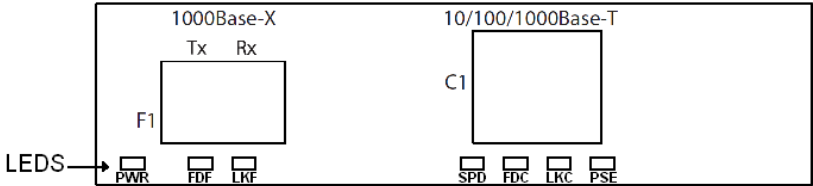

### PWR

**On** – Power is applied to the unit

**Blinking (slow)** – Loopback mode (one or both fiber interfaces are in loopback mode)

**Blinking (fast)** Power On failure. See LED Pattern to determine pattern combination and failure cause

### LED Pattern

FDF	LKF	FDC	PSE	
Off	Off	On	On	SFP incompatible
All other LED patterns				Internal hardware failure

### FDF- (Fiber Duplex)

**On** – Full Duplex

**Off** – Half Duplex

### LKF- (Status on Fiber Link)

**On** – Fiber link is present

**Off** – No fiber link present

**Blinking (slow)** – Fiber link appears functional – Fiber link has been brought down by Smart Link Pass-Through

**Blinking (fast)** – Fiber link up and receiving data

<p><b>SPD- (Copper Port)</b></p> <p><b>Green</b> – 1000 Mbps</p> <p><b>Orange</b> – 100 Mbps</p> <p><b>Off</b> – 10 Mbps (if link is currently established)</p>
<p><b>FDC- (Duplex on Copper)</b></p> <p><b>On</b> – Full Duplex Mode</p> <p><b>Off</b> – Half Duplex Mode</p>
<p><b>LKC- (Link Status on Copper port)</b></p> <p><b>On</b> – Copper link is present</p> <p><b>Off</b> – No copper link present</p> <p><b>Blinking (slow)</b> – Copper link appears functional – Copper link has been brought down by Smart Link Pass-Through.</p> <p><b>Blinking (fast)</b> – Copper link up and receiving data</p>

## ***Troubleshooting***

### ***General***

1. Ensure power source is connected.
2. Ensure the remote device's fiber connection type is compatible with the media converter. If using a simplex fiber connection, ensure that you have both an Upstream (U) and Downstream (D) media converter.
3. Ensure all cabling is of the correct type and is in good working order.
4. For duplex fiber connections, ensure the RX and TX has been reversed between the two media converters.

### ***No connectivity***

If unable to get full connectivity with all DIP switches in the UP position, this procedure is recommended for troubleshooting.

## Method 1

1. Set the Link Mode to Standard on both media converters. Leave all other switches in the Up position.
2. Connect the copper device to the copper port on the media converter. The LKC LED light indicates good copper connection. If the LKC LED is not lit, check the copper cable and the attached device.
3. Repeat for the far end media converter.
4. Connect the fiber cable to both media converters. The LKF LED indicates good fiber connection. If no LKF LED, check the fiber cabling. Ensure the transmitter and receiver pairs are crossed.
5. Return the units to the desired configuration. Connect the power source to the Media converter.

## Method 2:

The fiber connection can also be verified by configuring the remote media converter for loopback mode. The LKF LEDs on both media converters should be lit. Data should pass through the local converter, over the fiber connection to the remote media converter. At the remote media converter, the data will be looped back and passed through the fiber, back to the local converter and passed to the copper link.

## *Technical Specifications*

**Power Input / Consumption:** 6-16V DC / 2.6 W at 12VDC

**Operating Temperature:** -40°C to 75°C (-40°F to 167°F)

**Storage Temperature:** -40°C to 85°C (-40°F to 185°F)

**Operating Humidity:** 5% to 90% non-condensing

**Storage Humidity:** 5% to 95% non-condensing

**Operating Altitude:** Up to 3,048 m (10,000 ft)

**Dimensions:** 150 mm by 95 mm by 26 mm

**MTBF SC/ST Models:** 489,616hours

**MTBF SFP Models:** 584,216hours

### Fiber Optic Specifications:

Model	Mode	Wavelength (nm)	TX Power (dB)	RX Power (dB)	Budget
S-1110-M2xx05-XT	MM	TX: 850 RX: 850t.	Min: -9.5 Max: -4	Min: -17 Max: -3	7.5
S-1110-S2xx10-XT	SM	TX: 1310 RX: 1310.	Min: -9.5 Max: -3	Min: -20 Max: -3	10.5
S-1110-S1SC10U-XT	SM	TX: 1310 RX: 1490	Min: -9 Max: -3	Min: -20 Max: -3	11
S-1110-S1SC10D-XT	SM	TX: 1490 RX: 1310	Min: -9 Max: 3	Min: -20 Max: -3	11
S-1110-SFP-XT	SFP	<b>Note 1</b>			

**Note 1:** Fiber characteristics will depend on the SFP fiber module selected.

It is recommended the SFP fiber modules used with this product are rated for ambient temperature -40°C to 85°C (-4 0°F to 185°F)

### Fiber Cabling Requirements:

**MM:** 50/125 microns or 62.5/125 microns

**SM:** 9/125 microns

### Ethernet Copper Cabling Requirements:

- Category 5 UTP or STP
- 24-22 AWG
- Straight through or Ethernet crossover

**Note:** Please refer the product page on the Perle website for the most up to date models and specifications:

<http://www.perle.com/>

# ***Compliance Information***

## **FCC**

This product has been found to comply with the limits for a Class A digital device, pursuant to Part 15 of the FCC rules. These limits are designed to provide reasonable protection against harmful interference when the equipment is operated in a commercial environment. This equipment generates, uses, and can radiate radio frequency energy and, if not installed and used in accordance with the instructions in this Guide, may cause harmful interference to radio communications. Operation of this equipment in a residential area is likely to cause harmful interference, in which case the user will be required to correct the interference at his/her own expense.

## **EN 55022, Class A**

**WARNING** This is a Class A product. In a domestic environment this product may cause radio interference in which case the user may be required to take adequate measures.

## **EN 55024, Class A**

## **Laser Safety – IEC 60825-1:2007**

This product meets Class I Laser safety requirements per IEC-60825-1:2007 standard and complies with FDA/CDRH 21 CFR1040.10 and 21CFR1040.11.

**WARNING:** Visible and invisible laser radiation may be present when cables are not connected. Do not stare into the beam or view the beam directly with optical instruments. Failure to observe this warning could result in an eye injury or blindness.

**WARNING:** Use of controls, adjustments or the performance of procedures other than those specified herein may result in hazardous radiation exposure.

## ***Warranty / Registration***

Perle's standard Lifetime Warranty provides customers with return to factory repairs for Perle products that fail under the conditions of the warranty coverage. Details can be found at:

[http://www.perle.com/support\\_services/warranty.shtml](http://www.perle.com/support_services/warranty.shtml)

## **Contacting Technical Support**

Perle Technical Assistance Center (PTAC) at the link:

[www.perle.com/support\\_services/support\\_request.shtml](http://www.perle.com/support_services/support_request.shtml)

## **Copyright**

© 2012 Perle Systems Limited

All rights reserved. No part of this document may be reproduced or used in any form without written permission from Perle Systems.