

### ATC6DM

#### 6.5" 2-Way In-Ceiling Speakers

Congratulations on your purchase of the Phoenix Gold Innovative Home ATC Dual Mono (DM) In-Ceiling Speaker System. This product is designed to reproduce the audio portion of your home entertainment environment with accuracy and detail that will satisfy the most discriminating listener.

Please read this Installation Manual to ensure the proper installation and performance of your ATC Series speakers.

#### Preparing for your Installation

Gather the necessary tools for your installation.

You will need the following tools:

- 1) A Keyhole or Drywall Saw
- 2) A Phillips Screwdriver
- 3) Masking Tape
- 4) A Pencil
- 5) A Tape Measure
- 6) A Stud Finder (recommended)
- 7) Your ATC-DM speaker

#### ATC-DM Summed Mono Speaker Operation

The ATC-DM speaker is designed for use in areas where even distribution of sound is desired but stereo imaging is not practical because of space limitations, such as a bathroom or long hallway.

With a dual voice coil woofer and dual tweeters, the ATC-DM speaker can sum stereo amplifier channels into a mono audio signal. Two pairs of input terminals allow connection of both channels from a stereo amplifier to a single ATC-DM speaker. Set the switch on the back of the ATC-DM speaker to 16Ω for summed mono operation.

**Caution!** Amplifier damage will occur if the ATC-DM is set to 8Ω with two amplifier channels connected!

#### ATC-DM Conventional Speaker Operation

An ATC-DM speaker can be used to reproduce a single channel of audio by making connection to either set of input terminals and setting the switch on the back of the speaker to 8Ω. In this configuration, both woofer voice coils and both tweeters are driven in parallel by the connected amplifier channel.

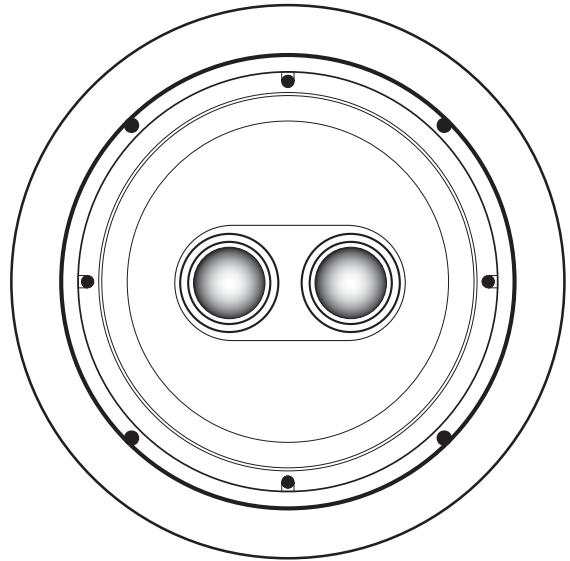

#### Placement

Plan your speaker placement carefully. Make certain that electrical, plumbing and any other services will not interfere within the ceiling where you plan to install your speakers. The ATC-DM speaker can be mounted in walls, but are typically used in ceilings. The speaker should be located so that it provides even coverage at your listening position.

#### New Construction

If you are installing your speakers in new construction before the finished walls go up, Phoenix Gold Innovative Home offers New Construction Brackets, which provide a stable frame that can be fastened to the wall studs or ceiling joists on 16" or 24" centers. This allows the sheet rock or other surface covering to be installed and provides a template to cut the opening for the ATC-DM speaker.

#### Existing Construction

In most modern buildings ceiling joists are positioned on 16" centers, providing a space between the joists of approximately 14 3/8". The specifications chart shows the appropriate cut out sizes (p. 4). Additionally, you should allow an extra 3/4" in all directions behind the ceiling surface to allow room for the screw clamps that mount the speaker to the ceiling to swing into position.

Use a stud finder to locate the joists behind the ceiling surface. Also, you should now check for obstructions like cross bracing in front of and behind the desired speaker location.

After selecting the mounting location, mark the hole to be cut out. A template is provided in the speaker box. Locate and align the template, then mark with pencil on the ceiling surface. If you are unsure whether there are obstructions behind the ceiling surface where the speakers are to be mounted, cut a small hole in the center of your marked mounting location. Holding your drywall saw at a 45 degree angle (See Figure 1), cut a square hole that you can use to locate any obstructions, should they exist.

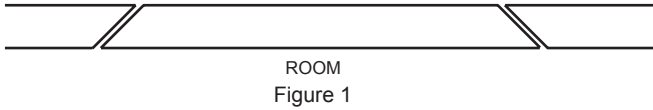

The 45 degree wedge shape of the removed surfacing material will make replacement, if necessary, a much easier task and yield a better finish when patching the work.

Once it has been determined that there are no obstructions, cut the hole to mount the speaker using the drywall saw at a 90 degree angle to the ceiling surface. Cover the raw edges of the wallboard with masking tape (See Figure 2). This will prevent the back pressure of the speaker from blowing loose gypsum dust out and onto the painted ceiling surface after installation. Do not allow the tape to extend more than 1/4" beyond the edge of the hole into the room. The frame of the speaker will cover and hide the tape.

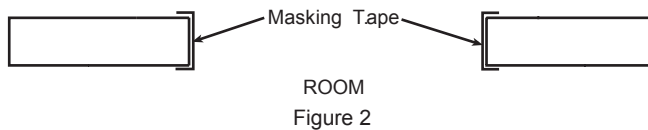

Next run your speaker wire to your speaker locations. A *UL rated CL3* speaker wire is recommended when running wire inside your walls. In many areas it may be required by code. When running your speaker wire you should avoid having the speaker wire run parallel to the 120V power lines to avert picking up hum and interference from the power service. If the speaker wire needs to cross a 120V power line at a right angle this is acceptable and will not create a problem.

If you are uncomfortable with running the speaker wire yourself in existing construction, it is recommended that you retain a qualified custom home installation specialist or electrician.

## Installing the Speaker

**Installation Tip!** To further enhance the performance of your ATC-DM speaker, the ceiling joist cavity where you plan to place your speaker can be stuffed with a generous quantity of fiberglass insulation. Stuff the area in front of and behind the speaker opening with 6" thick insulation to a depth of approximately 2 feet beginning 1 foot in front and 1 foot behind the speaker opening. If the insulation is foil or paper backed, face the backing away from the ATC-DM speaker. The addition of this insulation will help prevent unwanted transfer of sound into the otherwise large and resonant cavity of the un-insulated ceiling.

## Grill Removal for Installation

**CAUTION!** The grill is held in place by contact pressure around the edges where it attaches to the speaker frame. To avoid difficulty reinstalling the grill, care should be taken to not distort its shape while removing it.

While looking at the rear of the speaker assembly, rotate two of the adjacent mounting clamps outward and then evenly press them towards the grill. The clamp screws contact the inner surface of the grill, pushing it gently out of its mounting groove (Figure 3). Only lift the grill 1/4" (6mm) at this location. Next use the other mounting clamps to further loosen the grill. Use care to not distort the grill shape.

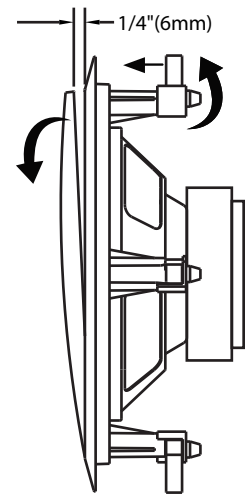

Figure 3

## Connecting the Speaker

It is now time to connect the speaker wire to the speaker. Your speaker wire is usually coded to identify each conductor as either positive or negative. This can be by color coding, or one conductor may have a printed marking or at least a rib along one edge that you will not find on the other. Identify which type of polarity coding that your wire is using. You must carefully observe that the positive terminal of the speaker output on your amplifier is connected to the positive terminal of the ATC-DM speaker. Likewise, the negative terminal of the amplifier's speaker output should be connected to the negative terminal of the ATC-DM speaker (Figure 4).

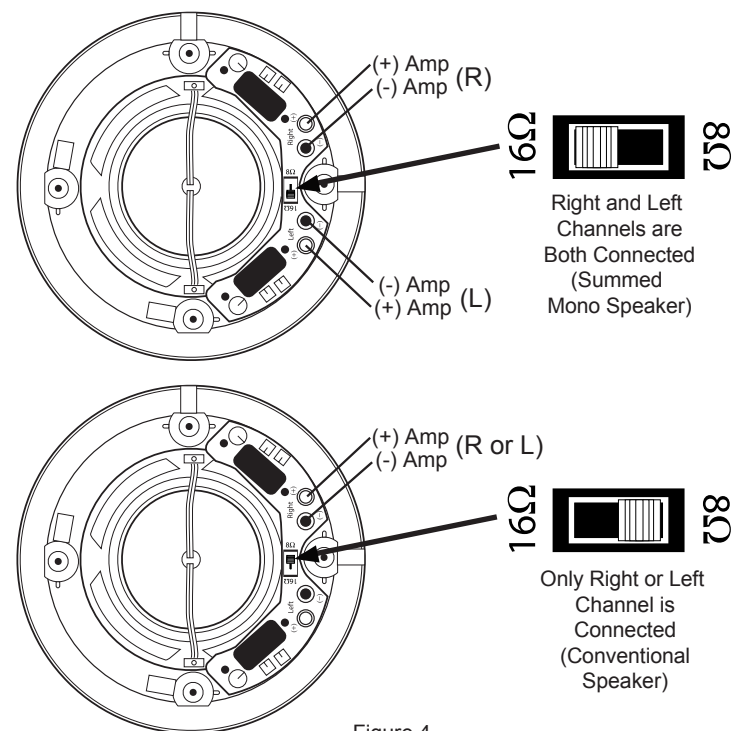
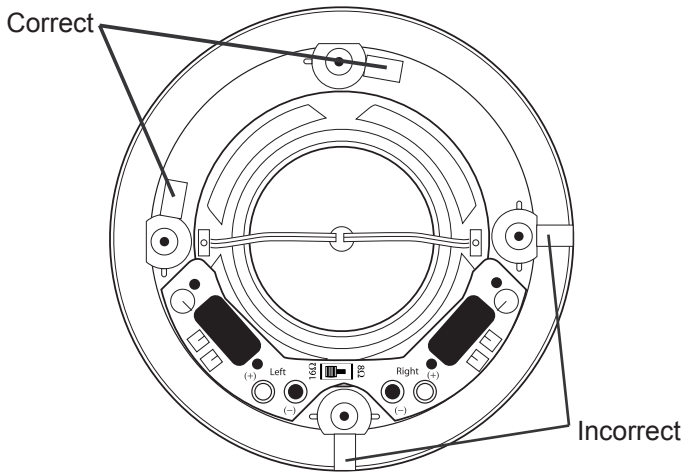

Figure 4

**Caution!** If the ATC-DM is set to 8Ω with two amplifier channels connected, amplifier damage will occur.

Next make sure that the clamps are positioned inside the frame of the speaker.



With the grill removed, place the speaker in the ceiling opening. Make sure that the speaker wire is not hanging against the speaker where it can vibrate and rattle as the speaker reproduces your audio program.

Next, one at a time, turn each of the four screws that operate the clamps counter clockwise a few turns until you feel the clamp is loose from its resting position. Now turn the screw clockwise until you feel the clamp contact the ceiling surface.

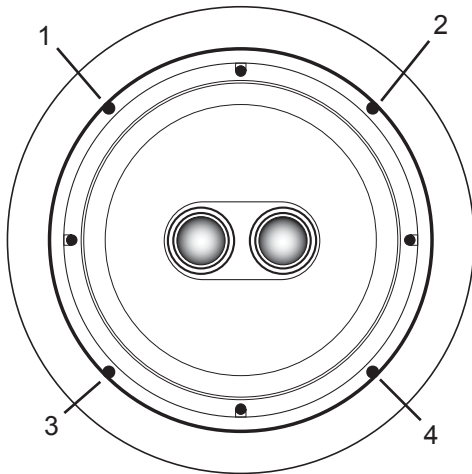

Tighten all four of the mounting screws in the same manner until the speaker is properly aligned and held tight to the ceiling surface. **Caution: Do not over tighten!**

### Painting the Speaker

A paint shield is included in each ATC-DM speaker package. Place the paint shield inside the frame to protect the speaker. You can now safely paint the speaker frame to match your wall surface if you desire.

When painting the grill caution should be taken to ensure that paint does not clog or congest the perforated openings in the grill. This would prevent proper operation of the grill by restricting the airflow from the individual drivers in the speaker.

### Removing the ATC Series Speaker

Should it ever become necessary to remove the ATC Series speaker from the ceiling, simply remove the grill and turn the four mounting screws counter-clockwise until you feel the clamps lock out of position in their resting flange. The speaker should easily come out of the wall for service or replacement.

### Grill Removal (if installed)

Locate a small hook tool (available at most auto parts stores or home improvement shops, resembling a dentist's pick- a bent paper clip or stiff wire will work as well), hook the metal mesh of the grill near a corner or edge and gently pull it towards you. Only lift the grill 1/4" (6mm) at this location. Move the tool 1-2" (25-50mm) and repeat until the grill can be removed without damaging it (Figure 5).

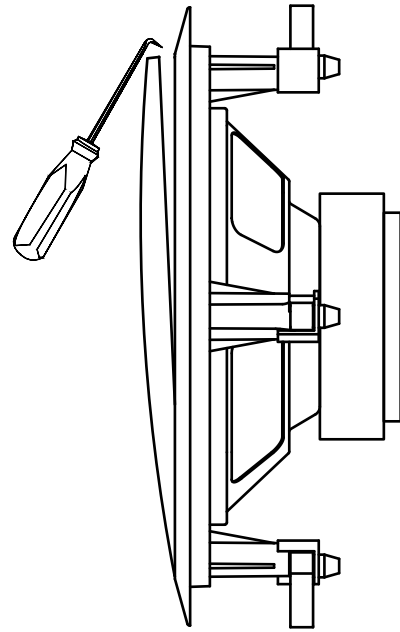

Figure 5

### Recommended Speaker Wire Gauges

The resistance of the speaker wire in your installation can cause your speakers to perform at less than their optimum quality level. Excess resistance caused by using an undersized speaker wire can result in loss of detail and definition in the bass region of your audio program, as well as loss of dynamic range. Over extremely long wire runs you may even experience a loss of high frequency content in the audio signal.

To prevent sonic degradation in your ATC Series speaker installation, total speaker wire resistance should be kept below 0.5 ohms. The following table lists recommended speaker wire gauge versus wire run length.

50' or less	- 16 Gauge 2-Cond. CL3 Rated
50' - 150'	- 12 Gauge 2-Cond. CL3 Rated
150' - 200'	- 10 Gauge 2-Cond. CL3 Rated

# ATC6DM

## Specifications

Dual Voice Coil Woofer	6.5" Mica Filled Poly Cone with Butyl Rubber Surround
Tweeters	Dual 19mm ferrofluid Cooled
Frequency Response	50Hz to 20kHz
Impedance	16 ohms (mono application) / 8 ohms (stereo application)
Sensitivity	86dB/89dB, 2.83v @ 1m
Power Capacity	10 to 175 Watts
Outer Dimension	9" (229mm) diameter
Cut Out Dimension	7.75" (197mm) diameter
Mounting depth	3.38" (86mm)
New Construction Bracket	Order Part Number: NCBC6

---

### Two Year Limited Warranty

Phoenix Gold Innovative Home, a division of Peak Audio Group, warrants this product against defects in materials and workmanship for a limited period of time. For a period of two (2) years from date of original purchase, we will repair or replace the product, at our option, without charge for parts. Customer must pay for all labor charges associated with the removal and re-installation of speakers for the limited period and all parts and labor charges after the limited warranty period expires. The limited warranty period for factory refurbished products expires after ninety (90) days from date of original purchase. This limited warranty applies only to purchases from authorized Phoenix Gold Innovative Home Retailers or Distributors. This limited warranty is extended only to the original purchaser and is valid only to consumers in the United States.

Consumers are required to provide a copy of the original sales invoice from an authorized Phoenix Gold Innovative Home Retailer or Distributor when making a claim against this limited warranty. This limited warranty only covers failures due to defects in materials or workmanship that occur during normal use. It does not cover failures resulting from accident, fire, flood, misuse, abuse, neglect, mishandling, misapplication, alteration, faulty installation, modification, service by anyone other than Phoenix Gold Innovative Home, or damage that is attributable to Acts of God. It does not cover costs of transportation to Phoenix Gold Innovative Home or damage in transit. The customer should return their defective product, freight prepaid and insured, to Phoenix Gold Innovative Home only after receiving a Return Authorization.

Repair or replacement under the terms of this warranty does not extend the term of this warranty. Should a product prove to be defective in workmanship or material, the consumer's sole remedies will be repair or replacement as provided under the terms of this warranty. If the defective product is discontinued Phoenix Gold Innovative Home may replace the product with an equivalent or superior product at its option. Any cost of re-installation or repair of wall or ceiling surface is the sole responsibility of the customer and that cost shall not be the responsibility of Phoenix Gold Innovative Home. Under no circumstances shall Phoenix Gold Innovative Home be liable for loss or damage, direct, consequential or incidental, arising out of the use of or inability to use the product. There are no express warranties other than described above.

**PHOENIXGOLD®**  
INNOVATIVE HOME

13970 SW 72nd Avenue ■ Portland, Oregon 97223  
503.914.4688 ■ Fax: 503.746.5224 ■ Support: 877.715.5439  
www.audiosource.net ■ support@audiosource.net