

---

SPARC M10 Systems/  
SPARC Enterprise/  
PRIMEQUEST

---

COMMON INSTALLATION PLANNING  
MANUAL



## FOR SAFE OPERATION

### Handling of This Manual

This manual contains important information regarding the use and handling of this product. Read this manual thoroughly. Use the product according to the instructions and information available in this manual. Keep this manual in hand for further understanding.

Fujitsu makes every effort to prevent users and bystanders from being injured or from suffering from damages to their property. Use the product according to this manual.

## ABOUT THIS PRODUCT

This Product is designed, developed and manufactured as contemplated for general use, including without limitation, general office use, personal use and household use, but is not designed, developed and manufactured as contemplated for use accompanying fatal risks or dangers that, unless extremely high safety is secured, could lead directly to death, personal injury, severe physical damage or other loss (hereinafter "High Safety Required Use"), including without limitation, nuclear power core control, airplane control, air traffic control, mass transport operation control, life support, weapon launching control. You shall not use this Product without securing the sufficient safety required for the High Safety Required Use. If you wish to use this Product for High Safety Required Use, please consult with sales representatives in charge before such use.

## RADIO FREQUENCY INTERFERENCE STATEMENT

### The following notice is for EU users only.

**WARNING:** This is a product which meets Class A of EN55022. In a domestic environment this product may cause radio interference in which case the user may be required to take adequate measures.

### The following notice is for USA users only.

This equipment has been tested and found to comply with the limits for a Class A digital device, pursuant to Part 15 of the FCC Rules. These limits are designed to provide reasonable protection against harmful interference when the equipment is operated in a commercial environment. This equipment generates, uses, and can radiate radio frequency energy and, if not installed and used in accordance with the instruction manual, may cause harmful interference to radio communications. Operation of this equipment in a residential area is likely to cause harmful interference in which case the user will be required to correct the interference at his own expense.

## **TRADEMARKS ACKNOWLEDGEMENTS**

- UNIX is a registered trademark of The Open Group in the United States and other countries.

The contents of this manual shall not be disclosed in any way or reproduced in any media without the express written permission of Fujitsu Limited.

All Rights Reserved, Copyright © FUJITSU LIMITED 2002-2011

## Revision History

(1/1)

Edition	Date	Revised section (Added/Deleted/Altered)	Details
01	2002-10-31	—	—
02	2005-09-15	Entire manual (Altered)  Section 3.3.2 (Altered/Added)  Section 5.2.2 (Added)	<ul style="list-style-type: none"> <li>• Technical brush-up</li> <li>• Modification of the manual title</li> <li>• Addition of PRIMEQUEST</li> <li>• Modification of the concept of units operational grouping</li> <li>• Addition of description for concentration of small equipment</li> <li>• Addition of conditions for using mobile phones</li> </ul>
03	2008-04-16	Entire manual (Altered)	<ul style="list-style-type: none"> <li>• Modification of manual title</li> <li>• Addition of description for SPARC Enterprise</li> <li>• Deletion of description for PRIMEPOWER</li> </ul>
04	2009-12-15	Section 4.3.5 (Altered)	<ul style="list-style-type: none"> <li>• Modification of tolerable limit of Hydrogen sulfide gas</li> </ul>
05	2011-11-25	Entire manual (Altered)  Section 2.2.1 (Altered)  Section 4.3.5 (Altered)  Section 4.3.6 (Added)  Section 8.2.2 (Added)  Reader's Comment Form (Altered)	<ul style="list-style-type: none"> <li>• Technical brush-up</li> <li>• Modification of the value for vibrations during earthquakes</li> <li>• Modification of Table 4.4</li> <li>• Addition of the seawater (salt damage)</li> <li>• Modification of the value for withstanding a horizontal seismic intensity</li> <li>• Addition of consulting department of an earthquake preparedness</li> <li>• Modification of the address for sending back of the form</li> </ul>

Note: In this table, revised section is indicated by its section number in the current edition.

An asterisk (\*) indicates a section in the old edition.



# Preface

This manual describes the requirements and concepts of installation and facility planning that pertain to the setup of SPARC Enterprise and PRIMEQUEST. Installation and facility planning requires full review with Fujitsu representatives in charge according to the instructions presented herein.

This manual is intended for site planners preparing for the server system installation. Use this manual to review server system installation plans or to run and administer the server system. The reader is assumed to have some knowledge or experience in the server system installation planning.

## Contents and Organization of This Manual

This manual consists of 8 chapters, one appendix, one acronyms and abbreviations section, and one index as below:

The manual contains general information and precautions required for the server system installation plans. For information about specific SPARC Enterprise models and PRIMEQUEST models, refer to the respective Installation Planning Manual.

### CHAPTER 1 Installation Planning Overview

This chapter describes general requirements for the server system installation planning and for the facilities used to house the server systems.

### CHAPTER 2 Installation Sites

This chapter describes the recommended sites and structures and the buildings in which the server systems can be installed, and the structures of the computer rooms.

### CHAPTER 3 Equipment Layout

This chapter describes the procedures and precautions to take in laying out the server system equipment.

### CHAPTER 4 Air Conditioning

This chapter describes the available computer room air conditioning methods, along with their features, conditions of air conditioning, and precautions.

### CHAPTER 5 Electromagnetic Environment and Static Electricity

This chapter describes the electromagnetic environmental conditions relevant to server systems, and electrostatic effects.

## CHAPTER 6 Power Supply Facilities

This chapter describes the power supply requirements, power supply facilities, grounding plans, power distribution boards, and power distribution routes for the server systems.

## CHAPTER 7 Protection Against Lightning

This chapter describes the safeguards necessary to protect server systems against destructive lightning surge voltages.

## CHAPTER 8 Security Actions

This chapter describes the actions necessary to ensure server system security.

## Appendix A Conversion Information

This appendix provides quick reference tables for measure units conversion and fractional decimal equivalent conversions.

## Acronyms & Abbreviations

This acronyms and abbreviations provides complete word(s) of acronyms and abbreviations used in this manual.

## Index

This index provides the keywords, along with the reference page numbers so that users can find the necessary information at a glance.



## Other Reference Manuals

When installing the SPARC Enterprise or PRIMEQUEST, read the installation guide for each model first.

## For the readers

- If you find any inconvenience with the description or incorrect explanation in this manual, please fill in the "Comment Form" sheet at the back of this manual and forward it to the address described on the sheet.
- This manual is subject to be revised without prior notice.



# Contents

.....	1
Preface .....	i
<b>CHAPTER 1 Installation Planning Overview</b> .....	<b>1</b>
1.1 Office Installation and Computer Room Installation .....	1
1.1.1 Office installation .....	1
1.1.2 Computer room installation .....	2
1.2 Computer Room Installation Planning .....	3
1.2.1 Device support planning .....	3
1.2.2 Support staff assignment .....	3
1.3 Preparing Building and Facilities .....	4
1.3.1 Building and facilities needed to install a server system .....	4
1.3.2 Furnishings accompanying a server system .....	4
1.3.3 Rooms needed to run the server system .....	5
1.4 Scheduling .....	5
<b>CHAPTER 2 Installation Sites</b> .....	<b>7</b>
2.1 Building Location .....	7
2.1.1 Sites convenient for systems development and administration .....	7
2.1.2 Utility services .....	8
2.1.3 Secure sites .....	8
2.2 Buildings .....	8
2.2.1 Building structures .....	9
2.2.2 Computer room location .....	12
2.2.3 Spaces .....	12
2.2.4 Facilities .....	13
2.2.5 Access routes .....	14
2.2.6 Water and fuel stocks .....	16
2.3 Computer Room Structure .....	16
2.3.1 Computer room structural requirements .....	16
2.3.2 Free-access flooring .....	18
2.3.3 Interiors .....	22
<b>CHAPTER 3 Equipment Layout</b> .....	<b>25</b>
3.1 Proposed Computer Room Top View .....	25
3.2 Equipment Templates .....	25
3.3 Precautions in Preparation of an Equipment Layout .....	26

3.3.1	Hardware constraints	26
3.3.2	Operational considerations	26
3.4	Air Conditioners	29
3.4.1	Air conditioning units	29
3.4.2	Air conditioning piping	29
3.4.3	Heat distribution	29
3.4.4	Air circulation	29
3.4.5	Dusting	30
3.5	Power Supply Facilities	30
3.5.1	Power supply facilities for server system	30
3.5.2	Power supply facilities for air conditioners	31
3.5.3	Facility control panels	31
3.6	Line and Signal Wiring Facilities	32
3.6.1	Line facilities	32
3.6.2	Signal wiring facilities	32
<b>CHAPTER 4 Air Conditioning</b>		<b>33</b>
4.1	Characteristics of Computer Room Air Conditioning	33
4.1.1	Constant temperatures and humidities	33
4.1.2	Air conditioning conditions and capacities	34
4.1.3	Service time and reliability	34
4.2	Styles of Air Conditioner	34
4.2.1	Direct blowing	35
4.2.2	Duct blowing	35
4.2.3	Underfloor ventilation	36
4.2.4	Combined use of direct or duct blowing and underfloor ventilation	37
4.3	Air Conditioning Conditions	38
4.3.1	Permissible temperature and humidity ranges for server systems	38
4.3.2	Recommended temperatures and humidities for computer rooms	39
4.3.3	Temperature and humidity recommendations for computer rooms	40
4.3.4	Dust	43
4.3.5	Corrosive gases	43
4.3.6	Seawater (salt damage)	44
4.4	Thermal Load and Cooling Capacities	45
4.4.1	Thermal load imposed on air conditioner	45
4.4.2	Example of cooling capacity calculations for room air conditioning	46
4.4.3	Underfloor ventilation air conditioning	49
4.4.4	Convenient formulas for air conditioning capacities	50
4.5	Precautions Pertaining to the Installation of Air Conditioners	52
4.5.1	Humidifier	52
4.5.2	Air conditioner filters	53

---

4.5.3	Installing temperature/humidity sensors	54
4.5.4	Taking in fresh air	54
4.5.5	Preventing dew condensation in underfloor ventilation	55
4.5.6	Preventing water leaks and installing detectors	56
4.5.7	Installing a backup unit	57
4.5.8	Preventing freezing of cooling water	57
<b>CHAPTER 5 Electromagnetic Environment and Static Electricity</b>		<b>59</b>
5.1	Magnetic Fields	59
5.1.1	Allowable magnetic field intensities of displays	59
5.1.2	Sources of magnetic fields and fault symptoms	60
5.1.3	Magnetic field control	61
5.2	Electric Fields	62
5.2.1	Allowable electric field intensities for server systems	62
5.2.2	Conditions for using mobile phones	62
5.3	Static Electricity	63
5.3.1	Recommended electrostatic voltage for a computer room	63
5.3.2	Electrostatic control in the computer room	63
<b>CHAPTER 6 Power Supply Facilities</b>		<b>65</b>
6.1	Input Power Requirements	65
6.1.1	Input power requirements	65
6.1.2	Calculating the power required	66
6.1.3	Calculating the rush current	66
6.2	Power Supply Facilities	67
6.2.1	Kinds and uses of power supply facilities	67
6.2.2	Selecting power supply facilities	69
6.3	UPS Requirements	72
6.4	Grounding	76
6.4.1	Grounding equipment in the computer room	77
6.4.2	Grounding other equipment	79
6.4.3	Grounding LAN devices	80
6.4.4	Grounding-plate method	81
6.5	Distribution Panels	83
6.5.1	Distribution panel location	83
6.5.2	Distribution panel breakers	83
6.5.3	Distribution panel structure	84
6.6	Distribution Lines	87
6.6.1	Induced noise control	87
6.7	Share of Responsibility for Construction in a Computer Room	88
6.8	Distribution Line Insulation Testing	89

6.8.1	Test voltage .....	89
6.8.2	Phase and grounding cable insulation test .....	89
6.8.3	Interphase insulation testing .....	89
<b>CHAPTER 7 Protection Against Lightning .....</b>		<b>91</b>
7.1	Protection of AC Line .....	92
7.2	Protection of Signal Lines .....	94
<b>CHAPTER 8 Security Actions .....</b>		<b>95</b>
8.1	Basic Concepts .....	95
8.1.1	Levels of security .....	95
8.1.2	Objects of security .....	96
8.1.3	Kinds of disasters .....	97
8.2	Details .....	97
8.2.1	Fire .....	97
8.2.2	Earthquakes .....	101
8.2.3	Water damage .....	102
8.2.4	Burglary .....	104
8.2.5	Rat damage .....	105
8.3	Maintenance and Management of Disaster Control Facilities .....	106
<b>Appendix A Conversion Information .....</b>		<b>107</b>
A.1	Units of Measure Conversion .....	107
A.2	Fraction to Decimal Equivalence .....	108
<b>Acronyms &amp; Abbreviations .....</b>		<b>109</b>
<b>Index .....</b>		<b>111</b>

---

## Figures

Figure 2.1	Slit floor panel .....	20
Figure 2.2	Floor panels with an airflow control damper .....	21
Figure 2.3	Air flow control panel .....	21
Figure 3.1	Concept of units operational grouping .....	27
Figure 4.1	Direct blowing setup .....	35
Figure 4.2	Duct blowing setup .....	36
Figure 4.3	Underfloor ventilation setup .....	37
Figure 4.4	Schematic view of a combined system .....	38
Figure 4.5	Psychrometric chart applicable to changing the room temperature	41
Figure 4.6	Psychrometric chart applicable to lowering the underfloor temperature .....	42
Figure 4.7	Typical air conditioner characteristics .....	46
Figure 4.8	Air condition in a psychrometric chart (for a typical air conditioner)	46
Figure 4.9	Air condition in a psychrometric chart (underfloor-ventilation air) ..	49
Figure 4.10	Dike .....	56
Figure 6.1	System based on a UPS .....	69
Figure 6.2	System based on a UPS and an independent power generator ...	69
Figure 6.3	Commutating load circuit .....	73
Figure 6.4	Method of grounding equipment .....	77
Figure 6.5	Typical 100 Base-T connection .....	81
Figure 6.6	Grounding-plate method .....	82
Figure 6.7	Distribution panel (free-standing) .....	84
Figure 6.8	Distribution panel (wall-mounted) .....	84
Figure 6.9	Round crimp terminal dimensions .....	86
Figure 6.10	Space around output terminal boards .....	86
Figure 6.11	Grounding connections within a distribution panel .....	87
Figure 6.12	Share of responsibility for construction in a computer room .....	88
Figure 7.1	Surge absorber (power outlet connected type) .....	93
Figure 7.2	Install surge absorber on the distribution panel's input side .....	93
Figure 7.3	Lighting control action when using external modem .....	94
Figure 7.4	Lightning control action for LAN cables .....	94
Figure 8.1	Designating alarm zones .....	98





## Tables

Table 2.1	Ceiling heights.....	17
Table 2.2	Raised floor heights of free-access floors.....	18
Table 2.3	Strengths and surface materials of free-access floor panels.....	19
Table 3.1	Kinds, uses, and locations of power supply facilities.....	30
Table 4.1	Recommended temperatures and humidities for computer rooms.....	40
Table 4.2	Temperature and humidity recommendations (changing the room temperature).....	41
Table 4.3	Temperature and humidity recommendations (lowering the underfloor temperature).....	42
Table 4.4	Tolerable limits for corrosive gases.....	43
Table 4.5	Sources of overload and amount of heat dissipation.....	45
Table 4.6	Examples of typical air conditioner cooling capacity calculations.....	47
Table 4.7	Examples of underfloor-ventilation air conditioner cooling capacity calculations.....	49
Table 4.8	Convenient formulas for air conditioner capacity.....	50
Table 5.1	Sources of magnetic fields and fault symptoms.....	60
Table 6.1	Input power requirement.....	66
Table 6.2	Types of available power supply facilities and usage.....	67
Table 6.3	Transformers for 200 V server systems.....	70
Table 6.4	Transformers dedicated to 400 V server systems.....	71
Table 6.5	Specification of the grounding trunk cable for server systems (in the buildings complying to the IEC standards).....	78
Table 6.6	Requirements for other equipment grounding facilities.....	79
Table 6.7	Details of the separation of the LAN transmission line signal ground (SG).....	80
Table 6.8	Output terminal board dimensions.....	85
Table 7.1	Specification of power control box (F9710PW2).....	92
Table 7.2	Recommended surge absorber for external modem.....	94
Table 8.1	Characteristics of fire extinguishing agents.....	99
Table A.1	Units-of-measure conversion.....	107
Table A.2	Fractions to decimal-equivalent conversion.....	108



# CHAPTER 1 Installation Planning Overview

This chapter defines the general requirements for server system installation planning and for the facilities used to house server systems. Successful planning ensures system installation efficiency now and in the future, assuring system reliability, convenience, and functionality.

The users wishing to install a server system must make both the site and associated facilities available, and also develop meticulous installation plans to ensure that all of the facilities prerequisite to operating the server system into service are ready before equipment are delivered to the site.

## 1.1 Office Installation and Computer Room Installation

Installation site of server system can be classified into two types as described below. The decision of installation site depends on the unit size and specific conditions of use.

- Office installation
- Computer room installation

The following are overview of each case:

### 1.1.1 Office installation

Computer equipment appropriate for office space installation is:

- Compact server units
- I/O devices

These equipments are more appropriate for office space installation than are equipment that must be installed in a computer room, because they make less noise, have lower power requirements, dissipate less heat and are operable over wider temperature and humidity ranges. Office installation does not require free-access floors or special electrical facilities. As a rule, the building's existing air conditioning system can be shared.

A server system involving equipment that is too large to fit into the available office space or a mixture of equipment having a combined heat dissipation over about 21 MJ/h (20000 Btu/h) would need to be installed in facilities meeting the computer room installation requirements.

### **(1) Equipment suitable for office installation**

Equipment meeting any of the following requirements is suitable for office installation.

- Equipment that operates from a power supply of single-phase, and that can be plugged in
- Equipment whose noise level is low enough to permit installation in a general office environment  
(Equipment with a height of 1 m or lower: Noise level of 47 dB (A) or less; equipment with a height of 1 m or higher: Noise level of 50 dB (A) or less)
- Equipment with permissible ranges of temperature and humidity that meet installation requirements in a general office environment  
(Indoor temperature: 5 to 35°C; indoor humidity: 20 to 80% RH (operating) or 8 to 80% RH (not operating))

### **(2) Air conditioning and power requirements of equipment subject to office installation, and associated facilities**

The amount of heat dissipated by equipment subject to installation in an office, the power requirements, and the number of equipment items installed may require improvements to the air conditioning and power supply facilities in the office in question. In installing equipment in an office space, it is important to review beforehand the air conditioning facilities of the office and the ratings of the power supplies available.

#### **1.1.2 Computer room installation**

Computer equipment appropriate for computer room installation is:

- A server system involving equipment that is too large to fit into the office space
- A mixture of equipment having combined heat dissipation over about 21 MJ/h (20000 Btu/h)

## 1.2 Computer Room Installation Planning

Computer room installation requires prior device support planning and support staff assignment.

### 1.2.1 Device support planning

Regarding the method of supporting device, the following items must be planned:

#### (1) Configuration of the server system and equipment to be added

- Environmental specifications for each room (such as dimensions, mass, voltages, power requirements, heat dissipation, and temperature and humidity conditions)
- Scale templates for planning device layouts
- Kinds, numbers, and length limitations of signal cables used to connect devices installed between rooms

#### (2) Quantities of storage media to be stored

CD, DVD, MO, magnetic tapes, floppy disks, printed forms, etc.

#### (3) Quantities of supplies and consumables to be stored

Print forms, ink ribbons, toner, photo-conductive drums, etc.

#### (4) Quantities of spare parts and maintenance tools to be stored

#### (5) Storage space for user's manuals

#### (6) Staff and visitor access management scheme

#### (7) Policy on carrying media and supplies in and out of the computer room

### 1.2.2 Support staff assignment

To proceed the installation planning smoothly, an installation planning group comprises the appointed staff of the user organization and Fujitsu is needed to be organized.

Regarding the required staff in the installation planning group, consider the following:

- An installation planning group and a supervisor within the user organization
- An installation consultant from a Fujitsu or agent

## **1.3 Preparing Building and Facilities**

Review the building and facilities needed to install a server system, ancillary furnishings accompanying the server system, and the rooms needed to run the server system.

### **1.3.1 Building and facilities needed to install a server system**

Regarding the building and facilities needed to install a server system, consider the following:

- Building
- Power supplies
- Air conditioning
- Signal line, telecommunication facilities
- Fire extinguishers, fire extinguishing facilities

### **1.3.2 Furnishings accompanying a server system**

Review the following furnishings accompanying in use of a server system:

- Cabinets and lockers
  - Small equipment
  - Storage media
  - Supplies
  - Spare parts and maintenance tools
  - Instructions manuals
- Warehouses
  - Storage media
- Trucks

### **1.3.3 Rooms needed to run the server system**

Regarding the rooms needed to run the server system, review the following:

- Offices
- Meeting rooms
- System administrator rooms
- System developer rooms
- Backup maintenance engineer and other related rooms

## **1.4 Scheduling**

In installing a server system in a computer room, the scheduling of the following activities is recommended:

- Development of an overall installation planning schedule
- Facility design verification
- Verification of the status of ongoing facility construction
- Final preparations for installing the server system, facility and interior finish checks, and, where appropriate, facility test runs





# CHAPTER 2 Installation Sites

This chapter details the recommended sites and structures and the buildings in which server systems can be installed, and the structures of the computer rooms.

Server systems setups can be classified into two broad forms: one in which a server system is installed in a computer room for message collection and distribution processing and perform calculation processing, and one in which a server system is installed conveniently in an office for use as a stand-alone machine or as one connected to a communications network.

This chapter presents a variety of tips and hints for determining the most appropriate locations for server systems. The importance of the individual tips and hints, however, depends on the intended use of the server system. Alternative or corrective actions may be available for particular items. The server system department of the user's organization is recommended to hold in-depth consultations on requirements for determining a server system's location with its department in charge of construction or with a building contractor.

## 2.1 Building Location

The building in which a server system is to be installed should be conveniently located for systems development and administration, afford good access to utility services, such as electricity, water, and telephone lines, and ensure security.

### 2.1.1 Sites convenient for systems development and administration

When selecting sites conveniently located for systems development and administration, take the following factors into consideration:

- Commutation of the management and employees
- Communication with the related departments
- Traffic to and from subcontractors

### 2.1.2 Utility services

When selecting sites that afford good access to utility services, take the following factors into consideration:

- Satisfactory availability of electric power
- No suspension or failure of water supplies, or the availability of alternate measures for water supply
- Access to telecommunication lines

### 2.1.3 Secure sites

When selecting sites that offer a high degree of security, take the following into consideration. (Among these factors, those that threaten security will be described later.) The adverse effects of these factors can be minimized if the structural requirements for buildings or computer rooms are met.

- Little occurrence of earthquakes, with the effects therefrom minimal
- No danger of damage from flooding and snow
- Little occurrence of lightning
- Easy implementation of fire preventive measures
- No high-level electromagnetic radiation influence
- Little presence of dust and corrosive gases
- Procedures in place for dealing with riots and trespassing, break-ins, etc.

## 2.2 Buildings

The buildings in which server systems can be installed are broadly classified into the following forms:

- Dedicated server system centers
- Office rooms converted to dedicated computer rooms
- General office rooms in which server systems are installed for convenience's sake

Except for the last form of installation mentioned above, server system centers and dedicated computer rooms would best benefit from structural safety considerations, because they are intended to house server systems handling large amounts of data.

Particularly, the more important a server system center is, the more strict safety considerations are required.

## 2.2.1 Building structures

Structural considerations for buildings in which server systems are to be installed are summarized below.

### (1) Floor strength

The floor of the building in which a server system is to be installed should be strong enough to withstand the combined weight of the server and its component devices. An equipment layout superimposed with weight distributions should be presented to the building designer or installation engineer as a means of determining whether the server system can be installed.

#### a) Base floor strength of the computer room

The base floor loading strength of the computer room including the strength of the floor itself, beams, and columns should be sufficient to accept the installation of a server system.

- Loading strength of the floor itself

The base floor of the computer room, like the floor of a general office room, must have a loading strength of  $2.9 \text{ kN/m}^2$  ( $61 \text{ lbf/ft}^2$ ) or greater.

- Loading strength of beam and column

A loading strength of  $2.9 \text{ kN/m}^2$  ( $61 \text{ lbf/ft}^2$ ) or greater is recommended for the beams and columns that support the floor of the computer room.

Although a loading strength of  $1.8 \text{ kN/m}^2$  ( $38 \text{ lbf/ft}^2$ ) or greater is recommended for the beams and columns used to support the floor of a general office room, this could restrict the equipment layout of large chained devices or heavy devices.

#### b) Verification by the building designer or the building constructor

Even if the base floor strength of the computer room meets the value suggested above, the structure of the building, its secular changes, or the location of the server system may not accept its installation. For these reasons, an equipment layout superimposed with weight distributions should be presented to the building designer or the building constructor as a means of determining whether the server system can be installed.

#### c) Rooms used to install heavy devices

Power supply rooms and media storage rooms may require reinforcement even when they provide a loading strength of  $2.9 \text{ kN/m}^2$  ( $61 \text{ lbf/ft}^2$ ).

**d) Newly constructed buildings**

If a server system is to be installed in a newly constructed building, it is recommended that loading strength of the floor itself, beam, and column is 4.9 kN/m<sup>2</sup> (100 lbf/ft<sup>2</sup>) or greater for such computer room.

**(2) Vibration and earthquake-proofing**

Recent years have witnessed the emergence of earthquake-free buildings mounted on earthquake-free foundations that absorb the effects of earthquakes and computer rooms with earthquake-free floors as safeguards against earthquakes. Because the higher floors in an ordinary building are more susceptible to the effects of earthquakes than the lower floors, it is recommended that server systems be installed on lower floors.

Regarding the floor on which the server system is to be setup, special consideration should be given to the following:

- As little vibration as possible in the steady state
- Vibrations during earthquakes not exceeding 2.5m/S<sup>2</sup> (8.2ft/S<sup>2</sup>)
- If vibrations during earthquakes exceed 2.5m/S<sup>2</sup> (8.2ft/S<sup>2</sup>), study the available safeguards against earthquakes. The safeguards against earthquakes include earthquake-free method, securing method, or clamping devices in position.

**(3) Water damage****a) Drainage**

The basement or the first floor of a building should be avoided as a site for installing a server system because these floors can be flooded during floods. If installing a server system on such floors is unavoidable, embankments or drainage facilities should be provided to ensure uninterrupted functionality of the server system.

**b) Structure**

The building in which a server system is installed must be so structured to protect the server system from the effects of the following:

- Damage from storms and flooding
- Fire fighting water
- Water leaking from the roof
- Water flowing from stairways
- Water leaking from water facilities in the upper floor(s)
- Water leaking from the water pipelines above the ceiling

- Water leaking due to clogged drainage pipelines on the roof or in the upper floor(s)

c) Preventing water leakage from air conditioning facilities

Because air conditioning facilities commonly involve the use of water, as in coolant pipelines, humidifying feed water, and water generated as a result of dehumidifying, they would require measures to prevent water leakage. These measures include:

- Embankments surrounding air conditioning facilities and detection of water leakage inside the embankments
- Detection of water leakage from water pipes

#### **(4) Fires**

a) Fireproofing

Buildings should be made fireproof.

b) Buffer zones

Buffer zones should be provided to avoid the effects of fires in the neighborhood.

c) Effects of fires in the neighborhood

Regarding the effects of smoke and heat caused by fires in the neighborhood, following circumstances must be reviewed:

- From the standpoint of security, computer rooms and media storage rooms should be windowless or have double walls to provide protection from fire, etc.
- The air intake duct in the computer room should be capable of being cut off immediately during outbreaks of fires.

#### **(5) Disasters caused by human neglect**

Things to consider with regard to disasters caused by human neglect are summarized below:

- Markings that clearly point to the presence of a server system should be avoided. Such signboards would include those attached to a building.
- Computer rooms should be at locations where access can be limited to only authorized personnel.
- Areas surrounding buildings housing server systems should be guarded by patrolling, for example.
- Rooftop facilities and ground facilities on the premises visible from outside the premises should be removed from view with screens or fences.
- Computer rooms should also not be visible externally.

## 2.2.2 Computer room location

Things to consider with regard to location of the computer room are summarized below.

### (1) Operability

The computer room should be conveniently located for access to communication with related departments and for data receipt, issue, and relocation.

### (2) Security

From a security standpoint, the computer room should be located on the lower middle floor of a building, rather than the top floor or a basement. The first floor facing the street should also be avoided. In addition, the top floor is not suitable since top floor would be influenced by the effects of heat from the rooftop and ambient-air temperatures.

### (3) Sunshine requirements

Computer rooms do not have any special sunshine requirements because they typically house a limited staff of operators and a large set of devices.

### (4) Power supply

Computer rooms installed in buildings should be so located to afford access to the required power source.

### (5) Air conditioning

Computer rooms installed in buildings should be so located to afford access to air conditioning.

## 2.2.3 Spaces

Regarding the spaces pertaining to buildings in which server systems are to be installed, the following items, among others, should be considered:

- The space in which the server system is to be installed
- The space through which the server system will be moved
- The space where additional peripheral equipment or other server systems will be installed

- 
- The space used for signal and telecommunication lines in the building
  - Recording media storage room
  - Office room needed for systems administration and development
  - Storage rooms for supplies and spare parts
  - Access control room

## 2.2.4 Facilities

Considerations pertaining to facilities are summarized below:

### (1) Power supply facilities

The power supply facilities should distribute enough power to meet the requirements of the server systems and associated facilities. A dedicated transformer or uninterruptible power supply is required as a power supply facility for the server systems.

When the computer room is selected, the route of the main power cable to the computer room must be determined, and a power distribution board and grounding cable facilities must be prepared.

### (2) Air conditioning facilities

#### a) Types of air conditioning facilities

Review the use of following air conditioning facilities as dedicated air conditioning facilities for computer rooms, for within power supply rooms, or for neighboring air conditioning rooms:

- Packaged air conditioner
- Air-handling unit

Regarding air conditioning for other locations, review the following facilities:

- Cooling tower
- Outdoor unit
- Chiller

Following the selection of the computer room, determining the location of the air conditioning facilities and routing of the pipeline will be required:

**b) Purpose of air conditioning**

In a computer room, there are many heat sources such as dissipation from server systems, heat from surrounding circumstances, and heat generated by lighting and operators' bodies that increase instability of air conditions in the room. Air conditioners are required in order to improve stability of air conditions in the room.

**c) Precautions**

Regarding the selection of air conditioning facilities, the following items require consideration:

- Air conditioning facilities needed to keep the server system running successfully
- For water-cooled air conditioners, the location of the cooling tower and coolant piping to the air conditioner
- For air-cooled air conditioners, the location of the air-cooled outdoor unit and refrigerant piping to the air conditioner
- Cooling water capacity to provide year-round cooling, for cases where only chilled water is available for cooling the building, and no locations are available for installing a cooling tower or outdoor unit

**(3) Telecommunications equipment**

The area or telecommunications equipment room in which telecommunications equipment is to be installed need to be reviewed.

**(4) Fire extinguishing facilities**

If fire extinguishing facilities are to be installed, a particular area is needed to install them.

**2.2.5 Access routes**

The process of installing a server system involves frequent carrying-in and out of equipment, at initial system setup, the addition of more equipment, upgrading, and so on. Before equipment is carried in, consideration should be given to the surrounding conditions of the building, the location where the equipment is to be unpacked, how the equipment is to be carried in, and temporary floor reinforcement along the access route. To this end, the user needs to review the access route from the opening in the building through which the equipment is carried into the computer room where the equipment is to be set up. The Fujitsu shipping coordinator may take a preliminary tour of the access route and conduct consultations with the user beforehand.

The items that require consideration are listed as follows:



- Where the equipment is to be unloaded from the transport vehicle
- How the equipment is to be carried in and out the building
- Where the equipment is to be temporarily stored and unpacked
- The size of the elevator and its loading capacity
- The carry-in access route to the computer room
- Whether floor protection along the access route is required

The access route from the building delivery entrance to the computer room is described below:

### **(1) Building delivery entrance**

#### **a) Carrying in equipment in a wooden crate or box**

When the server system to be carried in is enclosed in a wooden crate or box as is the case when shipped from the factory over a long distance to a user overseas, the building delivery entrance should generally have the following dimensions:

- Height: 2.5 m (8.2 ft) or more
- Width: 1.6 m (5.2 ft) or more

Because the wooden crate or box packaging dimensions for specific users depends on the kind of equipment to be packaged and the transportation method, the field representative in charge confers with the shipping department and notifies the user accordingly.

#### **b) Carrying in equipment with a crane**

Difficulties may be experienced in carrying equipment into the middle floor of a building directly with a crane, depending on the structure of the delivery entrance of the building and the surrounding conditions of the building. Prior consultation with the Fujitsu shipping coordinator is recommended.

### **(2) Computer room entrance and building passages**

The delivery entrance of the building into which equipment is to be carried in unpacked, the intermediate passages of the access route, and the entrance of the computer room must have the values specified below.

- The entrance of the computer room and the building passages should have a height of at least 20 cm (8 in.) more than the assumed equipment height.
- The entrance of the computer room and the building passages should have a width of at least 30 cm (12 in.) wider than an equipment width.

Besides this, the followings need to be taken into consideration.

- Enough space for negotiating corners along building passages
- Whether the elevator(s) of the building is available

### **(3) Withstand load and protection of the access route**

The withstand load of the access route should be large enough to support the mass and transportation activity concerning the server system.

At the time of transportation, the floor and wall surfaces along the access route may require protection.

### **2.2.6 Water and fuel stocks**

The quantities of water and fuels to be kept in stock should be calculated by taking into account the number of hours for which server service should be sustained, a factor that should be determined before proceeding with stock quantity calculation.

Primary considerations involved in the determination of stock quantities are as follows:

- Cooling water for air conditioning facilities and emergency power generation facilities
- Living utility water
- Fuels for emergency power generation facilities
- Fuels needed to heat or cool office rooms and rooms occupied by people

## **2.3 Computer Room Structure**

This section describes the structural requirements of computer rooms, free-access floors, and interior furnishings.

### **2.3.1 Computer room structural requirements**

The following items are requirements that should be taken into account at the time of computer room selection.

- Base floor strength and surface finishing
- Free-access floor
- Ceiling height
- Floor vibration
- Room location and access route
- Power supply
- Air conditioning facilities and external water chilling facilities

- Security and disaster prevention considerations

### (1) Base floor strength

The base floor on which the server system is to be set up must have enough strength to support a raised floor and facilities and equipment, as well as the server system itself. A floor top view with an equipment layout superimposed with equipment weights for each lockers must be presented to the building designer or the building constructor as a means of determining whether the server system can be installed on the floor in question.

For base floor strength, see [Section 2.2.1, "Building structures."](#)

### (2) Dustproof finishing

If the surface of the base floor is left unfinished, equipment may be adversely affected by calcium carbonate scattered as dust from the concrete surface. The concrete surface must be finished with a dustproof coating to prevent the buildup of dust.

### (3) Free-access floor construction

Server rooms covering an area of about 30 m<sup>2</sup> (320 ft<sup>2</sup>) or more should have a raised floor structure as far as circumstances allow. A raised floor structure with a free-access floor that allows floor plate removal is recommended to facilitate equipment installation and relocation, cabling, and underfloor ventilation. Requirements for the raised floor height of a free-access floor and the floor panel strength are described in [Section 2.3.2, "Free-access flooring."](#)

### (4) Ceiling height

The ceiling of the computer room must be high enough to allow for the circulation of cold air up from under the free-access floor to the heated equipment which it cools down before flowing unrestrained within the room back to the air conditioner. The ceiling height is measured from the surface of the free-access floor (raised floor) to the bottom layer of the double ceiling. The values specified in [Table 2.1](#) are required depending on the equipment height.

Table 2.1 Ceiling heights

Equipment height	Ceiling height
Up to 1.8 m (5.9 ft)	2.3 m (7.5 ft) or higher
Above 1.8 m (5.9 ft) but not exceeding 2.0 m (6.6 ft)	2.5 m (8.2 ft) or higher

## 2.3.2 Free-access flooring

The construction of free-access floors is reviewed with respect to the following items:

- Raised floor height
- Strength and surface material of free-access floor panels
- Opening for server-system-use
- Installation of floor panels for a building air conditioner

Each item is described as follows:

### (1) Raised floor height

Regarding the raised floor height of a free-access floor, the following factors require consideration:

- Availability of underfloor ventilation
- Cabling height
- Safeguards against earthquakes

[Table 2.2](#) lists suggested raised floor heights for free-access floors.

Table 2.2 Raised floor heights of free-access floors

Condition		Raised floor height
Room ventilation	Erected directly on the free-access floor Optional earthquake-free legs that absorb the energy of earthquakes installed to protect against earthquakes	180 mm (7 in.) or higher
	Clamped from under the free-access floor to protect against earthquakes	250 mm (10 in.) or higher
Underfloor ventilation	Erected directly on the free-access floor Optional earthquake-free legs that absorb the energy of earthquakes installed to protect against earthquakes	300 mm (12 in.) or higher
	Clamped from under the free-access floor to protect against earthquakes	400 mm (16 in.) or higher

## (2) Strength and surface material of free-access floor panels

Table 2.3 lists the strengths and surface materials suggested for free-access floor panels.

Table 2.3 Strengths and surface materials of free-access floor panels

Item		Condition
Floor-panel strength		Deflection not exceeding 1.5 mm (0.05 in.) under a concentrated load of 4.9 kN (1100 lbf)
Surface material	Suppression of static electricity	Volume resistivity falling $10^6$ to $10^9 \Omega$
	Oil resistance and ease of cleaning	Resistant to oils used during maintenance and easy to clean
	Dust buildup characteristics	Resistant to dust buildup

## (3) Opening for server-system-use

That area of the free-access floor in which a server system is installed requires a floor panel opening, an auxiliary support and a slit floor panel.

When Fujitsu receives a free-access floor allocation plan from the user after the finalization of an equipment layout, it will furnish an opening diagram marked with an opening pattern, an auxiliary support position, and a slit floor panel position.

The user then proceeds with construction of the floor panel opening, an auxiliary support, and slit floor panel on the basis of this opening diagram.

### a) Floor panel opening

That area of the free-access floor in which an equipment is installed must have an opening in the floor panel to facilitate equipment cabling and underfloor cold ventilation.

### b) Auxiliary supports

Depending on the shape of the floor panel opening, an auxiliary support may be required to augment panel strength and to secure the panel in a firm position. In installing equipment, such as a magnetic tape unit, on a floor panel, an auxiliary support should be used to reinforce the floor panel so that the equipment can be kept level by offsetting panel deflection.

### c) Slit floor panels

Depending on the heat dissipation and the air intake/exhaust structures of the equipment installed, a slit floor panel for cold ventilation may have to be installed in the service area.

Figure 2.1 shows the outer view of a slit floor panel.

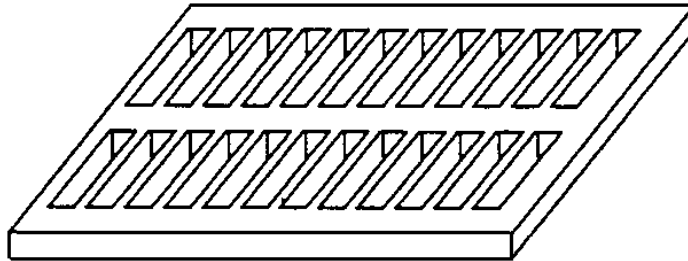

Figure 2.1 Slit floor panel

- d) Preventing the free-access floor from being collapsed because of the opening  
Horizontal forces applied to the free-access floor during earthquakes or when heavy equipment is carried in could cause the floor panel to shift, depending on the structure of the free-access floor and the shape of the floor panel opening, leading to free-access floor collapse. When such an opening is built, the free-access floor should be reinforced with bolts or brackets to guard against possible collapse.

#### **(4) Installation of a floor panel for a building air conditioner**

A floor panel must be installed only for buildings air conditioned by underfloor ventilation. When underfloor ventilation and room air conditioning are jointly used, the floor panel is not required.

##### **a) Underfloor ventilation**

If only underfloor ventilation is used to air condition the computer room, floor panels with an airflow control damper or airflow control panels must be installed to allow cold air to rise up from under the free-access floor to circulate outward into the room. This is proceeded to enable the air thus circulated may cool the heat penetrating the computer room, and heat generated by room lighting and by the operators' bodies.

The number of floor panels with an airflow control damper or number of airflow control panels required should be determined by the air conditioning facility or the free-access floor construction designer on the basis of the concerned heat load in the room.

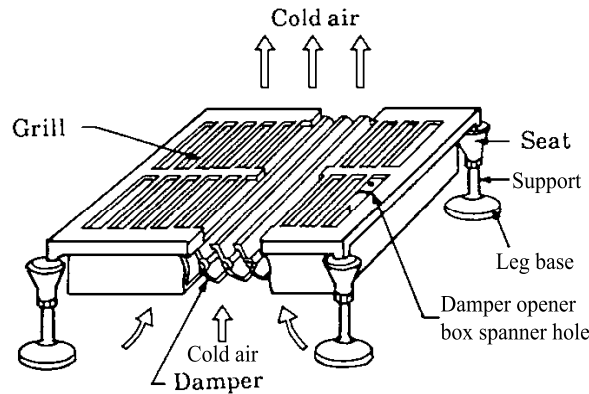

Figure 2.2 Floor panels with an airflow control damper

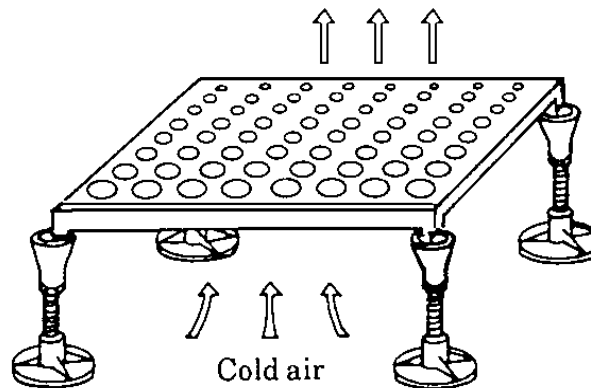

Figure 2.3 Air flow control panel

b) When underfloor ventilation and room air conditioning are combined

When underfloor ventilation is used to cool the equipment, with room air conditioning available to air condition the building in which the server system is housed, floor panels for the building's air conditioning system are not required.

### (5) Slopes and stairways

If there is a difference in levels between the base floor and the free-access floor, either a slope or stairway must be built at the entrance of the computer room to facilitate traffic or physical transportation.

## **(6) Base floor and free-access floor cleaning**

The base floor and the free-access floor require cleaning before the server system is installed. The following cleaning procedures are recommended, including those for cleaning the free-access floor surface periodically:

- 1 Remove dust on the surface of the panels.
- 2 Clean with a mop or cloth dipped in a solution having an anti-static agent, then squeeze the mop tightly before proceeding with mopping.

Never use polishing powder or solid or water-soluble waxes to clean computer rooms. They may become deposited in gaps in the floor surface or floor panels, then scattered by underfloor ventilation, penetrating inside the computers and affecting equipment adversely.

### **2.3.3 Interiors**

Server rooms require more strict temperature and humidity control than common office rooms. Essential things to consider with regard to such air conditioning include insulation against heat, prevention from entry of outside air, and shielding from direct sunlight. Cutting out heat from external sources would lessen the heat load of the building on the air conditioning facilities, leading to savings on expenditures on power required for air conditioning.

Other factors to consider with regard to computer room interiors include sounds absorption and insulation to suppress room noise, room lighting, and maintenance outlets.

#### **(1) Heat insulation**

The computer room should have a heat-insulating structure to cut heat penetrating through the walls, ceiling, windows, and other locations and to facilitate air conditioning. Heat insulation may be effected, for example, by the use of wind-free double walls and by finishing the walls, ceiling, and the ceiling of the floor immediately below with heat insulators of a noncombustible kind.



## **(2) Prevention of entry of outside air**

Outside air penetrating through gaps in a window could threaten successful temperature and humidity control of the air conditioning facilities.

Moreover, outside air might contain dust and harmful gases. From this standpoint, the windows in the computer room should be made airtight or semi-airtight. Openings that may allow the direct inflow of air from outside, from the floor right above or below, from passages, and elsewhere should be sealed. Outside air that is taken in must have its temperature and humidity regulated by an air conditioner before it can be fed into the computer room.

## **(3) Shielding from direct sunlight**

When direct sunlight enters the room through a window, it could produce local temperature increases in the room or in the equipment, adversely affecting the performance of such equipment. These windows must have blinds affixed to shield the room from direct sunlight.

## **(4) Sound absorption and insulation**

Appropriate sound absorption is recommended in the computer room to ease operator fatigue that may be caused by various kinds of noises generated in the room. Among all areas of the computer room, the ceiling and walls will make for the most effective sound absorbers when modified to this end. The use of noncombustible sound absorbers is recommended. The walls of the computer room should have a sound insulation structure to prevent noise from traveling imparted to adjoining offices, meeting rooms, etc.

If the floor is to be covered with carpeting as a sound absorber, such carpeting must be free of static electricity and dust.

## **(5) Lighting**

It is recommended that the computer room be illuminated to provide an illuminance of 400 to 600 lx at a point 85 cm (33 in.) above the floor for server system operation and maintenance purposes. Each lighting fixture should be furnished with a switch to turn off the light when it is not necessary.

## **(6) Maintenance outlets**

The computer room requires maintenance outlets to power instruments for maintaining the server system or to clean the floor. Maintenance outlets should be provided on column or wall surfaces 5 to 7 m (16 to 23 ft) apart at a height of about 30 cm (12 in.) above the floor. An extension cord is required where the outlet spacing exceeds 7 m (23 ft). Power leading to the outlets may be fed from a common general power source.

## **(7) Dust**

It is recommended to provide preventive action for generation of dust within the room in which the equipment is installed, and for entering of dust from the windows and entrances of the room. Most equipment applies mandatory cooling method. If dust particles adhere over the vent to shut down the airflow, the temperature inside the equipment ascends. Such conditions may cause equipment fault or system down. Dust may become a cause of readout malfunction when dust covers over magnetic tapes, optical disks, or such media. Planning of media warehousing is also important.

# CHAPTER 3 Equipment Layout

This chapter describes the items which considerations require for when laying out equipment. Equipment layout deserves special consideration, because it has a significant bearing on the efficiency of system operation and maintenance.

## 3.1 Proposed Computer Room Top View

A top view of the proposed computer room must be prepared.

### (1) Top view

A precise top view of the proposed computer room must be prepared to aid in reviewing the equipment layout.

### (2) Scale

The top view of the proposed computer room prepared on a scale of one-fiftieth is recommended.

## 3.2 Equipment Templates

Equipment templates at a scale of one-fiftieth are recommended. Prepare templates for the following kinds of equipment:

- Server system main unit
- Console tables
- Equipment installation shelves
- Cabinets used to house small floor-mounted equipment
- Air conditioners
- Power supply facilities

## **3.3 Precautions in Preparation of an Equipment Layout**

In preparing an equipment layout, take into account hardware constraints, operational considerations, and installation equipment constraints.

### **3.3.1 Hardware constraints**

#### **(1) Cable length limitations**

Each signal cable or power control cable has a limitation on its length. In laying out equipment, be careful not to exceed these limitations.

#### **(2) Wiring volumes and routes**

##### **a) Small systems**

In small systems involving a relatively low volume of wiring, equipment may be installed in an I, L or E-shaped layout to simplify the wiring routes on or under the floor.

Cover any wires or connections that are laid on the floor so that they do not interfere with traffic.

##### **b) Larger systems**

In larger systems with an increased volume of wiring, a free-access floor is required. This is a raised floor structure in which the floor plates are removable.

#### **(3) Heat dissipation from equipment**

If devices that dissipate a high amount of heat are used, they must not be concentrated within the same area considering air conditioning capability (1 or 2 kW/m<sup>2</sup>).

### **3.3.2 Operational considerations**

#### **(1) Equipment functionality and operability**

The components that make up a server system each have a specific functional goal to serve and should be grouped for ease of system operation.

Even if a single device has multiple functions, it should be grouped according to the degree to which it can be run with or without manual intervention.

Generally, devices may be divided into the following groups:

- Consoles for visual monitoring
- I/O devices requiring interchangeable and portable storage media
- Connection equipment that has a long service life and seldom requires replacement
- Data processing devices (such as CPUs and file units) that normally do not require manual operation

Figure 3.1 shows a conceptual view of grouping.

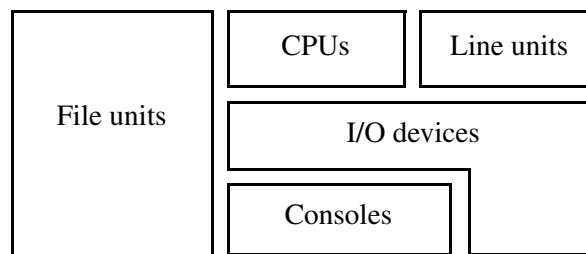

Figure 3.1 Concept of units operational grouping

## (2) Concentration of small equipment

Concentrate small devices, such as modems and LAN units, on shelves.

For a large number of small, floor-mounted devices, such as display controllers, LAN controllers, link adapters, and optical channel adapters, consider erecting a single cabinet to house them all.

## (3) Entrance and passage

Lay out the equipment to facilitate human traffic and the movement of supplies and storage media through the entrance. Allow also for human traffic and the movement of media, equipment, and instruments when locating the passages in the room.

## (4) Maintainability

Provide service clearance around server systems, air conditioners, and power supply facilities to allow access for inspection or maintenance.

## **(5) Acoustic noise**

A general-purpose server system is generally made up of a mix of equipment, each of which generates its own acoustic noise. Because the acoustic noises from individual equipment may result in a very high noise-level, it is recommended that these equipment be installed in an unattended zone.

### **a) Distinction between an attended zone and an unattended zone**

Install consoles and I/O equipment in a single attended zone, and data processors and file storage units in an unattended zone.

### **b) Attended zone**

Make sure that an attended zone is not surrounded by equipment on all sides. A wall may be erected on one side or it may be partitioned for sound insulation.

## **(6) Furniture and fixtures**

Provide locations for furniture and fixtures that are needed during operations.

Furniture and fixtures include:

- Cabinets used to store media
- Lockers used to store spare parts and documentation
- Forms storage stands

## **(7) Handling of vents**

Keep the inlet and outlet for air circulation and cooling equipment free from clogging up.

## 3.4 Air Conditioners

Factors to be considered when laying out air conditioning are described below:

### 3.4.1 Air conditioning units

Do not simply install a single, high-capacity central air conditioning unit in the computer room or an adjoining air-conditioning room. Considering possible device failures and the need for regular maintenance of air conditioning units, Fujitsu recommends installing multiple small-capacity air conditioning units (having a cooling power between 15 kW and 50 kW) at locations throughout the computer room. Ensure that the installation area, including maintenance space, is not unnecessarily large.

### 3.4.2 Air conditioning piping

When installing an underfloor-ventilation air conditioning unit, be careful to keep the piping from interfering with the underfloor ventilation or wiring. Construct the air conditioning piping upright from the floor above, below the ceiling, or on the back of the air conditioning unit.

### 3.4.3 Heat distribution

Devices that generate high heat should be installed at the place where the devices are cooled sufficiently by cold air from an air conditioner. Install air conditioners matched to the required heat dissipation in each area.

### 3.4.4 Air circulation

When installing air conditioners in the computer room, lay out the equipment to allow the air blown out from the air conditioner to circulate all around the equipment and then back to the air conditioner steadily so that stagnant air will not exist. Because airflow tends to stop around tall equipment, pay special attention to the relation between the location of tall equipment and the air outlet of the air conditioner.

In a system using underfloor ventilation for air conditioning, consider the paths of both hot and cold airflow.

### 3.4.5 Dusting

Units that use paper or toner in operation, such as line printers and laser printers, produce dust. The relation between dust-producing devices and device that should be dust-free requires special consideration. For example, dust-free devices can be installed near the air outlet, while the dust-producing devices can be near the air intake.

## 3.5 Power Supply Facilities

This section describes power supply facilities.

### 3.5.1 Power supply facilities for server system

The power supply facilities required for a server system include transformers, voltage regulators, and distribution panels. Some of these are installed in the server room.

[Table 3.1](#) summarizes the kinds, uses, and locations of the power supply facilities.

Table 3.1 Kinds, uses, and locations of power supply facilities (1/2)

Power supply	Use	Location
High-voltage transformers (dedicated to server systems or shared by other facilities)	Transforms a high transmission voltage into a commercial voltage.	Installed in a power user's electrical facility room, in a power company's transformer room, or on a pole.
Voltage regulators such as an uninterruptible power supply (UPS)	Compensates for momentary interruptions or voltage variations in commercial power.	Installed in a power user's electrical facility room or computer room. Generally, a UPS is installed in a dedicated electrical facility. A UPS rated at less than 100 kVA may be installed in a computer room.



Table 3.1 Kinds, uses, and locations of power supply facilities (2/2)

Power supply	Use	Location
Separate transformers	Low-voltage transformers used when: <ul style="list-style-type: none"> <li>• The supply voltage available to the building and the voltage required by the server system differ.</li> <li>• A voltage regulator, such as a UPS, is installed in a separate building or at a remote location.</li> <li>• Power is fed from a high-voltage transformer that is shared by other facilities, without using a voltage regulator.</li> </ul>	Separator transformers, when used, are typically installed in a computer room.
Step-down transformers (200 V to 100 V)	Transforms 200 V, from a high-voltage transformer and voltage regulator, to suit certain equipment which operates at 100 V.	Step-down transformers, when used, are typically installed in a computer room.
Distribution panels	Distributes power to server system.	Installed in a computer room.
Grounding facilities	Used to ground server system.	The grounding cable is led to the distribution panel for distribution.

### 3.5.2 Power supply facilities for air conditioners

Air conditioners or air conditioning control panels must be located for correct and efficient operation of the computer room.

### 3.5.3 Facility control panels

Facility control panels, which are used to run facilities in auto mode or shut them off immediately in an emergency, must be located to allow easy access.

## **3.6 Line and Signal Wiring Facilities**

This section describes line and signal wiring facilities.

### **3.6.1 Line facilities**

When line terminal boards and line terminals are installed, they must be located to allow for easy connection with any line units in the computer room.

### **3.6.2 Signal wiring facilities**

Signal cabling with devices that are installed outside the computer room requires wiring facilities, such as pipelines, ducts, and cable racks. Even though these units are located in an adjoining room, a through hole in the wall would still be necessary. Examine these wiring facility requirements and the location of any through holes during layout preparation and mark the top view of the proposed computer room accordingly.

# CHAPTER 4 Air Conditioning

This chapter describes which items require considerations when laying out air conditioning facilities.

## 4.1 Characteristics of Computer Room Air Conditioning

Computer room air conditioning is characterized by:

- Constant temperatures and humidities
- Air conditioning conditions and capacities
- Service time and reliability

These are detailed as below:

### 4.1.1 Constant temperatures and humidities

While most server system has wide permissible temperature and humidity ranges as described later, it is recommended that the computer room be maintained at a constant temperature and humidity to provide operational stability, fewer media effects, and a good operator environment. A stable environment is important because the computer room houses semiconductor devices, which are easily affected by thermal shocks, precision mechanical parts, which are liable to thermal expansion due to temperature changes, and print forms, toner, OMR and OCR forms, paper tape and other kinds of media, which are susceptible to the effects of humidity changes. A computer room requires temperature and humidity regulation, while guarding against electrostatic effects at low humidities and dew condensation caused by underfloor ventilation at lower temperatures and humidities.

### **4.1.2 Air conditioning conditions and capacities**

The air conditioning system must have the capacity to be able to process the amount of heat dissipated from the computer equipment to cool the computer room. A server system generates heat from the Power Supply Unit, semiconductor devices, etc. The rated or listed capacity of the air conditioning facilities may have been measured for a general office for human beings as specified by the relevant industrial standards or the like and may not be readily applicable to a server room environment. Consultation or design by a professional engineer is required for determining the capacity of an air conditioner to be used in a computer room.

### **4.1.3 Service time and reliability**

The air conditioning facilities for a computer room must be kept operable at all times. A large number of relatively low-capacity units are recommended. Maintain the room air at a somewhat lower temperature, so that even if one unit fails, there would still be time to take corrective action before a critical temperature is reached. The installation of spare units to back up the primary units is also recommended.

## **4.2 Styles of Air Conditioner**

Air conditioner installations for computer rooms can be grouped into four broad styles as listed below. Choose from them to suit the user's architectural requirements, the size of the system installation, layout constraints, etc.

- Direct blowing
- Duct blowing
- Underfloor ventilation
- Combined use of direct or duct blowing and underfloor ventilation

These methods are detailed as below:

### 4.2.1 Direct blowing

In the direct blowing setup, air conditioner(s) are installed in the computer room to blow air directly into the room.

This setup is economical, permits easy room temperature and humidity regulation, and is less susceptible to dew condensation. Moreover, the air conditioner(s), free from blowing temperature constraints, offer high working efficiency. However, while this setup is easier to install, cold air could be poorly distributed. Hence, a facility layout should be such as to ensure unrestricted flow of cold air. Another drawback is that where a high cooling capacity is required, rapid drafts of cold air could chill operators.

Generally, a unit installed in a direct blowing setup should include a draft fan, a cooling coil, a heater for the winter time, a humidifier, and a filter.

Figure 4.1 shows a schematic view of the direct blowing setup.

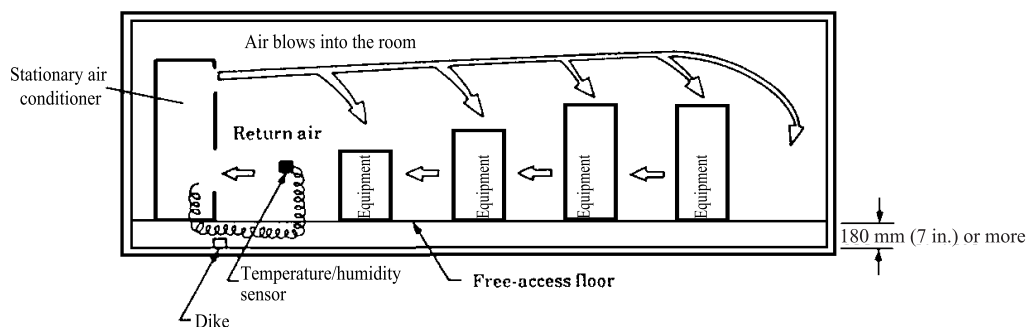

Figure 4.1 Direct blowing setup

### 4.2.2 Duct blowing

In the duct blowing setup, air duct is connected to an air conditioner so that cold air is blown from grille or spot in the computer room.

This setup features offering uniform blowing, permitting easy room temperature and humidity regulation, and lessening operator health effects. Its drawbacks, however, are the need for ducting in the ceiling, possible collision of air blowing from the ceiling with upward exhaust from the equipment, restricted equipment layout, and the difficulty of using centralized blowing against equipment which requires high heat dissipation.

An air conditioner installed in the duct blowing setup should include a cooling coil, a heater for the winter and temperature control, a humidifier, and a filter.

Figure 4.2 shows a schematic view of the duct blowing setup.

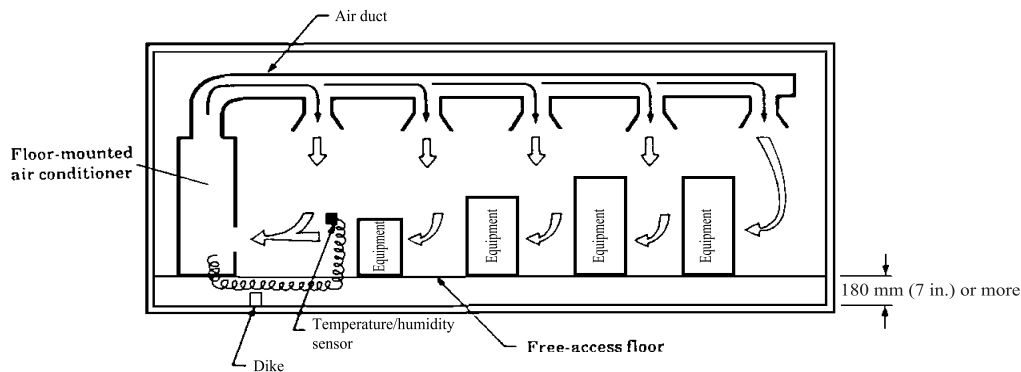

Figure 4.2 Duct blowing setup

### 4.2.3 Underfloor ventilation

In the underfloor ventilation setup, air blown out of the air conditioner is fed into the clearance between the free-access floor and the base floor, and is blown through openings in the free-access floor into the space at the bottom of the server system or the surrounding space.

This setup is useful in the following cases:

- Larger server systems including high heat dissipation volume unit(s)
- Intricate layout including tall equipment

This setup features the ability to keep operators less chilled because this lessens direct exposure to drafts of air blown out of the air conditioner. Because underfloor ventilation blows air directly against equipment, the air must be filtered for dust by the air conditioner beforehand. The lower the air temperature is, the greater the chance for dew condensation becomes because of increased humidity. Hence, the air requires regulation of both its temperature and humidity. A special underfloor-ventilation air conditioner dedicated to computer room use, which permits temperature and humidity regulation, is usually used. An air handling unit that uses a water-based cooling coil must be controlled to maintain the humidity, as well as the temperature, within a prescribed range. Regulation of the temperature and humidity in this setup is generally accomplished by cooling and dehumidifying the room air to a temperature lower than the target temperature and then heating and humidifying it to some degree to attain the target temperature and humidity. The cooling capacity of an air conditioner installed in this setup will be lower than its rating because of the internal heating process involved.

In the winter time, heating to a predetermined temperature is required.

Figure 4.3 shows a schematic view of the underfloor ventilation setup.

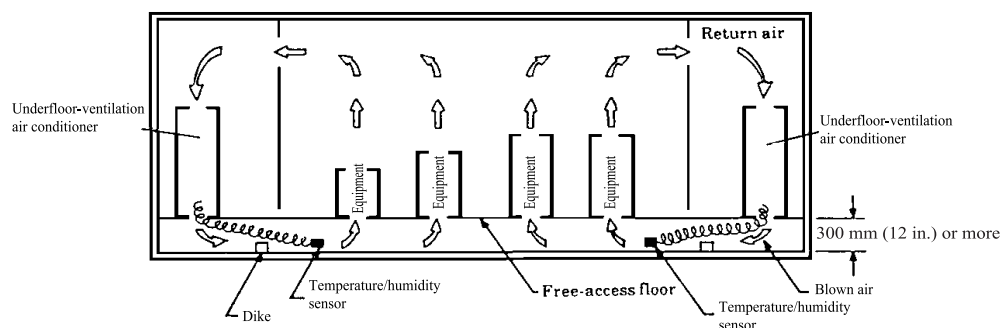

Figure 4.3 Underfloor ventilation setup

#### 4.2.4 Combined use of direct or duct blowing and underfloor ventilation

If direct blowing or duct blowing is combined with underfloor ventilation, the server system is cooled down by the air blown from under the floor, while the air in the room is conditioned to a temperature suitable for the operator by room air conditioning.

The underfloor-ventilation air conditioner dehumidifies the air by overcooling before regulating the temperature and humidity by heating and humidifying.

Sometimes the underfloor-ventilation air conditioner does not perform heating and humidifying but only cools the room air to the target temperature. In this situation, regulation of the temperature and humidity of the air in the room and under the floor can be accomplished by heating and humidifying the room air and the outside air after it has been dehumidified by overcooling by the underfloor air conditioner.

Figure 4.4 shows a schematic view of a combined system.

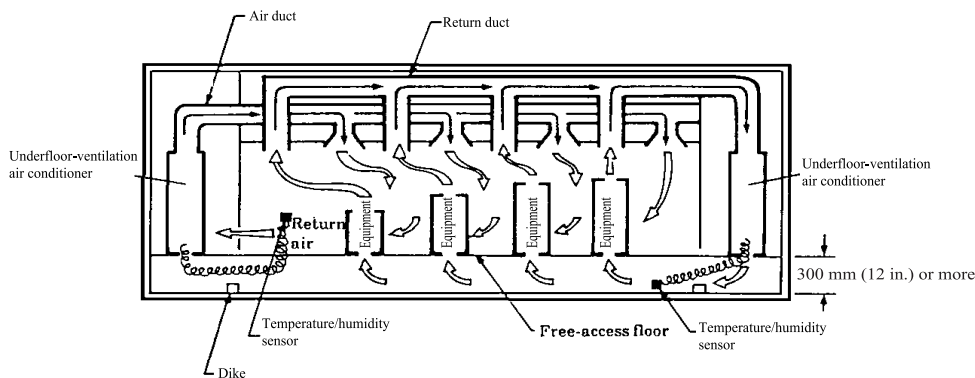

Figure 4.4 Schematic view of a combined system

## 4.3 Air Conditioning Conditions

This section describes air conditioning conditions.

### 4.3.1 Permissible temperature and humidity ranges for server systems

Each component of a server system has its own permissible temperature and humidity ranges, within which its operability is guaranteed. The prescribed temperature and humidity are those at the air vents of the component. For the permissible temperature and humidity ranges, see the Installation Planning Manual for each device.



### 4.3.2 Recommended temperatures and humidities for computer rooms

Keep the ambient temperature in the computer room at a level that feels comfortable to the human body or somewhat lower. This precaution will not only prevent local temperature rises in the computer room, such as those caused by equipment which requires high heat dissipation, or stagnant air circulation, but will also allow some time before the upper-limit temperature is reached even if the air conditioner fails.

In underfloor ventilation, humidity considerations require special consideration. Normal air contains vapor. The higher the temperature is, the lower the relative humidity is; the lower the temperature is, the higher the relative humidity is. For example, air at a temperature of 24°C (75°F) with a relative humidity of 45% would have a relative humidity of 65% at a temperature of 18°C (64°F), and could have a still higher relative humidity as the temperature falls.

Air conditioners are not designed to detect subtle changes in temperature and humidity in the entire computer room space. Generally, air conditioning is controlled by detecting and regulating the temperature and humidity at the main unit or at each of multiple air outlets. An air conditioner installed for underfloor ventilation detects and regulates the temperature and humidity at a point near each air outlet. As such, a nonuniform distribution of temperature and humidity may occur in the computer room.

[Table 4.1](#) lists recommended temperatures and humidities for computer rooms.

Table 4.1 Recommended temperatures and humidities for computer rooms

Air conditioning setup	Near the underfloor air outlet			Detection and regulation point			Remarks
	Temperature		Humidity %	Temperature		Humidity %	
	°C	°F		°C	°F		
Direct blowing or duct blowing	—	—	—	24 ±2 °C	75±4°F	45±5%	—
Underfloor ventilation	18±1 °C	64±2 °F	65±5%	Targeted at 24 °C	Targeted at 75°F	About 45% at 24°C (75°F)	The temperature and humidity depend on the thermal load.
Combined direct blowing or duct blowing and underfloor ventilation	18±1 °C	64±2 °F	65±5%	24 ±2 °C	75±4°F	45±5%	—

### 4.3.3 Temperature and humidity recommendations for computer rooms

Practical temperature and humidity recommendations that apply to changing the room temperature from the basic recommendations or to lowering the underfloor temperature in unattended areas where paper is not used are explained below.

#### (1) Changing the room temperature

Before changing the room temperature of a computer room from the basic recommendations consider the following:

- Keep the room humidity constant when direct blowing or duct blowing is used.
- If underfloor ventilation and room air conditioning is combined, keep the absolute temperature, which is a measure of the water content of the room air, equivalent to a temperature of 24°C (75°F) and a humidity of 45%. Do not change the flow rate even if the underfloor temperature is changed.

Table 4.2 summarizes the practical temperature and humidity recommendations that apply to changing the temperature from the basic recommendations.

Table 4.2 Temperature and humidity recommendations (changing the room temperature)

Air conditioning setup	Near the underfloor air outlet		Humidity	Detection and regulation point		Humidity %	Remarks
	Temperature			Temperature			
	°C	°F	%	°C	°F		
Direct blow or duct blow	—	—	—	Setting: Between 21 and 26 Width of variation: $\pm 2$ °C	Setting: Between 70 and 79 Width of variation: $\pm 4$ °F	$45 \pm 5\%$	—
Underfloor ventilation	$18 \pm 1$ °C	$64 \pm 2$ °F	$65 \pm 5\%$	Targeted at 24 °C	Targeted at 75 °F	About 45% at 24°C (75°F)	The temperature and humidity depend on the thermal load. Do not change the flow rate even if the underfloor temperature is changed.
	$19 \pm 1$ °C	$66 \pm 2$ °F	$62 \pm 5\%$	Targeted between 24 and 25°C	Targeted between 75 and 77 °F	About 43% at 24°C (75°F)	
	$20 \pm 1$ °C	$68 \pm 2$ °F	$58 \pm 5\%$	Targeted between 24 and 26 °C	Targeted between 75 and 79 °F	About 40% at 26°C (79°F)	
Combined use of direct blowing or duct blowing and underfloor ventilation	$18 \pm 1$ °C	$64 \pm 2$ °F	$65 \pm 5\%$	$24 \pm 2$ °C	$75 \pm 4$ °F	40 to 50%	Do not change the flow rate even if the underfloor temperature is changed.
	$19 \pm 1$ °C	$66 \pm 2$ °F	$62 \pm 5\%$	$25 \pm 2$ °C	$77 \pm 4$ °F	40 to 48%	
	$20 \pm 1$ °C	$68 \pm 2$ °F	$58 \pm 5\%$	$26 \pm 2$ °C	$79 \pm 4$ °F	40 to 45%	

Figure 4.5 is an air-line diagram depicting the relationships between the dry-bulb temperature, relative humidity, and absolute temperature.

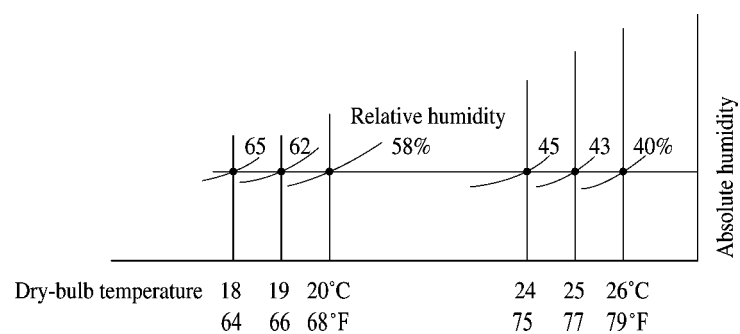

Figure 4.5 Psychrometric chart applicable to changing the room temperature

## (2) Lowering the underfloor temperature

In unattended areas where paper is not used and where only those devices that have broad permissible underfloor and room temperature and humidity ranges are installed, the underfloor temperature may be lowered. As an example, in an unattended room associated with a large system installation involving multiple computer rooms, hold the underfloor relative humidity to 70% or below to keep the room humidity at a lower level.

Table 4.3 summarizes the practical temperature and humidity recommendations that apply to lowering the underfloor temperature.

Table 4.3 Temperature and humidity recommendations (lowering the underfloor temperature)

Air conditioning setup	Near the underfloor air outlet			Detection and regulation point			Remarks
	Temperature		Humidity %	Temperature		Humidity %	
	°C	°F		°C	°F		
Underfloor ventilation	17±1 °C	63±2 °F	65±5%	Targeted at 24 °C	Targeted at 75 °F	About 42% at 24°C (75°F)	The temperature and humidity depend on the thermal load.
	16±1 °C	61±2 °F	65±5%	Targeted at 24 °C	Targeted at 75 °F	About 40% at 24°C (75°F)	
Combined use of direct blowing or duct blowing and underfloor ventilation	17±1 °C	63±2 °F	65±5%	24±2 °C	75±4 °F	42±5%	—
	16±1 °C	61±2 °F	65±5%	24±2 °C	75±4 °F	40±5%	

Figure 4.6 is an air-line diagram applicable to lowering the underfloor temperature.

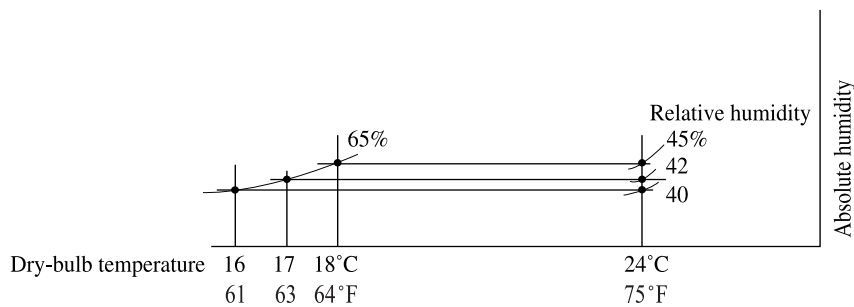

Figure 4.6 Psychrometric chart applicable to lowering the underfloor temperature

## 4.3.4 Dust

### (1) Airborne dust

Ensure that airborne dust does not exceed 0.15 mg/m<sup>3</sup> (0.004 mg/ft<sup>3</sup>). Most server systems are designed to withstand this level of airborne dust. This is the same as the permissible level for airborne dust in a general office and should be easily attainable in a computer room where there is little inflow of outside air and smoke.

### (2) Removing dust

Airborne dust is collected by air filters in the air conditioner. For air filter, see [Section 4.5.2, "Air conditioner filters."](#) The computer room must be periodically cleaned to remove dust on and under the floor. For cleaning procedures, see (6), ["Base floor and free-access floor cleaning,"](#) in 2.3.2, ["Free-access flooring."](#)

Cleaning is required in the following situations:

- When the construction of the computer room has just been completed, and it is ready to house equipment.
- When the computer room has been repaired.
- When equipment already in position in the computer room has been relocated. Areas surrounding printers and for forms handling require periodic cleaning.

## 4.3.5 Corrosive gases

Corrosive gases must be removed and kept out by using appropriate air cleaning facilities. Maintaining positive pressure in the computer room with filtered air will serve as a safeguard against the entry of corrosive gases or dust from an outside source.

[Table 4.4](#) lists the tolerable limits for different kinds of corrosive gases.

Table 4.4 Tolerable limits for corrosive gases (1/2)

Gas name	Tolerable limit
Hydrogen sulfide (H <sub>2</sub> S)	Up to 7.1 ppb
Sulfur dioxide (sulfur oxide) (SO <sub>2</sub> )	Up to 37 ppb
Hydrogen chloride (HCl)	Up to 6.6 ppb
Chlorine (Cl <sub>2</sub> )	Up to 3.4 ppb
Hydrogen fluoride (HF)	Up to 3.6 ppb

Table 4.4 Tolerable limits for corrosive gases (2/2)

Gas name	Tolerable limit
Nitrogen dioxide (nitrogen oxide) (NO <sub>2</sub> )	Up to 52 ppb
Ammonia (NH <sub>3</sub> )	Up to 420 ppb
Ozone (O <sub>3</sub> )	Up to 5 ppb
Oil vapor	Up to 0.2 mg/m <sup>3</sup>

### 4.3.6 Seawater (salt damage)

The air in the vicinity of coastal areas contains large amounts of airborne sea salt particles. If these particles remain inside computers, substances are formed by a condensation reaction of chemicals. These substances and the humidity lead to insulation failure and the corrosion and deterioration of components and materials. Therefore, computers should be installed in locations at a distance from coastal areas. The following outlines installation criteria for preventing salt water damage due to airborne sea salt particles.

Criteria: The installation site shall not be within 0.5 km of the ocean or coastal areas (unless the computer room uses air conditioners to filter out airborne sea salt particles from outside air).

## 4.4 Thermal Load and Cooling Capacities

The thermal load imposed on an air conditioner must include those coming from the power supply facilities and from the building, as well as heat from the server system itself.

Air conditioning of computer rooms in comparison with normal offices is characterized by the following:

- Sensible heat accounts for a greater percentage of the heat which causes temperature rises, with lesser latent heat relating to outside air and vapor from human bodies. The flow rate of the air conditioner needs to be able to cool sensible heat.
- While the common room temperature and humidity requirements are 24°C (75°F) (dry-bulb temperature) and 45% (relative humidity), the ratings of air conditioners are usually stated at 27°C (81°F) and 50%.

Hence, it is more desirable to determine the cooling capacity of an air conditioner on the basis of its test data, rather than its stated ratings. Possible sources of thermal load that are imposed on air conditioners, examples of cooling capacity calculations, and convenient formulas to work out air conditioning capacities are described below:

### 4.4.1 Thermal load imposed on air conditioner

The thermal load that is imposed on an air conditioner in a server room can generally be calculated by summing up the amount of heat dissipation listed in [Table 4.5](#).

Table 4.5 Sources of overload and amount of heat dissipation

Source of heat	Amount of heat dissipation
Heat from the server system	Amount of heat dissipation calculated from the specification of the individual devices.
Heat from the power supply facilities	Amount of heat dissipation from the stepdown transformer, automatic voltage regulator (AVR), or uninterruptible power supply (UPS).
Heat from outside the room (walls, partitions, windows, ceiling, floor, etc.)	A computer room in a steel-framed reinforced concrete building built in Japan typically has a heat dissipation of about 420 kJ/h per 1m <sup>2</sup> (36.9 Btu/h per 1 ft <sup>2</sup> ). This approximate value depends on the district in which the building exists, its structure, the orientation of the room, and other relevant conditions.
Heat from outside air taken in, from natural ventilation, etc.	
Heat from lighting fixtures	
Heat from human bodies	

### 4.4.2 Example of cooling capacity calculations for room air conditioning

Examples of cooling capacity calculations for an air conditioner, flow rate 135 m<sup>3</sup>/min (4770 ft<sup>3</sup>/min), running in a room air conditioning setup are given below.

The following values have been determined with respect to the rated capacity of 167.4 MJ/h (158,700 Btu/h):

- The cooling capacity is 145.6 MJ/h (138,000 Btu/h), 87% of the capacity rating.
- The sensible heat capacity is 124.4 MJ/h (117,900 Btu/h), 74% of the capacity rating.

Figure 4.7 shows typical air conditioner characteristics, and Figure 4.8 shows the air condition in a psychrometric chart.

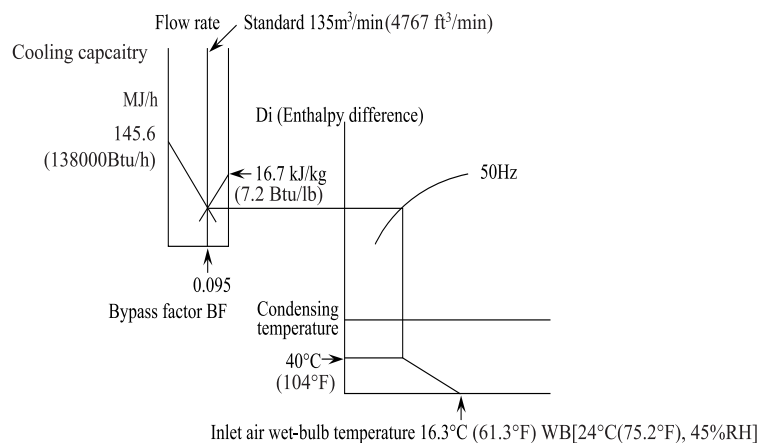

Figure 4.7 Typical air conditioner characteristics

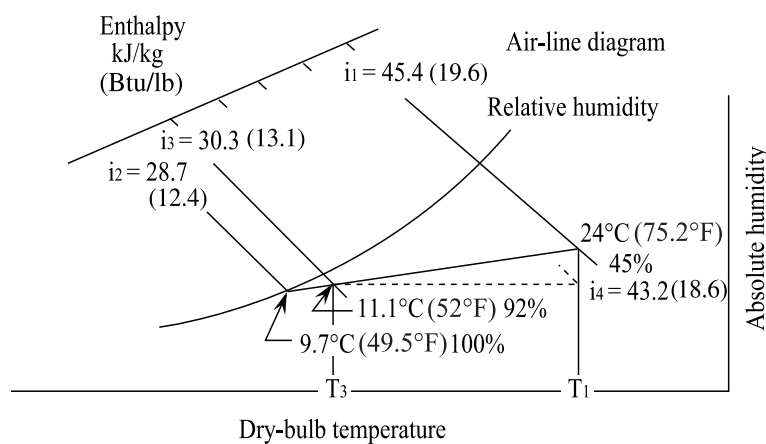

Figure 4.8 Air condition in a psychrometric chart (for a typical air conditioner)

Table 4.6 summarizes procedures that can be used to calculate the cooling capacities of a typical air conditioner from its characteristics and psychrometric chart.



The values in the table involve certain characteristic curve and air-line diagram read errors.

Table 4.6 Examples of typical air conditioner cooling capacity calculations (1/2)

Item	Calculated value	Calculation method
Enthalpy of the air at the conditioner inlet	$i_1=45.4$ kJ/kg (19.6 Btu/lb)	Determine the enthalpy at 24°C (75.2°F) and 45%RH from the air-line diagram
Enthalpy difference between the air conditioner coil inlet and the coil surface	$\Delta i=16.7$ kJ/kg (7.2 Btu/lb)	Determine the difference from typical air conditioner characteristics.
Enthalpy on the air conditioner coil surface	$i_2=28.7$ kJ/kg (12.4 Btu/lb)	Determine the enthalpy from the air-line diagram.
Air conditioner bypass factor	BF=0.095	Determine the bypass factor from typical air conditioner characteristics.
Enthalpy of the air coming out of the air conditioner	$i_3=30.3$ kJ/kg (13.1 Btu/lb)	Calculate the enthalpy by solving the bypass factor relation $BF = (i_3 - i_2) / (i_1 - i_2)$ .
Temperature and humidity at the inlet	24°C (75.2°F) 45%	Setup condition
Enthalpy on the air conditioner coil surface	9.7°C (49.5°F) 100%	Determine the temperature and humidity from the point of intersection between the enthalpy ( $i_2$ ) on the air conditioner coil surface and 100% relative humidity in the air-line diagram.
Temperature and humidity of the air coming out of the air conditioner	11.1°C (52°F) 92%	Determine the temperature and humidity from the point of intersection of a line segment, between the status point at the conditioner inlet and that on the air conditioner coil surface, and the enthalpy of the air coming out of the air conditioner in the air-line diagram.
Air conditioner cooling capacity	145.6 MJ/h (138,029 Btu/h)	$(i_1 - i_3) \times \text{Flow rate} / \text{Specific volume}$ $= 15.1 \text{ (kJ/kg)} \times 135 \text{ (m}^3\text{/min)} \times$ $60 \text{ (min/h)} / 0.84 \text{ (m}^3\text{/kg)}$ $= 6.5 \text{ (Btu/lb)} \times 4770 \text{ (ft}^3\text{/min)} \times$ $60 \text{ (min/h)} / 13.5 \text{ (ft}^3\text{/lb)}$

Table 4.6 Examples of typical air conditioner cooling capacity calculations (2/2)

Item	Calculated value	Calculation method
Air conditioner sensible heat cooling capacity (when calculated on the basis of sensible heat enthalpy differences)	124.4 MJ/h (117,931 Btu/h)	$(i_4 - i_3) \times \text{Flow rate} / \text{Specific volume}$ $= 12.9 \text{ (kJ/kg)} \times 135 \text{ (m}^3/\text{min)} \times 60 \text{ (min/h)} /$ $0.84 \text{ (m}^3/\text{kg)}$ $= 5.5 \text{ (Btu/lb)} \times 4770 \text{ (ft}^3/\text{min)} \times$ $60 \text{ (min/h)} / 13.5 \text{ (ft}^3/\text{lb)}$
Air conditioner sensible heat cooling capacity (when calculated on the basis of temperature differences)	124.4 MJ/h (117,931 Btu/h)	$(T_1 - T_3) \times \text{Specific heat} \times \text{Flow rate} / \text{Specific volume}$ $= (24 - 11.1)(^\circ\text{C}) \times 1 \text{ [kJ/(kg} \cdot ^\circ\text{C)]}$ $\times 135 \text{ (m}^3/\text{min)} \times 60 \text{ (min/h)}$ $/ 0.84 \text{ (m}^3/\text{kg)}$ $= (75.2 - 52)(^\circ\text{F}) \times 0.24 \text{ [Btu/(lb} \cdot ^\circ\text{F)]} \times 4770$ $\text{(ft}^3/\text{min)} \times 60 \text{ (min/h)} / 13.5 \text{ (ft}^3/\text{lb)}$

### 4.4.3 Underfloor ventilation air conditioning

Figure 4.9 shows the air condition for underfloor ventilation in a psychrometric chart. Table 4.7 summarizes procedures for calculating the cooling capacities of an underfloor-ventilation air conditioner, flow rate 220 m<sup>3</sup>/min (7770 ft<sup>3</sup>/min).

The values in the table involve certain characteristic curve and psychrometric chart read errors.

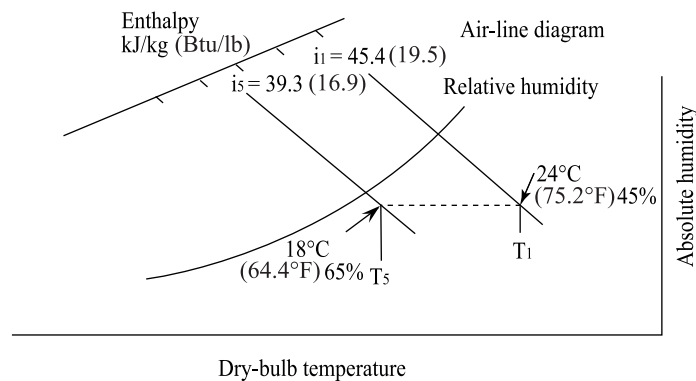

Figure 4.9 Air condition in a psychrometric chart (underfloor-ventilation air)

Table 4.7 Examples of underfloor-ventilation air conditioner cooling capacity calculations (1/2)

Item	Calculated value	Calculation method
Temperature and humidity at the inlet	24°C (75.2°F) 45%	Setup condition
Temperature and humidity of the air coming out of the air conditioner	18°C (64.4°F) 65%	Setup condition
Air conditioner sensible heat cooling capacity (when calculated on the basis of temperature differences)	94.3 MJ/h (89400 Btu/h) at a flow rate of 220 m <sup>3</sup> /min (7770 ft <sup>3</sup> /min)	$(T_1 - T_5) \times \text{Specific heat} \times \text{Flow rate} / \text{Specific volume}$ $= (24 - 18)(^\circ\text{C}) \times 1 [\text{KJ}/(\text{kg } ^\circ\text{C})] \times 220 (\text{m}^3/\text{min}) \times 60 (\text{min/h}) / 0.84 (\text{m}^3/\text{kg})$ $= (75.2 - 64.4)(^\circ\text{F}) \times 0.24 [\text{Btu}/(\text{lb} \cdot ^\circ\text{F})] \times 7770 (\text{ft}^3/\text{min}) \times 60 (\text{min/h}) / 13.5 (\text{ft}^3/\text{lb})$
Enthalpy of the air at the conditioner inlet	$i_1 = 45.4 \text{ kJ/kg}$ (19.5 Btu/lb)	Determine the enthalpy at 24°C (75.2°F) and 45% RH from the air-line diagram.

Table 4.7 Examples of underfloor-ventilation air conditioner cooling capacity calculations (2/2)

Item	Calculated value	Calculation method
Enthalpy of the air coming out of the air conditioner	$i_5 = 39.3 \text{ kJ/kg}$ (16.9 Btu/lb)	Determine the enthalpy at 18°C (64.4°F) and 65% RH from the air-line diagram.
Air conditioner sensible heat cooling capacity (when calculated on the basis of sensible heat enthalpy difference)	95.9 MJ/h(90900 Btu/h) at a flow rate of 220 m <sup>3</sup> /min (7770ft <sup>3</sup> /min)	$(i_1 - i_5) \times \text{Flow rate/Specific volume}$ $= 6.1(\text{kJ/kg}) \times 220 (\text{m}^3/\text{min}) \times 60 (\text{min/h}) / 0.84 (\text{m}^3/\text{kg})$ $= 2.6(\text{Btu/lb}) \times 7770 (\text{ft}^3/\text{min}) \times 60 (\text{min/h}) / 13.5 (\text{ft}^3/\text{lb})$

#### 4.4.4 Convenient formulas for air conditioning capacities

Table 4.8 lists convenient formulas for the capacity of air conditioners installed in a computer room. Because a proportion of the thermal load comes from sensible heat, the capacity and number of air conditioners required can be determined by calculating the flow rate requirement relating to sensible heat. Actual air conditioning design should allow for air conditioner characteristics, building thermal load calculations, etc.

Table 4.8 Convenient formulas for air conditioner capacity

Air conditioning setup	Flow rate calculation formula
Room air conditioning	Flow rate (m <sup>3</sup> /min) $\cong \frac{\text{Thermal load (kJ/h)}}{1.0/0.84 \times (24^\circ\text{C} - 11^\circ\text{C}) \times 0.9 \times 60}$
	Flow rate (ft <sup>3</sup> /min) $\cong \frac{\text{Thermal load (Btu/h)}}{0.24/13.5 \times (75.2^\circ\text{F} - 52^\circ\text{F}) \times 0.9 \times 60}$
Underfloor ventilation	Flow rate (m <sup>3</sup> /min) $\cong \frac{\text{Thermal load (kJ/h)}}{1.0/0.84 \times (24^\circ\text{C} - 18^\circ\text{C}) \times 60}$
	Flow rate (ft <sup>3</sup> /min) $\cong \frac{\text{Thermal load (Btu/h)}}{0.24/13.5 \times (75.2^\circ\text{F} - 64.4^\circ\text{F}) \times 60}$

The formula terms are:

- Flow rate: Sensible heat from the thermal load divided by the temperature difference and the heat removed to cool a unit volume by 1°C (34°F).

$$\text{Flow rate} = \frac{\text{Sensible heat from thermal load}}{\text{Temperature difference} \times \text{Specific heat/Specific volume}}$$

- Thermal load: While the thermal load is a sum of sensible heat and latent heat, sensible heat accounts for such a large proportion of the thermal load in a computer room that the thermal load is assumed to be equal to the sensible heat.

Thermal load = Sensible heat + Latent heat  $\approx$  Sensible heat

- 1.0 or 0.24: Specific heat of the air [kJ/(kg · °C)] or [Btu/(lb · °F)]
- 0.84 or 1.35: Specific volume of the air (m<sup>3</sup>/kg) or (ft<sup>3</sup>/lb)
- 24°C or 75.2°F: Air conditioner inlet air temperature
- 11°C or 52°F: Approximate temperature of the air on the coil surface of a room air conditioner
- 0.9: Approximate bypass factor of a room air conditioner
- 60: Conversion to minutes (min/h)
- 18°C or 64.4°F: Outlet air temperature of an underfloor-ventilation air conditioner

## 4.5 Precautions Pertaining to the Installation of Air Conditioners

Air conditioners that are installed in computer rooms differ in many ways from those installed in general offices. Precautions specific to installing air conditioners in a computer room are summarized below.

### 4.5.1 Humidifier

The reason a humidifier is needed, types of humidifiers available, and humidifiers used with underfloor-ventilation air conditioners are described below.

#### (1) Why a humidifier is needed?

In the winter time, drops in the relative humidity of the air in the computer room make it more susceptible to the generation of static electricity. To prevent this, a humidifier must be installed to raise the relative humidity of the room air.

#### (2) Types of humidifiers and replacement water

Use of a humidifier that generates steam by boiling water is recommended.

Using a boiling humidifier will cause impurities in the water to be precipitated and should have automatic or periodic discharge and replacement of the water.

A spraying humidifier (for example, ultrasonic humidifier, water spray, or centrifugal sprayer) discharges fine drops of water into the air in vapor form. With this type of humidifier, impurities in the water could adhere to the equipment or supplies as white powder. This white powder can be a source of numerous problems, including defective insulation, rusting, clogged filters, or poor contact, and might also scratch the surfaces of magnetic disks, resulting in loss of data.

When using spray humidifiers including ultrasonic humidifier, be sure to maintain the purity of distilled water.

The following conditions must be considered when using purifiers.

- Let distilled water pass the ion exchange resin of the purifier. The conductivity of water after passing a purifier must not exceed 2  $\mu\text{S}/\text{cm}$ .
- Use a purifier that detects problems in the ion exchange resin automatically to sustain the performance of the purifier. When problems are detected, replace the ion exchange resin.

### **(3) Humidifiers used with underfloor-ventilation air conditioners**

Certain types of underfloor-ventilation air conditioners have a boiling humidifier and a draft fan installed at adjacent locations such that drops of boiling water from the humidifier can enter the draft fan for aerial dispersion. If this occurs, impurities in the drops of water can adhere to the air inlet of the equipment as white powder or turn into sandy particulate under the floor and cause corrosion.

Care should be taken in selecting or designing an air conditioner to prevent the dispersion of drops of boiling water from a boiling humidifier. In scheduled facility checkouts, check for white powder on the draft fan, sandy particulate under the floor, and white powder on the air inlets of the equipment and any resultant corrosion to ensure that the air conditioner is working correctly.

## **4.5.2 Air conditioner filters**

Use filters that provide a high collection efficiency and that do not have any adverse effects on the server system. Also install a filter at the outside air inlet to remove dust from the outside air.

### **(1) Filter collection efficiency**

Use of a filter with a collection efficiency of 95% or higher as measured by the gravimetric method is recommended.

### **(2) Filter types**

Filters must be mechanical ones made of a nonwoven cloth or similar material. Do not use electrostatic dust collectors as they generate ozone gases, which could degrade rubber parts.

### 4.5.3 Installing temperature/humidity sensors

Temperature/humidity sensors used to regulate the temperature and humidity of an air conditioner are installed at different positions according to the ventilation method.

#### (1) Location of temperature/humidity sensors for a room air conditioner

Location to install temperature/humidity sensors for a room air conditioner is:

- At a height of about 1 to 1.5 m (3.3 to 4.9 ft) above the floor
- Where measuring the mean temperature and humidity is available
- Where they are not exposed to direct drafts of cold air from the air conditioner or air emissions from the equipment

#### (2) Location of temperature/humidity sensors for an underfloor-ventilation air conditioner

Location to install a temperature/humidity sensor for a underfloor-ventilation air conditioner is:

- Under the floor 1 to 1.5 m (3.3 to 4.9 ft) from the air outlets
- Where they are readily accessible for inspection

### 4.5.4 Taking in fresh air

Fresh air needs to be drawn into the computer room for operators.

#### (1) Volume of fresh air

Fresh air should be taken in at a rate of about 30 m<sup>3</sup>/h (1100 ft<sup>3</sup>/h) per operator present. Where outside air is taken in through a duct, and not by natural ventilation through ventilation, dust must be removed and its temperature and humidity regulated before it can be fed into the room or under the floor.

#### (2) Preventing natural inflow of outside air

Install a closing damper at the outside air intake duct. Keep it closed to prevent the natural inflow of outside air while the air conditioner is shut down. Prevent natural inflow of outside air through ventilation.



### 4.5.5 Preventing dew condensation in underfloor ventilation

In underfloor ventilation, provisions should be made to prevent dew condensation inside and outside of devices installed in the computer room as they are exposed to direct drafts of cold air from the air conditioner. Devices are susceptible to dew condensation if they are at a low temperature while the room temperature is low and also if the air inside and outside the room is at a high temperature and a high humidity. Further, where both the temperature and humidity are regulated from the beginning, the underfloor air could be dampened and cause dew condensation.

The air conditioning control scheme must be examined and established on the user's own responsibility to meet their own needs. Typical air conditioning control schemes are described below.

#### (1) If the room temperature is low

If the room is in low temperature, the devices installed in the computer room is also cool. When this occurs, follow the procedure below to start the humidifiers.

- 1** Stop the humidifier of the air conditioner(s).
- 2** After reaching the target temperature only with the air conditioner in heating-drive mode, turn on the server systems.
- 3** Change the drive mode of the air conditioner to cooling-drive.
- 4** When room temperature reaches stable circumstance, start operating the humidifiers.

#### (2) If the room air is at a high temperature and a high humidity

If the room air is at a high temperature and a high humidity, the room humidity will rise sharply when the air conditioner starts to deliver low-temperature air. When this occurs, follow the procedure below to start operating the air conditioning.

- 1** Bring the room air to the target temperature and humidity points slowly while dehumidifying the air with a high blow temperature setting and a low humidity setting. Keep the dehumidifier stopped in the meantime.  
If the room humidity does not fall below its target point before the dehumidifier is run, the following are conceivable:
  - Failing to dehumidify the air because reheater that regulates the temperature after room air has been cooled may not operate.
  - Outside air penetrating the room through gaps.

In this case, the facilities and building must be checked.

- 2** When temperature reaches the target range, turn on the server system. The humidifier may operate after the room temperature reaches a stable state.

### (3) Example of stopping humidifier upon starting up of the server system

In underfloor ventilation, if heat dissipation from server system during startup of the equipment leads transition of drive condition of the air conditioners, and the room is dampened heavily so that the room is brought to high humidity, dew condensation may be caused in the server system. In such case, to prevent high humidity or dew condensation, stop the humidifier before turning on the server system, restart the humidifier when the temperature is stabilized after server system is turned on.

#### 4.5.6 Preventing water leaks and installing detectors

Ensure that water leaks, resulting from failures in the air conditioner or water piping or clogged drain pipes, will not spread to under the raised floor or over the floor surface. When water leaks occur, they should be detected immediately. It is recommended that dikes or similar fences be made around the air conditioner and that leak detectors be installed inside the dike and around the water pipeline.

Figure 4.10 is a schematic view of a dike.

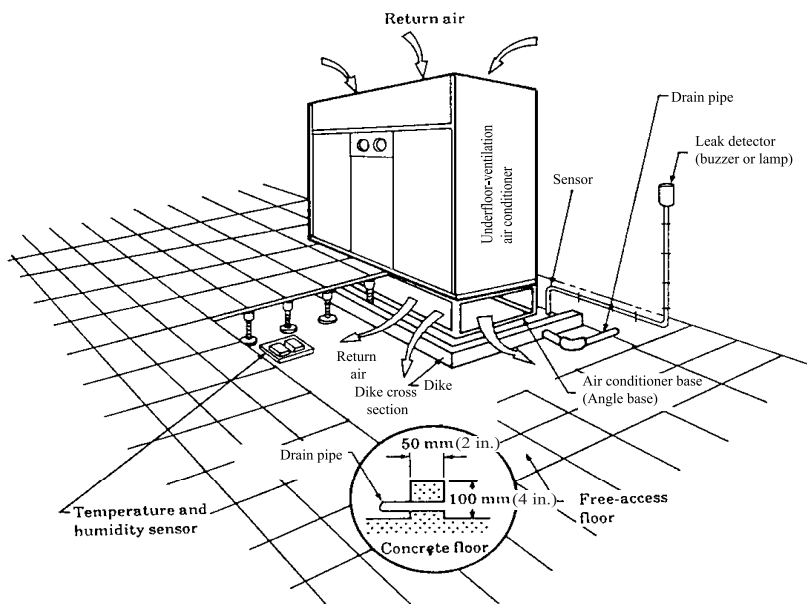

Figure 4.10 Dike

#### **4.5.7 Installing a backup unit**

It is recommended that the air conditioner be backed up. Without a backup unit, if the air conditioner fails, the resultant rise in the computer room temperature would demand a shutdown of the server system to correct the failure. A backup unit also facilitates scheduled inspections.

#### **4.5.8 Preventing freezing of cooling water**

The air conditioner for a server system is generally run for cooling year round. If a water-cooled air conditioner is used, care should be taken to prevent the water in the cooling tower from freezing.



# CHAPTER 5 Electromagnetic Environment and Static Electricity

This chapter explains the electromagnetic environment conditions and electrostatic effects relevant to server systems.

## 5.1 Magnetic Fields

CRT displays could be influenced by the magnetic fields generated by nearby power transformers, electric wires carrying large current, or any magnetized metallic objects.

### 5.1.1 Allowable magnetic field intensities of displays

CRT displays vary in allowable magnetic field intensity depending on the size of the CRT, resolution, etc.

Typical values are:

- Allowable AC magnetic field intensity: About 1  $\mu\text{T}$
- Allowable DC magnetic field intensity: About 50  $\mu\text{T}$  to 60  $\mu\text{T}$

## 5.1.2 Sources of magnetic fields and fault symptoms

Table 5.1 lists the possible sources of magnetic fields and the associated display screen faults.

Table 5.1 Sources of magnetic fields and fault symptoms (1/2)

Magnetic field component	Source of magnetic field	Fault symptom
AC magnetic field components	1 Power supply facilities, such as an uninterruptible power supply and a transformer, or any electrically driven equipment, such as a motor: Magnetic fields are generated by current flowing through the equipment. Example: AC magnetic field of 8.2 $\mu\text{T}$ at a point 4 m (13 ft) away from a transformer rated at 100 kVA.	Fluctuating display images
	2 Indoor electrical connections: A separation of 2 m (7 ft) from connections rated at 30 A or so will eliminate their effects. Example: AC magnetic field of 2.5 $\mu\text{T}$ at a point 1 m (3 ft) away from a connection that is not enclosed in a steel pipe.	
	3 High-voltage transmission lines, electric car overhead lines Example: A high-voltage transmission line rated at about 280 A will affect the display images of displays installed 5 m (16 ft) away with a magnetic field of 2.4 $\mu\text{T}$ , but will not affect those of a display device installed 10 m (33 ft) away with only 0.6 $\mu\text{T}$	
	4 Adjacent equipment: Magnetic fields generated from the adjacent equipment could exert adverse effects. Example: AC magnetic field of 3 $\mu\text{T}$ at a point 200 mm (8 in.) away from a display device.	
	5 Mutual interference among display devices: Magnetic fields generated from the deflection yoke in each device may have an interfering effect. Example: AC magnetic field of 3 $\mu\text{T}$ at a point 200 mm (8 in.) away from a display device.	

Table 5.1 Sources of magnetic fields and fault symptoms (2/2)

Magnetic field component	Source of magnetic field	Fault symptom
DC magnetic field components	1 Electrically welded metallic exterior sheets, etc.: Magnetism may remain as a result of metallic magnetization.	Color misconvergence, display distortion
	2 Magnets used in acoustic equipment: Speaker magnets, etc.	
	3 Steel-framed prefabricated columns, etc. moved by an electromagnetic on a crane Example: DC magnetic field of 100 $\mu$ T at a point 0.5 m (1.6 ft) away from the steel frame.	
	4 Equipment operating on a DC magnetic field principle, a magnetic paper holder, etc. Example: DC magnetic field of 500 $\mu$ T at a point 2 m (7 ft) away from a nuclear magnetic resonance unit	

### 5.1.3 Magnetic field control

Displays may require the following actions to control nearby magnetic fields in excess of their allowable magnetic field intensities:

#### (1) Separating the display

Keep the display farther away from sources of magnetic fields. Magnetic fields will be lessened in a range between the value divided by separation to the third power and the value divided by separation to the second power.

#### (2) Changing the display type

Change the display from a CRT display to a liquid-crystal or plasma display.

#### (3) Magnetic shielding

Special permalloy parts or cases can provide a shield against magnetic field effects. Certain display models are available with internal fitting magnetic shield options.

For information on magnetic shielding of a display as a whole, consult a shielding case manufacturer.

## 5.2 Electric Fields

This section describes electric fields.

### 5.2.1 Allowable electric field intensities for server systems

Each equipment has an allowable electric field intensity of 3 V/m, where 1 V/m is 120 dB/ $\mu$ V.

An electric field intensity of 1 V/m is a typical level encountered in a low-level electromagnetic radiation environment. For the example purpose:

- In transmissions from a typical radio or TV station located 1 km (3000 ft) away or farther
- In transmissions from a low-power transceiver

### 5.2.2 Conditions for using mobile phones

Keep the main unit doors closed and stay 1.7 m (5 ft) away from the main unit before using mobile phones.

Moreover, since mobile phones automatically emit electromagnetic waves in response to incoming messages, Fujitsu recommends keeping mobile phones switched off near the computing equipment.



## 5.3 Static Electricity

Static electricity may be charged and kept in a person's body by the following conditions.

- Through friction between shoes and floor as a result of his or her walking.
- Through friction between clothes and body.
- Also, carts may be charged as a result of their movement.

When this static electricity is discharged to server system at a high charge voltage, it could cause a malfunction. Hence, take steps to make the computer room less susceptible to electrostatic generation.

### 5.3.1 Recommended electrostatic voltage for a computer room

It is best if the static electricity charge on human bodies or carts be kept at such level or lower that there is no discomfort to the people when there is a discharge. For example it will not cause pain in the skin at discharge. This is variable from one individual to another, but it is generally about 2.0 kV (kilovolt). An electrostatic discharge of 2.0 kV or lower should not affect the server system.

### 5.3.2 Electrostatic control in the computer room

To inhibit the generation of static electricity, choose flooring that is rarely charged with static electricity and use humidity control. For computer room flooring surface materials, see [Table 2.3](#) For suggested computer room humidities, see [Table 4.1](#) and [Section 4.3.3, "Temperature and humidity recommendations for computer rooms."](#)



# CHAPTER 6 Power Supply Facilities

This chapter deals with input power requirements, power supply facilities, uninterruptible power supplies (UPS), grounding, distribution panels, distribution lines, and the share of responsibility for construction work.

Operational stability of a server system requires a good-quality power supply. Power supply facilities that match the power requirements of the server system must be selected to suit the importance of the server system's operation.

## 6.1 Input Power Requirements

This section describes input power requirements, power requirement, and a method for calculating rush current.

### 6.1.1 Input power requirements

Input power at the input power terminals of equipment must satisfy the requirements listed in [Table 6.1](#). For unit-specific input voltage, power requirement, and rush current specifications, refer to the relevant Installation Planning Manual.

Table 6.1 Input power requirement

Item	Requirement	
Input voltage	Number of phases	Abroad
	Single-phase two-wire	100 V, 110 V, 115 V, 120 V
	Single-phase two-wire	200 V, 208 V, 220 V, 230 V, 240 V
	Three-phase three-wire	200 V, 208 V, 220 V, 230 V, 240 V
	Three-phase four-wire	380 V, 400 V, 415 V neutral conductor connected to ground
Voltage regulation	From +10% to -10% of the input voltage or less	
Instantaneous input voltage variation	+15% to -20% of the input voltage or less in 0.5 second or shorter	
Instantaneous input interruption	1/2 cycle or less (10 ms or less at 50 Hz, 8.3 ms or less at 60 Hz)	
Input frequency	50 Hz or 60 Hz	
Frequency regulation	+2% to -4% of the input frequency	
Input voltage imbalance	5% or less (three-phase input)	
Voltage waveform distortion	10% or less	
Power capacitance	Depends on each unit specifications	
Rush current	Depends on each unit specifications	

### 6.1.2 Calculating the power required

For the purpose of selecting the kind of power supply facilities required, calculate the total power requirement of every unit in the system by consulting the relevant Installation Planning Manual.

### 6.1.3 Calculating the rush current

The rush current calculation assists with selecting a UPS. Calculate the rush current in the power-on sequence by consulting the documentation for each component. The case that more than one device may turn on at the same time should also be considered.

If the UPS is started up rapidly, the UPS startup could occur as rush current flows from the server system line filter and before the server system power controller begins to properly supply power to the server system. In this case, the UPS may detect overcurrent. Try to use an UPS that allows for a slow startup.

## 6.2 Power Supply Facilities

Select power supply facilities after considering the input power requirements of the server system (see [Section 6.1](#)), the availability of a power source at the installation site, and the operational importance of the server system.

### 6.2.1 Kinds and uses of power supply facilities

Power supply facilities are used for converting voltages, reducing leakage current, keeping a server system free from power failures, shaping waveforms, converting frequencies, and reducing harmonic currents.

[Table 6.2](#) lists the kinds of power supply facilities available, and their fitness for particular uses.

Table 6.2 Types of available power supply facilities and usage

Type of power supply facility	Use			
	Voltage conversion	Freedom from power failures	Waveform shaping	Reduction of harmonic current
Commercial power source	×	×	×	×
Transformer	O	×	×	×
UPS: Constant commercial type	×	O	×	×
UPS: Constant inverter type	O	O	O	O

Note: O means fit.

× means not fit.

Among the uses of power supply facilities, the reduction in leakage current and freedom from power failures are highlighted below.

## **(1) Reduction in leakage current**

Computers are equipped with a line filter in their power input terminals to absorb both external and internal electric noise. If a common commercial power source is connected to a computer, leakage current will flow to the grounding cable of the computer.

In a system built by connecting multiple computers with one another, the total leakage current flowing to ground across the system must be compliant with IEC60435 and IEC60364.

Notes:

Leakage current can be classified as follows:

- **Equipment leakage current:**

This equipment-inherent current is observed at equipment grounding terminals when power with the frequency/voltage characteristics of a commercial power supply is applied. The values of the current must be in accordance with the operating manuals for the respective equipment.

- **Ground leakage current:**

This current flows to ground in actual system operation, and it differs from the total equipment leakage current depending on the method of distribution line grounding. The floating current of the system has an effect on this current.

The rules of ground leakage current in the system must meet the rules of each country and be compliant with IEC60435 and IEC60364.

## **(2) Freedom from power failures**

Use of a UPS is recommended to keep the server system safe from power failures, instantaneous voltage drops, or instantaneous interruptions in the commercial power supply.

## 6.2.2 Selecting power supply facilities

Select power supply facilities to suit the available power source at the installation site, and the operational importance of the server system.

### (1) Systems that cannot tolerate service disruption

#### a) Power failure-free system

Use of a UPS is mandatory for server systems that cannot tolerate service disruption at any time even the instantaneous interruption or power failure of commercial power supply.

Figure 6.1 shows the configuration example of a server system which uses a UPS.

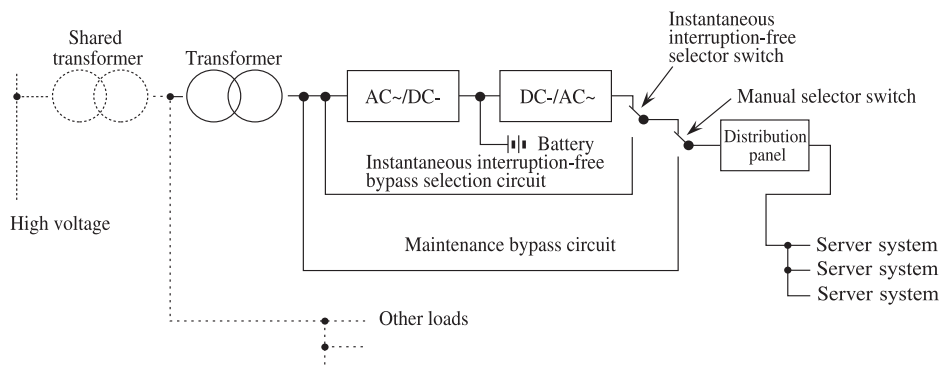

Note: Secondary side of UPS is isolated or neutral.

Figure 6.1 System based on a UPS

#### b) Long-duration power failure-free system

A UPS combined with an independent power generator provides a solution for longer term power failures as shown in Figure 6.2.

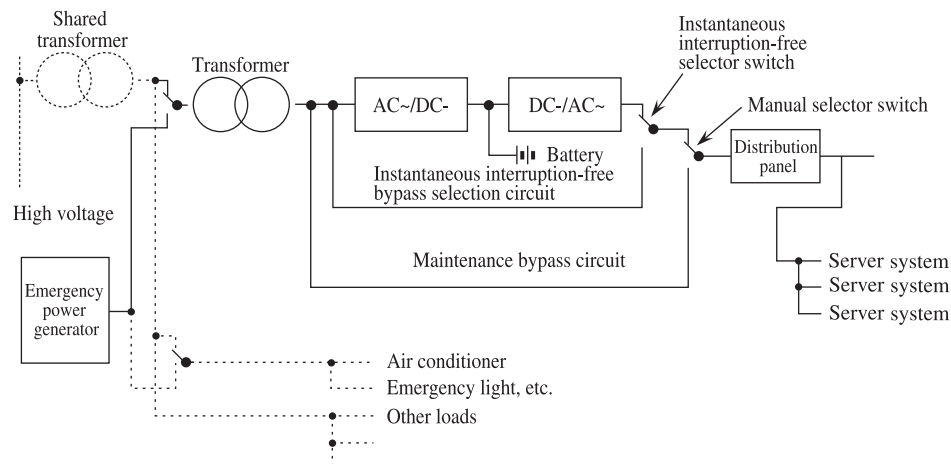

Figure 6.2 System based on a UPS and an independent power generator

## (2) Systems that can tolerate a service disruption

If a server system can tolerate a service disruption caused by power interruption or voltage variation, install a transformer dedicated to that system, isolated from the secondary terminals if the system runs at 200 V or grounded to a neutral phase wire if it runs at 400 V.

### a) Transformers dedicated to 200 V server systems

Table 6.3 contains descriptions of the types of transformers dedicated to 200 V server systems and their schematic views.

Table 6.3 Transformers for 200 V server systems

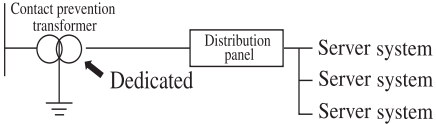
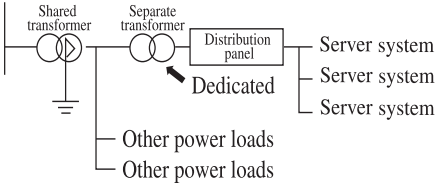
Case	Transformer dedicated to a server system	Schematic view
A dedicated high-to-low-voltage transformer can be installed.	Install a contact prevention transformer that has an output voltage of 200 V and is dedicated to the server system. The secondary terminal of the transformer shall be isolated.	<p>High-voltage line</p> 
High-to-low-voltage transformer that is shared with other power supplies.	Install a separate transformer that has an output voltage of 200 V and is dedicated to the server system near the distribution panel. The secondary terminal of the transformer shall be isolated.	<p>High-voltage line</p> 



## b) Transformers dedicated to 400 V server systems

Table 6.4 describes the types of high-to-low-voltage transformers that can be dedicated to 400 V server systems and those that can be shared with other power supplies.

Table 6.4 Transformers dedicated to 400 V server systems

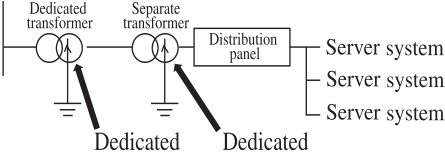
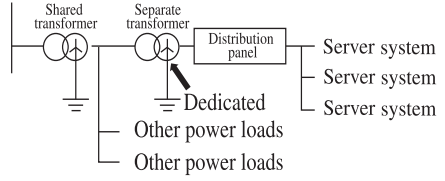
Case	Transformer dedicated to a server system	Schematic view
<p>A dedicated high-to-low-voltage transformer can be installed.</p>	<p>Install a transformer in the power receiving/transformer room. If the power receiving/transformer room is not close to the computer room, install a separate transformer near the distribution panel in the computer room. The secondary terminal of the separate transformer shall be grounded to a neutral phase wire.</p>	<p>High-voltage line</p> 
<p>A high-to-low-voltage transformer that is shared with other power supplies.</p>	<p>Install a separate transformer near the distribution panel in the computer room, with its secondary terminal grounded to a neutral phase wire.</p>	<p>High-voltage line</p> 

## 6.3 UPS Requirements

An Uninterruptible Power Supply system (UPS) supplies power to server systems constantly under power failures even in a huge magnitude of power failures.

Instantaneous voltage drop of commercial power generally occur by thunder. The chance of occurrence of instantaneous voltage drop depends on the location of the site (in Japan, three to four times in a year). The typical interruption time of power supply is said between 0.07 to 2 seconds.

Generally, power distribution circuits of server systems can maintain the performance under power interruption at magnitude of 0.01 second. When the lower power supply or power interruption sustains over 0.01 seconds, operation of server systems is disabled, and this may lead to system down. It is important to avoid instantaneous system down since longer time must be spent to reactivate the server systems, and applications may interrupt for long time accordingly. Not only that, important files may be destructed. Use UPS to prevent such instantaneous power failures. UPS distributes to components in the server system in operation by its built-in batteries under such interruption of commercial power supply.

UPS examination items are explained below.

Note that if the UPS is installed regardless of the following requirements, the requirements of the server system and the performance of the UPS mismatch, and the user's server system may be damaged, or significant data may be destroyed.

- [UPS load specifications](#)
- [Prediction of rush current and load variation of the equipment](#)
- [UPS terminating requirements](#)
- [Effect of high-frequency noise](#)
- [Life-span of a UPS built-in battery](#)
- [Discharge of UPS built in battery](#)
- [Requirements for power interruption](#)
- [Leakage current](#)
- [Load rating](#)
- [Power rating \(for printer connection\)](#)
- [Checking the UPS environmental specifications and the warranty term](#)

## (1) UPS load specifications

Some server systems adopt condenser-input type rectifier circuit (commutating load) as shown in [Figure 6.3](#).

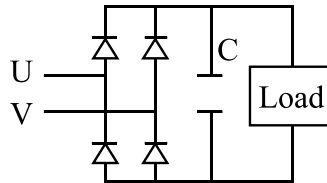

Figure 6.3 Commutating load circuit

Rectifier of this type turns the current waveform of a server system into a distorted waveform containing harmonics. The amplified crest (peak value) of distorted waveform containing harmonics is about 2.8 times to the effective value. (It means that if effective value is 10 A, the peak value is 28 A.) If the UPS is so designed that output voltage is regulated by resistor, driving at 50% or less of the UPS's deliverable output voltage is needed. Make sure that the rectifier has a mechanism that lowers the distortion (peak value is about 2.8 times) current passing the rectifier to 10% (distortion factor) at peak wave (crest factor). Also check this point for loads of transformers and motors (linear amplifier).

As the conclusion, the recommendable UPS rectifier load specification is:

- Linear load or Peak-to-valley ratio (at peak) must not exceed 2.8

## (2) Prediction of rush current and load variation of the equipment

Turning on the power to connected devices generates rush current. For example, a component operating at a steady-state current of 3 A may generate a current of 30 A<sup>0-P</sup> when it is turned on. Even when connected devices generate rush current, the UPS output voltage fluctuation must stay within  $\pm 15\%$ . Special attention must be paid to cases where multiple devices are connected, since the rush current generated by each connected device at its power-on time may cause a UPS voltage drop, and other components in operation may stop operating. Therefore, the rush current and load variability of the components must be reviewed together with the overcurrent detection specifications of the UPS.

### **(3) UPS terminating requirements**

UPS terminates when incorrect current is loaded (overload). When such circumstance is made, the output cutoff circuit (which prevents distribution of current exceeding the specification) activates to drop voltage, and the UPS stops. Some components may generate higher load to stop UPS. If this occurs, input power to the components is switched to direct commercial power since UPS stops when overloaded. As switching back input power to UPS, rush current is generated, then UPS stops again. As such, power supply can not be steady. To avoid this, review the specified overload value that UPS activates the circuit (the mean and peak values), and make sure to operate under the value.

### **(4) Effect of high-frequency noise**

Normally, UPS uses microwave switching method. For this reason, output noise and input noise around the components and reflection noise are generated. These noises may cause components failure and data destruction of the nearby recording media.

Therefore, following must be reviewed when selecting a UPS.

- Input and output noise around the component is 4 V<sup>P-P</sup> or less
- Reflection noise is 70 dB or less
- Do not place magnetic tapes and floppy disks on the UPS

### **(5) Life-span of a UPS built-in battery**

The main type of battery built into a UPS is a lead-acid battery. Lead-acid batteries have their own life-spans, and therefore Fujitsu recommends a service support agreement for immediate battery replacement.

### **(6) Discharge of UPS built in battery**

Once a lead-acid battery is completely discharged, sufficient voltage cannot be generated even when recharged. If this occurs, replace the battery. The battery in a UPS that supplies its control power from the battery may be in the discharged state if left on but not used for about five days because a power failure occurred or because it was in storage. To prevent this, the battery switch must be turned off when the UPS is not in use. Some UPSs automatically turn off the battery switch when they stop operating.

## (7) Requirements for power interruption

The following specifications must be checked for selection of a UPS.

- Most of UPS cannot be started up under circumstance of power interruption. If such startup is required, request the UPS manufacturer for modification.
- When part of system components are connected to UPS, and the rest of the components are connected directly to the commercial power, the components connected to commercial power supply may generate incorrect signals, and the components malfunction may occur.

## (8) Leakage current

If commercial power supply facilities have leakage shut-off unit, leak current from a UPS may activate the shut-off unit. In such case, the following actions must be considered.

- Increase the trigger voltage of the shut-off unit.
- Use a shut-off unit which does not trip easily by microwave leakage current.
- Install an insulation transformer between the UPS and the commercial power outlet.

## (9) Load rating

When operating UPS in higher power factor than its rated power factor, use the UPS in reduced output voltage. For example, a rating power factor of a 10 kVA/8 kW rated UPS is 0.8.

$$\frac{8 \text{ kW}}{10 \text{ kVA}} = 0.8$$

When connecting load lower than 0.8 power factor to the UPS, up to 10 kVA load can be connected. When connecting load greater than 0.8 power factor, reduce the load to the calculated value by the formula below.

$$\frac{8 \text{ kW}}{\text{power factor of load}} = \text{load}[\text{kVA}]$$

**(10) Power rating (for printer connection)**

If a printer is connected to a UPS, selecting a UPS whose power capacitance is sufficient to connect a printer is needed, by taking account of the following precautions.

- Input voltage variation of a printer depends on the printing mode.
- Some laser printers requires few times higher than their rated power in toner fixing.

**(11) Checking the UPS environmental specifications and the warranty term**

Other precautions and requirements:

- UPS environmental specification
  - Input capacity
  - Grounding phase in input one-line grounding
  - External dimensions
  - Mass
  - Amount of heat dissipation
  - Earthquake-proofing actions
  - Noise level
  - Input/output terminals (connector)
- Warranty term

## 6.4 Grounding

Grounding should be planned to suit the following:

- [Grounding equipment in the computer room](#)
- [Grounding other equipment](#)
- [Grounding LAN devices](#)
- [Grounding-plate method](#)
- Grounding of surge absorbers

For the last, see [Chapter 7, "Protection Against Lightning."](#)

### 6.4.1 Grounding equipment in the computer room

For grounding equipment, connect a protective grounding conductor to the dedicated grounding electrode.

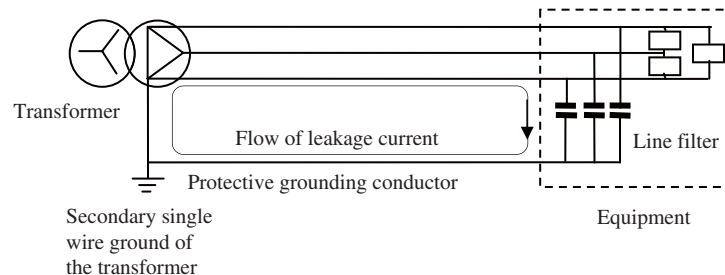

Figure 6.4 Method of grounding equipment

If possible, do not connect an equipment cabinet to the ground built into the floor of the computer room (such as a mesh ground) through a separate wire. This could cause stray current to flow into the system and cause a malfunction.

The grounding method for the server systems depends on whether the computer room is in a building that conforms to the Grounding Regulation Types or the International Electrotechnical Commission (IEC) standards.

#### (1) Grounding in the buildings in conformance with the Grounding Type:

The grounding conditions for the server systems to be installed in the domestic or others' buildings which are in conformance with the Grounding Type with A to D type are as follows:

To run the server systems in the computer room stable, the dedicated grounding cable facility must be prepared for each server system to prevent extraneous noise coming from the distribution line or other grounding system lines.

The grounding cable facilities to be installed in the computer room must have dedicated grounding electrode. Primarily, the wiring from the dedicated grounding electrode through the distribution panel in the computer rooms must be implemented by the metal conduit installation method using the special insulated cables. This ground wiring facility must not be shared with other facilities.

The grounding resistance of the dedicated grounding electrode and the grounding trunk cable must be as follows:

- Grounding resistance of the dedicated grounding electrode: 10  $\Omega$  or less
- Size of the grounding trunk cable: 22 mm<sup>2</sup> (AWG 4) or more

## (2) Grounding in the buildings conforming with the IEC standards.

In the installation of server systems to the buildings based on the equal potential bonding principal of the IEC standards, the server systems must be grounded using grounding facility shared with other facilities.

Because the ground is not the dedicated one, the grounding trunk cables for the server systems are preferably branched from the grounding box near the grounding electrode (the main grounding terminal).

If there is no way other than branching from the omnibus grounding cable nearest to the server systems, please consult with Fujitsu Facility section because noise countermeasure which requires expertise is required in most cases.

Primarily, the wiring of grounding trunk cable must be implemented by the metal conduit installation method using special insulated cables. Follow [Table 6.5](#) for the cable size.

Table 6.5 Specification of the grounding trunk cable for server systems  
(in the buildings complying to the IEC standards)

Cross section of the phase conductor of the facilities $S$ (mm <sup>2</sup> )	Minimum cross section of the grounding trunk cable $S_p$ (mm <sup>2</sup> )
$S \leq 16$ (AWG5)	$S$
$16$ (AWG5) < $S \leq 35$ (AWG2)	$16$ (AWG5)
$S > 35$ (AWG2)	$S/2$

Note: The term "the phase conductor of the facilities" represents a conductor of a phase of a power supply cable which is led into the distribution panel.



## 6.4.2 Grounding other equipment

Table 6.6 summarizes the requirements for other equipment grounding facilities.

Table 6.6 Requirements for other equipment grounding facilities

Item	Requirements
Grounding electrode	<ul style="list-style-type: none"> <li>• A dedicated grounding electrode for other equipment is recommended. If a dedicated grounding electrode is not available, a grounding trunk cable may be branched from a shared grounding electrode.</li> <li>• The grounding resistance must not exceed 100 <math>\Omega</math>.</li> <li>• Keep the grounding electrode at least 10 m (33 ft) apart from the lightning arrester grounding electrode.</li> </ul>
Grounding trunk cable	<ul style="list-style-type: none"> <li>• Use an insulated wire at least 5.5 mm<sup>2</sup> (AWG10).</li> <li>• Use the grounding trunk cable dedicated to other equipment. Do not share with other facilities.</li> </ul>
Distribution panel grounding terminal	<ul style="list-style-type: none"> <li>• Isolate the primary grounding terminal and branch grounding terminals for other equipment from the distribution panel frame.</li> </ul>

### 6.4.3 Grounding LAN devices

Grounding LAN devices which share the same signal ground to the same grounding system and those which have different signal ground to different grounding systems.

The method for grounding LAN devices, details of the separation of the LAN transmission line signal ground from the connected devices, and typical modes of LAN connection and grounding are described below.

#### (1) Grounding LAN devices

The signal ground of each device signal line is separated at the point of connection with the LAN transmission line for both optical and metal cables.

A coaxial cable transmission line must be grounded at one point per segment.

LAN devices may be grounded to different grounding systems individually or in groups.

A group of devices connected to the same transceiver must be grounded to the same grounding system.

#### (2) Separation of the LAN transmission line signal ground from the connected devices

The LAN transmission line signal ground is separated from the ground of the connected devices. [Table 6.7](#) details the separation of the signal ground.

Table 6.7 Details of the separation of the LAN transmission line signal ground (SG)

Transmission line	Cable type	Details
Fibre	Optical fibre	Separation by opto-electrical and electrical-opto-signal converters
10Gigabit Ether	Optical fibre	
Gigabit Ether	Optical fibre	
FDDI	Optical fibre	
100BASE-T	Paired	Separation by transceiver's signal transformer
Gigabit Ether	Optical fibre	

#### (3) Typical modes of LAN connection and grounding

Typical LAN connections and grounding are described below with regard to 100Base-T.

[Figure 6.5](#) shows a typical 100Base-T connection. The transmission route of a twisted pair cable is not to be grounded.

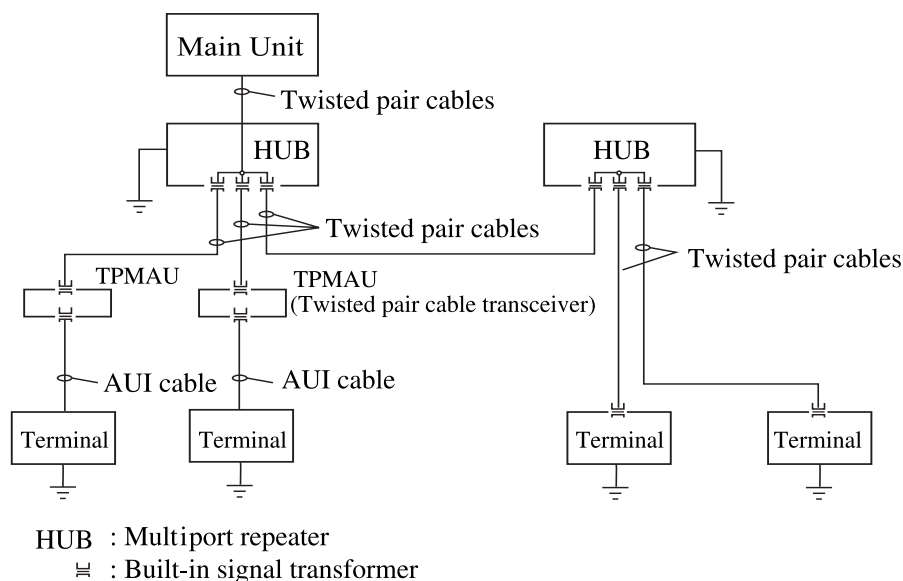

Figure 6.5 Typical 100 Base-T connection

#### 6.4.4 Grounding-plate method

In shared ground facilities complying with the International Electrotechnical Commission (IEC) standards, noise generated by other electronic facilities such as electronic devices, air conditioning facilities and elevators may penetrate the server systems through the shared ground facilities' cables. In some cases, this can be prevented by the grounding-plate method. In the grounding-plate method, a grounding plate (see note below) is laid under the raised floor near the power distribution panel, as shown in [Figure 6.6](#). This reduces electrical noise from other equipment. For whether the site requires implementation of grounding-plate, consult with the Facility section.

Note: Grounding-plate conducts by high-capacitance conductive sheet covering over copper plate.

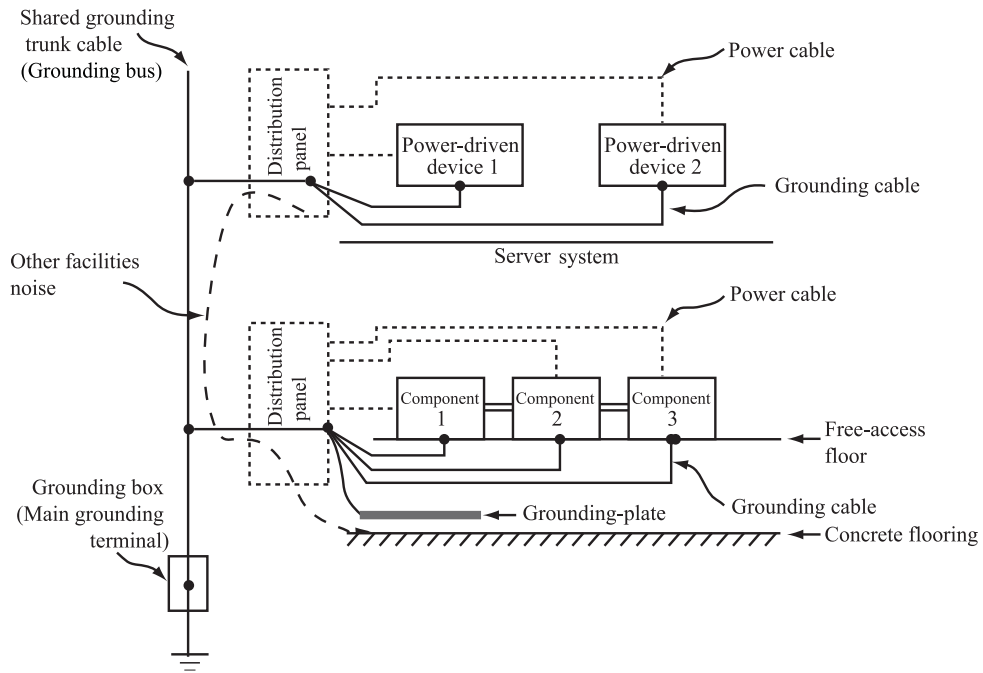

Figure 6.6 Grounding-plate method

## **6.5 Distribution Panels**

This section describes distribution panels.

### **6.5.1 Distribution panel location**

#### **(1) Computer room distribution panel**

A distribution panel must be installed in the computer room to distribute power to the server system components.

#### **(2) Location**

The distribution panel must be located near the entrance and where it will not interfere with operation.

#### **(3) Distribution panels for a larger system**

For a larger system, distribution panels installed at several points in the room is recommended.

### **6.5.2 Distribution panel breakers**

A circuit breaker must be used in each branch circuit in the distribution panel. Information about the number of branch circuits and circuit breaker capacitance is available from Fujitsu.

A UPS over-current alarm could be issued if many components are turned on at the same time. As such, sequential startup using multiple distribution panels is recommended.

### 6.5.3 Distribution panel structure

A distribution panel uses an output terminal strip to connect a power cable to each device. [Figure 6.7](#) and [Figure 6.8](#) show typical distribution panel setups having output terminal boards.

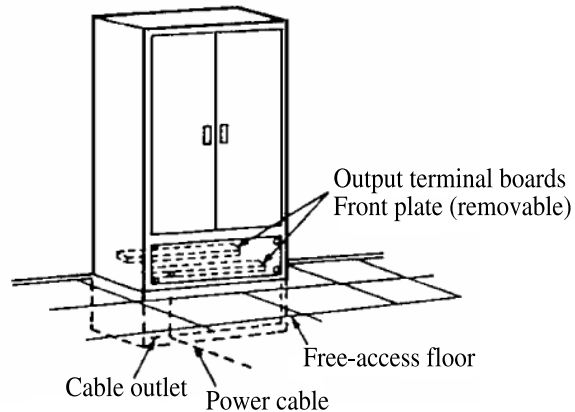

Figure 6.7 Distribution panel (free-standing)

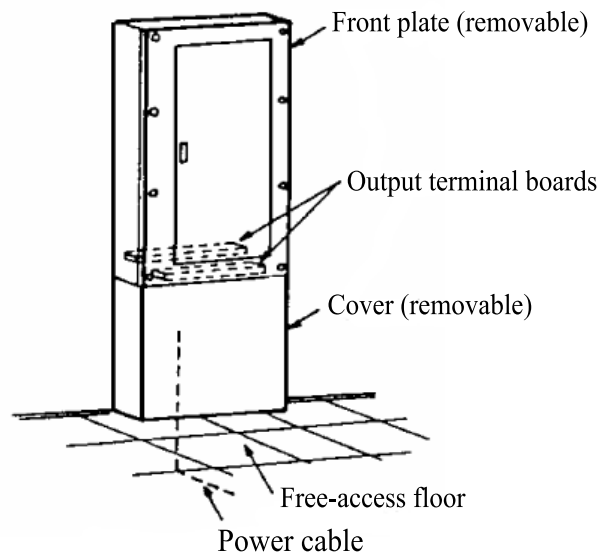

Figure 6.8 Distribution panel (wall-mounted)

The distribution panel structures and output terminal boards are described below:

#### (1) Output terminal board position

Normally, breakers are in the upper part of the distribution panel, and output terminal boards are in the lower part so that connecting cables can be easily drawn from the output terminal boards to under the free-access floor.

## (2) Distribution panel front plate

The front plate must be removable to allow for cable connection to the output terminal boards.

## (3) Connected device marking

A card holder is provided near each breaker to indicate the name of the associated device.

## (4) Output terminal boards requirements

The following list is output terminal board requirements:

- Round crimp terminals must be connectable.
- Screws should have a nominal metric screw head designation of M6, M8, or M10.
- The correspondence between breakers and output terminal boards must be identifiable.
- The current rating of each output terminal board must be associated with the corresponding breaker.
- Output terminal boards must have the dimensions listed in [Table 6.8](#).

Table 6.8 Output terminal board dimensions

Breaker rating	Output terminal board dimensions	Round crimp terminal dimensions					
		L		W		d $\phi$	
		mm	in.	mm	in.	mm	in.
100 A	Round crimp terminal R38-10 is connectable	41.5	1.634	22	0.866	10.3	0.406
75 A	Round crimp terminal R22-8 is connectable	33	1.299	16.5	0.650	8.3	0.327
50 A	Round crimp terminal R14-6 is connectable	29.5	1.161	12	0.472	6.7	0.264
30 A	Round crimp terminal R8-6 is connectable	23.5	0.925	12	0.472	6.7	0.264
20 A	Round crimp terminal R8-6 is connectable	23.5	0.925	12	0.472	6.7	0.264

Round crimp terminal dimensions L, W, and  $d \phi$  are shown in Figure 6.9.

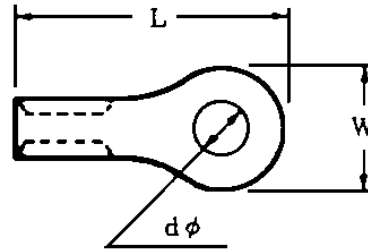

Figure 6.9 Round crimp terminal dimensions

### (5) Space around output terminal boards

The space around output terminal boards must meet the requirements illustrated in Figure 6.10.

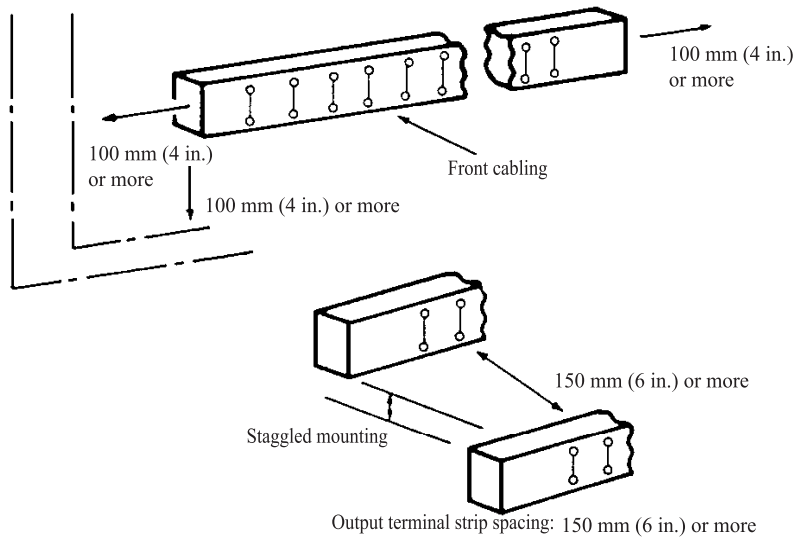

Figure 6.10 Space around output terminal boards



## (6) Grounding connection within a distribution panel

Figure 6.11 shows grounding connections within a distribution panel.

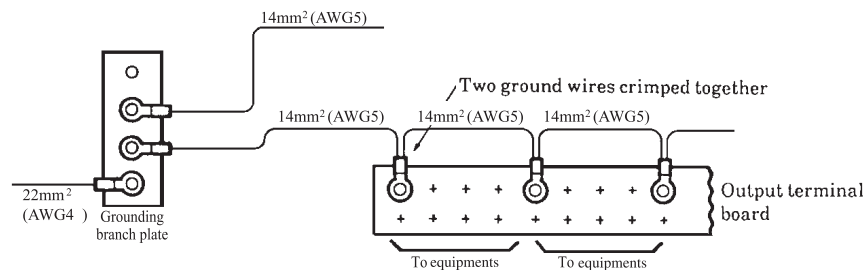

Figure 6.11 Grounding connections within a distribution panel

## 6.6 Distribution Lines

The construction of distribution lines requires consideration of induced noise control and voltage drops.

### 6.6.1 Induced noise control

#### (1) Distribution line to the distribution panel

A cable enclosed in a metal conduit or a copper- or iron-shielded cable must be used for the distribution line between power supply facilities and the distribution panel in order to protect the cable against noise induced from other distribution lines. Alternatively, use a dedicated shaft to isolate the distribution line from other lines.

#### (2) Distribution line to power supply facilities

A cable enclosed in a metal conduit or a copper- or iron-shielded cable should be used for the distribution line between a transformer and power supply facilities, such as an uninterruptible power supply (UPS), to allow for switching to direct distribution in times of power supply facility failures or during inspection.

## 6.7 Share of Responsibility for Construction in a Computer Room

The share of responsibility for construction are :

- Fujitsu will install wiring from the output terminal block in the distribution panel to individual devices in the same room as a standard construction. The construction of all other electrical requirements is the user's responsibility.
- The user is responsible for electrical wiring and receptacle for devices.

Figure 6.12 shows the share of responsibility for construction in the computer room.

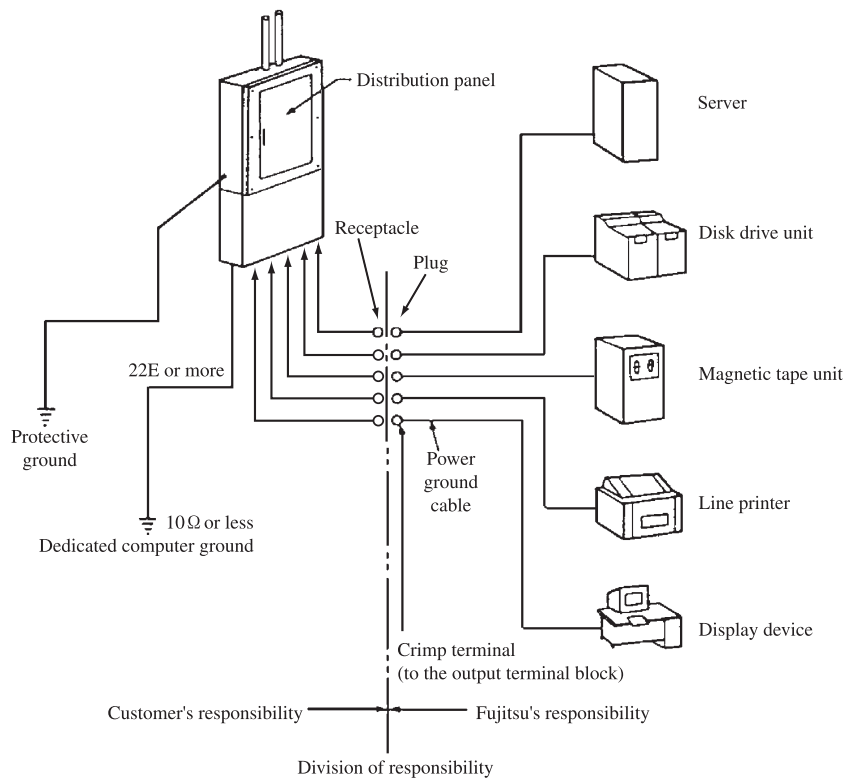

Figure 6.12 Share of responsibility for construction in a computer room

## 6.8 Distribution Line Insulation Testing

This section specifies the test voltage for distribution line insulation testing and explains the points to watch when performing phase and grounding cable insulation tests and interphase insulation tests.

### 6.8.1 Test voltage

Use an applied test voltage within DC250 V for distribution line insulation testing.

### 6.8.2 Phase and grounding cable insulation test

Perform an insulation test with each phase of the distribution line and the grounding cable for the following conditions:

- On the distribution line from the distribution panel to each device, keep the device's power cable connected (directly connected to the distribution panel or plugged into an outlet).
- Leave devices off.

To avoid damage to server systems, interphase insulation testing should not be conducted in these conditions.

### 6.8.3 Interphase insulation testing

Interphase insulation testing is required only for new distribution lines and can be bypassed in subsequent scheduled inspections.

When performing interphase insulation testing, take notice of the following precautions:

#### (1) Interphase insulation test within the distribution panel

Turn off all the breakers for the server system to perform an interphase insulation test within the panel.

To avoid server system failures, do not apply a test voltage between different phases of the device power cable.

## **(2) Interphase insulation test from the distribution panel to a directly connected device**

An interphase insulation test may not be performed on a power cable that directly connects a device to the distribution panel. If interphase insulation testing of a direct power cable is required, disconnect the device and power cable from each other. Also turn off the corresponding breaker to prevent the test voltage from being applied to devices attached to any other breaker line.

Users who wish to disconnect power cables for testing should check with the certified service engineer, because the power cables will require subsequent reconnection and confirmation.

## **(3) Interphase insulation test of the distribution network**

Perform an insulation test between the distribution panel and each outlet. First unplug all server system power cables associated with that breaker line.

Turn off the corresponding breaker in the distribution panel to prevent the test voltage from being applied to devices attached to any other breaker line.

# CHAPTER 7 Protection Against Lightning

If a low-voltage distribution cable that feeds power directly to devices or an interface cable is to be laid outdoors, safeguards are needed to protect against possible destruction caused by lightning surges.

If a device is damaged by a lightning, the direct cause is a surge (abnormal voltages and currents). Lightning surges can be classified into four cases:

- 1 Direct inflow of current into cables or devices caused by a direct lightning strike to the cable or device or by a lightning strike to the ground.
- 2 Generation of a surge voltage or current resulting from a large ground potential difference between devices caused by lightning near any one of these devices or any interconnecting cable.
- 3 The induction of a current surge through a cable resulting from lightning near the cable.
- 4 The release of charge which has been captured by thunder cloud and accumulated on a cable, and which flows as a surge.

Generally, the phenomena outlined 1 and 2 are called direct strikes, while those outlined in 3 and 4 are called indirect strikes. Direct strikes have such a huge destructive energy that protection against them is extremely difficult to achieve. Indirect strikes, on the other hand, have by far a less destructive energy, and surge absorbers will usually provide protection against them.

Protection, however, will not be available against surges that are beyond the performance limits of the surge absorbers.

## 7.1 Protection of AC Line

The surge protection level of SPARC Enterprise and PRIMEQUEST power supply facility complies to the International Electrotechnical Commission (IEC) standard. Therefore, special protective action against typical multitude of lightning is not required. However, depending on the multitude of induced surge energy, the equipment may be damaged by the induced surge. Especially in some regions where often encounter thunder, implementation of external surge absorber is recommended.

The preventive action on AC lines for surge attacks can be classified into following three methods:

- [Using power control box \(F9710PW2\)](#)
- [Install a surge absorber in each terminal outlet](#)
- [Install a surge absorber to the input side of a distribution panel](#)

The procedure for each method is described below.

### (1) Using power control box (F9710PW2)

F9710PW2 power control box is effective for the components connected through Switched/Unswitched type outlet. If power consumption sum of the components is lower than 1.5 kVA, install the power control box between the processing components and the power supply facility (connect the power cable of the processing component with Unswitched outlet of the power control box). This control action protects the processing components from surge voltage.

[Table 7.1](#) shows the specification of the power control box (F9710PW2).

Table 7.1 Specification of power control box (F9710PW2)

Item		Specification
Rated voltage		AC100V $\pm$ 10%
Rated capacity		1.5 kVA (15 A/phase) (Unswitched+Switched)
Serving outlets	Unswitched	2 outlets, 2P + ground type
	Switched	4 outlets, 2P + ground type
For control signal		2 m (7 ft), Mini DIN8P (Controlled by PC interface)
For input power		3 m (10 ft), 2P + ground

## (2) Install a surge absorber in each terminal outlet

Figure 7.1 shows the surge absorber connected to commercial power outlet. This type is dedicated to single terminal. Applicable for all components using commercial power outlet.

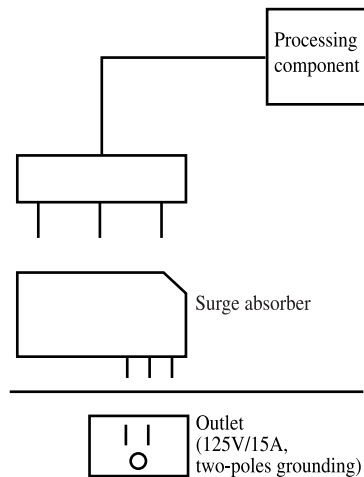

Figure 7.1 Surge absorber (power outlet connected type)

## (3) Install a surge absorber to the input side of a distribution panel

Figure 7.2 shows the surge absorber installed on the input side of distribution panel. All server systems in a group connected to the surge absorber mounted input line can be protected.

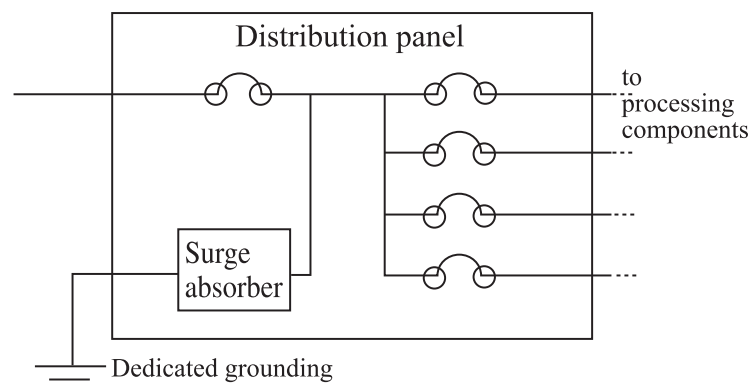

Figure 7.2 Install surge absorber on the distribution panel's input side

## 7.2 Protection of Signal Lines

### (1) External modem is in use

When modems are installed, damage to internal circuitry components in the modems could result from indirect strike surges. Hence, it is recommended to install the appropriate surge absorber.

Some modems are equipped with surge absorber within them. If modems are installed, and the modem does not have surge absorber, installation of an external surge absorber should be considered. [Figure 7.3](#) lists recommended surge absorber.

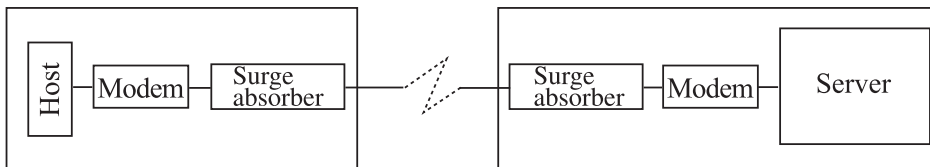

Figure 7.3 Lighting control action when using external modem

[Table 7.2](#) shows the recommended surge absorber.

Table 7.2 Recommended surge absorber for external modem

Model	Manufacture
FPZ-100-2	—

### (2) LAN connection

For the connection of outdoor LAN, optical cable should be applied as shown in [Figure 7.4](#) below.

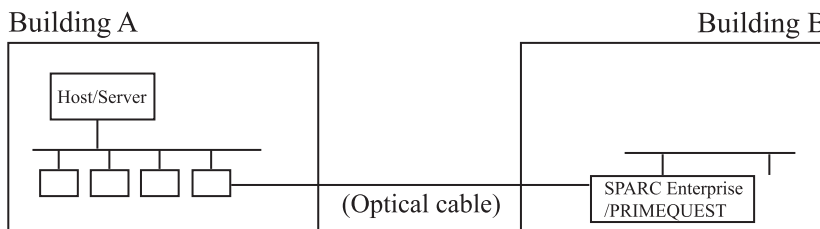

Figure 7.4 Lighting control action for LAN cables



# CHAPTER 8 Security Actions

With more sophisticated and extensive use of servers, concern over the security of server systems has become increasingly important. In an online application, for example, a disruption of the central system would degrade or shut down the functionality of the terminals, which could have social or economic consequences depending on the nature of the application. Alteration, loss, or theft of data can be considered an infringement on a person's property or privacy.

Thus, the security of a server system is of foremost importance and a security system should be implemented to match the users' requirements based on their objectives for using the server system, and other relevant characteristics including the economic and social status of the users. This chapter describes the basic concepts involved in security system.

## 8.1 Basic Concepts

This section discusses levels of security, objects of security, and the kinds of problems that can be anticipated.

### 8.1.1 Levels of security

The implementation of security begins by deciding on the level of security required, or to what extent security must be ensured. This is usually done by examining a number of security levels and choosing one as the most appropriate. The security level should be tailored to suit the users' particular needs. A general example of security levels is given below:

1 Even if a disaster occurs, services can successfully continue.

The highest level of security which requires extensive technical and economic discussions.

- 2 If a disaster occurs, services are closed down, but can be resumed immediately when the disaster is over.  
Services are closed down temporarily to protect against errors or malfunctions that might arise from continuing to run the server system for the duration of the disaster, or from problems in running associated facilities. This level assumes no physical or qualitative damage will be incurred.
- 3 Certain damage may be caused by a disaster but recovery can be effected and services resumed in a short time.  
Services are closed down for the duration of the disaster, and some qualitative damage will be incurred.
- 4 Sizable damage is incurred, and time is required for recovery.  
The server system outage is tolerable as its effects may be limited to particular applications.
- 5 Destructive damage is incurred, with no or little hope of recovery.  
Security level is 0. This situation should be avoided by all means.

### 8.1.2 Objects of security

It is necessary to define the objects of security and consider the actions needed to suit each. The following list is general objects of security:

- Human beings
- Buildings
- Computer rooms
- Data warehouses
- Power supply rooms
- Air conditioning rooms
- Server systems
- Power supply facilities
- Air conditioners
- Storage media
- Documentation
- Furniture and fixtures
- Pipes, ducts, lighting fixtures, etc.

---

### 8.1.3 Kinds of disasters

Different kinds of disasters require different security actions suited to their causes and characteristics.

- Fires  
Negligence, leaks, catching fire from flare, arson, etc.
- Earthquakes  
Overturns, falls, movement, breakage, etc.
- Water damage  
Floods, rainwater leaks, supply/drainage pipe leaks, leaks from facilities which use water, water for extinguishing fires, etc.
- Subversive activities, theft, obstructive activities, etc.  
Demolition, robbery, break-in, server system infiltration, occupation, threat, harassment, mischief, etc.

## 8.2 Details

This section describes some specific security precautions that can be taken for each disaster type.

### 8.2.1 Fire

Fires could bring about serious damage and there should be adequate precautions for fire protection. Fire prevention, evaluation, fire extinguishing, and clean up require appropriate precautions and preparation.

The most important precaution in fire control is to prevent a fire from starting. To this end, thorough fire prevention control is required. Examples of actions to prevent fires are:

- Prohibit handling of fire except in a designated area, and limit the presence of inflammable substances.
- Store waste paper in metal containers, and empty them regularly.
- Use furniture and fixtures made of nonflammable material.
- Use nonflammable interior materials.
- Keep things neat and in order.
- Appoint people to conduct periodic inspections.

It is also important to train and prepare staff to fight fires before they become too serious.

While the Fire Services Law and other relevant regulations dictate that certain fire-fighting equipment be available, this equipment is not necessarily adequate for server system security. The installation of more appropriate fire-fighting equipment is recommended, even if they are not required by these laws and regulations.

### (1) Automatic fire alarms

Keeping human guards to constantly monitor for fires provides the best protection, however this is not always practicable at night or during holidays. Further, full monitoring may not be possible even if guards are available. Automatic fire alarms are useful in these situations. Computer rooms and data storage rooms should each be designated as independent alarm zones (see [Figure 8.1](#)).

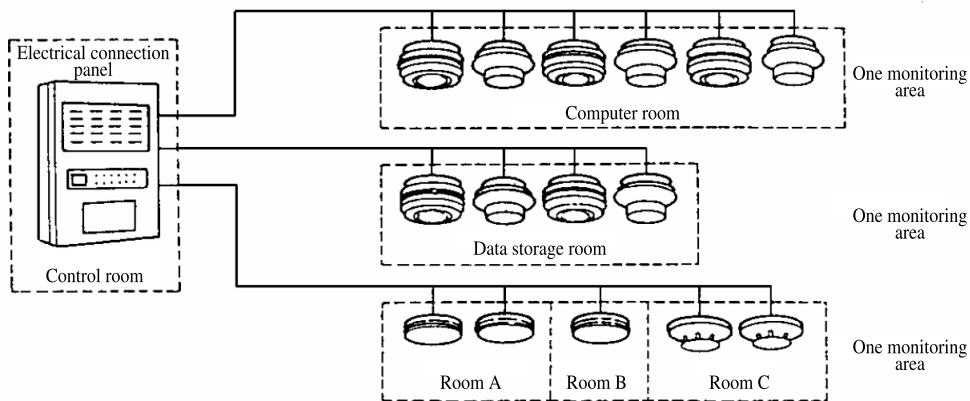

Figure 8.1 Designating alarm zones

An alarm zone is an area in which a single line of an automatic fire alarm is capable of detecting fires. An independent alarm zone may not exceed 600 m<sup>2</sup> (6460 ft<sup>2</sup>) in area, with the length of each side not exceeding 50 m (160 ft), and may not span two or more floors. If the computer room exceeds these limits, it must be split into two or more alarm zones.

For fire-resistant building, automatic fire alarm sensors should be installed on the finished surface of the ceiling. In the computer room, sensors should also be installed under the free-access floor, and also in the ceiling if return air from the air conditioner passes through the ceiling.

It is also recommended that smoke sensors that operate on both an ion and photoelectric principle be installed in the computer room and the data storage room.

## (2) Kinds of fire extinguishing agents

Ideally, any fire extinguishing agents to be used in the computer room and the data storage room should not contaminate the equipment or storage media, be harmless to the human body, and be environmentally friendly.

Table 8.1 lists fire extinguishing agents and their characteristics.

Table 8.1 Characteristics of fire extinguishing agents

Fire extinguishing agent	Characteristics
Carbon dioxide	Carbon dioxide will not contaminate devices or media but it does require care to avoid human suffocation. Also when sprayed, it can turn into a white mist or condense on equipment surfaces due to its low-temperature.
Halon gas	Use of halon gas should be avoided, since it leads to contamination of the ozone layer.
Powder and foam	Use of powder and foam should be avoided, since it contaminates equipment and mediums.
Water	Water is not suitable for extinguishing electrical fires in their early stages, but may be required for extinguishing larger fires.

## (3) Fire extinguishers and fire extinguishing equipment

Fire extinguishers and fire extinguishing equipment that is installed in the computer room and the data storage room are described below.

### a) Portable fire extinguishers

Portable fire extinguishers are used to extinguish fires in their early stages. Use of gas-based fire extinguishers or carbon dioxide fire extinguishers is recommended. Care must be exercised, however, in using carbon dioxide fire extinguishers to avoid oxygen deficiency or suffocation.

The number of portable carbon dioxide fire extinguishers that needs to be installed by room size is as follows:

- Rooms measuring from 20 m<sup>2</sup> to 50 m<sup>2</sup> (220 ft<sup>2</sup> to 540 ft<sup>2</sup>)  
One portable carbon dioxide fire extinguisher filled with 3.2 kg (7.0 lb) of carbon dioxide per room.
- Rooms measuring from 50 m<sup>2</sup> to 100 m<sup>2</sup> (540 ft<sup>2</sup> to 1080 ft<sup>2</sup>)  
Two portable carbon dioxide fire extinguishers filled with 3.2 kg (7.0 lb) of carbon dioxide per room.
- Rooms measuring over 100 m<sup>2</sup> (1080 ft<sup>2</sup>)  
One additional fire extinguisher for each additional 50 m<sup>2</sup> (540 ft<sup>2</sup>).

**b) Fixed fire extinguishing equipment**

Fixed fire extinguishing equipment includes sprinklers and carbon dioxide fire extinguishing equipment.

A sprinkler, normally tripped on detecting heat, is not suitable for extinguishing fires in their early stages, but can be useful as a last resort for putting out fires. A preaction sprinkler is recommended, because a sprinkler that is constantly filled with water is liable to spray water accidentally upon contact. In a computer room furnished with sprinklers, piping is needed to drain any water that is sprayed.

A pushbutton switch should be installed near the computer room access door to allow operators to turn off the server system and air conditioner before the sprinklers are tripped.

Fixed carbon dioxide fire extinguishing equipment is superior in that it does not cause the contamination associated with other fire extinguishing agents, but their use should be accompanied by other safety provisions, such as creating an escape passage and issuing escape alarms, to ensure the safe escape of the occupants of the room.

**(4) Escape facilities**

The fire escape facilities that need to be maintained are listed below. Daily escape drills are important, including practice in handling of the escape equipment.

**a) Escape facilities**

If the computer room is located in the basement or on any floor between the second and the tenth floor of the building, one of the following escape facilities should be selected and maintained:

- Basement  
Escape ladder, escape staircase
- Floors between the second and the tenth floor  
Slide, escape ladder, lift, escape bridge, escape chute

The installation of these facilities is also recommended on floors higher than the tenth or provide an escape to the rooftop, to a lower floor, or to an adjoining building, etc.

**b) Escape passage**

A computer room with devices installed in an intricate layout can be a maze which requires extra time to find a way out of the room or which can cause injuries due to hitting devices in the course of escape. An escape passage at least 1.5 m (4.9 ft) wide should be available to expedite escape. Escape or passage guide lights should be located where they are visible from anywhere in the room.

## (5) Other considerations for fire prevention

Other major considerations for fire prevention are:

- Risks of fires spreading from neighboring buildings
- Fire resistance of the building
- Fire resistance of the computer room and the data storage room
- Fire prevention facilities at openings, such as windows and doors
- Fire dampers (e.g. for ducts)
- Non flammable air conditioner inlets and outlets, and ducting heat insulators
- Treatment of the area where walls are penetrated by wiring cables to prevent fire spreading and smoke leakage
- Emergency power breakers interlocked with the computer room and air conditioners
- Emergency opening and closing of the data storage room door
- Fire prevention control standards, and specific duties for the fire prevention supervisor and the fire manager
- Private fire brigade and fire fighting drills
- Maintenance and inspection of fire-fighting and escape facilities

The points of fire preventive actions for data storage rooms are:

- Provisions should be made for cutting off the supply of lighting power to the data storage room when it is not used to prevent the occurrence of fires caused by power leaks.
- The storage warehouse must be such that the internal temperature will not rise above 60 °C (140 °F) and that it will not allow the entry of any corrosive gases and vapor that may be generated in a fire so as to preserve the data recorded on the stored media.

### 8.2.2 Earthquakes

Earthquakes of any strength can occur at any time over a broad area. Because big earthquakes can cause secondary disasters, earthquake control should provide measures against fire and water damage, as well as against overturning and collapse.

To minimize the effects of earthquakes, the building that houses the server system should be located in a less quake-stricken district. But the most effective earthquake control action is to augment the earthquake-proofing of the building itself.

Common buildings are designed pursuant to the Building Standards Law and other relevant laws. This should keep a building free from critical damage even in a huge earthquake. (When the seismic intensity scale is about 5)

Server systems are designed to withstand a horizontal seismic intensity of  $2.5\text{m/S}^2$  ( $8.2\text{ft/S}^2$ ). Certain devices are furnished with casters to facilitate their relocation. These devices should be secured to the floor, walls, or elsewhere in a manner as appropriate to protect from mechanical destruction. Depending on the type of floor on which the server system is installed, earthquake motion could be amplified to a level several times higher than the ground motion. Hence, earthquake control should be matched to the earthquake motion conditions of the floor on which the server system is erected. For detail of an earthquake preparedness, consult with the construction department of Fujitsu.

### **8.2.3 Water damage**

Water damage to server systems, power supplies, and air conditioners often results from leaks. The performance of the server system could be impaired by the entry of rainwater through the rooftop, outside walls, windows and other locations, water leaking from supply/drainage pipes in the ceiling, or defective facilities that use water on the floors above.

Safeguards generally available against these threats are described below:

#### **(1) Asphalt waterproofing**

Form a waterproof layer through combined bonding of asphalt and roofing to seal any defects in the waterproofing of the rooftop or the floor above. The rooftop requires the most meticulous waterproofing, particularly when a computer room is located on the uppermost floor of the building.

#### **(2) Window structures**

Openings around windows could allow the entry of rainwater or cause damage to glass panes during strong wind or rainfall. It is best if the computer room has no windows. If this is not possible, build the computer room airtight with reinforced glass or double-pane windows if possible, and include a shutter that can be closed during strong wind or rainfall.



### **(3) Water leaking from supply/drainage pipes**

If a new building is to be built, avoid the construction of supply/drainage pipes around the computer room and the data storage room or limit such construction to a minimum. If piping cannot be rerouted in an existing building, install a stop valve at a point just before the pipes enter the room. Avoid installing facilities that use water on the floor right above.

### **(4) Water leaking from air conditioners**

In rooms in which air conditioners are installed, build a dike to stop the outflow of any water which leaks from air conditioners, and provide facilities to drain any water that accumulates. (See [Figure 4.10](#).)

The installation of a water leak detector is recommended to speed up the detection of accidents. When using underfloor ventilation, ensure that the dike does not interfere with the ventilation of conditioned air.

### **(5) Overturning of cleaning buckets**

Do not allow water buckets to be brought into computer rooms. Make sure that mops are cleaned outside the room and squeezed tight to remove water before they are brought into the room.

### **(6) Water used to extinguish fires**

If fire fighting has been conducted anywhere in the building, water used to extinguish the fire could flow into rooms through stairways and passages. Build a dike at the computer room entrance to stop such inflow.

### **(7) Other considerations for water damage prevention**

Other major considerations for water damage prevention are:

- Flooding caused by tidal waves, exceptionally high tides, and other floods
- Water drainage facilities
- Water slopes and drain channels on the floor surfaces
- Air conditioning tank liquid level alarms

## 8.2.4 Burglary

Disasters caused by malicious acts, such as subversive activities, burglary, and obstructive activities, require protection, because these acts are entirely unpredictable.

### (1) Environmental maintenance

To keep unauthorized personnel away from the building or the computer room, ideally, keep the spaces surrounding the building and the computer room clear of obstacles for good visibility, and maintain a monitoring plan and alarms to detect any trespassers immediately. In most situations, however, the detection of unauthorized personnel is made difficult by the fact that buildings are located close to one another with poor visibility and that general-purpose buildings are open to access by many people. Thorough access management is required, including the reinforcement of outside walls on the lower floors, the removal of windows from the lower floors, the elimination of places where unauthorized personnel could hide, and patrols by guards.

### (2) Access management

Have only one regular use door, and have full-time guards verify the identity and belongings of persons entering and leaving the facility. When persons enter the facility, issue badges to them to wear while they are in the facility and ensure that they return the badges when they leave the facility. Visitors should be led to a meeting or reception room for identification by the employee visited. Employees should wear a distinct badge to distinguish themselves from visitors.

### (3) Occupant identification

Access to designated zones, such as the computer room and the data storage room, should be restricted to a pre-registered set of persons. Such access restrictions may be maintained by using occupant identification equipment that works with magnetic cards or similar. Identification equipment should, among other things, control the opening and closing of the door, keep a record of the occupants, and issue alarms to deny access to unauthorized personnel. One drawback is that more than one person may enter or leave the room while the door is open once. To prevent this, double checking the number of people using a photoelectric counter or the like is recommended.

#### **(4) Monitor cameras**

Install monitor cameras in an inconspicuous manner at the entrances to the building, the computer room, etc. for monitoring in the guard room or a monitoring center.

#### **(5) Automatic burglar alarms**

Install automatic burglar alarms at emergency exits or equipment delivery doors that are not in daily use. These should alert the guard room or a monitoring center when trespassing is attempted.

#### **(6) Other considerations for burglary prevention**

Other major considerations for burglary prevention are:

- Creating a burglary prevention organization, and the duties of the burglary prevention supervisor and manager
- Channel of burglary prevention communication
- Access management hours
- Methods of storing, managing, and delivering data
- Management and inspection of storage media and documents

### **8.2.5 Rat damage**

If rats penetrate a computer room, they can bite signal or power cables or urinate on them, causing problems, such as disconnections, power or water leaks, and defective insulation. To prevent rat damage, cover gaps or holes through which rats could enter, and coat cables and cable ducts with rat repellent. Also, do not allow food or drinks to be brought into the computer room.

Some of the commercially available repellents are flammable until they dry or are based on organic solvents. Be careful when handling these repellents.

## **8.3 Maintenance and Management of Disaster Control Facilities**

Long-term maintenance and management of disaster control facilities are essential to putting them to use in emergencies. Poorly maintained and managed disaster control facilities have been ineffective in numerous instances in the past, leading to large scale disasters. As mentioned in the text, supervisors and managers should be appointed to ensure periodic maintenance and inspections.

# Appendix A Conversion Information

- [Units of Measure Conversion](#)
- [Fraction to Decimal Equivalence](#)

## A.1 Units of Measure Conversion

To use the table below, find the original unit in the first column, the new unit in the second column, then multiply the original value by the number in the third column.

Table A.1 Units-of-measure conversion

To Convert	Into	Multiply By
Btu/hr	kcal/hr	0.252
tons	Btu/hr	12,000
kW	Btu/hr	3412.1
Btu/hr	hp	$3.929 \times 10^{-4}$
kVA (3-phases)	Amps per phase	$1000/(1.732 \times \text{Volts})$ (Note 1)
kVA (1-phase)	Amps per phase	$1000/\text{Volts}$ (Note 2)
° C	° F	$(\text{° C} \times 1.8) + 32$
° F	° C	$(\text{° F} - 32)/1.8$
$\text{m}^3/\text{min}$	$\text{ft}^3/\text{min}$	35.3144
$\text{m}^2$	$\text{ft}^2$	10.7639
m	ft	3.2808
kg	lb	2.20
cm	in	0.3937
in	cm	2.54
$\text{kg}/\text{m}^2$	$\text{lb}/\text{ft}^2$	0.2048

Note1: Volts is the phase-to-phase (line-to-line) voltage.

Note2: Volts is the line-to-neutral voltage.

## A.2 Fraction to Decimal Equivalence

The table below provides a quick reference of fractional decimal equivalent conversions.

Table A.2 Fractions to decimal-equivalent conversion

Fraction	Decimal Equivalent
1/16	0.06
1/8	0.12
3/16	0.19
1/4	0.25
5/16	0.31
3/8	0.38
7/16	0.44
1/2	0.50
9/16	0.56
5/8	0.62
11/16	0.69
3/4	0.75
13/16	0.81
7/8	0.88
15/16	0.94

# Acronyms & Abbreviations

## **A**

AUI Attachment Unit Interface  
AVR Automatic Voltage Regulator

## **C**

CPU Central Processing Unit

## **F**

FDDI Fibre Distributed Data Interface  
FSL Flexible System Link

## **I**

IEC International Electrotechnical  
Commission

## **L**

LAN Local Area Network

## **P**

PCI Peripheral Component Interconnect

## **R**

RCI Remote Cabinet Interface

## **S**

SCCI System Component Control Interface  
SCSI Small Computer System Interface  
SGP Surge Protector

## **U**

UPS Uninterruptible Power Supply

## **W**

WAN Wide Area Network





# Index

## A

AC line for surge attack	92
access	
management	104
route	14
acoustic noise	28
air circulation	29
air condition	38
air conditioner	29, 34
filter	53
air conditioning	
capacity	50
condition	38
facility	13
piping	29
unit	29
airborne dust	43
asphalt waterproofing	102
automatic burglar alarm	105
automatic fire alarm	98
auxiliary support	19

## B

base floor cleaning	22
base floor strength	17
computer room	9
beam strength	9
buffer zone	11
building	8
location	7
structure	9
burglary	104

## C

calculating	
power required	66
rush current	66
ceiling height	17
characteristic of computer room air	
conditioning	33
column strength	9
combined use of direct or duct blowing and	
underfloor ventilation	37

commutating load	73
computer room	
installation	2
installation planning	3
location	12
structure	16
conditions for using	
mobile phone	62
consideration	
for burglary prevention	105
for fire prevention	101
for water damage prevention	103
conversion information	107
converting	
frequency	67
voltage	67
corrosive gas	43

## D

device support planning	3
dike	56
direct blowing	35
disasters caused by human neglect	11
discharge	74
distribution Line	87
distribution line	
insulation testing	89
distribution panel	31, 83
breaker	83
free-standing	84
grounding terminal	79
wall-mounted	84
drainage	10
duct blowing	35
dust	24, 43
dusting	30
dustproof finishing	17

## E

earthquake	101
earthquake-proof	10
electric field	62
electrostatic control in the computer room	63

- 
- equipment  
  template . . . . . 25  
escape facility . . . . . 100  
escape passage . . . . . 100
- F**
- facility control panel . . . . . 31  
fire . . . . . 11, 97  
fire extinguisher . . . . . 99  
fire extinguishing equipment . . . . . 99  
fire-extinguishing facility . . . . . 14  
fireproofing . . . . . 11  
fixed fire extinguishing equipment . . . . . 100  
fixture . . . . . 28  
floor panel  
  for building air conditioner . . . . . 20  
  with airflow control damper . . . . . 20  
floor panel opening . . . . . 19  
floor strength . . . . . 9  
free-access floor . . . . . 18  
  cleaning . . . . . 22  
  construction . . . . . 17  
  panel . . . . . 19  
freedom from power failure . . . . . 68  
furniture . . . . . 28
- G**
- grounding . . . . . 76  
  electrode . . . . . 79  
  equipment in the computer room . . . . . 77  
  facility . . . . . 31  
  LAN device . . . . . 80  
  other equipment . . . . . 76  
  trunk cable . . . . . 79  
grounding connection within distribution  
panel . . . . . 87  
grounding-plate method . . . . . 81
- H**
- handling of vent . . . . . 28  
hardware constraint . . . . . 26  
heat  
  distribution . . . . . 29  
  insulation . . . . . 22  
high-frequency noise . . . . . 74  
high-voltage transformer . . . . . 30
- humidifier . . . . . 52
- I**
- induced noise control . . . . . 87  
input power requirement . . . . . 65  
Installing detector . . . . . 56  
interior . . . . . 22
- K**
- keeping computer system free from power  
failure . . . . . 67  
kind  
  of disaster . . . . . 97  
  of fire extinguishing agent . . . . . 99
- L**
- leakage current . . . . . 75  
level of security . . . . . 95  
lighting . . . . . 23  
line facility . . . . . 32  
load  
  rating . . . . . 75  
  variation . . . . . 73  
long-duration power failure-free system . . . 69
- M**
- magnetic field . . . . . 59  
  control . . . . . 61  
maintainability . . . . . 27  
maintenance outlet . . . . . 24  
monitor camera . . . . . 105
- O**
- object of security . . . . . 96  
occupant identification . . . . . 104  
office installation . . . . . 1  
opening for computer-use . . . . . 19  
output terminal board . . . . . 85
- P**
- permissible temperature and humidity range  
for computer . . . . . 38  
portable fire extinguisher . . . . . 99  
power control box . . . . . 92  
power failure-free system . . . . . 69  
power supply facility . . . . . 13, 30, 67

- for air conditioner . . . . . 31
- for computer equipment . . . . . 30
- preventing
  - dew condensation in underfloor ventilation . . . . . 55
  - freezing of cooling water . . . . . 57
  - water leak and installing detector . . . . . 56
- prevention of entry of outside air . . . . . 23
- protection
  - against lightning . . . . . 91
  - of AC line . . . . . 92
  - of signal line . . . . . 94
- R**
- raised floor height . . . . . 18
- rat damage . . . . . 105
- recommended electrostatic voltage for computer room . . . . . 63
- recommended temperature and humidity for computer room . . . . . 39
- reducing harmonic current . . . . . 67
- reducing leakage current . . . . . 67
- removing dust . . . . . 43
- rush current . . . . . 73
- S**
- scale . . . . . 25
- scheduling . . . . . 5
- seawater (salt damage) . . . . . 44
- security action . . . . . 95
- separate transformer . . . . . 31
- shaping waveform . . . . . 67
- share of responsibility for construction in a computer room . . . . . 88
- shielding from direct sunlight . . . . . 23
- signal ground . . . . . 80
- signal wiring facilities . . . . . 32
- slit floor panel . . . . . 19
- sound absorption and insulation . . . . . 23
- sources of magnetic field and fault symptom . . . . . 60
- space . . . . . 12
- static electricity . . . . . 63
- step-down transformer . . . . . 31
- strength of free-access floor panel . . . . . 19
- styles of air conditioner . . . . . 34
- support staff assignment . . . . . 3
- surface material of free-access floor panel . 19
- surge . . . . . 91
- T**
- telecommunication equipment . . . . . 14
- temperature/humidity sensor . . . . . 54
- thermal load imposed on air conditioner . . 45
- top view . . . . . 25
- transformer
  - dedicated to 200 V computer system . . . 70
  - dedicated to 400 V computer system . . . 71
- typical distribution panel setup . . . . . 84
- U**
- underfloor ventilation . . . . . 36, 37, 49
- UPS
  - load specification . . . . . 73
  - requirement . . . . . 72
  - terminating requirement . . . . . 74
- V**
- vibration . . . . . 10
- voltage conversion . . . . . 67
- voltage regulator . . . . . 30
- W**
- water
  - damage . . . . . 10, 102
  - stock . . . . . 16
- water leaking
  - from air conditioner . . . . . 103
  - from supply/drainage pipe . . . . . 103
- window structure . . . . . 102
- wiring
  - route . . . . . 26
  - volume . . . . . 26



# Reader's Comment Form

We would appreciate your comments and suggestions for improving this publication.

Date: \_\_\_\_\_  
 Your Name: \_\_\_\_\_  
 Company: \_\_\_\_\_  
 Address: \_\_\_\_\_  
 City/State/Zip: \_\_\_\_\_  
 Phone/Email address: \_\_\_\_\_

Publication No.: C120-H007-05EN  
 Publication Name: SPARC Enterprise/  
 PRIMEQUEST Common  
 Installation Planning Manual

Your Comments:

Page	Line	Comments
Reply requested: <input type="checkbox"/> Yes <input type="checkbox"/> No		

Please evaluate the overall quality of this manual by checking (✓) the appropriate boxes .

	Good Fair Poor		Good Fair Poor		Good Fair Poor
Organization:	<input type="checkbox"/> <input type="checkbox"/> <input type="checkbox"/>	Use of examples:	<input type="checkbox"/> <input type="checkbox"/> <input type="checkbox"/>	Legibility:	<input type="checkbox"/> <input type="checkbox"/> <input type="checkbox"/>
Accuracy:	<input type="checkbox"/> <input type="checkbox"/> <input type="checkbox"/>	Index coverage:	<input type="checkbox"/> <input type="checkbox"/> <input type="checkbox"/>	Binding:	<input type="checkbox"/> <input type="checkbox"/> <input type="checkbox"/>
Clarity:	<input type="checkbox"/> <input type="checkbox"/> <input type="checkbox"/>	Cross		Figures and tables:	<input type="checkbox"/> <input type="checkbox"/> <input type="checkbox"/>
Overall rating of		referencing:	<input type="checkbox"/> <input type="checkbox"/> <input type="checkbox"/>	General appearance:	<input type="checkbox"/> <input type="checkbox"/> <input type="checkbox"/>
this publication:	<input type="checkbox"/> <input type="checkbox"/> <input type="checkbox"/>				
Technical level:	<input type="checkbox"/> Too detailed	<input type="checkbox"/> Appropriate	<input type="checkbox"/> Not enough detail		

All comments and suggestions become the property of Fujitsu Limited.

**For Users in U.S.A., Canada, and Mexico**

Fold and fasten as shown on back  
 No postage necessary if mailed in U.S.A.

Fujitsu America, Inc  
 Attention: Engineering Support M/S 249  
 1250 East Arques Ave  
 Sunnyvale, CA. 94085-5401  
 USA  
 FAX: (408) 992-2674

**For Users in Other Countries**

Fax this form to the number below or send this form to the address below.

Fujitsu Learning Media Limited  
 FAX: 81-3-6710-1578  
 13-34 Kounan 2-chome  
 Minato-Ku  
 Tokyo 108-0075  
 JAPAN

FOLD AND TAPE

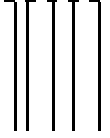

NO POSTAGE  
NECESSARY  
IF MAILED  
IN THE  
UNITED STATES

# BUSINESS REPLY MAIL

FIRST-CLASS MAIL PERMIT NO 741 SUNNYVALE CA

POSTAGE WILL BE PAID BY ADDRESSEE

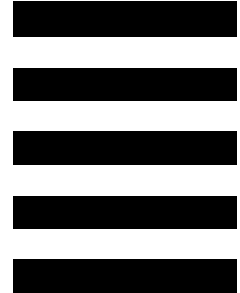

FUJITSU AMERICA, INC  
ATTENTION ENGINEERING SUPPORT M/S 249  
1250 EAST ARQUES AVENUE  
SUNNYVALE CA 94085-5401



FOLD AND TAPE



**FUJITSU**