

PARTS LIST

Vacuum Cleaner

SC-27Y (U.S.A.)

Specifications



Power source	: AC 120 V 60 Hz
Power consumption	: 6.5A
Motor revolution	: 29,500 r.p.m.
Vacuum	: 1,950 mmAq
Dimensions LXWXH	: 13 - 19/32" x 9 - 17/32" x 10 - 1/4" (345 x 242 x 260 mm)
Net weight	: 6 lbs. 6 ozs. (2.9 Kg)
Attachment	: Suction hose, Floor tool, Rotary bend, Connection pipe, Crevice tool, Upholstery brush

PRODUCT CODE NO.
1 - 326 657 02 (Y)

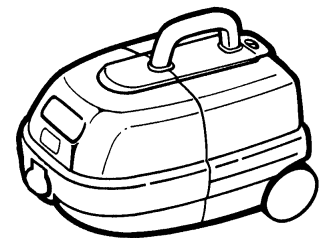
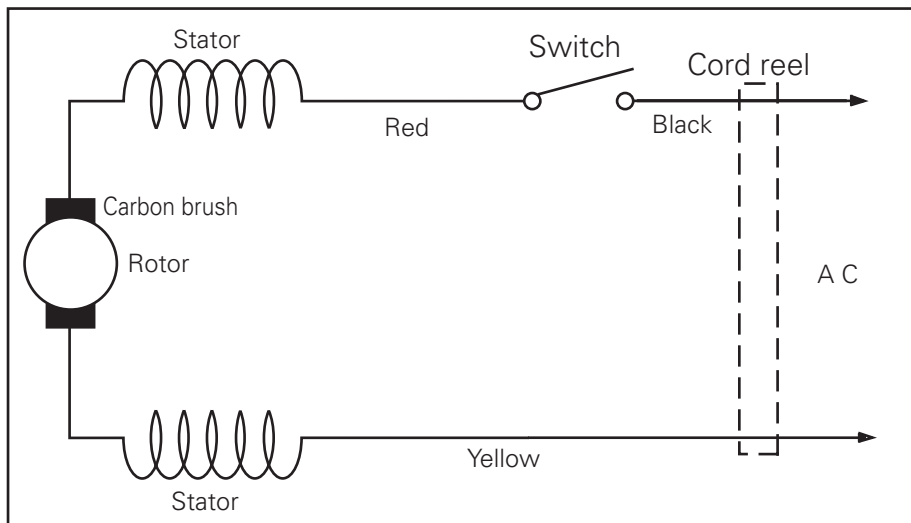
Wiring Diagram





Exploded View (Main unit)

NOTE: The parts marked with  have special characteristics of safety, if replace the  mark parts, use only SANYO specified parts.

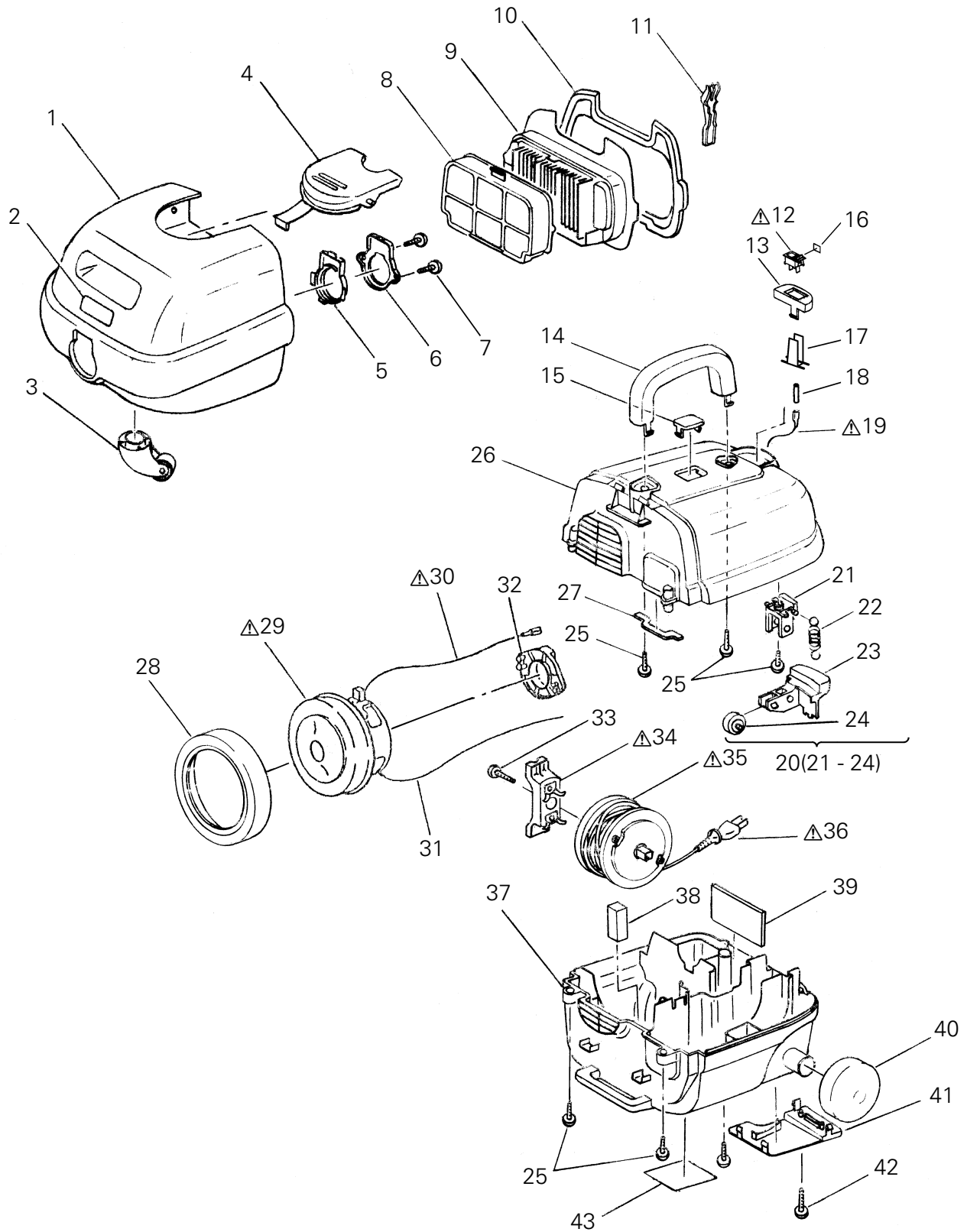







SC-27Y (U.S.A.)



**Parts List
(Main unit)**

NOTE: The parts marked with  have special characteristics of safety,
if replace the  mark parts,use only SANYO specified parts.

SC-27Y (U.S.A.)

Key No.	Parts No.	Description	Q'ty	Key No.	Parts No.	Description	Q'ty
1	616 140 6637	DUST BOX (Y-108)	1				
2	616 131 1856	DUST BOX INSCRIPTION (NN-B)	1				
3	616 000 1314	CASTER (NN-B)	1				
4	616 140 6644	CRAMP HOOK (Y-101)	1				
5	616 004 5219	AIR INLET PACKING (NN-B)	1				
6	616 004 5486	AIR INLET FITTING	1				
7	411 006 8103	SCR TPG PAN 4X16	2				
8	616 103 8982	PRE FILTER	1				
9	616 103 8999	DUST FILTER ASSEMBLY	1				
10	616 103 9002	DUST FILTER PACKING (NN-05)	1				
11	616 115 3081	DUSTER ARM (NN-B)	1				
	12 616 129 2391	SWITCH	1				
13	616 140 6552	SWITCH ORNAMENT (Y-101)	1				
14	616 115 3043	HANDLE (NN-B)	1				
15	616 140 6569	CASE ORNAMENT (Y-101)	1				
16	616 011 9422	CAUTION LABEL	1				
17	616 140 6521	SWITCH HOLDER	1				
18	616 129 2520	VINYL TUBE (L=20)	1				
	19 616 129 2537	CORD ASSEMBLY (BLACK) L=280	1				
20	616 140 6576	BRAKE ROLLER ASSEMBLY A KEYNO.21-24	1				
21	616 008 7554	BRAKE ARM BRACKET (BR-20)	1				
22	616 008 7455	BRAKE SPRING	1				
23	616 140 6583	BRAKE ARM (Y-101)	1				
24	616 002 1398	BRAKE ROLLER ASSEMBLY B	1				
25	411 006 8301	SCR TPG PAN 4X20	6				
26	616 140 6590	CASE UPPPER (Y-101)	1				
27	616 103 8739	POLYURETHANE FORM A	1				
28	616 103 0375	MOTOR CUSHION FRONT (NN-B)	1				
	29 616 107 1910	MOTOR COMP. (AC 120V)	1				
	616 100 0262	CARBON BRUSH ASSEMBLY	2				
	30 616 129 2544	CORD ASSEMBLY (BLACK) L=350	1				
31	616 103 3840	LEAD WIRE (YELLOW) L=300	1				
32	616 100 7094	MOTOR CUSHION REAR	1				
33	411 007 0700	SCR TPG TRS 4X16	1				
	34 616 002 0834	REEL SUPPORTER ASSEMBLY	1				
	35 616 116 6968	CORD REEL COMP. INCL/P.CORD	1				
	36 616 140 6514	POWER CORD (U2)	1				
37	616 140 6606	CASE LOWER (Y-101)	1				
38	616 103 8821	INDICATOR FILTER	1				
39	616 109 6234	OUTLET FILTER	1				
40	616 103 8845	WHEEL REAR (NN-B)	2				
41	616 140 6613	CORD INLET COVER (Y-101)	1				
42	411 067 5202	SCR TPG PAN 3X20	1				
43	616 140 6620	NAME PLATE	1				

COLOR CODE:Y-101/Y-108(YELLOW),BR-20(BROWN),NN-05(GRAY),NN-B(BLACK)

**Exploded View
(Attachment)**

SC-27Y (U.S.A.)

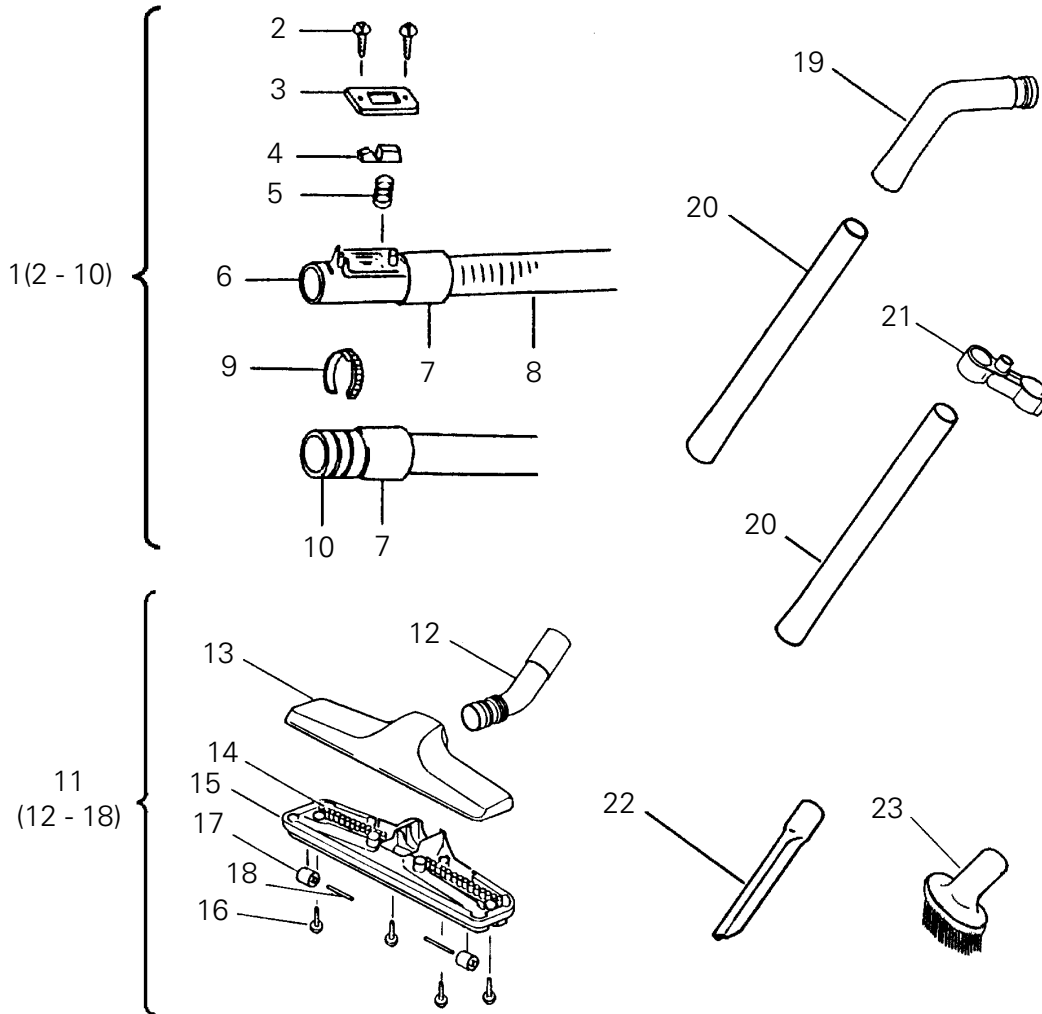

Parts List

Key No.	Parts No.	Description	Q'ty	Key No.	Parts No.	Description	Q'ty
1	616 127 6827	SUCTION HOSE COMP. KEYNO.2-10	1	16	411 006 8103	SCR TPG PAN 4X16	4
2	411 067 8708	SCR TPG PAN 3X8M	2	17	616 129 2506	WHEEL SMALL (NN-B)	2
3	616 115 3104	HOSE HOOK COVER (NN-B)	1	18	616 104 8936	SHAFT FRONT	2
4	616 018 1184	HOSE HOOK (NN-B)	1	19	616 126 9911	ROTARY BEND (NN-B)	1
5	616 018 1283	HOSE HOOK SPRING	1	20	616 115 3159	CONNECTION PIPE (NN-B)	2
6	616 115 3111	HOSE JOINT PIPE A (NN-B)	1	21	616 115 3166	PIPE RETAINER ASSEMBLY	1
7	616 103 9040	SUCTION HOSE COVER (NN-B)	2	22	616 115 8147	CREVICE TOOL (NN-B)	1
8	616 123 4353	SUCTION HOSE (NN-B)	1	23	616 017 3592	UPHOLSTERY BRUSH ASSEMBLY (NN-B)	1
9	616 115 3128	ROTARY BEND SET RING (NN-B)	1				
10	616 115 3135	HOSE GRIP PIPE (NN-B)	1				
11	616 129 2452	FLOOR TOOL COMP. KEYNO.12-18	1				
12	616 129 2469	BEND (NN-B)	1				
13	616 129 2476	FLOOR TOOL CASE(NN-B)	1				
14	616 129 2483	FLOOR TOOL BASE ASSEMBLY	1				
15	616 129 2490	FLOOR TOOL BUMPER(NN-B)	1				

COLOR CODE:NN-B(BLACK)

For Parts or Service Contact
SANYO FISHER SERVICE CORPORATION.
 1411 West 190th Street Suite 700
 South Bay Corporate Center Gardena, CA 90248