

**EPSON**

# **SED1520 Series**

LCD driver with RAM

Technical Manual

SEIKO EPSON CORPORATION



## NOTICE

---

No parts of this material may be reproduced or duplicated in any form or by any means without the written permission of Seiko Epson. Seiko Epson reserves the right to make changes to this material without notice. Seiko Epson does not assume any liability of any kind arising out of any inaccuracies contained in this material or due to its application or use in any product or circuit and, further, there is no representation that this material is applicable to products requiring high level reliability, such as, medical products. Moreover, no license to any intellectual property rights is granted by implication or otherwise, and there is no representation or warranty that anything made in accordance with this material will be free from any patent or copyright infringement of a third party. This material or portions thereof may contain technology or the subject relating to strategic products under the control of the Foreign Exchange and Foreign Trade Control Law of Japan and may require an export licence from the Ministry of International Trade and Industry or other approval from another government agency.

© Seiko Epson corporation 1998 All right reserved.

i8088 and i8086 are registered trademarks of Intel Corporation.

Z80 is registered trademark of Zilog Corporation.

V20 and V30 are registered trademarks of Nippon Electric Corporation.

# **CONTENTS**

## Selection Guide

1. SED1510 Series
2. SED1520 Series
3. SED152A Series
4. SED1526 Series
5. SED1530 Series
6. SED1540 Series
7. SED1560 Series
8. SED1565 Series
9. SED1570 Series

# **SED1500 Series Selection Guide**

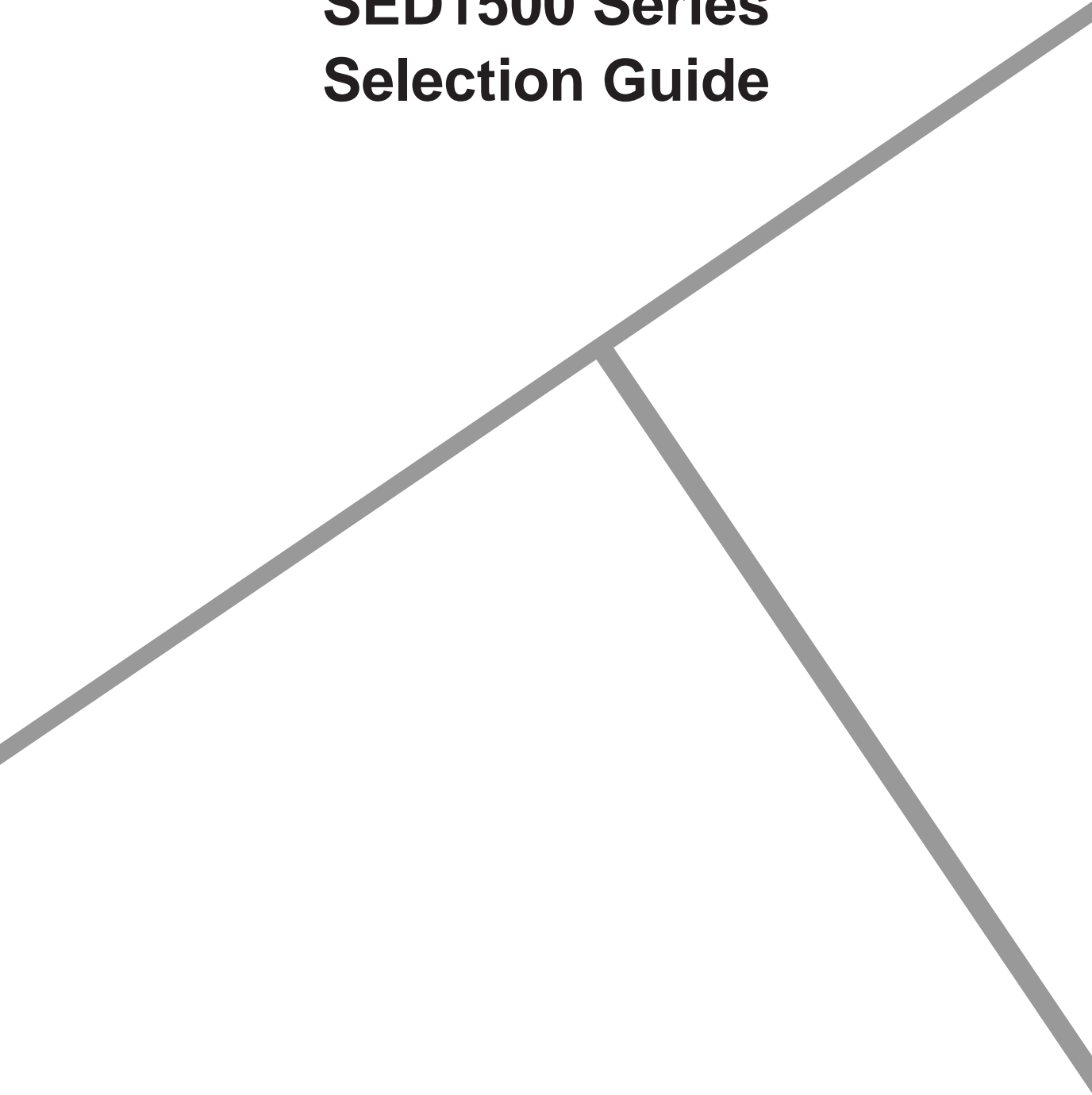

■ **LCD drivers with RAM for small- and medium-sized displays**

Ultra-low power consumption and on-chip RAM make this series ideal for compact LCD-based equipment.

SED1500 series

Part number	Supply voltage range (V)	LCD voltage range (V)	Duty	Segment	Common	Display RAM (bits)	Microprocessor interface	Frequency (KHz)	Package	Application/additional features				
SED1510D0C	0.9–6.0	1.8–6.0	1/4	32	4	128	Serial	18 (internal)	Al pad chip	Small segment-type LCD display. Command and data interface				
SED1510D0B									Au bump chip					
SED1510F0C									QFP12-48pin					
SED1510F0E									QFP6-60pin					
SED1511D0A														
SED1520D0A	2.4–7.0	3.5–13	1/16, 1/32	61	16	2,560	8-bit parallel	18 (internal, external)	Al pad chip	Dot-matrix LCD displays Extension driver is the SED1521.				
SED1520D0B									Au bump chip					
SED1520F0A									QFP5-100pin					
SED1520F0C									QFP15-100pin					
SED1520T0A									TCP					
SED1520DAA									Al pad chip					
SED1520DAB			Au bump chip											
SED1520FAA			QFP5-100pin											
SED1520FAC			QFP15-100pin											
SED1520TAA#			TCP											
SED1521D0A			1/8–1/32	80	–			–	–		18 (external)	Al pad chip	Extension driver for the SED1520 and SED1522	
SED1521D0B												Au bump chip		
SED1521F0A		QFP5-100pin												
SED1521F0C		QFP15-100pin												
SED1521T0A#		TCP												
SED1521DAA		Al pad chip												
SED1521DAB		Au bump chip												
SED1521FAA		QFP5-100pin												
SED1521FAC		QFP15-100pin												
SED1521TAA#		TCP												
SED152AD0A		Al pad chip								P-substrate version of SED1521				
SED1522D0A		1/8, 1/16								69	8	8		8
SED1522D0B			Au bump chip											
SED1522F0A			QFP5-100pin											
SED1522F0C	QFP15-100pin													
SED1522T0A#	TCP													
SED1522DAA	Al pad chip													
SED1522DAB	Au bump chip													
SED1522FAA	QFP5-100pin													
SED1522FAC	QFP15-100pin													
SED1522TAA#	TCP													
SED1540D0A	3.5–11		1/3, 1/4	73	3, 4	3, 4	18 (internal) 4 (external)	Al pad chip	Segment-type displays					
SED1540D0B								Au bump chip						
SED1540F0A		QFP5-100pin												

Part number	Supply voltage range (V)	LCD voltage range (V)	Duty	Segment	Common	Display RAM (bits)	Microprocessor interface	Frequency (KHz)	Package	Application/additional features
SED1560D0A	2.4–6.0	6.0–16.0	1/48, 1/49 1/64, 1/65	102	65	166×65 bits	8-bit parallel or Serial	18	Al pad chip	Built-in power circuit for LCD (voltage tripler) SED1560*0B (1/9 bias) SED1560*AB (1/7 bias) SED1561*0B (1/7 bias) SED1561*AB (1/5 bias)
SED1560DAA									Al pad chip	
SED1560D0B									Au bump chip	
SED1560DAB									Au bump chip	
SED1560T0B									TCP	
SED1560TQA									QTCP	
SED1561D0A			Al pad chip							
SED1561DAA			Al pad chip							
SED1561D0B			Au bump chip							
SED1561DAB			Au bump chip							
SED1561T0B			TCP							
SED1561TAB			TCP							
SED1561TQA			QTCP							
SED1562D0A			Al pad chip							
SED1562D0B			Au bump chip							
SED1562T0B	TCP									
SED1562TQA	QTCP									
SED1565D0B	1.8–5.5	4.5–16.0	1/65 (1/7, 1/9 bias)	132	65	132×65 bits	33	33	Au bump chip	Built-in power circuit for LCD (DC/DC×4)
SED1565D1B*									Au bump chip	
SED1565D2B									Au bump chip	
SED1565T0A					TCP					
SED1565T0B					TCP					
SED1565T0C					TCP					
SED1566D0B			Au bump chip							
SED1566D1B*			Au bump chip							
SED1566D2B			Au bump chip							
SED1566T0A			TCP							
SED1567D0B			Au bump chip							
SED1567D1B*			Au bump chip							
SED1567D2B			Au bump chip							
SED1567T0B			TCP							
SED1567T0C			TCP							
SED1568D0B	Au bump chip									
SED1569D0B	Au bump chip									
SED1569T**	TCP									
SED1570D0A	2.7–5.5	8.0–20.0	1/64–1/200	80	–	200×80 bits	4-bit parallel	–	Al pad chip	Built-in self-refreshing function
SED1570D0B									Au bump chip	
SED1526D*A	2.4–6.0	3.5– Supply voltage <sup>×3</sup>	1/8, 1/9 1/16, 1/17	80	17	80×33 bits	8-bit parallel or Serial	20	Al pad chip	Built-in power circuit for LCD (voltage tripler) SED1526*0* (VREG) SED1526*E* (no VREG) SED1526*A* (redistribution of COMS) SED1528*0* (VREG) SED1528*E* (no VREG)
SED1526D*B									Au bump chip	
SED1526F*A									QFP5-128pin	
SED1526T*A									TCP	
SED1528D*A			Al pad chip							
SED1528D*B			Au bump chip							
SED1528F*A			QFP5-128pin							
SED1528T*A			TCP							

Part number	Supply voltage range (V)	LCD voltage range (V)	Duty	Segment	Common	Display RAM (bits)	Microprocessor interface	Frequency (KHz)	Package	Application/additional features
SED1530D0A	2.4-6.0	4.5-16.0	1/32, 1/33	100	33	132x65 bits	8-bit parallel or Serial	-	Al pad chip	Built-in power circuit for LCD (voltage quadrupler) SED153**0** (Common: Right side) SED153**A** (Common: Both side) SED153**E** (Common: Left side) SED153**F** (no VREG)
SED1530DAA									Al pad chip	
SED1530D0B									Au bump chip	
SED1530DAB									Au bump chip	
SED1530TAA									TCP	
SED1531D0A			Al pad chip							
SED1531D0B			Au bump chip							
SED1531T0A			TCP							
SED1532D0A			Al pad chip							
SED1532DBA			Al pad chip							
SED1532D0B			Au bump chip							
SED1532DBA			Au bump chip							
SED1532T0A			TCP							
SED1532TBA			TCP							
SED1535D0B*			1/35	98	35				Au bump chip	

TCP : Tape Carrier Package

## **2. SED1520 Series**

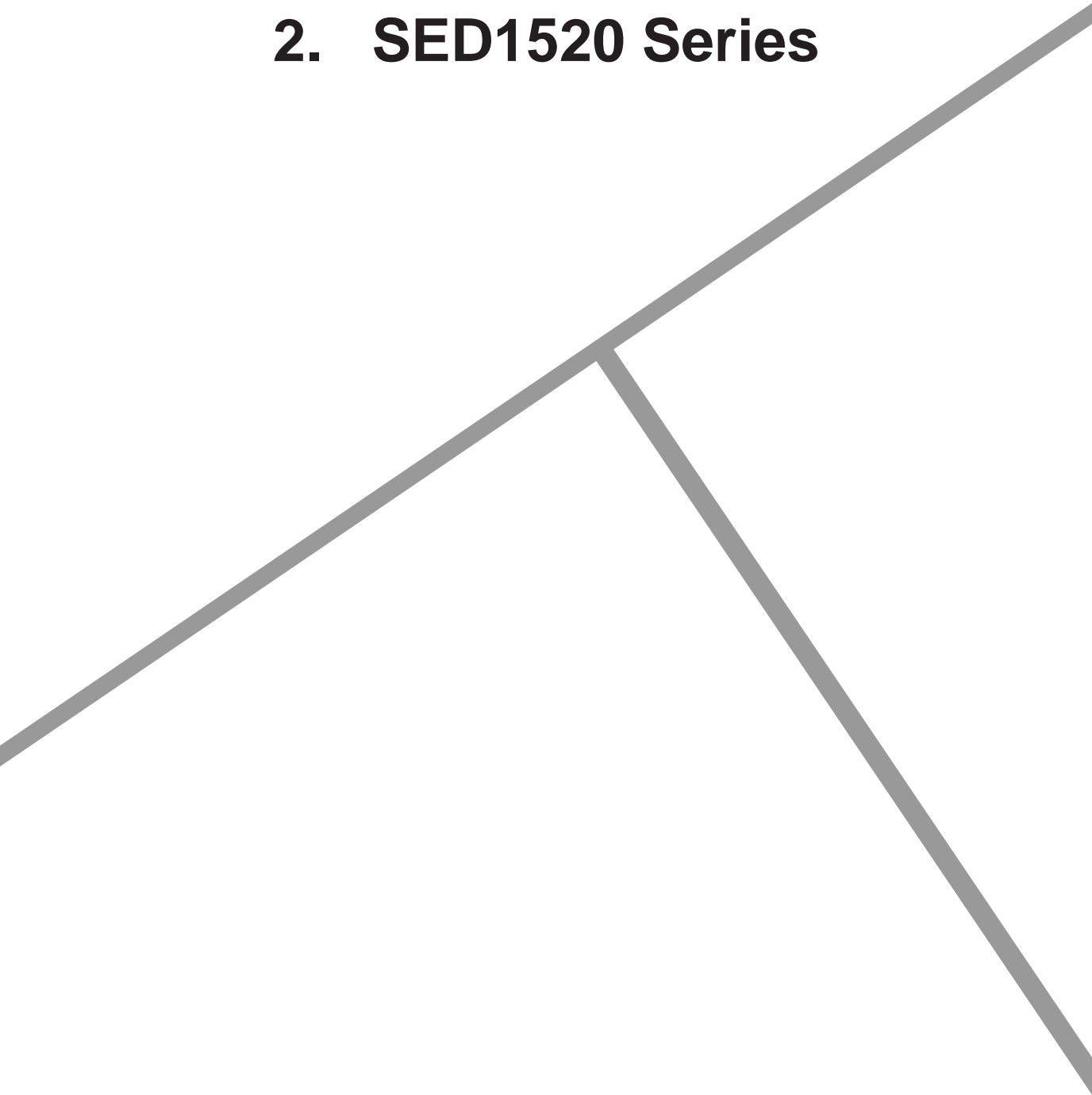



# Contents

OVERVIEW .....	2-1
FEATURES .....	2-1
BLOCK DIAGRAM .....	2-2
PACKAGE OUTLINE .....	2-3
PAD .....	2-4
Pad Arrangement .....	2-4
PAD ARRANGEMENT .....	2-5
PIN DESCRIPTION .....	2-6
(1) Power Pins .....	2-6
(2) System Bus Connection Pins .....	2-6
(3) LCD Drive Circuit Signals .....	2-7
BLOCK DESCRIPTION .....	2-8
System Bus .....	2-8
Display Start Line and Line Count Registers .....	2-9
Column Address Counter .....	2-9
Page Register .....	2-9
Display Data RAM .....	2-9
Common Timing Generator Circuit .....	2-10
Display Data Latch Circuit .....	2-10
LCD Driver Circuit .....	2-10
Display Timing Generator .....	2-10
Oscillator Circuit (SED1520*0A Only) .....	2-11
Reset Circuit .....	2-11
COMMANDS .....	2-14
Summary .....	2-14
Command Description .....	2-15
SPECIFICATIONS .....	2-20
Absolute Maximum Ratings .....	2-20
Electrical Specifications .....	2-20
APPLICATION NOTES .....	2-26
MPU Interface Configuration .....	2-26
LCD Drive Interface Configuration .....	2-27
LCD Panel Wiring Example .....	2-29
Package Dimensions .....	2-30



**BLOCK DIAGRAM**

An example of SED1520\*AA:

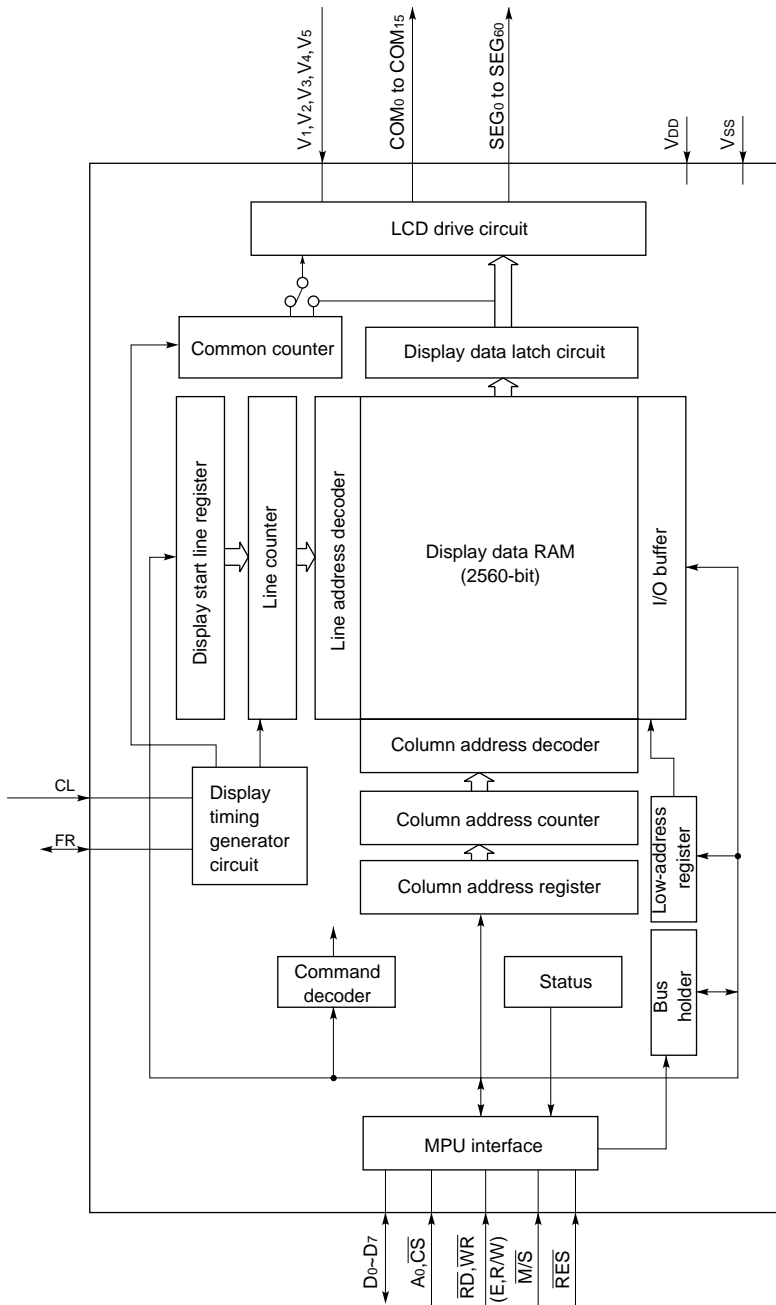

PACKAGE OUTLINE

QFP5

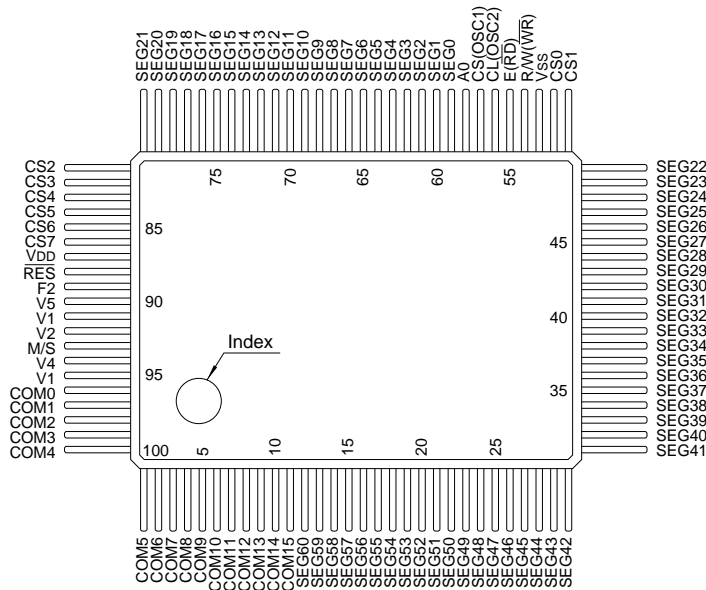

SED1520 Series

QFP15

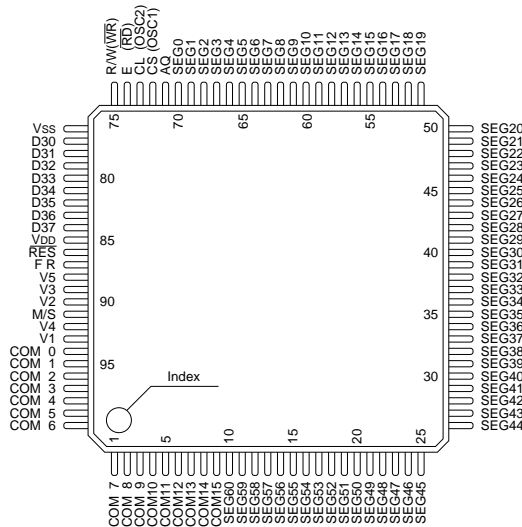

Note: This is an example of SED1520F pin assignment. The modified pin names are given below.

Product Name	Pin/Pad Number					
	74	75	96 to 100, 1 to 11	93	94	95
SED1520F0A	OSC1	OSC2	COM0 to COM15*	M/S	V4	V1
SED1521F0A	CS	CL	SEG76 to SEG61	SEG79	SEG78	SEG77
SED1522F0A	OSC1	OSC2	COM0 to 7, SEG68 to 61	M/S	V4	V1
SED1520FAA	CS	CL	COM0 to COM15*	M/S	V4	V1
SED1521FAA	CS	CL	SEG76 to SEG61	SEG79	SEG78	SEG77
SED1522FAA	CS	CL	COM0 to 7, SEG68 to 61	M/S	V4	V1

SED1520: Common outputs COM0 to COM15 of the master LSI correspond to COM31 to COM16 of the slave LSI.

SED1522: Common outputs COM0 to COM15 of the master LSI correspond to COM15 to COM8 of the slave LSI.

**PAD**

**Pad Arrangement**

**Chip specifications of AL pad package**

Chip size: 4.80×7.04×0.400 mm

Pad pitch: 100×100 μm

**Chip specifications of gold bump package**

Chip size: 4.80×7.04×0.525 mm

Bump pitch: 199 μm (Min.)

Bump height: 22.5 μm (Typ.)

Bump size: 132×111 μm (±20 μm) for mushroom model  
116×92 μm (±4 μm) for vertical model

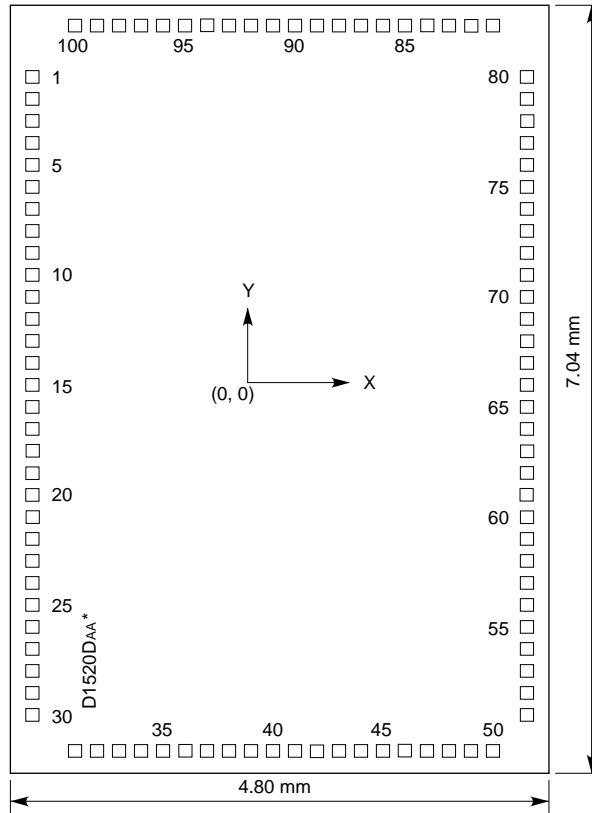

Note: An example of SED1520DAA die numbers is given. These numbers are the same as the bump package.

## PAD ARRANGEMENT

An example of SED1520DA\* pin names is given. The asterisk (\*) can be A for AL pad package or B for gold bump package.

### SED1520DAB Pad Center Coordinates

Pad No.	Pin Name	X	Y	Pad No.	Pin Name	X	Y	Pad No.	Pin Name	X	Y
1	COM5	159	6507	35	SEG37	1302	159	69	SEG3	4641	4148
2	COM6	159	6308	36	SEG36	1502	159	70	SEG2	4641	4347
3	COM7	159	6108	37	SEG35	1701	159	71	SEG1	4641	4547
4	COM8	159	5909	38	SEG34	1901	159	72	SEG0	4641	4789
5	COM9	159	5709	39	SEG33	2100	159	73	A0	4641	5048
6	COM10	159	5510	40	SEG32	2300	159	74	CS	4641	5247
7	COM11	159	5310	41	SEG31	2499	159	75	CL	4641	5447
8	COM12	159	5111	42	SEG30	2699	159	76	E (RD)	4641	5646
9	COM13	159	4911	43	SEG29	2898	159	77	R/W (WR)	4641	5846
10	COM14	159	4712	44	SEG28	3098	159	78	Vss	4641	6107
11	COM15	159	4512	45	SEG27	3297	159	79	DB0	4641	6307
12	SEG60	159	4169	46	SEG26	3497	159	80	DB1	4641	6506
13	SEG59	159	3969	47	SEG25	3696	159	81	DB2	4295	6884
14	SEG58	159	3770	48	SEG24	3896	159	82	DB3	4095	6884
15	SEG57	159	3570	49	SEG23	4095	159	83	DB4	3896	6884
16	SEG56	159	3371	50	SEG22	4295	159	84	DB5	3696	6884
17	SEG55	159	3075	51	SEG21	4641	482	85	DB6	3497	6884
18	SEG54	159	2876	52	SEG20	4641	681	86	DB7	3297	6884
19	SEG53	159	2676	53	SEG19	4641	881	87	VDD	3098	6884
20	SEG52	159	2477	54	SEG18	4641	1080	88	RES	2898	6884
21	SEG51	159	2277	55	SEG17	4641	1280	89	FR	2699	6884
22	SEG50	159	2078	56	SEG16	4641	1479	90	V5	2499	6884
23	SEG49	159	1878	57	SEG15	4641	1679	91	V3	2300	6884
24	SEG48	159	1679	58	SEG14	4641	1878	92	V2	2100	6884
25	SEG47	159	1479	59	SEG13	4641	2078	93	M/S	1901	6884
26	SEG46	159	1280	60	SEG12	4641	2277	94	V4	1701	6884
27	SEG45	159	1080	61	SEG11	4641	2477	95	V1	1502	6884
28	SEG44	159	881	62	SEG10	4641	2676	96	COM0	1302	6884
29	SEG43	159	681	63	SEG9	4641	2876	97	COM1	1103	6884
30	SEG42	159	482	64	SEG8	4641	3075	98	COM2	903	6884
31	SEG41	504	159	65	SEG7	4641	3275	99	COM3	704	6884
32	SEG40	704	159	66	SEG6	4641	3474	100	COM4	504	6884
33	SEG39	903	159	67	SEG5	4641	3674				
34	SEG38	1103	159	68	SEG4	4641	3948				

The other SED1520 series packages have the different pin names as shown.



Package/Pad No.	74	75	96 to 100, 1 to 11	93	94	95
SED1520D0*	OSC1	OSC2	COM0 to COM15 *	M/S	V4	V1
SED1522D0*	OSC1	OSC2	COM0 to 7, SEG68 to 61	M/S	V4	V1
SED1522DA*	OSC1	OSC2	COM0 to 7, SEG68 to 61	M/S	V4	V1
SED1521D0*	CS	CL	SEG76 to SEG61	SEG79	SEG78	SEG77
SED1521DA*	CS	CL	SEG76 to SEG61	SEG79	SEG78	SEG77

**PIN DESCRIPTION**

**(1) Power Pins**

Name	Description
V <sub>DD</sub>	Connected to the +5Vdc power. Common to the Vcc MPU power pin.
V <sub>SS</sub>	0 Vdc pin connected to the system ground.
V <sub>1</sub> , V <sub>2</sub> , V <sub>3</sub> , V <sub>4</sub> , V <sub>5</sub>	Multi-level power supplies for LCD driving. The voltage determined for each liquid crystal cell is divided by resistance or it is converted in impedance by the op amp, and supplied. These voltages must satisfy the following: V <sub>DD</sub> ≥ V <sub>1</sub> ≥ V <sub>2</sub> ≥ V <sub>3</sub> ≥ V <sub>4</sub> ≥ V <sub>5</sub>

**(2) System Bus Connection Pins**

D7 to D0	Three-state I/O. The 8-bit bidirectional data buses to be connected to the 8- or 16-bit standard MPU data buses.
A0	Input. Usually connected to the low-order bit of the MPU address bus and used to identify the data or a command. A0=0: D0 to D7 are display control data. A0=1: D0 to D7 are display data.
$\overline{\text{RES}}$	Input. When the $\overline{\text{RES}}$ signal goes  , the 68-series MPU is initialized, and when it goes  , the 80-series MPU is initialized. The system is reset during edge sense of the $\overline{\text{RES}}$ signal. The interface type to the 68-series or 80-series MPU is selected by the level input as follows: High level: 68-series MPU interface Low level: 80-series MPU interface
$\overline{\text{CS}}$	Input. Active low. Effective for an external clock operation model only. An address bus signal is usually decoded by use of chip select signal, and it is entered. If the system has a built-in oscillator, this is used as an input pin to the oscillator amp and an Rf oscillator resistor is connected to it. In such case, the $\overline{\text{RD}}$ , $\overline{\text{WR}}$ and E signals must be ORed with the $\overline{\text{CS}}$ signals and entered.
E ( $\overline{\text{RD}}$ )	<ul style="list-style-type: none"> <li>• <u>If the 68-series MPU is connected:</u> Input. Active high. Used as an enable clock input of the 68-series MPU.</li> <li>• <u>If the 80-series MPU is connected:</u> Input. Active low. The RD signal of the 80-series MPU is entered in this pin. When this signal is kept low, the SED1520 data bus is in the output status.</li> </ul>
R/W ( $\overline{\text{WR}}$ )	<ul style="list-style-type: none"> <li>• <u>If the 68-series MPU is connected:</u> Input. Used as an input pin of read control signals (if R/W is high) or write control signals (if low).</li> <li>• <u>If the 80-series MPU is connected:</u> Input. Active low. The <math>\overline{\text{WR}}</math> signal of the 80-series MPU is entered in this pin. A signal on the data bus is fetched at the rising edge of <math>\overline{\text{WR}}</math> signal.</li> </ul>

**(3) LCD Drive Circuit Signals**

Name	Description																												
CL	<p>Input. Effective for an external clock operation model only. This is a display data latch signal to count up the line counter and common counter at each signal falling and rising edges. If the system has a built-in oscillator, this is used as an output pin of the oscillator amp and an Rf oscillator resistor is connected to it.</p>																												
FR	<p>Input/output. This is an I/P pin of LCD AC signals, and connected to the M terminal of common driver.</p> <p><u>I/O selection</u></p> <ul style="list-style-type: none"> <li>• Common oscillator built-in model: Output if M/S is 1; Input if M/S is 0.</li> <li>• Dedicate segment model: Input</li> </ul>																												
SEGN	<p>Output. The output pin for LCD column (segment) driving. A single level of V<sub>DD</sub>, V<sub>2</sub>, V<sub>3</sub> and V<sub>5</sub> is selected by the combination of display RAM contents and RF signal.</p>																												
COMn	<p>Output. The output pin for LCD common (low) driving. A single level of V<sub>DD</sub>, V<sub>1</sub>, V<sub>4</sub> and V<sub>5</sub> is selected by the combination of common counter output and RF signal. The slave LSI has the reverse common output scan sequence than the master LSI.</p>																												
M/S	<p>Input. The master or slave LSI operation select pin for the SED1520 or SED1522. Connected to V<sub>DD</sub> (to select the master LSI operation mode) or V<sub>SS</sub> (to select the slave LSI operation mode). When this M/S pin is set, the functions of FR, COM0 to COM15, OSC1 (<math>\overline{CS}</math>), and OSC2 (CL) pins are changed.</p> <table border="1"> <thead> <tr> <th></th> <th>M/S</th> <th>FR</th> <th>COM output</th> <th>OSC1</th> <th>OSC2</th> </tr> </thead> <tbody> <tr> <td rowspan="2">SED1520F0A</td> <td>V<sub>DD</sub></td> <td>Output</td> <td>COM0 to COM15</td> <td>Input</td> <td>Output</td> </tr> <tr> <td>V<sub>SS</sub></td> <td>Input</td> <td>COM31 to COM16</td> <td>NC</td> <td>Input</td> </tr> <tr> <td rowspan="2">SED1522F0A</td> <td>V<sub>DD</sub></td> <td>Output</td> <td>COM0 to COM7</td> <td>Input</td> <td>Output</td> </tr> <tr> <td>V<sub>SS</sub></td> <td>Input</td> <td>COM15 to COM8</td> <td>NC</td> <td>Input</td> </tr> </tbody> </table> <p>* The slave driver has the reverse common output scan sequence than the master driver.</p>		M/S	FR	COM output	OSC1	OSC2	SED1520F0A	V <sub>DD</sub>	Output	COM0 to COM15	Input	Output	V <sub>SS</sub>	Input	COM31 to COM16	NC	Input	SED1522F0A	V <sub>DD</sub>	Output	COM0 to COM7	Input	Output	V <sub>SS</sub>	Input	COM15 to COM8	NC	Input
	M/S	FR	COM output	OSC1	OSC2																								
SED1520F0A	V <sub>DD</sub>	Output	COM0 to COM15	Input	Output																								
	V <sub>SS</sub>	Input	COM31 to COM16	NC	Input																								
SED1522F0A	V <sub>DD</sub>	Output	COM0 to COM7	Input	Output																								
	V <sub>SS</sub>	Input	COM15 to COM8	NC	Input																								



**BLOCK DESCRIPTION**

**System Bus**

**MPU interface**

1. Selecting an interface type

The SED1520 series transfers data via 8-bit bidirectional data buses (D0 to D7). As its Reset pin has the MPU interface select function, the 80-series MPU or the 68-series MPU can directly be connected to the MPU bus by the selection of high or low  $\overline{RES}$  signal

level after reset (see Table 1).

When the  $\overline{CS}$  signal is high, the SED1520 series is disconnected from the MPU bus and set to stand by. However, the reset signal is entered regardless of the internal setup status.

Table 1

$\overline{RES}$ signal input level	MPU type	A0	E	R/W	CS	D0 to D7
Active low	68-series	↑	↑	↑	↑	↑
Active high	80-series	↑	$\overline{RD}$	$\overline{WR}$	↑	↑

**Data transfer**

The SED1520 and SED1521 drivers use the A0, E (or  $\overline{RD}$ ) and  $\overline{R/W}$  (or  $\overline{WR}$ ) signals to transfer data between the system MPU and internal registers. The combinations used are given in the table below.

In order to match the timing requirements of the MPU with those of the display data RAM and control registers all data is latched into and out of the driver. This introduces a one cycle delay between a read request for data and the data arriving. For example when the MPU

executes a read cycle to access display RAM the current contents of the latch are placed on the system data bus while the desired contents of the display RAM are moved into the latch.

This means that a dummy read cycle has to be executed at the start of every series of reads. See Figure 1.

No dummy cycle is required at the start of a series of writes as data is transferred automatically from the input latch to its destination.

Common	68 MPU	80 MPU		Function
	$\overline{R/W}$	$\overline{RD}$	$\overline{WR}$	
A0				
1	1	0	1	Read display data
1	0	1	0	Write display data
0	1	0	1	Read status
0	0	1	0	Write to internal register (command)

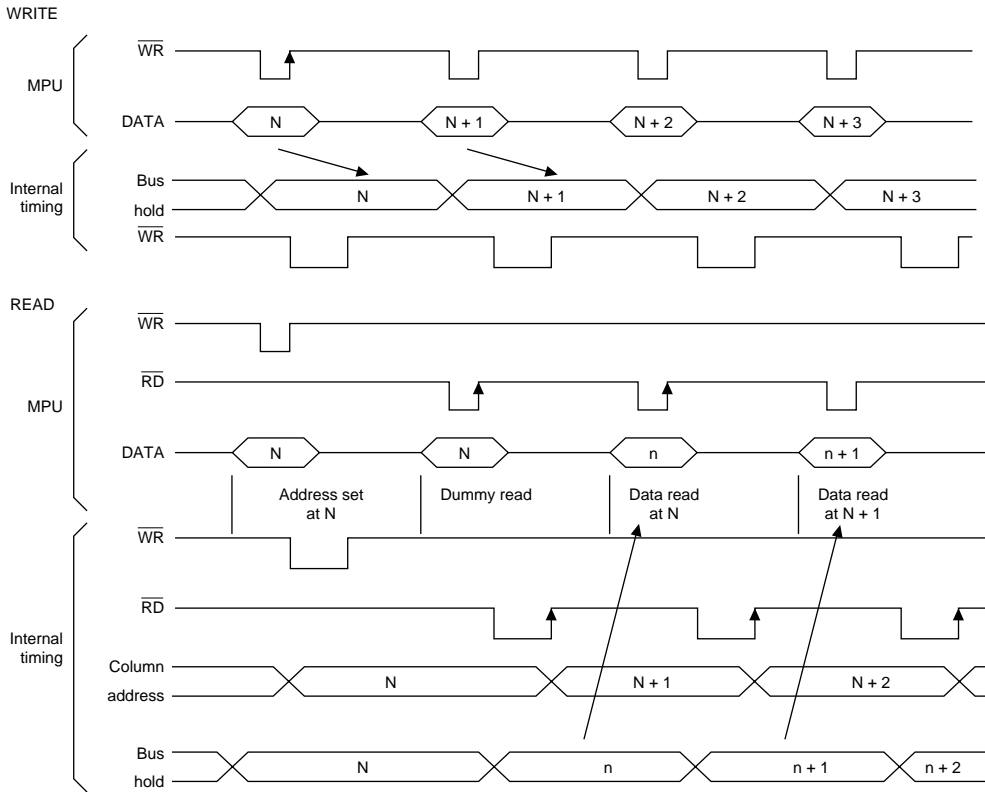

Figure 1 Bus Buffer Delay

### Busy flag

When the Busy flag is logical 1, the SED1520 series is executing its internal operations. Any command other than Status Read is rejected during this time. The Busy flag is output at pin D7 by the Status Read command. If an appropriate cycle time (tcyc) is given, this flag needs not be checked at the beginning of each command and, therefore, the MPU processing capacity can greatly be enhanced.

### Display Start Line and Line Count Registers

The contents of this register form a pointer to a line of data in display data RAM corresponding to the first line of the display (COM0), and are set by the Display Start Line command. See section 3.

The contents of the display start line register are copied into the line count register at the start of every frame, that is on each edge of FR. The line count register is incremented by the CL clock once for every display line, thus generating a pointer to the current line of data, in display data RAM, being transferred to the segment driver circuits.

### Column Address Counter

The column address counter is a 7-bit presettable counter that supplies the column address for MPU access to the display data RAM. See Figure 2. The counter is incremented by one every time the driver receives a Read or Write Display Data command. Addresses above 50H are invalid, and the counter will not increment past this value. The contents of the column address counter are set with the Set Column Address command.

### Page Register

The page register is a 2-bit register that supplies the page address for MPU access to the display data RAM. See Figure 2. The contents of the page register are set by the Set Page Register command.

### Display Data RAM

The display data RAM stores the LCD display data, on a 1-bit per pixel basis. The relationship between display data, display address and the display is shown in Figure 2.

**Common Timing Generator Circuit**

Generates common timing signals and FR frame signals from the CL basic clock. The 1/16 or 1/32 duty (for SED1520) or 1/8 or 1/16 duty (for SED1522) can be selected by the Duty Select command. If the 1/32 duty is selected for the SED1520 and 1/16 duty is selected for the SED1522, the 1/32 and 1/16 duties are provided by two chips consisting of the master and slave chips in the common multi-chip mode.

SED1520

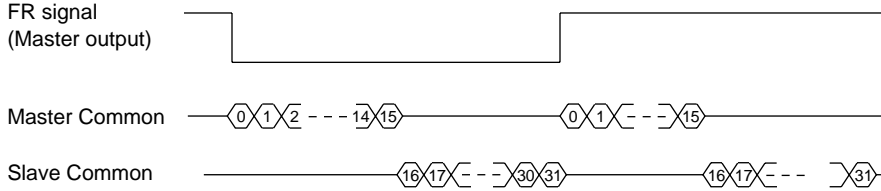

SED1522

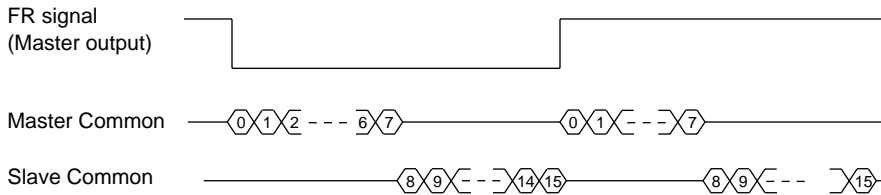

**Display Data Latch Circuit**

This latch stores one line of display data for use by the LCD driver interface circuitry. The output of this latch is controlled by the Display ON/OFF and Static Drive ON/OFF commands.

**LCD Driver Circuit**

The LCD driver circuitry generates the 80 4-level signals used to drive the LCD panel, using output from the display data latch and the common timing generator circuitry.

**Display Timing Generator**

This circuit generates the internal display timing signal using the basic clock, CL, and the frame signals, FR. FR is used to generate the dual frame AC-drive waveform (type B drive) and to lock the line counter and common timing generator to the system frame rate. CL is used to lock the line counter to the system line scan rate. If a system uses both SED1520s or SED1522 and SED1521s they must have the same CL frequency rating.

### Oscillator Circuit (SED1520\*0A Only)

A low power-consumption CR oscillator for adjusting the oscillation frequency using Rf oscillation resistor only. This circuit generates a display timing signal. Some of SED1520 and SED1522 series models have a built-in oscillator and others use an external clock. This difference must be checked before use.

Connect the Rf oscillation resistor as follows. To suppress the built-in oscillator circuit and drive the MPU using an external clock, enter the clock having the same phase as the OSC2 of mater chip into OSC2 of the slave chip.

- MPU having a built-in oscillator

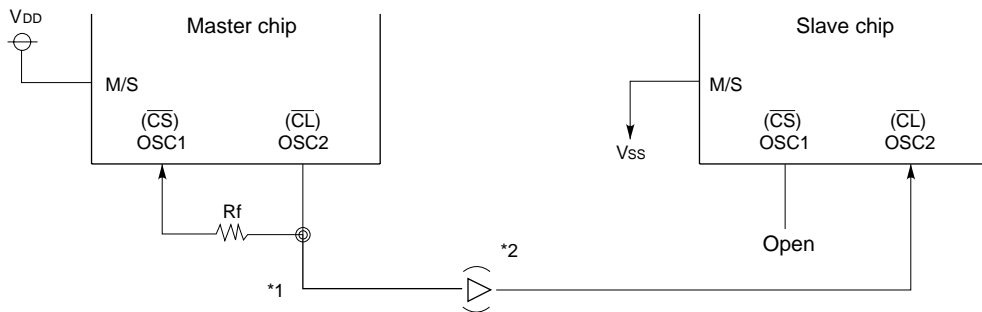

- \*1 If the parasitic capacitance of this section increases, the oscillation frequency may shift to the lower frequency. Therefore, the Rf oscillation frequency must be reduced below the specified level.
- \*2 A CMOS buffer is required if the oscillation circuit is connected to two or more slave MPU chips.

- MPU driven with an external clock



### Reset Circuit

Detects a rising or falling edge of an  $\overline{\text{RES}}$  input and initializes the MPU during power-on.

- Initialization status
  1. Display is off.
  2. Display start line register is set to line 1.
  3. Static drive is turned off.
  4. Column address counter is set to address 0.
  5. Page address register is set to page 3.
  6. 1/32 duty (SED1520) or 1/16 duty (SED1522) is selected.
  7. Forward ADC is selected (ADC command D0 is 1 and ADC status flag is 1).
  8. Read-modify-write is turned off.

The input signal level at  $\overline{\text{RES}}$  pin is sensed, and an MPU interface mode is selected as shown on Table 1. For the 80-series MPU, the  $\overline{\text{RES}}$  input is passed through the inverter and the active high reset signal must be entered. For the 68-series MPU, the active low reset signal must be entered.

As shown for the MPU interface (reference example), the  $\overline{\text{RES}}$  pin must be connected to the Reset pin and reset at the same time as the MPU initialization.

If the MPU is not initialized by the use of  $\overline{\text{RES}}$  pin during power-on, an unrecoverable MPU failure may occur.

When the Reset command is issued, initialization

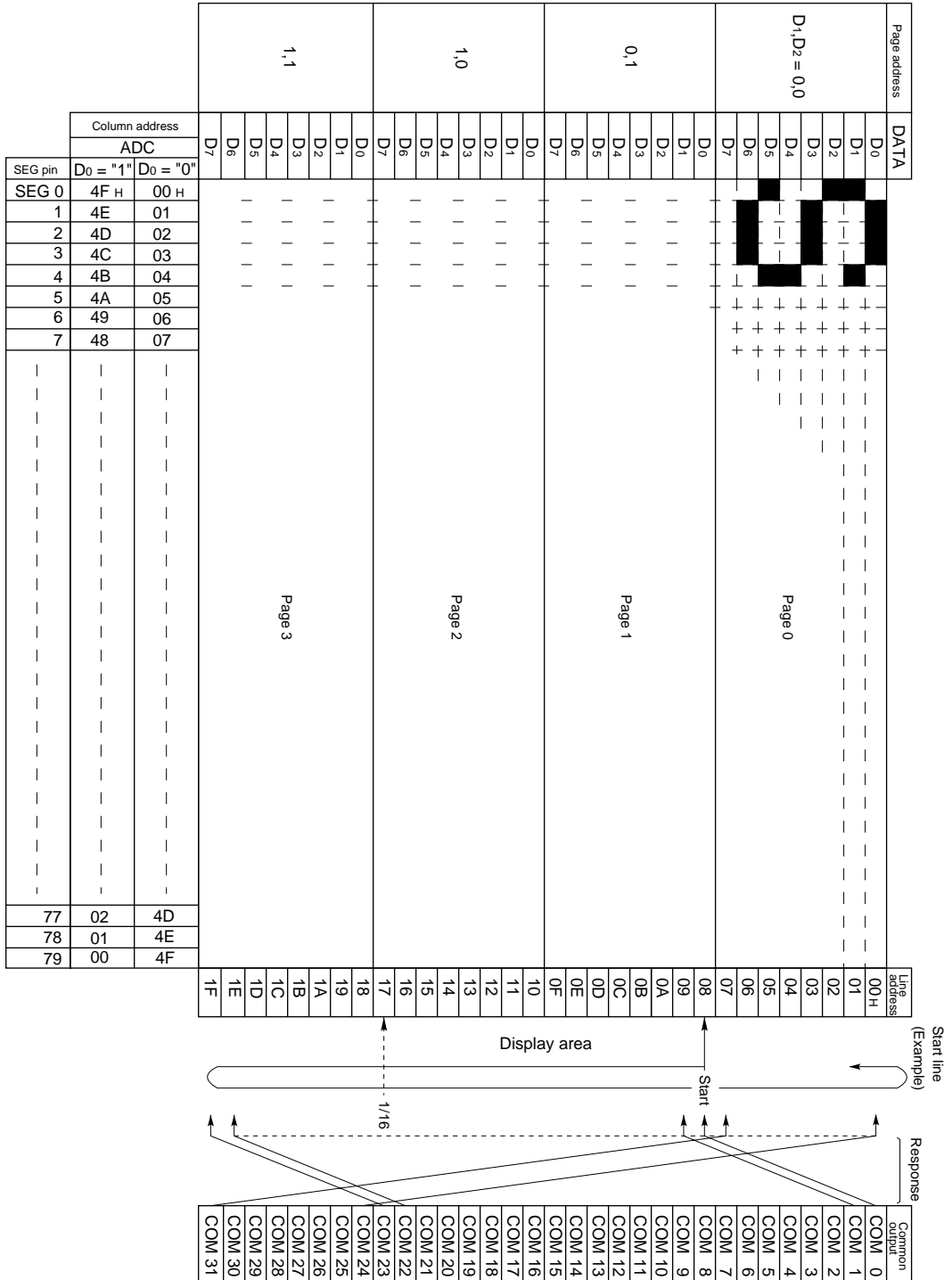
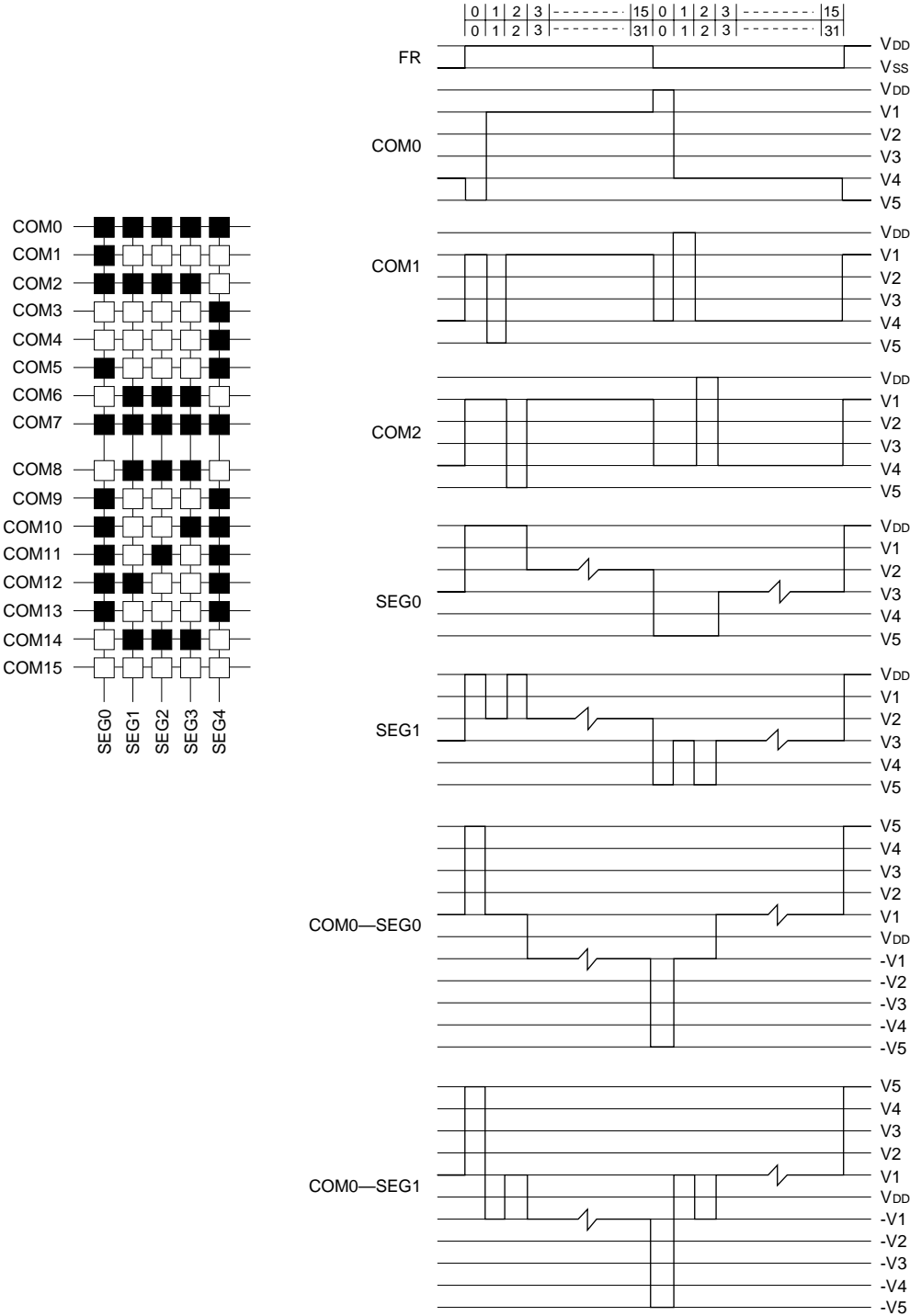

Figure 2 Display Data RAM Addressing

1/5 bias, 1/16 duty  
 1/6 bias, 1/32 duty



SED1520 Series

Figure 4 LCD drive waveforms example

**COMMANDS**

**Summary**

Command	Code											Function
	A0	RD	WR	D7	D6	D5	D4	D3	D2	D1	D0	
Display On/OFF	0	1	0	1	0	1	0	1	1	1	0/1	Turns display on or off. 1: ON, 0: OFF
Display start line	0	1	0	1	1	0	Display start address (0 to 31)					Specifies RAM line corresponding to top line of display.
Set page address	0	1	0	1	0	1	1	1	0	Page (0 to 3)		Sets display RAM page in page address register.
Set column (segment) address	0	1	0	0	Column address (0 to 79)							Sets display RAM column address in column address register.
Read status	0	0	1	Busy	ADC	ON/OFF	Reset	0	0	0	0	Reads the following status: BUSY     1: Busy 0: Ready ADC       1: CW output 0: CCW output ON/OFF    1: Display off 0: Display on RESET     1: Being reset 0: Normal
Write display data	1	1	0	Write data								Writes data from data bus into display RAM.
Read display data	1	0	1	Read data								Reads data from display RAM onto data bus.
Select ADC	0	1	0	1	0	1	0	0	0	0	0/1	0: CW output, 1: CCW output
Static drive ON/OFF	0	1	0	1	0	1	0	0	1	0	0/1	Selects static driving operation. 1: Static drive, 0: Normal driving
Select duty	0	1	0	1	0	1	0	1	0	0	0/1	Selects LCD duty cycle 1: 1/32, 0: 1/16
Read-Modify-Write	0	1	0	1	1	1	0	0	0	0	0	Read-modify-write ON
End	0	1	0	1	1	1	0	1	1	1	0	Read-modify-write OFF
Reset	0	1	0	1	1	1	0	0	0	1	0	Software reset

### Command Description

Table 3 is the command table. The SED1520 series identifies a data bus using a combination of A0 and R/W ( $\overline{RD}$  or  $\overline{WR}$ ) signals. As the MPU translates a command in the internal timing only (independent from the external clock), its speed is very high. The busy check is usually not required.

#### Display ON/OFF

A0	$\overline{RD}$	$\overline{R/W}$ $\overline{WR}$	D7	D6	D5	D4	D3	D2	D1	D0	
0	1	0	1	0	1	0	1	1	1	D	AEH, AFH

This command turns the display on and off.

- D=1: Display ON
- D=0: Display OFF

#### Display Start Line

This command specifies the line address shown in Figure 3 and indicates the display line that corresponds to COM0. The display area begins at the specified line address and continues in the line address increment direction. This area having the number of lines of the specified display duty is displayed. If the line address is changed dynamically by this command, the vertical smooth scrolling and paging can be used.

A0	$\overline{RD}$	$\overline{R/W}$ $\overline{WR}$	D7	D6	D5	D4	D3	D2	D1	D0	
0	1	0	1	1	0	A4	A3	A2	A1	A0	C0H to DFH

This command loads the display start line register.

A4	A3	A2	A1	A0	Line Address
0	0	0	0	0	0
0	0	0	0	1	1
		:			:
		:			:
1	1	1	1	1	31

See Figure 2.

#### Set Page Address

This command specifies the page address that corresponds to the low address of the display data RAM when it is accessed by the MPU. Any bit of the display data RAM can be accessed when its page address and column address are specified. The display status is not changed even when the page address is changed.

A0	$\overline{RD}$	$\overline{R/W}$ $\overline{WR}$	D7	D6	D5	D4	D3	D2	D1	D0	
0	1	0	1	0	1	1	1	0	A1	A0	B8H to BBH

This command loads the page address register.

A1	A0	Page
0	0	0
0	1	1
1	0	2
1	1	3

See Figure 2.



**Set Column Address**

This command specifies a column address of the display data RAM. When the display data RAM is accessed by the MPU continuously, the column address is incremented by 1 each time it is accessed from the set address. Therefore, the MPU can access to data continuously. The column address stops to be incremented at address 80, and the page address is not changed continuously.

A <sub>0</sub>	$\overline{RD}$	$\overline{R/W}$ WR	D <sub>7</sub>	D <sub>6</sub>	D <sub>5</sub>	D <sub>4</sub>	D <sub>3</sub>	D <sub>2</sub>	D <sub>1</sub>	D <sub>0</sub>	
0	1	0	0	A <sub>6</sub>	A <sub>5</sub>	A <sub>4</sub>	A <sub>3</sub>	A <sub>2</sub>	A <sub>1</sub>	A <sub>0</sub>	00H to 4FH

This command loads the column address register.

A <sub>6</sub>	A <sub>5</sub>	A <sub>4</sub>	A <sub>3</sub>	A <sub>2</sub>	A <sub>1</sub>	A <sub>0</sub>	Column Address
0	0	0	0	0	0	0	0
0	0	0	0	0	0	1	1
			⋮				⋮
			⋮				⋮
1	0	0	1	1	1	1	79

**Read Status**

A <sub>0</sub>	$\overline{RD}$	$\overline{R/W}$ WR	D <sub>7</sub>	D <sub>6</sub>	D <sub>5</sub>	D <sub>4</sub>	D <sub>3</sub>	D <sub>2</sub>	D <sub>1</sub>	D <sub>0</sub>
0	0	1	BUSY	ADC	ON/OFF	RESET	0	0	0	0

Reading the command I/O register (A<sub>0</sub>=0) yields system status information.

- The busy bit indicates whether the driver will accept a command or not.  
 Busy=1: The driver is currently executing a command or is resetting. No new command will be accepted.  
 Busy=0: The driver will accept a new command.
- The ADC bit indicates the way column addresses are assigned to segment drivers.  
 ADC=1: Normal. Column address n → segment driver n.  
 ADC=0: Inverted. Column address 79-u → segment driver u.
- The ON/OFF bit indicates the current status of the display.  
 It is the inverse of the polarity of the display ON/OFF command.  
 ON/OFF=1: Display OFF  
 ON/OFF=0: Display ON
- The RESET bit indicates whether the driver is executing a hardware or software reset or if it is in normal operating mode.  
 RESET=1: Currently executing reset command.  
 RESET=0: Normal operation

**Write Display Data**

A <sub>0</sub>	$\overline{RD}$	$\overline{R/W}$ WR	D <sub>7</sub>	D <sub>6</sub>	D <sub>5</sub>	D <sub>4</sub>	D <sub>3</sub>	D <sub>2</sub>	D <sub>1</sub>	D <sub>0</sub>
1	1	0	Write data							

Writes 8-bits of data into the display data RAM, at a location specified by the contents of the column address and page address registers and then increments the column address register by one.

**Read Display Data**

A <sub>0</sub>	$\overline{\text{RD}}$	$\frac{\text{R}}{\text{W}}$ $\frac{\text{WR}}$	D <sub>7</sub>	D <sub>6</sub>	D <sub>5</sub>	D <sub>4</sub>	D <sub>3</sub>	D <sub>2</sub>	D <sub>1</sub>	D <sub>0</sub>
1	0	1	Read data							

Reads 8-bits of data from the data I/O latch, updates the contents of the I/O latch with display data from the display data RAM location specified by the contents of the column address and page address registers and then increments the column address register.

After loading a new address into the column address register one dummy read is required before valid data is obtained.

**Select ADC**

A <sub>0</sub>	$\overline{\text{RD}}$	$\frac{\text{R}}{\text{W}}$ $\frac{\text{WR}}$	D <sub>7</sub>	D <sub>6</sub>	D <sub>5</sub>	D <sub>4</sub>	D <sub>3</sub>	D <sub>2</sub>	D <sub>1</sub>	D <sub>0</sub>
0	1	0	1	0	1	0	0	0	0	D

A0H, A1H

This command selects the relationship between display data RAM column addresses and segment drivers.

D=1: SEG0 ← column address 4FH, ... (inverted)

D=0: SEG0 ← column address 00H, ... (normal)

This command is provided to reduce restrictions on the placement of driver ICs and routing of traces during printed circuit board design. See Figure 2 for a table of segments and column addresses for the two values of D.

**Static Drive ON/OFF**

A <sub>0</sub>	$\overline{\text{RD}}$	$\frac{\text{R}}{\text{W}}$ $\frac{\text{WR}}$	D <sub>7</sub>	D <sub>6</sub>	D <sub>5</sub>	D <sub>4</sub>	D <sub>3</sub>	D <sub>2</sub>	D <sub>1</sub>	D <sub>0</sub>
0	1	0	1	0	1	0	0	1	0	D

A4H, A5H

Forces display on and all common outputs to be selected.

D=1: Static drive on

D=0: Static drive off

**Select Duty**

A <sub>0</sub>	$\overline{\text{RD}}$	$\frac{\text{R}}{\text{W}}$ $\frac{\text{WR}}$	D <sub>7</sub>	D <sub>6</sub>	D <sub>5</sub>	D <sub>4</sub>	D <sub>3</sub>	D <sub>2</sub>	D <sub>1</sub>	D <sub>0</sub>
0	1	0	1	0	1	0	1	0	0	D

A8H, A9H

This command sets the duty cycle of the LCD drive and is only valid for the SED1520F and SED1522F. It is invalid for the SED1521F which performs passive operation. The duty cycle of the SED1521F is determined by the externally generated FR signal.

SED1520 SED1522

D=1: 1/32 duty cycle 1/16 duty cycle

D=0: 1/16 duty cycle 1/8 duty cycle

When using the SED1520F<sub>0A</sub>, SED1522F<sub>0A</sub> (having a built-in oscillator) and the SED1521F<sub>0A</sub> continuously, set the duty as follows:

	SED1521F <sub>0A</sub>	
SED1520F <sub>0A</sub>	1/32	1/32
	1/16	1/16
SED1522F <sub>0A</sub>	1/16	1/32
	1/8	1/16

**Read-Modify-Write**

A <sub>0</sub>	$\overline{RD}$	$\frac{R}{W}$ $\overline{WR}$	D <sub>7</sub>	D <sub>6</sub>	D <sub>5</sub>	D <sub>4</sub>	D <sub>3</sub>	D <sub>2</sub>	D <sub>1</sub>	D <sub>0</sub>	E0H
0	1	0	1	1	1	0	0	0	0	0	

This command defeats column address register auto-increment after data reads. The current contents of the column address register are saved. This mode remains active until an End command is received.

- Operation sequence during cursor display

When the End command is entered, the column address is returned to the one used during input of Read-Modify-Write command. This function can reduce the load of MPU when data change is repeated at a specific display area (such as cursor blinking).

\* Any command other than Data Read or Write can be used in the Read-Modify-Write mode. However, the Column Address Set command cannot be used.

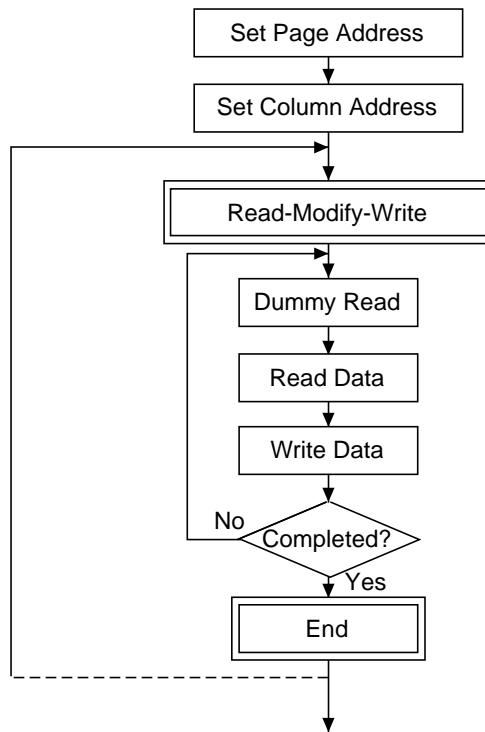

**End**

A <sub>0</sub>	$\overline{RD}$	$\frac{R}{W}$ $\overline{WR}$	D <sub>7</sub>	D <sub>6</sub>	D <sub>5</sub>	D <sub>4</sub>	D <sub>3</sub>	D <sub>2</sub>	D <sub>1</sub>	D <sub>0</sub>	EEH
0	1	0	1	1	1	0	1	1	1	0	

This command cancels read-modify-write mode and restores the contents of the column address register to their value prior to the receipt of the Read-Modify-Write command.

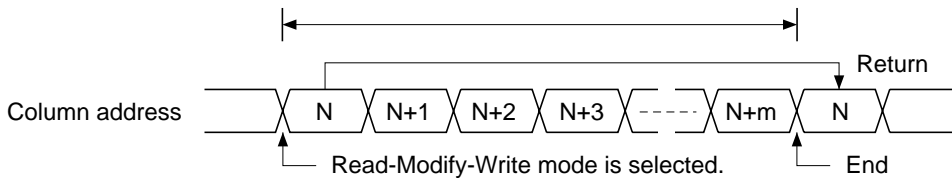

**Reset**

A0	$\overline{RD}$	$\overline{R/W}$ $\overline{WR}$	D7	D6	D5	D4	D3	D2	D1	D0	
0	1	0	1	1	1	0	0	0	1	0	E2H

This command clears

- the display start line register.
- and set page address register to 3 page.

It does not affect the contents of the display data RAM.

When the power supply is turned on, a Reset signal is entered in the  $\overline{RES}$  pin. The Reset command cannot be used instead of this Reset signal.

**Power Save (Combination command)**

The Power Save mode is selected if the static drive is turned ON when the display is OFF. The current consumption can be reduced to almost the static current level. In the Power Save mode:

- The LCD drive is stopped, and the segment and common driver outputs are set to the  $V_{DD}$  level.
- The external oscillation clock input is inhibited, and the OSC2 is set to the floating mode.
- The display and operation modes are kept.

The Power Save mode is released when the display is turned ON or when the static drive is turned OFF. If the LCD drive voltage is supplied from an external resistance divider circuit, the current passing through this resistor must be cut by the Power Save signal.

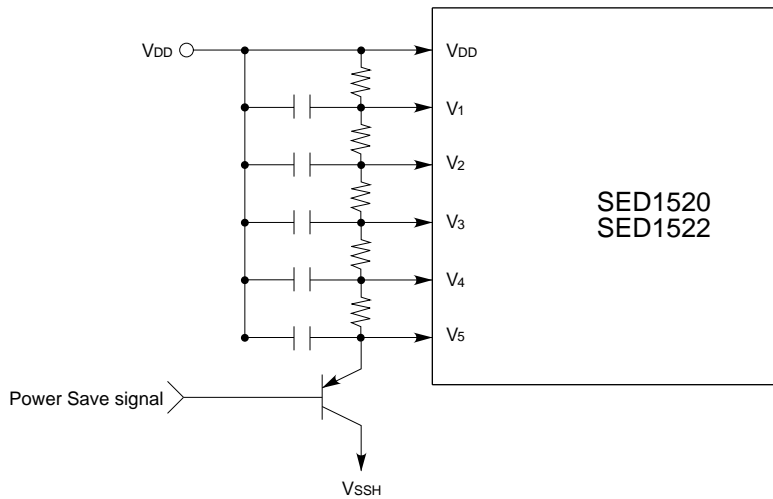

If the LCD drive power is generated by resistance division, the resistance and capacitance are determined by the LCD panel size. After the panel size has been determined, reduce the resistance to the level where the display quality is not affected and reduce the power consumption using the divider resistor.

**SPECIFICATIONS**

**Absolute Maximum Ratings**

Parameter	Symbol	Rating	Unit
Supply voltage (1)	V <sub>SS</sub>	-8.0 to +0.3	V
Supply voltage (2)	V <sub>5</sub>	-16.5 to +0.3	V
Supply voltage (3)	V <sub>1</sub> , V <sub>4</sub> , V <sub>2</sub> , V <sub>3</sub>	V <sub>5</sub> to +0.3	V
Input voltage	V <sub>IN</sub>	V <sub>SS</sub> -0.3 to +0.3	V
Output voltage	V <sub>O</sub>	V <sub>SS</sub> -0.3 to +0.3	V
Power dissipation	P <sub>D</sub>	250	mW
Operating temperature	T <sub>opr</sub>	-40 to +85	deg. C
Storage temperature	T <sub>stg</sub>	-65 to +150	deg. C
Soldering temperature time at lead	T <sub>sol</sub>	260, 10	deg. C, sec

- Notes:**
1. All voltages are specified relative to V<sub>DD</sub> = 0 V.
  2. The following relation must be always hold  
V<sub>DD</sub> ≥ V<sub>1</sub> ≥ V<sub>2</sub> ≥ V<sub>3</sub> ≥ V<sub>4</sub> ≥ V<sub>5</sub>
  3. Exceeding the absolute maximum ratings may cause permanent damage to the device. Functional operation under these conditions is not implied.
  4. Moisture resistance of flat packages can be reduced by the soldering process, so care should be taken to avoid thermally stressing the package during board assembly.

**Electrical Specifications**

**DC Characteristics**

T<sub>a</sub> = -20 to 75 deg. C, V<sub>DD</sub> = 0 V unless stated otherwise

Parameter		Symbol	Condition	Rating			Unit	Applicable Pin	
				Min.	Typ.	Max.			
Operating voltage (1) See note 1.	Recommended	V <sub>SS</sub>		-5.5	-5.0	-4.5	V	V <sub>SS</sub>	
	Allowable			-7.0	—	-2.4			
Operating voltage (2)	Recommended	V <sub>5</sub>		-13.0	—	-3.5	V	V <sub>5</sub> See note 10.	
	Allowable			-13.0	—	—			
	Allowable	V <sub>1</sub> , V <sub>2</sub>		0.6×V <sub>5</sub>	—	V <sub>DD</sub>	V	V <sub>1</sub> , V <sub>2</sub>	
	Allowable	V <sub>3</sub> , V <sub>4</sub>		V <sub>5</sub>	—	0.4×V <sub>5</sub>	V	V <sub>3</sub> , V <sub>4</sub>	
High-level input voltage		V <sub>IHT</sub>		V <sub>SS</sub> +2.0	—	V <sub>DD</sub>	V	See note 2 & 3.	
		V <sub>IHC</sub>		0.2×V <sub>SS</sub>	—	V <sub>DD</sub>			
		V <sub>IHT</sub>	V <sub>SS</sub> = -3 V		0.2×V <sub>SS</sub>	—		V <sub>DD</sub>	See note 2 & 3.
		V <sub>IHC</sub>	V <sub>SS</sub> = -3 V		0.2×V <sub>SS</sub>	—		V <sub>DD</sub>	
Low-level input voltage		V <sub>ILT</sub>		V <sub>SS</sub>		V <sub>SS</sub> +0.8	V	See note 2 & 3.	
		V <sub>ILC</sub>		V <sub>SS</sub>		0.8×V <sub>SS</sub>			
		V <sub>ILT</sub>	V <sub>SS</sub> = -3 V		V <sub>SS</sub>			0.85×V <sub>SS</sub>	See note 2 & 3.
		V <sub>ILC</sub>	V <sub>SS</sub> = -3 V		V <sub>SS</sub>			0.8×V <sub>SS</sub>	
High-level output voltage		V <sub>OHT</sub>	I <sub>OH</sub> = -3.0 mA	V <sub>SS</sub> +2.4	—	—	V	OSC2 See note 4 & 5.	
		V <sub>OHC1</sub>	I <sub>OH</sub> = -2.0 mA	V <sub>SS</sub> +2.4	—	—			
		V <sub>OHC2</sub>	I <sub>OH</sub> = -120 μA	0.2×V <sub>SS</sub>	—	—			
		V <sub>OHT</sub>	V <sub>SS</sub> = -3 V	I <sub>OH</sub> = -2 mA	0.2×V <sub>SS</sub>			V	See note 4 & 5. OSC2
		V <sub>OHC1</sub>	V <sub>SS</sub> = -3 V	I <sub>OH</sub> = -2 mA	0.2×V <sub>SS</sub>				
		V <sub>OHC2</sub>	V <sub>SS</sub> = -3 V	I <sub>OH</sub> = -50 μA	0.2×V <sub>SS</sub>				

(continued)

**DC Characteristics (Cont'd)**

Ta = -20 to 75 deg. C, VDD = 0 V unless stated otherwise

Parameter	Symbol	Condition		Rating			Unit	Applicable Pin
				Min.	Typ.	Max.		
Low-level output voltage	VOLT	IOL = 3.0 mA		—	—	VSS+0.4	V	OSC2 See note 4 & 5.
	VOLC1	IOL = 2.0 mA		—	—	VSS+0.4		
	VOLC2	IOL = 120 μA		—	—	0.8×VSS		
	VOLT	VSS = -3 V	IOL = 2 mA			0.8×VSS	V	See note 4 & 5. OSC2
	VOLC1	VSS = -3 V	IOL = 2 mA			0.8×VSS		
	VOLC2	VSS = -3 V	IOL = 50 μA			0.8×VSS		
Input leakage current	ILI			-1.0	—	1.0	μA	See note 6.
Output leakage current	ILO			-3.0	—	3.0	μA	See note 7.
LCD driver ON resistance	RON	Ta = 25 deg. C	V5 = -5.0 V	—	5.0	7.5	kΩ	SEG0 to 79, COM0 to 15, See note 11
			V5 = -3.5 V	—	10.0	50.0		
Static current dissipation	IDDO	CS = CL = VDD		—	0.05	1.0	μA	VDD
Dynamic current dissipation	IDD (1)	During display V5 = -5.0 V	fCL = 2 kHz	—	2.0	5.0	μA	VDD See note 12, 13 & 14.
			Rf = 1 MΩ	—	9.5	15.0		
			fCL = 18 kHz	—	5.0	10.0		
		During display V5 = -5 V VSS = -3 V	fCL = 2 kHz		1.5	4.5	μA	VDD See note 12 & 13.
			Rf = 1 MΩ		6.0	12.0		
		IDD (2)	During access t <sub>cy</sub> = 200 kHz		—	300	500	μA
VSS = -3V, During access t <sub>cy</sub> = 200 kHz				150	300			
Input pin capacitance	CIN	Ta = 25 deg. C, f = 1 MHz		—	5.0	8.0	pF	All input pins
Oscillation frequency	fOSC	Rf = 1.0 MΩ ±2%, VSS = -5.0 V		15	18	21	kHz	See note 9.
		Rf = 1.0 MΩ ±2%, VSS = -3.0 V		11	16	21		
Reset time	tR			1.0	—		μS	RES See note 15.

- Notes:**
1. Operation over the specified voltage range is guaranteed, except where the supply voltage changes suddenly during CPU access.
  2. A0, D0 to D7, E (or RD), R/W (or WR) and CS
  3. CL, FR, M/S and RES
  4. D0 to D7
  5. FR
  6. A0, E (or RD), R/W (or WR), CS, CL, M/S and RES
  7. When D0 to D7 and FR are high impedance.
  8. During continual write access at a frequency of t<sub>cy</sub>. Current consumption during access is effectively proportional to the access frequency.
  9. See figure below for details
  10. See figure below for details
  11. For a voltage differential of 0.1 V between input (V1, ..., V4) and output (COM, SEG) pins. All voltages within specified operating voltage range.
  12. SED1520\*A\* and SED1521\*A\* and SED1522\*A\* only. Does not include transient currents due to stray and panel capacitances.
  13. SED1520\*0\* and SED1522\*0\* only. Does not include transient currents due to stray and panel capacitances.
  14. SED1521\*0\* only. Does not include transient currents due to stray and panel capacitances.
  15. tR (Reset time) represents the time from the RES signal edge to the completion of reset of the internal circuit. Therefore, the SED1520 series enters the normal operation status after this tR.

Relationship between fosc, fFR and Rf, and operating bounds on Vss and V5

- \*9 • Relationship between oscillation frequency, frames and Rf (SED1520F0A), (SED1522F0A)

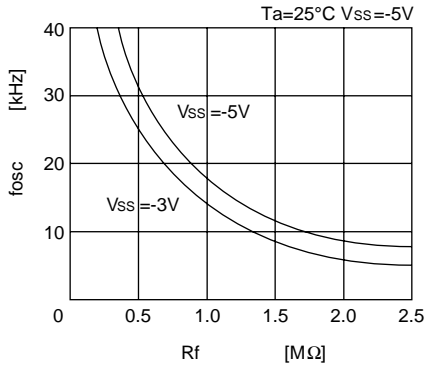

Figure 5 (a)

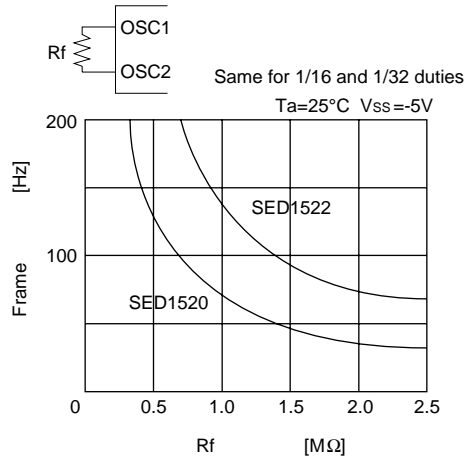

Figure 5 (b)

- Relationship between external clocks (fCL) and frames (SED1520FAA), (SED1522FAA)

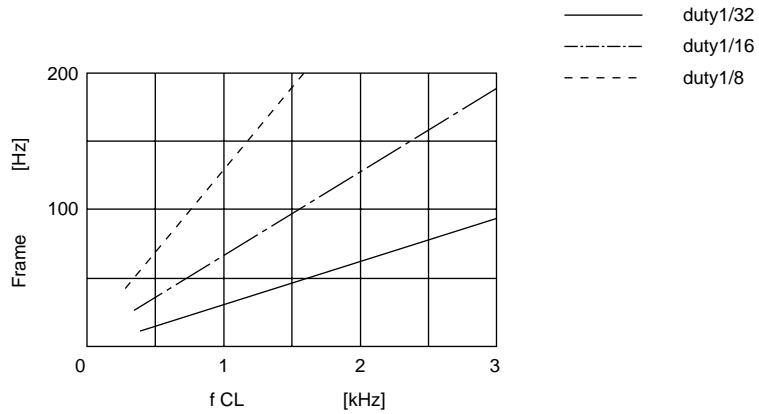

Figure 5 (c)

- \*10 • Operating voltage range of Vss and V5 systems

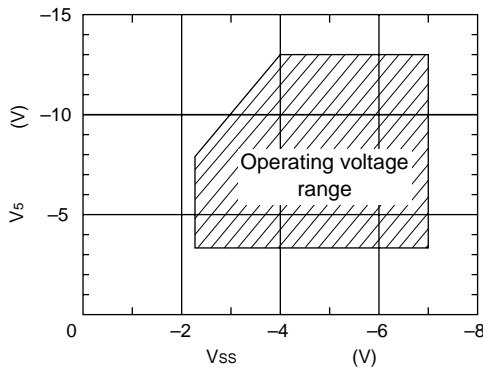
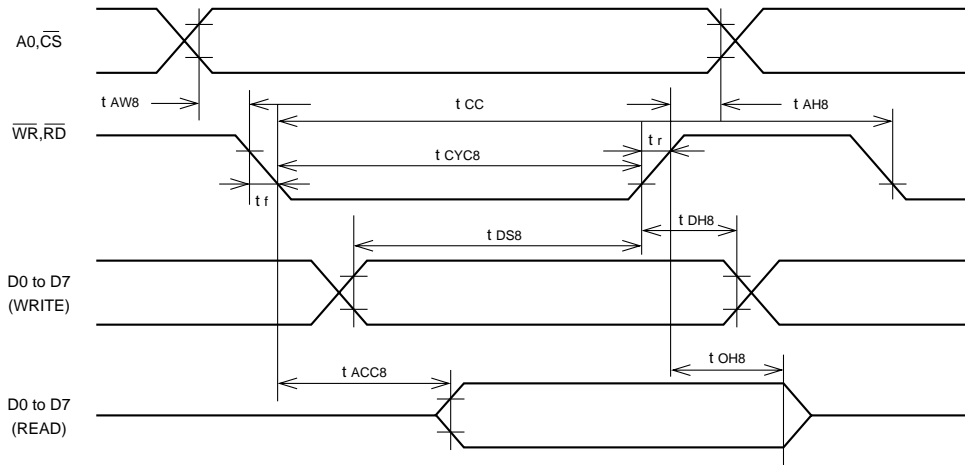

Figure 6

AC Characteristics

- MPU Bus Read/Write I (80-family MPU)



Ta = -20 to 75 deg. C, Vss = -5.0 V ±10% unless stated otherwise

Parameter	Symbol	Condition	Rating		Unit	Signal
			Min.	Max.		
Address hold time	tAH8		10	—	ns	A0, $\overline{CS}$
Address setup time	tAW8		20	—	ns	
System cycle time	tCYC8		1000	—	ns	$\overline{WR}$ , $\overline{RD}$
Control pulsewidth	tCC		200	—	ns	
Data setup time	tDS8		80	—	ns	D0 to D7
Data hold time	tDH8		10	—	ns	
RD access time	tACC8	CL = 100 pF	—	90	ns	
Output disable time	tCH8		10	60	ns	
Rise and fall time	tr, tf	—	—	15	ns	

(Vss = -2.7 to -4.5 V, Ta = -20 to +75°C)

Parameter	Symbol	Condition	Rating		Unit	Signal
			Min.	Max.		
Address hold time	tAH8	—	20	—	ns	A0, $\overline{CS}$
Address setup time	tAW8		40	—	ns	
System cycle time	tCYC8	—	2000	—	ns	$\overline{WR}$ , $\overline{RD}$
Control pulse width	tCC		400	—	ns	
Data setup time	tDS8	—	160	—	ns	D0 to D7
Data hold time	tDH8		20	—	ns	
RD access time	tACC8	CL = 100 pF	—	180	ns	
Output disable time	tCH8		20	120	ns	
Rise and fall time	tr, tf	—	—	15	ns	



## SED1520 Series

- MPU Bus Read/Write II (68-family MPU)

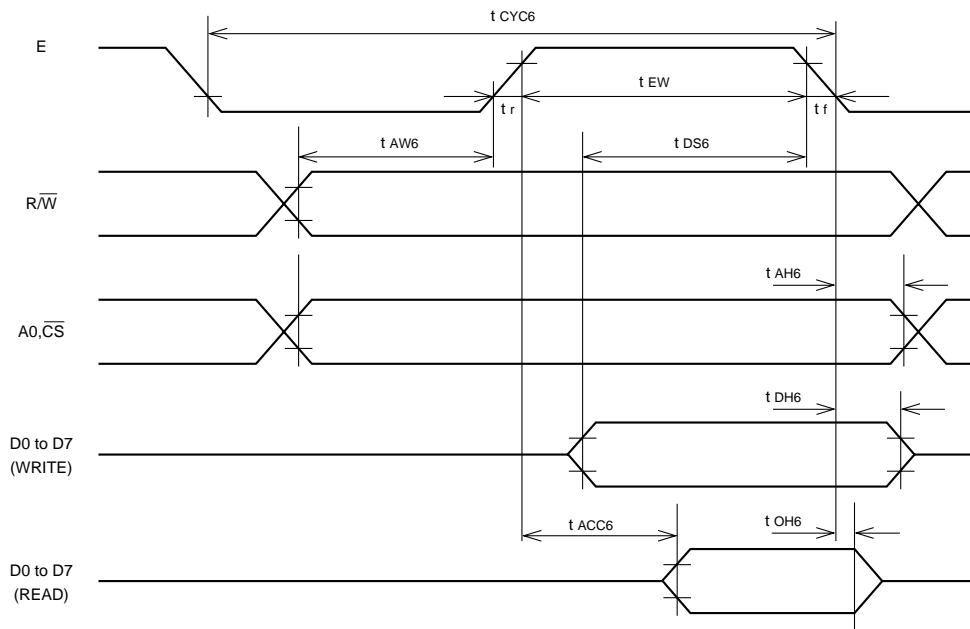

$T_a = -20$  to  $75$  deg. C,  $V_{SS} = -5$  V  $\pm 10$  unless stated otherwise

Parameter	Symbol	Condition	Rating		Unit	Signal
			Min.	Max.		
System cycle time	$t_{CYC6}$		1000	—	ns	A0, $\overline{CS}$ , $\overline{R/W}$
Address setup time	$t_{AW6}$		20	—	ns	
Address hold time	$t_{AH6}$		10	—	ns	
Data setup time	$t_{DS6}$		80	—	ns	D0 to D7
Data hold time	$t_{DH6}$		10	—	ns	
Output disable time	$t_{OH6}$	CL = 100 pF	10	60	ns	
Access time	$t_{ACC6}$		—	90	ns	
Enable pulsewidth	Read	$t_{EW}$	100	—	ns	E
	Write		80	—	ns	
Rise and fall time	$t_r, t_f$	—	—	15	ns	—

( $V_{SS} = -2.7$  to  $-4.5$  V,  $T_a = -20$  to  $+75^\circ\text{C}$ )

Parameter	Symbol	Condition	Rating		Unit	Signal
			Min.	Max.		
System cycle time <sup>*1</sup>	$t_{CYC6}$	—	2000	—	ns	A0, $\overline{CS}$ , $\overline{R/W}$
Address setup time	$t_{AW6}$	—	40	—	ns	
Address hold time	$t_{AH6}$	—	20	—	ns	
Data setup time	$t_{DS6}$	—	160	—	ns	D0 to D7
Data hold time	$t_{DH6}$	—	20	—	ns	
Output disable time	$t_{OH6}$	CL = 100 pF	20	120	ns	
Access time	$t_{ACC6}$		—	180	ns	
Enable pulse width	Read	$t_{EW}$	200	—	ns	E
	Write		160	—	ns	
Rise and fall time	$t_r, t_f$	—	—	15	ns	—

**Notes:** 1.  $t_{CYC6}$  is the cycle time of  $\overline{CS}$ . E = H, not the cycle time of E.

• Display Control Signal Timing

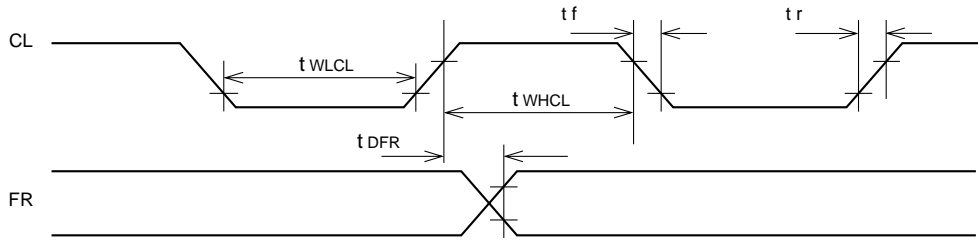

**Input**

Ta = -20 to 75 deg. C, Vss = -5.0 V ±10% unless stated otherwise

Parameter	Symbol	Condition	Rating			Unit	Signal
			Min.	Typ.	Max.		
Low-level pulsewidth	tWLCL		35	—	—	μs	CL
High-level pulsewidth	tWHCL		35	—	—	μs	
Rise time	tr		—	30	150	ns	
Fall time	tf		—	30	150	ns	
FR delay time	tDFR		-2.0	0.2	2.0	μs	FR

Vss = -2.7 to -4.5 V, Ta = -20 to +75°C

Parameter	Symbol	Condition	Rating			Unit	Signal
			Min.	Typ.	Max.		
Low-level pulse width	tWLCL	—	70	—	—	μs	CL
High-level pulse width	tWHCL	—	70	—	—	μs	
Rise time	tr	—	—	60	300	ns	
Fall time	tf	—	—	60	300	ns	
FR delay time	tDFR	—	-4.0	0.4	4.0	μs	FR

**Note:** The listed input tDFR applies to the SED1520 and SED1521 and SED1522 in slave mode.

**Output**

Ta = -20 to 75 deg. C, Vss = -5.0 V ±10% unless stated otherwise

Parameter	Symbol	Condition	Rating			Unit	Signal
			Min.	Typ.	Max.		
FR delay time	tDFR	CL = 100 pF	—	0.2	0.4	μs	FR

Vss = -2.7 to -4.5 V, Ta = -20 to +75°C

Parameter	Symbol	Condition	Rating			Unit	Signal
			Min.	Typ.	Max.		
FR delay time	tDFR	CL = 100 pF	—	0.4	0.8	μs	FR

**Notes:** 1. The listed output tDFR applies to the SED1520 and SED1522 in master mode.

**APPLICATION NOTES**  
**MPU Interface Configuration**  
**80 Family MPU**

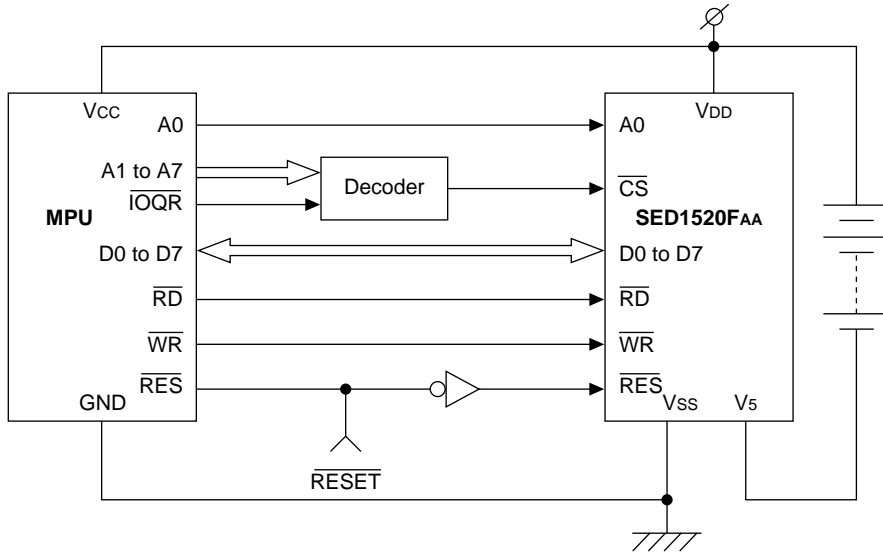

**LCD Drive Interface Configuration**

SED1520F0A–SED1520F0A

SED1522F0A–SED1522F0A

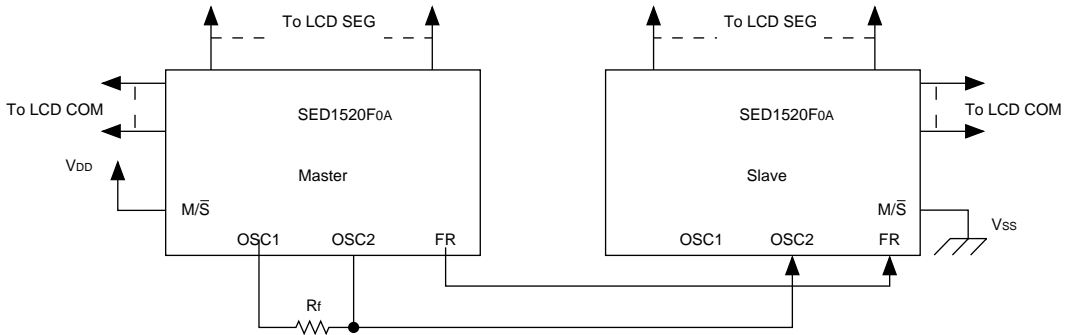

SED1520FAA–SED1520FAA

SED1522FAA–SED1522FAA

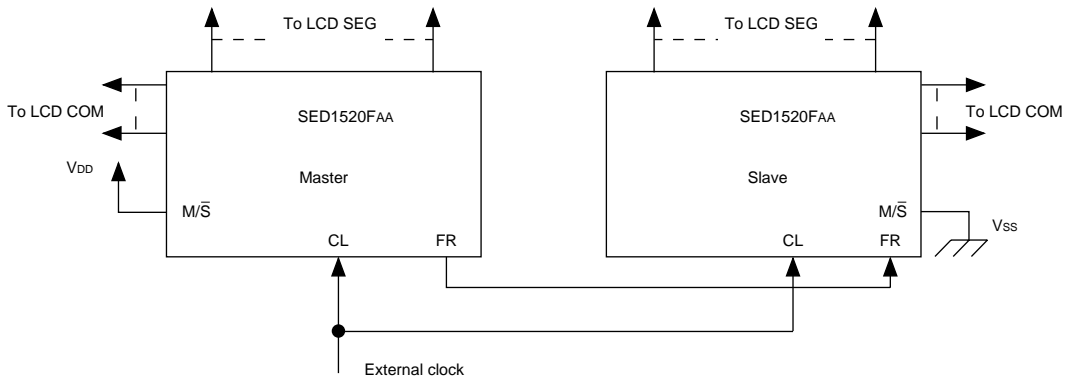

SED1520F0A )–SED1521F0A (See note 1)  
 SED1522F0A

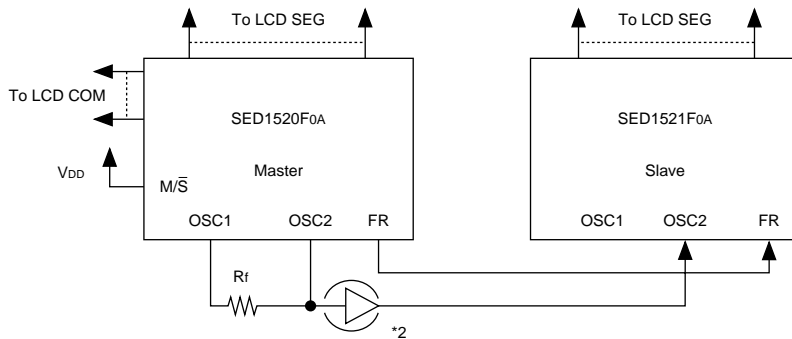

SED1520FAA–SED1521FAA

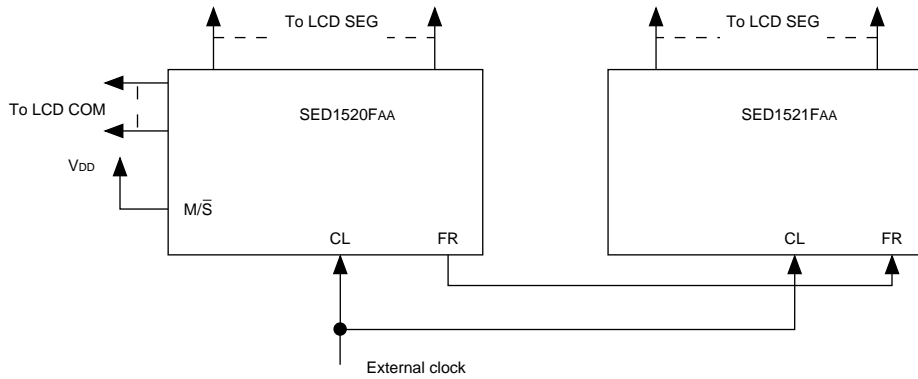

- Notes:**
1. The duty cycle of the slave must be the same as that for the master.
  2. If a system has two or more slave drivers a CMOS buffer will be required.

**LCD Panel Wiring Example (The full-dot LCD panel displays a character in 6x8 dots.)**

**1/16 duty:**

- 10 characters × 2 lines

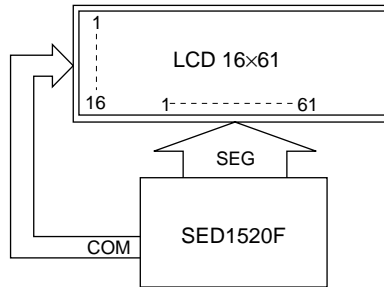

**1/16 duty:**

- 23 characters × 2 lines

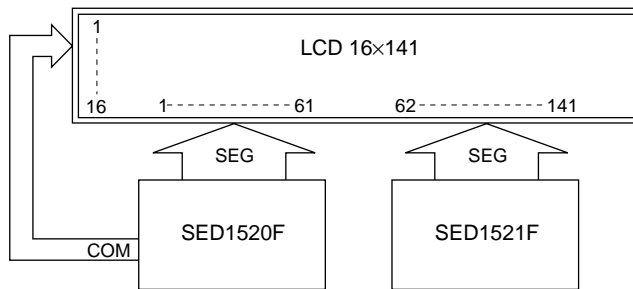

**1/32 duty:**

- 33 characters × 4 lines

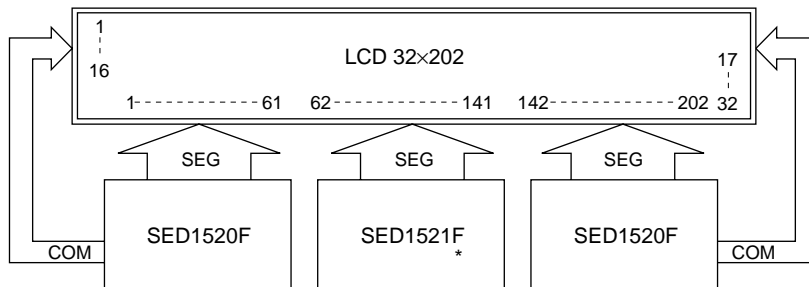

\* The SED1521F can be omitted (the 32x122-dot display mode is selected).

**Note:** A combination of AB or AA type chip (that uses internal clocks) and 0B or 0A type chip (that uses external clocks) is NOT allowed.

Package Dimensions

- Plastic QFP5–100 pin  
Dimensions: inches (mm)

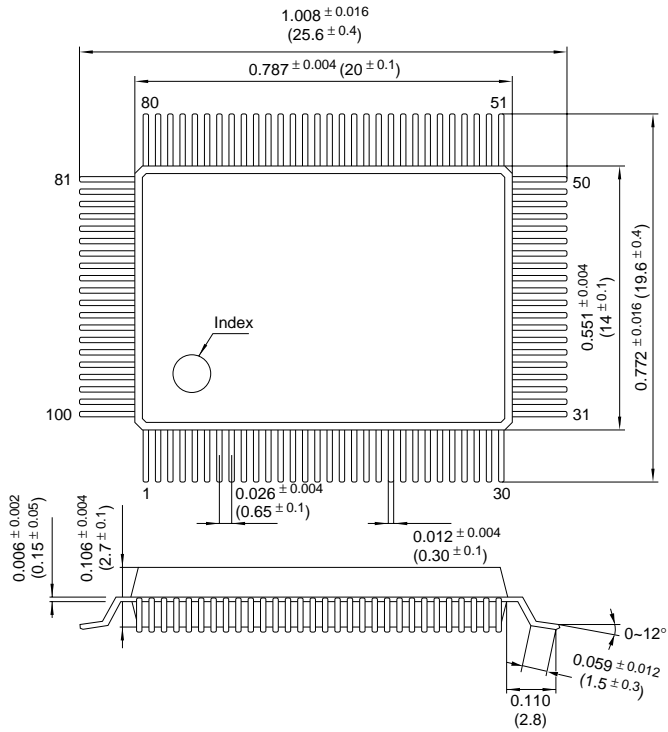

- Plastic QFP15–100 pin

