

# PRO-FORM® **QUIKLOCK** adjustable handweights

Model No. PFMC12330

Serial No. \_\_\_\_\_

Write the serial number in the space above for future reference.

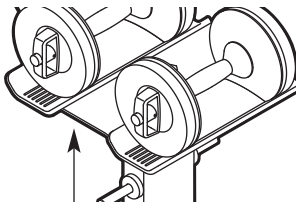

Serial Number Decal

## USER'S MANUAL

### QUESTIONS?

As a manufacturer, we are committed to providing complete customer satisfaction. If you have questions, or if there are missing or damaged parts, we will guarantee complete satisfaction through direct assistance from our factory.

TO AVOID DELAYS, PLEASE CALL DIRECT TO OUR TOLL-FREE CUSTOMER HOT LINE. The trained technicians on our customer hot line will provide immediate assistance, free of charge.

CUSTOMER HOT LINE:

**1-888-533-1333**

Mon.–Fri., 6 a.m.–6 p.m. MST

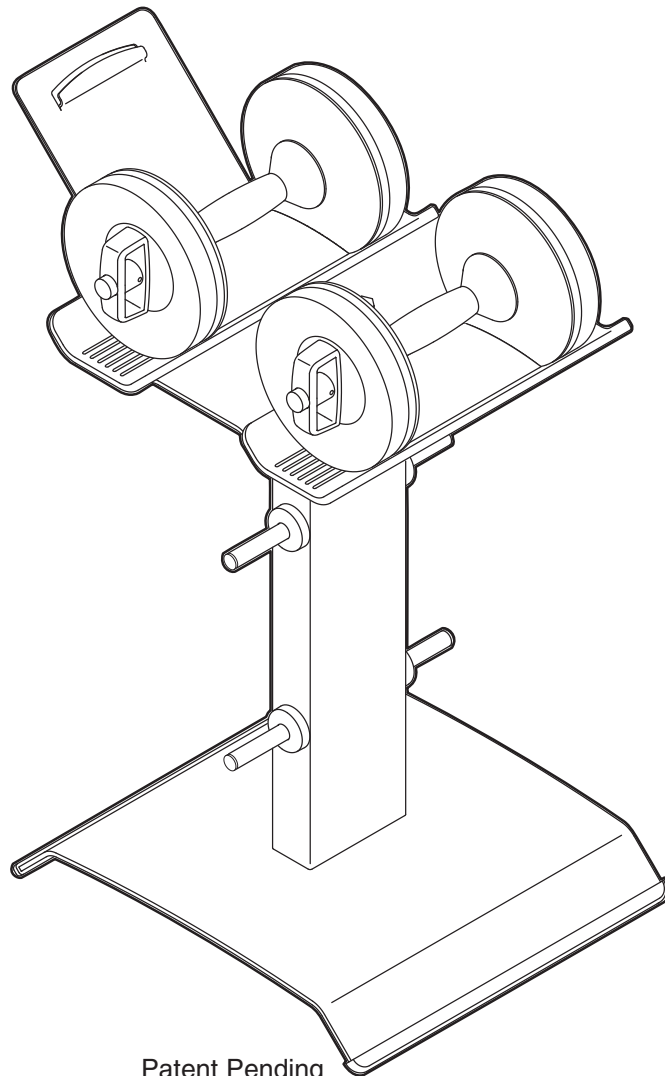

Patent Pending

### **⚠ CAUTION**

Read all precautions and instructions in this manual before using this equipment. Save this manual for future reference.



Visit our website at

**www.proform.com**

*new products, prizes,  
fitness tips, and much more!*

---

# TABLE OF CONTENTS

IMPORTANT PRECAUTIONS .....	2
BEFORE YOU BEGIN .....	3
ASSEMBLY .....	4
ADJUSTMENTS .....	6
PART LIST & EXPLODED DRAWING .....	7
ORDERING REPLACEMENT PARTS .....	Back Cover
LIMITED WARRANTY .....	Back Cover

---

## IMPORTANT PRECAUTIONS

**⚠ WARNING:** To reduce the risk of serious injury, read the following important precautions before using the adjustable handweights.

1. Read all instructions in this manual before using the adjustable handweights. Use the adjustable handweights only as described in this manual.
2. It is the responsibility of the owner to ensure that all users of the adjustable handweights are adequately informed of all precautions.
3. The adjustable handweights are intended for home use only. Do not use the adjustable handweights in any commercial, rental, or institutional setting.
4. Use the dumbbell tray only on a level surface. Cover the floor beneath the dumbbell tray to protect the floor.
5. Always wear athletic shoes for foot protection while exercising.
6. Make sure that all parts are properly tightened each time the adjustable handweights are used. Replace any worn parts immediately.
7. Keep children under 12 and pets away from the dumbbell tray at all times.
8. The dumbbell tray is designed to be used only with the included weight. Do not use any other weight with the dumbbell tray.
9. Attach weight plates to a handle only while the handle is on the tray or on the ground, and in the position shown. Do not hold the handle in a vertical position when adding or removing plates.
10. If you feel pain or dizziness at any time while exercising, stop immediately and begin cooling down.
11. Always lift the handweights using the handles. Do not lift the handweights by the lock handles.
12. The decal shown here has been placed on the dumbbell tray in the location shown on page 3. If the decal is missing or illegible, please call our Customer Service Department toll-free at 1-888-533-1333, Monday through Friday, 6 a.m. until 6 p.m. Mountain Time, to order a free replacement decal. Apply the decal in the location shown.



**⚠ WARNING:** Before beginning this or any exercise program, consult your physician. This is especially important for persons over the age of 35 or persons with pre-existing health problems. Read all instructions before using. ICON assumes no responsibility for personal injury or property damage sustained by or through the use of this product.

# BEFORE YOU BEGIN

Thank you for selecting the PROFORM® QUIK LOCK adjustable handweights. The adjustable handweights and dumbbell tray are designed to allow you quick adjustment and storage of your QUIK LOCK handweight set.

**For your benefit, read this manual carefully before using the adjustable handweights.** If you have additional questions, please call our Customer Service Department toll-free at 1-888-533-1333, Monday

through Friday, 6 a.m. until 6 p.m. Mountain Time (excluding holidays). To help us assist you, please note the product model number and serial number before calling. The model number is PFMC12330. The serial number can be found on a decal attached to the dumbbell tray (see the front cover of this manual).

Before reading further, please review the drawing below and familiarize yourself with the parts that are labeled.

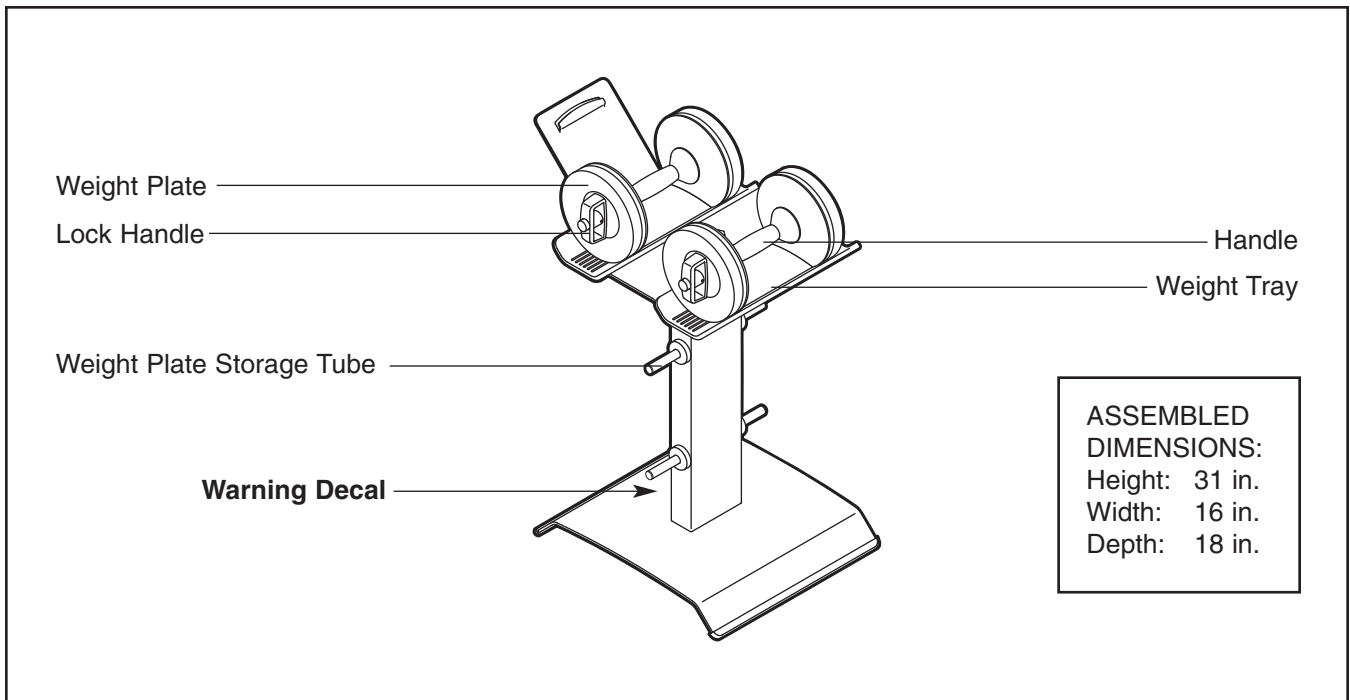

# ASSEMBLY

## Make Things Easier for Yourself

Everything in this manual is designed to ensure that the adjustable handweights can be assembled successfully by anyone. Most people find that by setting aside plenty of time, assembly will go smoothly.

**Before beginning assembly, carefully read the following information and instructions:**

- Place all parts in a cleared area and remove the packing materials. Do not dispose of the packing materials until assembly is completed.
- As you assemble the adjustable handweights, make sure all parts are oriented as shown in the drawings.

The Allen wrench  and the following tools (not included) are required for assembly:

- One rubber mallet

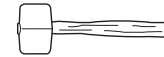

1. **Before beginning assembly, make sure that you understand the information in the box above.**

Screw two Plate Stops (12) onto each Handle (13). **Make sure that the Plate Stops are fully tightened.**

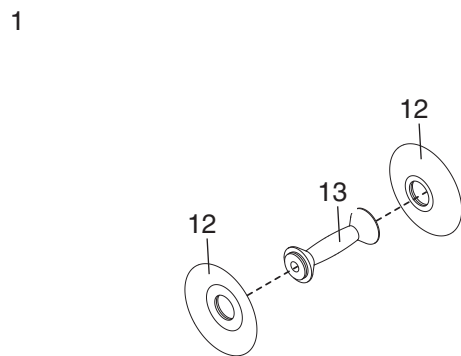

2. Press four 16mm Inner Caps (16) into the Frame (2). Slide four Bumpers (7) onto the Frame.

Attach the Frame (2) to the Base (1) with two M10 x 35mm Button Screws (14). **Make sure the storage tubes are closer to the bottom.**

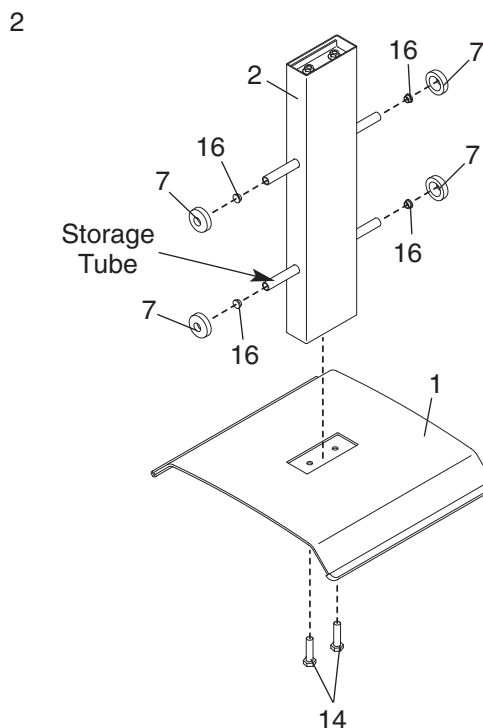

3. Attach the Tray (3) to the Frame (2) with two M10 x 35m Button Screws (14). **Make sure the indicated screw holes on the bottom of the Tray are on the same side as the warning decal.**

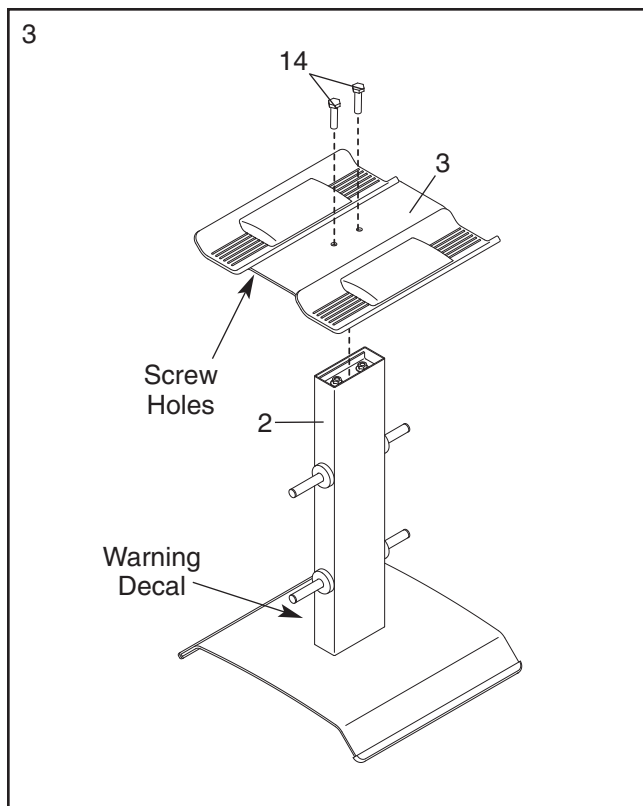

4. Attach the Clip Panel (4) to the Tray (3) with two M8 x 16mm Button Screws (15).

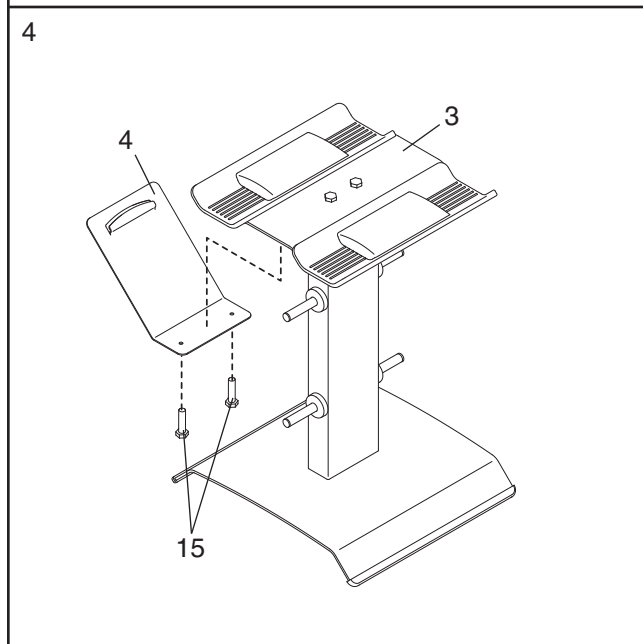

5. **Make sure that all parts are properly tightened before you use the adjustable handweights.** The use of all remaining parts will be explained in ADJUSTMENTS, beginning on the following page.

# ADJUSTMENTS

The steps below explain how the adjustable handweights can be adjusted. Make sure all parts are properly tightened each time the adjustable handweights and dumbbell tray are used. Replace any worn parts immediately. The adjustable handweights and dumbbell tray can be cleaned with a damp cloth and a mild, non-abrasive detergent. Do not use solvents.

## USING THE HANDWEIGHTS

Hold the button on the Lock Handle (8) in, and insert the Lock Handle through the desired Plates (9, 10, 11) and into the Handle (13). Release the button and turn the Lock Handle clockwise until tight.

**Attach an equal amount of weight to the other side of the Handle (13) in the same manner.**

To remove the Plates (9, 10, 11), turn the Lock Handle (8) counterclockwise and depress the button. Pull the Lock Handle out of the Handle (13).

**⚠ WARNING:** Always lift the handweights using the Handles (13). Do not lift the handweights by the Lock Handles (8).

Attach weight Plates (9, 10, 11) to a Handle (13) only while the Handle is on the Tray (3) in the position shown, or on the ground. Do not hold the Handle (13) in a vertical position when adding or removing Plates. The Plates could fall if attached in a manner other than as described here.

Make sure the weight Plates (9, 10, 11) do not fall off the Tray (3) as you are inserting or removing the Lock Handle (8).

## STORING THE PLATES

When you are not using the weight Plates (9, 10, 11), they can be stored on the storage tubes on the Frame (2).

The Handles (13) can be stored on the Tray (3) while not being used.

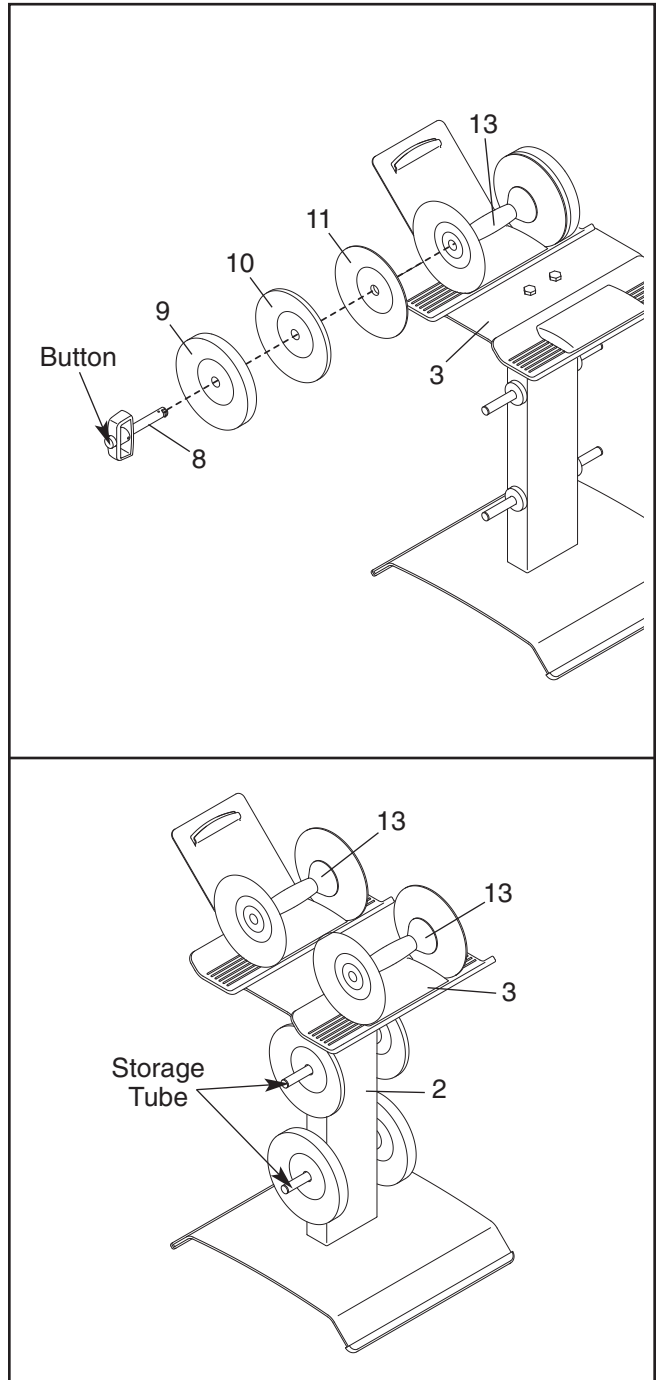

# PART LIST & EXPLODED DRAWING—Model No. PFMC12330 R0204A

Key No.	Qty.	Description	Key No.	Qty.	Description
1	1	Base	12	4	Plate Stop
2	1	Frame	13	2	Handle
3	1	Tray	14	4	M10 x 35mm Button Screw
4	1	Clip Panel	15	2	M8 x 16mm Button Screw
5	2	Tray Insert	16	4	16mm Inner Cap
6	2	Base Cap	#	1	User's Manual
7	4	Bumper	#	1	Exercise Ball
8	4	Lock Handle	#	1	Pump
9	4	10-pound Plate	#	1	Allen Wrench
10	4	5-pound Plate			
11	4	2.5-pound Plate			

Note: “#” indicates a non-illustrated part. Specifications are subject to change without notice. See the back cover of this manual for information about ordering replacement parts.

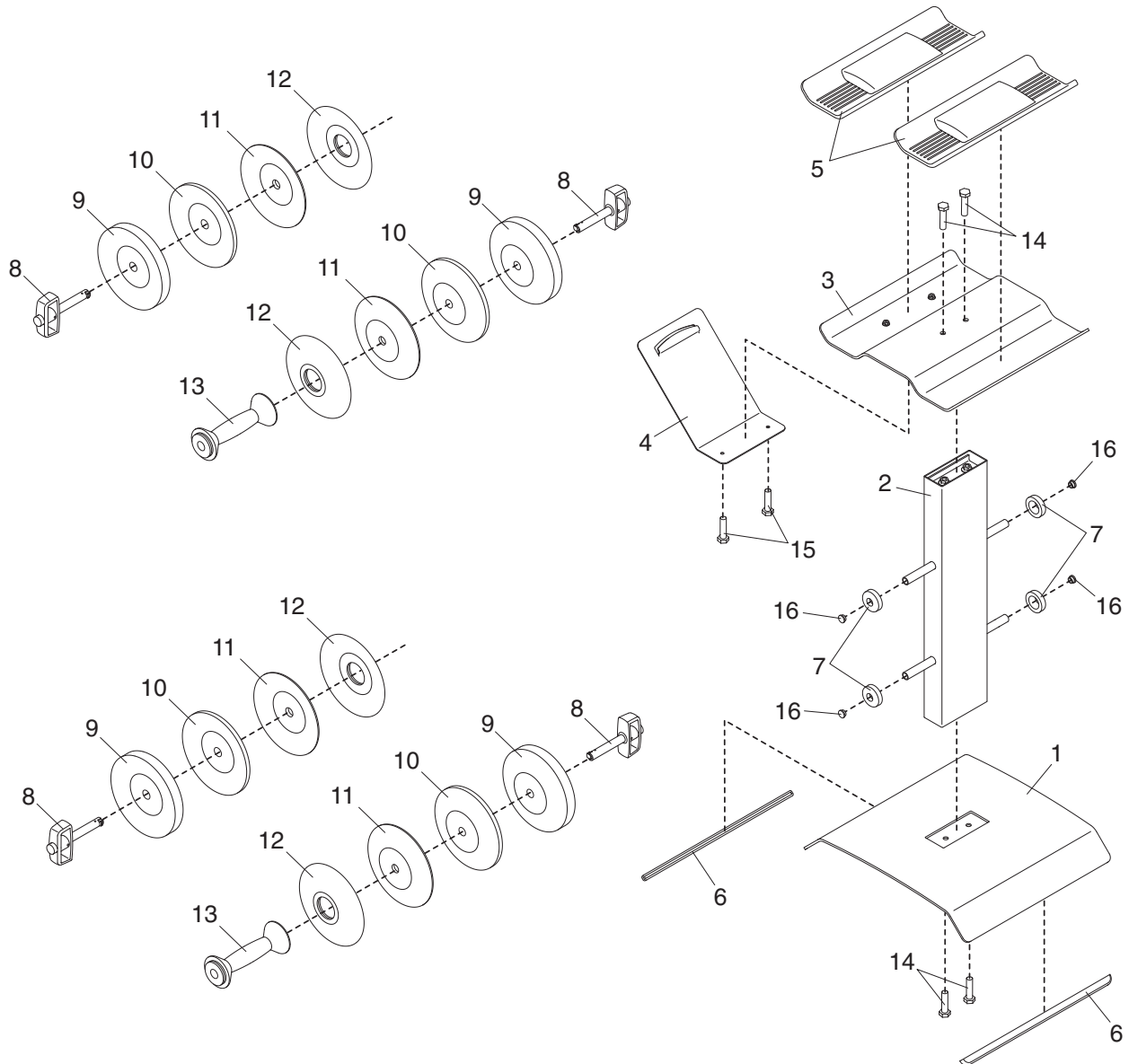

---

# ORDERING REPLACEMENT PARTS

To order replacement parts, simply call our Customer Service Department toll-free at 1-888-533-1333, Monday through Friday, 6 a.m. until 6 p.m. Mountain Time (excluding holidays). To help us assist you, please be prepared to give the following information:

1. The MODEL NUMBER of the product (PFMC12330)
2. The NAME of the product (PROFORM® QUIK LOCK adjustable handweights)
3. The SERIAL NUMBER of the product (see the front cover of this manual)
4. The KEY NUMBER and DESCRIPTION of the part(s) (see the PART LIST and EXPLODED DRAWING on page 7 of this manual)

PROFORM is a registered trademark of ICON Health & Fitness, Inc.

---

## LIMITED WARRANTY

ICON Health & Fitness, Inc. (ICON), warrants this product to be free from defects in workmanship and material, under normal use and service conditions, for a period of ninety (90) days from the date of purchase. This warranty extends only to the original purchaser. ICON's obligation under this warranty is limited to replacing or repairing, at ICON's option, the product through one of its authorized service centers. All repairs for which warranty claims are made must be pre-authorized by ICON. This warranty does not extend to any product or damage to a product caused by or attributable to freight damage, abuse, misuse, improper or abnormal usage or repairs not provided by an ICON authorized service center; products used for commercial or rental purposes; or products used as store display models. No other warranty beyond that specifically set forth above is authorized by ICON.

ICON is not responsible or liable for indirect, special or consequential damages arising out of or in connection with the use or performance of the product or damages with respect to any economic loss, loss of property, loss of revenues or profits, loss of enjoyment or use, costs of removal or installation or other consequential damages of whatsoever nature. Some states do not allow the exclusion or limitation of incidental or consequential damages. Accordingly, the above limitation may not apply to you.

The warranty extended hereunder is in lieu of any and all other warranties and any implied warranties of merchantability or fitness for a particular purpose is limited in its scope and duration to the terms set forth herein. Some states do not allow limitations on how long an implied warranty lasts. Accordingly, the above limitation may not apply to you.

This warranty gives you specific legal rights. You may also have other rights which vary from state to state.

**ICON HEALTH & FITNESS, INC., 1500 S. 1000 W., LOGAN, UT 84321-9813**