



MANUAL INSERT

Model G1033Z

20" 5 HP Planer

INTRODUCTION

The Model G1033Z is the same planer as the Model G1033 with the upgrade of the chromed 3-roller extension rollers and 5 HP motor.

INVENTORY

- 1. Planer Unit..... 1
- 2. Dust Hood 1
- 3. Starter Switch Assembly 1
- 4. Table Extension Roller Assembly 2
- 5. Handwheel 1
- 6. Handwheel Handle 1
- 6. Hardware Bag :
 - Hex Bolt M6-1 x 12..... 6
 - Flat Washer 6mm 6
 - Hex Bolt M10-1.5 x 25..... 8
 - Flat Washer 1/2" 8
 - Knife Setting Rod..... 1
 - Knife Setting Gauge 2
 - E-Clip Ring 9mm..... 4
 - Hex Nut M12-1.75 1
 - Flat Washer 12mm 1
 - Direction Label..... 1
 - Allen Wrench 3mm 1
 - Allen Wrench 4mm 1
 - Allen Wrench 5mm 1
 - Allen Wrench 6mm 1
 - Open End Wrench 8/10mm..... 1
 - Open End Wrench 12/14mm..... 1
 - Open End Wrench 17/19mm..... 1

RECOMMENDED FOR SETUP

G1738—Rotacator™ Precision Planer Tool

The Rotacator is a dial indicator on a magnetic base designed for quickly and accurately setting the critical tolerances needed when adjusting planers to avoid chattered cuts.

Helps adjust infeed/outfeed rollers, pressure bars, chip breakers, and bed rollers. Also a great setup tool for other machines! Accurate to 0.001". Indicator rotates 360°.

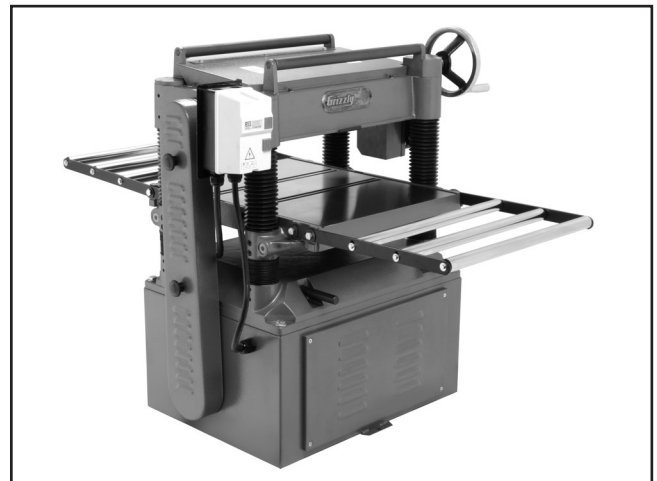

Figure 1. Model G1033Z.



Figure 2. Rotacator™ Precision Planer Tool is an important tool for setting up your planer for the highest quality results.

Call 1-800-523-4777 To Order

G1033Z Replacement Parts

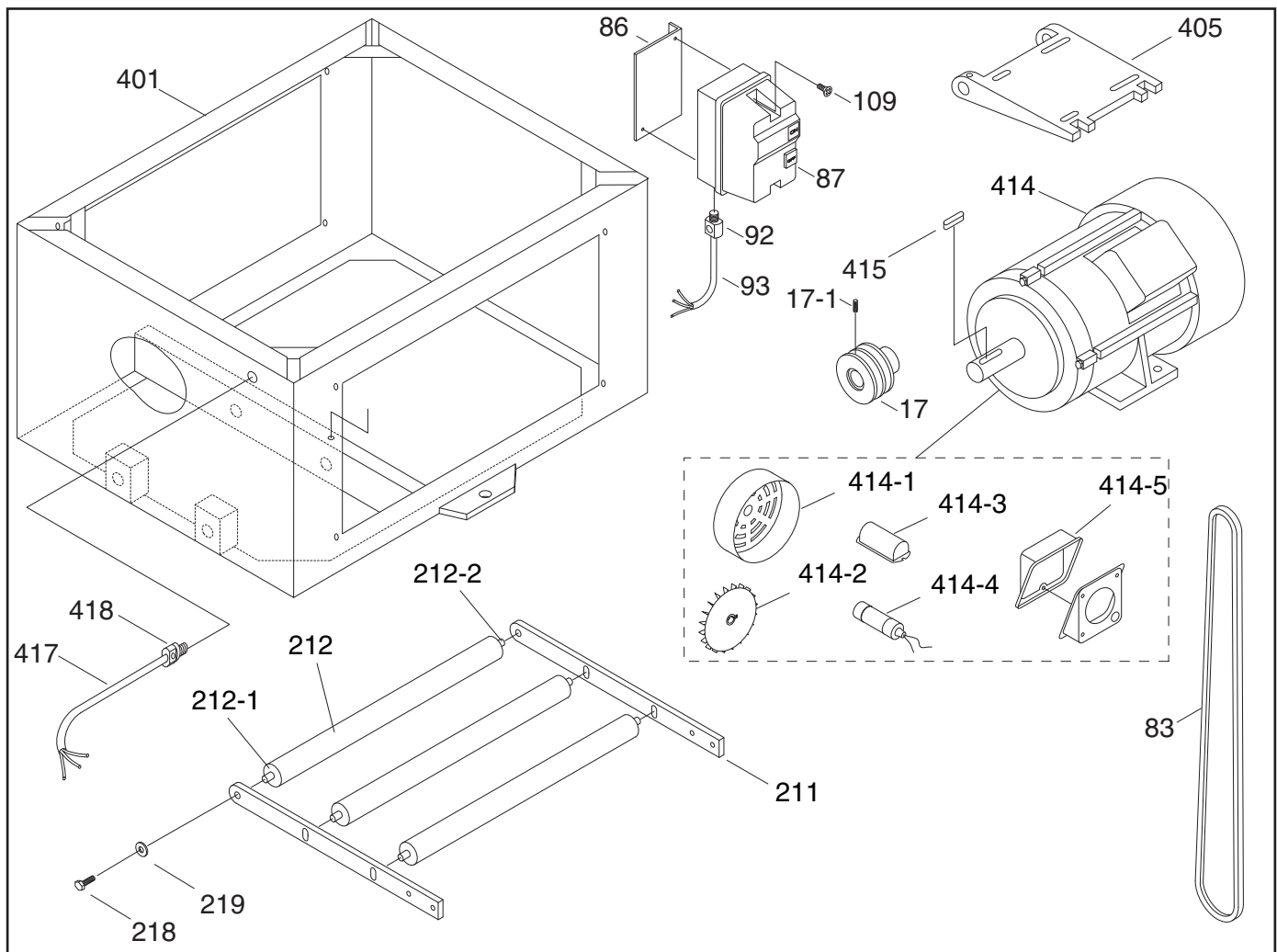

REF	PART #	DESCRIPTION	REF	PART #	DESCRIPTION
17	P1033Z017	MOTOR PULLEY	219	PW01M	FLAT WASHER 8MM
17-1	PSS04M	SET SCREW M6-1 X 12	401	P1033Z401	CABINET STAND
83	PVM58	V-BELT M-58 3L580	405	P1033Z405	MOTOR MOUNT
86	P1033Z086	SWITCH BRACKET	414	P1033Z414	5 HP MOTOR
87	P1033Z087	MAGNETIC SWITCH MA-30	414-1	P1033Z414-1	MOTOR FAN COVER
92	P1033Z092	STRAIN RELIEF MG25A	414-2	P1033Z414-2	MOTOR FAN
93	P1033Z093	MOTOR CORD 10AWG X 3C	414-3	P1033Z414-3	CAPACITOR COVER
109	P1033Z109	PLASTIC SWITCH CVR SCREW	414-4	P1033Z414-4	S CAP. 800M 250V 1-3/8 X 3-3/4
211	P1033211	3 HOLE ROLLER BRACKET	414-5	P1033Z414-5	JUNCTION BOX
212	P1033212	CHROME ROLLER	415	P1033Z415	KEY 8 X 7 X 55
212-1	P1033Z212-1	PLASTIC BUSHING	417	P1033Z417	POWER CORD 10AWG X 3C
212-2	P1033Z212-2	ROLLER ROD	418	P1033Z092	STRAIN RELIEF MG25A
218	PB02M	HEX BOLT M6-1 X 12			

COPYRIGHT © MARCH, 2005. BY GRIZZLY INDUSTRIAL, INC.
WARNING: NO PORTION OF THIS MANUAL MAY BE REPRODUCED IN ANY SHAPE OR FORM WITHOUT THE WRITTEN APPROVAL OF GRIZZLY INDUSTRIAL, INC.
 #TR7023 PRINTED IN TAIWAN

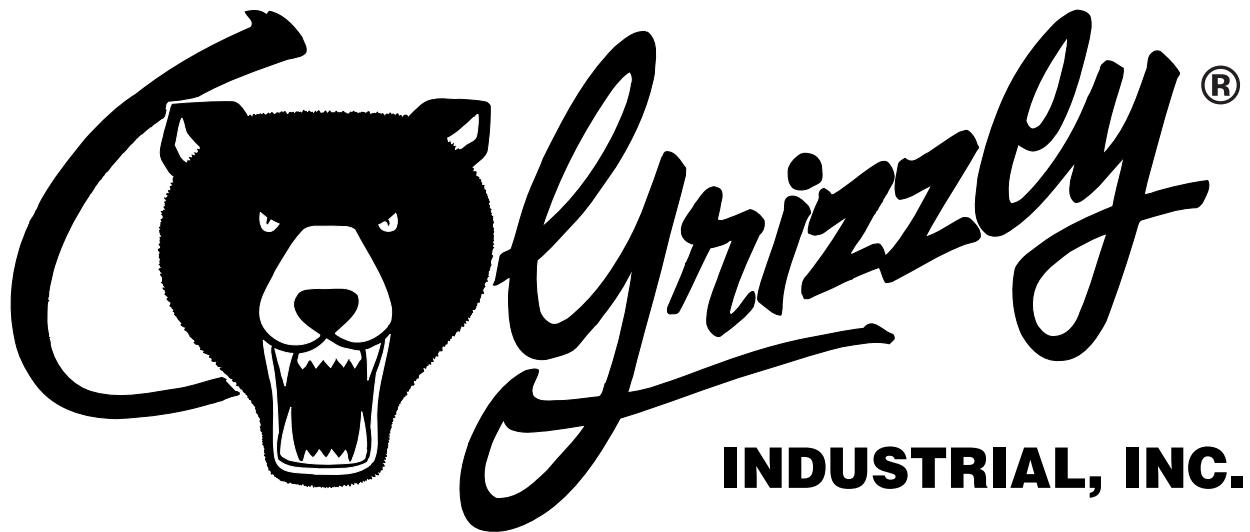

20" PLANER
MODEL G1033
INSTRUCTION MANUAL



COPYRIGHT © 1990 BY GRIZZLY INDUSTRIAL, INC.
WARNING: NO PORTION OF THIS MANUAL MAY BE REPRODUCED IN ANY SHAPE
OR FORM WITHOUT THE WRITTEN APPROVAL OF GRIZZLY INDUSTRIAL, INC.
REVISED APRIL, 1999. PRINTED IN U.S.A.



WARNING!

Some dust created by power sanding, sawing, grinding, drilling, and other construction activities contains chemicals known to the State of California to cause cancer, birth defects or other reproductive harm. Some examples of these chemical are:

- **Lead from lead-based paints.**
- **Crystalline silica from bricks, cement and other masonry products.**
- **Arsenic and chromium from chemically-treated lumber.**

Your risk from these exposures varies, depending on how often you do this type of work. To reduce your exposure to these chemicals: Work in a well ventilated area, and work with approved safety equipment, such as those dust masks that are specially designed to filter out microscopic particles.

Table Of Contents

	PAGE
1. SAFETY	
SAFETY RULES FOR POWER TOOLS	2-3
ADDITIONAL SAFETY INSTRUCTIONS FOR PLANERS	4
2. CIRCUIT REQUIREMENTS	
220V OPERATION	5
FUSING	5
GROUNDING.....	5
EXTENSION CORDS	5
3. INTRODUCTION	
COMMENTARY	6
UNPACKING	7
PARTS INVENTORY	7
CLEAN UP	8
SITE CONSIDERATIONS	8
4. ASSEMBLY	
OVERVIEW	9
EXTENSION ROLLERS	9
HANDWHEEL	9
DUST HOOD	10
SWITCH.....	10
KNIFE SETTING JIG	11
5. ADJUSTMENTS	
CHAIN ADJUSTMENT.....	12
TABLE ADJUSTMENT	12
CHAIN DRIVE	13
BED ROLLERS	14
KNIFE INSPECTION	15
KNIFE ADJUSTMENT	15
FEED ROLLER SPEED.....	16
ROLLER ADJUSTMENT	16-17
SPRING TENSION	17
CHIP BREAKER	18
PRESSURE BAR.....	18
CHIP DEFLECTOR	19
STATIC CHAIN ADJUSTER	19
SCALE ADJUSTMENT	20
ANTI-KICKBACK FINGERS	20
6. OPERATIONS	
TEST RUN.....	21
OPERATIONAL TIPS	21
WOOD CHARACTERISTICS	22
7. MAINTENANCE	
GENERAL	23
KNIVES	23
LUBRICATION.....	24
BELT TENSION.....	25
BELT ALIGNMENT	25
8. CLOSURE	
MACHINE DATA	27
TROUBLESHOOTING.....	28
PARTS BREAKDOWN AND PARTS LISTS	29-35
ADJUSTMENT BLOCK PATTERN	36
WIRING DIAGRAM	37
WARRANTY AND RETURNS	38

SECTION 1: SAFETY

WARNING

For Your Own Safety Read Instruction Manual Before Operating This Equipment

The purpose of safety symbols is to attract your attention to possible hazardous conditions. This manual uses a series of symbols and signal words which are intended to convey the level of importance of the safety messages. The progression of symbols is described below. Remember that safety messages by themselves do not eliminate danger and are not a substitute for proper accident prevention measures.

 **DANGER** Indicates an imminently hazardous situation which, if not avoided, WILL result in death or serious injury.

 **WARNING** Indicates a potentially hazardous situation which, if not avoided, COULD result in death or serious injury.

 **CAUTION** Indicates a potentially hazardous situation which, if not avoided, MAY result in minor or moderate injury. It may also be used to alert against unsafe practices.

NOTICE This symbol is used to alert the user to useful information about proper operation of the equipment.

WARNING

Safety Instructions For Power Tools

1. **KEEP GUARDS IN PLACE** and in working order.
2. **REMOVE ADJUSTING KEYS AND WRENCHES.** Form habit of checking to see that keys and adjusting wrenches are removed from tool before turning on.
3. **KEEP WORK AREA CLEAN.** Cluttered areas and benches invite accidents.
4. **DON'T USE IN DANGEROUS ENVIRONMENT.** Don't use power tools in damp or wet locations, or where any flammable or noxious fumes may exist. Keep work area well lighted.
5. **KEEP CHILDREN AND VISITORS AWAY.** All children and visitors should be kept a safe distance from work area.
6. **MAKE WORK SHOP CHILD PROOF** with padlocks, master switches, or by removing starter keys.
7. **DON'T FORCE TOOL.** It will do the job better and safer at the rate for which it was designed.
8. **USE RIGHT TOOL.** Don't force tool or attachment to do a job for which it was not designed.

WARNING

Safety Instructions For Power Tools

9. USE PROPER EXTENSION CORD. Make sure your extension cord is in good condition. Conductor size should be in accordance with the chart below. The amperage rating should be listed on the motor or tool nameplate. An undersized cord will cause a drop in line voltage resulting in loss of power and overheating. Your extension cord must also contain a ground wire and plug pin. Always repair or replace extension cords if they become damaged.

Minimum Gauge for Extension Cords

AMP RATING	LENGTH		
	25ft	50ft	100ft
0-6	18	16	16
7-10	18	16	14
11-12	16	16	14
13-16	14	12	12
17-20	12	12	10
21-30	10	10	No

10. WEAR PROPER APPAREL. Do not wear loose clothing, gloves, neckties, rings, bracelets, or other jewelry which may get caught in moving parts. Non-slip footwear is recommended. Wear protective hair covering to contain long hair.

11. ALWAYS USE SAFETY GLASSES. Also use face or dust mask if cutting operation is dusty. Everyday eyeglasses only have impact resistant lenses, they are NOT safety glasses.

12. SECURE WORK. Use clamps or a vise to hold work when practical. It's safer than using your hand and frees both hands to operate tool.

13. DON'T OVERREACH. Keep proper footing and balance at all times.

14. MAINTAIN TOOLS WITH CARE. Keep tools sharp and clean for best and safest performance. Follow instructions for lubricating and changing accessories.

15. DISCONNECT TOOLS before servicing and changing accessories, such as blades, bits, cutters, and the like.

16. REDUCE THE RISK OF UNINTENTIONAL STARTING. Make sure switch is in off position before plugging in.

17. USE RECOMMENDED ACCESSORIES. Consult the owner's manual for recommended accessories. The use of improper accessories may cause risk of injury.

18. CHECK DAMAGED PARTS. Before further use of the tool, a guard or other part that is damaged should be carefully checked to determine that it will operate properly and perform its intended function. Check for alignment of moving parts, binding of moving parts, breakage of parts, mounting, and any other conditions that may affect its operation. A guard or other part that is damaged should be properly repaired or replaced.

19. NEVER LEAVE TOOL RUNNING UNATTENDED. TURN POWER OFF. Don't leave tool until it comes to a complete stop.

WARNING

Additional Safety Instructions For Planers

1. Ensure that the machine sits firmly on the floor before use. Any “wobbles” must be corrected by shimming or blocking before operation.
2. This machine is not designed to process any other material except wood.
3. Never position fingers or thumbs near the infeed roller.
4. Long stock should always be fully supported by some type of support fixture.
5. Do not operate planer with dull or damaged knives.
6. Ensure that the planer is properly adjusted before using.
7. Do not remove excessive amounts of wood in a single pass.
8. Inspect your stock before planing. Reject stock with defects and foreign material
9. Do not attempt to remove jams until power is disconnected and all moving parts have come to a complete stop.
10. Provide adequate infeed and outfeed space for operating the planer.
11. Do not plane wood less than 12" long and ¼" thick.
12. Do not plane lumber with loose knots or knots that may become loose during planing.

WARNING

Like all power tools, there is danger associated with the Model G1033 20" Planer. Accidents are frequently caused by lack of familiarity or failure to pay attention. Use this tool with respect and caution to lessen the possibility of operator injury. If normal safety precautions are overlooked or ignored serious personal injury may occur.

WARNING

Operating this equipment has the potential to propel debris into the air which can cause eye injury. Always wear safety glasses or goggles when operating equipment. Everyday glasses or reading glasses only have impact resistant lenses, they are not safety glasses. Be certain the safety glasses you wear meet the appropriate standards of the American National Standards Institute (ANSI).

CAUTION

No list of safety guidelines can be complete. Every shop environment is different. Always consider safety first, as it applies to your individual working conditions. Use this and other machinery with caution and respect. Failure to do so could result in serious personal injury, damage to equipment or poor work results.

SECTION 2: CIRCUIT REQUIREMENTS

220V Operation

The 3 HP G1033 Planer motor is wired to operate at 220V only. A 220V plug that matches your 220V receptacle must attach to the end of the power cord. Plugs and receptacles can be purchased at your local hardware store or home center. When connecting to 220V, ensure that the electrical circuit is in fact a 220V circuit. Contact your local electrical contractor if uncertain about converting to 220V operation. A wiring diagram for the motor and switch is provided at the back of this manual should more detail be needed.

When operating at 220V, we recommend using a NEMA-style 6-30 plug and outlet. **See Figure 1.** You may also “hard-wire” the planer directly to your panel, provided you place a disconnect switch near the machine.

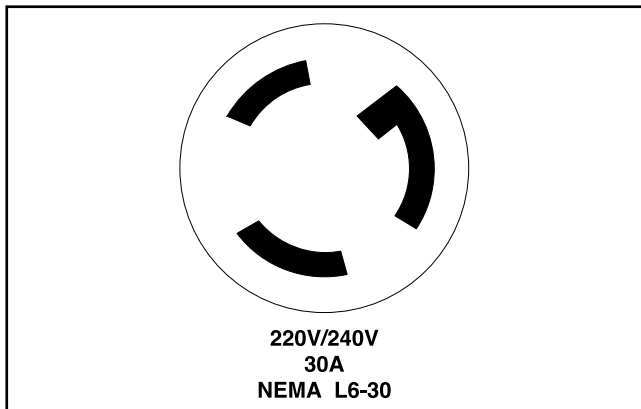

Figure 1. Twist-lock style 30A connector.

Fusing

The Model G1033 should be fused at 30 amps. Fusing at amperage ratings higher than 30 amps will not adequately protect the motor. You are cautioned that equipment that is returned to us for service that shows evidence of being overfused will be repaired or replaced totally at the customer's expense, regardless of the present warranty status.



Grounding

In the event of an electrical short, grounding reduces the risk of electric shock by providing a path of least resistance to disperse electric current. This tool is equipped with a power cord having an equipment-grounding conductor. The outlet must be properly installed and grounded in accordance with all local codes and ordinances.

⚠️ WARNING

This equipment must be grounded. Please ensure that this machine is continuously grounded from the motor to the machine frame and then to a known ground. Verify that any existing electrical outlet and circuit you intend to plug into is actually grounded. If it is not, it will be necessary to run a separate 12 A.W.G. copper grounding wire from the outlet to a known ground. Under no circumstances should the grounding pin from any three-pronged plug be removed. **Serious injury may occur.**



Extension Cords

We do not recommend the use of extension cords on 220V equipment. It is much better to arrange the placement of your equipment and the installed wiring to eliminate the need for extension cords. Should it be necessary to use an extension make sure the cord is rated Hard Service (grade S) or better. Refer to the chart in Section 1: Safety Instructions to determine the minimum gauge for the extension cord. The extension cord must also contain a ground wire and plug pin. Always repair or replace extension cords when they become worn or damaged.



SECTION 3: INTRODUCTION

Commentary

We are proud to offer the Grizzly Model G1033 20" Planer. The Model G1033 is part of a growing Grizzly family of fine woodworking machinery. When used according to the guidelines set forth in this manual, you can expect years of trouble-free, enjoyable operation and proof of Grizzly's commitment to customer satisfaction.

The Model G1033 is designed for heavy-duty professional use. It features a powerful 3HP, 220V/240V single-phase motor, four-knife cutterhead, 2-speed automatic feed, precision-ground table and a both a chipbreaker and a pressure bar to support the stock as it moves through the machine.

A number of optional accessories for the Model G1033 are available through the Grizzly catalog. They include a heavy-duty mobile base, roller stands, replacement knives and Planer Pal® planer jigs, which are invaluable when setting up or adjusting your planer's cutting knives.

We are also pleased to provide this manual with the Model G1033. It was written to guide you through assembly, review safety considerations, and cover general operating procedures. It represents our effort to produce the best documentation possible. If you have any comments regarding this manual, please write to us at the address below:

Grizzly Industrial, Inc.
% Technical Documentation
P.O. Box 2069
Bellingham, WA 98227-2069

Most importantly, we stand behind our machines. If you have any service questions or parts requests, please call or write us at the location listed below.

Grizzly Industrial, Inc.
1203 Lycoming Mall Circle
Muncy, PA 17756
Phone: (570) 546-9663
Fax: (800) 438-5901
E-Mail: techsupport@grizzly.com
Web Site: <http://www.grizzly.com>

The specifications, drawings, and photographs illustrated in this manual represent the Model G1033 as supplied when the manual was prepared. However, owing to Grizzly's policy of continuous improvement, changes may be made at any time with no obligation on the part of Grizzly. Whenever possible, though, we send manual updates to all owners of a particular tool or machine. Should you receive one, we urge you to insert the new information with the old and keep it for reference.

CAUTION

To operate this, or any power tool, safely and efficiently, it is essential to become as familiar with its characteristics as possible. The time you invest before you begin to use your Model G1033 will be time well spent. DO NOT operate this machine until you are completely familiar with the contents of this manual. Make sure you read and understand all of the safety procedures. If you do not understand something, DO NOT operate the machine.



Unpacking

This planer is shipped from the factory in a carefully packed carton. If you find the machine to be damaged after you've signed for delivery and the truck and driver are already gone, you will need to file a freight claim with the carrier. Save the containers and all packing materials for inspection by the carrier or their agent. Without the packing materials, filing a freight claim can be difficult. If you need advice regarding this situation, please call us immediately.

WARNING

The Model G1033 is a heavy machine (770 lbs. shipping weight). DO NOT over-exert yourself while unpacking or moving your machine – get assistance. In the event that your planer must be moved up or down a flight of stairs, be sure that the stairs are capable of supporting the combined weight of people and the machine. Failure to use care while assembling or moving could result in serious personal injury.



Parts Inventory

Take a quick inventory of the parts and put them aside for assembly later. After all the parts have been removed from the container, you should have:

- Planer Unit
- Dust Hood
- Hand Wheel
- Starter Switch
- Rollers (2)
- Knife Gauge
- Bolt Bag
 - (2) 12mm Snap Rings
 - (2) 10mm Flat Washers
 - (8) M10x1.5 Hex Bolts
 - (8) 6mm Flat Washers
 - (4) Snap Rings
 - (6) M10x1.5 Hex Bolts
 - (6) Flat Washers

In the event that any non-proprietary parts are missing (e.g. a nut or a washer), we would be glad to replace them, or, for the sake of expediency, replacements can be obtained at your local hardware store.

NOTICE

A full parts list and breakdown can be found toward the end of this manual. For easier assembly, or to identify missing parts, please refer to the detailed illustrations at the end of the manual.



Clean Up

The unpainted surfaces are coated with a waxy oil to protect it from corrosion during shipment. Remove this protective coating with a solvent cleaner or citrus-based degreaser. Avoid chlorine-based solvents as they may damage painted surfaces should they come in contact. Always follow the usage instructions on the product you choose for clean up.

CAUTION

Many of the solvents commonly used to clean machinery can be highly flammable, and toxic when inhaled or ingested. Always work in well-ventilated areas far from potential ignition sources when dealing with solvents. Use care when disposing of waste rags and towels to be sure they do not create fire or environmental hazards. Keep children and animals safely away when cleaning and assembling this machine.

WARNING

Do not use gasoline or other petroleum-based solvents to remove this protective coating. These products generally have low flash points which makes them extremely flammable. A risk of explosion and burning exists if these products are used. Serious personal injury may occur.

CAUTION

Some die-cut metal parts may have sharp edges (called “flashing”) on them after they are formed. Please examine the edges of all die-cut metal parts before handling them. Failure to do so could result in injury.



Site Considerations

FLOOR LOAD

Your G1033 Planer represents a large weight load in a small footprint. Most commercial floors are suitable for the Model G1033. Some residential floors may require additional build up to support both machine and operator.

WORKING CLEARANCES

Working clearances can be thought of as the distances between machines and obstacles that allow safe operation of every machine without limitation. Consider existing and anticipated machine needs, size of material to be processed through each machine, and space for auxiliary stands and/or work tables. Also consider the relative position of each machine to one another for efficient material handling. Be sure to allow yourself sufficient room to safely run your machines in any foreseeable operation.

LIGHTING AND OUTLETS

Lighting should be bright enough to eliminate shadow and prevent eye strain. Electrical circuits should be dedicated or large enough to handle combined motor amp loads. Outlets should be located near each machine so power or extension cords are not obstructing high-traffic areas. Be sure to observe local electrical codes for proper installation of new lighting, outlets, or circuits.

CAUTION

Make your shop “child safe”. Ensure that your workplace is inaccessible to youngsters by closing and locking all entrances when you are away. Never allow visitors in your shop when assembling, adjusting or operating equipment.



SECTION 4: ASSEMBLY

Overview

Most of your G1033 Planer has been assembled at the factory, but some parts must be assembled or installed after delivery. We have organized the assembly process into steps. Please follow along in the order presented here.

TOOLS REQUIRED: Most of the tools required for assembly are included with the planer. However, you will also need a Phillips® and regular screwdriver, metric wrenches, as well as a feeler gauge for adjustments.

Extension Rollers

The Model G1033 is supplied with extension rollers on both the infeed and outfeed ends of the table. The roller assemblies are identical for both infeed and outfeed. To attach the extension rollers:

1. Attach an extension bar to the end of each roller and secure with the 12mm snap rings provided.
2. The assembled extension rollers attach to the ends of the planer's table. Match the tapped holes on the side of the table to the extension bars and attach with the M10 x 1.5 Hex Bolts and washers provided. **See Figure 2.**
3. Before final tightening, run a straight edge across the table and past each roller. Position the rollers flush with the table and tighten the Hex Bolts securely.

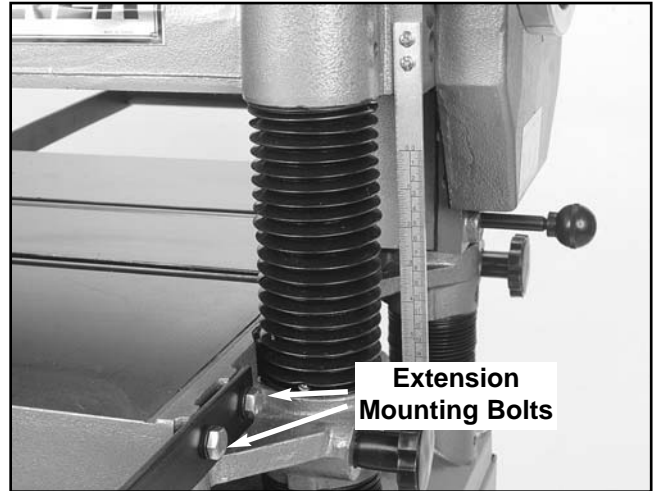

Figure 2. Extension roller attachment.



Hand Wheel

The hand wheel operates the chain driven system which raises and lowers the table to control cutting depth. To attach the hand wheel:

1. Place the handwheel on the worm gear shaft and secure with hex nut and washer provided. **See Figure 3.**
2. Attach the handle to the handwheel and tighten hex nut.



Figure 3. Attaching handwheel.



Dust Hood

The G1033 features a dust hood with a 5" dust port. It is only to be used in conjunction with a dust collection system. Install the dust hood as follows:

1. Match the mounting holes on the dust hood with the tapped holes on the outfeed end of the cutterhead casting.
2. Using the six M6-1.0 Hex bolts provided, secure the dust hood to the cutterhead casting. **See Figure 4.**

See note regarding the use of a dust collector and chip deflector adjustment in the adjustment section of this manual.

CAUTION

DO NOT attach the dust hood if you do not intend to connect the Model G1033 to a dust collection system. Accumulated wood chips could cause a malfunction, resulting in personal injury or damage to the planer.

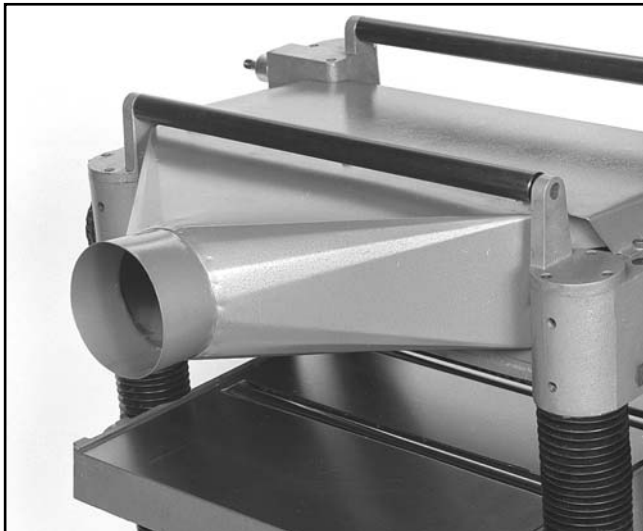

Figure 4. Dust hood in place.



Switch

The magnetic ON/OFF switch supplied with the Planer is pre-wired to the motor. The remaining step requires connecting the switch to the planer's head casting. To attach the switch:

1. Align the holes on the flanges at the back of the switch box with the tapped holes on the front left corner of the head casting.
2. Using the socket head cap screws provided, attach the switch box assembly to the head casting. **See Figure 5.**

The G1033 is shipped without a plug. Now would be a good time to attach the appropriate plug specified in Section 2: Circuit Requirements.

WARNING

Do not attempt to make any adjustments to this machine or perform routine maintenance without unplugging it from its power source. Serious injury could result.

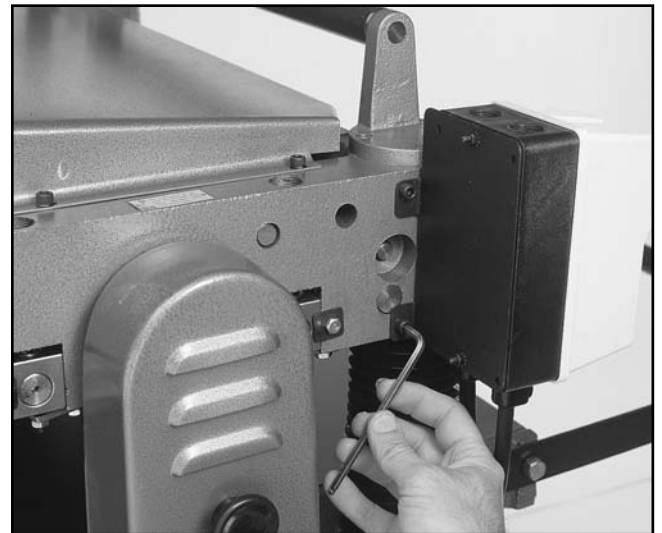

Figure 5. Attaching switch.



Knife Setting Jig

The knife setting jig has been provided to make knife setting quick and easy. See **Figure 6**.

To assemble the knife setting jig:

1. Snap one of the E-clips over the notch on one end of the knife setting rod.
2. Slide the cast aluminum knife setting jig brackets onto the rod.
3. Snap the other E-clip onto the notch at the other end of the knife setting rod.

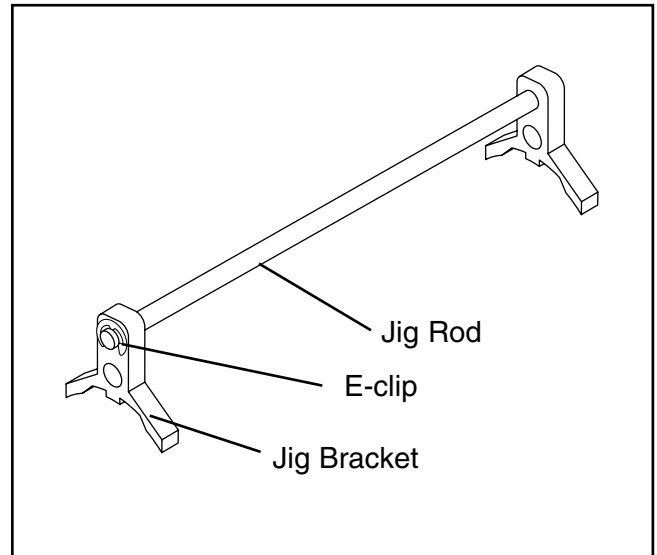

Figure 6. Knife setting jig.

⚠ CAUTION

Planer knives are dangerously sharp. Use extreme caution when working near cutting surfaces. Failure to exercise care while working near knives could result in severe injury.

NOTES

SECTION 5: ADJUSTMENTS

Chain Adjustment

The chain drive in the Model G1033 transfers movement from the hand wheel driven column to the three other support columns. The chain drive may require adjustment to remove slack as the chain stretches over time, or as part of table leveling procedures. To adjust the chain:

1. Remove the two access panels on the stand.
2. Loosen the two locking bolts and move the idler sprocket until chain play has been eliminated. **See Figure 7.**
3. Re-tighten the two locking bolts.
4. Check chain lubrication. Refer to the **Maintenance Section** for further details.

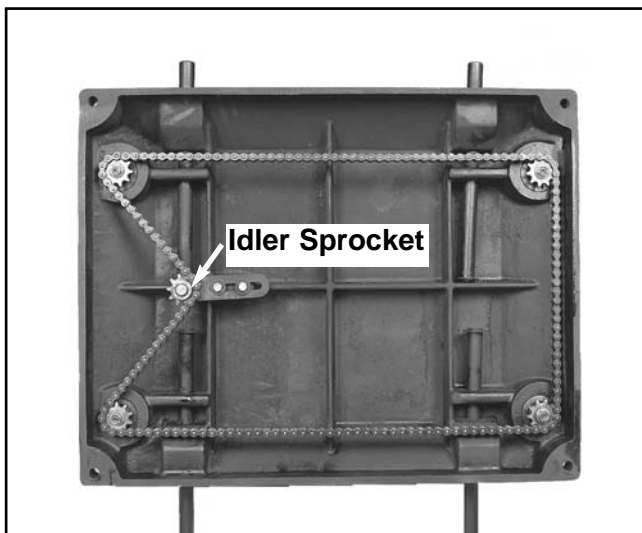

Figure 7. Idler sprocket adjustment.



Table Adjustment

The Model G1033's table movement is critical to the operation of the machine. As such, it is essential that the table is aligned correctly with the cutterhead and the head casting. For the power feed to work correctly, it is important that the table be the same distance from the head casting in front and back. To make table adjustments, it will be necessary to construct the measurement block "A". See page 36 for a full size print of block "A". To adjust the front-to-back distances:

1. Place Block "A" on the front right corner of the table and raise the table until the top of the block comes in contact with the bottom of the head casting.
2. Without moving the table position, move the block to the rear right corner under the head casting. If the block will not fit under the head casting, or if the gap between the head casting and the table exceeds .016" (use a feeler gauge to determine gap) you will need to adjust the chain drive. **See Figure 8.**



Figure 8. Measurement block in place.



Chain Drive

Adjust the chain drive by loosening the chain tensioner and loosen the chain until you can turn each corner sprocket independently. If the back of the table is too high, the back two sprockets will need to be rotated clockwise to lower the table. Each tooth on the sprocket represents .016" of vertical movement as the cogs are turned. Make sure, as you turn the sprocket, to keep an accurate tooth count to ensure that the table is lowered equally on both the left and right sides. Turn the sprockets in small increments until the front clearance matches the back.

When the front-to-back clearance is within the .016" tolerance, tighten the idler sprocket on the chain drive and tighten the lock bolts.

With the front-to-back adjustments made, we can concentrate on the alignment between the table and cutterhead. To check table-to-cutterhead alignment:

1. Place Block "A" on the table under the left end of the cutterhead. Raise the table until the block touches the bottom of the cutterhead. **See Figure 9.**
2. Slide the block across the table toward the right side of the cutterhead.
3. If the block becomes too tightly wedged between the table and the cutterhead, or if there is a noticeable gap between the block and the cutterhead, the table will need to be adjusted.
4. If you find a substantial gap (larger than .016"), follow the directions above for loosening the chain drive and turn the two right sprockets (independently of the chain) until the gap is eliminated. Turn the sprockets counterclockwise from the bottom to raise the table.
5. If the table is too high at the right side, rotate the sprockets in the opposite direction.

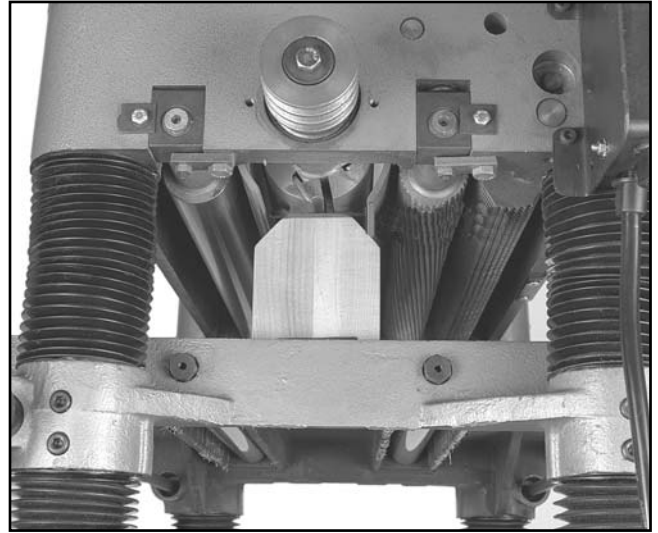

Figure 9. Using block to align cutterhead.

When you get the tolerance to within the .016" range, micro-adjust by loosening the Allen head cap screws and lifting the table upward or downward until the table and cutterhead are in alignment. **See Figure 10.** This process may require adjusting the columns on both the left and right hand sides until you find the correct combination.

REMEMBER: When making adjustments, be certain to tighten fasteners after each step to ensure the accuracy of your tests. When adjusting the chain drive, keep in mind that if the chain becomes too loose, it will fall off of all the sprockets. Returning it to its proper location can be frustrating.

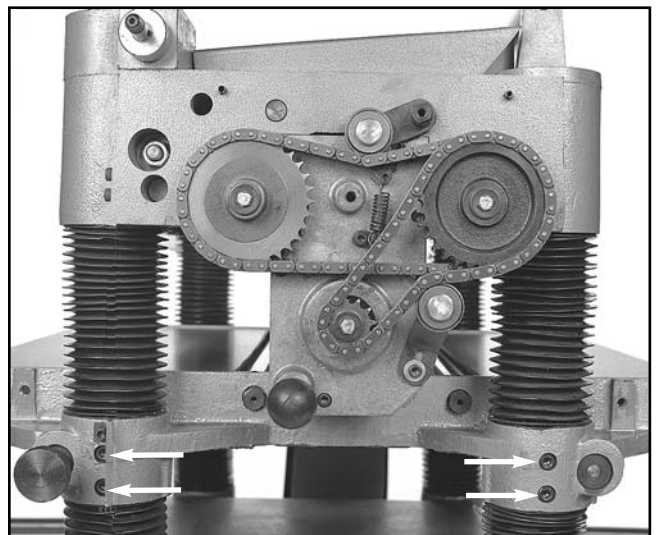

Figure 10. Micro-adjustment screws.



Bed Rollers

After completing adjustments to the table, align the bed rollers. The height of the bed rollers will vary, depending on the type of material you intend to plane. When planing rough stock, you will need to set the rollers high to keep the lumber from dragging along the bed. Milled lumber should be planed with the rollers set lower. To adjust the rollers correctly:

1. Lay a good quality straightedge across both bed rollers, using a machinist's square to keep the straightedge perpendicular to the table.
2. Using a feeler gauge, measure the distance between the straightedge and the table. The tolerance between the table and the straightedge should be the same across the table. The ideal tolerance should be between 0" and .015", the larger measurement for rougher stock. **See Figure 11.** Be careful using the larger tolerance. Anytime the rollers are higher than the table the potential exists for snipe, or gouging near the end of the board

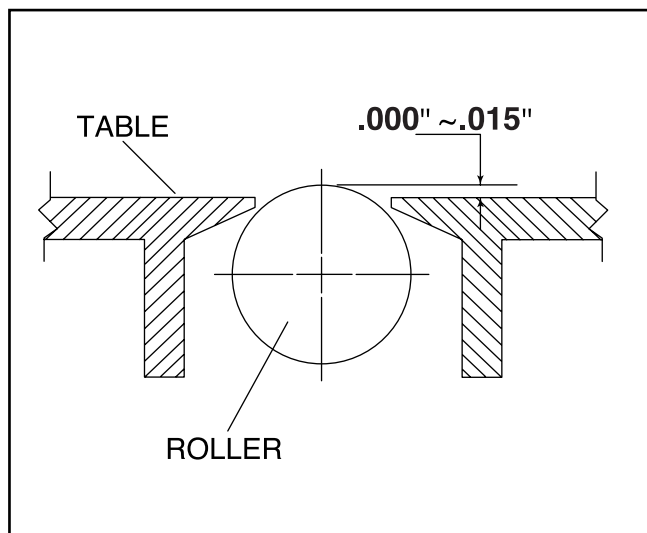

Figure 11. Bed roller tolerances.

3. To adjust the rollers, loosen the setscrews at the left end of the rollers and, using an Allen® wrench, raise or lower the rollers on their eccentric shafts to reach your desired height across the table. **See Figure 12.**

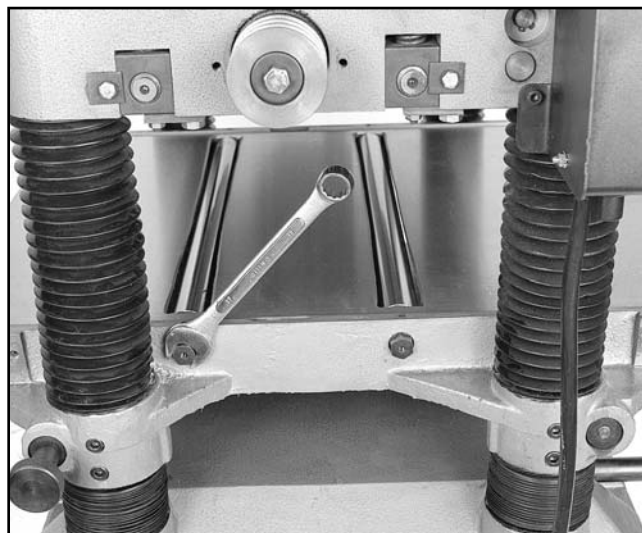

Figure 12. Roller height adjustment.

4. Once your roller heights are corrected, re-tighten the setscrews.
5. Spin the rollers and inspect for free movement.

⚠ CAUTION

Planer knives are dangerously sharp. Use extreme caution when working near cutting surfaces. Failure to exercise care while working near knives could result in severe injury.



Knife Inspection

The G1033 20" Planer comes equipped with a 4-knife cutterhead. The knives must be periodically replaced or adjusted. Adjustments should be as precise as possible with tolerances within $\pm.001$ " to prolong the sharpness of the knife edges. Improperly adjusted knives can unbalance the cutterhead and shorten bearing life, as well as produce substandard planing results. The knives are set at the factory before shipping, but now is a good time to double-check. To inspect and adjust knife set:

1. Remove the upper cover to expose the top of the cutterhead.
2. Carefully turn the cutterhead (using the pulley) until the first knife is top dead center.
3. Using the knife adjusting jig, check the knife height. The jig should sit solidly with both feet on the cutterhead. **See Figure 13.** If the knife is adjusted properly, the contact point at the center of each adjuster should just touch the tip of the knife. If the knife does not make contact, or if the knife causes the adjuster's legs to not seat on the cutterhead, the knives need to be adjusted.

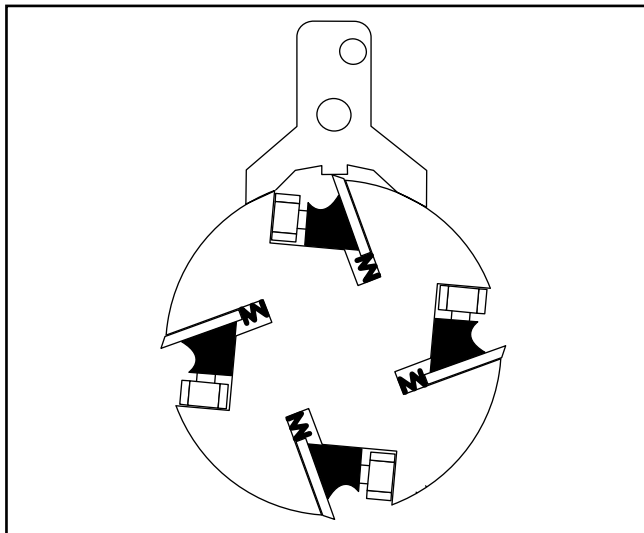

Figure 13. Knife height adjustment.



Knife Adjustment

The knives are locked into the cutterhead with wedge type gibs and gib bolts. Springs under the knives give an upward pressure to help in the setting process. To re-align the knives:

1. Loosen the gib bolts until the knife is forced upward by the springs. The gib bolts turn clockwise to loosen and counterclockwise to tighten (when facing the head of the bolt). **See Figure 14.**
2. Place the adjusters on the cutterhead as described above, so the feet are securely planted on the cutterhead. Make sure the adjuster extension rod is parallel to the cutterhead, so both ends of the knife receive equal pressure from the adjuster.
3. The downward pressure provided by the adjuster will set the knives at a uniform protrusion of approximately $.070$ " above the cutter. The knife height should vary no more than $.001$ " across the length of the cutterhead.
4. Maintain a constant pressure on the adjuster while re-tightening the gib bolts.
5. Repeat the same procedure on the remaining knives. As mentioned before, the standard adjuster is satisfactory for reasonably accurate knife setting tasks.

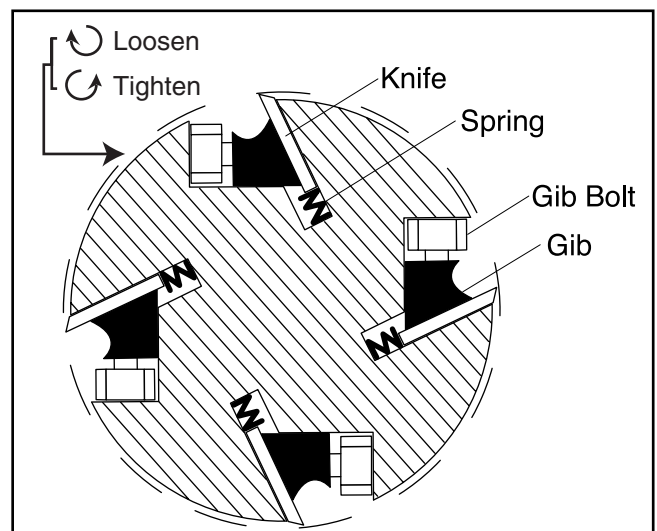

Figure 14. Cutterhead assembly.

Feed Roller Speed

The infeed and outfeed rollers power the stock through the planer. They keep boards flat and provide smooth movement. The power feed features two feed rates - 16 FPM and 20 FPM. The speed can be changed by moving the feed control knob when the machine is running. **See Figure 15.** Moving the knob toward the machine (Pos B) produces the 20 FPM feed speed, away from the machine (Pos D) produces 16 FPM and a center position (Pos C) places the gearbox in neutral.

NOTICE

The feed rate must be set before feeding lumber into the planer. **DO NOT** attempt to change speeds after the planing operation has begun. Damage to the gearbox will result.

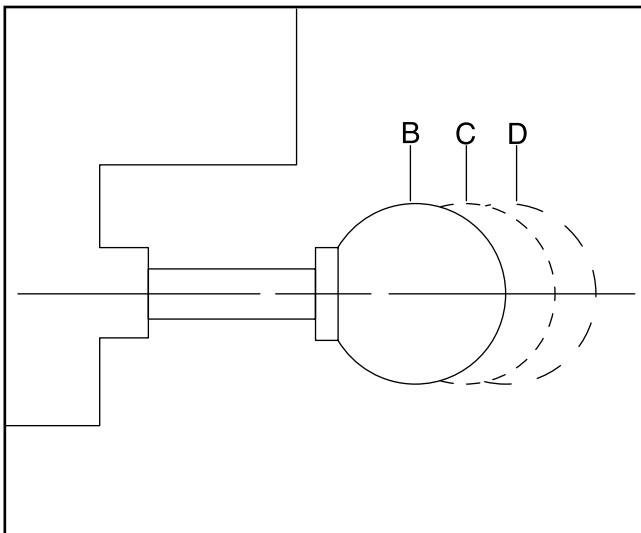

Figure 15. Feed speed control.



Roller Adjustment

The infeed and outfeed rollers must be set at .040" below the level of the cutting edge of the knives. To set the height of the infeed and outfeed rollers:

1. Disconnect the planer from its power source.
2. Make sure the knives are set correctly.
3. Remove the chain cover. Refer to the pre-run check for removal instruction.
4. Loosen the cap screw that holds the static chain tensioner and swing the tensioner out of the way. **See Figure 16.**

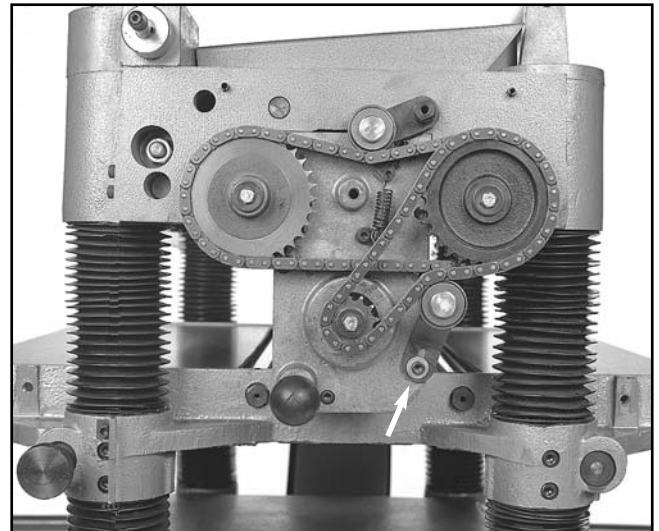

Figure 16. Static chain tensioner adjustment.

5. Place Block "A" under the cutterhead with a .040" feeler gauge above it and raise the table until the block reaches the cutterhead. Center one of the knives at the bottom of the cutterhead as you raise the table. Rock the cutterhead backward and forward as you raise the table and stop when the knife just touches the feeler gauge. **See Figure 17.**
6. The table is now positioned correctly. Lock the table in place.
7. Remove the feeler gauge and move the block to the right end of the infeed drive roller.

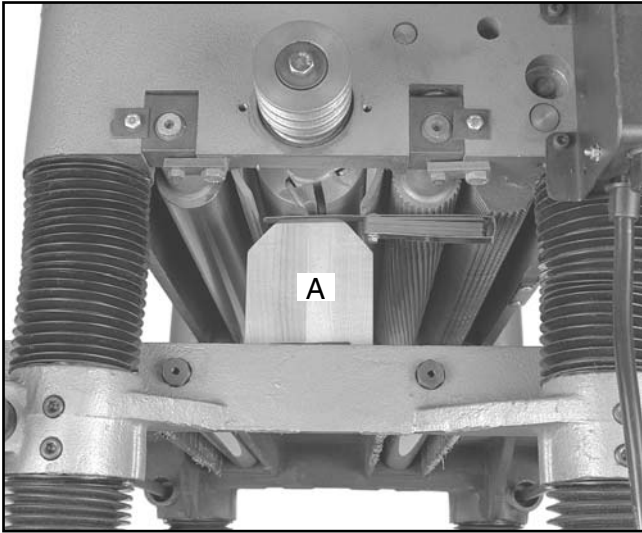

Figure 17. Feeler measures roller adjustment.

8. Move the feed speed control knob to the center neutral position.
9. Rotate the sprocket at the end of the infeed roller. The teeth at the bottom of the roller should contact the top of the block if the roller is properly adjusted. If the roller teeth will not clear the block, or if there is a gap between the block and the infeed roller, you will need to make adjustments.
10. If you need to adjust the roller up or down, loosen the lock nut and turn the setscrew to raise or lower the rollers. **See Figure 18.**

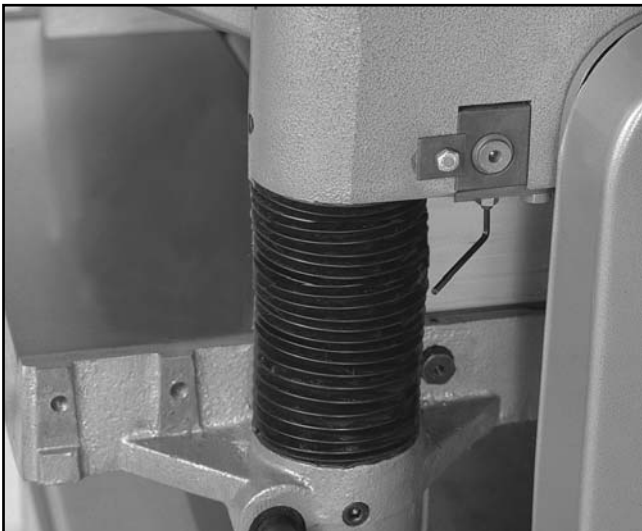

Figure 18. Adjusting roller height.

11. Follow the same procedure at the other end of the infeed roller and on both sides of the outfeed roller. Do not change the table height yet, the next sections will require the same settings.
12. Be sure to tighten the lock nut as soon as you have adjusted each roller to its proper height.



Spring Tension

Roller spring tension must be adjusted so that roller pressure is uniform. To adjust roller spring tension:

1. Locate the four adjustment screws located on the top of the planer. **See Figure 19.**
2. Adjust screws #1 - #3 so that they protrude $\frac{1}{8}$ " above the head casting.
3. Adjust screw #4 so that it protrudes $\frac{5}{16}$ " above the head casting.

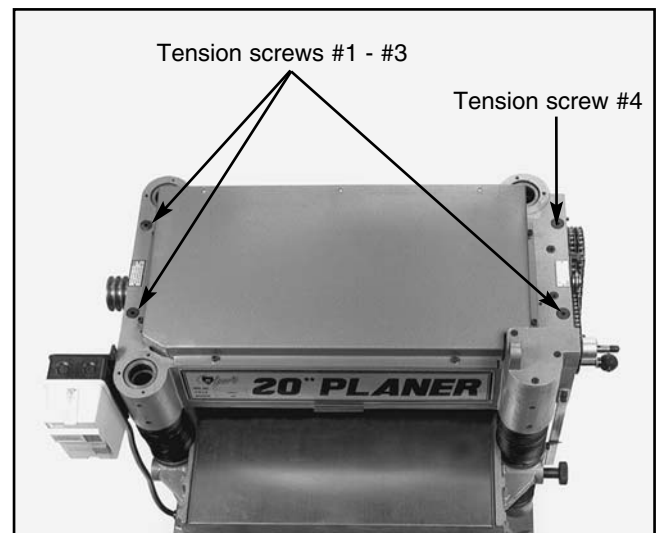

Figure 19. Tension screw locations.



Chipbreaker

The chipbreaker breaks chips/curls as they are cut by the cutterhead and forces chips to eject from the cutting area. Due to its functions within the planer, the chipbreaker should be adjusted carefully and checked frequently for movement. To adjust the chipbreaker:

1. Disconnect planer from its power source and remove the top cover. Note the location of the setscrews and lock nuts. **See Figure 20.**



Figure 20. Chipbreaker adjustment.

2. Place your test block under the middle of the chipbreaker (the table should still be at the same height as it was when you set the infeed and outfeed rollers).
3. Loosen the lock nuts at both ends of the chipbreaker and turn the setscrews to raise or lower the chipbreaker as necessary. The chipbreaker will move evenly, so it does not matter which setscrew you turn. (You will need to raise the second setscrew if the chipbreaker needs to be lowered).
4. When the chipbreaker reaches its proper height .040" below the cutterhead height, tighten the lock nut and adjust the other setscrew and lock nut to match.



Pressure Bar

Like the chipbreaker, the pressure bar controls lumber as it passes under the cutterhead. The pressure bar keeps lumber from lifting after it has been planed. If the pressure bar is incorrectly positioned, a number of machining defects (including snipe and board lines) can result. A pressure bar set too low can also place excess load on the planer's motor. The pressure bar should be adjusted along with the infeed and outfeed rollers. To adjust the pressure bar:

1. Disconnect the planer from its power supply.
2. Remove top cover. Note setscrew and lock nut pictured in **Figure 21.** Loosen the lock nuts.

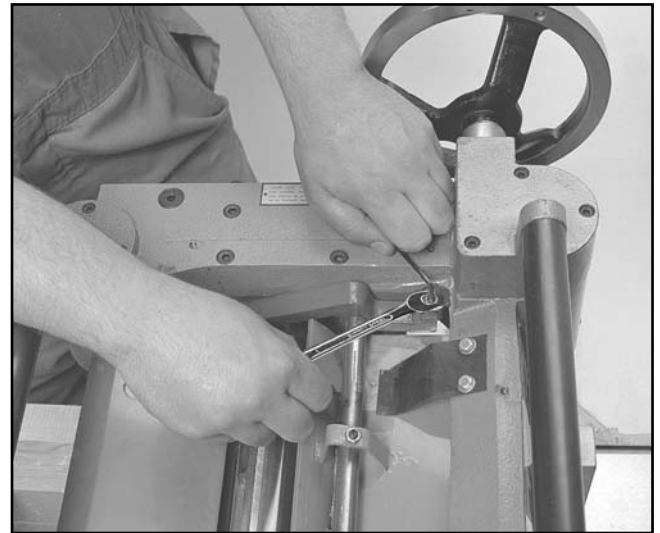

Figure 21. Pressure bar adjustment.

3. Place the gauge block under the center of the pressure bar and adjust the setscrew until the pressure bar makes slight contact with the tip of the block. Like the chipbreaker, the pressure bar can be adjusted with one setscrew. Make sure to adjust the second setscrew to match the one you've just adjusted.
4. Tighten the lock nut in place.



Chip Deflector

The chip deflector keeps chips from falling onto the outfeed roller. To adjust the deflector:

1. Disconnect the planer from its power source and remove the planer's dust cover.
2. Loosen the deflector's mounting bolts. See the parts diagram for location.
3. Make sure the deflector is beveled toward the cutterhead. Move the deflector until the edge is approximately $\frac{1}{16}$ " from the tip of the cutting knives. Rotate the cutterhead to ensure clearance.
4. Re-tighten the mounting bolts and return the top cover to the planer.

NOTICE

When using a dust collector, it may be necessary to increase the distance from the cutterhead/knives to the deflector to aid in chip removal.



Static Chain Adjuster

Once the rollers, chip breaker and pressure bar are properly adjusted, you will need to reset the static chain tensioner. Proper tensioner adjustment is crucial to your planer's operation. Not only will it have a direct effect on the quality of your work, incorrect tension on the drive chain may cause the rollers to jam, or cause the chain to break. To adjust the static chain tensioner:

1. Place the test block under the right side of the outfeed roller. Make sure that the block and the roller are in slight contact.
2. Note the height of the table on the metric portion of the scale below the handwheel. Crank the handwheel until the table moves one millimeter towards the head casting. The outfeed roller will have lifted .040".
3. Rotate the static chain tensioner up until the chain is tight. **See Figure 22.**

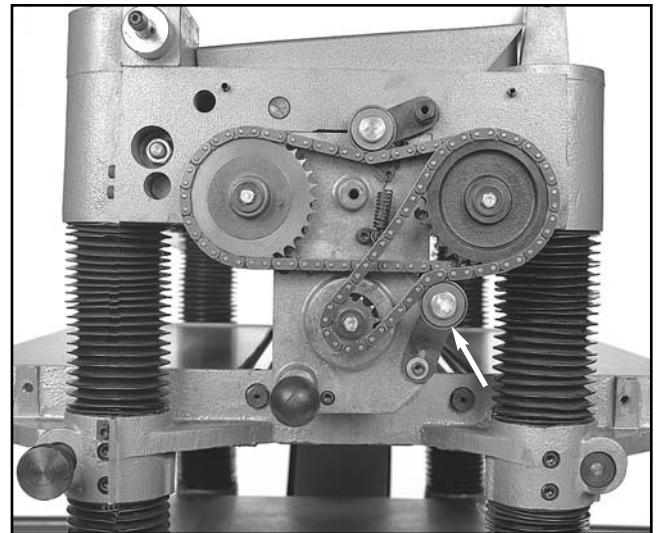

Figure 22. Chain tensioner adjustment.

4. Once the chain is tight, secure the screw that holds it in place and lower the table until you can remove the block.
5. When the tensioner is correctly adjusted, replace the backing plate and the chain drive cover.



Scale Adjustment

The scale can be adjusted for accuracy. The machine will need to be run to make proper adjustments. Follow the directions on the following page for a test run before attempting to make adjustments. Once you've successfully tested the planer:

1. Set the table to the approximate thickness of your test lumber. Measure the lumber with calipers to determine its exact thickness.
2. Move the table to $\frac{1}{16}$ " under the thickness of your lumber and feed your test board through the planer.
3. Turn the handwheel one full rotation and run the board through once more. Turn the board over and repeat.
4. Re-measure the board and compare your results with the scale. If there is a discrepancy, loosen the Allen® head bolts and adjust to match your findings. **See Figure 23.**

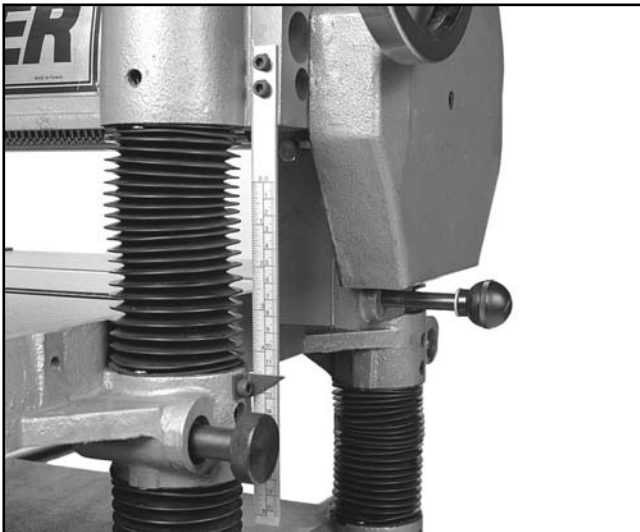

Figure 23. Cutterhead height scale.



Anti-Kickback Fingers

The Model G1033 provides an anti-kickback system as a safety feature. The anti-kickback fingers hang from a rod suspended across the cutterhead casting. The anti-kickback fingers should be inspected regularly. Check the fingers to ensure that they swing freely and easily. **See Figure 24.** Do not apply oil or other lubricants to the anti-kickback fingers. Oil or grease will attract dust, restricting the free movement of the fingers.

WARNING

Proper operation of the anti-kickback fingers are essential for the safe operation of this machine. Failure to ensure that they are working properly could result in serious operator injury.



Figure 24. Anti-kickback fingers.



SECTION 6: Operations

Test Run

Once the assembly is complete and the adjustments are done to your satisfaction, you are ready to test the machine.

Turn on the power supply at the main panel. Press the START button. Make sure that your finger is poised on the STOP button, just in case there is a problem. The planer should run smoothly, with little or no vibration or rubbing noises. Strange or unnatural noises should be investigated and corrected before operating the machine further.

WARNING

DO NOT attempt to investigate or adjust the machine while it is running. Wait until the machine is turned off, unplugged and all working parts have come to a rest before you do anything!

If noises occur that cannot be found by visual inspection, feel free to contact our service department for help.

WARNING

Operating this equipment has the potential for flying debris to cause eye injury. Always wear safety glasses or goggles when operating equipment. Everyday glasses or reading glasses only have impact resistant lenses, they are not safety glasses. Be certain the safety glasses you wear meet the appropriate standards of the American National Standards Institute (ANSI).



Operational Tips

1. Inspect lumber for defects, warping, cupping, twisting, and for foreign objects (nails, staples, imbedded gravel, etc.). If you have any question about the quality of your lumber, do not use it. Remember, wood stacked on a concrete floor can have small pieces of stone or concrete pressed into the wood.
2. Use the full width of the planer. Alternate between the left, the right and the middle when feeding lumber into the planer. Your knives will remain sharp much longer.
3. Scrape all glue off of joined boards before planing.
4. Plane **ONLY** natural wood fiber. No wood composites.
5. Surface wood with the grain. **NEVER** feed end-cut or end-grained lumber into your planer.
6. Do not use boards with knots, splits, cross-grain or other obvious blemishes or defects. They can damage the machine and pose the possibility of operator injury.
7. Keep your work area clear.
8. When making multiple passes through the planer on long stock, use the stock return rollers on the top of the machine to move the material back to the infeed side of the machine.
9. Avoid planing wood with a high water content. Wood with more than 20% moisture content or wood exposed to rain or snow, will plane poorly and cause excessive wear to the knives and motor. Excess moisture can also hasten rust and corrosion.



Wood Characteristics

The species of wood, as well as condition, will affect planing ability. The harder the wood, the more difficult it will be to plane. We've included below, a list of wood characteristics you may encounter when planing. The following descriptions of defects will give you some possible answers to problems you may encounter while planing different materials. Possible solutions follow the descriptions.

Chipped Grain - usually a result of cutting against the grain, or planing wood with knots or excessive amount of cross grain. Chipped grain can also be caused by dull knives or misaligned chipbreaker. Often, chipped grain can be avoided by slowing down the feed rate and by taking shallow cuts. If those options do not work, inspect your lumber and determine if its grain pattern is causing the problem. If the wood does not show substantial crossgrain, inspect your knives for sharpness and inspect the chipbreaker for proper alignment. See the Adjustment Section.

Fuzzy Grain - Usually caused by surfacing lumber with too high a moisture content. Sometimes fuzzy grain is a characteristic of some woods, such as basswood. Fuzzy grain can also be caused by dull knives or an incorrect grinding bevel. Check with a moisture meter. If moisture is greater than 20%, sticker the wood and allow to dry. Otherwise, inspect knife condition.

Glossy Surface - Usually caused by dull knives taking shallow cuts at a slow feed speed. Surface gloss will usually be accompanied by overheating. Often, lumber will be scorched and eventually, damage to knives will occur. If knives are sharp on inspection, increase feed speed and/or cutting depth.

Snipe - Occurs when board ends have more material removed than the rest of the board. Usually caused when one or both of the bed rollers are set too high. Can also be caused by the chipbreaker or pressure bar being set too high. However, small amount of snipe is inevitable.

Snipe can be minimized by proper adjustment of the planer's components, but complete removal of snipe is extremely unlikely. More likely, you will be able to reduce it to a tolerance of .002". If snipe under that level is a problem, consider planing lumber longer than your intended work length and cut off the excess after planing is completed.

Uneven Knife Marks - Uneven knife marks can occur when the chipbreaker is set too high. Inspect cutterhead bearings if re-adjustment of the chipbreaker fails to remedy the situation.

Chatter Marks - Usually caused by incorrect chipbreaker and pressure bar setting heights. Chatter marks can also be caused by running a narrow wood piece through the planer at either the right or left end of the cutterhead. Chatter, like uneven knife marks, will show in the form of a "washboard" look. Chatter marks are more likely to be inconsistent in appearance than uneven knife marks.

Wavy Surface - Caused by poor knife height adjustment, wavy surface appears when one knife is taking deeper cuts than the rest of the knives. Remedy by re-setting the knives to a tolerance of $\pm .001$ ".

Pitch & Glue Build-up - Glue and resin build-up on the rollers and cutterhead will cause overheating by decreasing cutting sharpness while increasing drag in the feed mechanism. The result can include scorched lumber as well as uneven knife marks and chatter.

Chip Marks - Occur when chips aren't properly expelled from the cutterhead. The knives catch the chips and drag them across the lumber being planed. Chips tend to be random and non-uniform (as compared to chipped grain). Can be caused by exhaust blockage or too much room between the cutterhead and chip deflector. Using a dust collection system in combination with the planer can help reduce chip marks. Inspect the chip deflector and readjust (as described earlier in the text).



SECTION 7: MAINTENANCE

General

Make a habit of inspecting your planer each time you use it. Check for the following conditions and repair or replace when necessary.

1. Loose mounting bolts.
2. Worn switch.
3. Worn or damaged cords and plugs.
4. Damaged V-belts.
5. Any other condition that could hamper the safe operation of this machine.

WARNING

DO NOT make adjustments or attempt any maintenance procedures while this machine is running. Ensure that the switch is off, power is disconnected and moving parts have stopped before making any adjustments. Failure to follow this directive could result in serious operator injury.



Knife Sharpening

Knife sharpness is one of the most important factors in getting good results with the planer. Knives can be made to last a long time if care is taken in checking the condition of the wood which is put into the machine. The biggest problem will come from wood with nails or other metal embedded. This will nick or chip the knives and can require a complete regrinding. Another wear factor is sand, grit, or other dirt on the surface of the wood which the knives have to cut through. At the speed the cutterhead is rotating, these types of surface contamination can have a very abrasive effect.

This planer has knives with a grind angle of 45° which is a configuration which should suit most general planing needs. The optimal grind or bevel angle is a compromise between effective cutting (the smaller the angle the better the cutting action) and edge life where the larger the angle the more the edge is supported, thus the longer it will last.

For the best results it is best to have planer knives sharpened by a professional sharpening service which has the grinding and measurement equipment to assure that the knife cutting geometry is maintained at optimum levels. It is a procedure which requires some care and precision, otherwise a set of blades can be easily ruined. Knives should always be ground as a set so they can be properly matched. Unequal material removal can result in an unbalanced cutterhead which can affect not only planing surface quality but ultimately the life of the cutterhead bearings.

Please refer to Section 5 Adjustments - Knife Adjustments for complete detail on the removal and reinstallation of the planer knives.



Lubrication

The Model G1033 features factory-sealed bearings. A sealed bearing requires no lubrication during its lifetime. Should a bearing fail, your planer will probably develop a noticeable rumble, which will increase when the machine is put under load. If allowed to get worse, overheating of the journal containing the bad bearing could occur. If the bad bearing is not replaced, it will eventually seize - possibly doing damage to other parts of the machine. Bearings are standard sizes and can be replaced through Grizzly.

Proper lubrication of other components of the Model G1033 are essential for long life and trouble-free operation. Below is a list of components that require periodic lubrication. Schedules are based on daily use. Adjust accordingly for your level of use.

Columns/Lead Screws - The four columns should be lubricated weekly with light oil. Unfasten dust covers to gain access. The four lead screws should be lubricated with general purpose grease once a month.

Worm Gear - The worm gear should be inspected monthly and lubricated when needed. Remove the worm gear box to inspect. See parts diagram for location.

Chain - The table height adjustment chain should be inspected monthly and lubricated when needed. A good quality bicycle chain lubricant works well for periodic lubrication.

Gear Box - Gear box oil should be drained after the first 20 hours of operation. **See Figure 25.** Replace with 80W-90W gear oil. Inspect levels periodically and change yearly. Replace gear oil more frequently under heavy use. Fill until oil reaches the top of the filler plug port for correct oil level.

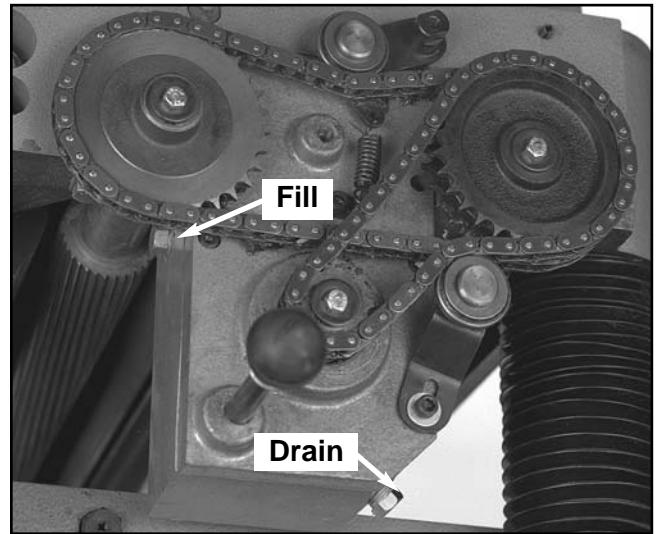

Figure 25. Gear Box drain and fill plugs.

Drive Chain - The drive chain should be inspected and lubricated monthly. Check sprocket, chain and cotter pin during inspection. Use a general purpose grease. Some chains will have master links instead of cotter pins.

Feed Rollers - Daily lubrication of feed rollers is crucial to the operation of your planer. Lubricate before start-up. Each end of each power feed roller has an oiling port located on the top of the head casting. **See Figure 26.** Apply a light oil, making sure that the lubricant penetrates the bearing.



Figure 26. Feed roller lubrication points.



Belt Tension

Inspect the belts daily for the first couple of weeks you operate the planer. This is the time that the majority of stretching will occur. Adjust belt tension by lowering the motor down slightly. **See Figure 27.** Establish a periodic schedule of inspection. Check for wear, cracking, nicks, or glazing. Replace belts immediately if you spot any signs of deterioration. Always use three belts when operating the Model G1033.

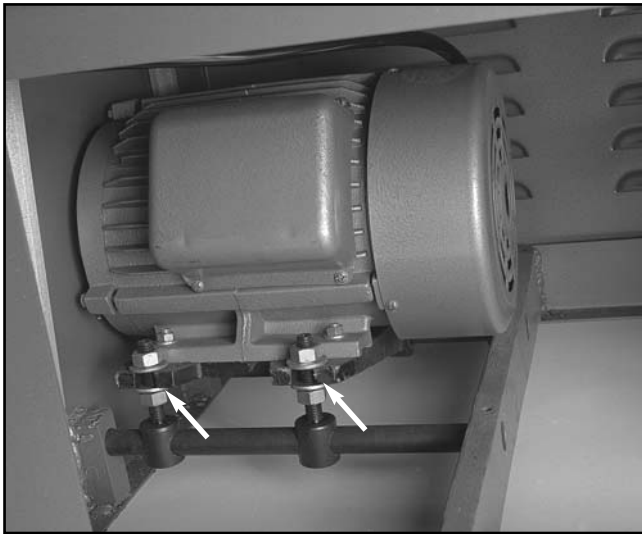

Figure 27. Adjustments for belt tension.



Belt Alignment

Proper belt alignment prevents premature belt wear. **See Figure 28.** Use a straightedge on the edge of the pulleys to judge alignment.



Figure 28. Pulley alignment procedure.

Should you find that the pulleys are out of alignment:

1. Loosen the belt tension to allow motor movement.
2. Loosen the four (4) bolts that secure the motor to the mounting plate just enough to allow the motor to be repositioned.
3. Slide the motor as required to align the pulleys..
4. Re-tighten the motor mount bolts carefully to assure that the tightening process does not move the motor.
5. Re-tension the belt as shown in the previous column.
6. Replace the belt cover.



SECTION 8: CLOSURE

The following pages contain parts diagrams, parts lists, general machine data and warranty/return information for your Model G1033 Planer.

If you need parts or help in assembling your machine, or if you need operational information, we encourage you to call the Grizzly Industrial Service Department. Our trained service technicians will be glad to help you.

If you have comments dealing specifically with this manual, please write to our Bellingham, Washington location using the address in the Introduction. The specifications, drawings, and photographs illustrated in this manual represent the Model G1033 as supplied when the manual was prepared. However, due to Grizzly's policy of continuous improvement, changes may be made at any time with no obligation on the part of Grizzly. Whenever possible, though, we send manual updates to all owners of a particular tool or machine. Should you receive one, add the new information to this manual and keep it for reference.

We have included some important safety measures that are essential to this machine's operation. While most safety measures are generally universal, Grizzly reminds you that each workshop is different and safety rules should be considered *as they apply to your specific situation*.

We recommend you keep a copy of our current catalog for complete information regarding Grizzly's warranty and return policy. If you need additional technical information relating to this machine, or if you need general assistance or replacement parts, please contact the Service Department listed in *Section 3: Introduction*.

Additional information sources are necessary to realize the full potential of this machine. Trade journals, woodworking magazines, and your local library are good places to start.

WARNING

The Model G1033 was specifically designed for wood cutting operations. DO NOT MODIFY AND/OR USE THIS PLANER FOR ANY OTHER PURPOSE. Modifications or improper use of this tool will void the warranty. If you are confused about any aspect of this machine, DO NOT use it until you have answered all your questions. Serious injury may occur.

WARNING

Like all power tools, there is danger associated with the Model G1033 20" Planer. Accidents are frequently caused by lack of familiarity or failure to pay attention. Use this tool with respect and caution to lessen the possibility of operator injury. If normal safety precautions are overlooked or ignored serious personal injury may occur.





MACHINE DATA SHEET

Customer Service #: (570) 326-3806 • To Order Call: (800) 523-4777 • Fax #: (800) 438-5901

GRIZZLY MODEL G1033 20" PLANER

Design Type Floor Model

Overall Dimensions:

Table Size25³/₄" x 20"
 Height.....41"
 Overall Depth39"
 Overall Width58"
 Shipping Weight770 lbs.
 Base Dimensions27¹/₂" L x 23" W x 13³/₄" H
 Crate Size29" L x 40" W x 44" H
 Footprint22" x 28"

Capacities:

Maximum Depth of Cut1/8"
 Maximum Width of Cut.....20"
 Maximum Cutting Height.....8⁵/₈"
 Minimum Stock Thickness1/4"
 Minimum Stock Length7"
 Cutterhead Speed4833 RPM
 Cuts per Minute19,332
 Feed Rates16 FPM & 20 FPM
 Cuts Per Inch104 & 83

Construction:

TablePrecision-Ground Cast Iron
 Power Feed RollersMetal/ Spiral Serrated
 StandFormed Steel
 CutterheadOne Piece Machined Shaft; 4 Knife Slots w/ Shielded Ball Bearings

Motor:

TypeTEFC Capacitor-Start Induction
 Horsepower3HP
 Phase / VoltageSingle Phase / 220V / 240V
 Amps18
 Cycle / RPM60 Hertz / 3450 RPM
 SwitchMagnetic With Thermal Overload Protector
 Power TransferTriple Belt Drive
 Bearings.....Shielded & Permanently Lubricated Ball

Features:

Roller Extension Tables1 Adjustable Roller
 Table Movement1/4" to 8¹/₂"
 Table Locks.....Two Positive
 Dust Port5"
 Measurement ScaleInch & Metric
 Bed Rollers2 Adjustable

Specifications, while deemed accurate, are not guaranteed.

REVISED 4/99

TROUBLESHOOTING

This section covers the most common processing problems encountered in planing and what to do about them. Do not make any adjustments until planer is unplugged and moving parts have come to a complete stop.

SYMPTOM	POSSIBLE CAUSE	CORRECTIVE ACTION
Motor will not start.	<ol style="list-style-type: none"> 1. Low voltage. 2. Open circuit in motor or loose connections. 	<ol style="list-style-type: none"> 1. Check power line for proper voltage. 2. Inspect all lead connections on motor for loose or open connections.
Motor will not start; fuses or circuit breakers blow.	<ol style="list-style-type: none"> 1. Short circuit in line cord or plug. 2. Short circuit in motor or loose connections. 3. Incorrect fuses or circuit breakers in power line. 	<ol style="list-style-type: none"> 1. Inspect cord or plug for damaged insulation and shorted wires. 2. Inspect all connections on motor for loose or shorted terminals or worn insulation. 3. Install correct fuses or circuit breakers.
Motor overheats.	<ol style="list-style-type: none"> 1. Motor overloaded. 2. Air circulation through the motor restricted. 	<ol style="list-style-type: none"> 1. Reduce load on motor. 2. Clean out motor to provide normal air circulation.
Motor stalls (resulting in blown fuses or tripped circuit).	<ol style="list-style-type: none"> 1. Short circuit in motor or loose connections. 2. Low voltage. 3. Incorrect fuses or circuit breakers in power line. 4. Motor overloaded. 	<ol style="list-style-type: none"> 1. Inspect connections on motor for loose or shorted terminals or worn insulation. 2. Correct the low voltage conditions. 3. Install correct fuses or circuit breakers. 4. Reduce load on motor.
Machine slows when operating.	<ol style="list-style-type: none"> 1. Feed rate too high. 2. Depth of cut too great. 	<ol style="list-style-type: none"> 1. Feed workpiece slower. 2. Reduce depth of cut.
Loud, repetitious noise coming from machine	<ol style="list-style-type: none"> 1. Pulley setscrews or keys are missing or loose. 2. Motor fan is hitting the cover. 3. V-belt is defective 	<ol style="list-style-type: none"> 1. Inspect keys and setscrews. Replace or tighten if necessary. 2. Tighten fan or shim cover. 3. Replace V-belt. See Maintenance.
Machine is loud when cutting. Overheats or bogs down in the cut.	<ol style="list-style-type: none"> 1. Excessive depth of cut. 2. Knives are dull 	<ol style="list-style-type: none"> 1. Decrease depth of cut. 2. Sharpen knives.
Infeed roller marks are left on the workpiece.	Depth of cut too shallow.	Increase depth of cut.
Outfeed roller marks are left on right side of workpiece.	Too much spring tension on feed roller.	Refer to Adjustments, Spring Tension .
Cannot control snipe.	Long or heavy board sags as it enters and exits.	Lift up on unsupported end of board as it enters and exits cutterhead.
Chip buildup on outfeed roller.	Chips working their way back under the chip deflector.	Lay duct tape over the mounting bolts along the outside edge to seal any possible gaps.
Machine howls on startup.	Chip deflector too close to the cutterhead.	Move back 1/8" to 1/4" from the cutterhead.
Table moves down while cutting.	Knives dull	Replace knives.

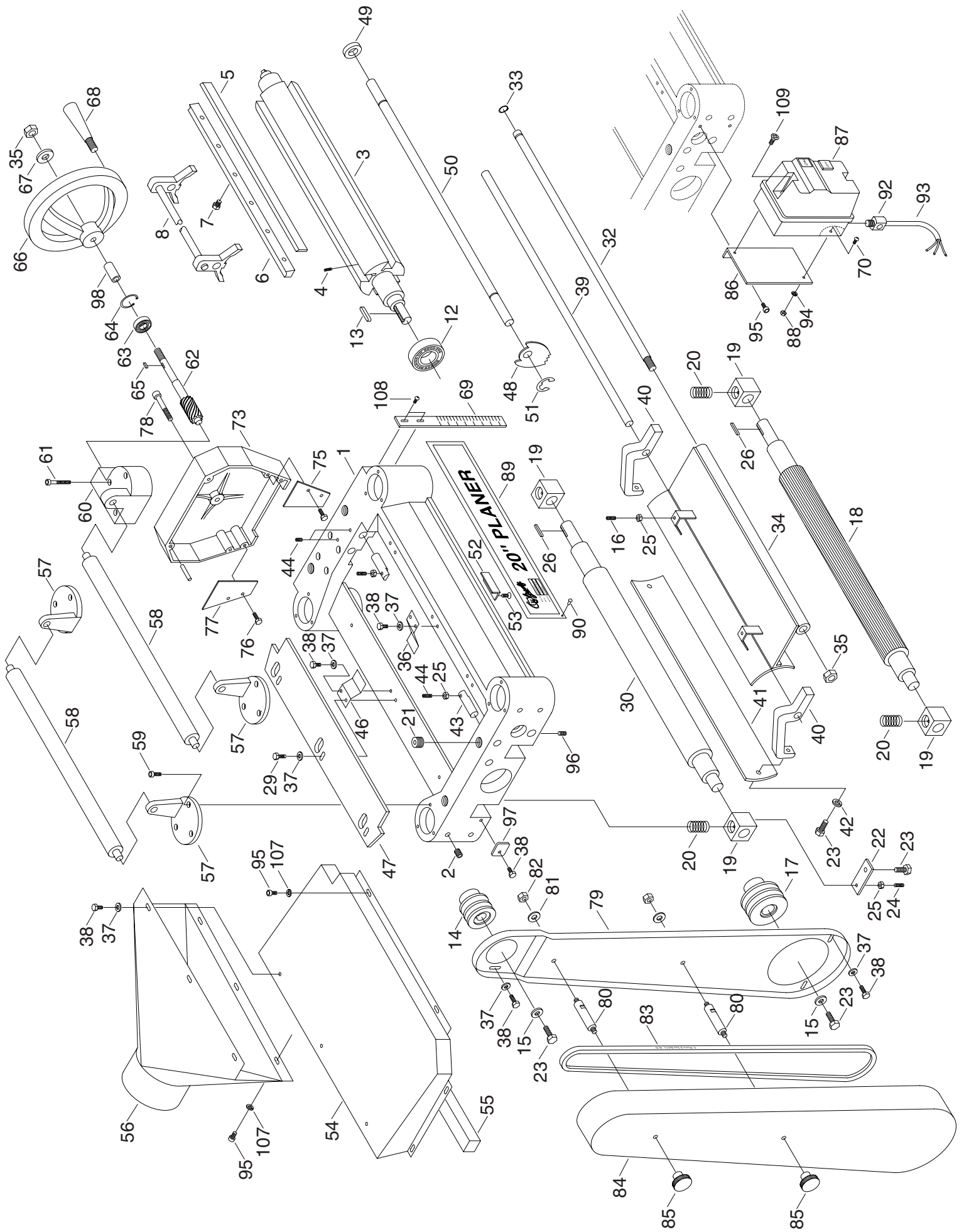

REF	PART #	DESCRIPTION
01	P1033001	HEADCASTING
02	PSS13M	SETSCREW M10-1.5 X 12
03	P1033003	CUTTERHEAD
04	P1021103	SPRING
05	P1033005	BLADES FOR PLANER
06	P1033006	GIB
07	PB17M	HEX BOLT M8-1.25 X 10
08	P1021166	KNIFE GAUGE W/BAR
12	P6206	BEARING 6206
13	PK09M	KEY 8 X 8 X 36
14	P1021007	CUTTERHEAD PULLEY
15	P1033015	WASHER 5/16" X 1 3/16"
16	PSS12M	SETSCREW M6-1.0 X 25
17	P1021008	MOTOR PULLEY
18	P1033018	INFEED ROLLER
19	P1021153	BUSHING BLOCK
20	P1021152	SPRING
21	P1033021	SPECIAL SETSCREW
22	P1021092	PLATE
23	PB09M	HEX BOLT M8-1.25 X 20
24	PSS11M	SETSCREW M6-1.0 X 16
25	PN01M	HEX NUT M6-1.0
26	PK21M	KEY 5 X 5 X 23
29	PB18M	HEX BOLT M6-1.0 X 15
30	P1033030	OUTFEED ROLLER
31	P1021149	SPROCKET
32	P1033032	LOCKING ROD
33	PR03M	SNAP RING 12MM
34	P1033034	CHIP BREAKER
35	PN09M	HEX NUT M12-1.75
36	P1021028	CHIP BREAKER SPRING
37	PW03M	FLAT WASHER 6MM
38	PB03M	HEX BOLT M6-1 X 12
39	P1033039	SHAFT
40	P1033040	BRACKET
41	P1033041	PRESSURE PLATE
42	PLW04M	LOCK WASHER 8MM
43	P1033043	SHAFT
44	PSS11M	SETSCREW M6-1.0 X 16
45	PSS11M	SETSCREW M6-1.0 X 16
46	P1033046	SPRING PLATE
47	P1033047	CHIP DEFLECTOR PLATE
48	P1021161	ANTI-KICKBACK FINGER
49	P1021160	SPACER
50	P1033050	SHAFT
51	PEC06M	E-CLIP 20MM
52	P1033052	DEPTH LIMITER

REF	PART #	DESCRIPTION
53	PFH02M	FLT HD SCR M6-1.0X12
54	P1033054	UPPER COVER
55	P1033055	GASKET
56	P1033056	COLLECTOR
57	P1033057	ROLLER STAND
58	P1033058	ROLLER
59	PSB01M	CAP SCREW M6-1.0 X 16
60	P1033060	WORM GEAR BOX
61	PSB37M	CAP SCREW M6-1.0 X 50
62	P1033062	WORM
63	P6201	BEARING 6201
64	PR29M	SNAP RING 32MM
65	PK05M	KEY 4 X 4 X 10
66	P1033066	HANDWHEEL
67	P1033067	WASHER 1/2" X 1 1/8"
68	P1021032	HANDLE
69	P1033069	SCALE
70	PS08M	PHLP HD SCR M5-0.8X12
73	P1033073	COVER
75	P1033075	SAFETY HATCH
76	PB04M	HEX BOLT M6-1.0X10
77	P1033077	SAFETY HATCH
78	PSB12M	CAP SCREW M8-1.25 X 16
79	P1033079	PULLEY GUARD
80	P1033080	STUD
81	PW07	FLAT WASHER 5/16"
82	PN02	HEX NUT 5/16" X 18
83	PVM59	V-BELT M59 3L590
84	P1033084	PULLEY COVER
85	P1033085	KNOB
86	P1033086	SWITCH BRACKET
87	G4573	MAGNETIC SWITCH
88	PN06M	HEX NUT M5-0.8
89	P1033089	NAME PLATE
90	P1183095	RIVET
91	P1033091	CHAIN 33 LINKS
92	P1071075	STRAIN RELIEF
93	P1033093	POWER CORD
94	P1033094	STAR WASHER #10
95	PSB04M	CAP SCREW M6-1.0X10
96	PSS14M	SETSCREW M8-1.25X12
97	P1033097	RETAINER
98	P1033098	COLLAR
107	PLW03M	LOCK WASHER 6MM
108	PS09M	PHLP HD SCR M5-0.8X10
109	PSW01-1	PLASTIC SCREW

REF	PART #	DESCRIPTION
01	P1033201	MIDDLE TABLE
02	P1033202	ROLLER
03	P6201	BEARING 6201
04	P1033204	ECCENTRIC SHAFT
05	PSS04M	SETSCREW M6-1.0X12
06	P1021143	THREADED GIB
07	P1033207	LOCK ROD
08	P1021146	GIB
09	P1021145	KNOB

REF	PART #	DESCRIPTION
10	PSB14M	CAP SCREW M10-1.25X20
11	P1033211	EXT ROLLER BAR
12	P1033212	EXTENSION ROLLER
13	PB32M	HEX BOLT M10-1.5X25
14	PW04M	FLAT WASHER 10MM
15	P1033071	POINTER
16	PSB04M	CAP SCREW M6-1.0X10
17	PLW03M	LOCK WASHER 6MM

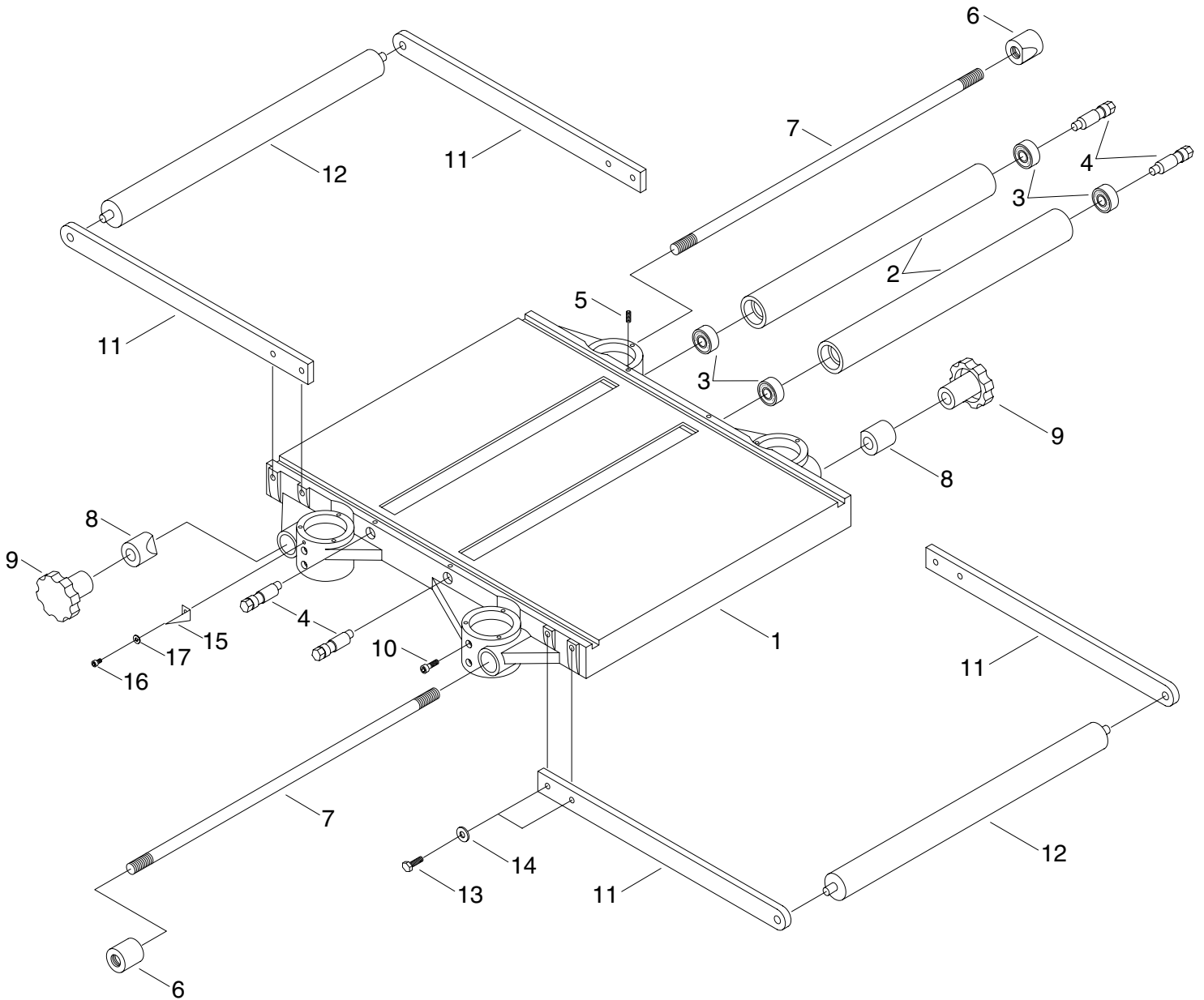

REF PART #	DESCRIPTION	
01	P1033301	BASE
02	PSS13M	SETSCREW M10-1.5 X 12
03	P1033303	COLUMN
04	P1033304	COLUMN
05	P1033305	LEADSCREW
06	P1033306	LEADSCREW
07	P1033307	LEADSCREW NUT
08	P1033308	BUSHING
09	PR22M	INT RETAINING RING 38MM
10	PK10M	KEY 5 X 5 X 12
11	P1033311	GEAR
12	PR03M	SNAP RING 12MM
13	P6202	BALL BEARING 6202
14	PR21M	SNAP RING 35MM
15	PK08M	KEY 5 X 5 X 16
16	P1033316	SPROCKET

REF PART #	DESCRIPTION	
17	P1033317	WASHER
18	PN08M	HEX NUT M10-1.25
19	PW01M	FLAT WASHER 8MM
20	PB07M	HEX BOLT M8-1.25 X 25
21	P1033321	BRACKET W/ SHAFT
23	P1033323	SPROCKET
24	PR05M	SNAP RING 15MM
25	P1033325	CHAIN
26	P1033326	CRANE POST
27	PR08M	EXT RETAINING RING 19MM
28	P1033328	PIPE BAND
29	P1033329	SCREW
30	P1033330	EXPANSION BAND
31	PB33M	HEX BOLT M12-1.75 X 50
32	PW06M	FLAT WASHER 12MM
33	PLW05M	LOCK WASHER 12MM
34	PN09M	HEX NUT M12-1.75

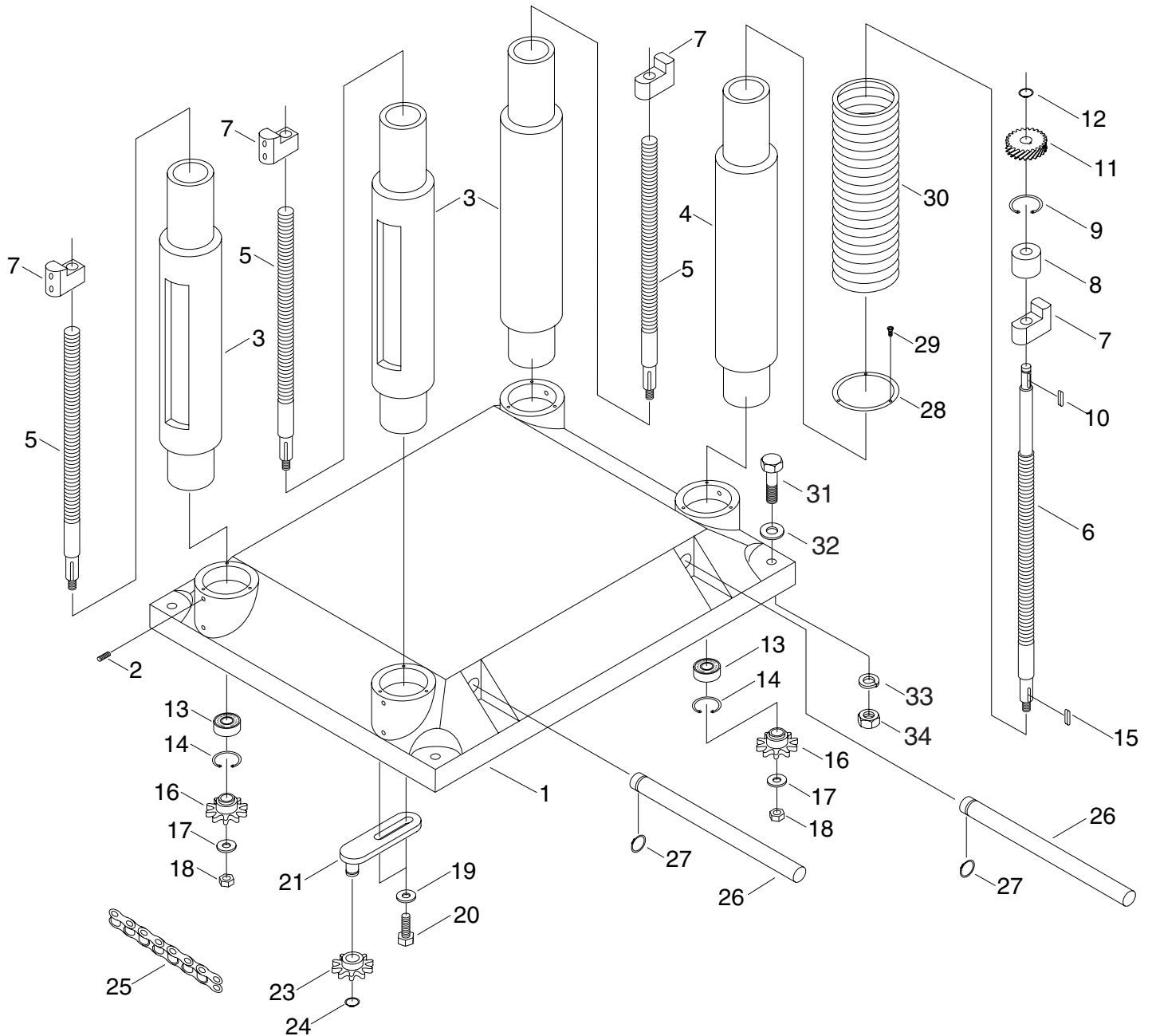

REF	PART #	DESCRIPTION
01	P1033401	STAND
02	P1033402	COVER
03	PFH06M	FLAT HD SCREW M6-1.0 X 20
04	P1033404	BAR
05	P1033405	MOTOR MOUNT
06	PSS20M	SETSCREW M8-1.25 X 8
07	P1033407	COLLAR
08	P1033408	ADJUSTABLE BOLT
09	PN09M	HEX NUT M12-1.75
10	PW01	FLAT WASHER 1/2"
11	PB07M	HEX BOLT M8-1.25 X 25
12	P1033412	WASHER 5/16" X 7/8"
13	PN03M	HEX NUT
14	P1033414	3HP MOTOR
15	PK36M	KEY 5 X 5 X 50
17	P1033417	POWER CORD
18	P1071075	STRAIN RELIEF
19	PW01M	FLAT WASHER 8MM

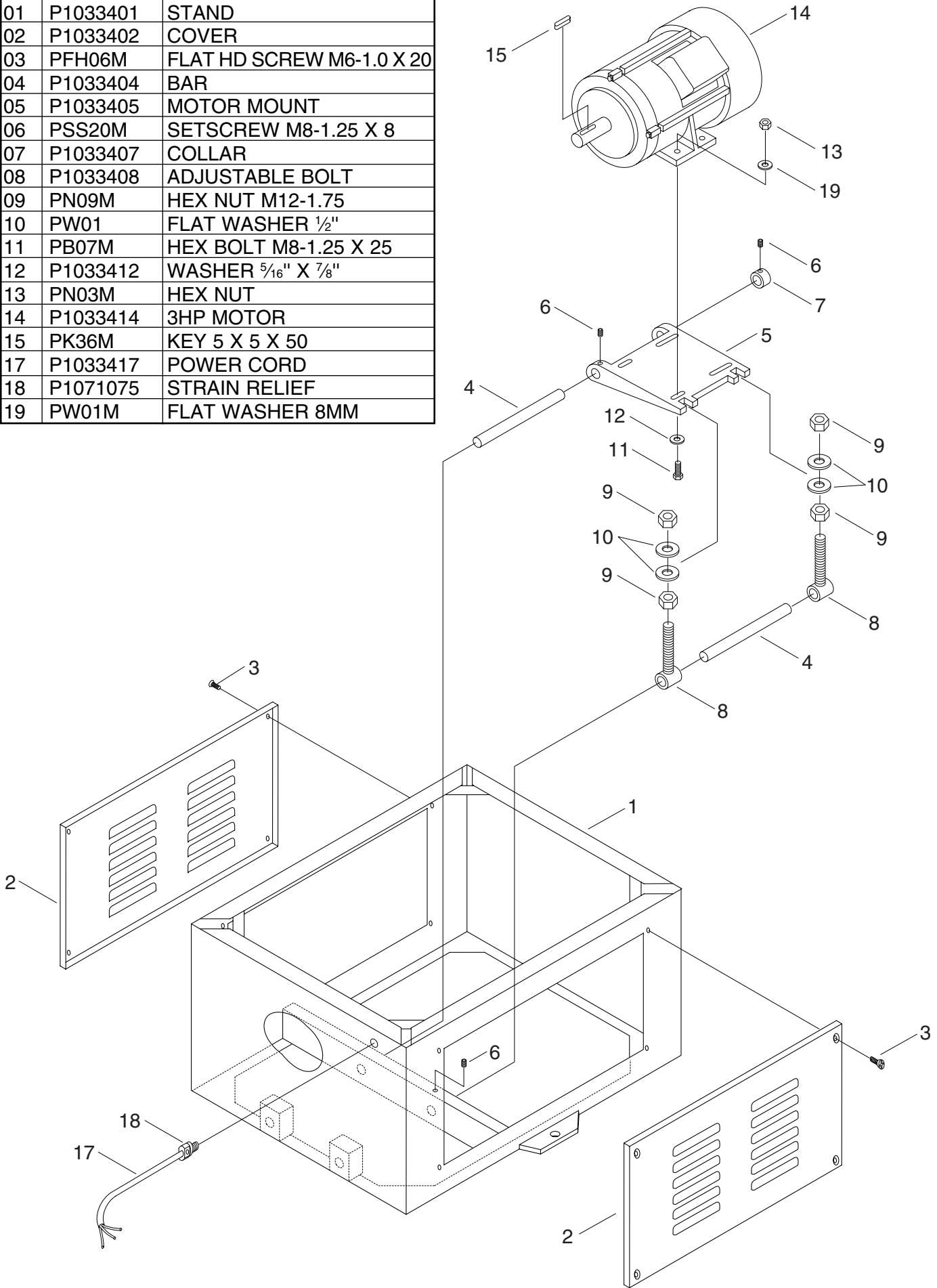

REF	PART #	DESCRIPTION
01	P1021109	GEAR BOX
02	P1021108	OIL SEAL 28-40-8
03	P6204	BALL BEARING 6204
04	P1021112	GEAR
05	PSB02M	CAP SCREW M6-1.0 X 20
06	P1033028	FLAT WASHER 1/4" X 7/8"
07	PSB28M	CAP SCREW M6-1.0 X 15
08	P6201	BALL BEARING 6201
09	P1021115	GEAR
10	P1021117	GEAR AND SHAFT
11	PK10M	KEY 5 X 5 X 12
12	P1021120	GEAR
13	PK06M	KEY 5 X 5 X 10
14	P1021119	GEAR, 2-SPEED
17	P1021121	DOUBLE GEAR
20	PK11M	KEY 6 X 6 X 40
21	P1021128	BALL 6MM

REF	PART #	DESCRIPTION
22	P1021127	SPRING
23	P1021122	SHAFT
24	P1021125	OIL SEAL 25 X 47 X 7
25	P1021137	SPROCKET
26	PK21M	KEY 5 X 5 X 23
27	P1033527	CHAIN, 25 LINKS
28	PB18M	HEX BOLT M6-1.0 X 15
29	P1021129	SHIFTER
30	P1021131	SHIFTING SHAFT HANDLE
31	PW03M	FLAT WASHER 6MM
32	PB02M	HEX BOLT M6-1.0X12
33	P1021132	O-RING 12MM
34	P1021134	KNOB
35	P1021135	PIN
36	P1021110	GASKET
37	P1021133	GEAR CASE
38	PSB06M	CAP SCREW M6-1.0X25
39	P1021107	OIL PLUG
40	PSB05M	CAP SCREW M8-1.25X50

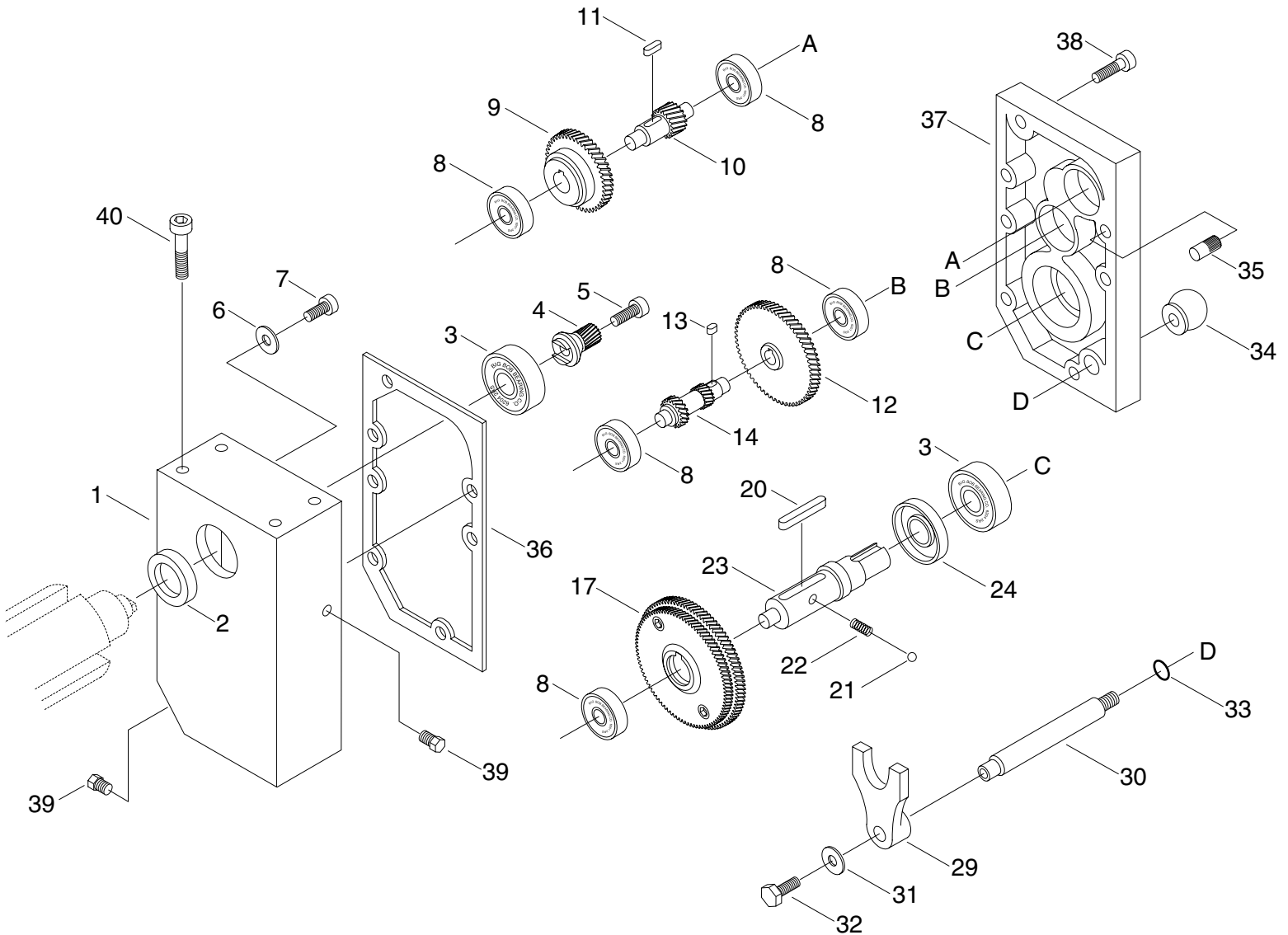

REF	PART #	DESCRIPTION
01	P1021164	SPROCKET
02	P1033028	WASHER 1/4" X 7/8"
03	PSB18M	CAP SCREW M4-0.7 X 8
04	P1021149	SPROCKET
05	PRP07M	ROLL PIN 6X20
06	P1033091	CHAIN 33 LINKS
07	PSB04M	CAP SCREW M6-1.0 X 10
08	P1033099	CHAIN TENSIONER
09	P1033102	SHAFT

REF	PART #	DESCRIPTION
10	P1033103	HANGER
11	P1033104	SPRING
12	P1033105	SPACER
13	P1033106	OUTER CHAIN TENSIONER
14	P1021137	SPROCKET
15	P1033527	CHAIN 25 LINKS
16	PSB48M	CAP SCREW M6-1.0 X 35
17	PW03M	FLAT WASHER 6MM
18	PK21M	KEY 5 X 5 X 23

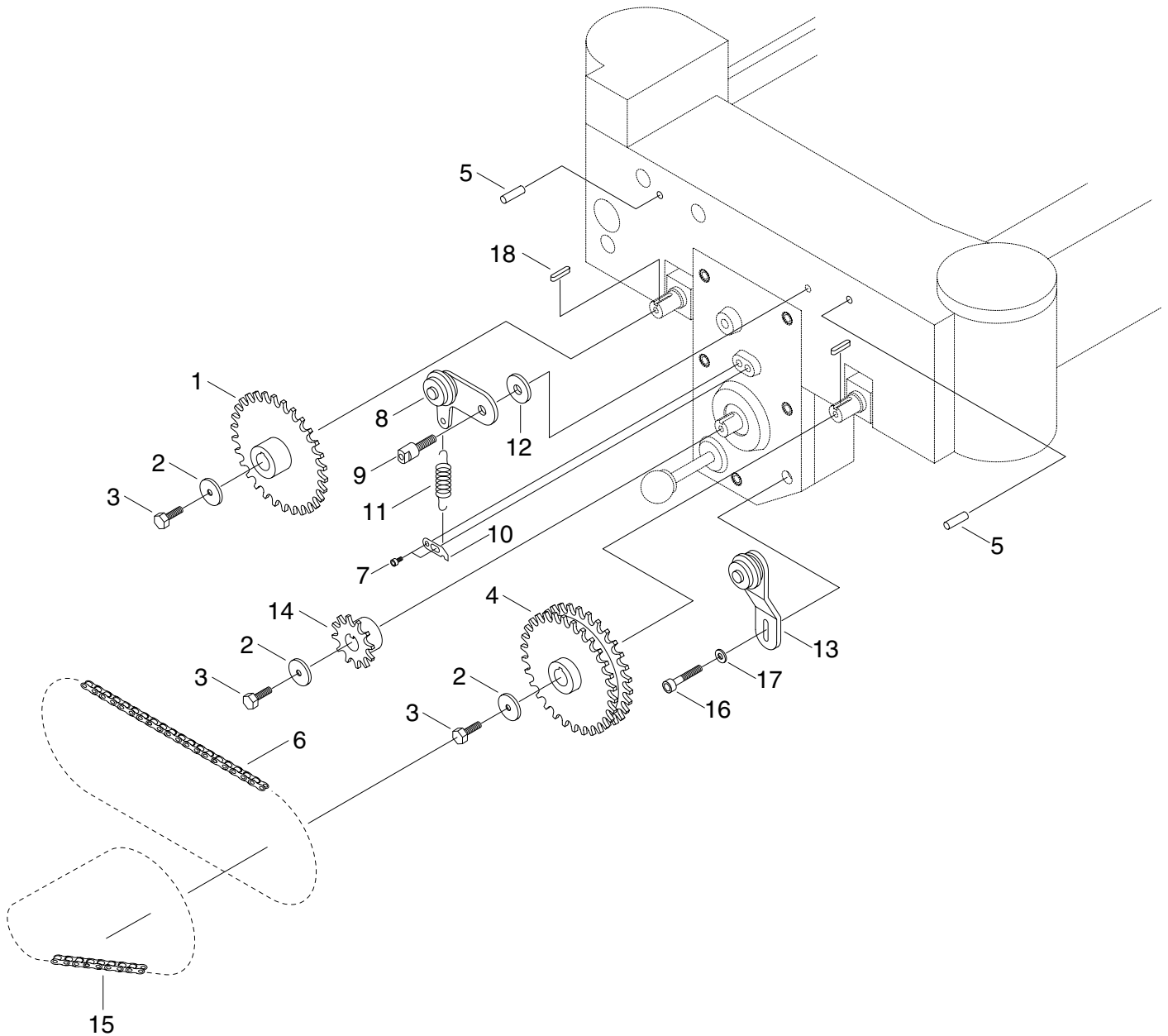

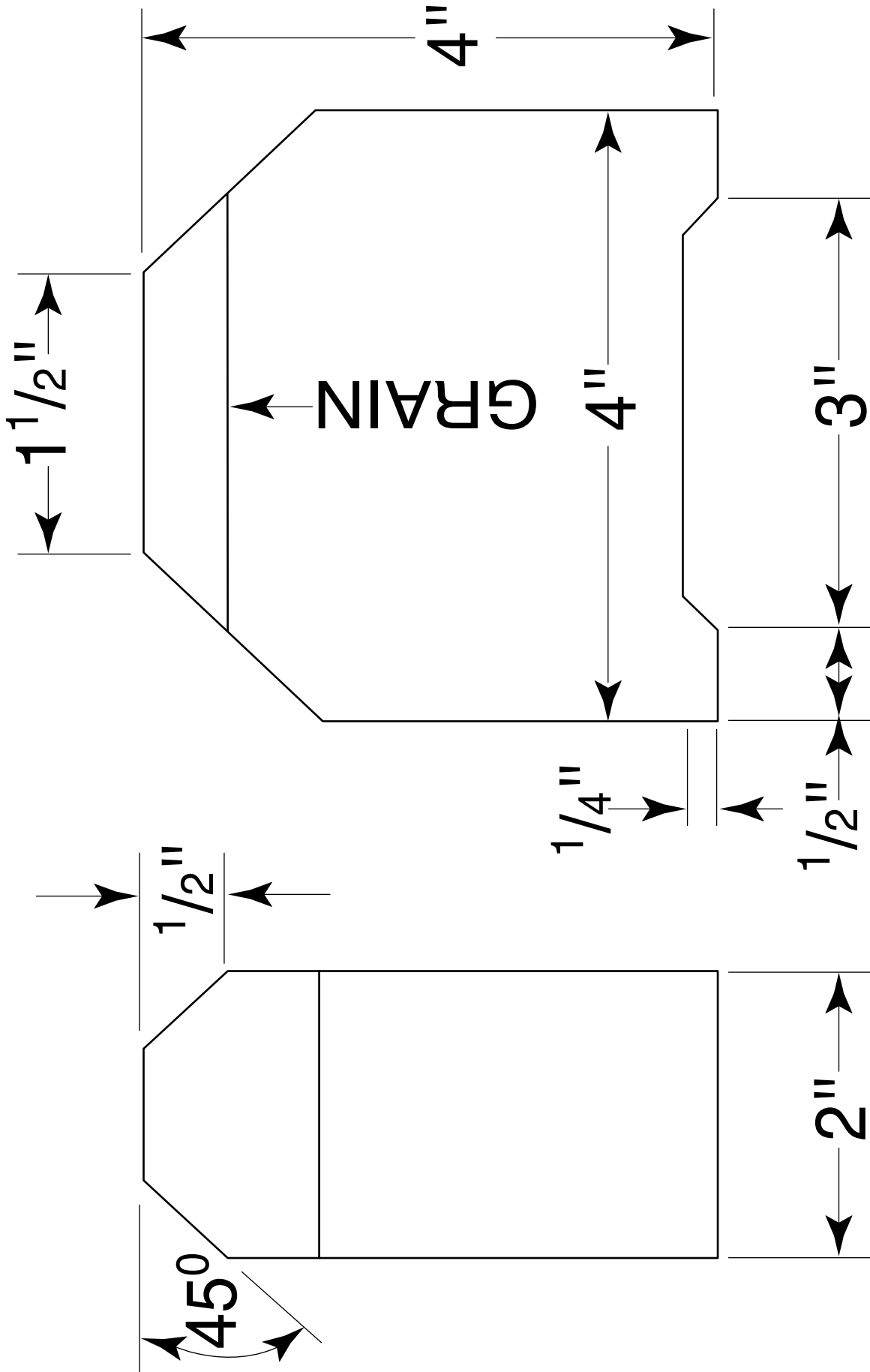

G1033 Wiring Diagram -Taian Type

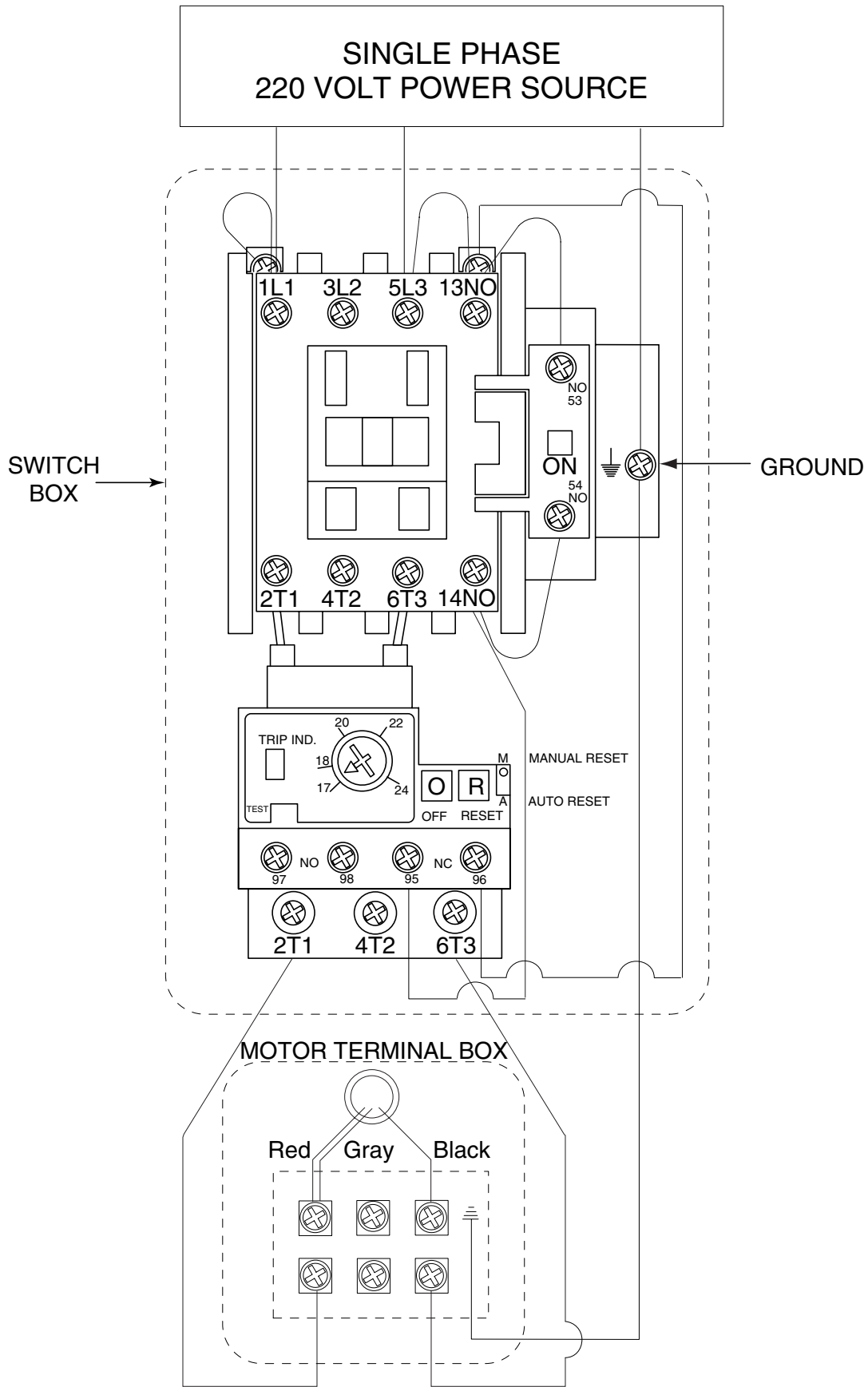

WARRANTY AND RETURNS

Grizzly Industrial, Inc. warrants every product it sells for a period of **1 year** to the original purchaser from the date of purchase. This warranty does not apply to defects due directly or indirectly to misuse, abuse, negligence, accidents, repairs or alterations or lack of maintenance. This is Grizzly's sole written warranty and any and all warranties that may be implied by law, including any merchantability or fitness, for any particular purpose, are hereby limited to the duration of this written warranty. We do not warrant or represent that the merchandise complies with the provisions of any law or acts unless the manufacturer so warrants. In no event shall Grizzly's liability under this warranty exceed the purchase price paid for the product and any legal actions brought against Grizzly shall be tried in the State of Washington, County of Whatcom.

We shall in no event be liable for death, injuries to persons or property or for incidental, contingent, special, or consequential damages arising from the use of our products.

To take advantage of this warranty, contact us by mail or phone and give us all the details. We will then issue you a "Return Number", which must be clearly posted on the outside as well as the inside of the carton. We will not accept any item back without this number. Proof of purchase must accompany the merchandise.

The manufacturers reserve the right to change specifications at any time because they constantly strive to achieve better quality equipment. We make every effort to ensure that our products meet high quality and durability standards and we hope you never need to use this warranty.

Please feel free to write or call us if you have any questions about the machine or the manual.

Thank you again for your business and continued support. We hope to serve you again soon.

WARRANTY CARD

Name _____
Street _____
City _____ State _____ Zip _____
Phone Number _____ E-Mail _____ FAX _____
MODEL # _____ Order # _____

The following information is given on a voluntary basis. It will be used for marketing purposes to help us develop better products and services. Of course, all information is strictly confidential.

- How did you learn about us?
 Advertisement Friend
 Catalog Card Deck
 World Wide Web
 Other _____
- Which of the following magazines do you subscribe to.
 American Woodworker Practical Homeowner
 Cabinetmaker Shop Notes
 Family Handyman Today's Homeowner
 Fine Homebuilding WOOD
 Fine Woodworking Wooden Boat
 Home Handyman Woodshop News
 Journal of Light Construction Woodsmith
 Old House Journal Woodwork
 Popular Mechanics Woodworker
 Popular Science Woodworker's Journal
 Popular Woodworking Workbench
 Other _____
- Which of the following woodworking/remodeling shows do you watch?
 Backyard America The New Yankee Workshop
 Home Time This Old House
 The American Woodworker Woodwright's Shop
 Other _____
- What is your annual household income?
 \$20,000-\$29,999 \$60,000-\$69,999
 \$30,000-\$39,999 \$70,000-\$79,999
 \$40,000-\$49,999 \$80,000-\$89,999
 \$50,000-\$59,999 \$90,000 +
- What is your age group?
 20-29 50-59
 30-39 60-69
 40-49 70 +
- How long have you been a woodworker?
 0 - 2 Years 8 - 20 Years
 2 - 8 Years 20+ Years
- How would you rank your woodworking skills?
 Simple Advanced
 Intermediate Master Craftsman
- What stationary woodworking tools do you own? Check all that apply.
 Air Compressor Panel Saw
 Band Saw Planer
 Drill Press Power Feeder
 Drum Sander Radial Arm Saw
 Dust Collector Shaper
 Horizontal Boring Machine Spindle Sander
 Jointer Table Saw
 Lathe Vacuum Veneer Press
 Mortiser Wide Belt Sander
 Other _____
- How many of your woodworking machines are Grizzly? _____
- Which benchtop tools do you own? Check all that apply.
 1" x 42" Belt Sander 6" - 8" Grinder
 5" - 8" Drill Press Mini Lathe
 8" Table Saw 10" - 12" Thickness Planer
 8" - 10" Bandsaw Scroll Saw
 Disc/Belt Sander Spindle/Belt Sander
 Mini Jointer
 Other _____
- How many of the machines checked above are Grizzly? _____
- Which portable/hand held power tools do you own? Check all that apply.
 Belt Sander Orbital Sander
 Biscuit Joiner Palm Sander
 Circular Saw Portable Planer
 Detail Sander Saber Saw
 Drill/Driver Reciprocating Saw
 Miter Saw Router
 Other _____
- What machines/supplies would you like Grizzly Industrial to carry?
 12" Table Saw Radial Arm Saw
 12" Jointer Panel Saw
 Combination Planer/Jointer Brass Hardware
 Paint & Finishing Supplies Lumber
 Contractor's Supplies
 Other _____
- What new accessories would you like Grizzly Industrial to carry?
 Builders Hardware Hand Tools
 Fasteners Wood Components
 Other _____
- What other companies do you purchase your tools and supplies from?

- Do you think your purchase represents good value?
 Yes No
- Would you recommend Grizzly Imports to a friend?
 Yes No
- Would you allow us to use your name as a reference for Grizzly customers in your area? **Note: We never use names more than three times.**
 Yes No
- Comments: _____

CUT ALONG DOTTED LINE

FOLD ALONG DOTTED LINE

Place
Stamp
Here



GRIZZLY INDUSTRIAL, INC.
P.O. BOX 2069
BELLINGHAM, WA 98227-2069

FOLD ALONG DOTTED LINE

Send a Grizzly Catalog to a friend:

Name _____
Street _____
City _____ State _____ Zip _____

TAPE ALONG EDGES--PLEASE DO NOT STAPLE