



DEEP FAT FRYER

MODEL

TMFE15, TMFE30

Installation and Operation Instructions

2M-Z13007 Rev. A March 15, 2012

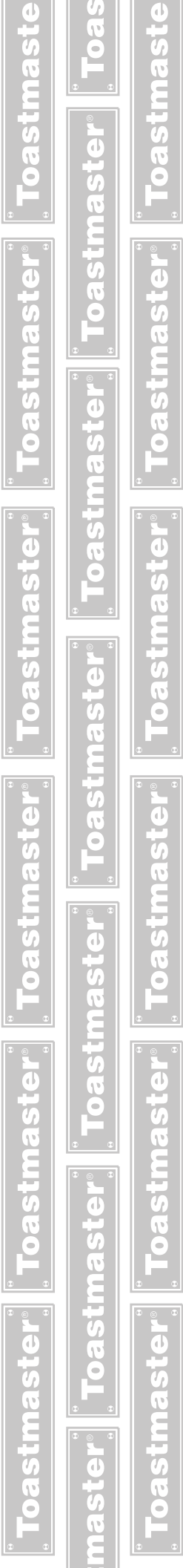

SAFETY SYMBOLS



These symbols are intended to alert the user to the presence of important operating and maintenance instructions in the manual accompanying the appliance.



RETAIN THIS MANUAL FOR FUTURE REFERENCE NOTICE

Using any part other than genuine Toastmaster factory supplied parts relieves the manufacturer of all liability.

Toastmaster reserves the right to change specifications and product design without notice. Such revisions do not entitle the buyer to corresponding changes, improvements, additions or replacements for previously purchased equipment.

Due to periodic changes in designs, methods, procedures, policies and regulations, the specifications contained in this sheet are subject to change without notice. While Toastmaster exercises good faith efforts to provide information that is accurate, we are not responsible for errors or omissions in information provided or conclusions reached as a result of using the specifications. By using the information provided, the user assumes all risks in connection with such use.

MAINTENANCE AND REPAIRS

Contact your local authorized service agent for service or required maintenance.

Please record the model number, serial number, voltage and purchase date in the area below and have it ready when you call to ensure a faster service.

Model No. _____
Serial No. _____
Voltage _____
Purchase Date _____

Authorized Service Agent Listing

Reference the listing provided with the unit

or

for an updated listing go to:

Website: www.toastmastercorp.com
E-mail Service@star-mfg.com
Telephone: (314) 678-6347

The Service Help Desk

Business Hours: 8:00 am to 4:30 p.m. Central Standard Time

Telephone: (800) 264-7827 Local (314) 678-6347

Fax: (800) 396-2677 Local (314) 781-2714

E-mail Parts@star-mfg.com
Service@star-mfg.com
Warranty@star-mfg.com

Website: www.star-mfg.com

Mailing Address: Toastmaster
10 Sunnen Drive
St. Louis, MO 63143
U.S.A



GENERAL INSTALLATION DATA

This equipment is designed and sold for commercial use only by personnel trained and experienced in its operation and is not sold for consumer use in and around the home nor for use directly by the general public in food service locations.

Before using your new equipment, read and understand all the instructions & labels associated with the unit prior to putting it into operation. Make sure all people associated with its use understand the units operation & safety before they use the unit.

All shipping containers should be checked for freight damage both visible and concealed. This unit has been tested and carefully packaged to insure delivery of your unit in perfect condition. If equipment is received in damaged condition, either apparent or concealed, a claim must be made with the delivering carrier.

Concealed damage or loss - if damage or loss is not apparent until after equipment is unpacked, a request for inspection of concealed damage must be made with carrier within 15 days. Be certain to retain all contents plus external and internal packaging materials for inspection. The carrier will make an inspection and will supply necessary claim forms.

WARNING: Improper installation, adjustment, alteration, service or maintenance can cause property damage, injury or death. Read the installation, operating and maintenance instructions thoroughly before installing or servicing the equipment.

This fryer is equipped for the voltage and wattage indicated on the nameplate mounted on the underside of the front edge. It is designed for use on alternating current (AC) only. It is intended for use by properly trained personnel only.



DO NOT CONNECT TO DIRECT CURRENT (DC)

The installation of the appliance should conform to:

NATIONAL ELECTRIC CODE AND ALL LOCAL ELECTRIC CODES AND ORDINANCES AND THE LOCAL ELECTRIC COMPANY RULES AND REGULATIONS

MODEL: TMFE15

Proper connections and power supply are essential for efficient performance. Connect six foot lead in cord to a suitable grounded outlet of the correct voltage. Be sure the switch is in the off position. The receptacle should match the plug (NEMA configuration of receptacle is: 6-30R).

MODEL: TMFE30

For your protection we recommend that a qualified electrician install this appliance. They should be familiar with electrical installations and all electrical codes. Proper connections and power supply are essential for efficient performance. The external wiring should be in conduit of an approved type of flexible cable suitable for operation at 194°F (90°C) and of a proper size to carry the load.

Four legs are provided and should be installed for ease of cleaning. Level unit by adjusting the (4) feet which have an adjustment of 1-3/8" (35 mm) for accurate leveling and perfect line-up with other units.

POWER SUPPLY

The Model TMFE15 & TMFE30 is wired at the factory for operation on a single phase power supply 208/240V, 60 Hz.



DO NOT INSTALL WITHOUT FEET.

PLACE THE LAMINATED WARNING SIGN SUPPLIED WITH THE FRYER IN AN AREA VISIBLE TO THE FRYER OPERATOR.

OPERATING INSTRUCTIONS

CLEAN KETTLE BEFORE USING

Take out baskets, push down and hold element catch, located on left side of element housing. Lift up on element lift handle until elements lock in a vertical position, and remove kettle. The kettle can be cleaned in a sink like any other pot or container.

ADDING FAT

Replace kettle and swing the element down by holding element lift handle and pushing release catch down and holding it there. Lower element. Fryer is now ready for use. Add fat. A fat level line on the rear of the kettle will guide you in determining the minimum cold fat level. A higher fat level can be used when frying bulky foods, such as chicken or fish cakes. The fat level should be chosen carefully so that the foaming action of the fat does not spill out of the kettle. If solid shortening is used, pack carefully around the elements. TMFE15 has one single 15lbs capacity kettle, TMFE30 has two.

CONTROLS

1. **ON/OFF TWO-POLE SWITCH** - Located on the front panel is a two-pole switch which turns power on or off.
2. **THERMOSTAT CONTROL** - Located on the Control Housing, this control allows you to select the desired frying temperature. A signal light indicates when the element is on. When the light goes off, the desired temperature has been reached.
3. **HI-LIMIT THERMOSTAT** - Should fat temperatures reach 450°F (230°C), this control will shut off the power. The light on the control panel will go out. The fat temperature must cool to 400°F (202.4°C) and the manual reset button located on the back panel of the control housing must be pressed to restore operation. Should the hi-limit control activate twice in succession, the primary thermostat should be checked for malfunction by a qualified service technician.

FRYING

After fat has been added, turn the switch on and set the thermostat at 200°F (92.4°C). After the fat has melted, turn the thermostat to the desired setting. Included in this instruction booklet is a frying chart and some helpful hints on fat use. After the selected fat temperature has been reached, the signal light goes out. Slowly lower half filled baskets into the fat. Do not overload baskets as this causes foods to be improperly fried. When moist food is lowered too quickly into hot fat, the fat will foam and spatter excessively.

NOTE: Baskets should be allowed to drain after frying cycle. The kettle handles serve as basket hangers.

IDLING

During idle periods turn thermostat control to approximately 200°F (92.4°C). The fast recovery fryers can be brought up to frying temperature in a matter of minutes. Lowering the temperature during idle periods saves energy costs and prolongs fat life. To turn off fryer turn the on/off switch to the "off" position.

DRAINING KETTLE

Turn switch to "OFF". Remove baskets. Raise element to the first stop and allow to drain. Raise the element to the vertical position and siphon the oil out of the kettle.

DO NOT ATTEMPT TO REMOVE THE KETTLE FILLED WITH HOT OIL. CONTACTING HOT OIL CAN RESULT IN SEVERE INJURIES OR DEATH.

If you do not have a siphon, order one from your dealer or dip the oil out and strain into a container. After oil has been removed, remove the kettle and clean.

CLEANING THE EXTERIOR

The exterior surfaces can be cleaned by regularly wiping with a soft cloth. Any discoloration can be removed with a non-abrasive cleaner.

MAINTENANCE AND REPAIRS

Contact the factory or one of its representatives or a local service company for service or maintenance if required.



CAUTIONS FOR ALL DEEP FAT FRYERS

NEVER LEAVE AN OPERATING FRYER UNATTENDED

REMEMBER HOT OIL IS DANGEROUS – RESPECT IT!



WARNING – INSTALLATION

- Locate your fryer in a protected place so that it cannot be tipped over or knocked off its support. A mechanical restraint should be installed to prohibit the fryer from tipping or moving. Consult your local codes for allowable methods of restraint.
- Install an automatic fire extinguisher over the fryer and in the exhaust duct.
- Be sure your power supply is installed properly and in accordance with the local and national codes.
- Install a shut-off switch or gas valve close to the fryer. It must turn off the fryer immediately.
- Failure to add a mechanical restraint can result in oil splashing out and contacting the skin, leading to serious injury or death!



WARNING – HOT OIL

- Hot oil is dangerous – Severe burns can result when hot oil contacts the skin.
- Hot oil is flammable – Keep open flames away from hot oil and its vapors.
- Never allow water or ice to get in hot oil.

IT CAN EXPLODE!



WARNING - ENVIRONMENT

- Keep your floors clean and free of grease and all other substances so no one slips accidentally and contacts the hot fryer.
- Keep areas and filters clean above your fryers – Oil soiled lint or dust can ignite easily and flames will spread rapidly.



WARNING – MAINTENANCE

- Have your equipment checked regularly to insure its safe and properly functioning.
- If your fryer starts to smoke or boil abnormally, cut off the power supply immediately and determine the reason for the smoking or boiling before attempting to use it again.



WARNING – TRAINING

- Train all personnel to understand the hazards of hot oil. Instruct them on the proper action to take if something does not seem to be acting properly.
- Instruct your personnel on what to do if there is an oil fire. Do not use water on an oil fire! Use only fire extinguishers of the approved type and never direct such extinguishers so as to blow the oil out of the oil container.
- Inappropriate use due to a lack of common sense may result in product damage or personal injury.

CARE OF FAT

In three to six months you may spend as much for fat as you paid for your kettle. So fat is an item you want to know all about; how to select it; how to manage it. The more production you can get from each pound of fat, the more profitable your frying operation will be.

To get a high rate of production per pound of fat you have to avoid two things. One is early breakdown and spoilage of the compound so that you have to throw it away before it does enough work to "earn its keep." The other is excessive sponging up of fat by the food being fried.

The main cause of fat breakdown is excessive heat. On the other hand abnormal absorption is caused by frying too long at too low temperatures. One answer to both problems is exact control of heat — so that fat neither smokes up nor soaks up.

Of course, no fat "keeps" forever. Not only heat, but air and moisture, salt particles and crumbs of food work to break it down. But you can slow up fat deterioration by maintaining proper temperatures and by draining your kettle, filtering or straining the fat once or twice a day and by keeping the kettle itself absolutely clean.

A number of commercial devices and materials are available to aid in eliminating fat impurities. There are several excellent models of pressure filters as well as strainer-type filters, which, if used regularly, will prolong life of fat.

However, no purification device will renew broken down or rancid fat or put new life into it. Once you have allowed fat to break down it becomes unsuitable for frying — in fact browning is impossible.

In addition to filtration, you can prolong the usefulness of fat by sweetening it with fresh compound every day - replacing about 15% of the bulk you started with. If you do enough frying so that normal absorption of fat in food amounts to 15% to 20% of the capacity of your kettle every day - then you can call that your turn-over food. It means you can add the recommended 15% of fresh fat without discarding any of the old.

10 POINT PROGRAM TO PRESERVE FAT AND PRODUCE THE FINEST FRIED FOODS

1. Choose a fat that does not break down quickly. Hydrogenated shortening, corn, and peanut oils are less likely to break down under high temperatures.
2. Do not fry foods at temperatures above those recommended. The higher the fat temperature, the more rapid the rate of fat deterioration. Above 400°F fats quickly deteriorate.
3. During short intervals between frying, turn the heat down. Do not keep heat on for long periods between batches.
4. Keep fat clean. Strain or filter daily or at end of each shift. Add at least 15% fresh fat to your kettle daily.
5. At least once a day, cool a small amount of fat and taste it to see if it has picked up foreign flavors.
6. Discard fat that tends to bubble excessively before food is added.
7. Do not overload baskets-pieces should not touch when frying. Shake baskets to prevent food from sticking together. Fry similar sizes together.
8. Never salt foods directly over fat, salt in fat reduces its life.
9. Raw, wet foods, such as potatoes and oysters, should be drained or wiped dry before frying to extend the life of the frying fat. Have foods to be fried at room temperature.
10. Keep fat temperatures below smoking point to minimize frying odors.

HANDY FRYING CHART

FOOD	COATING	PROCEDURE	TEMP	TIME IN MINUTES
POTATOES				
Standard French Fries		Cut in uniform pieces 1/2" square the long way	350°	5-7
Blanch Only			350°	3-1/2
Brown Only			350°	3-1/2
Long Branch		Cut in uniform pieces 3/4" square the long way	350°	7-10
Julienne (shoe string)		Cut in uniform pieces 1/8" to 1/4" square the long way	350°	3-6
Chips		Soak in cold running water until water does not run milky	350°	2-3
CHICKEN				
Large Pieces	Batter or	Some prefer rolling in	325°	9-11
Small Pieces	Breading	seasoned flour, dipping in egg wash, and frying	340°	7-10
Pre-cooked			350°	3-4
FISH				
Fillets (Large)	Breading	Select fillets of uniform size, skin out and dry.	350°	4
Fillets (Small)	or Batter		350°	3
Oysters	Breading or Batter	Use Oyster liquor in batter or breading	350°	5
Clams	Batter		350°	1
Scallops	Breading		350°	4
Shrimp	Batter	Some prefer soaking 1/2 hour in cold seasoned milk	350°	3
Smelts	Breading	Cut spinal cord several places to prevent curling	350°	4
MEATS				
Chicken Fried Steak	Breading	Sever all connecting membranes at one inch intervals to prevent curling	360°	3-4
Cutlets	Breading		350°	3-4
Chops	Breading		340°	3-4
Meat Balls	Breading or rolled in flour		340°	4-6
Brains	Breading		340°	3-5
VEGETABLES				
Asparagus	Batter or crumbs	Pre-cook in salted water	350°	3
Cauliflower	Batter or crumbs	Pre-cook and separate flowers	350°	3
Egg Plant	Crumb Breading	Peel, cut cross-wise into 1/4" slices	350°	3
Onions	Light batter	Slice thin, soak in milk for two hours	350°	3
FRITTERS				
Fruit (bananas, pineapples, apricots, berries)		Serve with fruit juice	350°	3-5
Corn	Batter	Serve with syrup or jelly	350°	3-5
Vegetable (peas, green beans)		Serve with tomato cheese sauce	350°	5-8
MISCELLANEOUS				
Croquettes	Breading		360°	3
Chinese Noodles			375°	1-2
French Toast			375°	1
DOUGHNUTS				
Cake			375°	1-1/2 - 2
Yeast, raised			375°	1

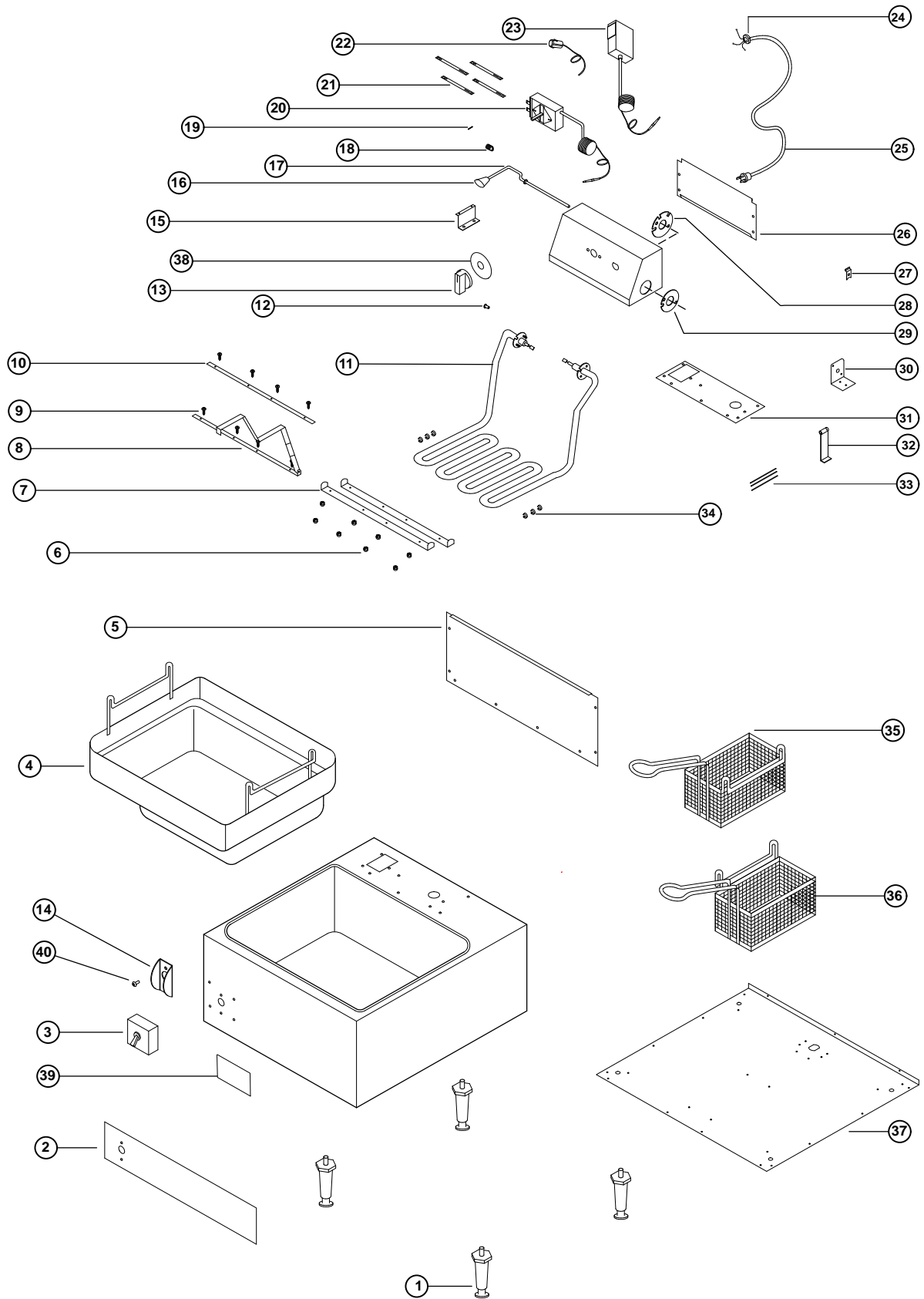

THIS DRAWING CONTAINS INFORMATION CONFIDENTIAL TO TOASTMASTER.
NO REPRODUCTION OR DISCLOSURE OF ITS CONTENTS IS PERMITTED.

MODEL: TMFE15
Electric Fryer



SK2434

Rev. A

3/15/12

PARTS LIST

March 15, 2012, Rev. A

Model: TMFE15, Electric Fryers			
Fig No	Part No	Qty	Description
1	2R-Y5092	4	BLACK PLASTIC LEG
2	2M-Z13007	1	FACEPLATE TMFE15
3	2E-Y5166	1	CIRCUIT BREAKER
4	2D-301007	1	KETTLE ASSEMBLY
5	E3-Y7254	1	PANEL-BACK
6	2C-2555	8	NUT-ACORN
7	E3-Y5940	2	LOWER ELEMENT CLAMP
8	E3-301043	1	HANDLE-CLAMP ASSEMBLY
9	2C-H1578	8	SCREW-8-32X1
10	E3-9280	1	CLAMP-ELEMENT
11	2N-Z2920	1	ELEMENT 5500 WATT
12	E3-9288	2	BUSHING-SPLIT
13	2R-Z13078	1	KNOB-ELEC FRYER
14	E1-Z1390	1	SWITCH GUARD
15	E3-Y7359	1	BRACKET-THERMO
16	2R-9572	1	KNOB-HARRY DAVIE
17	E3-301060-PS	1	RELEASE ROD/PAWL KIT
18	2P-9274	1	SPRING-RELEASE
19	2A-Y1105	2	PIN ROLL
20	2T-Z7268	1	THERMOSTAT
21	E1-7363	4	CLAMP-THERMOSTAT
22	E3-301059	1	PILOT-LIGHT ASSEMBLY
23	2T-Z3209	1	THERMOSTAT-SAFETY
24	2K-Y6764	1	BUSHING-STRAIN
25	E3-301044	1	CORD-ASSEMBLY NEMA 6-30P
26	E3-9262	1	BACK-ELEMENT HOUSING
27	E3-Y1621	1	CLIP-GROUND
28	E3-9270	3	PLATE-ELEMENT SUPPORT
29	E3-9269	4	BEARING, PIVOT
30	E3-7674	2	ANGLE-CAPILLARY
31	2I-9277	1	GASKET
32	E3-9276	1	ARM-PAWL
33	2P-Y3453	4	WIRE-SPACER
34	2P-5737	6	CLIP-CAPILLARY
35	2B-301042	1	BASKET, RIGHT
36	2B-301041	1	BASKET, LEFT
37	E3-301046	1	BOTTOM ASSEMBLY
38	2M-Z7219	1	SIGN-STICKER
39	2M-Z8942	1	LABEL-FRYER BURN WARNING
40	2C-Z4341	2	SCREW, #6-32 X 1/4 RHPH
NI	2M-Z8943	1	WALL SIGN-FRYER WARNINGS

**IMPORTANT: WHEN ORDERING, SPECIFY VOLTAGE OR TYPE GAS DESIRED
INCLUDE MODEL AND SERIAL NUMBER**

PAGE 1
OF 1

Some items are included for illustrative purposes only and in certain instances may not be available.

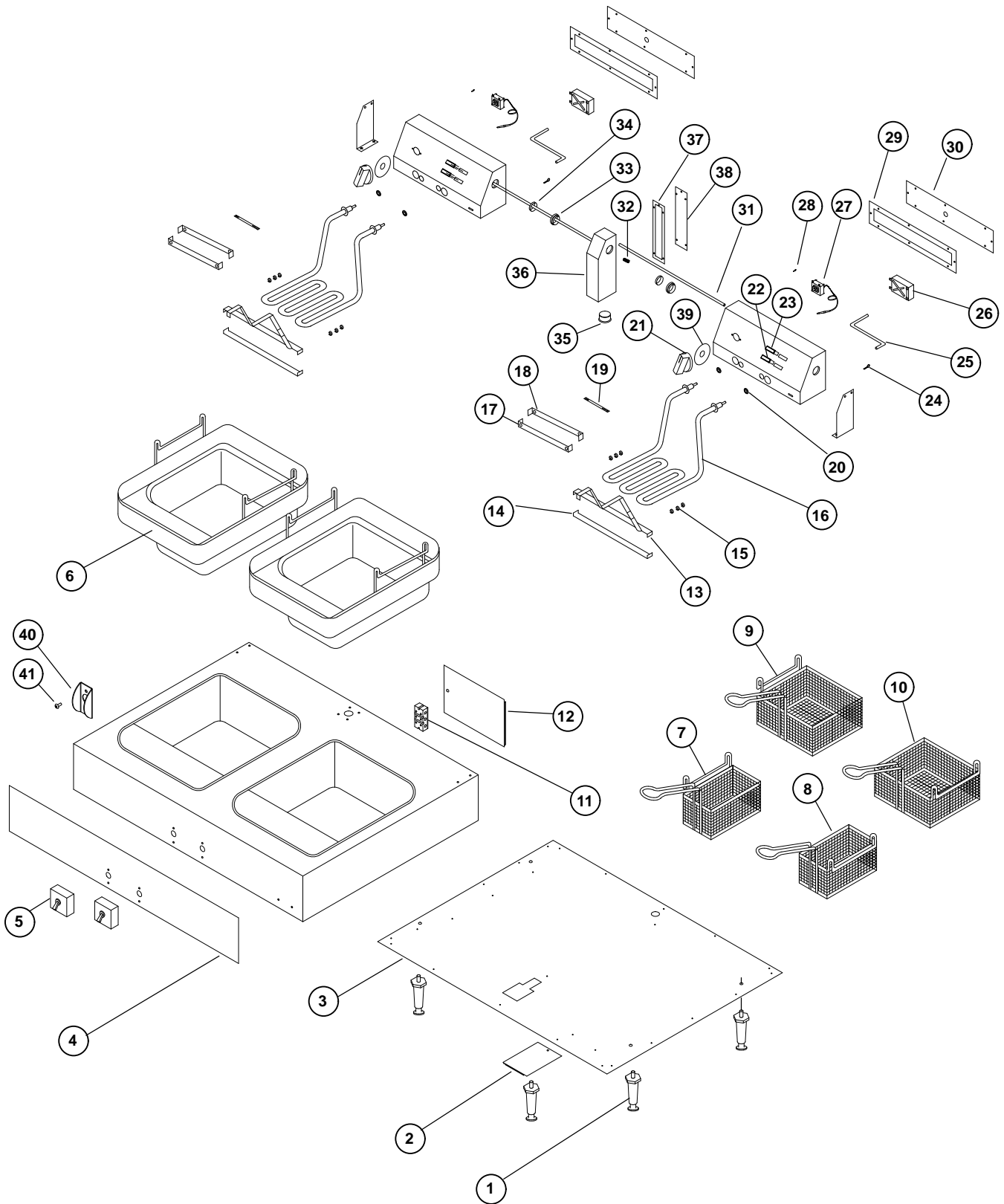

MODEL: TMFE30
Electric Fryer



SK2442

Rev. A

3/15/12

PARTS LIST

March 15, 2012, Rev. A

Model: TMFE30, Electric Fryers			
Fig No	Part No	Qty	Description
1	2R-Y5092	4	BLACK PLASTIC LEG
2	E1-Y5083	1	PANEL, INSPECTION, SMALL
3	E8-Z13102	1	BOTTOM ASSEMBLY
4	2M-Z13098	1	FACEPLATE
5	2E-Y5166	2	SWITCH - 2 POLE 30 AMP
6	E1-115714	2	KETTLE ASSEMBLY, COMPLETE
7	2B-115774	2	BASKET - TWIN, LEFT HANGER (OPTIONAL)
8	2B-115775	2	BASKET - TWIN, RIGHT HANGER (OPTIONAL)
9	2B-Y8847	1	BASKET - HANGER LT
10	2B-Y8846	1	BASKET - HANGER RT
11	2E-Y2849	1	TERMINAL BLOCK
12	E1-Y5084	1	PANEL, INSPECTION
13	E1-115719	2	ELEMENT HANDLE ASSEMBLY
14	E1-Y1669	2	UPPER ELEMENT CLAMP
15	2P-5737	12	CLIP - CAPILLARY TUBE
16	2N-Y5168	2	ELEMENT 240V, 5750W
17	E1-Y1889	2	BRACE - ELEMENT (LONG)
18	E1-Y1890	2	BRACE - ELEMENT (SHORT)
19	E1-7363	2	CLAMP - THERMOSTAT BULB
20	2I-5659	4	GROMMET - CAPILLARY TUBE
21	2R-Z13100	2	KNOB - THERMOSTAT
22	E1-116314	2	SIGNAL LIGHT - POWER ON (WHITE)
23	E1-116313	2	SIGNAL LIGHT - HEATING (AMBER)
24	2A-5401	2	PIN - COTTER (3/4")
25	E1-Y5108	2	ROD - CATCH RELEASE
26	2T-Z7208	2	THERMOSTAT
27	2T-Y1668	2	SAFETY THERMOSTAT
28	2A-7435	2	PIN - COTTER (3/8")
29	2I-Y5097	2	GASKET - ELEMENT HOUSING
30	E1-Y5286	2	BACK - ELEMENT HOUSING
31	E1-Y5109	2	ROD - CATCH
32	2P-7969	2	SPRING
33	E1-Y5090	2	PIVOT BUSHING
34	2I-Y5088	2	GASKET - PIVOT
35	2K-Y5093	1	BUSHING - 1"
36	E1-515005	1	WIRE HOUSING ASSEMBLY
37	2I-Y5095	1	GASKET - WIRE HOUSING
38	E1-Y5086	1	BACK - WIRE HOUSING
39	2M-Z7219	2	SIGN - LABEL, TEMP SETTINGS
40	E1-Z1390	1	SWITCH GUARD
41	2C-Z4341	2	SCREW, #6-32 X 1/4 RHPH
NI	2M-Z8942	1	LABEL-FRYER BURN WARNING
NI	2M-Z8943	1	SIGN-FRYER WARNINGS
NI	2M-Y2089	1	LABEL-RESET
NI	2M-Y5135	1	LABEL WIRING DIAGRAM
NI	2P-Y3406	2	WIRE SPACER, THERMOSTAT BULB - .302 DIA.
NI	2P-Y3453	2	WIRE SPACER, SAFTEY THERMO BULB - .350 DIA.

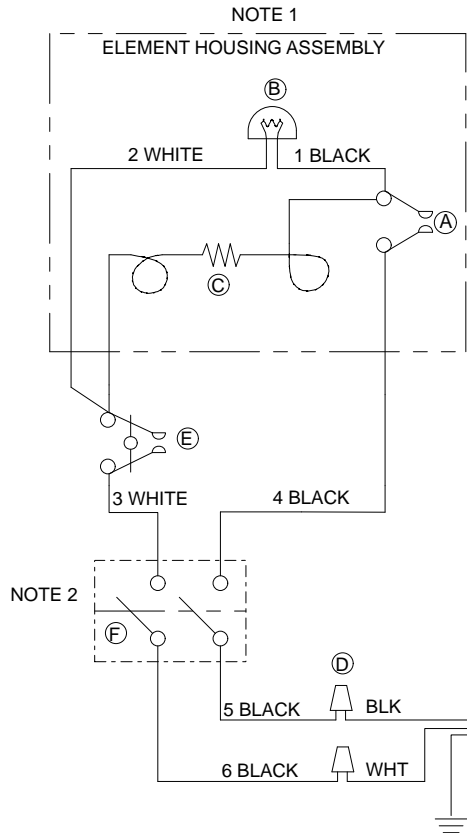

- NOTES:
1. LOOKING TOWARDS REAR OF ELEMENT CONTROL ASSEMBLY.
 2. LOOKING TOWARDS REAR OF THE SWITCH.
- (A) THERMOSTAT
 - (B) PILOT LIGHT
 - (C) HEATING ELEMENT
 - (D) WIRE NUT (2)
 - (E) HIGH LIMIT THERMOSTAT
 - (F) ON-OFF SWITCH (2 POLE)

NOTE: ALL POWER WIRES ARE #12 GAUGE
 NEMA PLUG NUMBER 6-30P
 CORD:12AWG/3,SJTO 105 C,250V
 CORDSET ASSY# E3-301044

RATED WATTAGE	SINGLE PHASE	NOMINAL AMPS
4130	208V	19.9
5500	240V	22.9

MODEL: TMFE15

THIS DRAWING CONTAINS INFORMATION CONFIDENTIAL TO STAR MFG. INT'L. INC.
 NO REPRODUCTION OR DISCLOSURE OF ITS CONTENTS IS PERMITTED.



SK1724-1 Rev C 9/1/2009

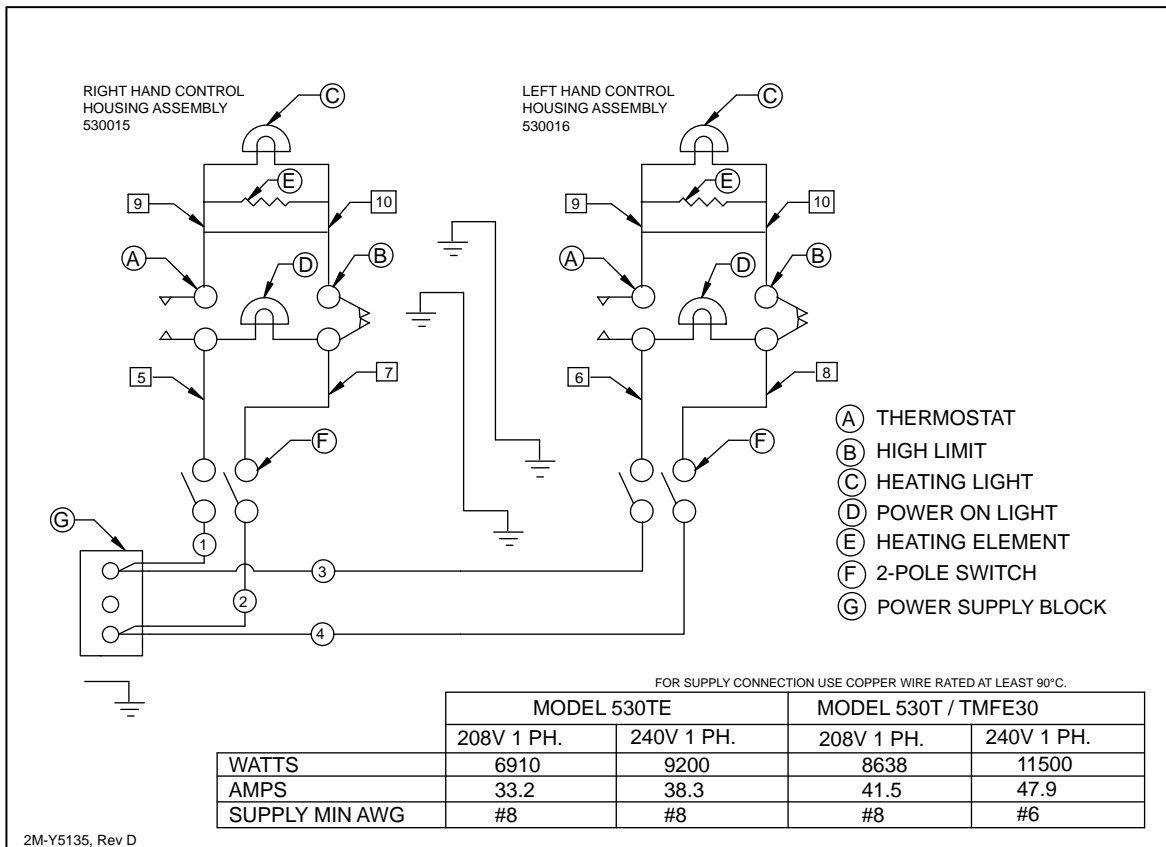

MODEL: TMFE30



Warranty Statement

This warranty is effective on all Toaster equipment sold on or after July 1, 2006, and supersedes all previous warranties.

Toaster warrants equipment that it manufactures to be free from defects in material and workmanship. Toaster's obligation is limited to repairing or replacing, at Toaster's option, without cost to the customer, any part found to be defective, as well as any labor or material expense required to replace the part.

Length of Warranty

This warranty is effective for a period of 12 months from the date the equipment is placed in service. Models that are considered portable should be taken to the closest Toaster service agency, transportation prepaid.

Exceptions

- This warranty is valid only for the original end user owner/operator of the equipment.
- This warranty does not apply to normal maintenance functions, including (but not limited to) improper operation, installation or the use of an improper utility supply.
- This warranty is valid only if the equipment is used in a commercial setting. The equipment is designed and constructed for commercial use by trained professionals only. Any use of the equipment in private or domestic applications immediately voids this warranty.
- This warranty does not apply to any parts, labor and material expenses for service that is not pre-approved and performed by a Toaster authorized service agent. Any such service immediately voids this warranty.
- This warranty does not apply to any parts, labor and material expenses associated with the installation of parts that are not factory-approved for use in the equipment. Any use of such parts immediately voids this warranty.
- This warranty is not valid if terms of payment have not been met.
- Portable units is a unit that's designed to sit on a countertop, has a powercord & is less than 50lbs installed.

Toaster reserves the right to change the design and specifications of this equipment or any related documentation at any time. The end user is not entitled to upgrades resulting from these changes.

This warranty is exclusive and supersedes all other warranties for the equipment, both expressed and implied. There are no implied warranties of merchantability or of fitness for a particular purpose.

The foregoing is Toaster's sole and exclusive obligation and the end user sole and exclusive remedy for any action including breach of contract or negligence. In no event shall Toaster be liable for a sum in excess of the purchase price of the equipment, or for any prospective or lost profits of the end user.