

AUTOMATIC STEREO TURNTABLE SYSTEM

PS-X6

PS-X7



Owner's instruction manual

Before operating your new Sony turntable, please read this manual completely to become familiar with all its features and capabilities.

Keep this manual handy for future reference.

This instruction manual covers both the PS-X6 and the PS-X7, which differ only in the arm pipe, shell and rubber mat. There are no differences in their operation.

OWNER'S RECORD

The model and serial numbers are located at the rear. Record these numbers in the spaces provided below. Refer to them whenever you call upon your Sony dealer regarding this product.

Model No. PS-X6,X7

Serial No. _____

TABLE OF CONTENTS

Features	3
Warning	3
Precautions	3
Notes on installation	3
Parts identification	4
Turntable assembly	4
Cartridge installation	5
Tonearm assembly and adjustment	6
Connections	8
Record playing	8
Tips on record handling	9
Tonearm drop-point adjustment	10
Maintenance	10
Repacking for shipment	10
Specifications	11
Trouble checks	11

FEATURES

PS-X6, PS-X7 FEATURES

- Automatic turntable—auto start, auto stop, auto return, and auto repeat functions are activated by merely touching the logic controlled START/STOP switch and the REPEAT switch.
- The Crystal Lock System maintains the turntable at an accurate nominal speed under voltage or temperature variations or aging, and shows excellent initial drift and load/speed characteristics.
- With a newly developed BSL (brushless and slotless) Motor having a torque of 1 kg-cm, excellent starting characteristics within a third revolution at 33 1/3 are obtained.
- A servo system, which consists of a turntable with a magnet coated rim and an 8-pole magnetic pick-up head, and the BSL Motor free from torque irregularity, assure minimal wow and flutter and a high signal-to-noise ratio. The turntable attains nominal speed almost immediately after changing from 33 1/3 rpm to 45 rpm or vice versa.
- Luminous Sensor (photoelectric circuit) is employed for a smooth arm return, which eliminates mechanical force on the cartridge or tonearm.
- The automatic operation system is designed so as not to affect the tonearm if you accidentally touch it while it is moving in the auto start or auto return mode, or in case you change the record size selector position during an operation mode.
- Acoustic material SBMC (Sony Bulk Mold Compound) is used in the constructions of the frame, to reduce outside vibration effects to a minimum.
- Newly developed resilient feet effectively prevent acoustic feedback.

ADDITIONAL PS-X7 FEATURE

- An arm pipe made of carbon fiber suppresses resonance interference.
- Fluid-filled rubber mat absorbs any disc vibration.

WARNING

- To prevent fire or shock hazard, do not expose the unit to rain or moisture.
- To avoid electrical shock, do not open the cabinet. Refer servicing to qualified personnel only.

PRECAUTIONS

- Check that the operating voltage for your unit is identical with that of your local power supply.
- Should any liquid or solid object fall into the cabinet, unplug the unit and have it checked by qualified personnel before operating it any further.
- Unplug the unit from the wall outlet if it is not to be used for an extended period of time. To disconnect the cord, pull it out by grasping the plug. Never pull it out by the cord.

NOTES ON INSTALLATION

- Place the turntable on a level surface.
- Avoid placing the unit near electrical appliances (such as a television, hair dryer, or fluorescent lamp) which may cause hum or noise.
- Avoid any vibration such as from speakers, slamming of doors, etc.
- Keep the unit away from direct sunlight, extremes of temperature, or excessive dust and moisture.
- Allow 10 cm (4 inches) clearance behind the unit so that the cover can be opened.

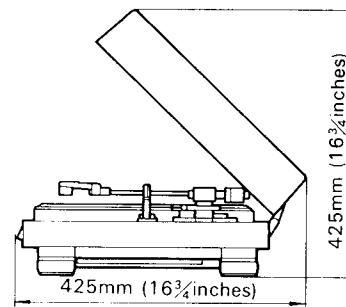

- The turntable has resilient feet that isolate the mechanism from external shock and vibration. Use them in locked position, but when placing the turntable on an uneven surface, turn each foot counterclockwise until the unit is level. Be sure not to pinch or remove the rubber.

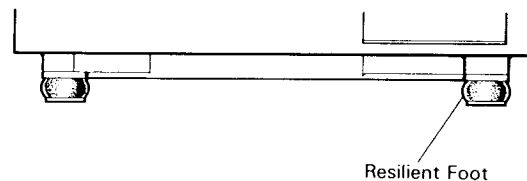

PARTS IDENTIFICATION

The picture below shows the appearance of the assembled turntable.

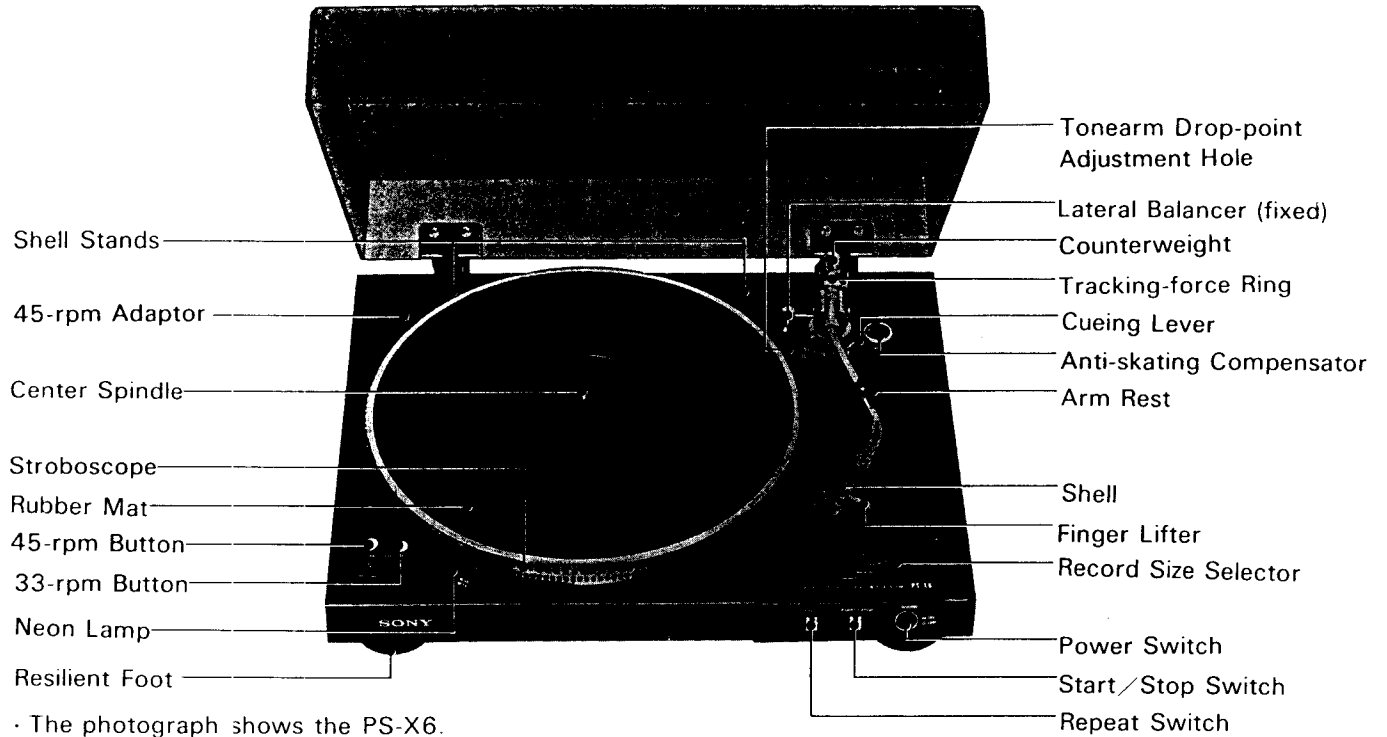

TURNTABLE ASSEMBLY

Do not connect the power cord or the connecting cords until after finishing the assembly.
Remove all packing material and clean the cabinet.

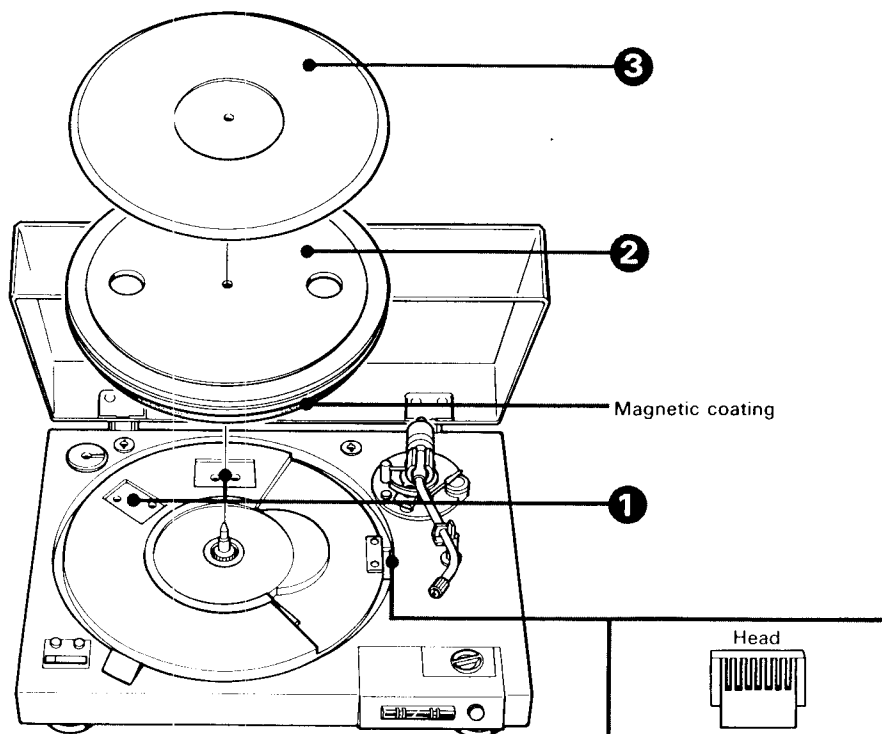

CARTRIDGE INSTALLATION

❶ Remove the red-painted transit screws. Store them in the holes on the label. (These screws will be required when repacking.)

❷ Carefully place the platter on the motor board by matching the center hole and the center spindle.

● Do not touch the magnetic coating with your fingers or damage the magnetic pick-up head.

❸ Place the rubber mat on the platter.

● When handling the rubber mat of the PS-X7, take care not to bend it. If the surface of the mat is not level, place it on a level surface until it becomes level.

To remove the dust cover

Open the dust cover fully and slide it as illustrated while holding it with both hands.

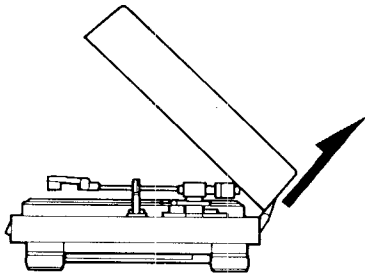

A cartridge weighing between 2.5 and 9.5 g can be mounted with the supplied shell. Heavier cartridges from 8 to 14.5 g can be mounted using the extra weight (supplied).

❶ Select the most suitable length of cartridge mounting screws according to the height of your cartridge. (Three pairs of screws of various lengths are supplied.)

❷ Install the cartridge into the shell with the supplied mounting screws so that the distance between the shell end and the stylus tip is 49 mm (1 15/16 inches). The temporary overhang adjustment is then complete. More precise adjustment should be made later.

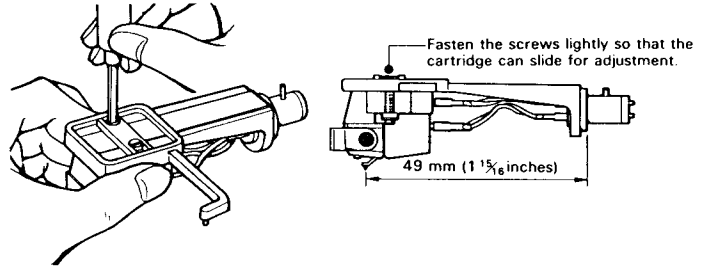

❸ Connect the lead wires of the shell to the corresponding pins on the cartridge.

Wires	Cartridge pins
White	L (left channel signal)
Blue	LE or G (left channel ground)
Red	R (right channel signal)
Green	RE or G (right channel ground)

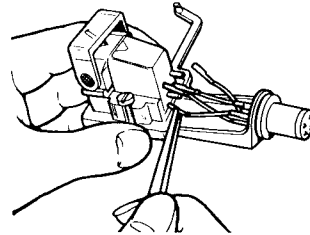

● Shell stands are provided on the base of the turntable for extra mounted cartridges.

TONARM ASSEMBLY AND ADJUSTMENT

The following procedures should be performed on a level surface. Be careful not to damage the stylus tip while making adjustments.

When a cartridge is replaced, readjustments are required.

Preparation

- 1 Secure the Tonearm to the Arm Rest and lower the Cueing Lever.
- 2 Plug the Shell into the Tonearm and turn the Locking Collar counterclockwise until the Shell is firmly locked.
- 3 Insert and turn the Counterweight counterclockwise several turns. (The Tracking-force Ring turns simultaneously.)
- 4 Remove the stylus guard, if fitted.

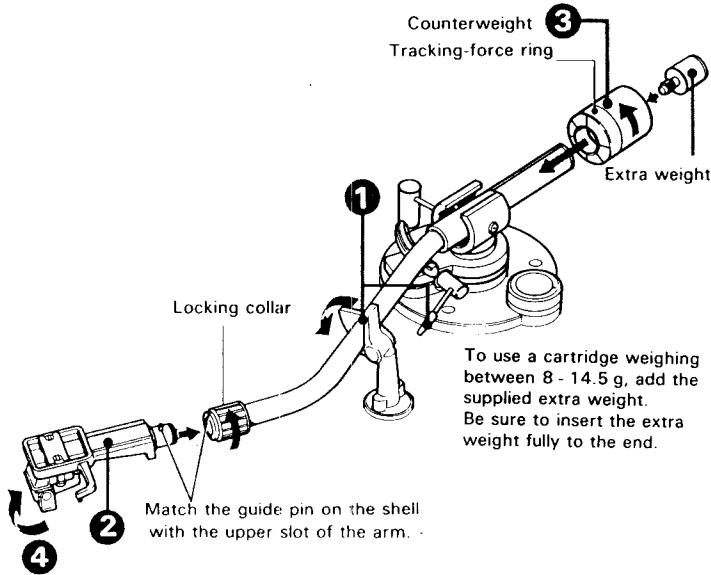

Longitudinal balance adjustment *1

For this adjustment, connect the power cord and turn on the POWER Switch.

- 1 Set the Record Size Selector to the MANUAL position.
- 2 Touch the START/STOP Switch. The turntable will start rotating. After several rotations of the turntable, turn off the POWER Switch and at the same time stop the turntable by hand; do not turn off the START/STOP Switch. This will cause the Tonearm Platform to lower and permit a more positive longitudinal balance adjustment.
- 3 Be sure that the Anti-skating Compensator is set at "0".
- 4 Release the Tonearm from the Arm Rest and set the Arm Rest as illustrated.

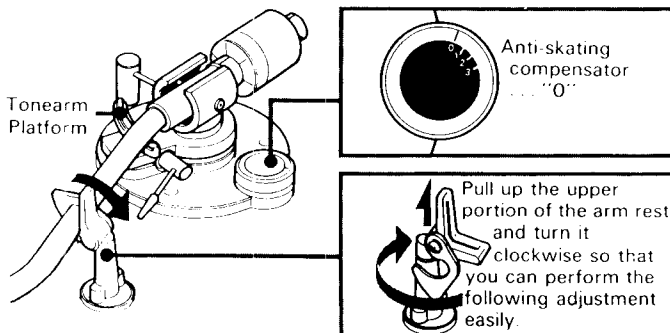

- 5 Turn the Counterweight as required until the Tonearm is in a horizontally balanced position. (The Tracking-force Ring turns simultaneously.)

Release your fingers and check the balance. Repeat this step until the arm balances.

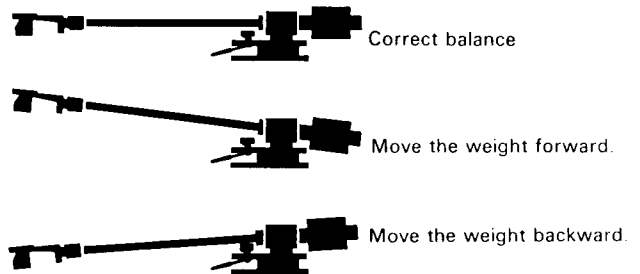
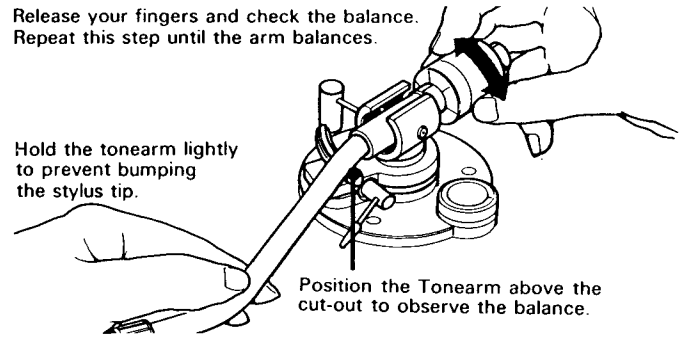

- 6 While holding the Counterweight at the balanced position, separately turn the Tracking-force Ring until the "0" indication meets the center line on the Tonearm. Recheck the balance.

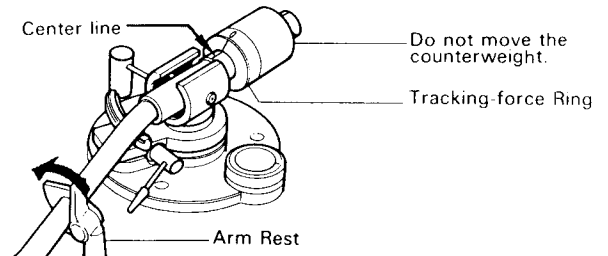

- 7 Pull up the Arm Rest and turn it counterclockwise so that the Arm Rest returns to its original position. Secure the Tonearm to the Arm Rest again.

Tracking-force adjustment *2

Turn the Counterweight counterclockwise so that the recommended tracking-force figure for your cartridge is aligned with the center line on the Tonearm. The maximum tracking force available is 3 grams.

Tracking-force ring will turn at the same time.

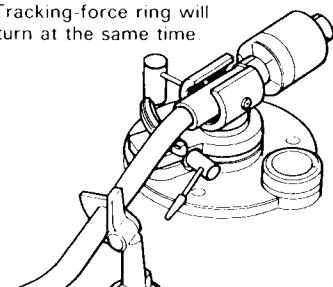

Overhang check *3

Check that the stylus overhang is set correctly by using the Alignment Protractor supplied. Be sure that the Record Size Selector is set at MANUAL position.

❶ Place the hole of the Alignment Protractor over the Center Spindle.

❷ Release the clasp of the Arm Rest and lift up the Cueing Lever. The Tonearm Platform will rise.

❸ Bring the Tonearm above the cross point of the two fine lines, and carefully lower the stylus on the cross point with the Cueing Lever.

❹ Check to see that the Shell is parallel to the thick lines drawn on the Alignment Protractor as shown in the center illustration. If they are parallel, the stylus overhang is set correctly.

❺ If the Shell is not parallel, readjust the stylus overhang.

1) Loosen the cartridge mounting screws and slide the cartridge in the required direction.

2) Re-tighten the screws.

3) Recheck the balance and tracking-force adjustments.

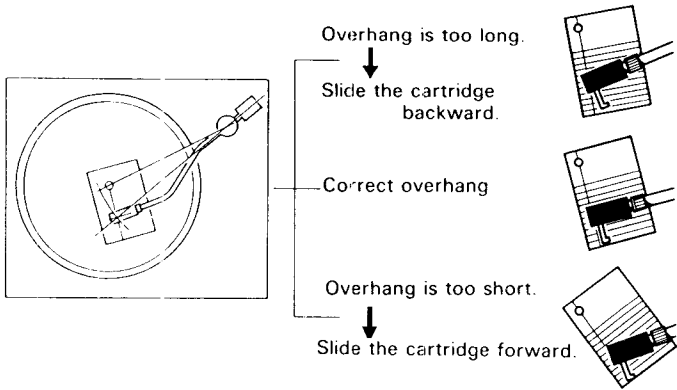

After the adjustments are complete, install the stylus guard.

Anti-skating compensation *4

Turn the Anti-skating Compensator so that the guide mark is aligned with the tracking-force value used.

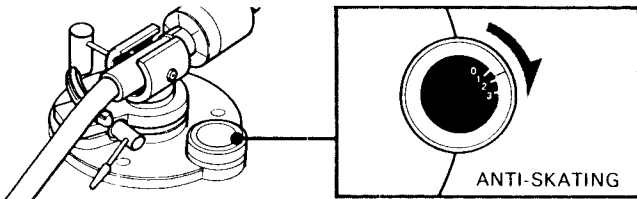

Lateral balance adjustment *5

This is fixed, and requires no adjustment.

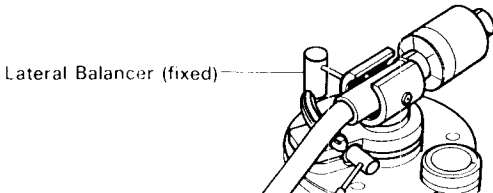

After the tonearm adjustments

When the Tonearm adjustments are completed, push the POWER Switch again and touch the START/STOP Switch to stop the turntable rotation. This will cause the Tonearm Platform to rise and be ready for record playing.

*1 Longitudinal balance adjustment

While playing the record, the weight of the tonearm is supported by the arm pivot and only tracking force is applied to the stylus tip. To accomplish this, the tonearm must first be balanced horizontally, with the tracking force indicator set at "0".

*2 Tracking force

After the longitudinal balance adjustment, apply the recommended tracking force weight so that the stylus tip will trace the music groove accurately.

*3 Overhang

In record playing, because of the pivoted design of the tonearm, the stylus tip can be perfectly tangent to the music groove at only one point of the record. At all other portions of the record, there is a slight deviation of the stylus from tangency. This is called the tracking error, and introduces minute errors in the amplitude and timing of the reproduced signal as compared to the original, and other forms of distortion which may be introduced depending on the cartridge and stylus design.

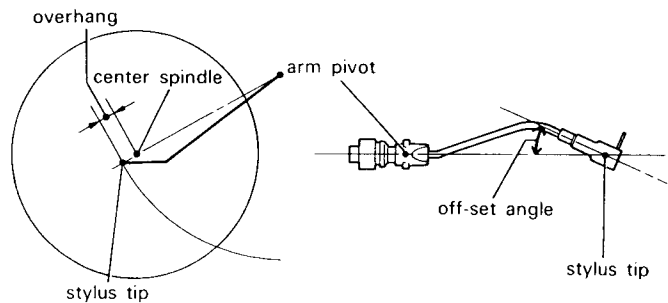

Tracking error is minimized by the selection of an optimum "off-set" angle and "overhang" distance. Overhang is the distance between the stylus tip and the center spindle. This overhang adjustment is made at the time of installing a particular cartridge, while the off-set angle is fixed by the manufacturer of the tonearm.

*4 Anti-skating compensation

While the record is being played, the frictional force between the record groove and the stylus produces a force that tends to drive the tonearm toward the center of the record. The anti-skating compensation cancels the above mentioned force, and is applied in accordance with the tracking force.

Incorrect anti-skating compensation results in sound distortion and uneven wear on both the stylus and the record.

*5 Lateral balance

A lateral balancer (fixed) is provided to prevent the tonearm from moving inward or outward.

CONNECTIONS

- When connecting to an accessory ac outlet on the amplifier use an unswitched type outlet.
- Check that the phono cord and power cord are not caught under any foot of the cabinet.
- Leave a little slack in the connecting cord to allow for inadvertent shock or vibration.

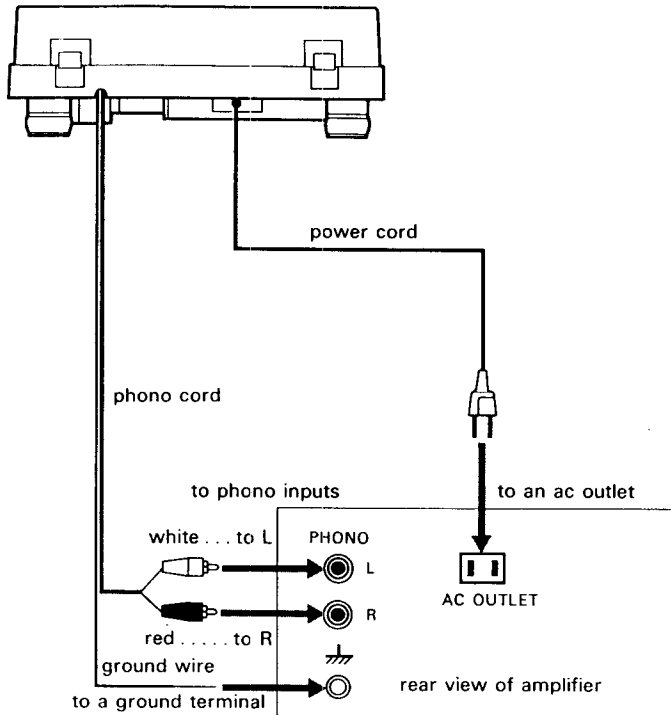

RECORD PLAYING

AUTOMATIC PLAYING

Amplifier setting

- Lower the amplifier volume and set the input selector to PHONO. Turn on the amplifier.
- After the Tonearm has lowered onto the record, adjust the volume and tone of the amplifier.

Player Setting

- 1 Perform the following preparatory steps.

Place a record.

- For 17cm (7-inch) records, put the supplied 45-rpm adaptor over the center spindle.

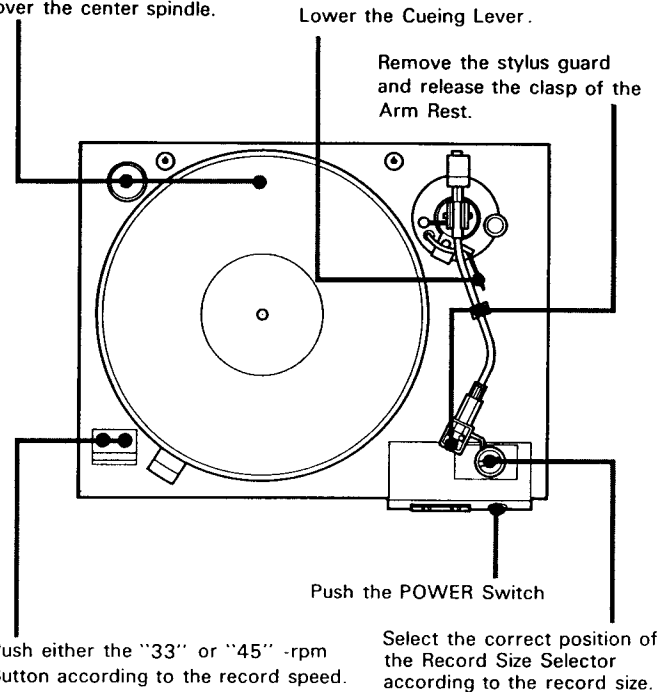

- 2 Touch the two metallic strips of the START/STOP Switch. The Lamp will illuminate and play will begin automatically. When the Tonearm reaches the end of the record, it will automatically rise and return to the Arm Rest, and the turntable will stop.

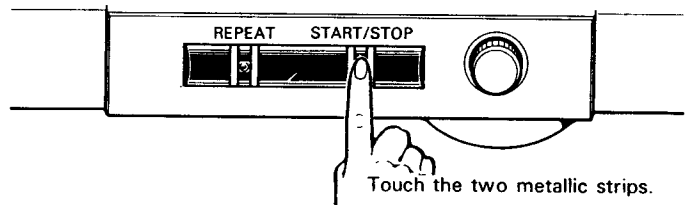

NOTES

- Turn off the POWER Switch after the Tonearm returns fully to the Arm Rest. If the POWER Switch is turned off while the Tonearm is still moving in the return operation, the unit may not start correctly the next time.
- Be sure to secure the Tonearm to the Arm Rest with the clasp when not in use. This insures that the safety device will function to prevent the Tonearm from moving if you mistakenly touch the START/STOP Switch with no record on the platter.

● If the Lamp goes out just after touching the START/STOP Switch to start the Tonearm, it indicates that the unit had been in the return mode when the power was cut off. In this case, touch the START/STOP Switch again, and the Lamp will light up and the Tonearm will start.

TO STOP DURING PLAY

Touch the START/STOP Switch. The Start Lamp will go out, and the Tonearm will return to the Arm Rest.

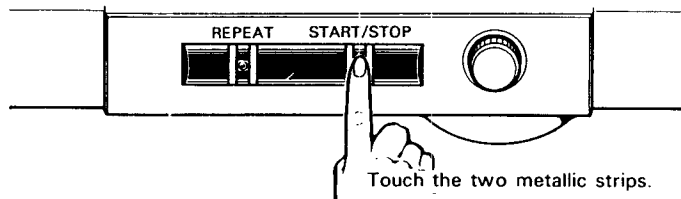

REPEAT PLAYING

Touch the START/STOP Switch and then the REPEAT Switch. The Repeat Lamp will illuminate and the unit will repeat the same record.

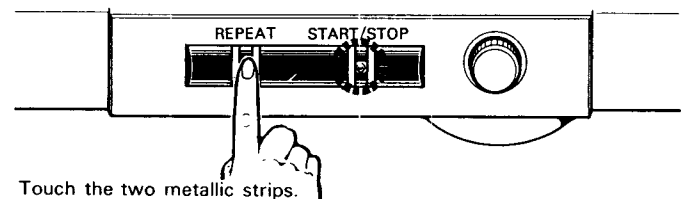

To stop repeat playing, touch the REPEAT Switch again. The Repeat Lamp will go out, and after the record is played, the Tonearm will return to the Arm Rest.

MANUAL PLAYING (TO START PLAYING PART-WAY ON THE RECORD)

Perform the preparatory steps, except that for the Record Size Selector setting, as shown in step ① under "Automatic playing". Then continue with the following steps:

- ① Set the Record Size Selector to the MANUAL position.
- ② Bring the Tonearm to the position you desire over the record.
- ③ Touch the START/STOP Switch. The turntable will start rotating, the Tonearm will lower itself, and play will begin. When the Tonearm reaches the end of the record, it will automatically rise and return to the Arm Rest, and the turntable will stop.

NOTES

● If you touch the REPEAT Switch in manual playing, the Repeat Lamp will illuminate but the repeat function will not operate. After playing, the Tonearm will return automatically to the Arm Rest, but the turntable will continue rotating. In this case, touch the START/STOP Switch to stop the turntable.

● If you bring the Tonearm too near the label of the record while the turntable is rotating, the Tonearm may return to the Arm Rest as a result of having activated the automatic return mechanism.

CUEING LEVER

Usually, keep the lever lowered. To lift up the stylus or to change the listening point during playing, lift the Cueing Lever up. The Tonearm will rise. To start playing again, lower the Cueing Lever toward you.

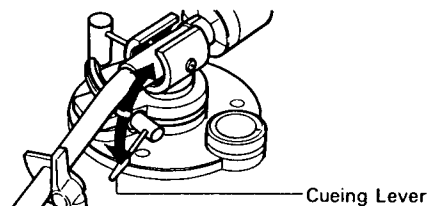

STROBOSCOPE AND NEON LAMP

The Crystal Lock System assures precise turntable speed. This is verified by viewing the neon lamp stroboscope pattern, which will appear stationary at the correct speed. The upper line is for 45 rpm and the lower for 33 1/3 rpm.

● Always view the stroboscope with the light of the neon lamp provided, not with the light of a fluorescent lamp. This is because the neon lamp is energized by a 120-Hz pulse from the built-in crystal oscillator and assures precise speed indication regardless of any line-frequency deviation.

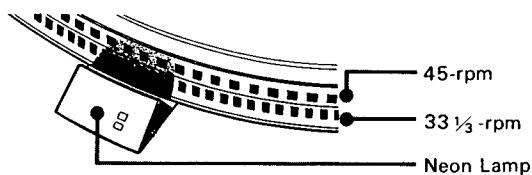

TIPS ON RECORD HANDLING

Before playing

- Clean the stylus, using a soft brush (stylus brush, artist's paint brush, etc). Brush the stylus from back to front. Never attempt to clean the stylus with your finger tip.
- For routine cleaning of records, the use of a barely damp soft cloth (gauze, etc.) or a fluid type cleaner will be effective. If a spray type record cleaner is used, make sure that the cleaner has dried completely before playing the records. Playing the record before the fluid has dried may damage the record. It is a good idea to clean the record again before putting it away.
- Handle a record by its edges and don't touch the music grooves. Finger prints on the record surface may induce an accumulation of dust, resulting in impaired tone.

MAINTENANCE

When record playing

- It is recommended that you reduce the amplifier volume before you lower the tonearm onto the record.
- While the turntable is energized, don't attempt to stop or reverse the turntable by hand.
- During play, be sure to close the dust cover. Don't place anything on the dust cover.
- While playing, never attempt to move the turntable or touch the tonearm.

After playing

- Avoid exposing records to any source of heat, such as direct sunlight, a hot-air duct, etc. Store records vertically without applying any pressure or inclining to either side. This will minimize any warpage.
- When not using the turntable, close the dust cover.

Other precautions

- Don't put anything but records on a turntable.
- Don't place anything but the spare cartridges and 45-rpm adaptor on the turntable deck.

- Clean the cabinet and dust cover periodically with a soft dry cloth. Do not use solvents such as alcohol, benzine or thinner, since they will damage the finish.
- When the rubber mat becomes dirty, wipe it gently with a soft cloth slightly dampened with water.
- No lubrication is required for this turntable. The motor shaft is factory lubricated for the life of the turntable.

REPACKING FOR SHIPMENT

The original shipping carton and packing material (which we asked you to save) is the ideal container for use in shipping the unit for repair work, or to another location. To secure the maximum protection, it must be repacked in this material precisely as before. The proper repacking procedure is shown in the illustration.

- Clip the tonearm to the arm rest and bind it there with a tape.
- Fasten the transit screws in their original position by referring to the illustration of "TURNTABLE ASSEMBLY" to secure the inside parts to the cabinet. Turn the screws fully clockwise.

TONEARM DROP-POINT ADJUSTMENT

At the factory, the tonearm has been adjusted to have the correct drop point in the automatic playing mode. If this needs to be readjusted, proceed as follows.

- 1 Remove the rubber cap of the tonearm drop-point adjustment hole located at the left side of the arm base.

- 2 Insert the supplied screwdriver into the hole.

To change the drop point inward . . . Turn the screw slightly counterclockwise.

To change the drop-point outward . . . Turn the screw slightly clockwise.

- Once it is properly adjusted with a 30 cm (12") record, the drop point will be correct for 17 cm (7") and 25 cm (10") records as well.

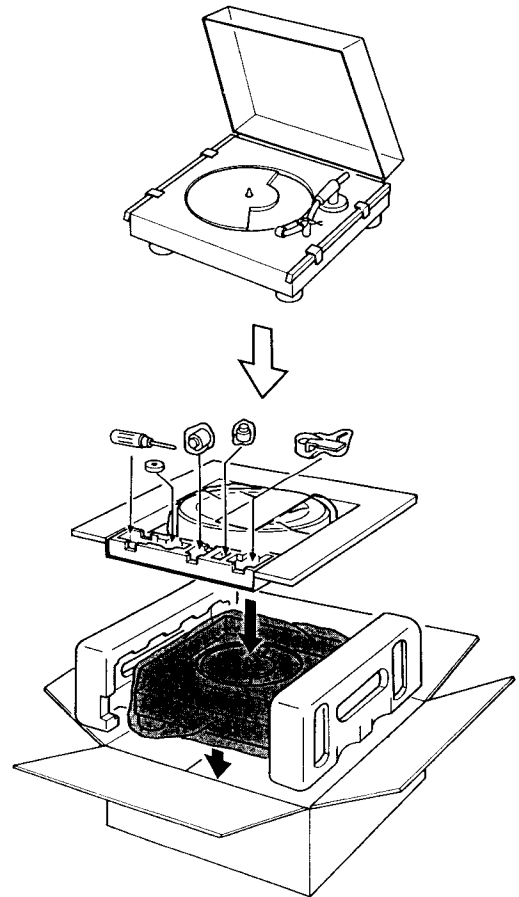
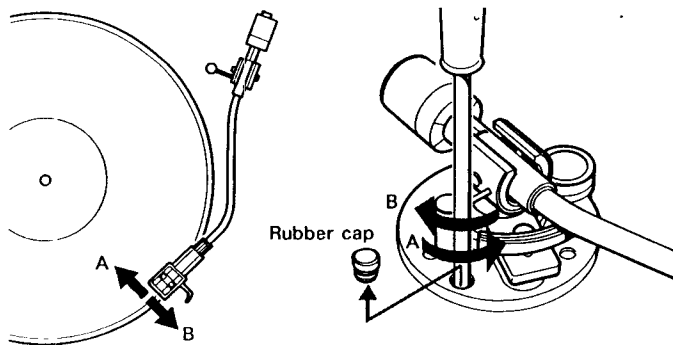

SPECIFICATIONS

Turntable	Automatic player
Platter	31.7 cm (12 1/2"), aluminum-alloy diecast
Motor	DC servo-controlled motor (brushless and slotless)
Drive System	Direct drive, crystal lock control system
Speed	33 1/3 rpm, 45 rpm
Starting characteristics	comes to nominal speed within a third revolution (33 1/3 rpm)
Wow and flutter	±0.045% (DIN) 0.025% (WRMS)
S/N ratio	73 dB (DIN-B)
Initial drift	within 0.0003%
Load characteristics	at 150 g tracking force 0%
Speed deviation	within 0.003%
Tonearm	
Type	Statically balanced, universal pivot
Pivot to stylus length	216.5 mm (8 1/2")
Overall arm length	300 mm (11 7/8")
Overhang	16.5 mm (21/32")
Tracking error	+3°, -1°
Tracking-force adjustment range	0 - 3 g
Shell weight	10.5 g
Cartridge weight range	2.5 - 9.5 g 8 - 14.5 g (with extra weight)
General	
Power requirements	120 V ac, 60 Hz
Power consumption	8W
Dimensions	Approx. 445×150×375 mm (w/h/d) (17 1/2×5 7/8×14 3/4 inches)
Weight	Approx. 10.3 kg, net (22 lbs 12 oz) Approx. 12.1 kg, in shipping carton (26 lbs 11 oz)
Supplied accessories	45-rpm adaptor Extra weight Alignment protractor Screw driver Cartridge mounting screws (3 pairs) Shell

Design and specifications subject to change without notice.

TROUBLE CHECKS

The following chart will help correct most problems which may occur with the unit. If the problem persists after you have made these checks, consult your Sony Service Station or Sony dealer.

Impaired tone quality

- Turntable not level
- Unit incorrectly placed on or near a speaker
- Dusty stylus
- Worn stylus or defective record (The stylus life is approx. 400 hours of playing time.)
- Incorrect cartridge installation
- Improper tonearm balance
- Improper tracking force
- Improper setting of the Anti-skating Compensator
- Improper turntable speed

No audio from one channel

- Loose attachment of the shell to the tonearm
- Loose connection of phono cord
- Low volume level setting for one channel of the amplifier
- Incorrect connection of the shell lead wires

Groove skipping, Tonearm tends to skate out, Tonearm does not advance (record repeats)

- Turntable not level
- Defective record
- External vibrations
- Improper tracking force
- Improper setting of the Anti-skating Compensator

Steady low-pitched sound (hum)

- Loose ground wire connection to the amplifier
- Loose connection between the shell and the tonearm
- Incorrect connection of the shell lead wires
- Transit screws not removed

Loud rumble or low-frequency "howl" which occurs when playing a record at high sound levels (acoustic feedback*)

- Put the turntable on a sturdy surface.
- Put the turntable as far away from the speakers as possible.
- If the above does not rectify the problem, try commercially available acoustic insulators designed to be put between the feet and shelf.

* Acoustic feedback: The vibration of speakers is transmitted through the air or via solid objects (shelves, cabinets, floor, etc.) to the turntable, picked up by the cartridge stylus, amplified, and again reproduced through the speakers.