

METROLOGIC INSTRUMENTS, INC.

MS7320 InVista® Series
Installation and User's Guide

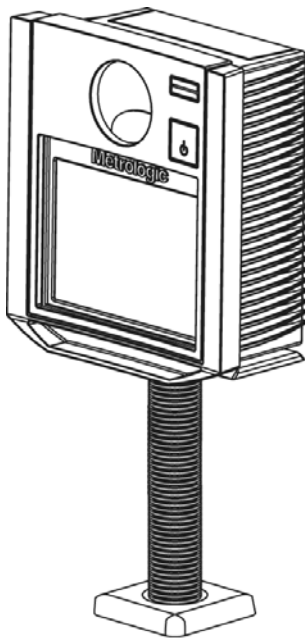

Copyright

© 2008 by Metrologic Instruments, Inc. All rights reserved. No part of this work may be reproduced, transmitted, or stored in any form or by any means without prior written consent, except by reviewer, who may quote brief passages in a review, or provided for in the Copyright Act of 1976.

Trademarks

Metrologic is a registered trademark of Metrologic Instruments, Inc. Products identified in this document are hereby acknowledged as trademarks, registered or otherwise, of Metrologic Instruments, Inc. or their respective companies.

TABLE OF CONTENTS

Introduction.....	1
Scanner and Accessories.....	2
Installation	
For OCIA Interface.....	4
For Keyboard Wedge Interface.....	5
For Stand-Alone Keyboard Interface	6
For USB Interface	7
For RS232 or Light Pen Interfaces	8
For IBM 46xx Interface	10
Of a Secondary Scanner.....	11
Scanner Parts.....	14
Maintenance.....	14
Cable Cover Installation and Removal	15
Face Plate Removal	15
Scanner Labels	16
Indicators	
Audible.....	17
Visual.....	18
Failure Mode.....	19
Power Save Modes and the Multi-Function Button.....	20
Scan Volume	22
Depth of Field by Minimum Bar Code Element Width.....	23
Flex Stand Installation	25
EAS Deactivation Antenna	28
Troubleshooting Guide	29
Design Specifications	34
RS232 Demonstration Program.....	36
Applications and Protocols	37
Configuration Modes	38
Upgrading the Firmware	39

TABLE OF CONTENTS

Default Settings	40
Scanner and Cable Terminations	
Scanner Pinout Connections	46
Cable Connector Configurations (Host End).....	48
Limited Warranty	50
Regulatory Compliance	
Safety	51
EMC.....	52
Patents	55
Index.....	56
Contact Information And Office Locations	58

INTRODUCTION

The MS7320 InVista® offers an outstanding combination of features, versatility, performance, and durability. This fixed mount laser bar code scanner provides ease of use and high throughput speeds by featuring a large, dynamic, and aggressive scan volume. Firmware updates are easily loaded into Flash memory.

The MS7320 is equipped with a multitude of standard features including:

- Automatic Scanning Operation
- EAS Deactivation Antenna
- A Configurable Depth of Field
- Supports Multiple Interfaces Including USB and Keyboard Wedge
- Custom Edit the Bar Code Data
- OPOS and JPOS System Compatible
- RS232 Auxiliary Port for Adding Peripherals
- PowerLink, User Replaceable Cables
- Field Replaceable Outer Window
- Sunrise 2005 Compliant

SCANNER	INTERFACE
MS7320-13	RS232, IBM 46xx, OCIA, Aux
MS7320-37	RS232, Light Pen, Keyboard Wedge, Stand-Alone Keyboard, USB, Aux

SCANNER AND ACCESSORIES

BASIC KIT	
Part #	Description
MS7320 InVista	Series Scanner
00-02407 MetroSelect	® Configuration Guide
00-02896	MS7320 InVista Series Installation and User's Guide
52-52511	24" EAS Cable

Guides also available for download at www.metrologic.com.

OPTIONAL ACCESSORIES	
Part #	Description
59-59xxx*	Straight PowerLink Cable with built in power jack. 2.1 m (7') cord with short strain relief
<i>xxx* specifies connection to the host. Contact a customer service representative for additional information.</i>	
59-59002	Keyboard Wedge PowerLink Cable with Adapter Cable
MVC**	<u>M</u> etrologic <u>V</u> oltage <u>C</u> onverter Cable, ±12VDC to +5.2VDC
<i>** Contact a Metrologic Customer Service representative for additional information on Metrologic's MVC cable series and the host connections available.</i>	
59-59020	Stand Alone Keyboard Wedge PowerLink Cable
59-59165	USB PowerLink Cable (Type A)
54-54667	RS232 AUX PowerLink Cable

SCANNER AND ACCESSORIES

OPTIONAL ACCESSORIES	
Part #	Description
AC to DC Power Transformer - Regulated 5.2V@ 1A output	
46-46759	120V United States
46-46616	220V – 240V Continental European
46-46615	220V – 240V United Kingdom
46-46984	220V – 240V China
46-46985	220V – 240V Australia
46-00174	3" Flex Stand
46-00157	6" Flex Stand
46-00175	12" Flex Stand

REPLACEMENT PARTS	
Part #	Description
46-46925	Standard Red Window Face Plate
46-46852	Pedestal Base <i>For use with 46-00174, 46-00175, and 46-00157 flex stands.</i>

Other items may be ordered for the specific protocol being used. To order additional items, contact the dealer, distributor or call Metrologic's Customer Service Department at 1-800-ID-METRO or 1-800-436-3876.

INSTALLATION FOR OCIA INTERFACE

1. Turn off the host system.
2. Connect the MVC cable to the 10-pin OCIA interface jack. It is the 2nd **round** opening from the left side of the MS7320 (see figure 1).
3. Connect the other end of the MVC cable to the host.



Before continuing verify that the MVC cable is connected to the appropriate interface jack on the scanner. An incorrect cable connection can cause communication problems or potential damage to the scanner.



Plugging the scanner into the serial port of the PC does not guarantee that scanned information will appear at the PC. A software driver and correct configuration settings are also required for proper communication.

4. Turn on the host system.
5. Scan the *Load OCIA Defaults* bar code to configure the MS7320 for OCIA communication.
6. Snap on the cable cover.

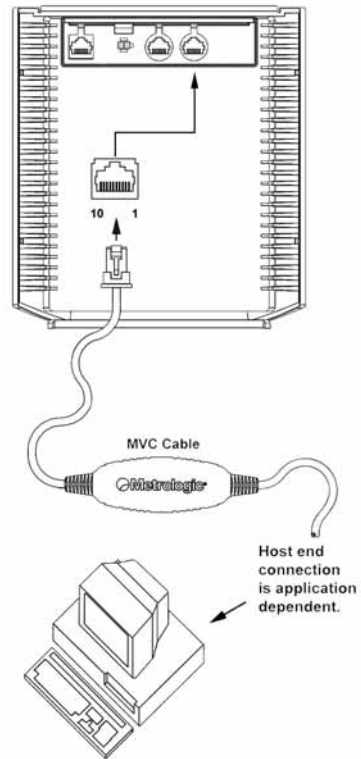
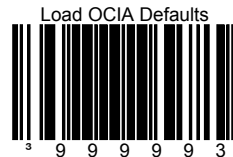

Figure 1: OCIA, Interface



For additional communication options for OCIA interfaces refer to the *MetroSelect Configuration Guide* (MLPN 00-02407).



See SELV Power Source caution statement located on page 16 of this manual.

INSTALLATION FOR KEYBOARD WEDGE INTERFACE

1. Turn off the host system.
2. Disconnect the keyboard from the host.
3. Connect the PowerLink cable to the 10-pin KBW interface jack. It is the 2nd **round** opening from the left side of the MS7320 (see figure 2).
4. Connect the “Y” end of the PowerLink cable to the keyboard and the keyboard port on the host. If necessary use the male/female adapter cable supplied with the scanner for proper connections.



Before continuing verify that the PowerLink cable is connected to the appropriate interface jack on the scanner. An incorrect cable connection can cause communication problems or potential damage to the scanner.

5. Connect the external power supply to the power jack on the PowerLink cable.
6. Check the AC input requirements of the power supply to make sure the voltage matches the AC outlet.
7. Connect AC power to the transformer. The outlet should be near the equipment and easily accessible.
8. Scan the *Load Keyboard Wedge Defaults* bar code to configure the MS7320 for Keyboard Wedge communication.
9. Turn on the host system.
10. Snap on the cable cover.

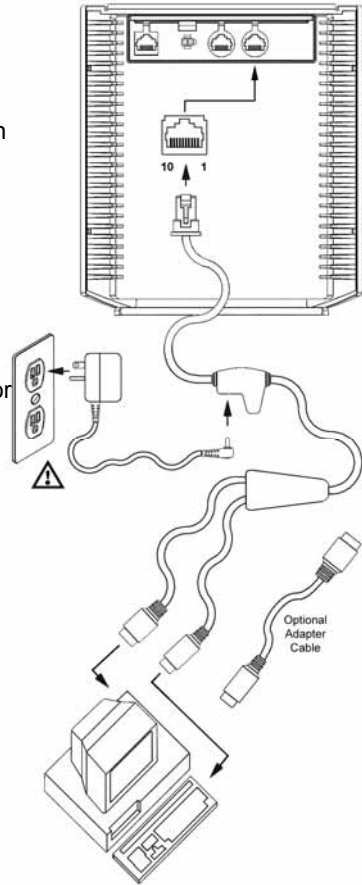
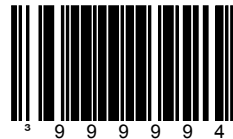

Figure 2: Keyboard Wedge Interfaces

Load Keyboard
Wedge Defaults



See SELV Power Source caution statement located on page 16 of this manual.

INSTALLATION FOR STAND-ALONE KEYBOARD INTERFACE

1. Turn off the host system.
2. Disconnect the keyboard from the host.
3. Connect the PowerLink cable to the 10-pin Stand-Alone Keyboard interface jack. It is the 2nd **round** opening from the left side of the MS7320 (see figure 3).
4. Connect the other end of the PowerLink cable to the keyboard port on the host.



Before continuing verify that the PowerLink cable is connected to the appropriate interface jack on the scanner. An incorrect cable connection can cause communication problems or potential damage to the scanner.

5. Connect the external power supply to the power jack on the PowerLink cable.
6. Check the AC input requirements of the power supply to make sure the voltage matches the AC outlet.
7. Connect AC power to the transformer. The outlet should be near the equipment and easily accessible.
8. Scan the two bar codes in numbered sequence in order to configure the MS7320 for Stand-Alone Keyboard communication.

Note:

When scanning the bar codes, cover the code not being scanned to ensure the codes are read in the proper sequence.

9. Turn on the host system.
10. Snap on the cable cover.

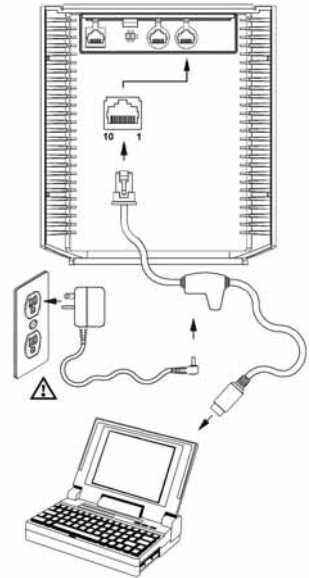
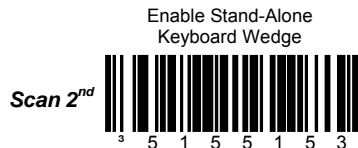
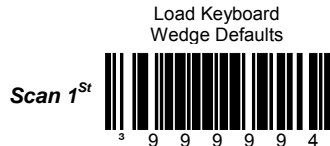

Figure 3: Stand-Alone Keyboard Interface



See SELV Power Source caution statement located on page 16 of this manual.

INSTALLATION FOR USB INTERFACE

1. Turn off the host system.
2. Determine if your application requires **USB Keyboard** communication protocols or **USB Point-of-Sale** communication protocols.
3. If you require **USB Keyboard** communication protocols, **skip** to step 4.

If you require **USB Point-of-Sale** communication protocols set the dip switches shown in *figure 4a* to positions 1 and 2.

4. Connect the PowerLink cable to the 10-pin USB interface jack. It is the 2nd **round** opening from the left side of the MS7320 (see *figure 4b*).
5. Connect the other end of the USB cable to the host.



Before continuing verify that the USB cable is connected to the appropriate interface jack on the scanner. An incorrect cable connection can cause communication problems or potential damage to the scanner.



Plugging the scanner into the USB port of the PC does not guarantee that scanned information will appear at the PC. A software driver and correct configuration setting are also required for proper communication.

6. Scan the *Enable USB Defaults* bar code to configure the MS7320 for USB communication.
7. Turn on the host system.
8. Snap on the cable cover.

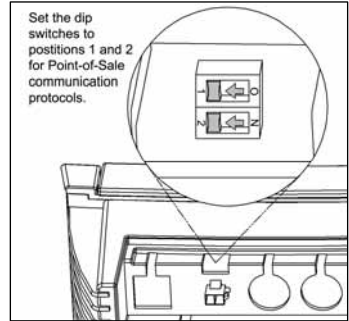

Figure 4a: POS Dip Switch

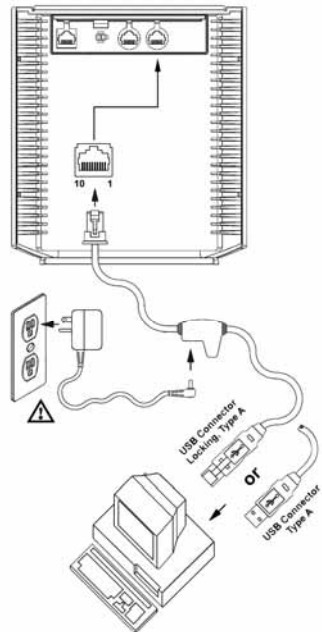

Figure 4b: USB, Interface



See SELV Power Source caution statement located on page 16 of this manual.

INSTALLATION FOR RS232 OR LIGHT PEN INTERFACES

1. Turn off the host system.
2. Connect the PowerLink cable to the 10-pin RS232/Light Pen interface jack. It is the 1st **round** opening from the left side of the MS7320 (see figure 5).
3. Connect the other end of the PowerLink cable to the host.



Before continuing verify that the PowerLink cable is connected to the appropriate interface jack on the scanner. An incorrect cable connection can cause communication problems or potential damage to the scanner.

4. Connect the external power supply to the power jack on the PowerLink Cable.
5. Check the AC input requirements of the power supply to make sure the voltage matches the AC outlet.
6. Connect AC power to the transformer. The outlet should be near the equipment and easily accessible.
7. Scan the appropriate bar codes on page 9 to configure the MS7320 for RS232 or Light Pen communication.
8. Turn on the host system.
9. Snap on the cable cover.

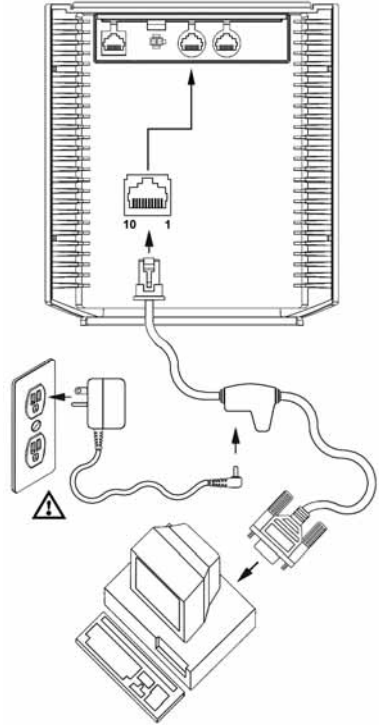

Figure 5: RS232 or Light Pen Interface



See SELV Power Source caution statement located on page 16 of this manual.

INSTALLATION FOR RS232 OR LIGHT PEN INTERFACES

Codes needed for Step 7 on page 8.

For RS232 Communication:



For Light Pen Communication:



INSTALLATION FOR IBM 46XX INTERFACE

1. Turn off the host system.
2. Connect the MVC cable to the 10-pin IBM 46xx interface jack. It is the 1st **round** opening from the left side of the MS7320 (see figure 6).
3. Connect the other end of the MVC cable to the host.



Before continuing verify that the MVC cable is connected to the proper communication jack on the scanner. Incorrect cable connection can cause communication problems or potential damage to the scanner.



Plugging the scanner into the serial port of the PC does not guarantee that scanned information will appear at the PC. A software driver and correct configuration setting are also required for proper communication to occur.

4. Turn on the host system.
5. Scan the *Load 46xx IBM Defaults* bar code to configure the MS7320 for RS232/IBM communication.
6. Snap on the cable cover

For additional communication options for IBM interfaces refer to the MetroSelect Configuration Guide (MLPN 00-02407).

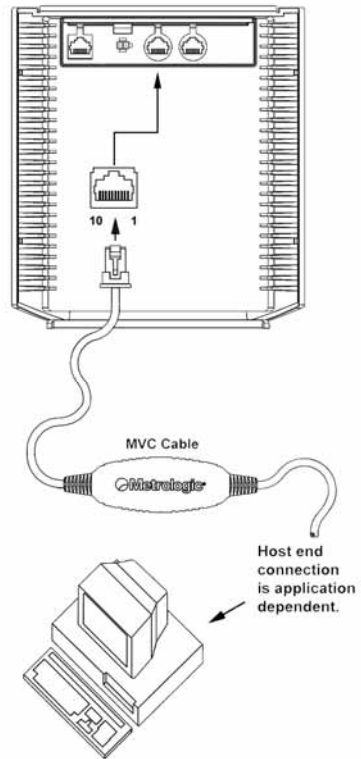

Figure 6: IBM 46xx Interface



See SELV Power Source caution statement located on page 16 of this manual.

INSTALLATION OF A SECONDARY SCANNER

1. Turn off the host system.
2. Connect the round end of the *PowerLink RS232 AUX* cable [MLPN 54-54667] to the RS232 jack of the auxiliary scanner (see figure 7).
3. Connect the other end of the *PowerLink RS232 AUX* cable into the 1st jack from the left side of the MS7320. The Aux jack has a **square** opening.

The following Metrologic scanners can be used in the "Aux" input of the MS7320: the MS9520, MS9540, MS6220, MS7120, MS6520, MS6720, MS7220 or another MS7320.



Important: The MS7320 aux port requires the signals: transmit, receive, RTS & CTS from the auxiliary scanner.

4. Connect the MS7320/Host PowerLink* cable to the appropriate interface jack on the back of the MS7320.
 5. Connect the other end of the MS7320/Host PowerLink cable to the Host.
 6. Connect the external power supplies for the auxiliary scanner and the MS7320 to the power jacks on the two PowerLink cables.
-  Before continuing verify that the PowerLink cables are connected to the appropriate interface jacks on the scanner. An incorrect cable connection can cause communication problems or potential damage to the scanner.
7. Check the AC input requirements of both power supplies to make sure the voltage matches the AC outlets.
 8. Snap on the cable cover.
 9. Connect AC power to the transformers. The outlets should be near the equipment and easily accessible.
 10. Configure the MS7320 for the appropriate interface configuration settings.*

Continued on page 12.

*The MS7320/host cable connection is interface dependent. Refer to the installation steps provided for the type of interface (*RS232, IBM 46xx, etc.*) required for your application.



See SELV Power Source caution statement located on page 16 of this manual.

INSTALLATION OF A SECONDARY SCANNER

11. Scan the following bar code to configure the auxiliary port on the MS7320 to accept a Metrologic scanner as the secondary scanner.



The following bar codes **do not apply** when using an MS6720 as a secondary scanner. Contact a Metrologic representative for additional information on the MS6720. If the secondary scanner is not a Metrologic scanner refer to Section O of the MetroSelect Configuration Guide.

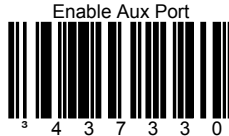

The auxiliary input port's data format must match the main output format of the secondary scanner.

12. Scan the following bar codes, in order, to configure the secondary scanner to match the auxiliary port's data format.

1st

Enable AUX Output



2nd

Secondary Scanner Data Format



3rd

Enable Comm Timeouts



4th (Optional)

Turn OFF Secondary Scanner's Beeper



13. Turn on the host system.

INSTALLATION OF A SECONDARY SCANNER

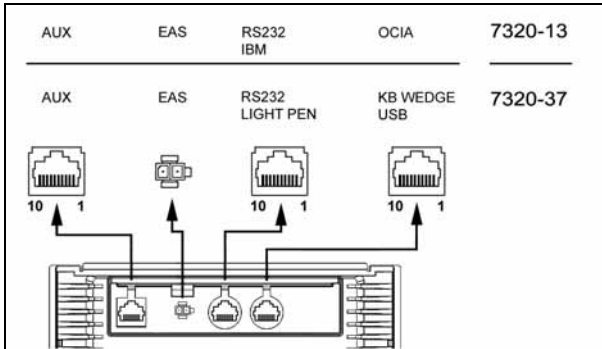
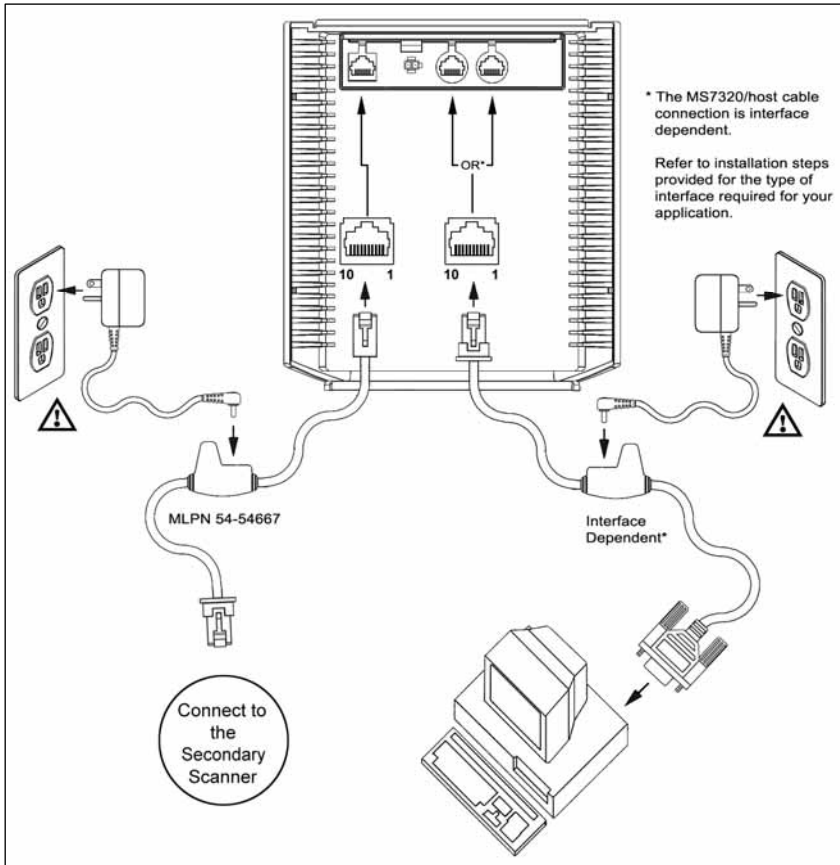

Figure 7: Connector Orientation (Top)
Auxiliary Scanner Setup (Bottom)



SCANNER PARTS

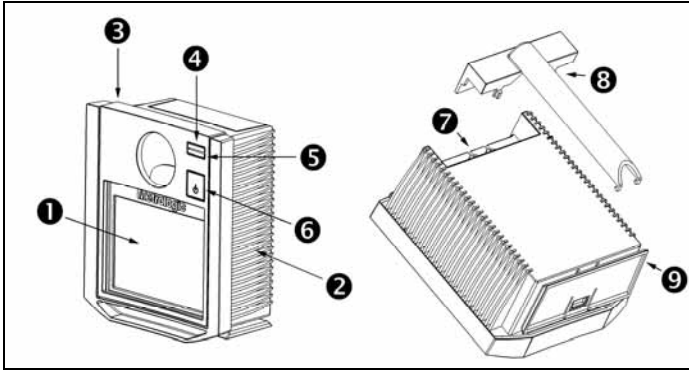

Figure 8: Scanner Parts

- 1** Output Window (Laser Aperture)
- 2** Speaker
- 3** Replaceable Window Face Plate
- 4** Red LED (*Top LED*)
- 5** Green LED (*Bottom LED*)
- 6** Multi-Function Button (*see page 21*)
- 7** Cable Connection and Dip Switch Area
- 8** Cable Cover
- 9** Pedestal Base/Stand Foot

MAINTENANCE

Smudges and dirt on the unit's window can interfere with the unit's performance. If the glass window requires cleaning, use only a mild glass cleaner containing no ammonia. When cleaning the window, spray the cleaner onto a lint free, non-abrasive cleaning cloth then gently wipe the window clean. If the red window requires cleaning use mild soap and water with a lint free, non-abrasive cleaning cloth then gently wipe the window clean.

If the unit's case requires cleaning, use a mild cleaning agent that does not contain strong oxidizing chemicals. Strong cleaning agents may discolor or damage the unit's exterior.

CABLE COVER INSTALLATION AND REMOVAL

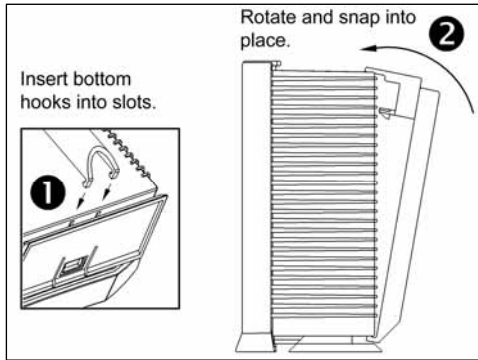
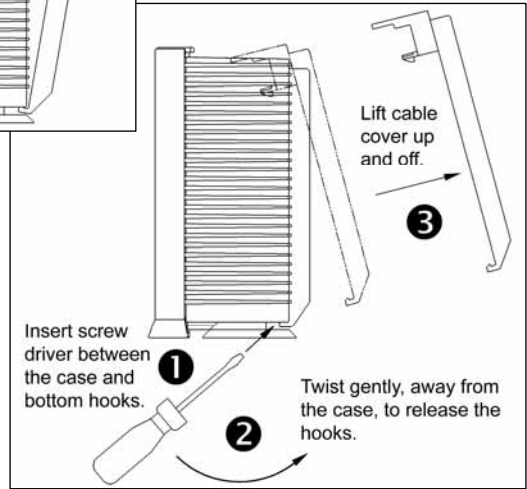

Figure 9:
Installing the Cable Cover (left).
Removing the Cable Cover (bottom right).



FACE PLATE REMOVAL

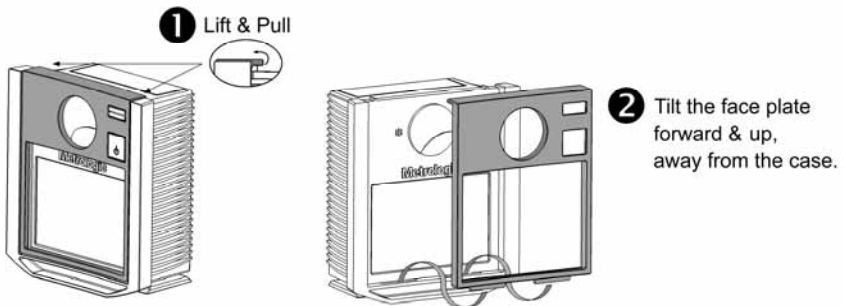
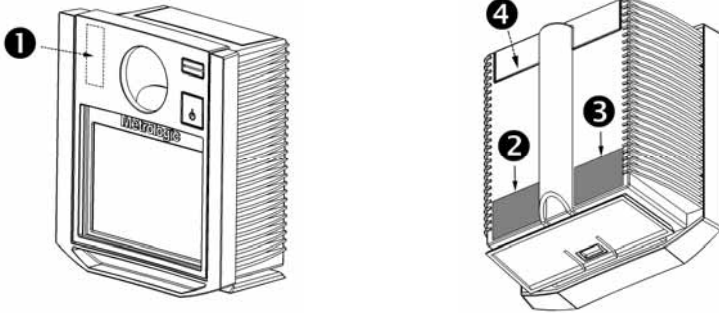

Figure 10: Face Plate Removal

SCANNER LABELS

The MS7320 has 2 labels on the back of the unit. These labels contain the model number, date of manufacture, serial number, and caution information. An additional caution label is located under the *window faceplate* and a label noting the jack interfaces is located under the connector cover. The following are examples of these labels.

Figure 11: Scanner Labels



1

CAUTION - CLASS 2 LASER LIGHT WHEN OPEN.
DO NOT STARE INTO BEAM. ATTENTION - CLASSE 2
RAYONNEMENT LASER EN CAS D'OUVERTURE. NE PAS
REGARDER DANS LE FAISCEAU.

2

Metrologic Instruments, Inc.
Blackwood, New Jersey, U.S.A. (C) 13
Manufactured: October 2006
Blackwood, N.J., U.S.A.
InVista® Barcode Scanner 5V ---
Model: MS7320 IBM/OCIA/RS232
43 06 43 0001
Complies with 21 CFR 1040.10
and 1040.11 except deviations
pursuant to Laser Notice No.
50 dated July 26, 2001.
Please See Manual.
Contains no user serviceable components.

CE c UL US LISTED 94J8 I.T.E.

3

CAUTION - CLASS 2 LASER LIGHT WHEN OPEN.
DO NOT STARE INTO BEAM. ATTENTION - CLASSE 2
RAYONNEMENT LASER EN CAS D'OUVERTURE. NE PAS
REGARDER DANS LE FAISCEAU.
IEC 60825-1:1993+A2:2001

**CLASS 1 LASER PRODUCT
APPAREIL A LASER DE
CLASSE 1**

**LASER KLASSE 1
PRODUKT**

4

AUX	EAS	RS232 IBM	OCIA	7320-13
AUX	EAS	RS232 LIGHT PEN	KB WEDGE USB	7320-37

See serial number label for applicable interfaces.

 To maintain compliance with applicable standards, all circuits connected to the scanner must meet the requirements for SELV (Safety Extra Low Voltage) according to EN/IEC 60950-1.

To maintain compliance with standard CSA C22.2 No. 60950-1/UL 60950-1 and norm EN/IEC 60950-1, the power source should meet applicable performance requirements for a limited power source.

AUDIBLE INDICATORS

When the MS7320 scanner is in operation, it provides audible feedback. These sounds indicate the status of the scanner. Eight settings are available for the tone of the beep (normal, 6 alternate tones and no tone). To change the tone, use the *Multi-Function Button* or refer to the MetroSelect Configuration Guide.



One Beep

When the scanner *first* receives power, the green LED will turn on, the red LED will flash and the scanner will beep once. The red LED will remain on for the duration of the beep. The scanner is now ready to scan.

When the scanner *successfully* reads a bar code, the red LED will flash and the scanner will beep once (if configured to do so). If the scanner does not beep once and the red light does not flash, then the bar code has *not* been successfully read.



Razzberry Tone

This is a failure indicator. Refer to failure modes on page 19.

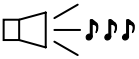

Three Beeps - during operation

When placing the scanner in program mode, the red LED will flash while the scanner simultaneously beeps three times. The red and green LEDs will continue to flash until the unit exits program mode. Upon exiting program mode, the scanner will beep three times and the red LED will stop flashing.

When configured, three beeps can also indicate a communications timeout during normal scanning mode.

When using one-code-configuring, the scanner will beep three times (the current selected tone), followed by a short pause, a high tone and a low tone. This tells the user that the single configuration bar code has *successfully* configured the scanner.

Three beeps will also occur during a manual adjustment of the beeper tone. With each short depression of the *Multi-Function Button*, the new tone will be heard, followed by a short pause then two more of the new current tones.

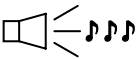

Three Beeps - on power up

This is a failure indicator. Refer to failure modes on page 19.

VISUAL INDICATORS

There is a red LED and green LED on the front of the MS7320. When the scanner is on, the flashing or constant illumination of the LEDs indicates the status of the current scan and the scanner.

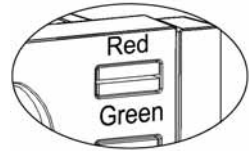

Figure 12: LEDs



No Red or Green LED

The LEDs will not be illuminated if the scanner is not receiving power from the host or transformer.



Steady Green

When the laser is active, the green LED is illuminated. The green LED will remain illuminated until the laser is deactivated.

During the power save mode, the laser will turn on and off. During this period, the green LED remains illuminated.



Steady Green and Single Red Flash

When the scanner successfully reads a bar code, the red LED will flash and the scanner will beep once. If the red LED does not flash or the scanner does not beep once, then the bar code has not been successfully read.



Steady Green and Steady Red

After a successful scan, the scanner transmits the data to the host device. Some communication modes require that the host inform the scanner when data is ready to be received. If the host is not ready to accept the information, the scanner's red LED will remain on until the data can be transmitted.

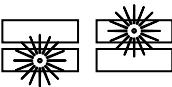

Flashing Green then Flashing Red

This indicates the scanner is in program mode. A razzberry tone indicates that an invalid bar code has been scanned in this mode.

or

If the unit is in sleep mode, each LED will flash once every 15 seconds.



Steady Red, Green off

This indicates the scanner may be waiting for communication from the host.

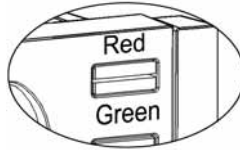
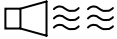

Figure 13: LEDs



Flashing Green and One Razzberry Tone

This indicates the scanner has experienced a laser subsystem failure. Return the unit for repair at an authorized service center.



Flashing Red and Green and Two Razzberry Tones

This indicates the scanner has experienced a motor failure. Return the unit for repair at an authorized service center.

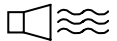

Continuous Razzberry Tone with both LEDs off

If, upon power up, the scanner emits a continuous razzberry tone, then the scanner has an electronic failure. Return the unit for repair at an authorized service center.

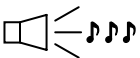

Three Beeps - on power up

If the scanner beeps 3 times on power up then, the nonvolatile memory that holds the scanner configuration has failed. Return the unit for repair at an authorized service center.

POWER SAVE MODES AND THE MULTI-FUNCTION BUTTON

The MS7320 has five configurable power save modes. Refer to the *MetroSelect Configuration Guide* for additional information on Power Save Modes.

1. **Blink Power Save Mode (Default):**

“Blinks” the laser OFF & ON after a configured period of non-use.
When the scanner recognizes a bar code it will exit the Blink mode.

2. **Laser Off Power Save Mode:**

Turns the laser OFF after a configured period of non-use.
The motor continues to spin allowing for a faster “wake” up time. Pressing the Multi-Function button will “wake” the scanner from the *Laser Off* power save mode (see figure 17).

3. **Laser & Motor Off Power Save Mode:**

Turns the laser and motor OFF after a configured period of non-use.
Pressing the Multi-Function button will “wake” the scanner from the power save mode (see figure 17). This mode is the only power save mode that can be activated by the Multi-Function Button (see figure 16). This mode’s “wake up” time is slightly longer due to the motor’s need to restart.

4. **Dual Action Power Save Mode #1:**

“Blinks” the laser OFF & ON after a configured period of non-use turns the laser and motor OFF at thirty-minute intervals.

Example:

If the power save timeout is set to 15 minutes.

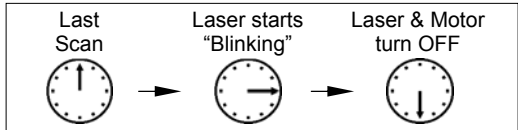

Pressing the Multi-Function button will “wake” the scanner from the power save mode (see figure 17).

5. **Dual Action Power Save Mode #2:**

Turns the laser OFF after a configured period of non-use then turns the motor OFF after thirty-minute intervals.

Example:

If the power save timeout is set to 15 minutes.

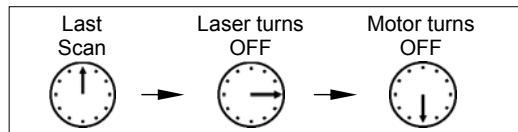

Pressing the Multi-Function button will “wake” the scanner from the power save mode (see figure 17).

POWER SAVE MODES AND THE MULTI-FUNCTION BUTTON

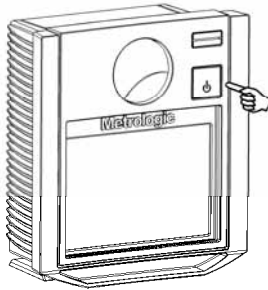

Figure 14: The Multi-Function Button



Figure 15: Changing the Beeper Tone

CHANGING THE BEEPER TONE

A short (<3 second) depression and the beeper tone will change. The new tone will be heard, followed by a short pause. Then two more of the new tones will be heard signifying the new setting has been stored in memory. The silent (no beep) tone is also selectable.



Figure 16: Laser & Motor Off Power Save Mode

PLACING THE UNIT IN LASER & MOTOR OFF POWER SAVE MODE

Long (>3 seconds) depression
The *Laser & Motor Off Power Save Mode* is the only power save mode that can be activated with the multi-function button.



Figure 17: Normal Operation

WAKING THE UNIT FROM ALL POWER SAVE MODES

The next button depression will awaken the scanner for normal operation.

SCAN VOLUME

(BASED ON 100% UPC BAR CODES)

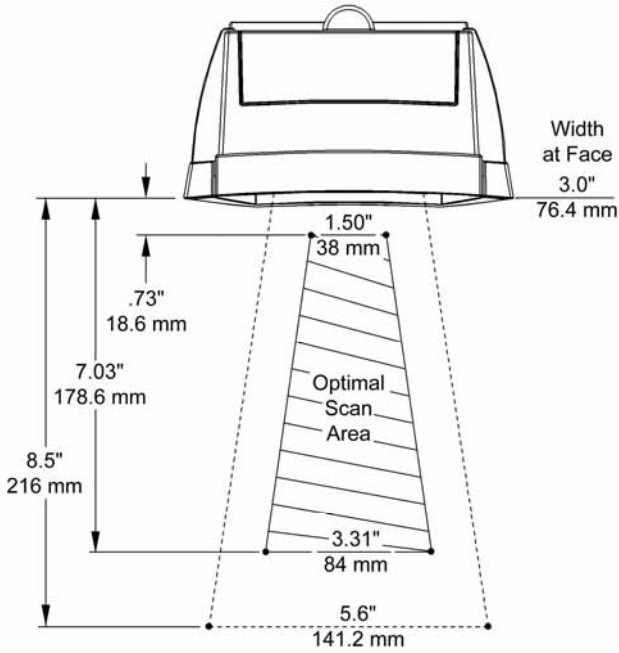
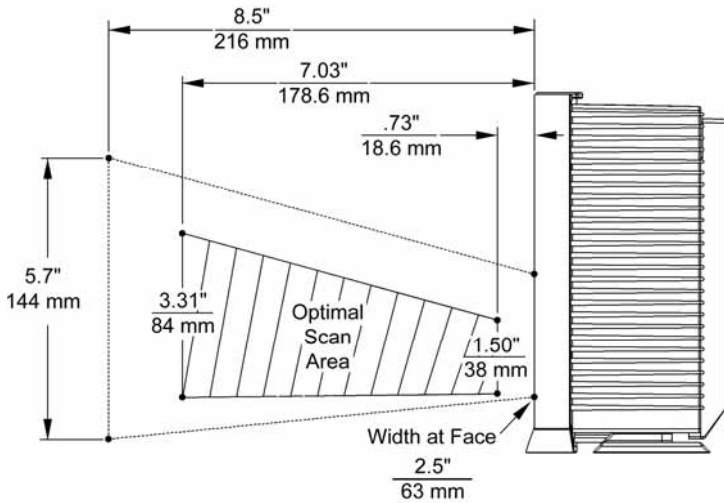

Figure 18: Scan Area Top View (top) Side View (Bottom)



Specifications are subject to change without notice.

DEPTH OF FIELD BY MINIMUM BAR CODE ELEMENT WIDTH

(BASED ON 100% UPC BAR CODES)

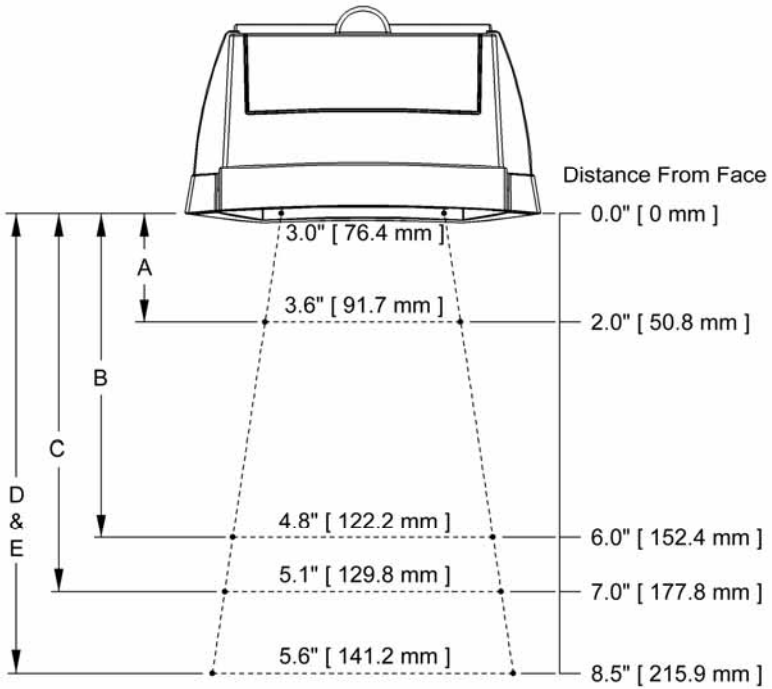

Figure 19: Depth of Field Top View

Minimum Bar Code Element Width					
	A	B	C	D	E
mm	.13 .19	.26 .33 .48			
mils	5.2 7.5		10.4	13	19

Specifications are subject to change without notice.

DEPTH OF FIELD BY MINIMUM BAR CODE ELEMENT WIDTH

(BASED ON 100% UPC BAR CODES)

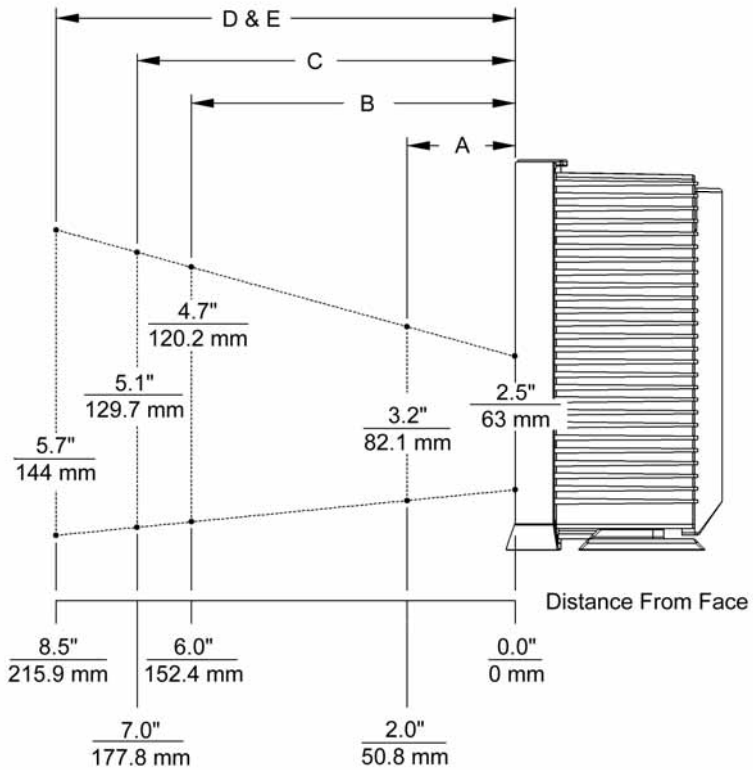

Figure 20: Depth of Field Side View

Minimum Bar Code Element Width					
	A	B	C	D	E
mm	.13 .19 .26 .33 .48				
mils	5.2 7.5		10.4	13	19

Specifications are subject to change without notice.

FLEX STAND INSTALLATION

Flex Stand (Optional), Kit Components

- a. Stand Base Cover Qty. 1
- b. Stand Base Qty. 1
- c. Small Flex Cover* Qty. 1
- d. Flex Pole* Qty. 1
- e. Large Flex Cover* Qty. 1
- f. #8 x 1.00" Wood Screw Qty. 4
- g. 1/4"-20 x 3/4" Flat Head Screw .. Qty. 1
- h. 1/4" External Lock Washer Qty. 2
- i. 1/4" Flat Washer Qty. 1

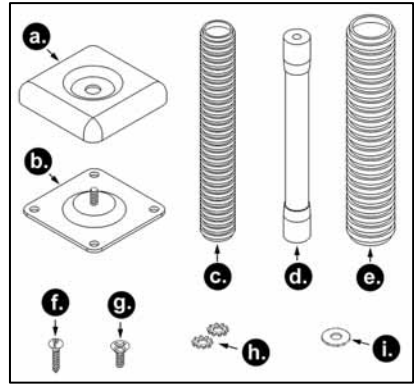

Figure 21: Flex Stand Parts

* Flex pole length and flex cover quantities are kit dependent.			
Kit Number	Flex Pole Length (d.)	Flex Cover Qty.	
		Small (c.)	Large (e.)
46-00174	3"	1	Not Applicable
46-00157	6"	1	1
46-00175	12"	2	1

Installation

1. Drill four #39 pilot holes in the counter top for the stand base.

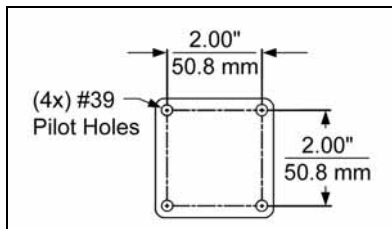

Figure 22: Hole Pattern

FLEX STAND INSTALLATION

2. Secure the base plate to the counter and attach the flex pole assembly. Slide the flex cover(s)* over the flex pole assembly.

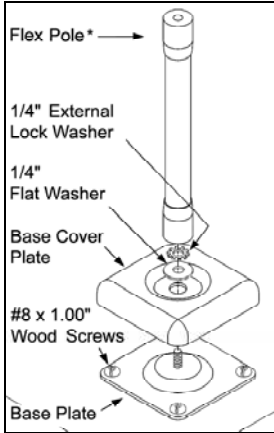

Figure 23: Pole Assembly

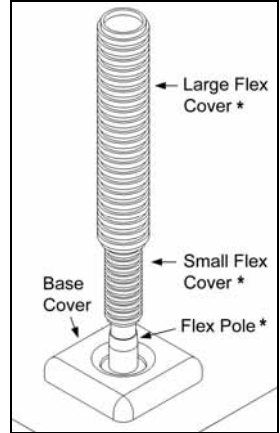

Figure 24: Cover Assembly

3. Remove the scanner's cable cover if it was previously installed.

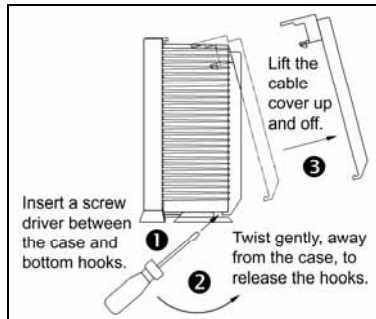

Figure 25: Cable Cover Removal

4. Pull the tab on the scanner's pedestal to release the lock. Slide the pedestal off the scanner.

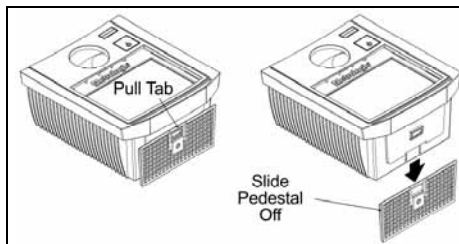

Figure 26: Pedestal Removal

FLEX STAND INSTALLATION

5. Attach the scanner pedestal to the flex pole.

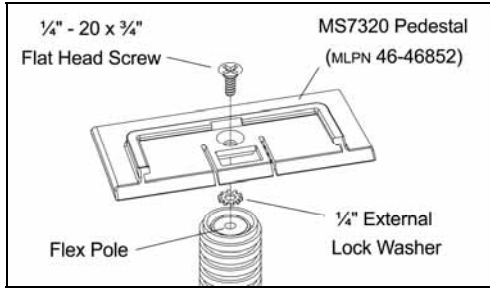

Figure 27: Attach Pedestal to Pole

6. Slide the scanner onto the pedestal until it clicks locking the scanner to the stand.

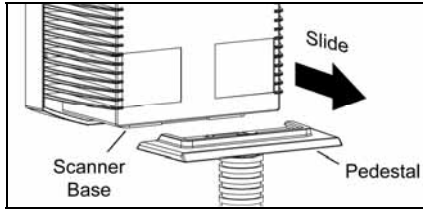

Figure 28: Install Pedestal to Scanner

7. **Before** installing the scanner's cable cover, refer to pages 4-13 for instructions on the proper cable connections.
8. Install the scanner's cable cover.

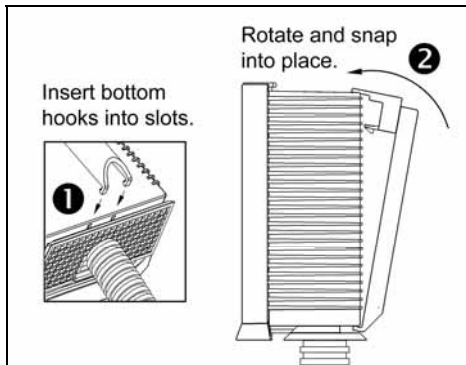



Figure 29: Install Cable Cover

EAS DEACTIVATION ANTENNA

SW1 and SW2 are the switch banks inside the Checkpoint Device that set the deactivation range. Metrologic recommends end users program the MS7320 to the *Fixed for Low Density Codes - Depth of Field**, so that the unit does not scan out beyond the deactivation range.

Unit #	Checkpoint Recommended Switch Bank Settings	MS7320 Depth of Field Recommended Settings
MS7320	SW1 - 2, 3, 4, 5, 6 set to ON & SW2 - 2, 3, 4, 5, 6 set to ON	Fixed for Low Density Codes Depth of Field Adjustments* 
* Note: Minimum element width changes to 6.8 mil when in this mode.		

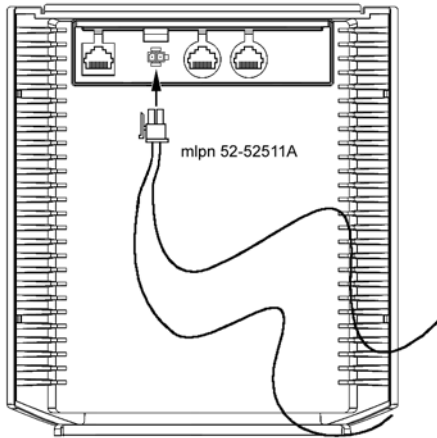

Figure 30: EAS Deactivation Antenna

Contact Checkpoint Systems directly for additional EAS support.

TROUBLESHOOTING GUIDE

The following guide is for reference purposes only. Contact a Metrologic representative at 1-800-ID-METRO or 1-800-436-3876 to preserve the limited warranty terms.

MS7320 SERIES TROUBLESHOOTING GUIDE		
SYMPTOMS	POSSIBLE CAUSE(S)	SOLUTION
<i>All Interfaces</i>		
No LEDs, beep or motor spin.	No power is being supplied to the scanner.	Check transformer, outlet and power strip. Make sure the cable is plugged into the scanner.
No LEDs, beep.	No power is being supplied to the scanner from host.	Some host systems cannot supply enough current to power MS7320 series scanner. Use the power supply included with the scanner.
3 beeps on power up.	Non-volatile RAM failure.	Contact a Metrologic Representative, if the unit will not hold the configuration.
Continuous razz tone on power up.	Diagnostic Failure.	Contact a Metrologic Representative, if the unit will not function.
Razz tone and green LED flash at power up.	VLD failure.	Contact a Metrologic Representative.
	Scanner motor failure.	Contact a Metrologic Representative.
Multiple scans upon presentation of code.	Same symbol timeout set too short.	Adjust same symbol timeout for a longer time.
The unit powers up but does not beep.	Beeper disabled No volume is selected No tone is selected.	Enable beeper Select volume (configurable) Select tone.

TROUBLESHOOTING GUIDE

SYMPTOMS	POSSIBLE CAUSE(S)	SOLUTION
<p>The unit powers up, but does not scan and/or beep.</p>	<p>Scanning a particular symbology that is not enabled.</p>	<p>UPC/EAN, Code 39, interleaved 2 of 5, Code 93, Code 128 and Codabar are enabled by default. Verify that the type of bar code being read has been selected.</p>
	<p>The scanner has been configured for a character length lock, or a minimum length and bar code being scanned does not satisfy the configured criteria.</p>	<p>Verify that the bar code that is being scanned falls into the criteria. (Typical of Non-UPC/EAN codes. <i>The scanner defaults to a minimum of 4 character bar code.</i>)</p>
<p>The unit scans a bar code, but locks up after the first scan (red LED stays on).</p>	<p>The scanner is configured to support some form of host handshaking but is not receiving the signal.</p>	<p>If the scanner is setup to support ACK/NAK, RTS/CTS, XON/XOFF or D/E, verify that the host cable and host are supporting the handshaking properly.</p>
<p>The unit scans, but the data transmitted to the host is incorrect.</p>	<p>The scanner's data format does not match the host system requirements.</p>	<p>Verify that the scanner's data format matches that required by the host. Make sure that the scanner is connected to the proper host port.</p>

TROUBLESHOOTING GUIDE

SYMPTOMS	POSSIBLE CAUSE(S)	SOLUTION
Scanner beeps at some bar codes and NOT for others of the same bar code symbology.	The bar code may have been printed incorrectly.	Check if it is a check digit/character/or border problem.
	The scanner is not configured correctly for this type of bar code.	Check if check digits are set properly.
	The minimum symbol length setting does not work with the bar code.	Check if the correct minimum symbol length is set.
Multi-Function Button is not working.	Dirt could be preventing the button from compressing fully.	Make sure the button area is clean and the button can move freely.
	A faulty push button switch.	Contact a Metrologic Customer Service Representative.
Keyboard Wedge Only		
The unit scans the bar code but there is no data.	Configuration is not correct.	Make sure the scanner is configured for the appropriate mode.
The unit scans but the data is not correct.	Configuration is not correct.	Make sure that the proper PC type AT, PS2 or XT is selected. Verify correct country code and data formatting are selected. Adjust the intercharacter delay SYMPTOM.
The unit is transmitting each character.	Configuration is not correct.	Increase the interscan code delay setting. Adjust whether the F0 break is transmitted. It may be necessary to try this in both settings.
Alpha characters show as lower case.	Computer is in Caps Lock mode.	Enable Caps Lock detect setting of the scanner to detect whether the PC is operating in Caps Lock.

TROUBLESHOOTING GUIDE

SYMPTOMS	POSSIBLE CAUSE(S)	SOLUTION
Everything works except for a couple of characters.	These characters may not be supported by that country's key look up table.	Try operating the scanner in Alt mode.
RS232 Only		
The unit is transmitting each character.	Configuration is not correct.	Increase the interscan code delay setting. Adjust whether the F0 break is transmitted. It may be necessary to try this in both settings.
Alpha characters show as lower case.	Computer is in Caps Lock mode.	Enable the caps lock detect setting of the scanner to detect if the PC is operating in Caps Lock.
Everything works except for a couple of characters.	These characters may not be supported by that country's key look up table.	Try operating the scanner in Alt mode.
Power-up OK and scans OK but does not communicate properly to the host.	Com port at the host is not working or configured properly.	Check to make sure that the baud rate and parity of the scanner and the communication port match and the program is looking for "RS232" data.
	Com port not operating properly.	
	Cable not connected to the proper com port.	

TROUBLESHOOTING GUIDE

SYMPTOMS	POSSIBLE CAUSE(S)	SOLUTION
The host is receiving data but the data does not look correct.	The scanner and host may not be configured for the same interface.	Check that the scanner and the host are configured for the same interface.
Characters are being dropped.	Intercharacter delay needs to be added to the transmitted output.	Add some intercharacter delay to the transmitted output by using the MetroSelect Configuration Guide (MLPN 00-02407).
Aux Port Operation with any Interface		
Trouble with the secondary scanner.		Refer to the user guide provided with the secondary scanner.
Secondary scanner powers up but data is not relayed to the host.	Cable [MLPN 54-54667] may not be connected to the proper port.	Ensure the secondary scanner is connected to the MS7320 com port marked "Aux" port.
	The "Aux" com port may not be operating properly.	* The MS7320 must be configured to enable the "Aux" port.
		The secondary scanner must be configured to send 'secondary' formatted data (reserve code 32).
* Use MetroSet®. For the Auxiliary interface, choose "HoloTrak Decode". All remaining parameters will be automatically chosen.		
USB Only		
The scanner Powers up ok, scans ok but does not communicate.	The USB Port is not operating correctly.	Check that the scanner is configured for USB operation. Check that the host's USB port is enabled.
The scanner emits a razz tone and the LEDS flash three times when configured for USB.	The USB port is not operating correctly.	Disconnect then reconnect the USB cable at the host end. Contact a Metrologic Representative if symptoms persist.

DESIGN SPECIFICATIONS

MS7320 SERIES DESIGN SPECIFICATIONS	
OPERATIONAL	
Light Source:	V isible L aser D iode (VLD) @ 650 nm
Laser Power:	0.678 mW (peak)
Depth of Field:	0 mm to 215 mm (0"- 8.5") for 0.33 mm (13 mil) bar code
Width of Scan Field:	38 mm (1.5") @ 15 mm (0.6"); 135 mm (5.3") @ 191 mm (7.5")
Scan Speed:	2000 scans/second
Scan Pattern:	5 fields of 4 parallel lines (omnidirectional)
Scan Lines:	20
Min Bar Width:	0.127 mm (5.0 mil)
Decode Capability:	Autodiscriminates all standard bar codes; for other symbologies call Metrologic
System Interfaces:	PC Keyboard Wedge, RS232, OCIA, Light Pen, Stand Alone PC Keyboard, USB, IBM 468x/469x
Print Contrast:	35% minimum reflectance difference
No. Characters Read:	up to 80 data characters (Maximum number will vary based on symbology and density)
Roll, Pitch, Yaw:	360°, 60°, 60°
Beeper Operation:	7 tones or no beep
Indicators (LED):	green = laser on, ready to scan red = good read, decoding
MECHANICAL	
Dimensions:	185 mm (7.3") H, 99 mm (3.9") D, 168 mm (6.6") W
Footprint of Stand	64 mm (2.5") x 64 mm (2.5")
Weight:	1.2 Kg (2.65 lbs)
Termination:	Three 10-pin modular RJ45 jacks
Cable:	Standard 2.1m (7') straight; for other cables call Metrologic

Specifications are subject to change without notice.

DESIGN SPECIFICATIONS

MS7320 SERIES DESIGN SPECIFICATIONS	
ELECTRICAL	
Input Voltage:	5.2VDC \pm 0.25V
Power:	1.9 W
Operating Current:	360 mA
DC Transformers:	Class II; 5.2 VDC @ 1A
<i>For Regulatory Compliance Information refer to pages 51 -54.</i>	
ENVIRONMENTAL	
Operating Temperature:	0°C to 40°C (32°F to 104°F)
Storage Temperature:	-40°C to 60°C (-40°F to 140°F)
Humidity:	5% to 95% relative humidity, non-condensing
Light Levels:	Up to 4842 LUX (450 foot candles)
Contaminants:	Sealed to resist airborne particulate contaminants
Ventilation:	None required

Specifications are subject to change without notice.

RS232 DEMONSTRATION PROGRAM

If an RS232 scanner is not communicating with your IBM compatible PC, key in the following BASIC program to test that the communication port and scanner are working. This program is for demonstration purposes only. It is only intended to prove that cabling is correct, the com port is working, and the scanner is working. If the bar code data displays on the screen while using this program, it only demonstrates that the hardware interface and scanner are working. At this point, investigate whether the application software and the scanner configuration match. If the application does not support RS232 scanners, a software wedge program that will take RS232 data and place it into a keyboard buffer may be needed. This program tells the PC to ignore RTS-CTS, Data Set Ready (DSR) and Data Carrier Detect (DCD) signals. If the demonstration program works and yours still does not, jumper RTS to CTS and Data Terminal Reading (DTR) to DCD and DSR on the back of your PC.

```
10 CLS
20 ON ERROR GOTO 100
30 OPEN "COM1:9600,S,7,1,CS0,DS0,CD0,LF" AS #1
35 PRINT "SCAN A FEW BAR CODES"
40 LINE INPUT #1, BARCODE$
50 PRINT BARCODE$
60 K$ = INKEY$: IF K$ = CHR$(27) THEN GOTO 32766
70 GOTO 40
100 PRINT "ERROR NO. "; ERR; " PRESS ANY KEY TO TERMINATE."
110 K$ = INKEY$: IF K$ = "" THEN GOTO 110
32766 CLOSE: SYSTEM
32767 END
```

APPLICATIONS AND PROTOCOLS

The model number on each scanner includes the scanner number and factory default communications protocol.

SCANNER	VERSION IDENTIFIER	COMMUNICATION PROTOCOL(S)
7320	13	RS232, IBM 46xx, OCIA, Aux
	37	RS232, Light Pen, Keyboard Wedge, Stand-Alone Keyboard, USB, Aux

The MS7320 with Built-in PC Keyboard Wedge Interface is designed to be used for keyboard emulation only. Many RS232 configurable functions available in other Metrologic scanners are also available as keyboard wedge functions.

The following are the most important selectable options specific to the keyboard wedge.

Keyboard Type

- ** AT (includes IBM® PS2 models 50, 55, 60, 80)
- XT
- IBM PS2 (includes models 30, 70, 8556)

Keyboard Country Type

- ** USA
- Belgian
- French
- German
- Hungarian
- Italian
- Japanese
- Russian Cyrillic
- Slovenian
- Spanish
- Swiss
- Swedish/Finnish
- Turkish
- United Kingdom

** Refer to pages 40-45 for complete information on the factory default settings. Refer to the MetroSelect Configuration Guide (MLPN 00-02407) or MetroSet 2's help files for information on how to change the default settings.

CONFIGURATION MODES

The MS7320 has three modes of configuration.

- **Bar Codes**

The MS7320 can be configured by scanning the bar codes included in the Metrologic Configuration Guide shipped with the area imager.

This manual can also be downloaded FREE from Metrologic's website (www.metrologic.com).

- **MetroSet2**

This user-friendly Windows-based configuration program allows you to simply 'point-and-click' at the desired scanner options. This program can be downloaded for FREE from Metrologic' website (www.metrologic.com) or set-up disks can be ordered by calling 1-800-ID-METRO.

- **Serial Programming**

This mode of configuration is ideal for OEM applications. This mode gives the end-user the ability to send a series of commands using the serial port of the host system. The commands are equivalent to the numerical values of the bar codes located in the MetroSelect Configuration Guide (MLPN 00-02407).

UPGRADING THE FIRMWARE

The MS7320 is part of Metrologic's line of scanners with flash upgradeable firmware. The upgrade process requires, a new firmware file supplied to the customer by a customer service representative♦ and Metrologic's MetroSet2 software♦♦. A personal computer running Windows 95 or greater with an available RS232 serial or USB port is required to complete the upgrade.



Do not use the standard cable supplied with Keyboard Wedge or RS485 MS7320 interface kits for firmware upgrades. If using USB or RS232 for the upgrade process, the standard USB or RS232 cable provided with the scanner can be used.

To upgrade the firmware in the MS7320:

1. Plug the scanner into a serial communication port on the host system.
 2. Start the MetroSet2 software.
 3. Click on the plus sign (+) next to *POS Scanners* to expand the supported scanner list.
 4. Choose the MS7320 InVista from the list.
 5. Click on the Configure InVista/7320 Scanner button.
 6. Choose *Flash Utility* from the options list located on the left side of the screen.
 7. Click on the *Open File* button in the Flash Utility window.
 8. Locate and open the flash upgrade file supplied by Metrologic.
 9. Select the COM port that the scanner is connected to on the host system.
 10. Verify the settings listed in the Flash Utility window.
 11. Click on the *Flash Scanner* button to begin the flash upgrade.
 12. A message will appear on the screen when the upgrade is complete.
-
- ♦ Metrologic's customer service department can be reached at 1-800-ID-METRO or 1-800-436-3876.
 - ♦♦ MetroSet2 is available for download, at no additional cost, from <http://www.metrologic.com/corporate/download>.

DEFAULT SETTINGS

Many functions of the scanner can be "configured" - that is, enabled or disabled. The scanner is shipped from the factory configured to a set of default conditions. The default parameter of the scanner has an asterisk (*) in the charts on the following pages. If an asterisk is not in the default column then the default setting is Off or Disabled. Every communication does not support every parameter. If the communication supports a parameter listed in the charts on the following pages, a check mark (✓) will appear.

PARAMETER	DEFAULT	OCIA	RS232	LIGHT PEN	IBM 46XX	KBW	USB
UPC/EAN	*	✓	✓	✓	✓	✓	✓
Code 128	*	✓	✓	✓	✓	✓	✓
Code 93	*	✓	✓	✓	✓	✓	✓
Codabar	*	✓	✓	✓	✓	✓	✓
Interleaved 2 of 5 (ITF)	*	✓	✓	✓	✓	✓	✓
MOD 10 Check on ITF		✓	✓	✓	✓	✓	✓
Code 11		✓	✓	✓	✓	✓	✓
Code 39	*	✓	✓	✓	✓	✓	✓
Full ASCII Code 39		✓	✓	✓	✓	✓	✓
MOD 43 Check on Code 39		✓	✓	✓	✓	✓	✓
MSI-Plessey		✓	✓	✓	✓	✓	✓
Airline (15 Digit) 2 of 5		✓	✓	✓	✓	✓	✓
Airline (13 Digit) 2 of 5		✓	✓	✓	✓	✓	✓
Matrix 2 of 5		✓	✓	✓	✓	✓	✓
Telepen		✓	✓	✓	✓	✓	✓
UK Plessey		✓	✓	✓	✓	✓	✓
STD 2 of 5		✓	✓	✓	✓	✓	✓
MSI-Plessey 10/10 Check Digit		✓	✓	✓	✓	✓	✓
MSI-Plessey MOD 10 Check Digit	*	✓	✓	✓	✓	✓	✓
Paraf Support		✓	✓	✓	✓	✓	✓
ITF Symbol Lengths	Variable	✓	✓	✓	✓	✓	✓
Minimum Symbol Length	4	✓	✓	✓	✓	✓	✓
Symbol Length Lock	None	✓	✓	✓	✓	✓	✓
Bars High as Code 39	*			✓			

DEFAULT SETTINGS

PARAMETER	DEFAULT	OCIA	RS232	LIGHT PEN	IBM 46XX	KBW	USB
Spaces High as Code 39				✓			
Bars High as Scanned				✓			
Spaces High as Scanned				✓			
DTS/SIEMENS		✓					
DTS/NIXDORF	*	✓					
NCR F		✓					
NCR S		✓					
Poll Light Pen Source				✓			
Beeper Tone	Normal	✓	✓	✓	✓	✓	✓
Beep/Transmit Sequence	Before Transmit	✓	✓	✓	✓	✓	✓
Beeper Volume	Loudest	✓	✓	✓	✓	✓	✓
CommunicationTimeout	None	✓	✓	✓	✓	✓	✓
Razzberry Tone on Timeout		✓	✓	✓	✓	✓	✓
Three Beeps on Timeout		✓	✓	✓	✓	✓	✓
No Beeps on Timeout	*	✓	✓	✓	✓	✓	✓
Enter Power Save Mode	10 mins.	✓	✓	✓	✓	✓	✓
Blink Power Save Mode	*	✓	✓	✓	✓	✓	✓
Laser OFF Power Save Mode		✓	✓	✓	✓	✓	✓
Laser & Motor OFF Power Save Mode		✓	✓	✓	✓	✓	✓
Dual Action Power Save Mode #1		✓	✓	✓	✓	✓	✓
Dual Action Power Save Mode #2		✓	✓	✓	✓	✓	✓
Same Symbol Rescan Timeout: 200 msec		✓	✓	✓	✓	✓	✓
Same Symbol Rescan Timeout: 500 msec Configurable in 50 msec steps (MAX 6.35 seconds)	*	✓	✓	✓	✓	✓	✓
Same Symbol Rescan Timeout: 1250 msec		✓	✓	✓	✓	✓	✓

DEFAULT SETTINGS

PARAMETER	DEFAULT	OCIA	RS232	LIGHT PEN	IBM 46XX	KBW	USB
Same Symbol Rescan Timeout: 2000 msec		✓	✓	✓	✓	✓	✓
Intercharacter Delay Configurable in 1 msec steps (MAX 255 msec)	1 msec 10 msec in KBW	✓	✓		✓	✓	
Number of Scan Buffers	1	✓	✓	✓	✓	✓	✓
Transmit EAN-8 Check Digit	*	✓	✓		✓	✓	✓
Transmit EAN-13 Check Digit	*	✓	✓		✓	✓	✓
Transmit UPC-A Check Digit	*	✓	✓		✓	✓	✓
Transmit UPC-E Check Digit			✓		✓	✓	✓
Expand UPC-E		✓	✓		✓	✓	✓
Convert UPC-A to EAN-13		✓	✓		✓	✓	✓
UPC GTIN-14 Format		✓	✓		✓	✓	✓
Transmit Lead Zero on UPC-E		✓	✓	✓	✓	✓	✓
Convert EAN-8 to EAN-13		✓	✓		✓	✓	✓
Transmit UPC-A Number System	*	✓	✓	✓	✓	✓	✓
Transmit UPC-A Manufacturer ID#	*	✓	✓	✓	✓	✓	✓
Transmit UPC-A Item ID#	*	✓	✓	✓	✓	✓	✓
Transmit Codabar Start/Stop Characters		✓	✓		✓	✓	✓
CLSI Editing (Enable)		✓	✓		✓	✓	✓
Transmit Mod 43 Check Digit on Code 39		✓	✓		✓	✓	✓
Transmit Code 39 Stop/Start Characters		✓	✓		✓	✓	✓
Transmit Mod 10/ITF		✓	✓		✓	✓	✓
Transmit MSI-Plessey Check Characters		✓	✓		✓	✓	✓
Parity	Space		✓				
Baud Rate	9600		✓				

DEFAULT SETTINGS

PARAMETER	DEFAULT	OCIA	RS232	LIGHT PEN	IBM 46XX	KBW	USB
8 Data Bits			✓				
7 Data Bits	*		✓			✓	✓
Transmit Sanyo ID Characters			✓			✓	✓
Nixdorf ID			✓			✓	✓
LRC Enabled			✓			✓	✓
UPC Prefix			✓			✓	✓
UPC Suffix			✓			✓	✓
Transmit AIM ID Characters			✓			✓	✓
STX Prefix			✓			✓	✓
ETX Suffix			✓			✓	✓
Carriage Return	*		✓			✓	✓
Line Feed - disabled by default in KBW	*		✓			✓	✓
Tab Prefix			✓			✓	✓
Tab Suffix			✓			✓	✓
"DE" Disable Command			✓				✓
"FL" Laser Enable Command			✓				✓
DTR Handshaking Support			✓				
RTS/CTS Handshaking			✓				
Character RTS/CTS	*		✓				
Message RTS/CTS			✓				
XON/XOFF Handshaking			✓				
ACK/NAK			✓				
Two Digit Supplements		✓	✓	as code 39	✓	✓	✓
Five Digit Supplements		✓	✓	as code 39	✓	✓	✓
Bookland 978		✓	✓	as code 39	✓	✓	✓

DEFAULT SETTINGS

PARAMETER	DEFAULT	OCIA	RS232	LIGHT PEN	IBM 46XX	KBW	USB
Bookland 977 (2 digit) Supplemental Requirement		✓	✓	✓	✓	✓	✓
Supplements are not Required	*	✓	✓	✓	✓	✓	✓
Two Digit Redundancy	*	✓	✓	✓	✓	✓	✓
Five Digit Redundancy		✓	✓	✓	✓	✓	✓
100 msec to Find Supplement Configurable in 100 msec steps (MAX 800 msec)	*	✓	✓	✓	✓	✓	✓
Coupon Code 128		✓	✓	as code 39	✓	✓	✓
Configurable Code Lengths	7 avail.	✓	✓	✓	✓	✓	✓
Configurable Prefix Characters	10 avail.		✓			✓	✓
Suffix Characters			✓			✓	✓
Prefixes for individual Code Types			✓			✓	✓
Editing		✓	✓	✓	✓	✓	✓
Inter Scan-Code Delay Configurable (100 µsec steps)	800 µsec					✓	✓
Function/Control Key Support						✓	✓
Minimum Element Width Configurable in 5.6 µsec steps	1 msec			✓			
Depth of Field							
Variable Depth of Field	*	✓	✓	✓	✓	✓	✓
Normal Depth of Field	*	✓	✓	✓	✓	✓	✓
Extended Depth of Field		✓	✓	✓	✓	✓	✓
Long Depth of Field	*	✓	✓	✓	✓	✓	✓
Ultra Close Depth of Field		✓	✓	✓	✓	✓	✓

DEFAULT SETTINGS

Default settings for “Aux” interface

The secondary scanner and the MS7320 always communicate via RS232. Data is relayed to the host via various primary interfaces.

PARAMETER	DEFAULT	OCIA	RS232	LIGHT PEN	IBM 46XX	KBW	USB
Aux Baud Rate	38400	✓	✓	✓	✓	✓	✓
Aux parity	space	✓	✓	✓	✓	✓	✓
Aux data bits	7	✓	✓	✓	✓	✓	✓
Aux stop bits	2	✓	✓	✓	✓	✓	✓
Aux character RTS	*	✓	✓	✓	✓	✓	✓
Aux message RTS		✓	✓	✓	✓	✓	✓
Aux Ack/Nak	*	✓	✓	✓	✓	✓	✓
Aux Xon/Xoff	*	✓	✓	✓	✓	✓	✓
Aux D/E commands		✓	✓	✓	✓	✓	✓
Aux M/O commands		✓	✓	✓	✓	✓	✓
Aux F/L commands		✓	✓	✓	✓	✓	✓
Aux Intercharacter Delay	1 msec	✓	✓	✓	✓	✓	✓
Aux Port Data Format	None (Disabled)	✓	✓	✓	✓	✓	✓

Scanner Pinout Connections

The MS7320 scanner interfaces terminate to 10-pin modular jacks located on the back of the unit. The serial number label indicates the model number of the scanner.

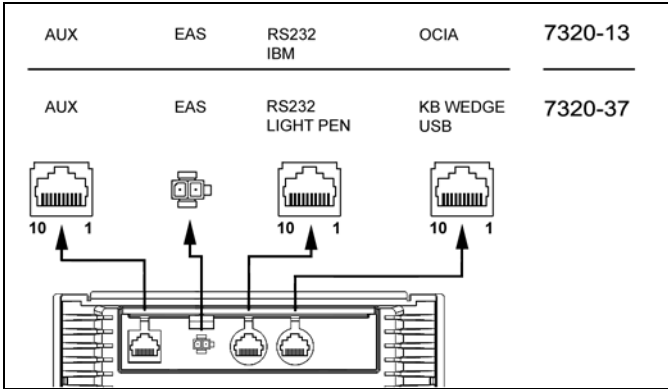

Figure 31: Scanner Interface Ports

MS732x-13 OCIA	
Pin	Function
1	Ground
2	NC
3	NC
4	RDAT A
5	RDAT A Return
6	Clock in
7	Clock out
8	Clock in Return/ Clock out Rtrn
9 +	5VDC
10	Shield Ground

MS732x-13 IBM 46xx	
Pin	Function
1	Ground
2	RS232 Transmit Output
3	RS232 Receive Input
4	RTS Output
5	CTS Input
6	DT R
7	IBM B- (D-)
8	IBM A+ (D+)
9 +	5V IN
10	NC

SCANNER AND CABLE TERMINATIONS

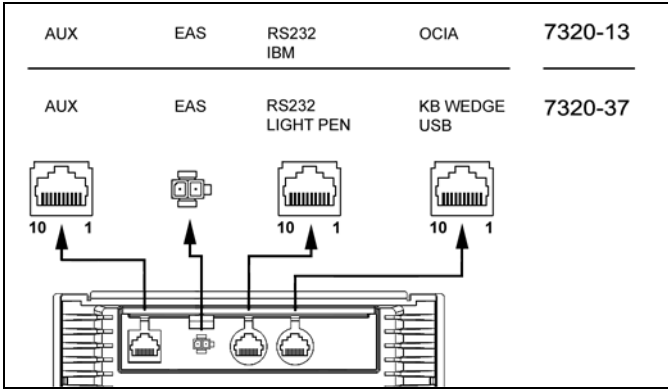

Figure 32: Scanner Interface Ports

MS732x-37 Keyboard Wedge, Stand-Alone Keyboard or USB	
Pin	Function
1	Ground
2	USB D-
3	USB D+
4	PC Data
5	PC Clock
6	KB Clock
7	PC +5V, V-USB
8	KB Data
9	+5VDC
10	Shield Ground

MS732x-37 RS232 or Light Pen	
Pin	Function
1	Ground
2	RS232 Transmit Output
3	RS232 Receive Input
4	RTS Output
5	CTS Input
6	DTR Input/LTPN Source
7	N/C
8	LT PN Data
9	+5VDC
10	Shield Ground

MS732x-13/-37 Auxiliary Port RS232 IN Only	
Pin	Function
1	Ground
2	RS232 Receive Input
3	RS232 Transmit Output
4	RTS In
5	CTS Out
6-10	NC

Cable Connector Configurations (Host End)

PowerLink Cable MLPN 59-59xxx*	
Pin	Function
1 Shield	Ground
2	RS232 Transmit Output
3	RS232 Receive Input
4 DT	R Input
5	Power/Signal Ground
6	Reserved
7 CT	S Input
8 RT	S Output
9	+5VDC

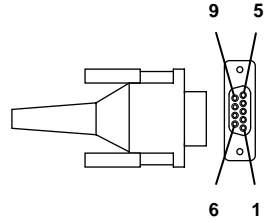

9-Pin D-Type Conn.

xxx* specifies connection to the host

USB PowerLink Cable MLPN 59-59165, Type A	
Pin	Function
1	N/C
2	D-
3	D+
4	Ground

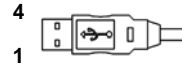

USB Type A (Top)
Locking Type A (Bottom)

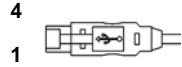

PowerLink, RS232 AUX Cable MLPN 54-54667	
Pin	Function
1	Ground
2	RS232 Transmit Output
3	RS232 Receive Input
4	RTS Output
5	CTS Input
6-10	N/C

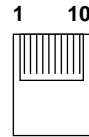

10-pin Modular Plug

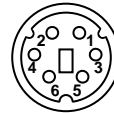

Stand Alone Keyboard Cable MLPN 59-59020	
Pin	Function
1	PC Data
2	NC
3	Power Ground
4	+5VDC PC Power to KB
5	PC Clock
6	NC





6-Pin Male Mini-DIN Conn.

SCANNER AND CABLE TERMINATIONS

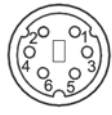
Cable Connector Configurations (Host End)

PowerLink, Keyboard Wedge MLPN 59-59002		
Pin	Function	 5-Pin DIN, Female
1 Key	board Clock	
2 Key	board Data	
3 No	Connect	
4 Pow	er Ground	
5	+5 Volts DC	
Pin	Function	 6-Pin DIN, Male
1 Key	board Data	
2 No	Connect	
3 Pow	er Ground	
4	+5 Volts DC	
5 PC	Clock	
6 No	Connect	

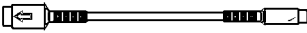
Metrologic will supply an adapter cable with a 5-pin DIN male connector on one end and a 6-pin mini DIN female connector on the other. According to the termination required, connect the appropriate end of the adapter cable to the PowerLink cable, leaving the necessary termination exposed for connecting to the keyboard and the keyboard port on the PC.

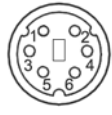
Keyboard Wedge Adapter Cable		
Pin	Function	 5-Pin DIN, Male
1 PC	Clock	
2 PC	Data	
3 No	Connect	
4 Pow	er Ground	
5	+5 Volts DC	
Pin	Function	 6-pin Mini DIN, Female
1 Key	board Data	
2 No	Connect	
3 Pow	er Ground	
4	+5 Volts DC	
5 Key	board Clock	
6 No	Connect	

LIMITED WARRANTY

The MS7320 InVista® Series scanners are manufactured by Metrologic at its Blackwood, New Jersey, U.S.A. facility. The MS7320 Series scanners have a three (3) year or two (2) year limited warranty from the date of manufacture. The duration of the warranty is dependent upon the country where the product was purchased. Please contact your Metrologic representative for warranty information. Metrologic warrants and represents that all MS7320 Series scanners are free of all defects in material, workmanship and design, and have been produced and labeled in compliance with all applicable U.S. Federal, state and local laws, regulations and ordinances pertaining to their production and labeling.

This warranty is limited to repair, replacement of product or refund of product price at the sole discretion of Metrologic. Faulty equipment must be returned to one of the following Metrologic repair facilities: Blackwood, New Jersey, USA; Madrid, Spain; or Suzhou, China. To do this, contact the appropriate Metrologic Customer Service/Repair Department to obtain a Returned Material Authorization (RMA) number.

In the event that it is determined the equipment failure is covered under this warranty, Metrologic shall, at its sole option, repair the Product or replace the Product with a functionally equivalent unit and return such repaired or replaced Product without charge for service or return freight, whether distributor, dealer/reseller, or retail consumer, or refund an amount equal to the original purchase price.

This limited warranty does not extend to any Product which, in the sole judgment of Metrologic, has been subjected to abuse, misuse, neglect, improper installation, or accident, nor any damage due to use or misuse produced from integration of the Product into any mechanical, electrical or computer system. The warranty is void if the case of Product is opened by anyone other than Metrologic's repair department or authorized repair centers.

THIS LIMITED WARRANTY, EXCEPT AS TO TITLE, IS IN LIEU OF ALL OTHER WARRANTIES OR GUARANTEES, EITHER EXPRESS OR IMPLIED, AND SPECIFICALLY EXCLUDES, WITHOUT LIMITATION, WARRANTIES OF MERCHANTABILITY AND FITNESS FOR A PARTICULAR PURPOSE UNDER THE UNIFORM COMMERCIAL CODE, OR ARISING OUT OF CUSTOM OR CONDUCT. THE RIGHTS AND REMEDIES PROVIDED HEREIN ARE EXCLUSIVE AND IN LIEU OF ANY OTHER RIGHTS OR REMEDIES. IN NO EVENT SHALL METROLOGIC BE LIABLE FOR ANY INDIRECT OR CONSEQUENTIAL DAMAGES, INCIDENTAL DAMAGES, DAMAGES TO PERSON OR PROPERTY, OR EFFECT ON BUSINESS OR PROPERTY, OR OTHER DAMAGES OR EXPENSES DUE DIRECTLY OR INDIRECTLY TO THE PRODUCT, EXCEPT AS STATED IN THIS WARRANTY. IN NO EVENT SHALL ANY LIABILITY OF METROLOGIC EXCEED THE ACTUAL AMOUNT PAID TO METROLOGIC FOR THE PRODUCT. METROLOGIC RESERVES THE RIGHT TO MAKE ANY CHANGES TO THE PRODUCT DESCRIBED HEREIN.

CORPORATE HEADQUARTERS, NORTH AMERICA

Metrologic Instruments, Inc.
90 Coles Rd.
Blackwood, NJ 08012-4683
Customer Service Department
Tel: 1-800-ID-METRO
Fax: 856-228-6673
Email: info@metrologic.com

METROLOGIC EUROPEAN REPAIR CENTER (MERC)

Metrologic Eria Ibérica, SL
C/Alfonso Gomez, 38-40, 1D
28037 Madrid
Tel: +34 913 751 249
Fax: +34 913 270 437

MTLG Auto ID INSTRUMENTS (SHANGHAI) Co., LTD Suzhou Sales Office

BLK A, Room# 03/03-04
No.5 Xinghan Street, Xinsu Industrial Square
China-Singapore Suahou Industrial Park, Suzhou, PRC
Tel: 86-512-67622550
Fax: 86-512-67622560
Email: info@cn.metrologic.com

SAFETY

ITE Equipment

IEC 60950-1; EN 60950-1

Laser

Laser Class 1: IEC 60825-1:1993+A1+A2, EN: 60825-1:1994+A1+A2



Caution

Use of controls or adjustments or performance of procedures other than those specified herein may result in hazardous laser light exposure. Under no circumstances should the customer attempt to service the laser scanner. Never attempt to look at the laser beam, even if the scanner appears to be nonfunctional. Never open the scanner in an attempt to look into the device. Doing so could result in hazardous laser light exposure. The use of optical instruments with the laser equipment will increase eye hazard.

Atención

La modificación de los procedimientos, o la utilización de controles o ajustes distintos de los especificados aquí, pueden provocar una luz de láser peligrosa. Bajo ninguna circunstancia el usuario deberá realizar el mantenimiento del láser del escáner. Ni intentar mirar al haz del láser incluso cuando este no esté operativo. Tampoco deberá abrir el escáner para examinar el aparato. El hacerlo puede conllevar una exposición peligrosa a la luz de láser. El uso de instrumentos ópticos con el equipo láser puede incrementar el riesgo para la vista.

Attention

L'emploi de commandes, réglages ou procédés autres que ceux décrits ici peut entraîner de graves irradiations. Le client ne doit en aucun cas essayer d'entretenir lui-même le scanner ou le laser. Ne regardez jamais directement le rayon laser, même si vous croyez que le scanner est inactif. N'ouvrez jamais le scanner pour regarder dans l'appareil. Ce faisant, vous vous exposez à un rayonnement laser qui est dangereux. L'emploi d'appareils optiques avec cet équipement laser augmente le risque d'endommagement de la vision.

SAFETY

Achtung

Die Verwendung anderer als der hier beschriebenen Steuerungen, Einstellungen oder Verfahren kann eine gefährliche Laserstrahlung hervorrufen. Der Kunde sollte unter keinen Umständen versuchen, den Laser-Scanner selbst zu warten. Sehen Sie niemals in den Laserstrahl, selbst wenn Sie glauben, daß der Scanner nicht aktiv ist. Öffnen Sie niemals den Scanner, um in das Gerät hineinzusehen. Wenn Sie dies tun, können Sie sich einer gefährlichen Laserstrahlung aussetzen. Der Einsatz optischer Geräte mit dieser Laserausrüstung erhöht das Risiko einer Sehschädigung.

Attenzione

L'utilizzo di sistemi di controllo, di regolazioni o di procedimenti diversi da quelli descritti nel presente Manuale può provocare delle esposizioni a raggi laser rischiose. Il cliente non deve assolutamente tentare di riparare egli stesso lo scanner laser. Non guardate mai il raggio laser, anche se credete che lo scanner non sia attivo. Non aprite mai lo scanner per guardare dentro l'apparecchio. Facendolo potete esporVi ad una esposizione laser rischiosa. L'uso di apparecchi ottici, equipaggiati con raggi laser, aumenta il rischio di danni alla vista.

EMC

Emissions: FCC Part 15, ICES-003, CISPR 22, EN 55022

Immunity: CISPR 24, EN 55024

Changes or modifications not expressly approved by the party responsible for compliance could void the user's authority to operate the equipment.

Class A Devices

The following is applicable when the scanner cable is greater in length than 3 meters (9.8 feet) when fully extended:

Les instructions ci-dessous s'appliquent aux cables de scanner dépassant 3 mètres (9.8 pieds) de long en extension maximale:

Folgendes trifft zu, wenn das Scannerkabel länger als 3 Meter ist:

This equipment has been tested and found to comply with limits for a Class A digital device, pursuant to part 15 of the FCC Rules. These limits are designed to provide reasonable protection against harmful interference when the equipment is operated in a commercial environment. This equipment generates, uses, and can radiate radio frequency energy and, if not installed and used in accordance with the instruction manual, may cause harmful interference to radio communications. Operation of this equipment in a residential area is likely to cause harmful interference, in which case the user will be required to correct the interference at their own expense. Any unauthorized changes or modifications to this equipment could void the user's authority to operate this device.

EMC

Class A Devices (Continued...)

This device complies with part 15 of the FCC Rules. Operation is subject to the following two conditions: (1) This device may not cause harmful interference, and (2) this device must accept any interference received, including interference that may cause undesired operation.

Notice

This Class A digital apparatus complies with Canadian ICES-003.

Remarque

Cet appareil numérique de la classe A, conformément à la norme NMB-003 du Canada.

European Standard

Warning

This is a class A product. In a domestic environment this product may cause radio interference in which case the user may be required to take adequate measures.

Funkstöreigenschaften nach EN55022:1998

Warnung!

Dies ist eine Einrichtung der Klasse A. Diese Einrichtung kann im Wohnbereich Funkstörungen verursachen. In diesem Fall kann vom Betreiber verlangt werden, angemessene Massnahmen durchzuführen.

Standard Europeo

Attenzione

Questo è un prodotto di classe A. Se usato in vicinanza di residenze private potrebbe causare interferenze radio che potrebbero richiedere all'utilizzatore opportune misure.

Attention

Ce produit est de classe "A". Dans un environnement domestique, ce produit peut être la cause d'interférences radio. Dans ce cas l'utilisateur peut être amené à prendre les mesures adéquates.

EMC

Changes or modifications not expressly approved by the party responsible for compliance could void the user's authority to operate the equipment.

Class B Devices

The following is applicable when the scanner cable is less than 3 meters (9.8 feet) in length when fully extended:

Les instructions ci-dessous s'appliquent aux câbles de scanner ne dépassant pas 3 mètres (9.8 pieds) de long en extension maximale:

Folgendes trifft zu, wenn das Scannerkabel kürzer als 3 Meter ist:

This device complies with Part 15 of the FCC Rules. Operation is subject to the following two conditions: (1) This device may not cause harmful interference, and (2) this device must accept any interference received, including interference that may cause undesired operation.

This equipment has been tested and found to comply with the limits for a Class B digital device, pursuant to Part 15 of the FCC rules. These limits are designed to provide reasonable protection against harmful interference in a residential installation. This equipment generates, uses, and can radiate radio frequency energy and, if not installed and used in accordance with the instructions, may cause harmful interference to radio communications. However, there is no guarantee that interference will not occur in a particular installation. If this equipment does cause harmful interference to radio or television reception, which can be determined by turning the equipment off and on, the user is encouraged to try to correct the interference by one or more of the following measures:

- Reorient or relocate the receiving antenna
- Increase the separation between the equipment and receiver
- Connect the equipment into an outlet on a circuit different from that to which the receiver is connected
- Consult the dealer or an experienced radio/TV technician for help

Notice

This Class B digital apparatus complies with Canadian ICES-003.

Avertissement

Cet appareil numérique de la class B est conforme à la norme NMB-003.

PATENTS

For patent information, please refer to www.honeywellaidc.com/patents.

INDEX

A

Accessories 2
Adapter 49
Auxiliary 2, 33, 45, 47, 48
 Scanner 11, 12, 13

B

Bar Code 38
Beep 17–19, 29–33, 39, 41
Button 14, 20, 21, 39

C

Cable 8, 14
 Adapter 49
 Area 14
 Auxiliary 2
 Communication 2, 46–49
 Cover 14, 15
 EAS 2, 28
 Keyboard Wedge 46–49
 MVC 2
 Pin Assignments 46–49
 Power Supply 3
 PowerLink 2, 46–49
 Termination 34
 USB 2, 46–49
Caution 16, 51
CE 51

Class

 Class 1 Laser 51
 Class A Device 52, 53
 Class B Device 54
Communication 37, 41
Configuration 38, 39
Customer Service 3, 50

D

Default Settings 40–45
Depth of Field 23, 24
 Extended 44
 Normal 44
Dip Switch 14

E

EAS 2, 28

F

Face Plate 15
Firmware 39
Flash ROM 39

G

Green LED 14, 17–19, 29, 34

H

HID 7
Host 11

I

IBM 10, 40–45, 46
Indicator
 Audible 14, 17, 29–33, 34, 39
 Failure 19
 Visual 14, 18, 29–33, 34, 39
Input Voltage 35
Interface
 IBM 10, 34, 40–45
 Keyboard Wedge 5, 34, 40–45
 Light Pen 8, 9, 34, 40–45
 OCIA 4, 34, 40–45
 RS232 8, 9, 34, 40–45
 Stand-Alone Keyboard 6, 34
 USB 7, 34, 40–45, 40–45

K

Keyboard Type 37
Keyboard Wedge 1, 2, 5, 31, 37,
 40–45, 47, 49

L

Labels 16
Laser 16, 20, 21
LED 14, 17–19, 29–33, 34
 Green 14, 17–19, 29, 34
 Red 14, 17–19, 30, 34
Light Levels 35
Light Pen 1, 8, 9, 37, 47
Light Source 34

INDEX

M

Maintenance 14
Manual 2, 37
MetroSelect 38
MetroSet2 39
Min Bar Width 34
Multi-Function Button 14, 20, 21
MVC 2

N

Notices 51, 53, 54

O

OCIA 4, 40–45, 46
Operating Current 35
Operation 51, 53, 54

P

Patents 55
Pedestal Base 3
Pin Assignments
 Cable 46–49
Port 45
POS 7
Power 39
Power Save 20, 21
Power Supply 3
Protocols 37

R

Razzberry Tone 17, 19, 41
Red LED 14, 17–19, 30, 34
Regulatory Compliance 51–54
Repair 50

RS232 9, 32, 36, 40–45, 47, 48

S

Safety 51, 53, 54
Scan Lines 34
Scan Pattern 34
Scan Speed 34
Scan Volume 22
Specification
 Electrical 35
 Mechanical 34
 Operation 34
Stand 3, 25–27, 34
Stand-Alone Keyboard .. 2, 6, 47, 48
Storage 35

T

Tone 17, 21
Transformer 3
Transformers 35
Troubleshooting 29–33

U

Upgrade 39
USB 2, 7, 33, 40–45, 47, 48

V

Ventilation 35

W

Warranty 50
Weight 34
Window 3, 14, 15, 16
Window Face Plate 14

WORLDWIDE HEADQUARTERS

Metrologic Instruments, Inc.

90 Coles Rd. Blackwood, NJ 08012-4683 • Email: info@metrologic.com
Customer Service Tel: 1-800-ID-METRO • Corporate Tel: 856-228-8100
Fax: 856-228-6673 (Sales) • 856-228-1879 (Marketing) • Fax: 856-228-0653 (Legal/Finance)

USA

Omniplanar

Tel: 856.537.6100
Fax: 856.537.6116
Email: info@omniplanar.com

USA

NOVODisplay

Tel: 856.537.6139
Fax: 856.537.6116
Email: info@NOVOdisplay.com

METROLOGIC - THE AMERICAS

USA

Metrologic USA - Headquarters

Tel: 1.856.537.6400
Fax: 1.856.537.6474
Email: info@us.metrologic.com

Mexico

Metrologic Mexico, S.A. DE C.V.

Tel: 55.5365.6247
Fax: 55.5362.2544
Email:
info@mx.metrologic.com

South America

Metrologic do Brasil Ltda.

Tel: 52.55.11.5182.7273
Fax: 52.55.11.5182.7198
Email: info@sa.metrologic.com

South America

Metrologic South America

Tel: 1.239.642.1958
Fax: 1.239.642.1959
Email: info@sa.metrologic.com

METROLOGIC - EMEA

Central Europe

Metrologic Instruments GmbH Headquarters

Tel: 49-89-89019-0
Fax: 49-89-89019-200
Email: info@de.metrologic.com

France

Metrologic Eria France SA

Tel: +33 (0) 1 48.63.78.78
Fax: +33 (0) 1 48.63.24.94
Email: info@fr.metrologic.com

METROLOGIC - EMEA

Spain

Metrologic Eria Iberica, SL
Tel: +34 913 272 400
Fax: +34 913 273 829
Email: info@es.metrologic.com

Russia

Metrologic Instruments LLC

Tel: +7 (495) 737 7273
Fax: +7 (495) 737 7271
Email: info@ru.metrologic.com

Italy

Metrologic Instruments Italia

Tel: +39 0 57 6511978 or
+39 051 651 1978
Fax: +39 0 51 6521337
Email: info@it.metrologic.com

Poland

Metrologic Instruments Poland

Tel: +48 (22) 545 04 30
Fax: +48 (22) 545 04 31
Email: info@pl.metrologic.com

United Kingdom

Metrologic Instruments UK Limited

Tel: +44 (0) 1256 365900
Fax: +44 (0) 1256 365955
Email: info@uk.metrologic.com

METROLOGIC - APAC

Asia

Metrologic Asia (Pte) Ltd Headquarters

Tel: (65) 6842-7155
Fax: (65) 6842-7166
Email: info@sg.metrologic.com

China

Suzhou Sales Office Headquarters

Tel: 86-512-67622550
Fax: 86-512-67622560
Email: info@cn.metrologic.com

METROLOGIC - APAC

Australia

Metrologic Australia
Tel: 61 2 9652 2726
(international)
Tel: 02 9816 6470 (local)
Tel: 1 800 99 88 38 (Australia)
Email:
kmason@au.metrologic.com

China

Beijing Sales Office
Tel/Fax: 86 10 82253472
Email: info@cn.metrologic.com

China

Chengdu Sales Office
Tel/Fax: 86 28 86200109
Email: info@cn.metrologic.com

China

Guangzhou Sales Office
Tel: 86-20-38823476
Fax: 86-20-38823477
Email: info@cn.metrologic.com

India

India Sales Office
Tel: +91 80 41256718
Fax: +91 80 41256719
Email: info@in.metrologic.com

Korea

Korea Sales Office
Tel: 82-2-6205-5379
Fax: 82-2-3444-3980
Email:
Scott.lee@kr.metrologic.com

Japan

Metrologic Japan Co., Ltd.
Tel: 81-3-3839-8511
Fax: 81-3-3839-8519
Email: info@jp.metrologic.com

Thailand

Metrologic Thailand
Tel: +662-610-3787
Fax: +662-610-3601
Email:
tawan.jandang@th.metrologic.com

China

Shanghai
Tel: 86-21-58356616
Fax: 86-21-58358873
Email: info@cn.metrologic.com

January 2008

Printed in the USA



00 - 02896G