

This gas grill must be used only outdoors in a well-ventilated space and must not be used inside a building, garage, screened-in porch, gazebo or any other enclosed area.

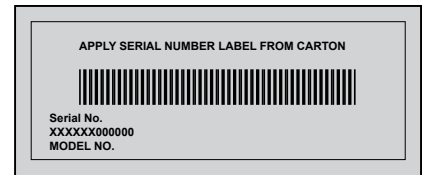

LD485RSIB



DO NOT RETURN TO PLACE OF PURCHASE. PLEASE CONTACT 1-866-820-8686 FOR ASSISTANCE. WE CAN HELP WITH DAMAGED OR MISSING PARTS, ASSEMBLY AND OPERATION QUESTIONS.



DANGER

IF YOU SMELL GAS:

- Shut off gas to the appliance.
- Extinguish any open flame.
- Open lid.
- If odor continues, keep away from the appliance and immediately call your gas supplier or fire department.



WARNING

Do not try to light this appliance without reading the "LIGHTING" instructions section of this manual.

Do not store or use gasoline or other flammable liquids or vapors in the vicinity of this or any other appliance. An L.P. cylinder not connected for use must not be stored in the vicinity of this or any other appliance. If the information in these instructions is not followed exactly, a fire or explosion may result, causing property damage, personal injury or death.

Notice to Installer: Leave these instructions with the grill owner for future reference.



Napoleon Appliance Corp.,
214 Bayview Dr, Barrie, Ontario, Canada L4N 4Y8 Phone: 1-866-820-8686
Fax: (705)725-2564 email: wecare@napoleonproducts.com web site: www.napoleongrills.com

THANK YOU FOR CHOOSING NAPOLEON

NAPOLEON products are designed with superior components and materials, and are assembled by trained craftsmen who take great pride in their work. The burner and valve assembly are leak tested and test-fired at a quality test station. This grill has been thoroughly inspected by a qualified technician before packaging and shipping to ensure that you, the customer, receive the quality product you expect from NAPOLEON.

We at Napoleon are dedicated to you, "our valued customer." It is our goal to provide you with the necessary tools for an unforgettable grilling experience. This manual is provided to assist you in assuring your new grill is assembled, installed, maintained and cared for properly. It is important to read and understand this entire manual before operating your new grill to ensure you fully understand all the safety precautions and features your grill has to offer. By carefully following these instructions, you will enjoy years of trouble-free grilling. If this product fails to meet your expectations, for any reason, please call our customer care department at 1-866-820-8686 between 9 AM and 5 PM (Eastern Standard Time) or visit our Website at www.napoleongrills.com.

Napoleon Gas Grill President's Limited Warranty

NAPOLEON warrants the following materials and workmanship in your new NAPOLEON gas grill against defects for twenty five years. This covers aluminum castings (excluding paint), LUXIDIO® trays, stainless steel side shelves, stainless steel control panel (excluding screen printing), stainless steel burners, stainless steel or porcelain lid inserts, and lid handles, subject to the following conditions: During the first five years NAPOLEON will provide replacement parts at our option free of charge. From the sixth year to 25years, NAPOLEON will provide replacement parts at 50% of the current retail price.

Components such as stainless steel sear plates, stainless steel or cast iron cooking grids, valves with ignition system, temperature gauges, knobs, and ceramic infrared burners (excluding screens) are covered and Napoleon will provide parts free of charge during the first two years of the limited warranty.

All other components including regulators, casters, warming racks, hoses and connectors, I-GLOW™, fasteners and accessories are covered and NAPOLEON will provide parts free of charge during the first year of the limited warranty.

NAPOLEON shall not be liable for any transportation charges, labor costs or export duties.

Conditions And Limitations

"NAPOLEON warrants its products against manufacturing defects to the original purchaser only, provided that the purchase was made through an authorized NAPOLEON dealer and is subject to the following conditions and limitations:"

This factory warranty is non-transferable and may not be extended what-so-ever by any of our representatives.

The gas grill must be installed by a licensed, authorized service technician or contractor. Installation must be done in accordance with the installation instructions included with the product and all local and national building and fire codes.

This limited warranty does not cover damages caused by misuse, lack of maintenance, grease fires, hostile environments, accident, alterations, abuse or neglect and parts installed from other manufacturers will nullify this warranty.

This limited warranty further does not cover any scratches, dents, painted finishes, corrosion or discoloring by heat, abrasive and chemical cleaners, nor chipping on porcelain enamel parts, nor any components used in the installation of the gas grill.

Should deterioration of parts occur to the degree of non-performance within the duration of the warranted coverage, a replacement part will be provided.

In the first year only, this warranty extends to the replacement of warranted parts, which are defective in material or workmanship provided that the product has been operated in accordance with the operation instructions and under normal conditions.

After the first year, with respect to this President's Limited Lifetime Warranty NAPOLEON may, at its discretion, fully discharge all obligations with respect to this warranty by refunding to the original warranted purchaser the wholesale price of any warranted but defective part(s).

NAPOLEON will not be responsible for the installation, labor or any other costs or expenses related to the re-installation of a warranted part, and such expenses are not covered by this warranty.

Notwithstanding any provision contained in this President's Limited Lifetime Warranty NAPOLEON's responsibility under this warranty is defined as above and it shall not in any event extend to any incidental, consequential, or indirect damages.

This warranty defines the obligation and liability of NAPOLEON with respect to the NAPOLEON gas grill and any other warranties expressed or implied with respect to this product, its components or accessories are excluded.

NAPOLEON neither assumes, nor authorizes any third party to assume, on its behalf, any other liabilities with respect to the sale of this product.

NAPOLEON will not be responsible for: over firing, blow outs caused by environmental conditions such as strong winds, or inadequate ventilation,

Any damages to the gas grill due to weather damage, hail, rough handling, damaging chemicals or cleaners will not be the responsibility of NAPOLEON.

The bill of sale or copy will be required together with a serial number and a model number when making any warranty claims from NAPOLEON.

NAPOLEON reserves the right to have its representative inspect any product or part prior to honoring any warranty claim.

NAPOLEON shall not be liable for any transportation charges, labor costs, or export duties.



WARNING! Failure to follow these instructions could result in property damage, personal injury or death. Read and follow all warnings and instructions in this manual prior to operating grill.

Safe Operating Practices

- This gas grill must be assembled exactly according to the instructions in the manual. If the grill was store assembled, you must review the assembly instructions to confirm correct assembly and perform the required leak tests before operating the grill.
- Read the entire instruction manual before operating the gas grill.
- Under no circumstance should this gas grill be modified.
- Follow lighting instructions carefully when operating grill.
- Gas must be turned off at the propane cylinder or at the natural gas supply valve when the gas grill is not in use.
- Keep children and pets away from hot grill, DO NOT allow children to climb inside cabinet.
- Do not leave the grill unattended while in use.
- Do not move grill when hot or operating.
- This gas grill must not be installed in or on recreational vehicles and/or boats.
- This gas grill must only be stored outdoors in a well-ventilated area and must not be used inside a building, garage, screened -in porch or any other enclosed area.
- Maintain proper clearance to combustibles (16" (410mm) to rear of unit 7" (178mm) to sides). Additional clearance 24" (610mm) is recommended near vinyl siding or panes of glass.
- At all times keep the ventilation openings of the cylinder enclosure free and clear from debris.
- Do not operate unit under any combustible construction.
- Do not locate in windy settings. High winds adversely affect the cooking performance of the gas grill.
- When the gas grill is stored indoors, the propane cylinder must be disconnected from the grill and stored outdoors in a well-ventilated area, disconnected cylinders must not be stored in a building, garage or other enclosed area. Natural gas units must be disconnected from the supply when being stored indoors.
- Inspect the gas line hose before each use. If there is evidence of excessive abrasion or wear, it must be replaced before using the gas grill, with a replacement hose assembly specified by the grill manufacturer.
- Never store a spare LP gas cylinder under or near this grill.
- Never fill the cylinder beyond 80 % full.
- Do not attempt to use a cylinder, which is not equipped with a QCC1 type connection.
- Leak test all connections before initial use, even if the grill was purchased fully assembled, annually or whenever any gas component has been replaced.
- Never use natural gas in a unit designed for liquid propane gas.
- Never use lighter fluid in a gas grill.
- Use charcoal briquettes only with a Napoleon charcoal tray designed for this unit.
- Burner controls must be off when turning supply cylinder on.
- Do not light burners with lid closed.
- Do not operate rear burner with main burners operating.
- The lid is to be closed during the preheat period.
- Do not route hose underneath drip pan-proper hose clearance to bottom of unit must be maintained.
- Clean grease tray and sear plates regularly to avoid build-up, which may lead to grease fires.
- Remove warming rack before lighting rear burner. The extreme heat will damage the warming rack.
- Ensure sear plates are positioned properly according to sear plate installation instructions.
- Do not use side shelves to store lighters, matches or any other combustibles.
- Keep gas line away from heated surfaces
- Keep any electrical supply cord away from water or heated surfaces.
- Inspect infrared burner venturi tube for spider webs and other obstructions periodically. Clean the tubes completely if you find any such obstructions.
- The outdoor cooking gas grill and its individual shutoff valve must be disconnected from the gas supply piping system during any pressure testing of that system at test pressures in excess of 0.5psi (3.5kPa).
- The outdoor cooking gas grill must be isolated from the gas supply piping system by closing its individual manual shutoff valve during any pressure testing of the gas supply piping system at test pressures equal to or less than 1/2 psi (3.5 kPa).

Cylinder Specification/Gas Hook Up

THIS GAS BARBECUE IS CERTIFIED UNDER CANADIAN AND AMERICAN NATIONAL STANDARDS, CAN/CSA-1.6-2005 AND ANSI Z21.58 -2005 RESPECTIVELY FOR OUTDOOR GAS GRILLS AND SHOULD BE INSTALLED TO CONFORM WITH LOCAL CODES. In absence of local codes, install to the current CAN/CGA-B149.1 Propane Installation Code in Canada or to the National Fuel Gas Code, NFPA54/ANSI Z223.1 in the United States.

If a rotisserie motor is used, it must be electrically grounded in accordance with local codes or, in absence of local codes, with the current CSA C22.1 Canadian electrical code in Canada or the National Electrical Code, ANSI/NFPA 70 in the United States.

California Proposition 65: The burning of gas fuel creates by-products, some of which are on the list as substances known by the State of California to cause cancer or reproductive harm. When cooking with gas, always ensure adequate ventilation to the unit, to minimize exposure to such substances.

Propane Cylinder Specifications



WARNING! If these instructions are not followed exactly, a fire causing death or serious injury may occur.

A dented or rusty cylinder may be hazardous and should be checked by your propane supplier. Never use a cylinder with a damaged valve. Use only a propane supply cylinder constructed and marked in accordance with the specifications for LP-gas cylinders of the National Standard of Canada, CAN/CSA-b339, Cylinders, Spheres and Tubes for Transportation of Dangerous Goods; and Commission, as applicable or the Specifications for LP-Gas Cylinders of the U.S. Department of Transportation (D.O.T.). This appliance has been designed for use with a 20 lb. (9.1 kg) size propane cylinder only (not supplied).

The propane cylinder must be provided with a cylinder connection device compatible with the connection for outdoor cooking appliances. The propane cylinder must be provided with a shut-off valve terminating in a propane cylinder valve type QCC1, and a safety relief device having direct communication with the vapor space of the cylinder. The cylinder supply system must be arranged for vapor withdrawal and the cylinder shall include a collar to protect the cylinder valve. The cylinder shall incorporate a listed OPD (overfill protection device). Do not store a spare LP-gas cylinder under or near this appliance. Never fill the cylinder beyond 80 percent full.

Propane Cylinder Installation

Cylinder Connection: Ensure that the gas regulator hose is kink free. Remove the cap or plug from the cylinder fuel valve. Insert the black QCC1 regulator nipple onto the QCC1 fuel valve. Hand tighten clockwise. Do not use tools. Leak test all joints prior to using the barbecue. A leak test must be performed annually, and each time a cylinder is hooked up, or if a part of the gas system is replaced.

- Check that the cylinder valve is closed by turning the knob clockwise.
- Check that the grill's burner knobs are in the off position.
- Open cabinet doors.
- Place the cylinder into the tank holder in bottom of shelf.
- Position the cylinder so that the valve faces toward the front of the unit.
- Attach regulator hose.



WARNING! Use only the pressure regulator and hose assembly provided with this barbecue. Replacement pressure regulators and hose assemblies must be specified by the manufacturer. Do not store a spare propane cylinder on the shelf beneath the barbecue. The regulator must be attached so that no part of the hose touches the underside of the grill or drippan. A fire will result if these directions are ignored.

The regulator supplies a pressure of 11 inches. water column to the gas grill and has a QCC1 type fitting. Cylinders to be used with this unit must be supplied with a QCC1 cylinder valve. A QCC1 cylinder has a positive seating connection, which will not allow gas flow until a positive seal has been achieved. It is also equipped with an excess flow device. In order to attain full flow to the grill, the valves must be in the off position when the cylinder valve is turned on.

Natural Gas Hook-Up

This natural gas grill is supplied with a 10ft supply hose (complete with a quick disconnect) designed for natural gas and certified for outdoor use. The gas grill is designed to operate at an inlet pressure of 7 inches water column. Piping and valves upstream of the quick disconnect are not supplied. The installation must comply with CAN B149.1 Natural Gas and Propane installation code in Canada, or to the National Fuel Gas Code, ANSI Z223.1 in the United States. The gas supply pipe must be sufficiently sized to supply the BTU/h specified on the rating plate, based on the length of the piping run.

The quick disconnect must not be installed in an upward direction and a readily accessible manual shut-off valve must be installed upstream of, and as close to, the quick disconnect as is feasible. The flared end of the hose must be connected to the fitting on the end of the flex tube as illustrated in the *Natural Gas Hose Attachment* diagram. Tighten using two wrenches. (*Do not use thread sealer/pipe dope.*) These connections must be made by a licensed gas installer. Leak test all joints prior to using the gas grill.



WARNING!

- The installation must be performed by a licensed gas fitter, and all connections must be leak tested before operating the grill.
- Do not route hose underneath drip pan.
- Do not route hose between space in bottom shelf and back panel.
- Do not route hose over top of back panel.
- Ensure all hose connections are tightened using two wrenches. Do not use teflon tape or pipe dope on any hose connection.
- Ensure the hose does not contact any high temperature surfaces, or it may melt and leak causing a fire.
- Do not use enclosure to store excess hose, as there is a greater chance of the hose contacting a hot surface, it may melt and leak causing a fire.
- Leak test all the connections using a soap and water solution, as per the leak testing instructions found in the this manual.

Leak Testing Instructions



WARNING! A leak test must be performed annually and each time a cylinder is hooked up or if a part of the gas system is replaced.



WARNING! Never use an open flame to check for gas leaks. Be certain no sparks or open flames are in the area while you check for leaks. Sparks or open flames will result in a fire or explosion, damage to property, serious bodily injury, or death.



Leak testing: This must be done before initial use, annually, and whenever any gas components are replaced or serviced. Do not smoke while performing this test, and remove all sources of ignition. See Leak Testing Diagram for areas to check. Turn all burner controls to the off position. Turn gas supply valve on.



Brush a half-and-half solution of liquid soap and water onto all joints and connections of the regulator, hose, manifolds and valves.

Bubbles will indicate a gas leak. Either tighten the loose joint or have the part replaced with one recommended by the Napoleon Customer Care department and have the grill inspected by a certified gas installer.



If the leak cannot be stopped, immediately shut off the gas supply, disconnect it, and have the grill inspected by a certified gas installer or dealer. Do not use the grill until the leak has been corrected.

Lighting Instructions

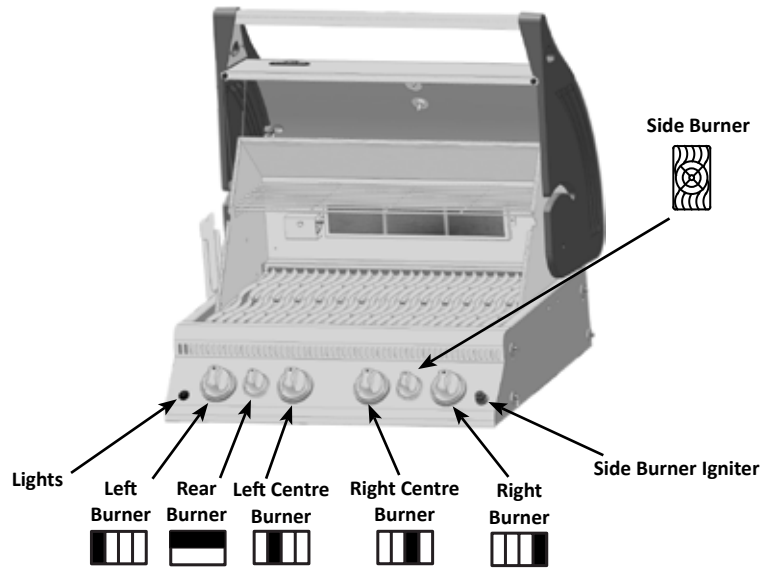

WARNING! Open lid

WARNING! Ensure all burner controls are in the off position. Turn on the gas supply valve.

Off Position 

Main Tube Burner Lighting	Rear Burner Lighting (Rotisserie Burner)	Side Burner Lighting (If equipped)
1. Open grill lid.	1. Open grill lid.	1. Open side burner cover.
2. Push and turn any main burner knob slowly to the 'hi' position. This action will ignite the pilot flame which will in turn light the selected burner. If the pilot lights, continue to push down on the control knob until the burner lights and then release.	2. Remove the warming rack	2. Push and turn side burner control to high position.
3. If the pilot does not ignite, then immediately turn the control knob back to the 'off' position and repeat step 1 several times.	3. Push and turn the rotisserie burner control knob slowly to the 'hi' position. This action will ignite the pilot flame which will in turn light the burner. If the pilot lights, continue to push down on the burner control knob until the burner lights then release.	3. Press and hold igniter button until burner lights, or light by match
4. If the pilot and burner will not ignite within 5 seconds, turn the control knob to the 'off' position and wait 5 minutes for any excess gas to dissipate. Either repeat steps 1 and 2 or light with a match.	4. If the burner does not ignite, then immediately turn the control knob back to the 'off' position and repeat step 2 several times.	4. If the burner will not ignite within 5 seconds, turn the control knob to the 'off' position and wait 5 minutes for any excess gas to dissipate. Either repeat steps 2 and 3 or light with a match.
	5. If the burner will not ignite within 5 seconds, turn the control knob to the 'off' position And wait 5 minutes for any excess gas to dissipate. Either repeat steps 2 and 3 or light with a match.	



WARNING! The propane cylinder is equipped with an excess flow device. Unless all burners are turned off prior to turning the cylinder on, only small flames and low heat will be achievable.

WARNING! Do not use the rear burner (rotisserie burner) with the main burners operating.

WARNING! If lighting the unit with a match, clip the match into the supplied lighting rod. Hold the lit match down through the grill and sear plate while turning the corresponding burner valve to high.



Operating The Grill

Initial Lighting: When lit for the first time, the gas grill emits a slight odor. This is a normal temporary condition caused by the “burn-in” of internal paints and lubricants used in the manufacturing process and does not occur again. Simply run the main burners on high for approximately one-half hour.

Main Burner Use: When searing foods, we recommend preheating the grill by operating all main burners in the high position with the lid closed for approximately 10 minutes. Food cooked for short periods of time (fish, vegetables) can be grilled with the lid open. Cooking with the lid closed will ensure higher, more even temperatures that can reduce cooking time and cook meat more evenly. Food that has a cooking time longer than 30 minutes, such as roasts, can be cooked indirectly (with the burner lit opposite to the food placement). When cooking very lean meats, such as chicken breasts or lean pork, the grids can be oiled before pre-heating to reduce sticking. Cooking meat with a high degree of fat content can create flare-ups. Either trim the fat or reduce temperatures to inhibit this. Should a flare-up occur, move food away from the flames and reduce the heat. Leave the lid open. See Your All Season Grill cookbook by Napoleon for more detailed instructions.

Direct Cooking: Place food to be cooked on the grill directly over the heat. This method is generally used for searing or for foods that do not require prolonged cooking times such as hamburgers, steaks, chicken pieces, or vegetables. The food is first seared to trap-in the juices and flavor, and then the temperature is lowered to finish cooking the food to your preference.

Indirect Cooking: With one or more burners operating, place food to be cooked on the grill over a burner that is not operating. The heat circulates around the food, cooking slowly and evenly. Cooking with this method is much the same as cooking in your oven and is generally used for larger cuts of meats such as roasts, chickens or turkeys, but can also be used for cooking foods that are prone to flare-ups or for smoking foods. Lower temperatures and slower cooking times result in tender foods.

Rear Burner Use (If Equipped): Remove the warming rack prior to use. Cooking grids should also be removed if they interfere with the rotisserie. The rear burner is designed to be used in conjunction with the rotisserie kit (included with most rear burner units) available from your dealer. See the rotisserie kit assembly instructions.

To use the counterbalance - remove the rotisserie motor from the gas grill. Place the spit with meat being cooked across the hangers inside the grill. The meat will naturally hang with the heavy side down. Tighten the counterbalance arm and weight so the arm is facing up. Slide the counterweight in or out to balance the load and tighten in place. Re-install the motor and begin cooking. Place a metal dish underneath the meat to collect drippings for basting and naturally delicious gravy. Basting liquid may be added as required. To seal in juices, first operate rear burner on high until brown, then reduce the heat to thoroughly cook foods. Keep the lid closed for best results. Your roasts and fowl will brown perfectly on the outside and stay moist and tender on the inside. For example, a 3 pound chicken on the rotisserie will be done in approximately 1½ hours on medium to high. See ‘Your all Season Grill’ cookbook by Napoleon for more detailed instructions.



WARNING! Barbecue sauce and salt can be corrosive and will cause rapid deterioration of the gas grill components unless cleaned regularly. When finished cooking disassemble rotisserie components, wash thoroughly with warm soapy water and store indoors.

Infrared Side Burner Use(if equipped): The gas grill should be located so that the side burner is protected from the wind, because the wind will adversely affect its performance.

The side burner is equipped with a cast iron cooking grid which can be positioned at two different heights. The lower position can be used like any range top burner, for gravies, soups, etc. The higher position is for searing meats. (see instructions located on side burner lid).



WARNING! Do not close the side burner lid while it is operating or hot.

WARNING! Do not adjust cooking grid while hot or operating.

WARNING! Do not use side burner to deep fry foods as cooking with oil can create a dangerous situation.

1. Follow the infrared side burner lighting instructions and operate on high for 5 minutes with the lid opened or until the ceramic burners glow red.
2. Place food on grills and cook according to times listed in the Infrared Grilling Chart.
3. Depending upon your taste, continue cooking over infrared burners on high, medium or low, turning food frequently, or place food on the main burner area of the grill, close lid, and allow oven temperature to slowly finish cooking your food.

CAUTION! Due to the intense heat the infrared burners provide, food left unattended over burners will burn quickly. Keep the lid open when cooking with the infrared burners on high. The intense heat ensures adequate searing temperatures even with the lid open. This also allows observation of the food, so as to prevent burning.

Protection Of Your Infra Red Burners: The infrared burners of your grill are designed to provide a long service life. However, there are steps you must take to prevent cracking of their ceramic surfaces, which will cause the burners to malfunction.

- Never let water come in direct contact with your ceramic burner.
- Do not allow hard objects to impact the infra red burner.
- Do not allow cold water (rain, sprinkler, hose, etc.) to come in contact with hot ceramic burners. A large temperature differential can cause cracking of the ceramic tile.

Damage caused by failure to follow these steps is not covered by your grill warranty.

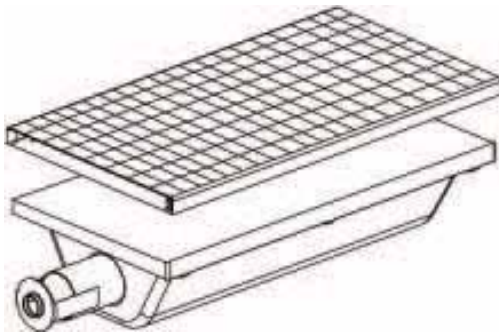

REPLACEMENT SCREEN N565-0002

Infrared Heat

Most people don't realize that the heat source we are most familiar with, our sun, warms the earth using mainly infrared energy. This is a form of electro-magnetic energy with a wavelength just greater than the red end of the visible light spectrum but less than a radio wave. This energy was discovered in 1800 by Sir William Herschel who dispersed sunlight into its component colors using a prism. He showed that most of the heat in the beam fell into the spectral region just beyond the red end of the spectrum, where no visible light existed. Most materials readily absorb infrared energy in a wide range of wavelengths, causing an increase in its temperature. The same phenomenon causes us to feel warmth when we are exposed to sunlight. The infrared rays from the sun travel through the vacuum of space, through the atmosphere, and penetrate our skin. This causes increased molecular activity in the skin, which creates internal friction and generates heat, allowing us to feel warmth.

Foods cooked over infrared heat sources are heated by the same principle. Charcoal grilling is our most familiar choice for infrared cooking. The glowing briquettes emit infrared energy to the food being cooked with very little drying effect. Any juices or oils that escape from the food drip onto the charcoal and vaporize into smoke giving the food its delicious grilled taste. The Napoleon infrared burner cooks in the same way. In each burner, 10,000 ports – each with its own tiny flame – cause the surface of the ceramic tile to glow red. This glow emits the same type of infrared heat to the food as charcoal, without its hassle or mess. Infrared burners also provide a more consistently heated area that is far easier to regulate than a charcoal fire. For instant searing, the burners can be set to high, yet they can also be turned down for slower cooking. We all know how difficult that is on a charcoal fire. Traditional gas burners heat the food in a different way. The air surrounding the burner is heated by the combustion process and then rises to the food being cooked. This generates lower grill temperatures that are ideal for more delicate cuisine such as seafood or vegetables, whereas Napoleon's infrared burners produce searing heat for juicier, tastier steaks, hamburgers and other meats. For cooking times and tips refer to the Infrared Grilling Chart.

Infrared Grilling Chart

Food	Control Setting	Cooking Time	Helpful Suggestions
Steak 1 in. thick	High setting 2 min. each side. High setting 2 min. each side then medium setting. High setting 2 min. each side then medium setting.	4 min. – Rare 6 min. – Medium 8 min. – Well done	When selecting meat for grilling, ask for marbled fat distribution. The fat acts as a natural tenderizer while cooking and keeps it moist and juicy.
Hamburger 1/2 in. thick	High setting 2 min. each side. High setting 2 1/2 min. each side. High setting 3 min. each side.	4 min. – Rare 5 min. – Medium 6 min. – Well done	Preparing hamburgers to order is made easier by varying the thickness of your patties. To add an exotic taste to your meat, try adding hickory-flavored woodchips to Napoleon's woodchip smoker.
Chicken pieces	High setting 2 min. each side. then medium-low to low setting.	20-25 min.	The joint connecting the thigh and the leg from the skinless side should be sliced 3/4 of the way though for the meat to lay flatter on the grill. This helps it to cook faster and more evenly. To add a trademark taste to your cooking, try adding mesquite-flavoured woodchips to your Napoleon woodchip smoker.
Pork chops	Medium	6 min. per side	Trim off the excess fat before grilling. Choose thicker chops for more tender results.
Spare ribs	High setting for 5 minutes low to finish	20 min. per side turn often	Choose ribs that are lean and meaty. Grill until meat easily pulls away from the bone.
Lamb chops	High setting for 5 minutes medium to finish	15 min. per side	Trim off the excess fat before grilling. Choose extra thick chops for more tender results.
Hot dogs	Medium - Low	4-6 min.	Select the larger size wieners. Slit the skin lengthwise before grilling.

Maintenance / Cleaning Instructions

We recommend this gas grill be thoroughly inspected and serviced annually by a qualified service person.



WARNING! Always wear protective gloves and safety glasses when cleaning your grill.



WARNING! To avoid the possibility of burns, maintenance should be done only when the grill is cool. Avoid unprotected contact with hot surfaces. Ensure all burners are turned off. Clean grill in an area where cleaning solutions will not harm decks, lawns, or patios. Do not use oven cleaner to clean any part of this gas grill. Do not use a self-cleaning oven to clean cooking grids or any other parts of the gas grill. Barbecue sauce and salt can be corrosive and will cause rapid deterioration of the gas grill components unless cleaned regularly.



Note: Stainless steel tends to oxidize or stain in the presence of chlorides and sulfides, particularly in coastal areas and other harsh environments, such as the warm, highly humid atmosphere around pools and hot tubs. These stains could be perceived as rust, but can be easily removed or prevented. To provide stain prevention and removal, wash all stainless steel surfaces every 3-4 weeks or as often as required with fresh water and/or stainless steel cleaner.



WARNING! Turn off the gas at the source and disconnect the unit before servicing. To avoid the possibility of burns, maintenance should be done only when the grill is cool. A leak test must be performed annually and whenever any component of the gas train is replaced or gas smell is present.

Combustion Air Adjustment: (This must be done by a qualified gas installer.) The air shutter is factory set and should not need adjusting under normal conditions. Under extreme field conditions, adjustments might be required. When the air shutter is adjusted correctly the flames will be dark blue, tipped with light blue and occasionally yellow.

- With too little air flow to the burner, the flames are lazy yellow and can produce soot.
- With too much air flow, the flames lift erratically and can cause difficulties when lighting.

Adjusting the air shutter:

1. Remove cooking grids and sear plates and leave lid open.
2. Loosen air-shutter lock screw located at the mouth of the burner and open or close air shutter as required. The normal opening settings are:

Main Tube Burner	Propane 5/32" (4mm)
	Natural 5/32" (4mm)

*Infra-Red burners have no air adjustment.

3. Light the burners and set to high. Visually inspect burner flames. When the shutters are set correctly, turn burners off, tighten locking screws, and replace removed parts. Ensure that the insect screens are installed.

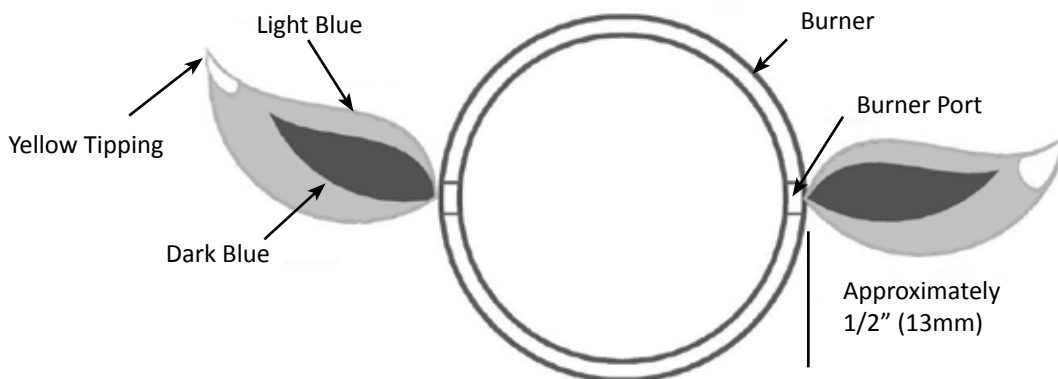

Grids And Warming Rack: The grids and warming rack are best cleaned with a brass wire brush during the pre-heating period. Steel wool can be used for stubborn stains. It is normal that stainless grids (if equipped) will discolor permanently from regular usage due to the high temperature of the cooking surface.

Cast Iron Cooking Grids: The cast iron cooking grids supplied with your new grill offer superior heat retention and distribution. By regularly seasoning your grids you are adding a protective coating, which will aid in resisting corrosion and increase your grids non-stick capabilities.

First Time Use: Wash the cooking grids by hand with mild dish soap and water to remove any residue from the manufacturing process (never wash in a dish washer). Rinse thoroughly with hot water and dry completely with a soft cloth. This is important to avoid moisture from entering the cast iron.

Seasoning: Using a soft cloth, spread VEGETABLE SHORTENING over the entire grid surface ensuring all grooves and corners are covered. Do not use salted fats such as butter or margarine. Pre-heat your grill for 15 minutes, then place the seasoned cooking grids in the grill. Turn the burner control knobs to medium with the lid closed. Allow the cooking grids to heat for approximately one-half hour. Turn all the burners to the "OFF" position and turn the gas off at the source. Let the cooking grids stand until cool. This procedure should be repeated several times throughout the season, although it is not required for daily use (follow daily usage procedure below).

Daily Usage: Before pre-heating, and cleaning with a brass wire grill brush, coat the entire top surface of the cooking grids with VEGETABLE SHORTENING. Pre-heat the grill and then brush away any unwanted residue with a brass wire brush.

Stainless Steel Cooking Grids: (upgrade kit available - see replacement parts list). Stainless steel cooking grids are durable and corrosion resistant. They require less seasoning and maintenance than cast iron cooking grids. It is recommended that you follow the daily usage procedure listed above although you may find pre-heating and cleaning your grids with a wire brush is sufficient for your grilling needs.

Control Panel: The control panel text is printed directly on the stainless steel and with proper maintenance will remain dark and legible. To clean the panel, use only warm soapy water or stainless steel cleaner available from your Napoleon dealer. Never apply abrasive cleaners on any stainless surfaces, especially the printed portion of the control panel or the printing will gradually rub off.

Cleaning Inside The Gas Grill: Remove the cooking grids. Use a brass wire brush to clean loose debris from the casting sides and underneath the lid. Scrape the sear plates with a putty knife or scraper, and use a wire brush to remove the ash. Remove the sear plates and brush debris from the burners with the brass wire brush. Sweep all debris from inside the gas grill into the drip pan.

Drip Pan: Accumulated grease is a fire hazard. Clean the drip pan frequently (every 4 – 5 uses or as often as required) to avoid grease buildup. Grease and excess drippings pass through to the drip pan, located beneath the gas grill and accumulate in the disposable grease tray below the drip pan. To access the disposable grease tray or to clean the drip pan, slide the drip pan free of the grill. Never line the drip pan with aluminum foil, sand or any other material as this could prevent the grease from flowing properly. The pan should be scraped out with a putty knife or scraper. Replace the disposable grease tray every 2 – 4 weeks, depending on gas grill usage. For supplies, see your Napoleon Gas Grill dealer.

Cleaning The Outer Grill Surface: Do not use abrasive cleaners or steel wool on any painted, porcelain or stainless steel parts of your Napoleon Grill. Doing so will scratch the finish. Exterior grill surfaces should be cleaned with warm soapy water while the metal is still warm to the touch. To clean stainless surfaces, use a stainless steel or a non-abrasive cleaner. Always wipe in the direction of the grain. Over time, stainless steel parts discolor when heated, usually to a golden or brown hue. This discoloration is normal and does not affect the performance of the grill. Porcelain enamel components must be handled with additional care. The baked-on enamel finish is glass-like, and will chip if struck. Touch-up enamel is available from your Napoleon Grill dealer.



WARNING! Hose: Check for abrasions, melting, cuts, and cracks in the hose. If any of these conditions exist, do not use the gas grill. Have the part replaced by your Napoleon Gas Grill dealer or qualified gas installer.



Tube Burner: The burners are made from heavy wall 304 stainless steel, but extreme heat and a corrosive environment can cause surface corrosion to occur. This can be removed with a brass wire brush.

CAUTION! Beware of Spiders.

Spiders and insects are attracted to the smell of propane and natural gas. The burner is equipped with an insect screen on the air shutter, which reduces the likelihood of insects building nests inside the burner but does not entirely eliminate the problem. A nest or web can cause the burner to burn with a soft yellow or orange flame or cause a fire (flashback) at the air shutter beneath the control panel. **To clean the inside of the burner, it must be removed from the gas grill:** Remove the screw that attaches the burner to the back wall. Slide the burner back and upwards to remove. **Cleaning:** Use a flexible venturi tube brush to clean the inside of the burner. Shake any loose debris from the burner through the gas inlet. Check the burner ports and valve orifices for blockages. Burner ports can close over time due to cooking debris and corrosion, use an opened paperclip or the supplied port maintenance bit to clean them. Drill out blocked ports using this drill bit in a small cordless drill. The ports are easier to clean if the burner is removed from the grill, but it can also be done with the burner installed. Do not flex the drill bit when drilling the ports, as this will cause the drill bit to break. This drill is for burner ports only, not for the brass orifices (jets) which regulate the flow into the burner. Take care not to enlarge the holes. Ensure the insect screen is clean, tight, and free of any lint or other debris.

Reinstallation: Reverse the procedure to reinstall the burner. Check that the valve enters the burner when installing.



WARNING! When reinstalling the burner after cleaning it is very important that the valve/orifice enters the burner tube before lighting your gas grill. If the valve is not inside the burner tube a fire or explosion could occur.

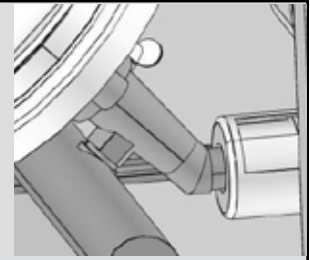

Troubleshooting

Problem	Possible Causes	Solution
Low heat / Low flame when valve turned to high.	For propane - improper lighting procedure. For natural gas - undersized supply line. For both gases - improper preheating.	Ensure lighting procedure is followed carefully. All gas grill valves must be in the off position when the tank valve is turned on. Turn tank on slowly to allow pressure to equalize. See lighting instructions. Pipe must be sized according to installation code. Preheat grill with both main burners on high for 10 to 15 minutes.
Excessive flare-ups/ uneven heat.	Sear plates installed incorrectly. Improper preheating. Excessive grease and ash build on sear plates and in drip pan.	Ensure sear plates are installed with the holes towards the front and the slots on the bottom. See assembly instructions. Preheat grill with both main burners on high for 10 to 15 minutes. Clean sear plates and drip pan regularly. Do not line pan with aluminum foil. Refer to cleaning instructions.
Burners burn with yellow flame, accompanied by the smell of gas.	Possible spider web or other debris, or improper air shutter adjustment.	Thoroughly clean burner by removing. See general maintenance instructions. Open air shutter slightly according to combustion air adjustment instructions. (This must be done by a qualified gas installer.)

Problem	Possible Causes	Solution
Flames lift away from burner, accompanied by the smell of gas, and possibly difficulties in lighting.	Improper air shutter adjustment.	Close air shutter slightly according to combustion air adjustment instructions. (This must be done by a qualified gas installer.)
Humming regulator.	Normal occurrence on hot days.	This is not a defect. It is caused by internal vibrations in the regulator and does not affect the performance or safety of the gas grill. Humming regulators will not be replaced.
Burners will not cross light each other.	Plugged ports at back of burner.	Clean burner ports. See burner maintenance instructions.
"Paint" appears to be peeling inside lid or hood.	Grease build-up on inside surfaces.	This is not a defect. The finish on the lid and hood is porcelain, and will not peel. The peeling is caused by hardened grease, which dries into paint-like shards, that flake off. Regular cleaning will prevent this. See cleaning instructions.
Infrared burner (if equipped) flashes back (during operation the burner abruptly makes a loud "whoosh" sound, followed by a continuous blow-torch type sound and grows dim.)	<p>Ceramic tiles overloaded with grease drippings and build-up. Ports are clogged.</p> <p>Burner overheated due to inadequate ventilation (too much grill surface covered by griddle or pan.)</p> <p>Cracked ceramic tile.</p> <p>Leaking gasket surrounding the ceramic tile, or a weld failure in the burner housing.</p>	<p>Turn burner off and allow to cool for at least two minutes. Relight burner and burn on high for at least five minutes or until the ceramic tiles are evenly glowing red.</p> <p>Ensure that no more than 75% of the grill surface is covered by objects or accessories. Turn burner off and allow to cool for at least two minutes, then relight.</p> <p>Allow burner to cool and inspect very closely for cracks. If any cracks are found, contact your authorized Napoleon dealer to order a replacement burner assembly.</p> <p>Contact your authorized Napoleon dealer for instructions on ordering a replacement burner assembly.</p>

KEEP YOUR RECEIPT AS PROOF OF PURCHASE TO VALIDATE YOUR WARRANTY.

Ordering Replacement Parts

Warranty Information

MODEL: _____

DATE OF PURCHASE: _____

SERIAL NUMBER: _____

(Record information here for easy reference)

Before contacting the Customer Care Department, check the NAC Website for more extensive cleaning, maintenance, troubleshooting and parts replacement instructions at www.napoleongrills.com. Contact the factory directly for replacement parts and warranty claims. Our Customer Care Department is available between 9 AM and 5 PM (Eastern Standard Time) at 1-866-820-8686 or fax at 1-705-727-4282. To process a claim, we must be provided with the following information:

1. Model and serial number of the unit.
2. Part number and description.
3. A concise description of the problem ('broken' is not sufficient).
4. Proof of purchase (photocopy of the invoice).

In some cases the Customer Care Representative could request to have the parts returned to the factory for inspection before providing replacement parts. These parts must be shipped prepaid to the attention of the Customer Care Department with the following information enclosed:

1. Model and serial number of the unit.
2. A concise description of the problem ('broken' is not sufficient).
3. Proof of purchase (photocopy of the invoice).
4. Return Authorization Number - provided by the Customer Care Representative.

Before contacting customer care, please note that the following items are not covered by the warranty:

- Costs for transportation, brokerage or export duties.
- Labor costs for removal and reinstallation.
- Costs for service calls to diagnose problems.
- Discoloration of stainless steel parts.
- Part failure due to lack of cleaning and maintenance, or use of improper cleaners (oven cleaner).



CAUTION! During unpacking and assembly we recommended you wear work gloves and safety glasses for your protection. Although we make every effort to make the assembly process as problem free and safe as possible, it is characteristic of fabricated steel parts that the edges and corners might be sharp and could cause cuts if handled incorrectly.

Getting Started

1. Remove all cart panels, hardware, and grill head from carton. Raise lid and remove any components packed inside. Use the parts list to ensure all necessary parts are included.
2. Do not destroy packaging until the grill has been fully assembled and operates to your satisfaction.
3. Assemble the grill where it is to be used, lay down cardboard or a towel to protect parts from being lost or damaged while assembling.
4. Most stainless steel parts are supplied with a protective plastic coating that must be removed prior to using grill.
5. Follow all instructions in the order that they are laid out in this manual.
6. Two people are required to lift the grill head onto the assembled cart.

If you have any questions about assembly or grill operation, or if there are damaged or missing parts please call our Customer Care Department at 1-866-820-8686 between 9 AM and 5 PM (Eastern Standard Time).

TOOLS REQUIRED FOR ASSEMBLY (tools not included)

3/8 (10mm)
Wrench,
ratchet or driver



Flat and Philips
screwdrivers



Pliers



Hammer





1 X N430-0002

1. Magnet Installation

Snap magnet into slot in front of bottom shelf.

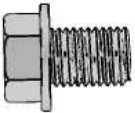
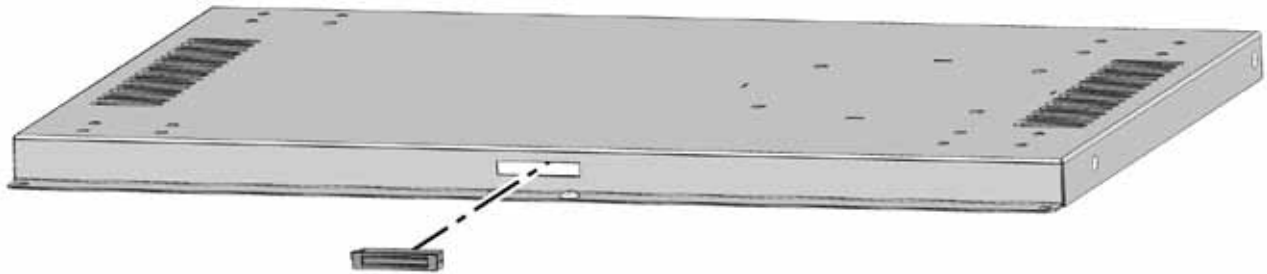

16 X N570-0073 (1/4-20 X 3/8")



16 X N450-0027 (1/4-20)



3/8"(10mm) 7/16"(11mm)

2. Caster/Bracket Installation

Attach (4) casters, using (4) 1/4 -20 x 3/8" screws and (4) 1/4 -20 lock nuts for each caster. Attach brackets under front casters as illustrated. Tighten securely.

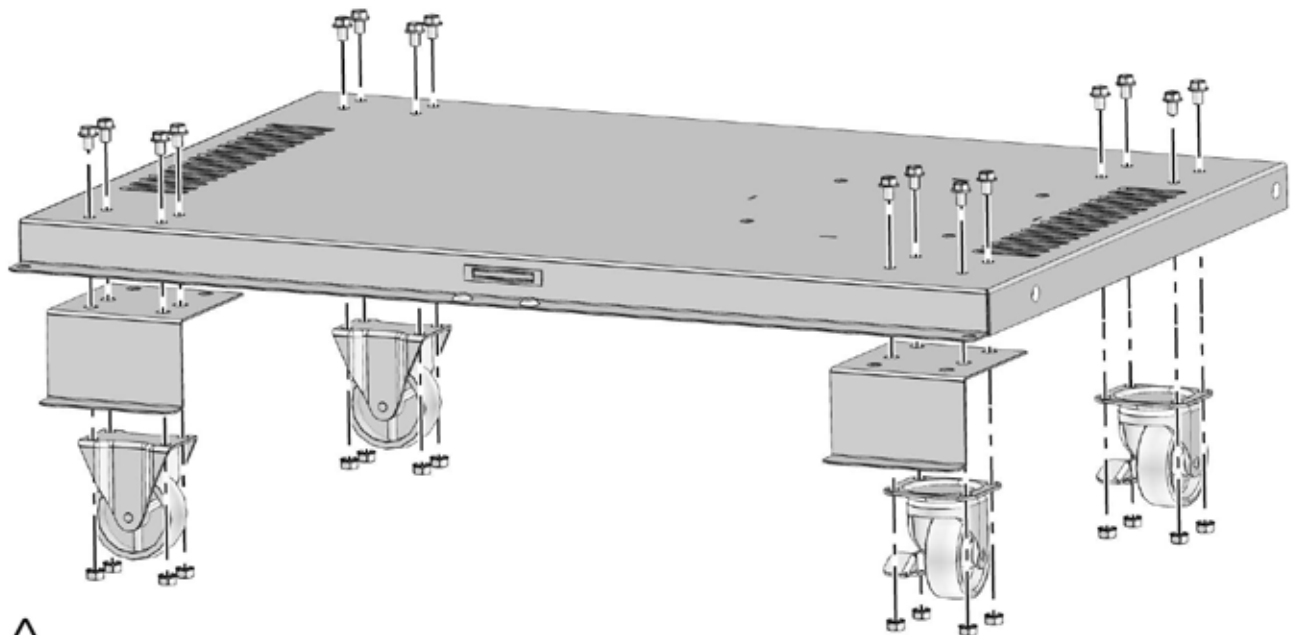

non revolving caster- left side



Propane Only

3. Propane Tank Ring Installation

Insert propane tank ring into slots in bottom of shelf as shown. Fold tabs over to secure in place.

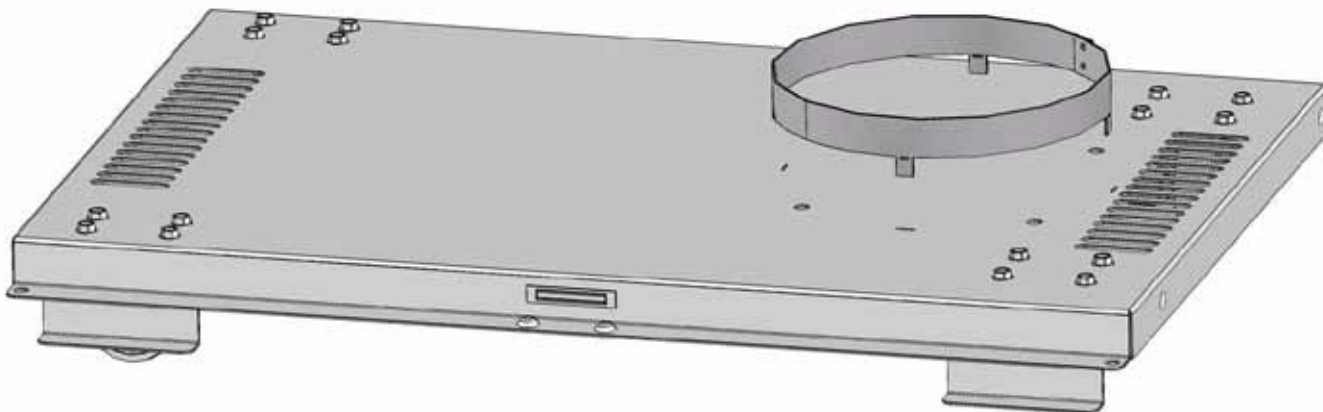

4 x N570-0080 (#14 x 1/2")



3/8"(10mm)

4. Left and Right Cart Panel Installation

Install end cart panels ensuring slots in panel are to the top, rest panel on bottom shelf and line up holes. Fasten using (4) #14 x 1/2" screws.

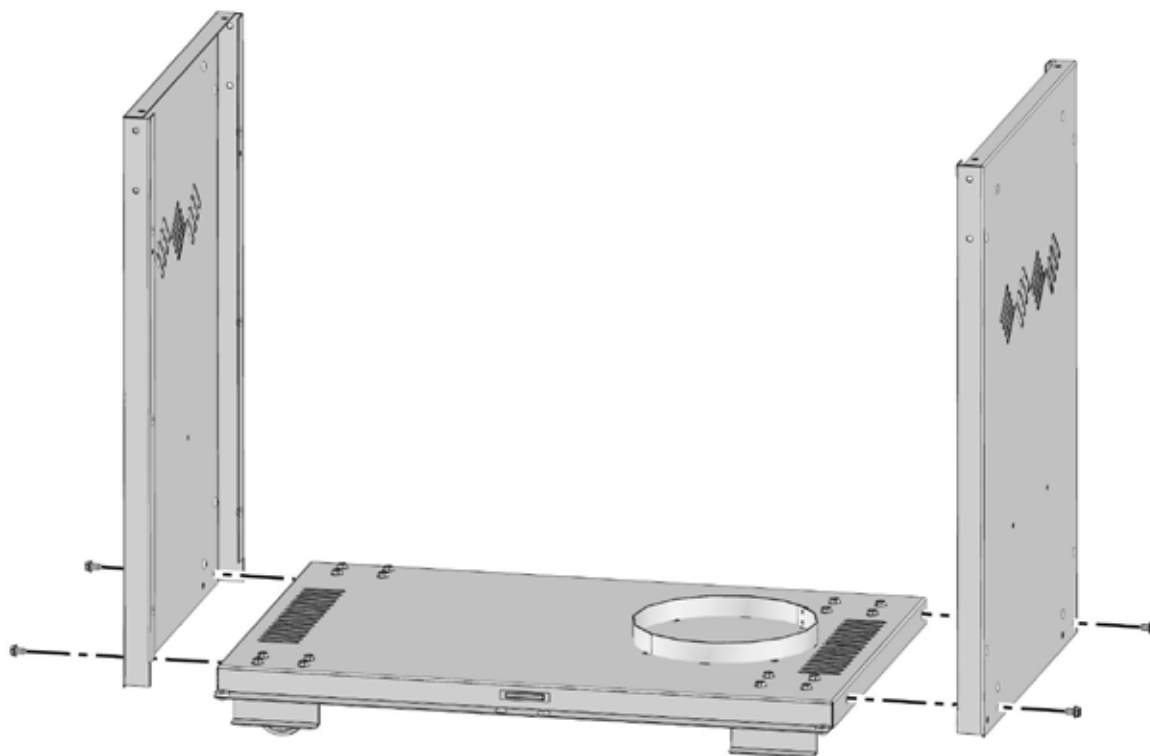



6 x N570-0080 (#14 x 1/2")



3/8"(10mm)

5. Rear Cart Panel Installation

Fit rear cart panel between the two end panels; ensure large hole in panel is to the bottom right corner as illustrated. Fasten using (6) #14 x 1/2" screws, three on each side.

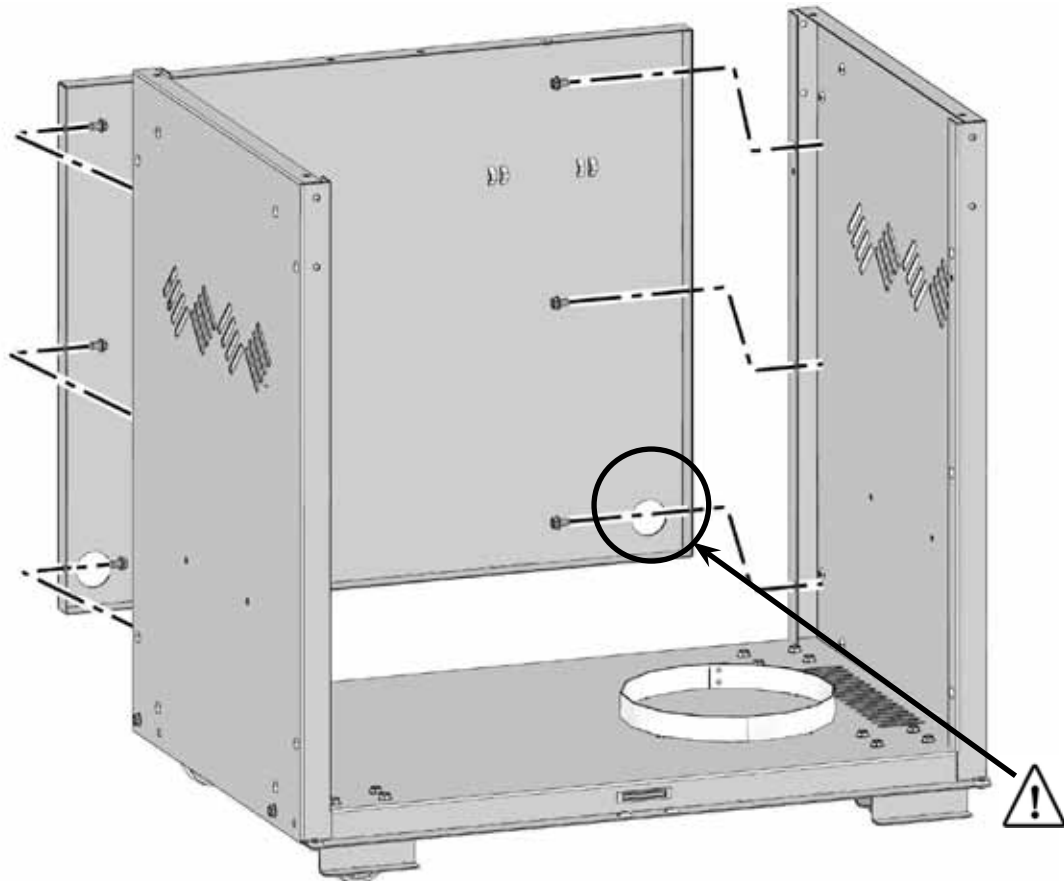



1 x N570-0080 (#14 x 1/2")



3/8" (10mm)

6. Tank Inhibitor Bracket / Propane Tank Mount Installation

Insert tank inhibitor bracket into slot in rear panel as illustrated. Fasten to bottom panel using (1) #14 x 1/2" screw. Clip top propane tank mount into slots in back panel. Insert one end at a time, gently bending wire. (When not in use tank mount will lay flat against back panel).



Propane Only

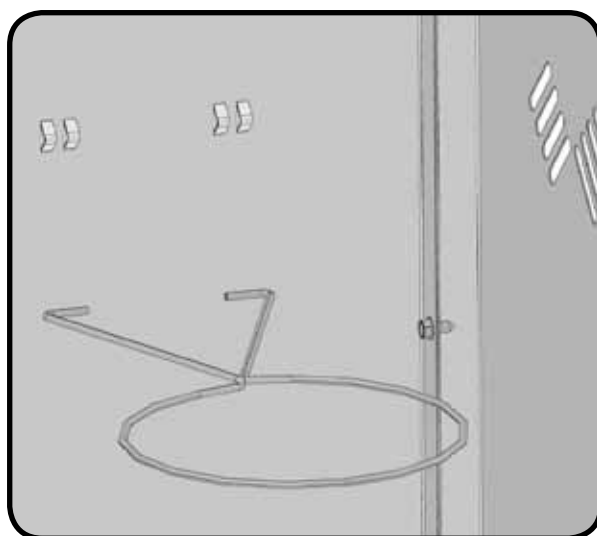
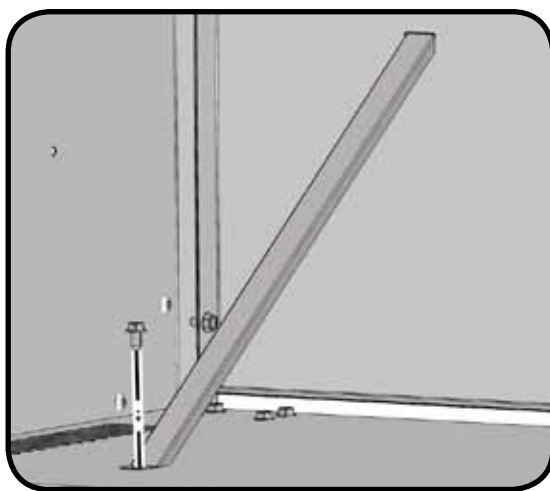
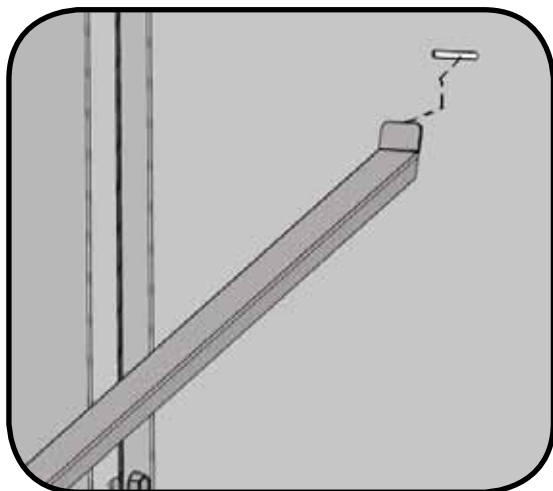



4 x N570-0080 (#14 x 1/2") 1 X N430-0002

3/8"(10mm)

7. Front Cabinet Support Installation

Fasten top rail assembly to the front of side panels using (4) #14 x 1/2" screws. For ease of installation start all screws before tightening completely. Snap magnet into place as shown.

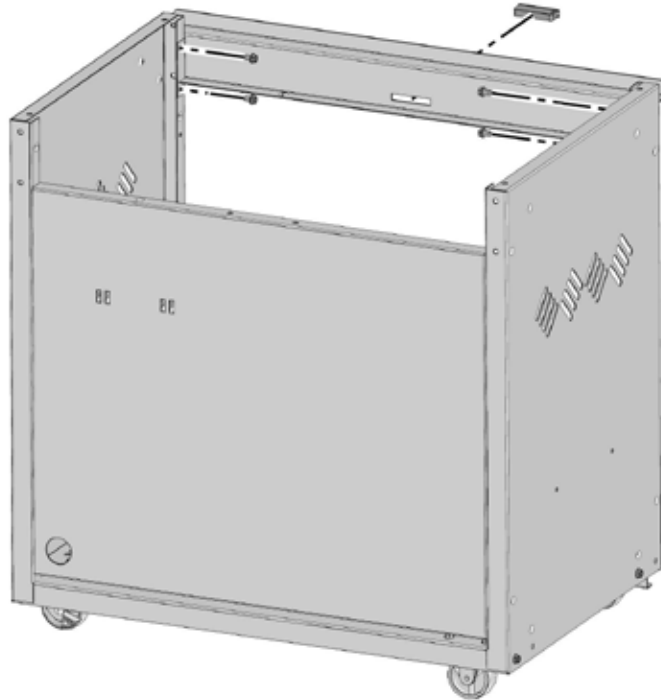

4 x N570-0080 (#14 x 1/2")

3/8"(10mm)

8. Heat Shield Installation

Attach heat shield using (4) #14 x 1/2" screws. Attach one end under lip of back panel and other end to underside of front cabinet support.

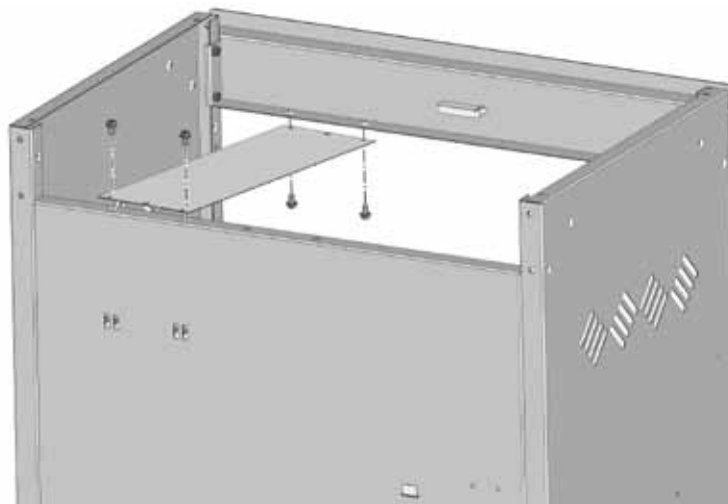

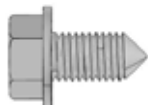

4 x N570-0091 (1/4-20 X 1/2")



3/8" (10mm)

9. Grill Head Installation

PROPANE ONLY – To avoid assembly difficulties, prior to mounting the grill head, remove zip tie holding regulator up under control panel. This was installed at the factory to protect the regulator hose during shipping and is no longer required. (Take care when removing the tie not to damage the hose). Ensure the regulator drops into the small opening, between the tank heat shield and the right side of the cabinet.

Lift grill head and place on assembled cart, lining up holes in top of side cart panels with holes in bottom of base. Fasten from inside using (4) 1/4-20 x 1/2" screws, two per side.

Two people are required for this step.



Correct Assembly

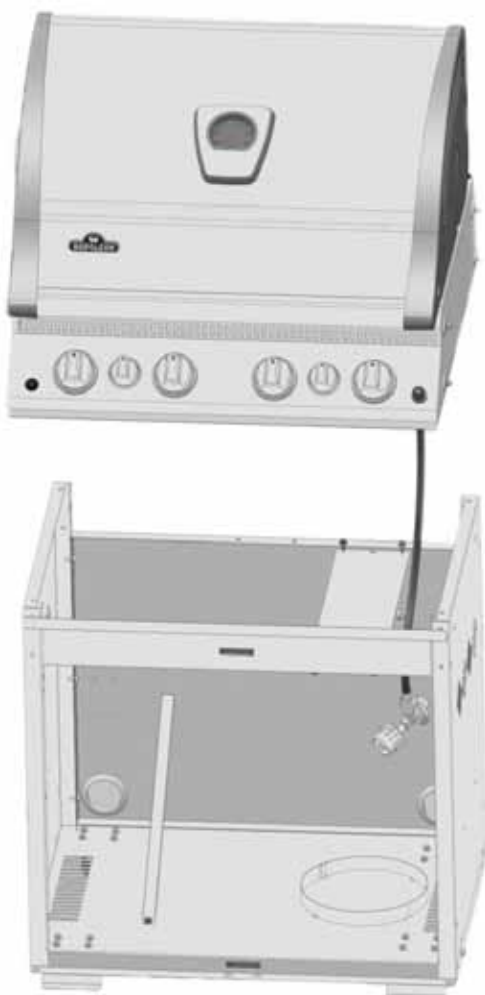

Incorrect Assembly

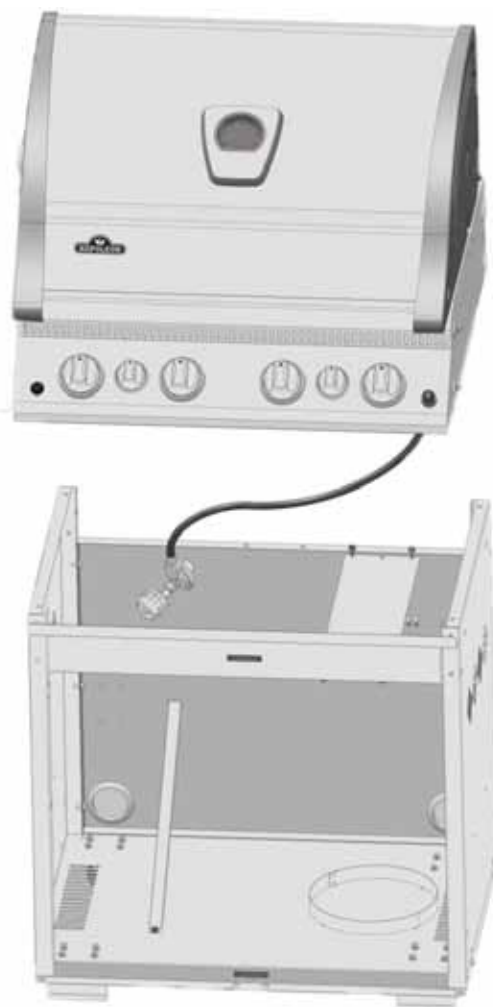

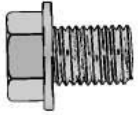

2 x N570-0073 (1/4-20 X 3/8")



3/8"(10mm)

10. Battery Pack / Rotisserie Mount Installation

Install battery pack below vent slots on left hand panel using magnet supplied with battery pack. Plug wire from LED (lights) located underneath control panel into wire from battery pack. Install rotisserie mount bracket to left side of barbecue as shown using (2) 1/4 – 20 x 3/8" screws.

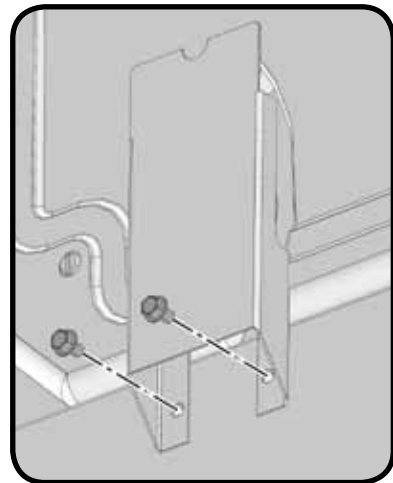
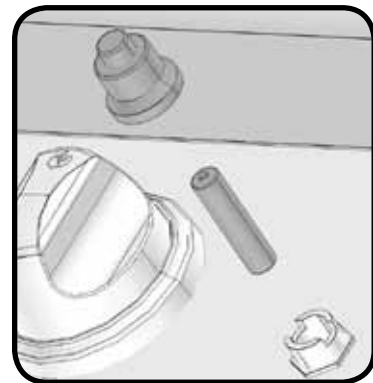
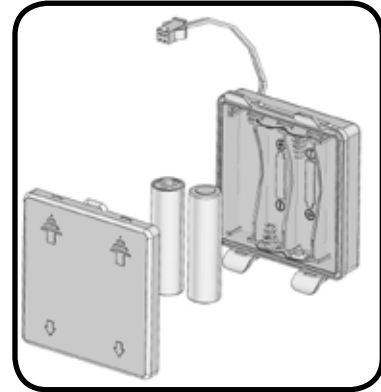
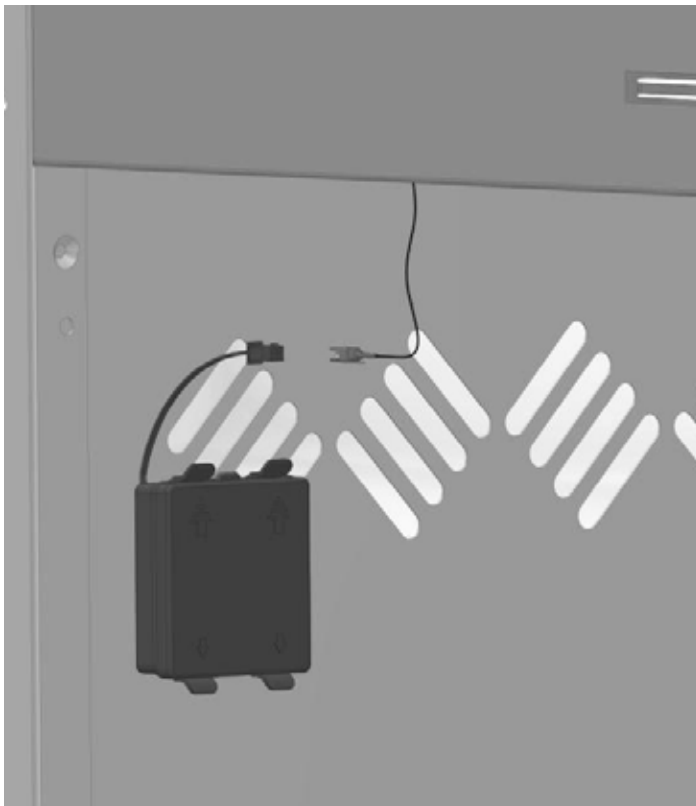



8 x N570-0076 (#8 X 1/2")



4 x N570-0013 (#8 X 5/8")



11. Side Shelf Assembly

Peel the protective coating from the side shelf. Insert the top of the side shelf into the end cap engaging the edge of the shelf under the ribs in the end cap as illustrated. Push the bottom tabs into the end cap and line up holes. Attach the end cap to the side shelf using (4) #8 x 1/2" screws per shelf. On the underside of the side shelf fasten the end cap using (2) #8 x 5/8" screws one on either end.

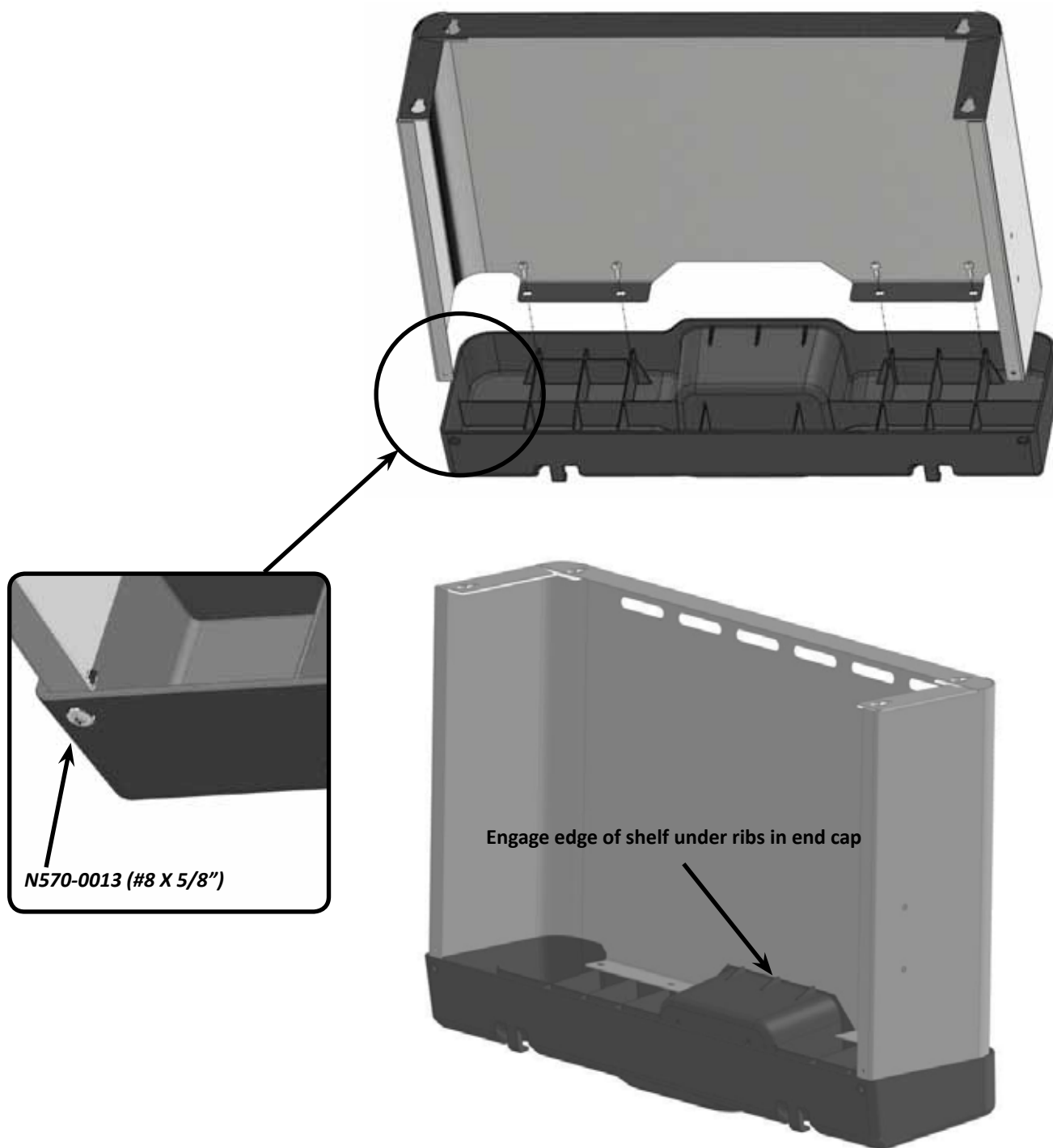

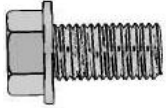

4 x N570-0082 (1/4-20 X 5/8")

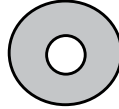

4 x N735-0001 (insulated washer)



3/8"(10mm)

12. Side Shelf Installation

Insert (4) 1/4 - 20 x 5/8" screws through the washers into the threaded holes in the side of the base; do not tighten all the way. Slide the assembled side shelf over the screw heads and finish tightening.

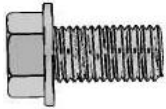
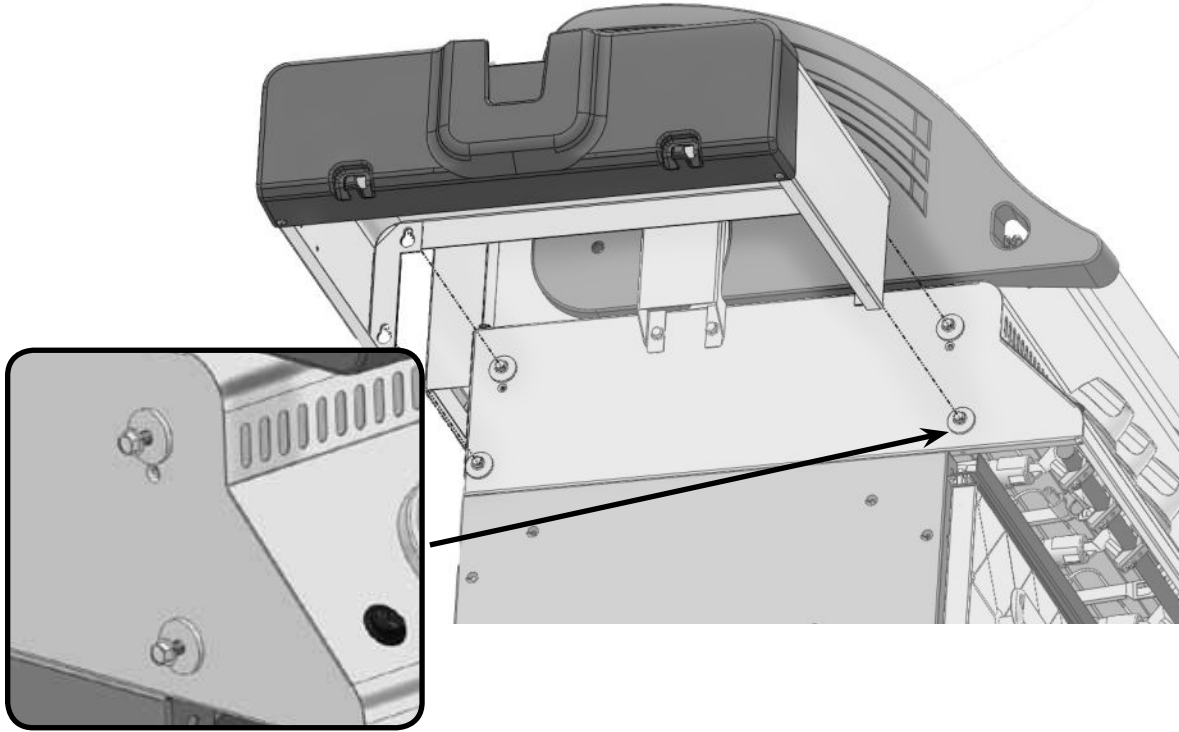

4 x N570-0082 (1/4-20 X 5/8")

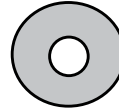

4 x N735-0001 (insulated washer)



1 x N160-0016 (clip)



3/8"(10mm)

13. Side Burner Installation

Insert (4) 1/4-20 x 5/8" screws through the washers into the threaded holes in the side of the base; do not tighten all the way. Slide the assembled side burner over the screw heads and finish tightening.

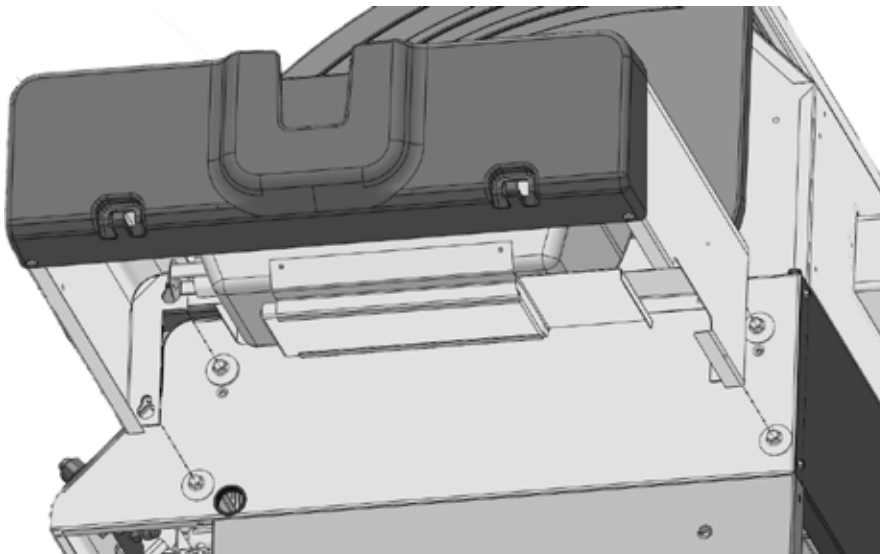

WARNING! The Infrared side burner is supplied with a drip pan which holds only a minimal amount of grease. To prevent grease fires, the pan must be cleaned after each use.

Fit the orifice into the burner tube and secure with the hose retainer clip supplied. Attach the wire from the manifold to the side burner electrode.

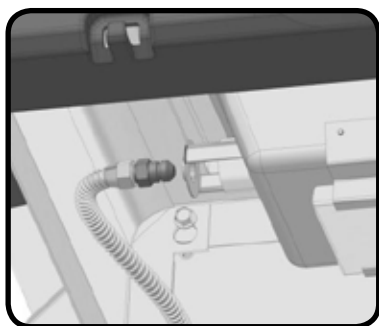

Fit orifice into burner tube and secure with hose retainer clip supplied.

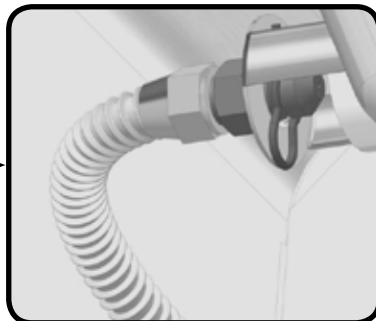
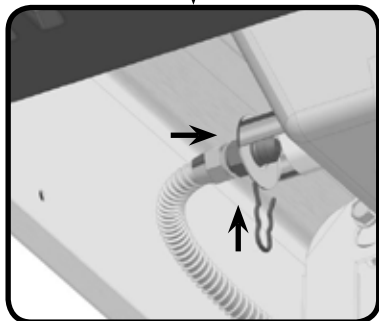
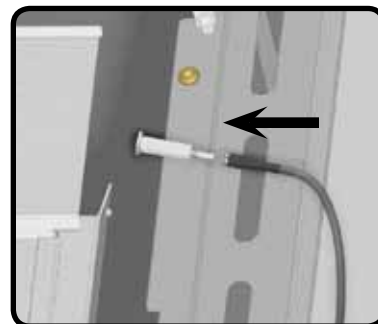

Cooking Grid Placement: The cooking grid can be placed at two different heights. The lower height is for use with pots or pans. The higher position is to be used when searing meats. Ensure the burner is off and the grid is cool to the touch before changing between the two heights. The grid must be at the lower height in order to close the lid.

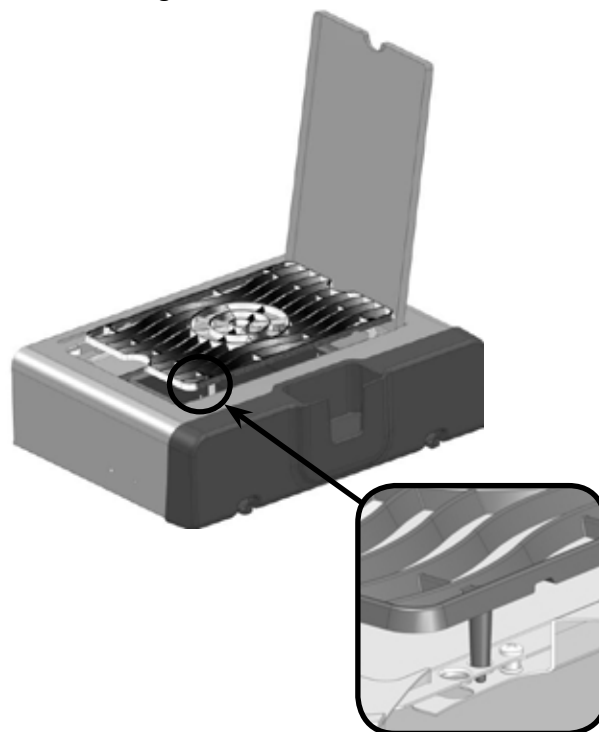
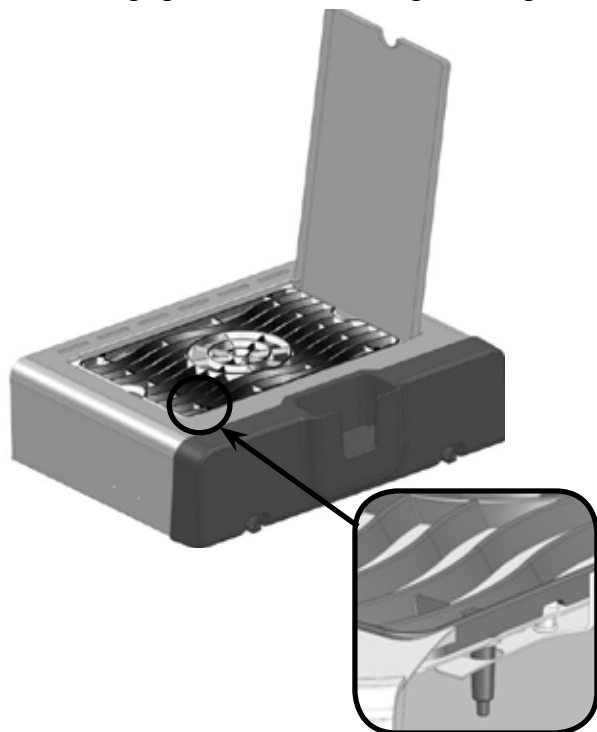

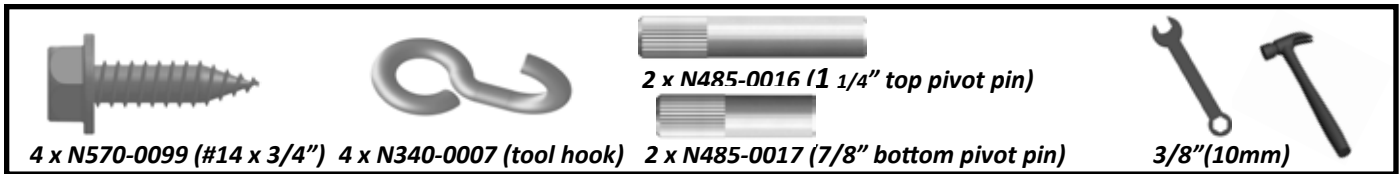

14. Door Assembly

Install the door handle onto the front of the door and the tool hooks onto the back of the door using (2) #14 x 3/4" screws per door. Press the door pivot pins into the holes in the top and bottom of each door as illustrated gently tapping with a hammer.

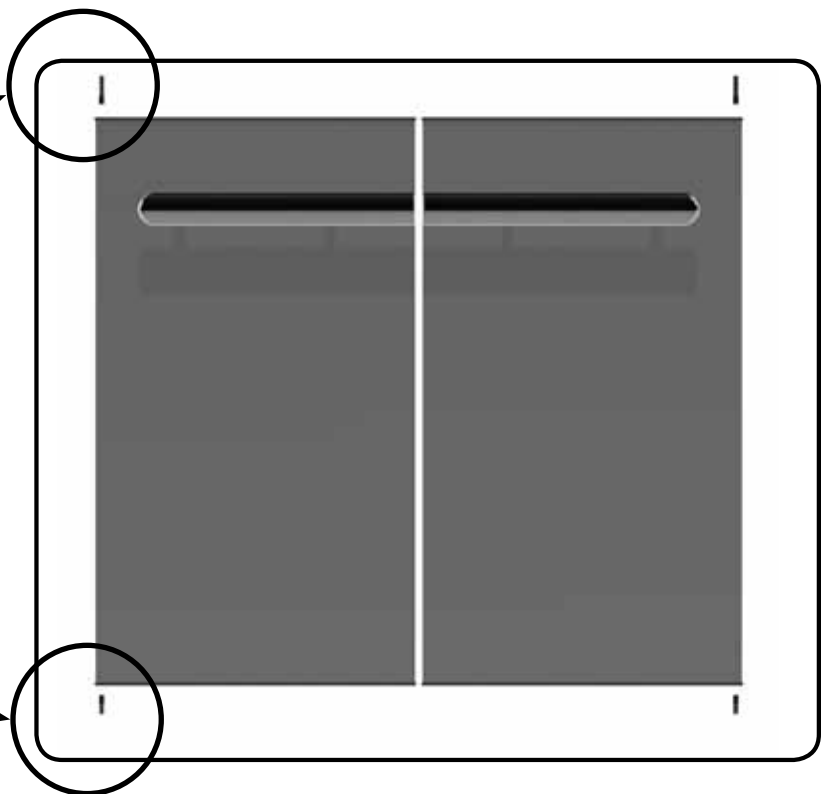
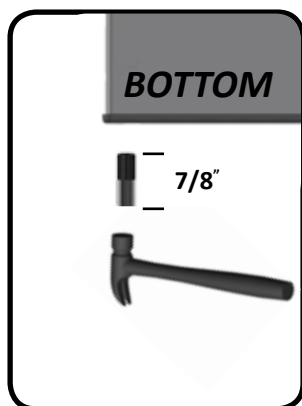
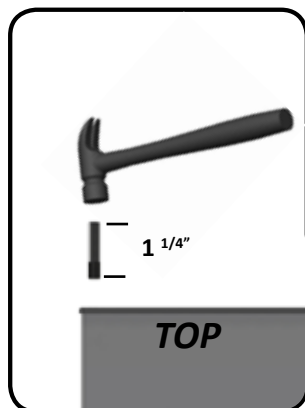
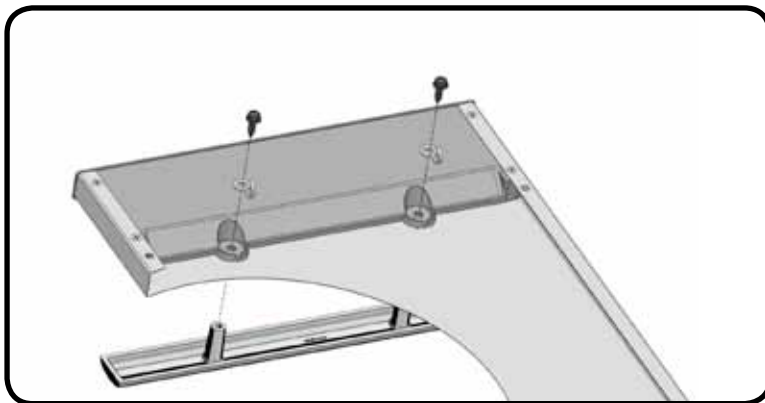

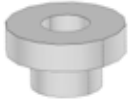

2 x N105-0011 (door bushing) 2 x N160-0022 (pivot pin clip)

15. Door Installation

First direct the pivot pin into the hole in the underside of the front cabinet support and then lower the door into the bushing in the bottom shelf. Once secure, snap the top pivot pin clip over the top pivot pin as illustrated.

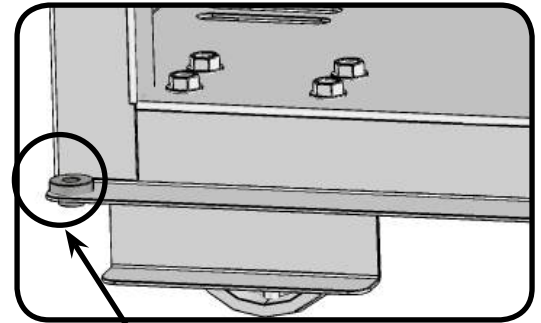
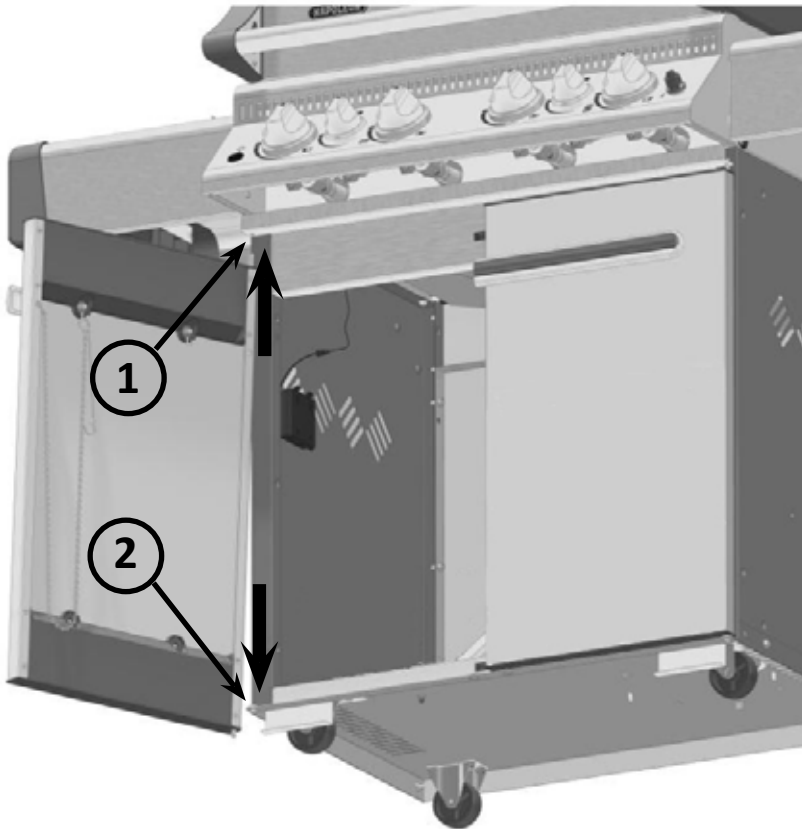

Bushing

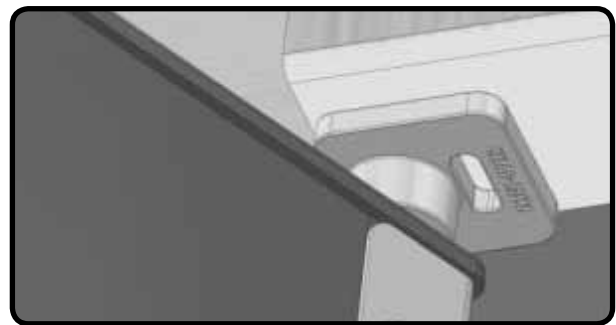
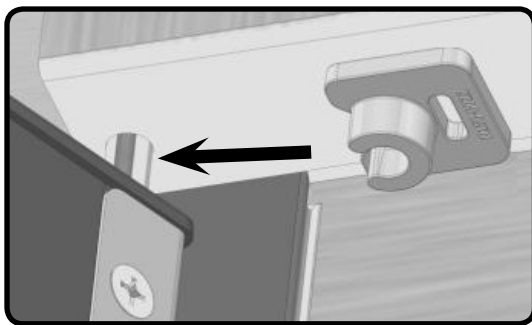

16. Condiment Basket Installation

Rotate basket slightly to allow wire to enter the holes in the side panel. Push through and upwards, rotating to allow the bend in the wire to pass through the holes. Lay basket flat against the side panel.

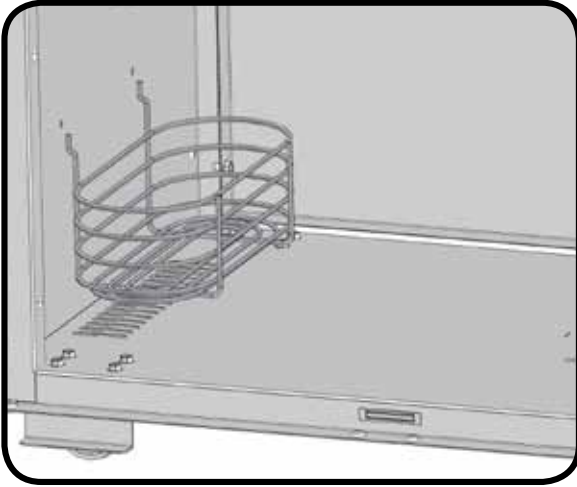

17. Sear Plate Installation

Insert sear plates into base, position one over each tube burner with slots down to allow drippings to travel through.

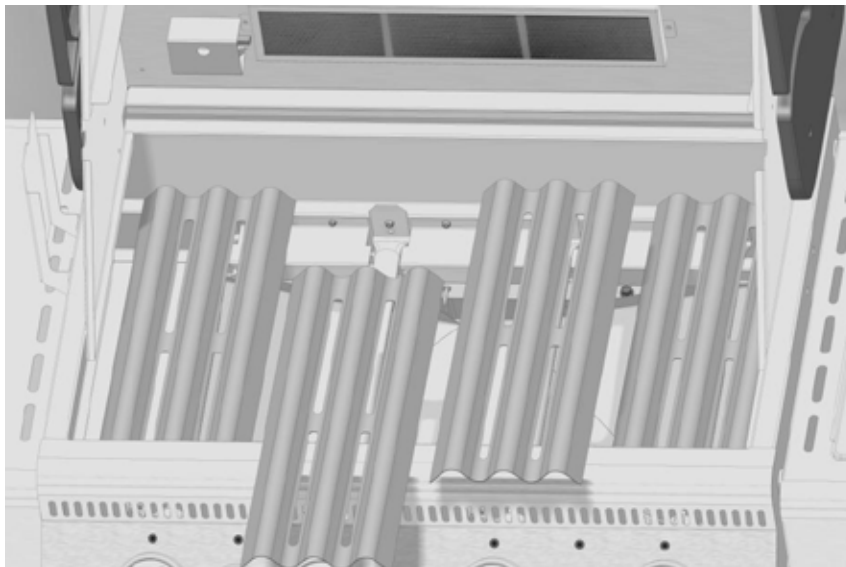

18. Grids and Warming Rack Installation

Position grids and warming rack into base as shown. Rest warming rack on brackets inside hood and grids on front and back lip of base.



19. Grease Tray and Holder Installation

Clip the wire grease tray holder into the two holes located in the center of the back panel. Place the aluminum grease tray into the grease tray holder.

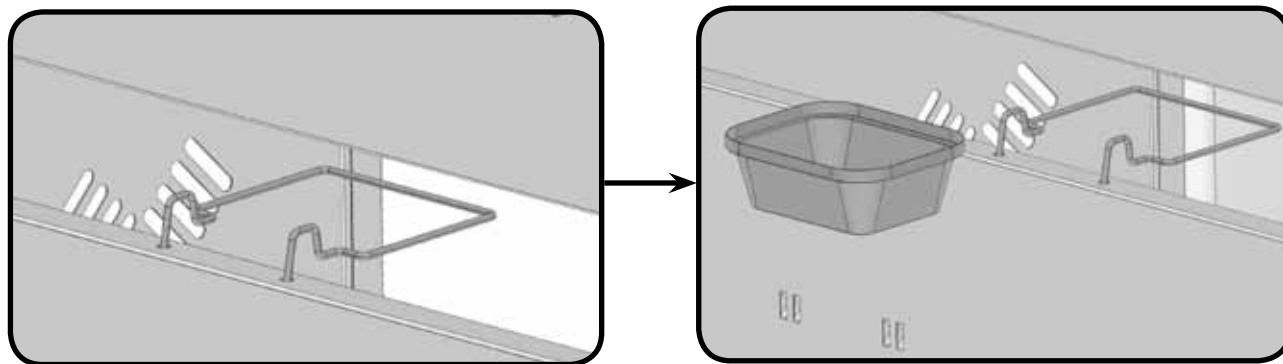

20. Drip Pan Installation

Slide drip pan into rear of base as shown. Ensure dip pan rides along rails on bottom of base.

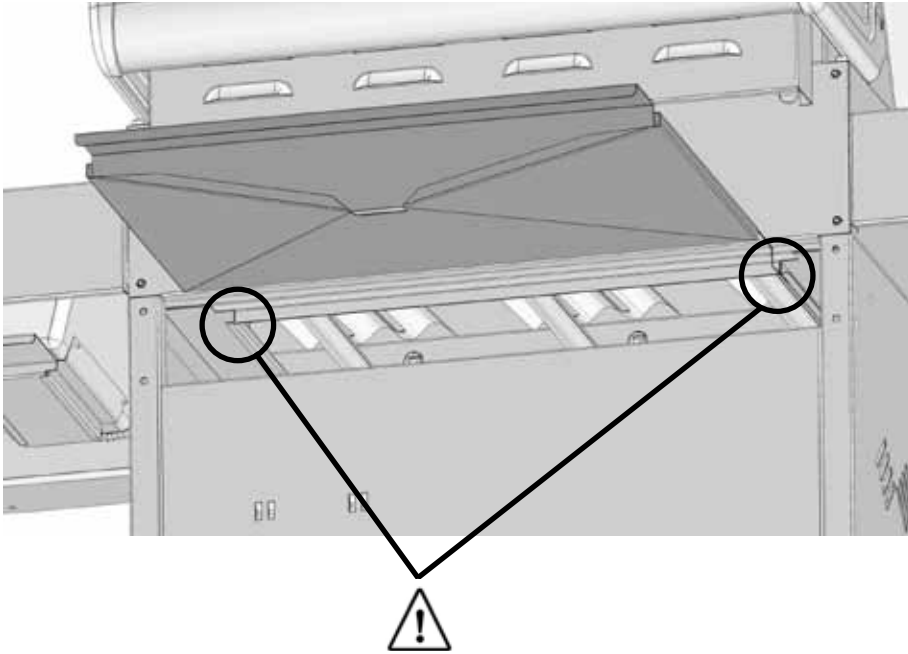

Rotisserie Kit Assembly Instruction

(optional)

Assemble rotisserie kit components as shown.

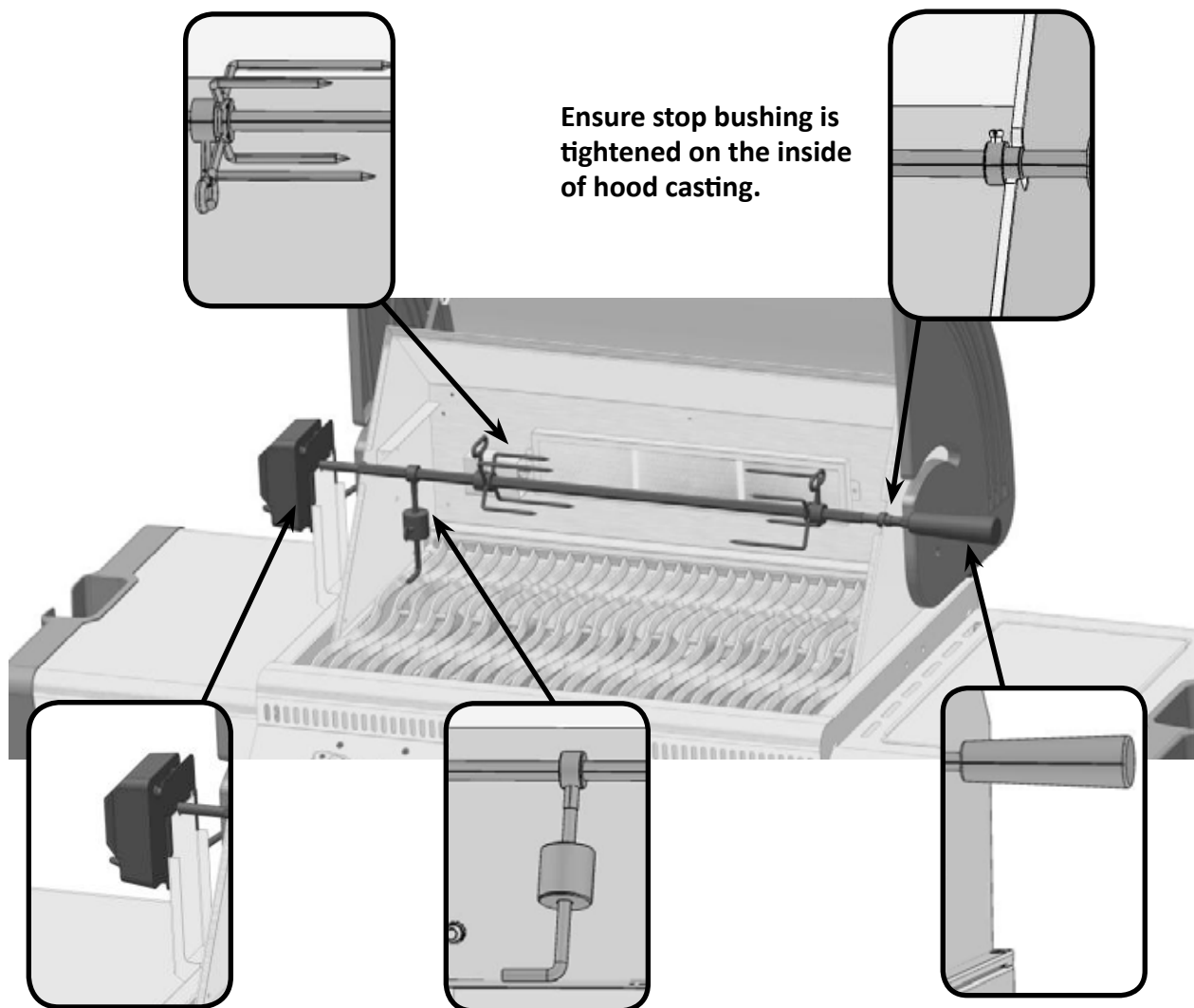

Propane Only – Proper Hose Connection



Ensure the regulator drops into the small opening, between the tank heat shield and the right side of the cabinet.

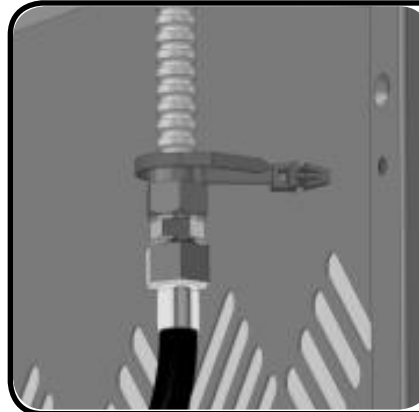
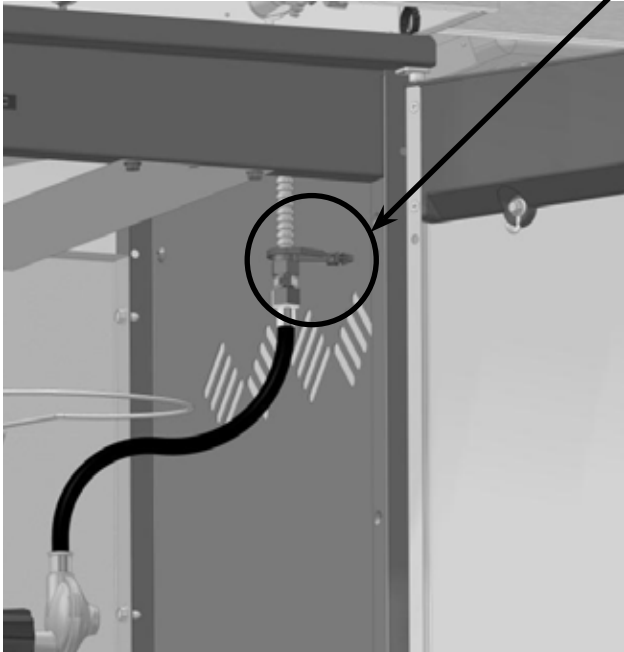

Clip hose to side panel using hose retainer clip supplied.

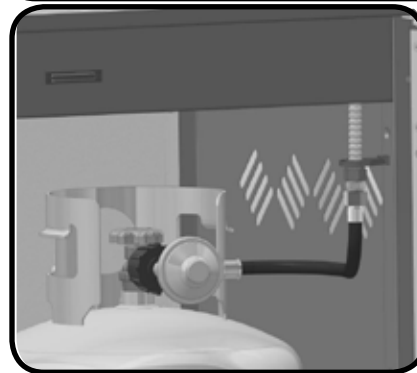

Propane Only – Improper Hose Connection



WARNING – FIRE HAZARD

The regulator must be attached so that no part of the hose touches the underside of the grill or drip pan. A fire will result if these directions are ignored.



Natural Gas Only – Proper Hose Connection



3/4" (19mm)



WARNING! The installation must be performed by a licensed gas fitter, and all connections must be leak tested before operating the grill. Do not use pipe dope or teflon tape on this connection. Tighten the connection with two wrenches.

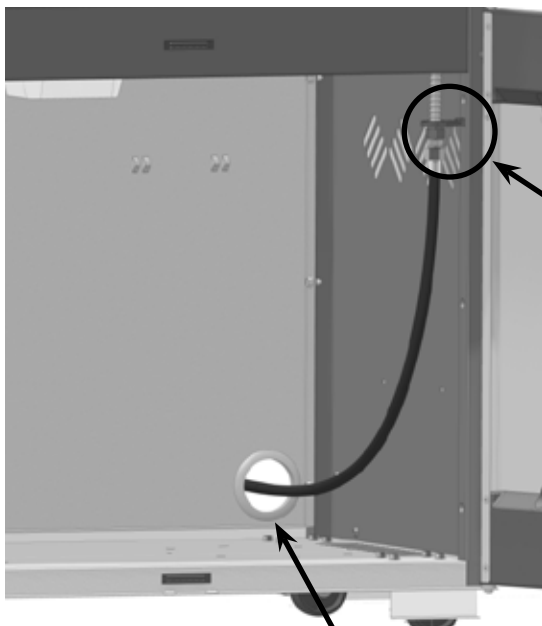

Bushing is pre-installed at factory.



Clip hose to side panel using hose retainer clip supplied.

Natural Gas Only – Improper Hose Connection



WARNING – FIRE HAZARD



WARNING! Do not route hose underneath drip pan.

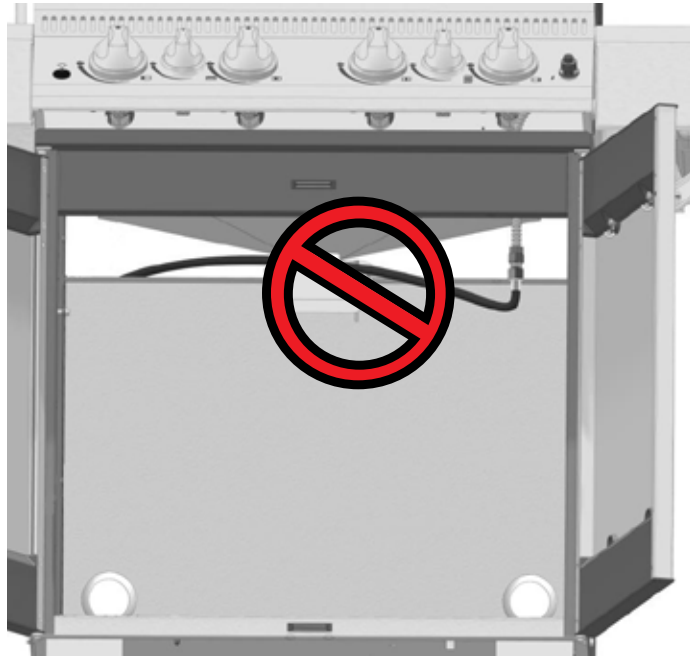

WARNING! Do not route hose over top of rear panel.



WARNING! Ensure the hose does not contact any high temperature surfaces, or it may melt and leak causing a fire.

Leak Testing Instructions



WARNING! A leak test must be performed annually and each time a cylinder is hooked up or if a part of the gas system is replaced.



WARNING! Never use an open flame to check for gas leaks. Be certain no sparks or open flames are in the area while you check for leaks. Sparks or open flames will result in a fire or explosion, damage to property, serious bodily injury, or death.



Leak testing: This must be done before initial use, annually, and whenever any gas components are replaced or serviced. Do not smoke while performing this test, and remove all sources of ignition. See Leak Testing Diagram for areas to check. Turn all burner controls to the off position. Turn gas supply valve on.



Brush a half-and-half solution of liquid soap and water onto all joints and connections of the regulator, hose, manifolds and valves.

Bubbles will indicate a gas leak. Either tighten the loose joint or have the part replaced with one recommended by the Napoleon Customer Care department and have the grill inspected by a certified gas installer.

If the leak cannot be stopped, immediately shut off the gas supply, disconnect it, and have the grill inspected by a certified gas installer or dealer. Do not use the grill until the leak has been corrected.

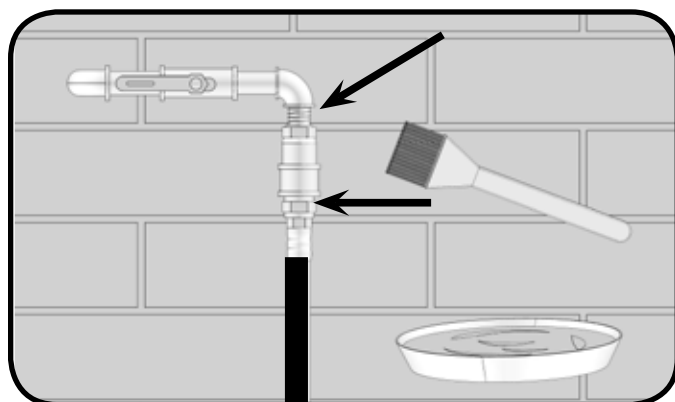
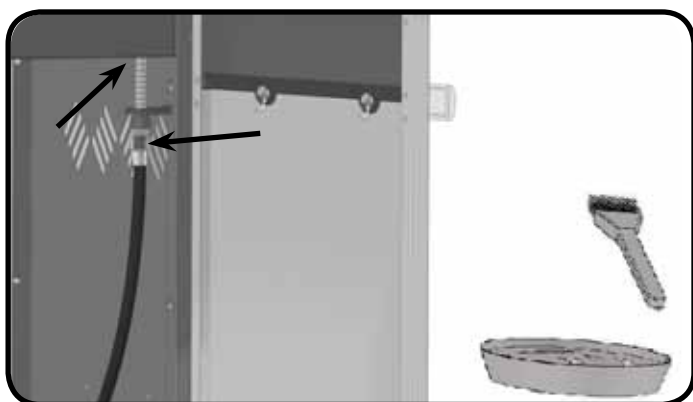
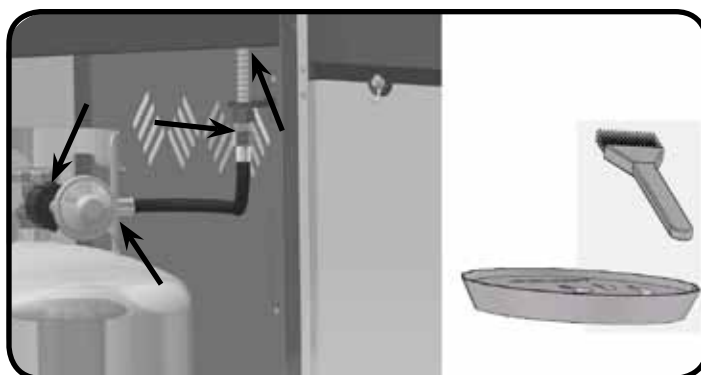

Parts List

Item	Part #	Description	RSIB
1	N135-0042-GY1HT	left side lid casting	x
2	N385-0129	NAPOLEON logo	x
3	W450-0005	logo spring clips	x
4	N510-0010	black silicone lid bumper	x
5	N685-0012	temperature gauge	x
6	N080-0287-GY1HT	lid casting cover	x
7	N335-0042L	stainless steel lid insert	x
8	N570-0024	1/4-20 x 1/2" screw	x
9	N010-0720	lid handle	x
10	N135-0043-GY1HT	right side lid casting	x
11	N570-0015	lid pivot screw	x
12	N010-0565	hood assembly	x
13	N570-0008	#8 x 1/2" screw	x
14	N570-0073	1/4-20 x 3/8" screw	x
15	N735-0003	1/4" lockwasher	x
16	N520-0023	warming rack	x
17	N305-0063	cooking grids - cast iron	x
	N370-0597	cooking grids - wave stainless rod	ac
18	N305-0057-M05	sear plate	x
19	N010-0722	stainless steel side burner shelf - right	x
20	N570-0076	#8 x 1/2" screw	x
21	N570-0082	1/4-20 x 5/8" screw	x
22	N010-0721-M06	stainless steel side shelf - left	x
23	N120-0020-GY0TX	LUXIDIO side shelf end cap	x
24	N200-0090-M06	infra red rear burner cover	x
25	N010-0526P	infra red rear burner	p
	N010-0526N	infra red rear burner	n
	N455-0054	rear burner orifice #59	p
	N455-0053	rear burner orifice #53	n
	N720-0053	rear burner supply tube	x
	N160-0017	clip rear burner tube	x
26	N240-0024P	rear burner electrode c/w pilot	p
	N240-0024N	rear burner electrode c/w pilot	n
27	N080-0206	rear burner electrode cover	x
28	N570-0079	rear burner electrode cover screw	x
	N615-0011	rear burner electrode cover spacer	x
29	N100-0036	main burner	x
30	N080-0281	main burner cross light bracket	x
31	N475-0199-M06	rotisserie mount	x
32	N010-0724	base	x
33	N010-0501-M08	drip pan	x
34	N160-0014	grease tray holder	x
35	N185-0001	replacement grease tray aluminium	x
36	N200-0089P	back cover	x
37	N475-0291CT	control panel	x
38	N380-0011	control knob	x

Parts List

Item	Part #	Description	RSIB
39	N051-0006	control knob bezel	x
40	N530-0003	1-outlet regulator	p
	N345-0001	10ft n/g hose c/w quick disconnect	n
41	N010-0716	manifold assembly c/w valves	p
	N010-0717	manifold assembly c/w valves	n
42	N720-0044	manifold flex connector	x
43	N255-0027	union fitting 3/8" - 3/8"	x
44	N340-0007	tool hook	x
45	N380-0019	control knob	x
	N720-0053	rear burner supply tube	x
46	N051-0008	control knob bezel	x
	N720-0055	side burner supply tube	x
47	N475-0183-GY1SG	left/right side panel cabinet enclosure	x
48	N160-0022	clip door pivot pin	x
49	N475-0293-M06	door panel	x
50	N325-0062	door handle	x
51	N570-0073	1/4-20 x 3/8" screw	x
52	N590-0147-GY1SG	bottom shelf	x
53	N655-0124-GY1SG	front cabinet support	x
54	N475-0271-GY1SG	rear cart panel	x
55	N585-0064P	heat shield	x
56	N105-0013	bushing	x
57	N105-0011	door bushings	x
58	N655-0094P	tank ring support	p
59	N430-0002	magnetic catch	x
	N370-0636	main assembly blister pack	x
60	N080-0210	magnet bracket	x
61	N750-0021B	wiring harness led	x
62	N190-0001	battery pack	x
	W043-0002	battery "AA"	x
63	N080-0254S	tank inhibitor bracket	p
64	N735-0001	insulated washer	x
65	N105-0001	bushing 7/8"	x
66	N640-0001	hose retainer clip	x
67	N160-0015	propane tank clip	p
68	N130-0012	revolving caster	x
69	N450-0027	locking nut 1/4-20	x
70	N080-0212P	stabilizer brackets	x
71	N590-0164	condiment basket	x
72	N130-0013	non revolving caster	x
73	N585-0078	heat shield lid	x
74	N485-0009	side burner lid clip	x
75	N335-0048-M06	side burner lid	x
76	N010-0612	side burner infra red	x
77	N305-0072	side burner grate	x
78	N010-0618	side burner plate assembly	x

Parts List

Item	Part #	Description	RSIB
79	N570-0042	10-24 x 3/8" screw	x
80	N455-0062	side burner orifice #60	p
	N455-0063	side burner orifice 1.45mm	n
81	N160-0016	side burner hose/orifice retainer clip	x
82	N240-0026	side burner electrode	x
83	N710-0063	side burner drip pan	x
84	N185-0003	ice bucket	x
85	N357-0013	side burner igniter	x
	N750-0016	side burner igniter wire	x
86	N660-0002	switch light	x
87	N120-0019-GY0TX	cap door top/bottom	x
88	N570-0099	#14 x 3/4" screw	x
89	N485-0016	door pivot pin top	x
90	N485-0017	door pivot pin bottom	x
91	N385-0226	LEGEND logo	x
92	N570-0013	#8 x 5/8" screw	x
	64485	rotisserie kit	ac
	63488	vinyl cover	ac
	56018	stainless steel griddle	ac
	67730	charcoal tray	ac
	62007	replacement grease trays foil (5 pieces)	ac

p - propane units only n - natural gas units only
x - standard ac - accessory

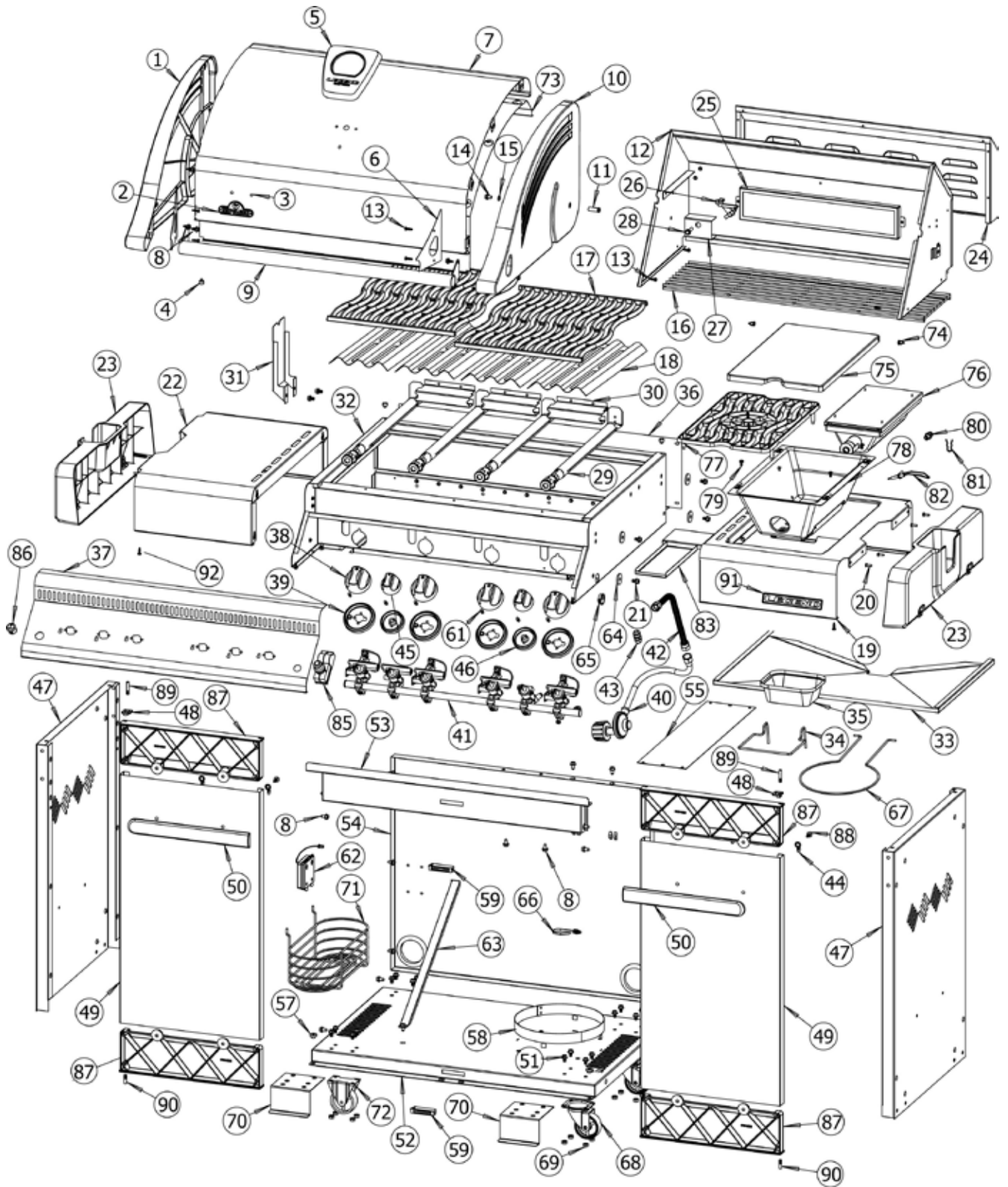



FAX TO: 705 727 4282

ACCESSORIES & PARTS ORDER FORM

PLEASE PRINT CLEARLY

CONTACT NAME: _____

SHIP TO : _____

TEL : _____

FAX : _____

EMAIL: _____

VISA OR MASTERCARD # : _____ EXPIRY DATE: _____

SIGNATURE: _____

QUANTITY	PART NUMBER	DESCRIPTION

TAXES MAY APPLY
SHIPPING EXTRA

IF CONFIRMATION IS REQUIRED PLEASE INCLUDE A FAX NUMBER OR EMAIL ADDRESS