

Installation Manual **COLOR SCANNING SONAR FSV-24/24S**

SAFETY INSTRUCTIONS	i
SYSTEM CONFIGURATION	iii
EQUIPMENT LISTS	v

1. MOUNTING THE EQUIPMENT..... 1-1

1.1 Mounting the Hull Unit.....	1-1
1.2 Mounting the Display Unit	1-8
1.3 Mounting the Transceiver Unit.....	1-14
1.4 Mounting the Power Supply Unit	1-14
1.5 Grounding the Equipment	1-15
1.6 Installing Attachment Flange (option)	1-15
1.7 Mounting the Cable for Extension Kit (option)	1-18
1.8 Attachment Kit (option).....	1-19

2. WIRING..... 2-1

2.1 How to Use the Crimping Tool, Pin Extractor	2-1
2.2 Location of Connectors	2-2
2.3 Monitor Unit	2-4
2.4 Processor Unit	2-8
2.5 Transceiver Unit.....	2-14
2.6 Power Supply Unit	2-17
2.7 Cable for Extension Kit.....	2-17

3. ADJUSTMENT AND CHECK..... 3-1

3.1 Hull Unit Check	3-1
3.2 Heading Adjustment.....	3-4
3.3 Configuring Own Ship Mark	3-6
3.4 Other SYSTEM Menu Items.....	3-8
3.5 CONE Board Setting in the Processor Unit	3-12
3.6 DIP Switch Setting	3-13
3.7 Testing TX/RX Independently at hull unit.....	3-15

4. CONNECTING THE EXTERNAL INTERFACE CS-120A..... 4-1

Check List.....	AP-1
------------------------	-------------

PACKING LISTS	A-1
----------------------------	------------

OUTLINE DRAWINGS	D-1
-------------------------------	------------

INTERCONNECTION DIAGRAMS.....	S-1
--------------------------------------	------------



ECF

(Elemental Chlorine Free)

The paper used in this manual
is elemental chlorine free.

© **FURUNO ELECTRIC CO., LTD.**

9-52 Ashihara-cho,
Nishinomiya, 662-8580, JAPAN

Telephone : +81-(0) 798-65-2111

Fax : +81-(0) 798-65-4200

• FURUNO Authorized Distributor/Dealer

All rights reserved. Printed in Japan

Pub. No. IME-13180-L

(YOSH) FSV-24/24S

A : APR. 2001

L : JUN. 15, 2007



* 0 0 0 8 0 9 1 6 7 1 4 *



SAFETY INSTRUCTIONS



DANGER



Keep away from moving shaft of the hull unit.

Gears may cause injury.



WARNING



Do not open the cover unless totally familiar with electrical circuits and service manual.

High voltage exists inside the equipment, and a residual charge remains in capacitors several minutes after the power is turned off. Improper handling can result in electrical shock.

Turn off the power at the switchboard before beginning the installation.

Fire or electrical shock can result if the power is left on.

Do not install the equipment where it may get wet from rain or water splash.

Water in the equipment can result in fire, electrical shock or equipment damage.

Be sure no water leaks in at the transducer installation site.

Water leakage can sink the vessel. Also confirm that the transducer will not loosen by ship's vibration. The installer of the equipment is solely responsible for the proper installation of the equipment. FURUNO will assume no responsibility for any damage associated with improper installation.



WARNING

Install the specified transducer tank in accordance with the installation instructions. If a different tank is to be installed the shipyard is solely responsible for its installation, and it should be installed so the hull will not be damaged if the tank strikes an object.

The tank or hull may be damaged if the tank strikes an object.

If a steel tank is installed on a wooden or FRP vessel, take appropriate measures to prevent electrolytic corrosion.

Electrolytic corrosion can damage the hull.

Be sure that the power supply is compatible with the voltage rating of the equipment.

Connection of an incorrect power supply can cause fire or equipment damage. The voltage rating of the equipment appears on the label above the power connector.



CAUTION



Ground the equipment to prevent electrical shock and mutual interference.

CAUTION

Maximum speed while the transducer is projected and being raised or lowered is as below, to prevent damage to the transducer.

	Projected	Raising/ Lowering
1200 mm stroke	Max. 18 kt	Max. 15 kt
1600 mm stroke	Max. 15 kt	Max. 12 kt

Observe the following compass safe distances to prevent interference to a magnetic compass:

	Standard compass	Steering compass
Processor Unit	1.55 m	1.05 m
Control Unit	0.20 m	0.15 m
Monitor Unit	1.25 m	0.85 m

Other equipment should be positioned at least 7 m away from a magnetic compass.

SYSTEM CONFIGURATION

Standard type

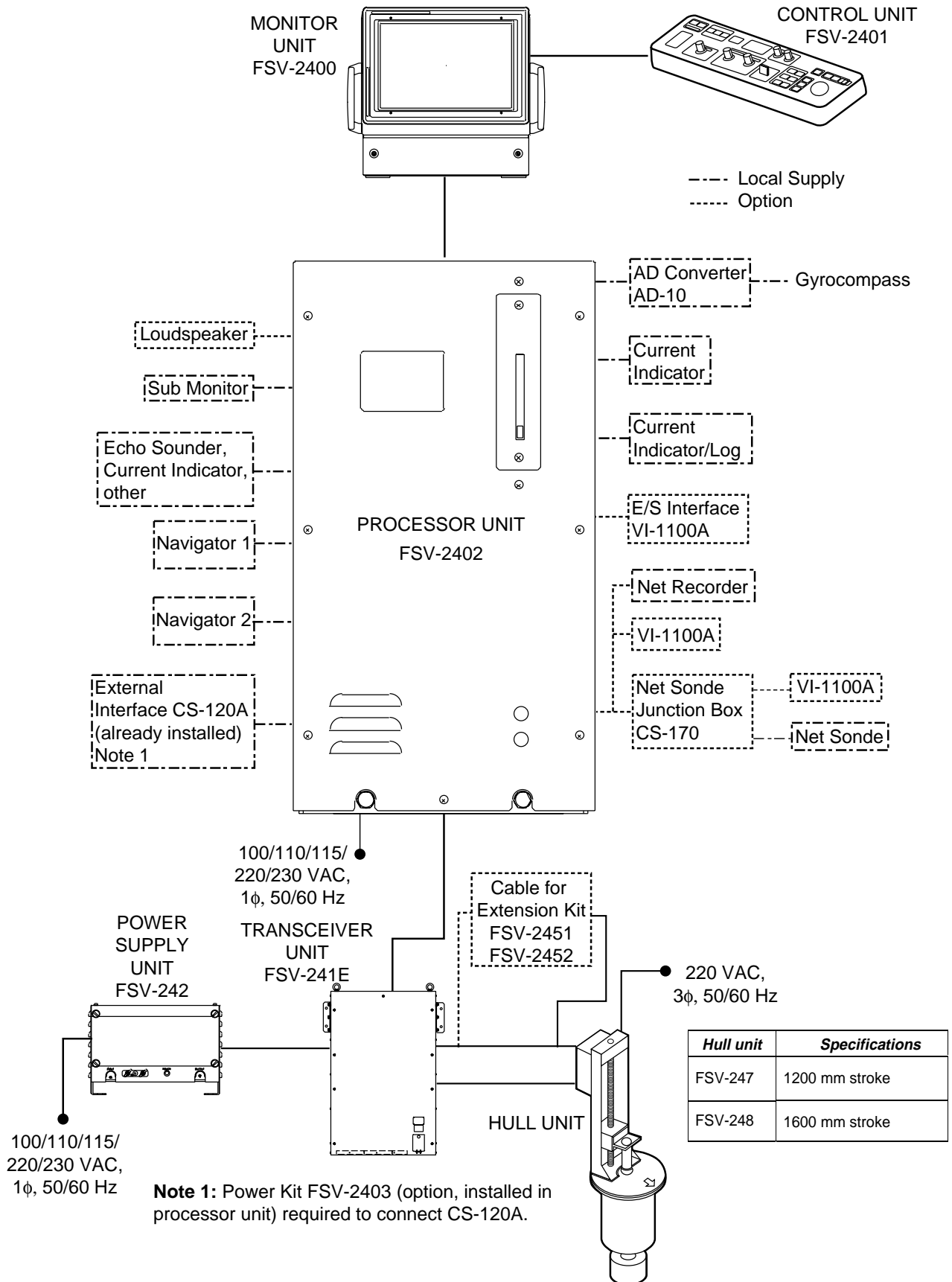

Black box type

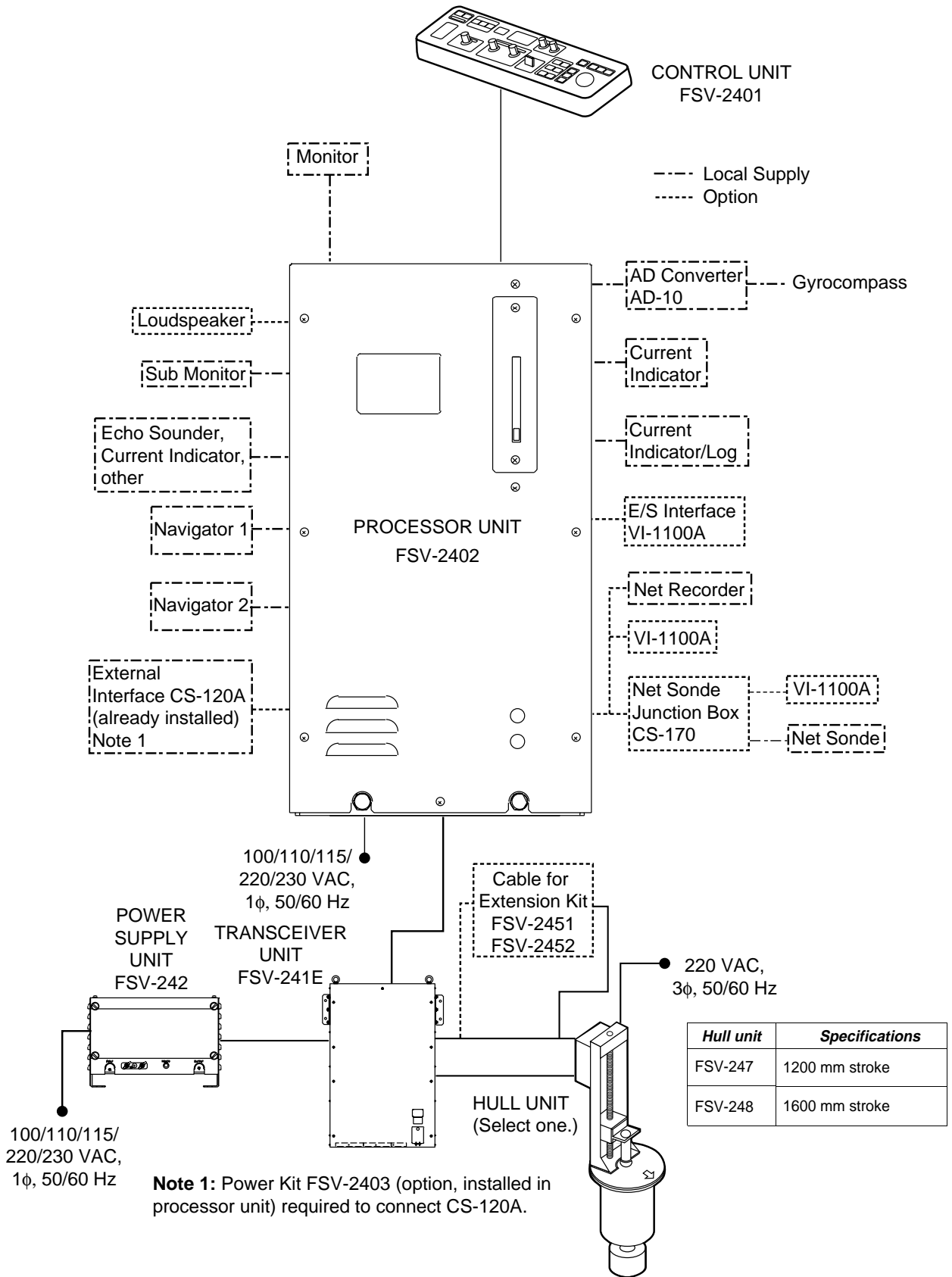

EQUIPMENT LISTS

Standard supply

Name	Type	Code No.	Q'ty	Remarks
Monitor Unit	FSV-2400	-	1	21" color monitor
Control Unit	FSV-2401	-	1	w/cable
Processor Unit	FSV-2402	-	1	For FSV-24
	FSV-2402S	-		For FSV-24S
Transceiver Unit	FSV-241E	-	1	
Power Supply Unit	FSV-242	-	1	
Hull Unit	FSV-247	-	1*	1200 mm stroke
	FSV-248	-		1600 mm stroke
Installation Materials	CP10-05100	000-067-027	1 set*	For system with monitor CP10-04501, 10S2074, CP10-04502, CP10-04503, CP10-04505, CP10-04506, 10S2078
	CP10-05110	000-067-028		For system with monitor CP10-04501, 10S2075, CP10-04502, CP10-04503, CP10-04505, CP10-04506, 10S2078
	CP10-05120	000-067-029		For system without monitor CP10-04502, CP10-04503, CP10-04505, CP10-04506, 10S2078
Spare Parts	SP10-02600	000-066-999	1 set	SP10-02601, SP1-02602, SP10-02603
Accessories	FP10-02200	000-067-006	1 set	FP03-06201, FP10-02202, FP10-02201, FP10-02203, dust cover
	FP10-02210	000-067-007		For system without monitor FP10-02201, FP10-02203

*: Select one

Options

Name	Type	Code No.	Q'ty	Remarks
Monitor Unit	FSV-2400-10	-	1	With CP10-04501, FP03-06201, FP10-02202, Dust cover & 10S5207 (10 m cable)
	FSV-2400-30	-		With CP10-04501, FP03-06201, FP10-02202, Dust cover & 10S2075 (30 m cable)
Control Unit	FSV-2401-E-5	-	1	With FP10-02201 & 5 m cable
	FSV-2401-E-10	-		With FP10-02201 & 10m cable
37 cores Cable	10S1258	000-101-006	1	Specify length
E/S Interface	VI-1100A	-	1	
Net Zonde Junction Box	CS-170	-	1	For sonde connection
Power Supply Kit	FSV-2403	000-067-013	1	For connection of CS-120A
NMEA Cable	MJ-A6SPF0012-100C	000-154-037-10	1	10 m, 6P-6P
	MJ-A6SPF0012-050C	000-154-053-10	1	5 m, 6P-6P
E/S cable	VVS 0.3X8C *6M*	000-555-043	1	6 m
Attachment Flange	OP10-22	000-067-037	1	For CSH-20 1200 mm stroke w/flange, FSV-247
	OP10-23	000-067-038	1	For CSH-20 1600 mm stroke w/flange, FSV-248
Attachment Kit	OP10-24	006-943-530	1	Using retraction tank of FSV-243E/244E for FSV-247/248
Loudspeaker	SEM-21Q	000-144-917	1	
Hood	FP03-06503	008-490-970	1	For monitor unit
Installation Material for interface	CP10-04801	006-934-240	1	
Cable for Extension Kit	FSV-2451	000-067-030	1	5 m cable extension, 10S2138*5m*, 10S2139*5m*, 10S2144*12.9m*
	FSV-2452	000-067-031		15 m cable extension, 10S2138*15m*, 10S2139*15m*, 10S2145*22.9m*

1. MOUNTING THE EQUIPMENT

1.1 Mounting the Hull Unit

Note1) The rise/lower control box of the hull unit contains motion sensor.
Therefore, never drop the hull unit.

Note2) Take care the handling of the transducer. Do not give a strong shock.

1.1.1 Location of hull unit

Decide the location of the hull unit through consultation with the dockyard and ship owner. When deciding the location, the following points should be taken into account.

- Select an area where propeller noise, cruising noise, air bubbles and interference from turbulence are at a minimum. Generally, the point at $1/3$ to $1/2$ of the ship's length from the bow on or near the keel is optimum. On-the-keel installation is advantageous for minimizing oil consumption in comparison with off-the-keel. If the hull unit can not be installed on the keel, the center of the retraction tank should be within 600 mm of the keel to prevent a rolling effect. **For large ship with deep draft**, the hull unit can be installed at the bow.

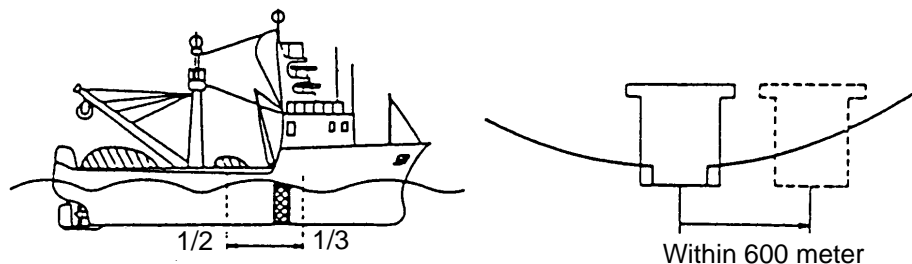

Hull unit mounting location

- Select a place where the hull bottom is flat and the draft is sufficiently deep. Normally, the transducer should protrude at least 500 mm beyond the keel to minimize the effect of air foam and bubbles.
- Select a place where interference from other equipment is minimal. The hull unit should be at least 2.5 m away from the transducers of other equipment.
- No obstacle should be in the fore direction since it causes a shadow zone and aerated water, resulting in poor sonar performance.
- The space shown in the figure on the next page is required around the hull unit for wiring and maintenance.
- If the ambient temperature of the unit is below 0°C , provide the sonar compartment with a heater to keep the temperature above 0°C .

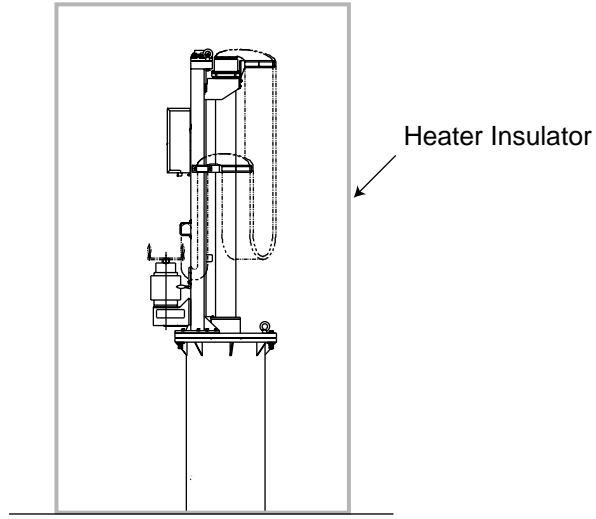
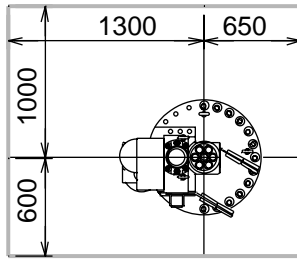

Maintenance space, example sonar compartment

Note: After mounting the equipment, install stays for anti-vibration. See page 1-7.

1.1.2 Shortening the retraction tank

The retraction tank is 1300 mm in length when supplied. Shorten the tank as necessary so that the transducer is placed well below the keel when it is fully lowered. The following table provides guidelines for shortening the tank. Refer also to the retraction tank installation drawing at the back of this manual.

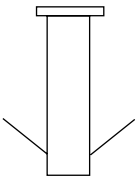
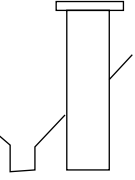
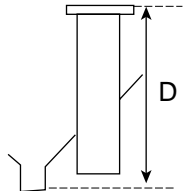
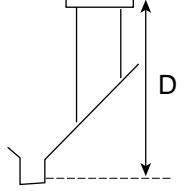
Installation Method				
XDCR Travel				
1200 mm stroke	Remove 130 thru 140 mm from the bottom.	Same as left.	Remove 130 to 140 mm from the bottom. Note that the length "D" must be less than 1170 mm.	Same as left.
1600 mm stroke	Remove less than 140 mm from the bottom.	Same as left.	Remove less than 140 mm from the bottom. Note that the length "D" must be less than 1570 mm.	Same as left.

Guidelines for shortening the retraction tank

Note 1: In the 1200 mm stroke type hull unit, the transducer will not fully protrude unless the tank is shortened by at least 130 mm from the bottom, and cannot be fully retracted if more than 140 mm is removed.

Note 2: In the 1600 mm stroke type hull unit, the transducer cannot be fully retracted if the tank is removed more than 140 mm.

Note 3: When 140 mm is removed and "D" is minimum, the effect of air foam is minimized because the transducer fully protrudes in water.

1.1.3 Remarks for installation of retraction tank

1. Make, if possible, the installation location a double bottom structure.
2. Install, if possible, the tank on the keel where the tank can be most firmly fixed.
3. Install the reinforcement ribs as near as possible to the top of the retraction tank, allowing space for tightening of bolts and nuts.

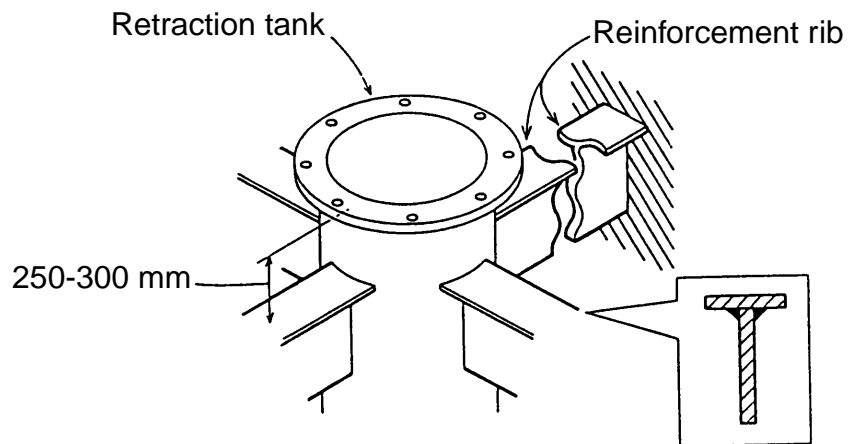

How to install reinforcement ribs

4. Add a doubling plate at the location where the retraction tank is welded to the hull bottom. The size of the doubling plate is normally 1300 mm in diameter so that it may lie across two bottom frames.
5. Make the bow mark on the attachment flange with a chisel.

1.1.4 Installing hull unit on retraction tank

After welding the retraction tank and allowing sufficient time for cooling, install the hull unit as follows.

1. Clean the hull unit flange, the O-ring and O-ring groove. Coat them with a slight amount of grease. Place the O-ring in position on the tank flange.
2. Orient the hull unit so that the bow mark (inscribed) on its flange points toward the ship's bow. Note that heading adjustment in the display unit is required if the bow mark does not face the ship's bow.
3. Confirm that the O-ring is in position. Place the hull unit on the tank.
4. Coat every bolt, washer and nut with a slight amount of grease to ease removal. Fasten the hull unit to the retraction tank with flat washers, spring washers and hex bolts.
5. Reinforce the hull unit against vibration by extending stays to the ship's hull from the two eye bolts at the top of the hull unit, referring to the figure at the top of page 1-7.

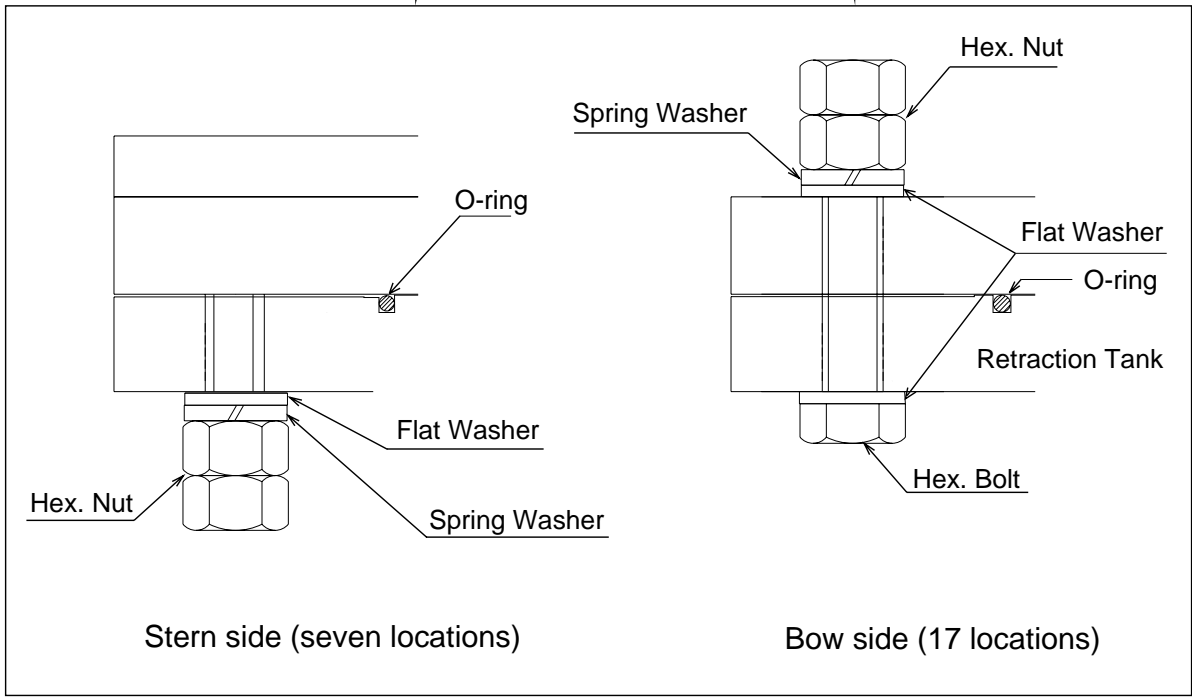
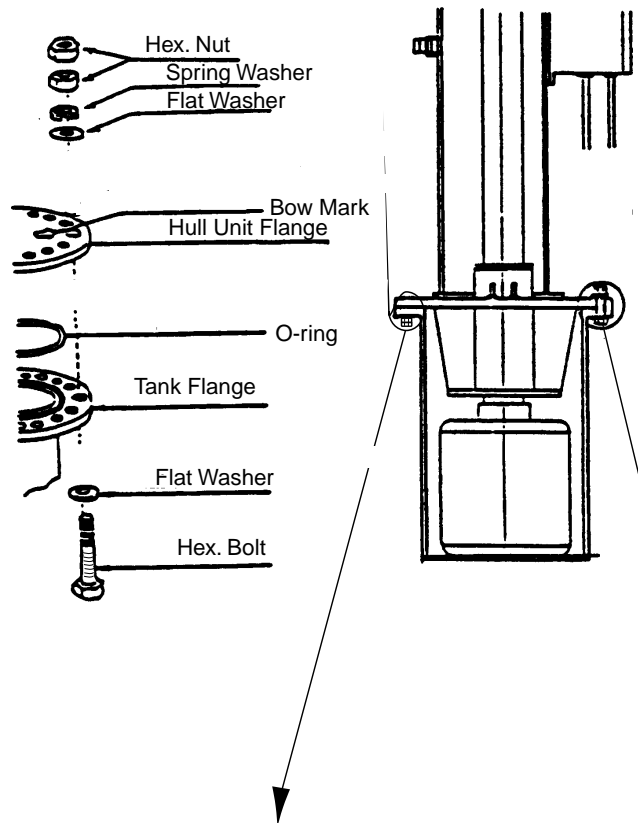

Installation of hull unit

1.1.5 Installing stays (anti-vibration measure)

Install stays from the top of the hull unit to the ship's hull. The stays should be angle iron with a size of 75X75X9 mm or more and at least two pieces should be used; one each to ship's bow and stern directions. Install if possible, two more stays in ship's transverse direction.

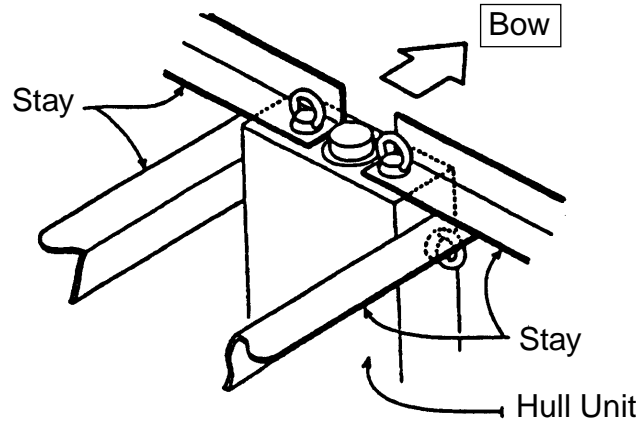

Proper installation of stays

Do not install the stays as shown below. Vibration-resistance effect is reduced since vibration is applied to the stays as rotation force. Install them horizontally.

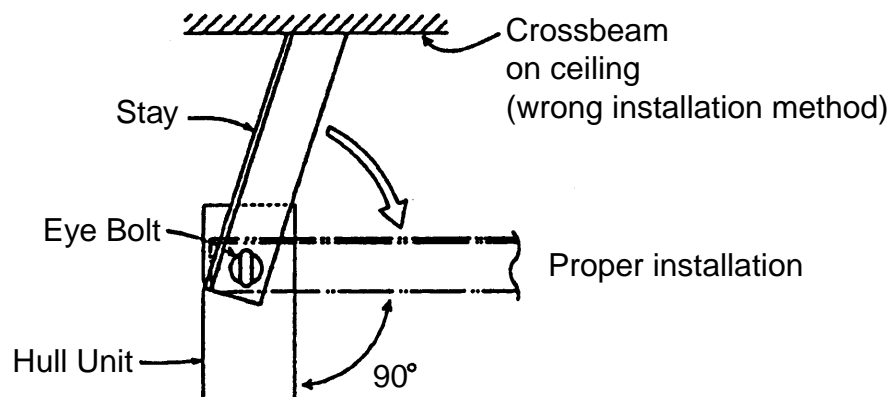

Proper and wrong installation of stay

Note: Install stays as shown above, otherwise the transducer may be damaged.

1.2 Mounting the Display Unit

The display unit is composed of the processor, monitor and control units.

1.2.1 Processor unit

Mounting considerations

When selecting a mounting location, keep in mind the following points:

- The processor unit must be mounted upright.
- Locate the unit out of direct sunlight and away from heat sources because of heat that can build up inside the cabinet.
- Locate the equipment away from places subject to water splash and rain.
- Be sure the mounting location is strong enough to support the weight of the unit under the continued vibration which is normally experienced on the ship. If necessary reinforce the mounting location.
- Determine the mounting location considering the length of the cables below.
 - a) Signal cable from the transceiver unit
 - b) Monitor cable from the monitor
 - c) Control cable from the control unit (when locally supplied monitor is used)
- Leave sufficient space on the sides and rear of the unit to facilitate maintenance. Also, leave a foot or so of "service loop" in cables behind the unit so it can be pulled forward for servicing or easy removal of connectors.
- Make free space of 400 mm between the processor unit and bulkhead to prevent cable stress.

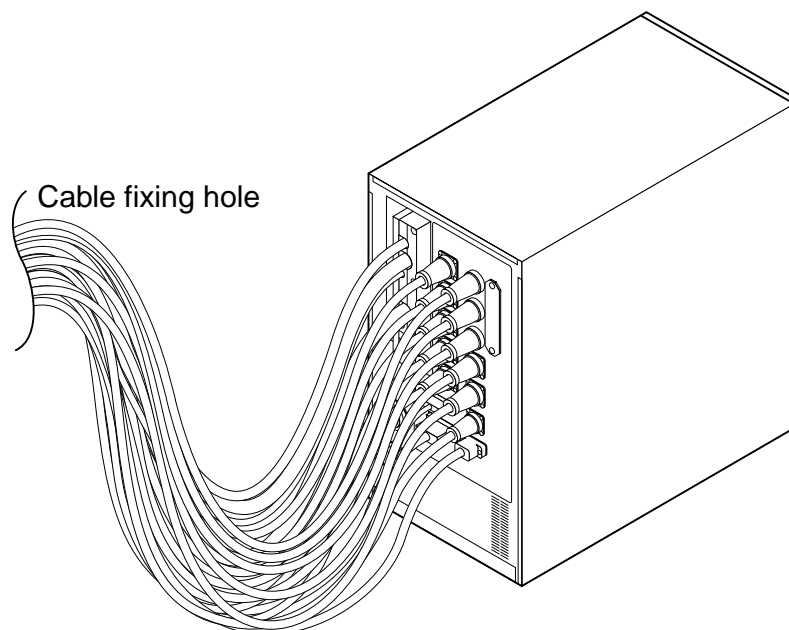

Mounting procedure

1. Unfasten two bolts from the bottom of the front side of the processor unit, and pull the unit toward you to separate the unit from the mounting base.
2. Fasten six bolts (M6x20, supplied as installation material) to install the mounting base.
3. Place the processor unit in front of the mounting base.
4. Push the unit forward until it touches the end of the mounting base.
5. Refasten two bolts removed at step 1 to fix the unit.

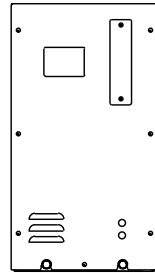

Front view

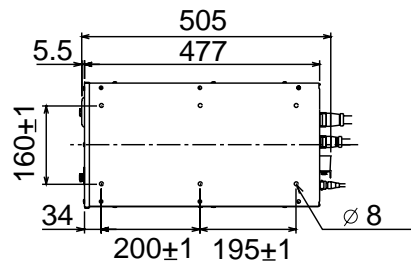

Top view

Processor unit

1.2.2 Monitor unit

Mounting considerations

- The monitor unit is designed for mounting on a tabletop.
- Locate the monitor unit where it can be easily operated while viewing the screen and operating the control unit.
- Locate the monitor unit out of direct sunlight and away from heat sources because of heat that can build up inside the cabinet.
- Locate the equipment away from places subject to water splash and rain.
- Be sure the mounting location is strong enough to support the weight of the unit under the continued vibration which is normally experienced on the ship. If necessary reinforce the mounting location.
- The length of the monitor cable which runs between the processor unit and the monitor unit is 10 m. Keep this distance in mind when selecting a mounting location.
- Leave sufficient space on the sides and rear of the unit to facilitate maintenance.

Mounting procedure

1. Drill four holes of 12 mm in diameter in the mounting location, referring to the outline drawing for mounting dimensions.
2. Unfasten two M4X10 screws to dismount the front cover.
3. Unfasten two sets of M10 bolts, plain washers and spring washers to separate the monitor from the mounting base.
4. Pull the monitor forward about four centimeters and then lift it to separate it from the mounting base.
5. Fasten the mounting base to the mounting location with M10 bolts, nuts and washers (local supply).
6. Lay the monitor on the top of the mounting base, making sure the rear pin on the monitor is mated to the slit in the mounting base. Fix the monitor to the mounting base with the two sets of bolts, nuts and washers unfastened at step 3.
7. Close the front cover.

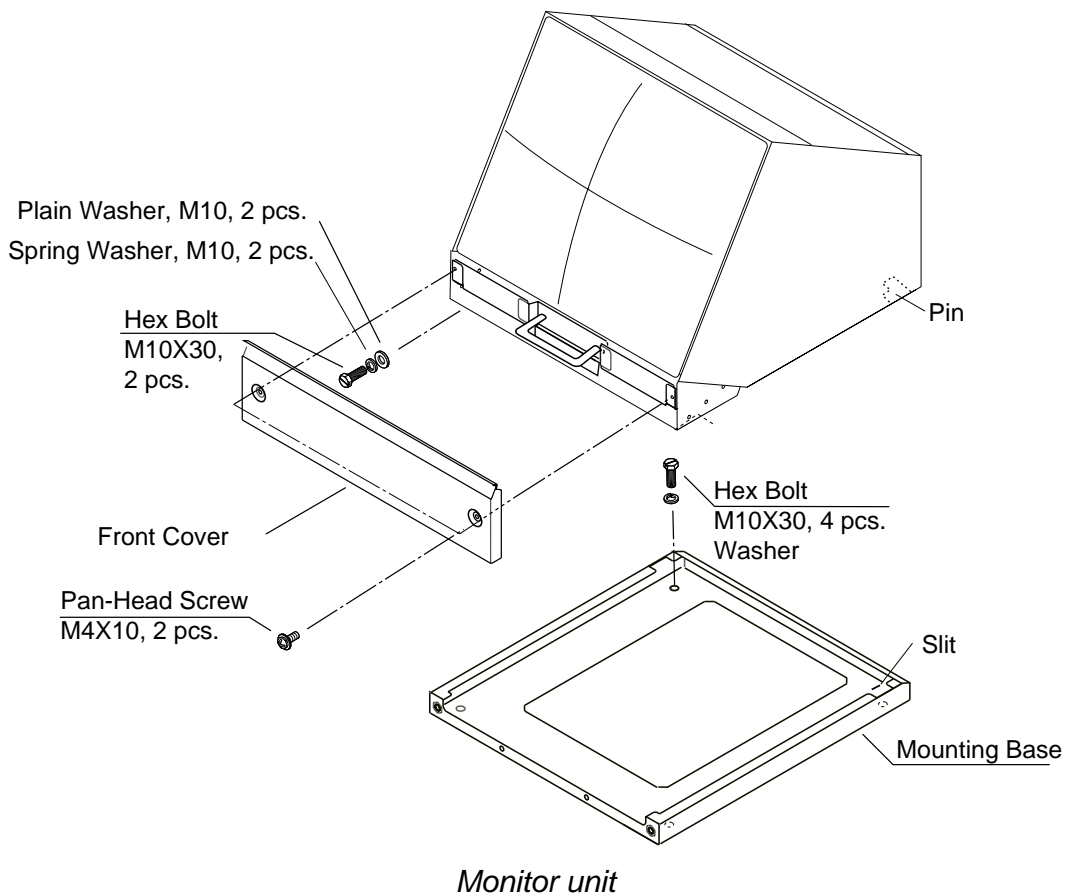

Attaching the CRT filter

1. Attach two spacer (5x2.5, supplied) with screws (M5x10, supplied) to the location shown below.
2. Screw two hood retainer (supplied) into the filter (supplied).
3. Turn two washers (Φ12, supplied) into two hood retainer attached at step 2.
4. Attach the filter to the monitor unit as shown below.

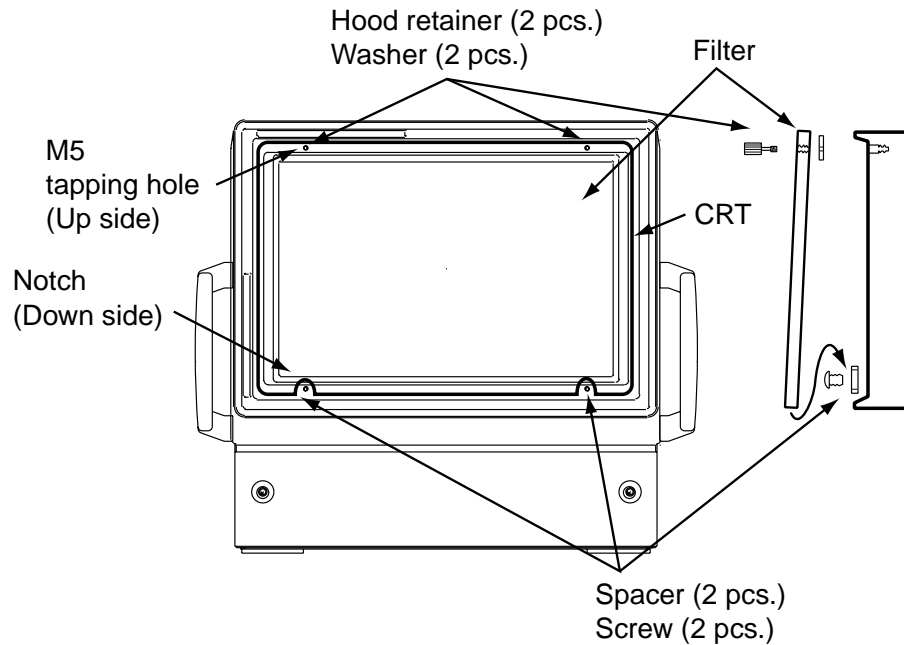

How to attach the hood

1.2.3 Control unit

The control unit may be mounted on a tabletop, with or without the KB fixing plate (supplied), which mounts the control unit at an angle. If the control unit is not to be fastened, lay it atop the rubber feet (supplied as accessory).

(1) Rubber feet

Attach four rubber feet to the bottom of the control unit if it is not going to be permanently fixed.

(2) Fixing without KB fixing plate

- 1) Drill four mounting holes of 6 mm diameter to fasten the control unit, referring to the outline drawing at the back of this manual.
- 2) Make a cutout in the mounting location large enough to accommodate the name plate so the control unit will lie flat. For dimensions, see the outline drawing at the back of this manual.
- 3) Fix the control unit with four bolts (M5) from under the tabletop. (M5 bolts with a sufficient length for the thickness of the tabletop should be provided locally.)

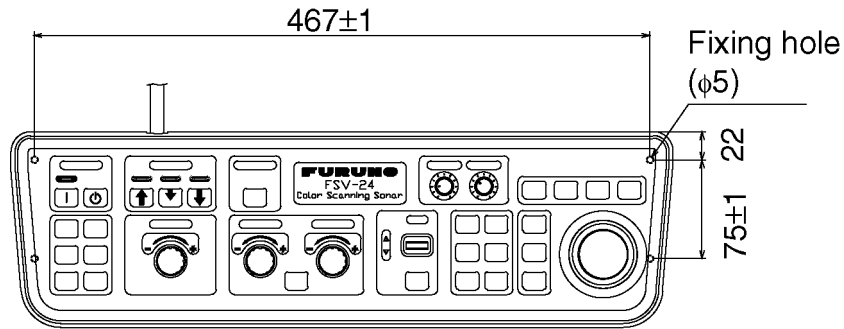

Control unit

(3) Using KB fixing plate mounting

1. To fix the control unit to a desired location at an angle, fasten the KB fixing plate to the control unit and desired location with two upset screws (M5X10, supplied) and two tapping screws ($\phi 6.5$, local supply) as below.

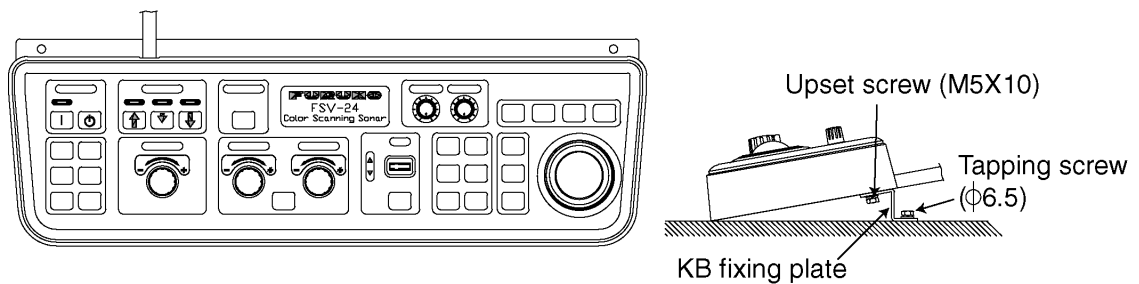

How to attach KB fixing plate

2. Set dust cover (supplied) to the control unit.

Passing the cable through the bottom of the control unit

For permanent mounting ((2) and (3) above), the control cable can be passed through the bottom of the control unit. Do the steps in below.

1. Unfasten eight screws (M4) to remove the cover from the bottom of the control unit.
2. Unscrew two screws (M4x10) to remove the cable clamp.
3. Disconnect two connectors J1 and J2 from the circuit board.
4. Attach the cable to the control unit cover with the cable clamp (removed at step 2), two flat head screws (M4), flat washers, spring washers and nuts (hardware: supplied).

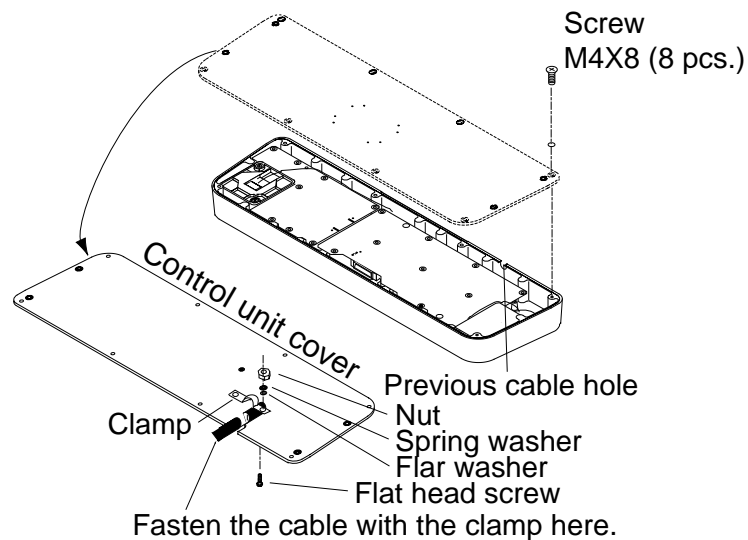

Control unit, cover removed

5. Re-connect two connectors (disconnected at step 3) to the previous locations.
6. Fasten eight screws to attach the control unit cover.
7. Attach the connector seal (supplied) to the hole at the rear of the control unit.
8. Drill a hole to pass the cable from the bottom of the control unit through the tabletop. The diameter of the hole should be 30 mm.
9. Attach the connector seal (supplied) to the hole at the bottom of the control unit when the above modification is not done.
10. Fix the control unit referring to (2) or (3) on the previous page.

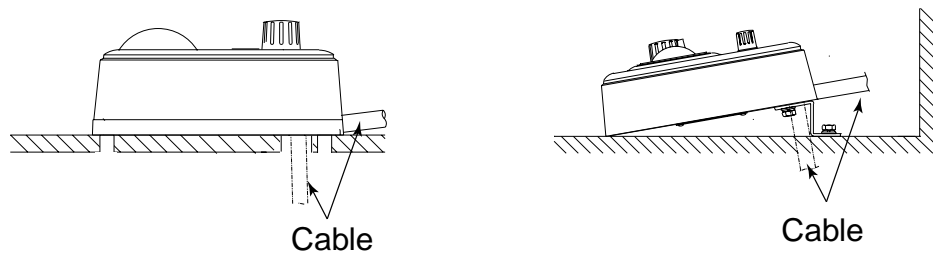

w/o KB fixing plate

w/ KB fixing plate

Control unit, side view

1.3 Mounting the Transceiver Unit

The transceiver unit should be mounted on a mounting base (shipyard supply) whose dimensions are as shown in the outline drawing of the transceiver unit at the back of this manual. The transceiver unit should be reinforced against vibration by stays extending from the eyebolts on the top of the unit. Fasten 10 bolts (M12, local supply) at the bottom and back of the transceiver unit to fasten it to the mounting location.

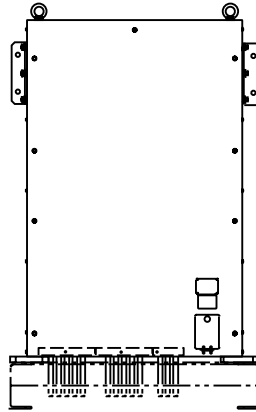

Transceiver unit

1.4 Mounting the Power Supply Unit

Weld four bolts (M8, local supply) referring to the outline drawing at the back of this manual. Sets the power supply unit to the bolts welded, and then turn four nuts (local supply) to fix.

Note: If necessary, reinforce the bulkhead since the unit weights 25 kg (57.3 lbs).

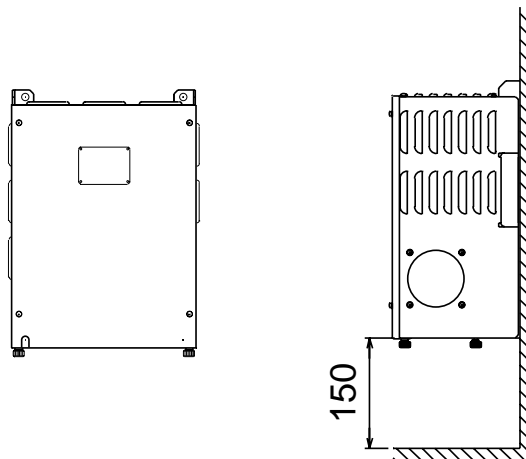

Power supply unit

1.5 Grounding the Equipment

The power supply unit, processor unit and hull unit have protective grounding. Ground the units with a ground wire (IV-8SQ, local supply) or copper strap to prevent electrical shock. Ground the monitor unit and transceiver unit with a ground wire (IV-8SQ, local supply) or copper strap fastened to the ship's superstructure. For the power supply unit, transceiver unit and junction box (option) use a supplied copper strap.

Grounding for junction box

Use one of four butterfly bolts to ground the junction box.

1.6 Installing Attachment Flange (option)

The tank for the CSH-20 series may be used by installing the optional attachment flange.

In case that 1200 mm stroke was used in CSH-20 series

Attachment flange set

For FSV-247: OP10-22 (Code no: 000-067-037)

Name	Type	Code No.	Q'ty	Remarks
Attachment flange	10-077-5801	100-303-601	1	
O-ring	CO 0318A (V585)	000-166-370-10	1	
Hex. bolt	M20x120 SUS304	000-162-825-10	24	
Hex. nut	M20 SUS304	000-863-116	48	
Flat washer	M20 SUS304	000-864-136	48	
Spring washer	M20 SUS304	000-864-270	24	

In case that 1600 mm stroke was used in CSH-20 series

Attachment flange set

For FSV-248: OP10-23 (Code no. 000-067-038)

Name	Type	Code No.	Q'ty	Remarks
Attachment flange	10-077-5802	100-303-610	1	
O-ring	CO 0318A (V585)	000-166-370-10	1	
Hex. nut	M20 SUS304	000-863-116	48	
Flat washer	M20 SUS304	000-864-136	24	
Spring washer	M20 SUS304	000-864-270	24	

Procedure

1. Clean the hull unit flange, O-ring and O-ring groove. Coat them with a slight amount grease.
2. (1200 mm stroke) Use 24 hex. bolts, 48 hex nuts, flat washers and spring washers to fasten the attachment flange to retraction tank.
(1600 mm stroke) 24 bolts have already been fitted. Use the bolts, 48 hex. nuts, flat washers and spring washers to fasten the attachment flange to retraction tank.
3. Place the O-ring in position on the attachment flange.

To install the attachment flange and the hull unit, see "1.1.4 Installing hull unit on retraction tank" on page 1-5.

The sectional view for the attachment flanges are shown on the next two pages.

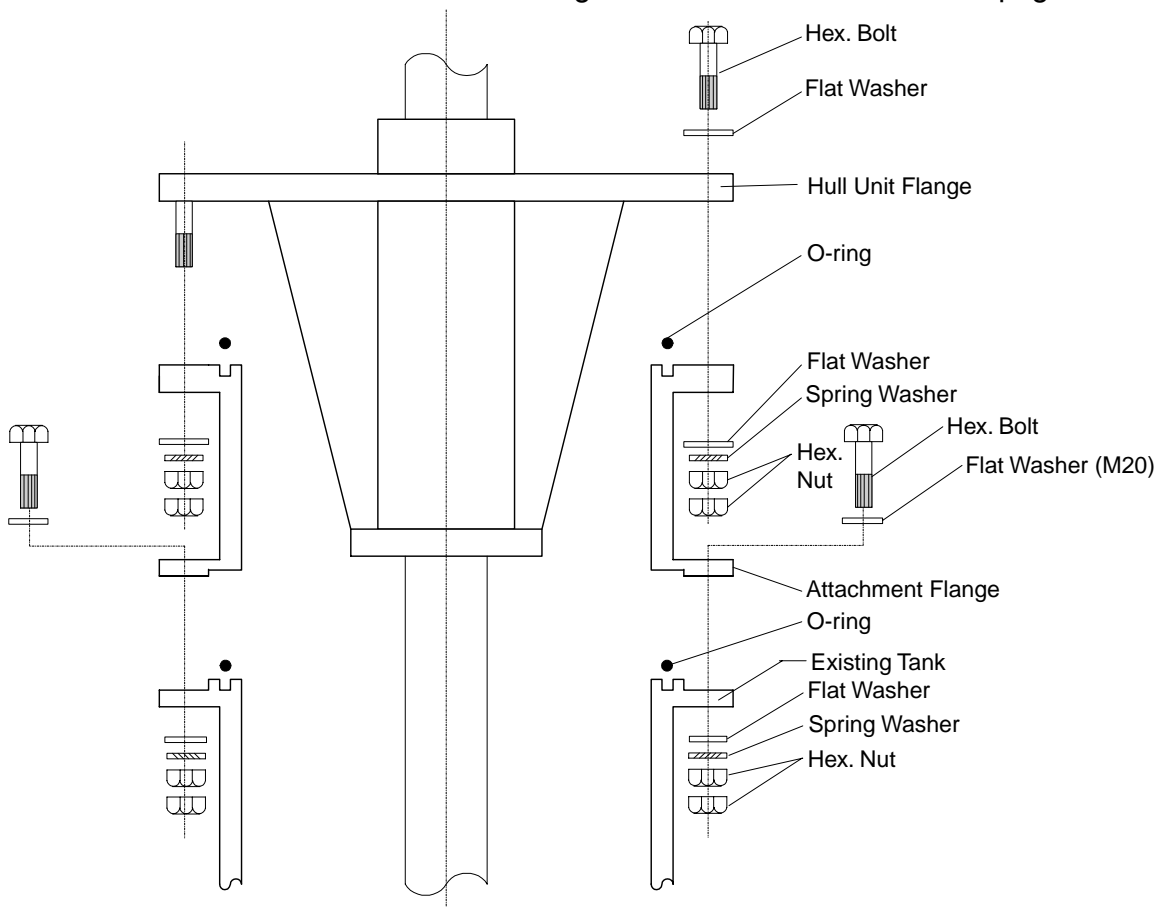

Attachment flange for 1200 mm stroke transducer, sectional view

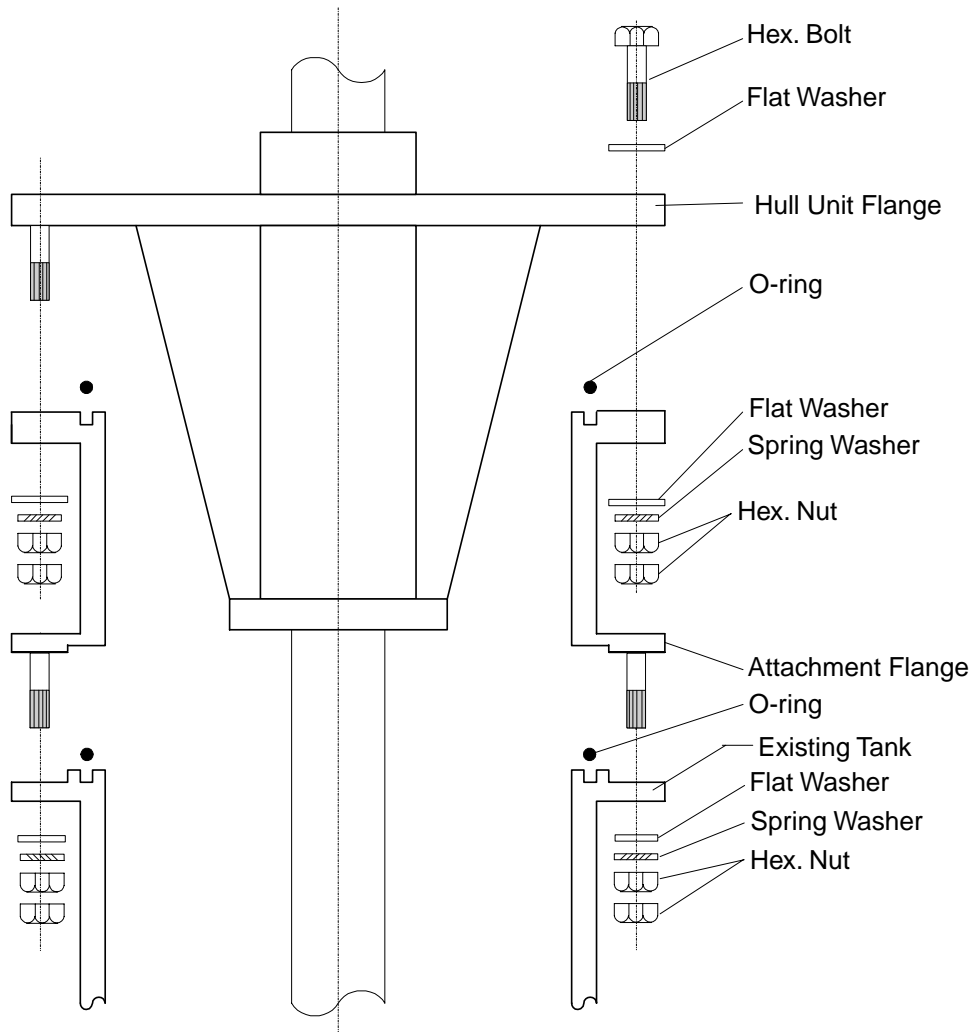

*: FSV-244E only

Attachment flange for 1600 mm stroke transducer, sectional view

1.7 Mounting the Cable for Extension Kit (option)

For extension of the transducer cable between the hull unit and the transceiver unit, use the extension cable kit (option). The kit is available in 5 and 15 meter lengths.

Name: Cable for Extension Kit, Type: FSV-2451, Code No.: 000-067-030

Name	Type	Code No.	Qty	Remarks
Junction box	FSV-245	000-067-032	1	
Cable assembly	10S2138*5m*	000-145-350	1	
	10S2139*5m*	000-145-354	1	
	10S2144*12.9m*	000-145-360	1	

Name: Cable for Extension Kit, Type: FSV-2452, Code No.: 000-067-031

Name	Type	Code No.	Qty	Remarks
Junction box	FSV-245	000-067-032	1	
Cable assembly	10S2138*15m*	000-145-351	1	
	10S2139*15m*	000-145-355	1	
	10S2144*22.9m*	000-145-361	1	

Fasten the Junction Box to bulkhead with 4 bolts (M8, local supply).

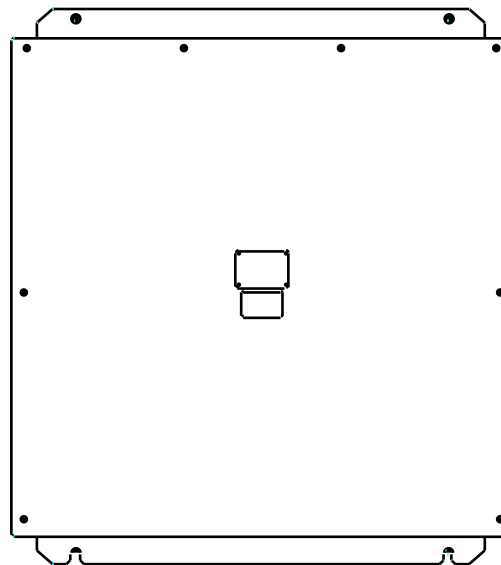

Junction box

1.8 Attachment Kit (option)

When using the retraction tank of FSV-243E/244E for FSV-247/248, the optional attachment kit OP10-24 is necessary.

Name: Attachment kit Type: OP10-24 Code no.: 006-943-530

Name	Type	Code No.	Qty
Insulation gasket	MS-1000-67	000-857-220	24
Insulation gasket (2)	MS-1000-68	000-857-221	24

1. Clean the hull unit flange, the O-ring and O-ring groove. Coat them with a slight amount of grease. Place the O-ring in position on the tank flange.
2. Lay the insulation gasket (1) on the top of the tank flange.
3. Orient the hull unit so that the bow mark (inscribed) on its flange points toward the ship's bow. Note that heading adjustment in the display unit is required if the bow mark does not face the ship's bow.
4. Confirm that the O-ring and the insulation gasket (1) are in position.
5. Place the hull unit on the tank.
6. Seven of the 24 bolt holes on the hull unit flange have already been fitted with bolts (stern side). Insert the insulator gasket (2) into the bolt holes of the tank flange to which these seven bolts are fitted.
7. Coat every bolt, washer and nut with a slight amount of grease to ease removal. Fit the insulation gasket (2) into the bolt holes of the tank flange. Fasten the hull unit to the retraction tank with insulation gasket (2), flat washers, spring washers and hex bolts.
8. Reinforce the hull unit against vibration by extending stays to the ship's hull from the two eye bolts at the top of the hull unit, referring to the figure at the top of page 1-7.

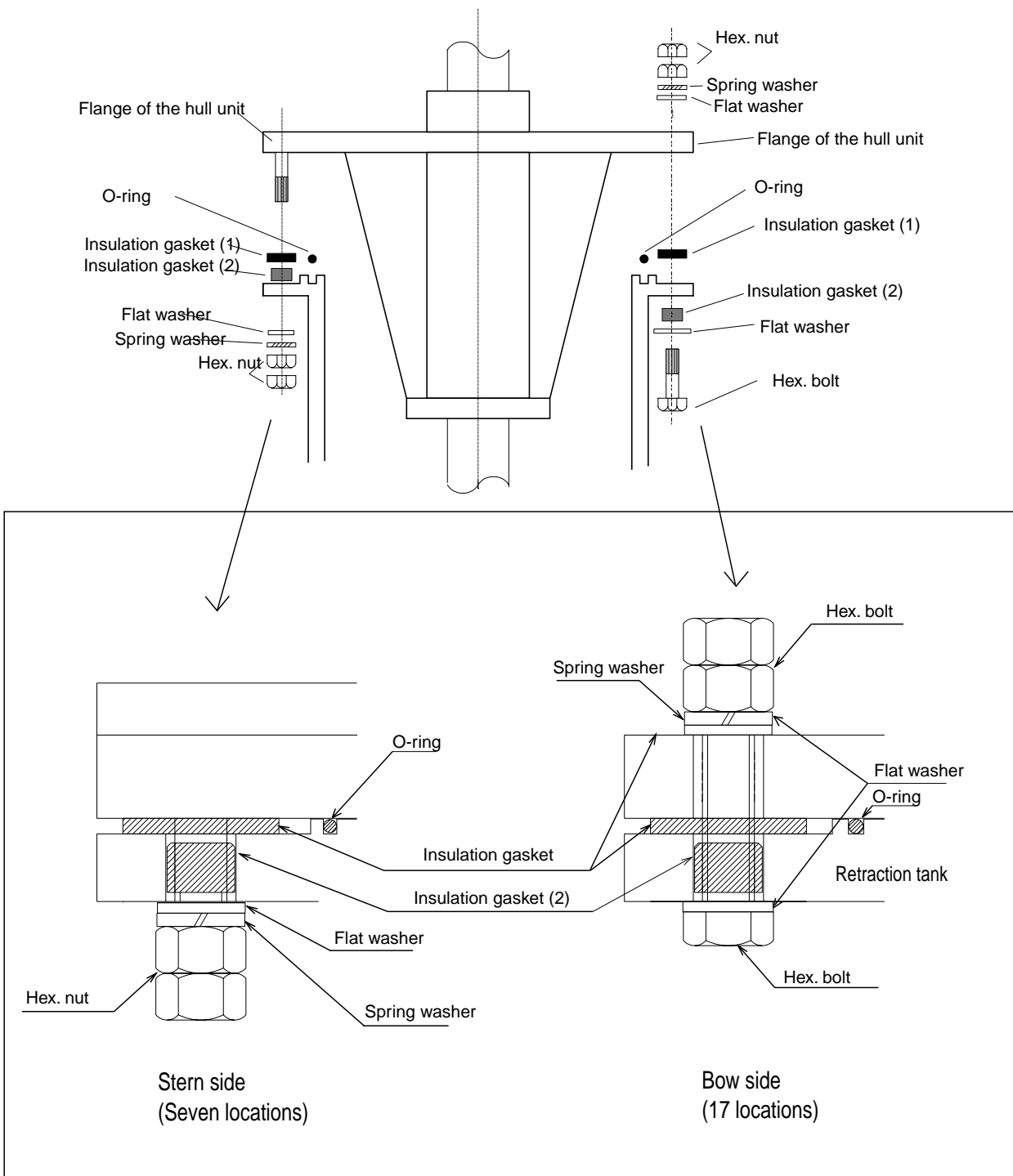

Using the optional attachment kit

2. WIRING

2.1 How to Use the Crimping Tool, Pin Extractor

A special crimping tool is necessary for connection of wires to the contact pins of the 38P connector. The pin extractor removes the contact pin from the connector body. This paragraph describes how to crimp and extract the contact pin.



Crimping tool, contact pin, pin extractor

2.1.1 How to use the crimping tool

1. Strip the vinyl sheath of the wire to expose the core by 3 mm to 4 mm.
2. Hold the crimping tool horizontally and insert the contact pin with its slit facing downward into the crimp hole on the crimping tool.
3. Insert the wire onto the contact pin and squeeze the handle until the ratchet releases. (The wire should be placed deep enough into the contact pin so that its end comes in contact with the stopper plate of the crimping tool.) With crimping completed, pull the wire while holding the contact pin to make sure that it is tightly fastened.

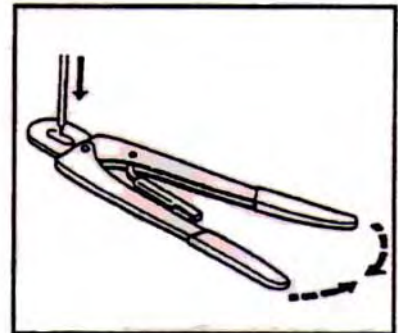

2.1.2 How to use the pin extractor

If a contact pin is inserted into an incorrect hole on the connector body, remove it with the pin extractor.

1. Push the pin extractor into the pin hole from the side opposite to the pin inserting side.
2. Push in the head of the pin extractor. The retaining spring comes free and the contact pin can be removed.

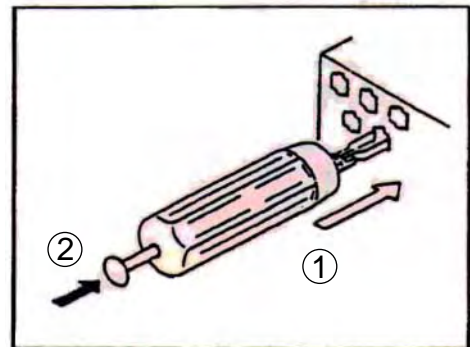

2.2 Location of Connectors

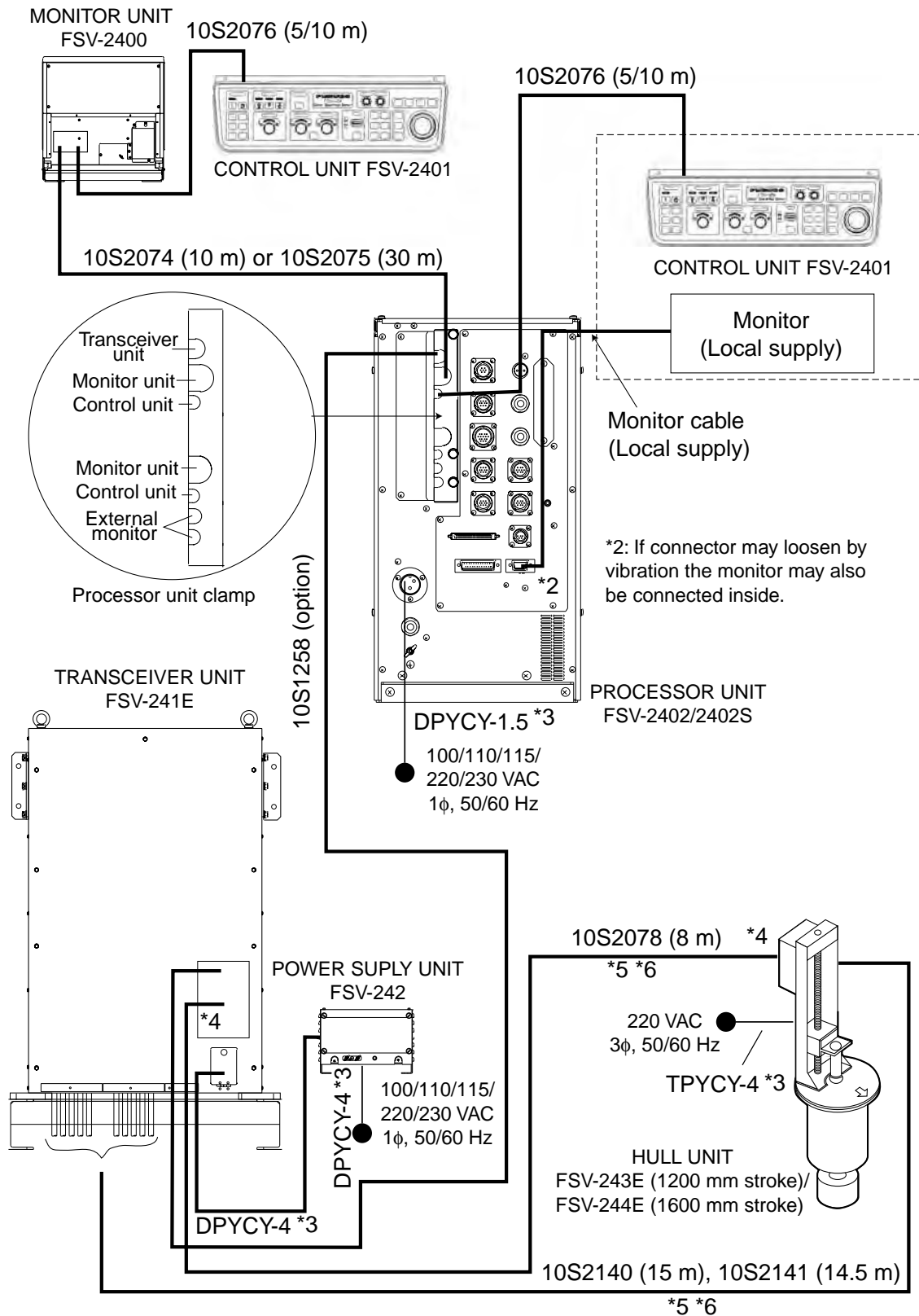

*3: Japan Industrial Standard cable

*4: The same type of connector is fitted at each end, however the connector where the amount of sheath removed is greater should be connected to the transceiver unit.

*5: When running the cables of 10S2078, 10S2140 and 10S2141, refer to next page.

*6: When using cable for extension kit, the length of the cable between the transceiver unit and the hull unit is 10 m or 20 m.

Interconnection

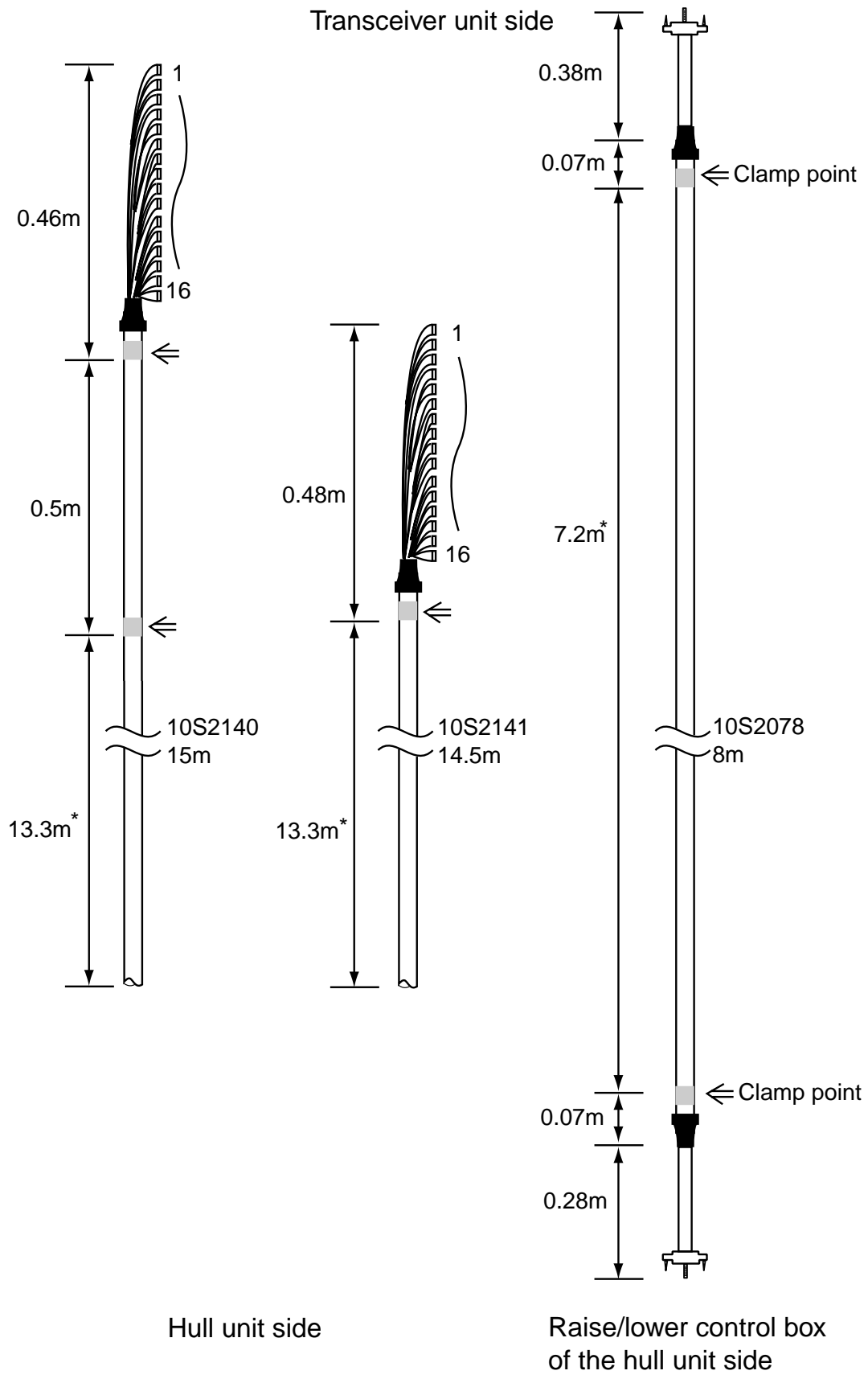

*: Cable length between the transceiver and hull unit.

2.3 Monitor Unit

2.3.1 Fabrication of monitor cable 10S2074 (10 m)/10S2075 (30 m)



10S2074, sectional view

Fabrication of connector 00-8016-038-313761HV (CN-A303)

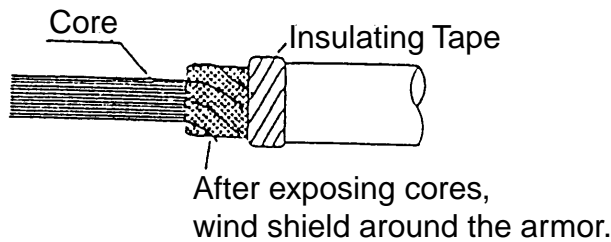
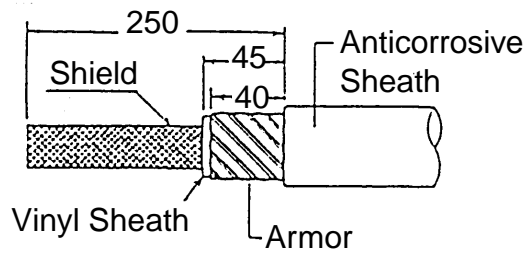

Fabrication of connector 00-8016-038-313761HV

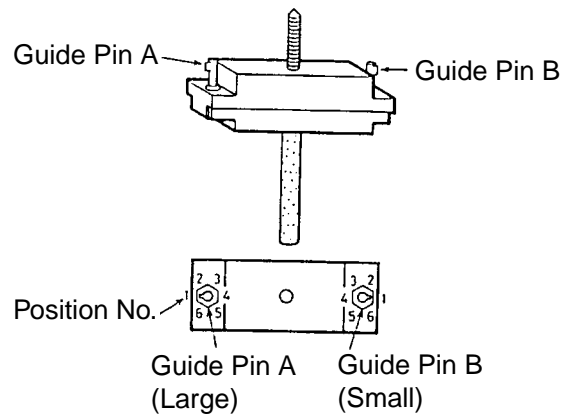
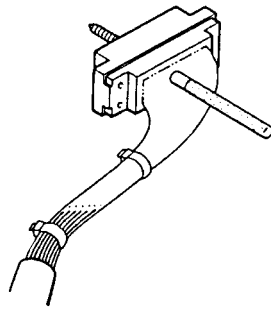

Assembling 38P connector

Positioning guide pins

Guide pins of the connector identify the mating receptacle.

They are;

- Guide pin A (Large): 4
- Guide pin B (Small): 1

Assembling BNC connector (CN-A304 to 308)

1. Remove vinyl sheath of the cable by 7.5 mm.
2. Pass the cable through the nut, washer, gasket and clamp.
3. Unravel the shield and fold it back onto the clamp.
4. Remove the insulator, leaving 3 mm.
5. Trim the shield as shown in the drawing. Solder the center chip to the conductor of the cable.
6. Pass the cable through the housing and tighten the nut.

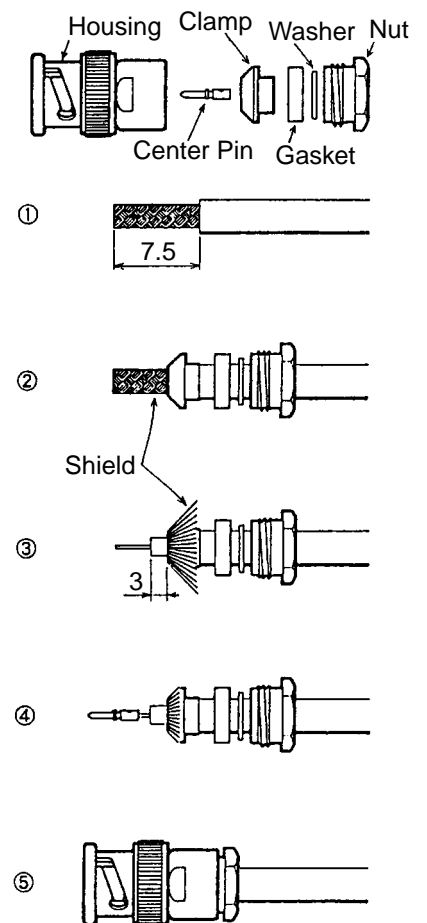

Assembling D-SUB connector (CN-A302)

1. Remove vinyl sheath of cores by 3 mm.
2. Pass the cores through shrink tubes (local supply).
3. Solder cores to connector pins referring to the schematic diagram at the back of this manual.
4. Assemble the connector.

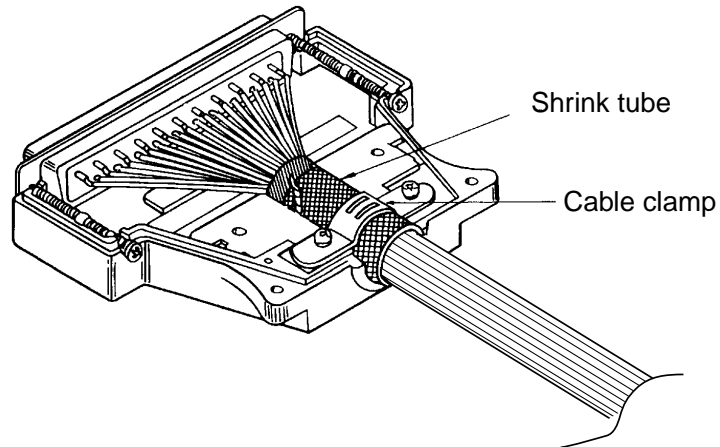

Assembling D-sub connector

2.3.2 Control cable

For FURUNO-supplied monitor, attach the cable from the control unit to the CN-A301 connector on the monitor unit as shown in the next section. For blackbox type, this cable should be connected to the CN-A103 connector in the processor unit.

2.3.3 How to connect cables to the monitor unit

Connect the monitor cable and control cable to the monitor (FURUNO-supplied monitor) unit as below.

1. Unfasten four screws (M4x10) at the rear of the monitor to loosen the cable cover.
2. Lift and pull the cable cover to remove it.
3. Unfasten two screws (M4x10) to remove the clamp cover.
4. Lay the monitor and control cables on the clamp, and then reattach the clamp plate to fix cables.
5. Connect eight connectors referring to the instruction sticker by the connector board.
6. Reattach the cable cover.

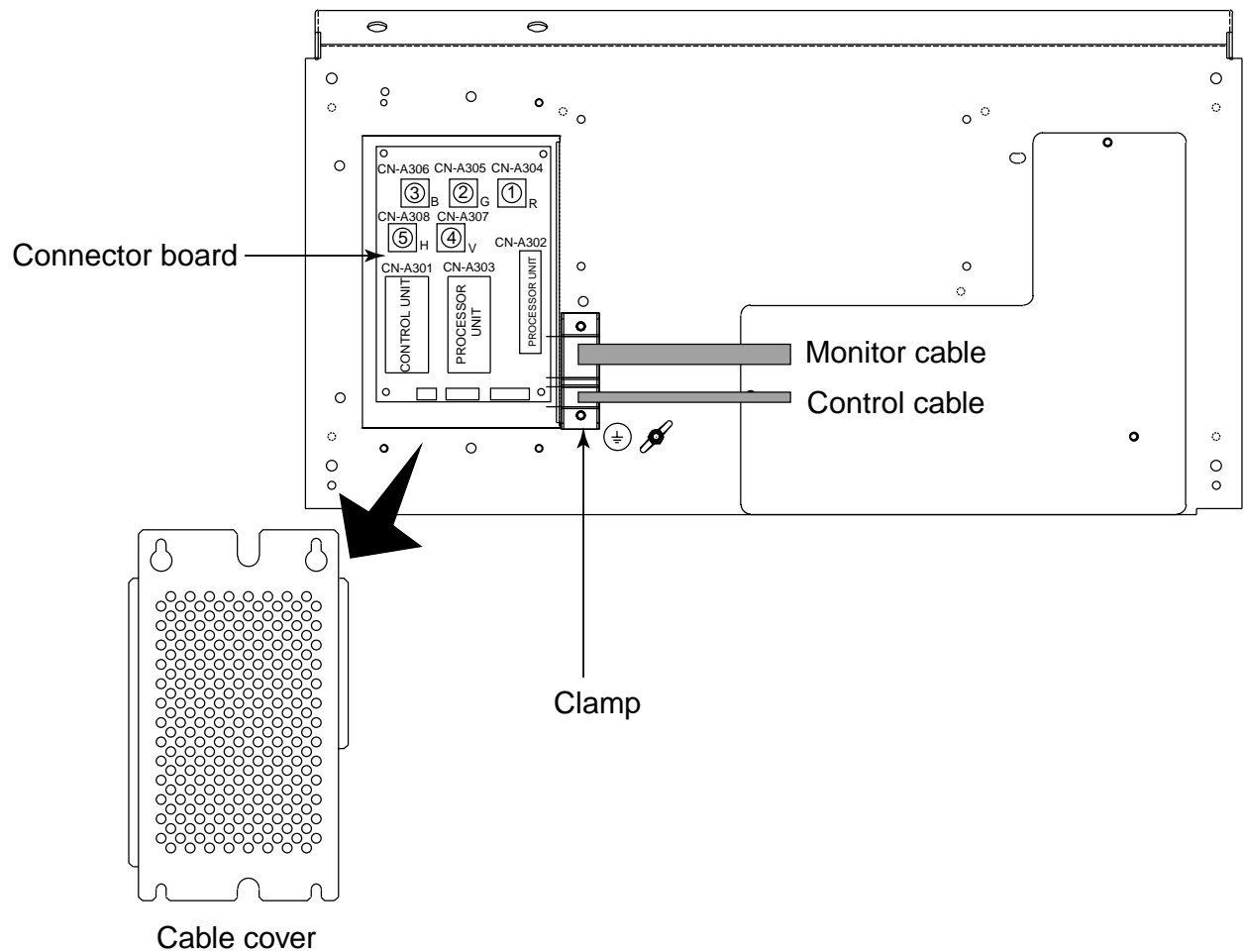

Monitor unit, rear view

2.4 Processor Unit

Cables (10S2074, 10S1258-1 and control cable) from the various units are connected to the CONE Board (10P6905) via the cable clamp (See page 2-2).

⚠ CAUTION

Divide cables attached to the back of the processor unit between right and left side. And then tie each group with a cable tie at the position 150 mm from connectors.

This is necessary to prevent cable stress.

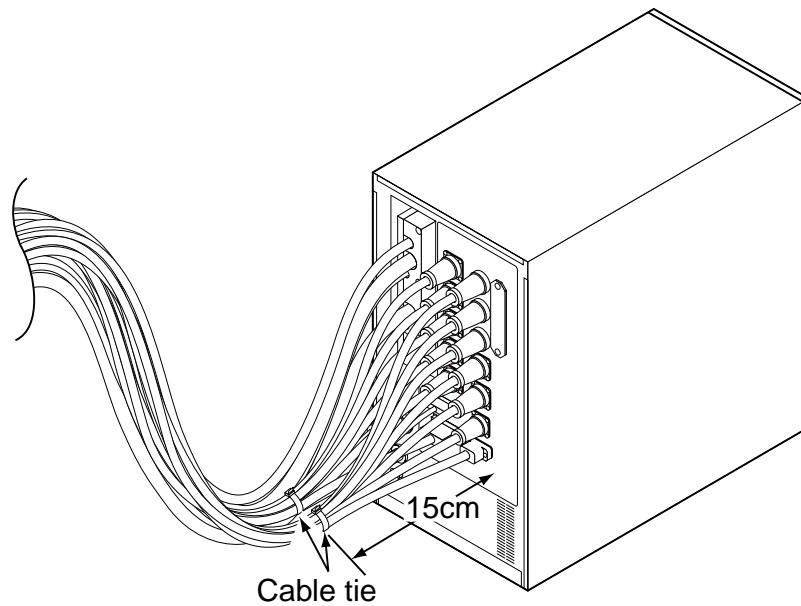

2.4.1 10S1258-1 cable

This cable runs between the processor unit and transceiver unit.



- 1: Coaxial cable
2 to 19: Twisted pair cable

Cable type 10S1258-1, sectional view

Fabrication of connector 00-8016-038-313761HV (CN-A101)

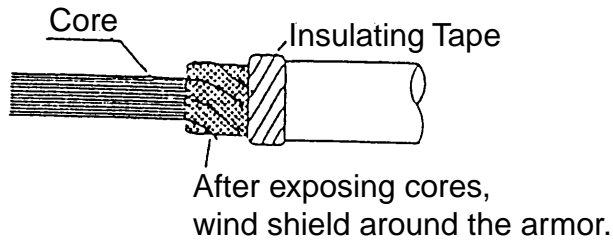
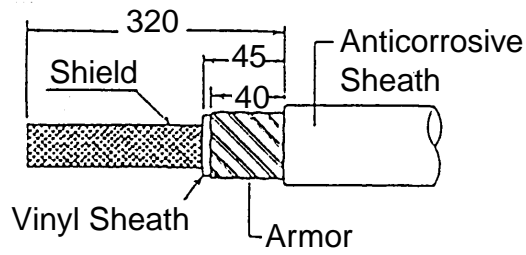

Fabrication of connector 00-8016-038-313761HV

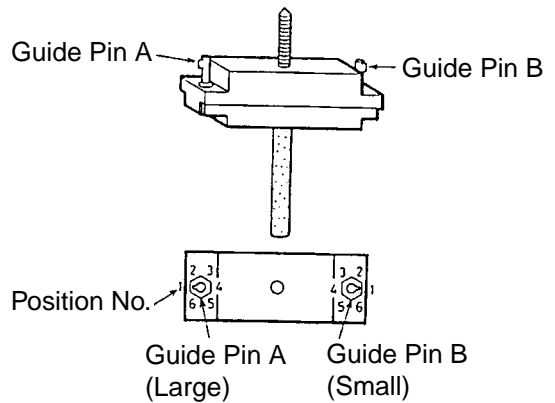
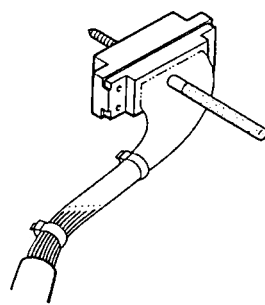

Assembling 38P connector

Positioning guide pins

Guide pins of the connector identify the mating receptacle. They are;

- Guide pin A (Large): 1
- Guide pin B (Small): 1

2.4.2 Power cable

Attach the NCS-253-P connector (CN-A110) to the power cable DPYCY-1.5 (Japan Industrial Standard (JIS) cable) or the equivalent for connection the ship's mains.

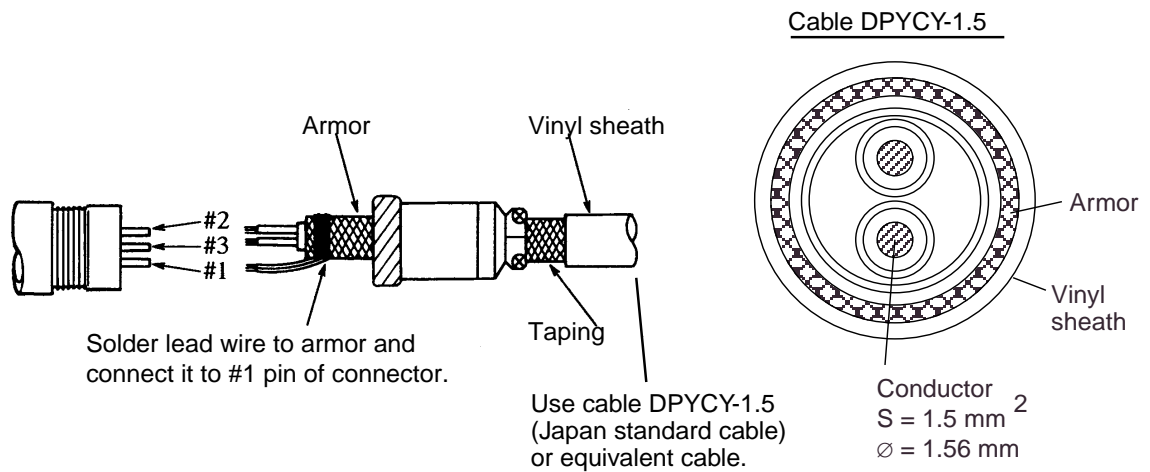

Assembling connector NCS-253-P

2.4.3 Monitor cable (10S2074 or 10S2075)

Connect the monitor cable 10S2074 or 10S2075 (from the monitor unit) to the connectors in the processor unit shown below.

- | | |
|----------------|---|
| 38P connector: | CN-A103 (For the optional sub-display, CN-A108) |
| D-sub 25 pin: | CN-A102 (For the optional sub-display, CN-A107) |
| D-sub 15 pin: | CN-A104 (For the optional sub-display, CN-A109) |

2.4.4 Control cable

For blackbox type, attach the control cable (10S2076) to the CN-A103 connector in the processor unit. The control unit for the sub-display unit should be connected to the CN-A108 connector.

2.4.5 Optional equipment

With connection of navigator and electronic fishing equipment, the function of the FSV-24 is expanded to include true motion presentation, target lock, echo sounder picture, FNZ marker presentation and digital indication of position, water temperature and depth.

Use the SRCN connectors (optionally supplied, Type: CP10-4801, Code no.: 006-934-240) to connect equipment to the rear of the processor unit referring to the interconnection diagram at the back of this manual.

Cable list

Outline of core	
○	Simple
◎	w/shield
∞	Twisted

Schematic view of cables

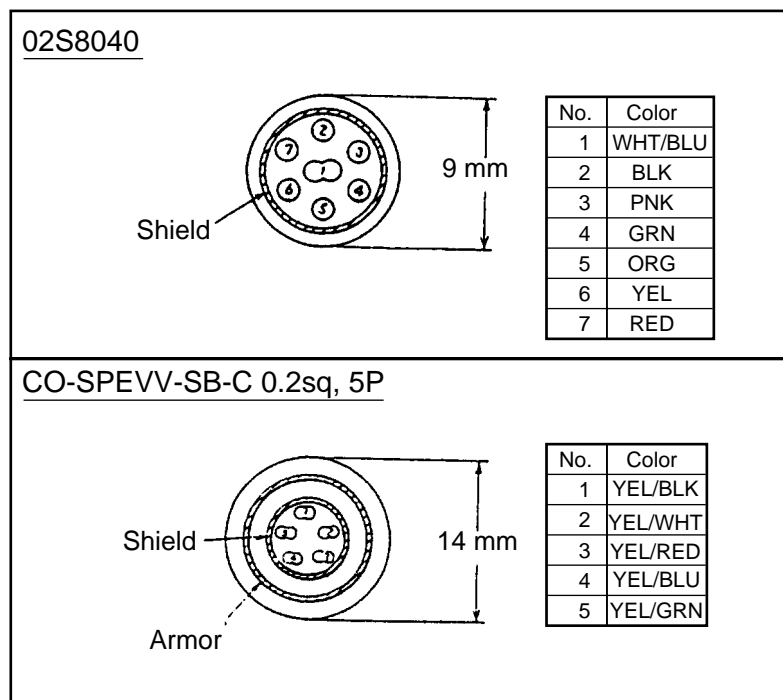

Cable with armor	J5 (CIF1)	: SRCN6A13-5P
	J7 (GYRO)	: SRCN6A16-10P
	J8 (LOG)	: SRCN6A13-3P
	J10 (FNZ)	: SRCN6A21-10P
	J13 (EXT-KP)	: SRCN6A21-10S

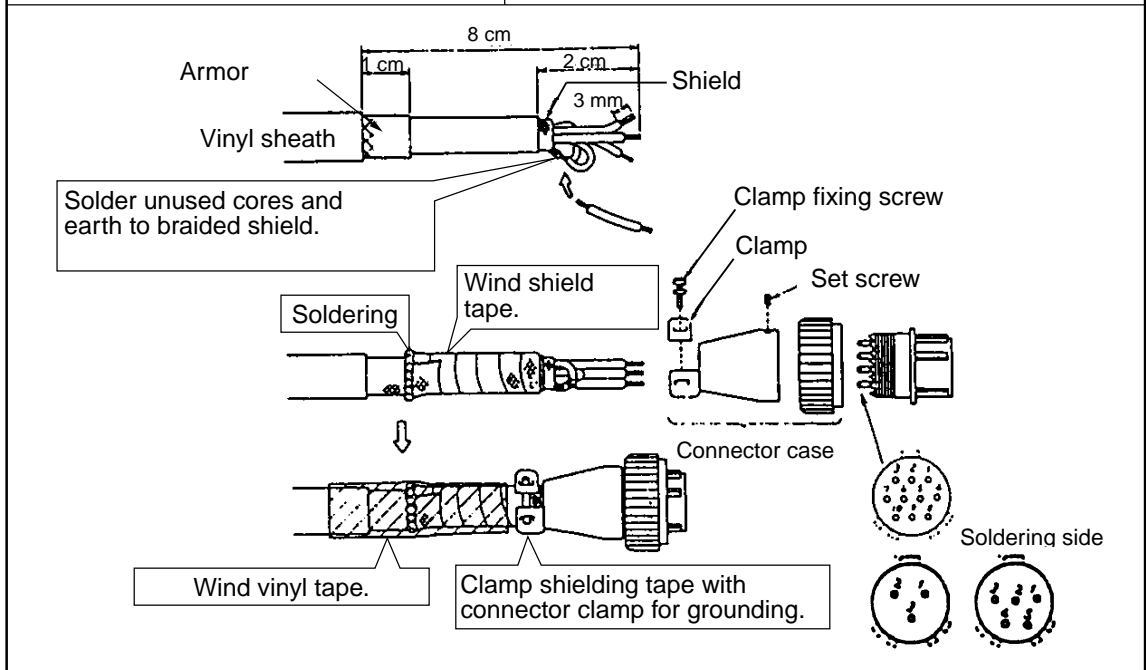

Cable without armor	J9 (ES1)	: SRCN6A16-7P
	J12 (ES2/NET)	: SRCN6A16-10P

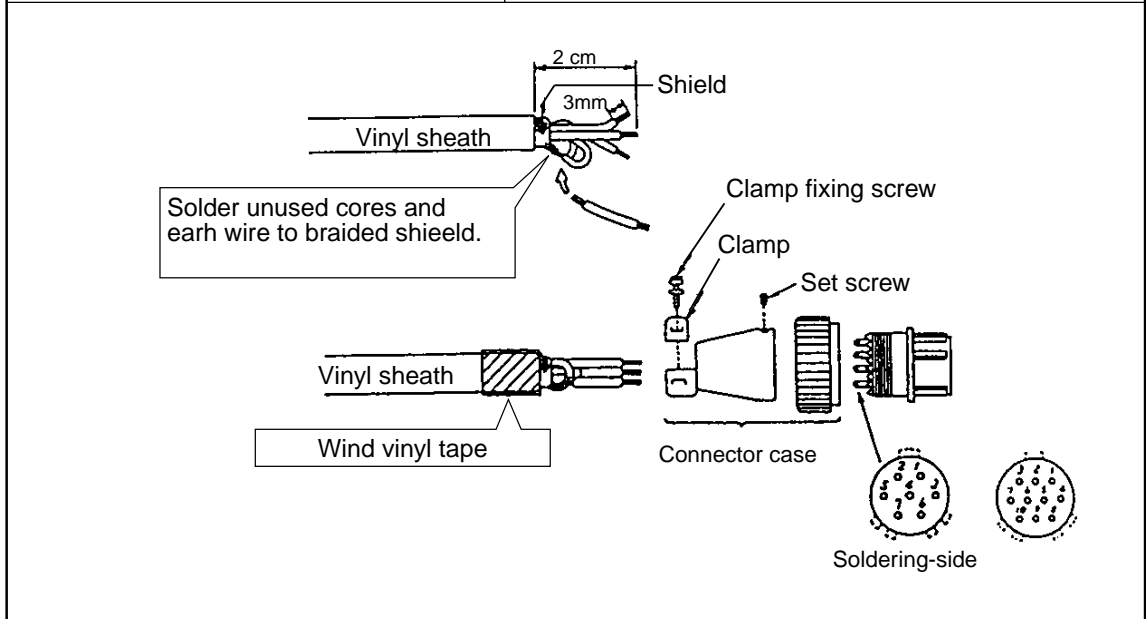

Synchronizing with echo sounder or other sonar

To synchronize the transmission of the FSV-24 with an echo sounder or other type of sonar, make connections as shown below.

For current driven KP input

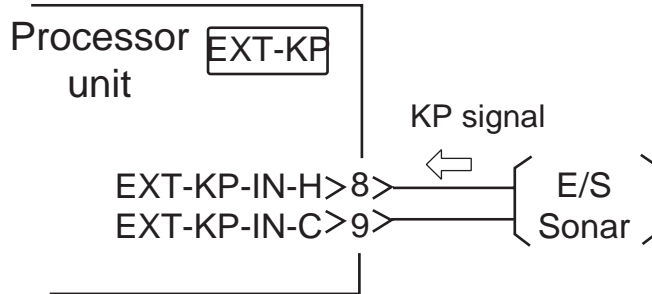

For voltage driven KP (12 V) input

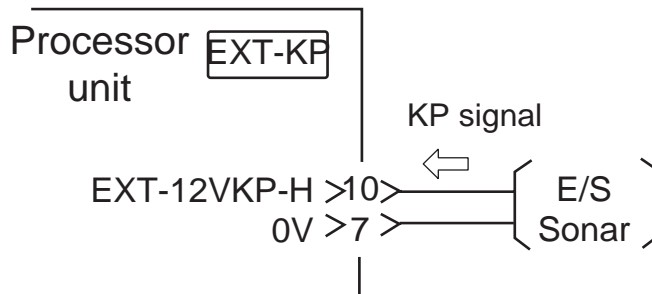

Voltage driven KP output

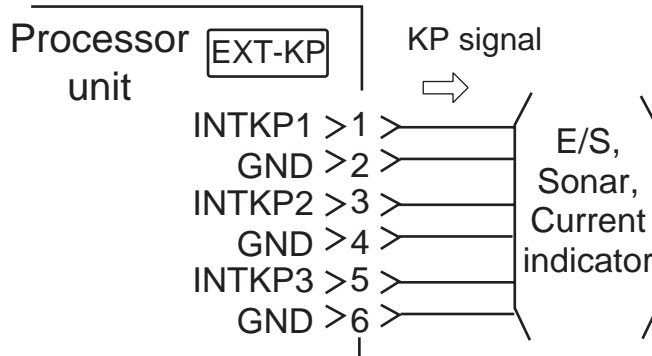

Menu setting

See EXT KP INPUT on page 3-8.

2.5 Transceiver Unit

2.5.1 Fabrication of connector 00-8016-038-313761HV (CN-B101)

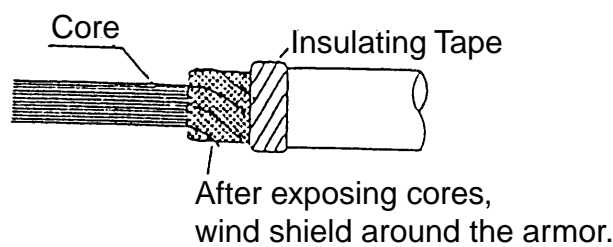
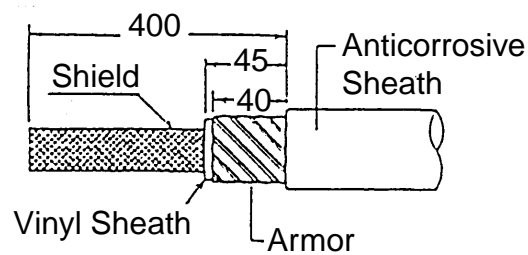

Fabrication of connector 00-8016-038-313761HV

Shorten the unused wires appropriately and treat their ends with vinyl tape to prevent short circuit.

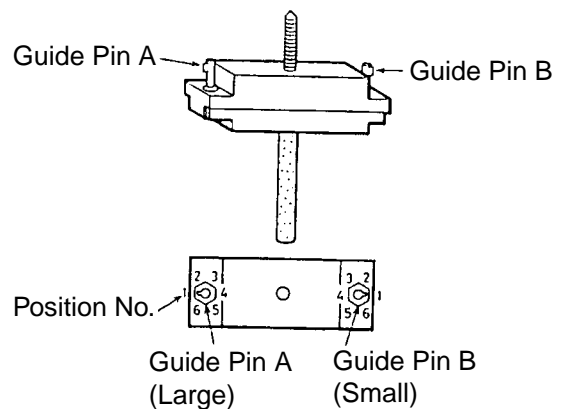
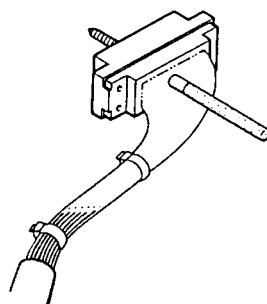

Assembling 38P connector

Positioning guide pins

Guide pins of the connector identify the mating receptacle. They are;

- Guide pin A (Large): 1
- Guide pin B (Small): 1

2.5.2 Fabrication of power cable type DPYCY-4 (TB-B101)

Fabricate the cable DPYCY-4 as below for connection to the power unit.

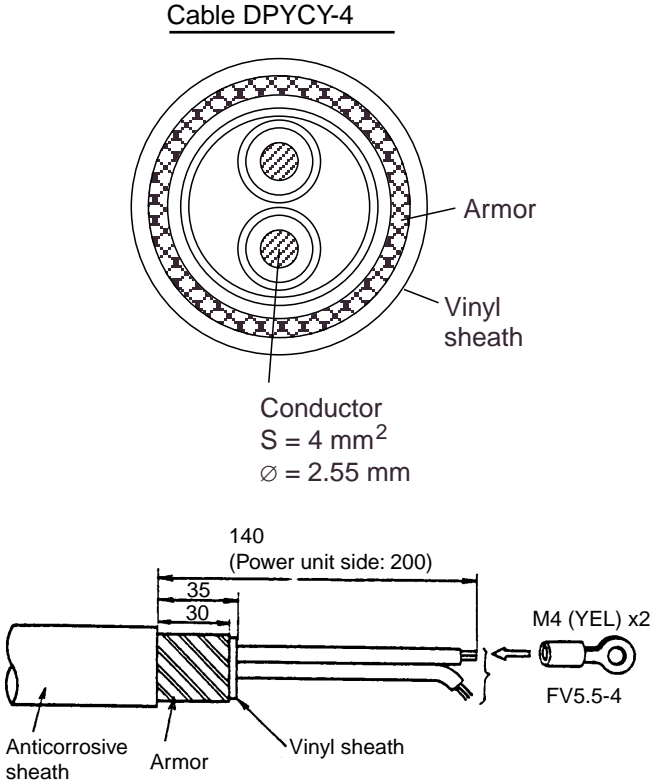

Fabrication of cable type DPYCY-4

2.5.3 Hull control cable (10S2078)

Connect the hull control cable (10S2078) to the CN-B102.

Note: The same type of connector is fitted at each end, however the connector where the amount of sheath removed is greater should be connected to the transceiver unit.

2.5.4 Connection

1. Open the transceiver unit cover.
2. Plug the XH connectors at the end of signal cables (10S2140, 10S2141) into the proper receptacles in the transceiver unit, referring to the labels on the cables and numbers on the TRX board.
3. Lead the cables into the transceiver unit appropriately. For clamping, lay the cables as shown in the figure "Cable location at metal clamp, top view" below.
4. Unfasten the cable fixing strip after wiring the hull unit.

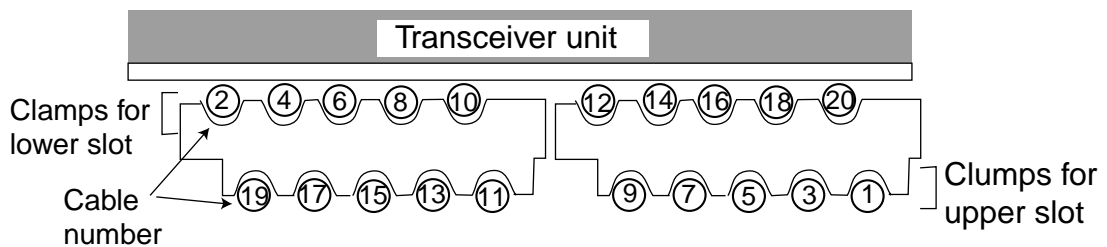
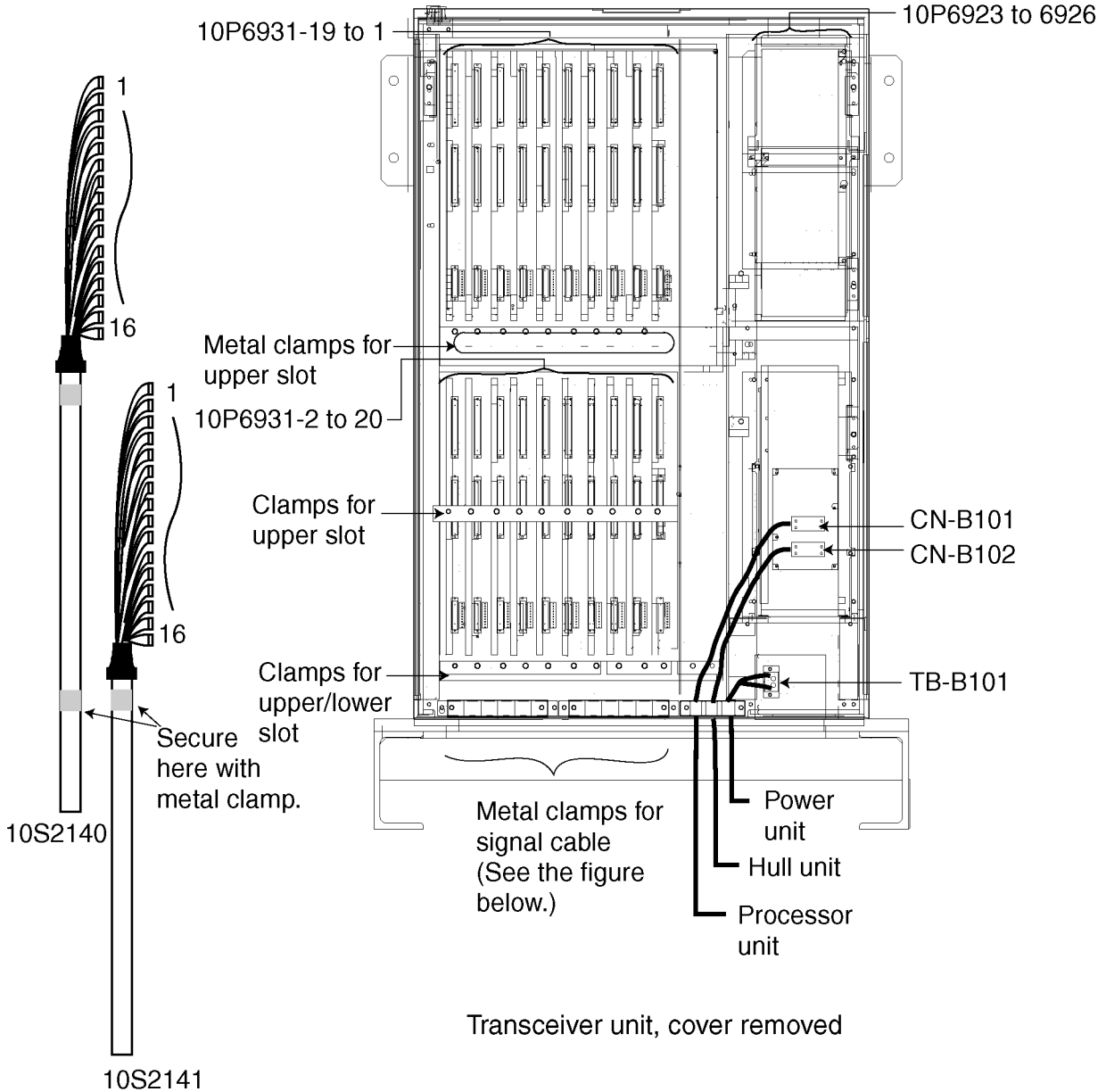

Cable location at metal clamp, top view

2.6 Power Supply Unit

Connect the power cable DPYCY-4 or equivalent as below.

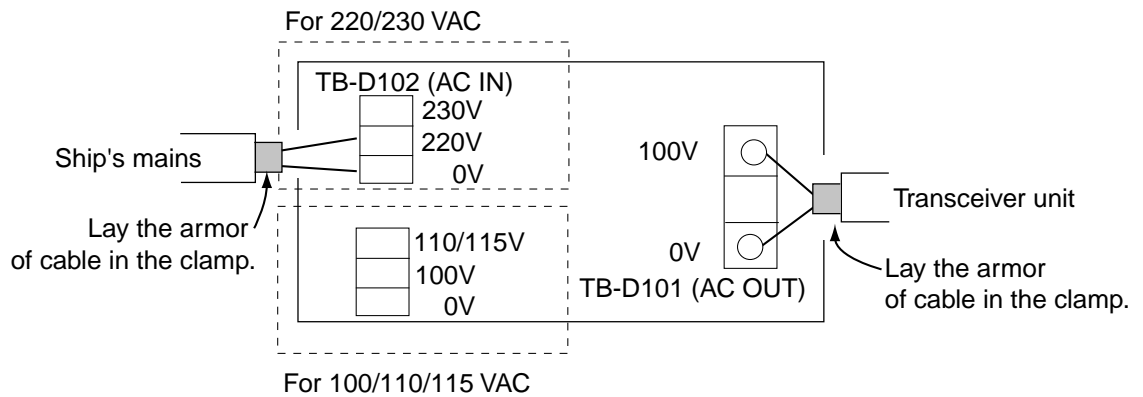

Power unit connection

2.7 Cable for Extension Kit

The standard length of the cable between the hull unit and transceiver unit is 5 meters. If a longer cable is required use the extension kit. This kit provides a junction box and a 5 meters cable or 15 meters cable.

2.7.1 Junction box

Connect the 10S2138 and 10S2139 of extension cables and transducer cables to the MTC1 and MTC2 in the junction box included with the cable extension kit, matching cable number with board location number.

1. Open the junction box cover.
2. Unfasten the metal clamp and fixing plates from the junction box.

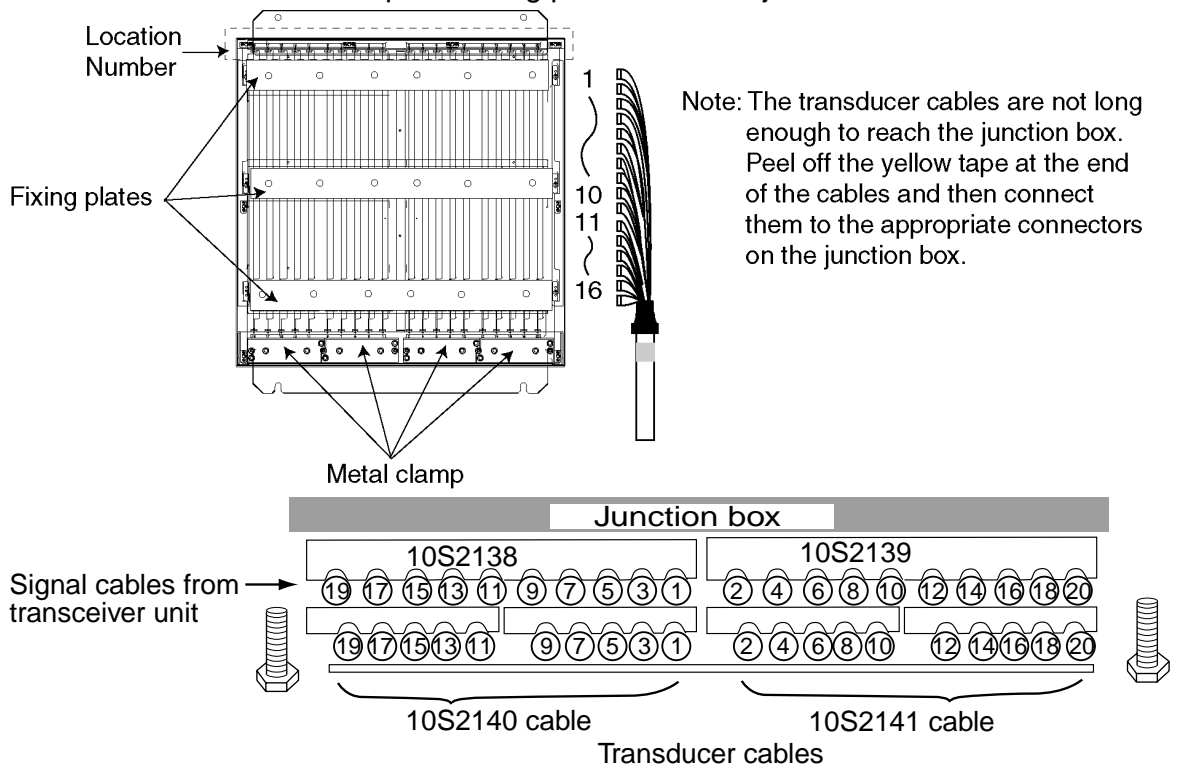

Junction box, cover removed

- Starting from the right side of the junction box, fix the cables by CSK clamp, pass them through cable clamps and connect XH connectors to the MTC board.

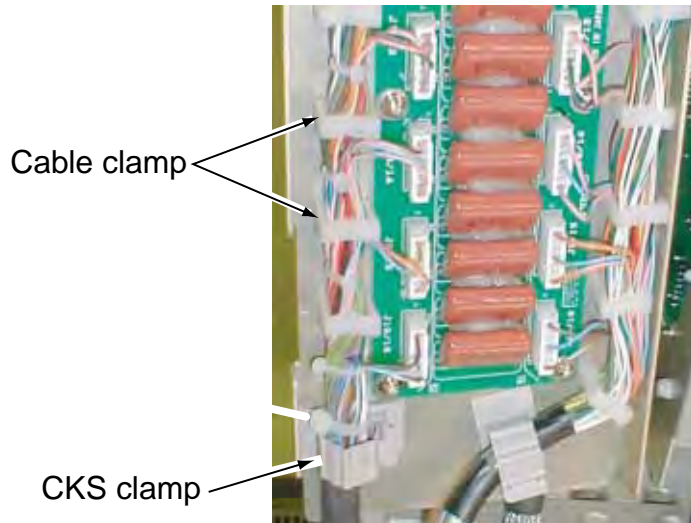

Note: Capacitors not present on latest version of MTC board.

Junction box, cover removed, front view



Note: Capacitors not present on latest version of MTC board.

Transducer cable
(10S2140/10S2141)

Signal cables from
transceiver unit
(10S2138/10S2139)

Junction box, cover removed, front view

- Fasten the shield part of the cable with metal clamp.
- Fasten the fixing plates.

2.7.2 Raise/Lower Control Box

Connect power cable (3 ϕ) and the transceiver unit cable (10S2078) as shown below.

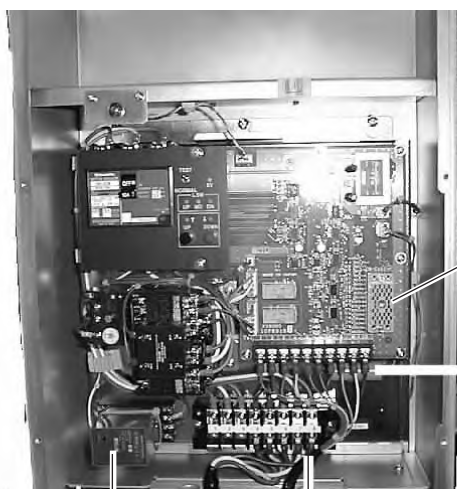

CN-C101
Connect the transceiver cable (10S2078) to here.

TB-C101
Connect the power cable TPYCY-4 (Japan Industrial Standard) or the equivalent to this board.

LED (Red)
For detection of phase reversal on 3 phase power cable

Cable TPYCY-4

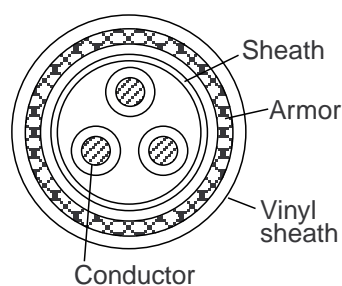

$S = 4 \text{ mm}^2$
 $\varnothing = 2.55 \text{ mm}$

Confirm LED after completing the installation. The LED lights (in red) if power connection is correct. If it is off, turn off power from the mains switchboard, check the cable connection and recheck the LED. The hull unit does not work if this connection is wrong.

Normal phase: LED lights (in red).

Phase reversal: LED does not light.

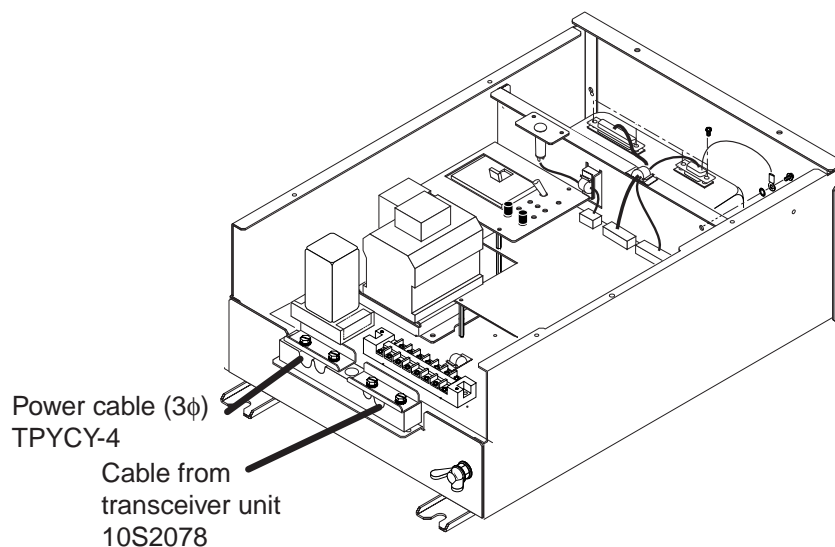

Raise/lower control box, cover removed

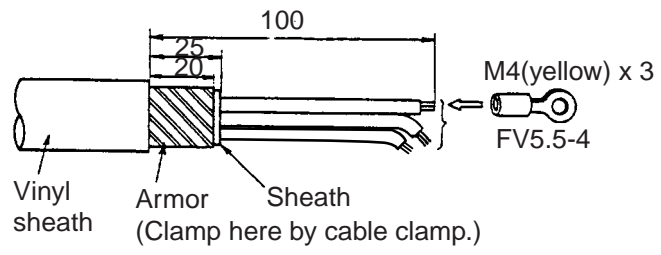

Power cable fabrication

3. ADJUSTMENT AND CHECK

3.1 Hull Unit Check

Note: Before conducting this check (at the dry dock) transmission must be stopped.

Default setting of TX transmission is OFF. Confirm as follows.

1. Turn on the power, and then press the [MENU] key to show the main menu.

MENU	QUIT
TX PULSE LENGTH-H :9	
TX POWER-H :9	
TVG-NEAR-H :0	
TVG-MEDIUM-H :0	
TVG-FAR-H :0	
AGC-H :0	
2ND AGC-H :0	
ECHO AVERAGE-H :0	
COLOR-H :COLOR 1	
COLOR RESPONSE-H :COLOR CURVE 3	
<hr/>	
H-SCAN SETTING...	
V-SCAN SETTING...	
OTHERS...	

Main menu

2. Use the trackball to select OTHERS and press the [MENU] key.

MENU	QUIT
OTHERS	QUIT
<hr/>	
ES1 SETTING...	
ES2 SETTING...	
ERASE MARKS...	
DISPLAY SETTING...	
FISH ALARM & AUDIO...	
PRESET, MEMORY CARD...	
INITIAL SETTING...	

OTHERS menu

3. Select INITIAL SETTING and press the [MENU] key.

— CAUTION — THIS ITEM IS DEFINED AS NON- CHANGEABLE ITEM, ARE YOU SURE TO CHANGE IT TO CHANGEABLE ?	YES
	NO

4. Select YES and press the [MENU] key.

MENU	QUIT
OTHERS	QUIT
INITIAL SETTING	QUIT
MARK DISPLAY... MARK SIZE... DATA DISPLAY... CURRENT VEC & WIND... NET SONDE SETTING... NET SHOOT SETTING... TARGET LOCK... STABILIZATION... TEST... INITIALIZATION...	

INITIAL SETTING menu

5. Select TEST and press the [MENU] key.

MENU	QUIT
OTHERS	QUIT
INITIAL SETTING	QUIT
TEST	QUIT
BOARD TEST... PANEL TEST... TEST PATTERN... RX TEST... NOISE TEST... TX : ON	

TEST MENU

6. Select TX and press the [MENU] key.
7. Select OFF and press the [MENU] key.
8. Select QUIT at the top of the menu screen and press the [MENU] key.

How to check the hull unit

1. Press the POWER (I) switch on the control unit (for the display unit) to turn on the equipment. Confirm that the lamps above the ON and  switches light.

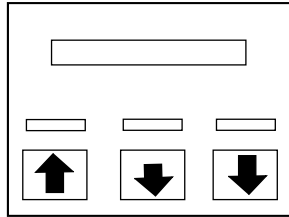

Transducer switches

2. Confirm that the 5V and UP lamps on the raise/lower control box are lit.
3. Remove the cover of the raise/lower control box and use a multimeter to measure the following voltages:



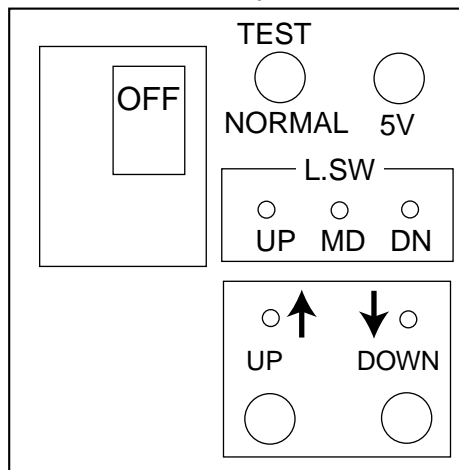

Terminal	Terminal No.	Voltage
TB-C101	(1) – (2), (6) –(7)	220 VAC
	(2) – (3), (7) – (8)	220 VAC
	(1) – (3), (6) –(8)	220 VAC

4. In the raise/lower control box, set the TEST/NORMAL switch to TEST. Press the [DOWN] switch to confirm that the transducer lowers. Also, while the transducer is being lowered, check that the MD LED lights when the MD L. SW kicks. Note that the MD L. SW does not stop the transducer when the TEST/NORMAL switch is in the TEST position.



Control unit (for the hull unit)

5. Press and release [DOWN] switch. Confirm that the transducer stops at the moment the switch is released.
6. Press the [DOWN] switch again. Confirm that the transducer stops at the moment the lower limit switch kick.
7. Confirm that the [UP] switch operators in a similar manner.

8. Check that LEDs on the panel of the raise/lower control box light as follows:
 - a) UP, MD and DN LEDs light when corresponding limit switch is kicked.
 - b) UP and DOWN LEDs light while UP and DOWN switches are pressed and extinguish when switches are released.
9. Set the TEST/NORMAL switch to NORMAL.
10. At the control unit for the display unit, press the  (mid position) switch. Confirm that the lamp above the switch blinks while the transducer is being lowered, a short beep sounds when the mid limit switch kicks, and the lamp lights when the transducer is fully lowered.
11. Press the  switch. Confirm that the lamp above the switch blinks while the transducer is being lowered, a short beep sounds when the mid limit switch is kicked, and the lamp lights when the transducer is fully lowered.
12. Press the  switch. Confirm that the lamp above the switch blinks while the transducer is being raised, a short beep sounds when the mid limit switch is kicked, and the lamp lights when the transducer is fully raised.
13. Press the OFF switch. Confirm that the transducer is completely retracted and then the power is turned off.
14. With the transducer lowered, confirm that the transducer is raised when  or OFF is pressed.

3.2 Heading Adjustment

When the BOW mark on the flange of the hull unit cannot be directed toward ship's bow adjust the heading so an echo which is dead ahead appears dead ahead on the display.

1. Referring to the previous section, set the TX (transmission) to ON.
2. Locate a target in the bow direction (buoy, for example) and display it on a near range. If the target appears at 12 o'clock the heading alignment is correct. If it does not, measure the error and go to step 2.

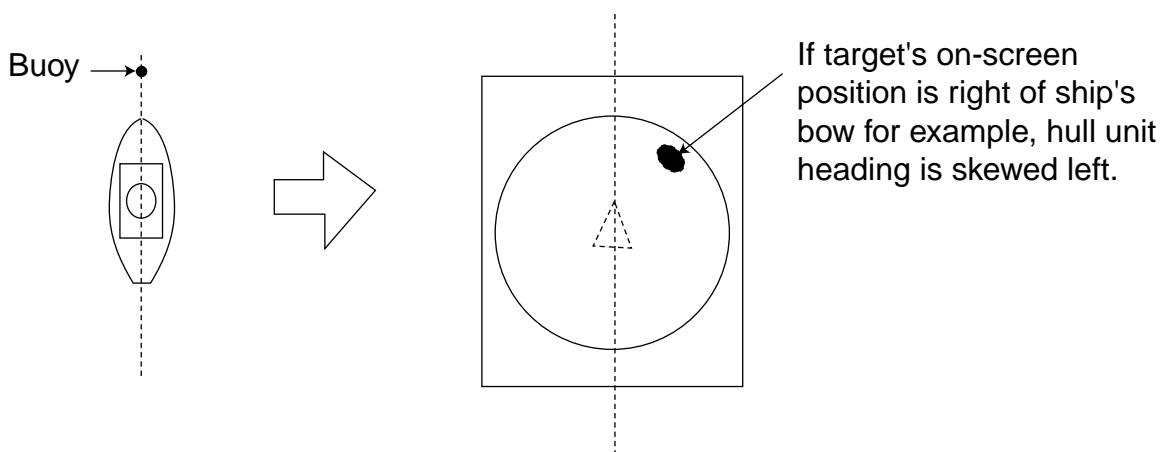

Heading adjustment

3. After turning off the power, turn it again on the power while pressing and holding down the [MENU] key. Release the figure from the [MENU] key after the self- test screen appears. And then after picture appears, press the [MENU] key three times to open the SYSTEM menu.

SYSTEM MENU	QUIT
INTERFACE SETTING..	
EXT DATA SETTING..	
OWN SHIP MARK..	
TEST&INITIALIZATION..	
TRX SETTING 1..	
TRX SETTING 2..	
OTHERS..	

SYSTEM menu

4. Use the trackball to select OTHERS and press the [MENU] key.
5. Select HEADING ADJUST and press the [MENU] key.

MENU	QUIT
OTHERS	QUIT
LANGUAGE	: ENGLISH
HEADING ADJUST	: 0°
ES2 SELECT	: ES
ES DRAFT OFFSET	: 0.0 m
EVENT KEY	: EVENT
AUTO TILT	: WIDE
SELECT USER PROG	: H/V INTERLOCK
TRACKBALL SPEED	: NORMAL
HULL UNIT STROKE	: 1200mm

QUIT
CANCEL
▲
▼

OTHERS menu, HEADING ADJUST

6. Select ▲ or ▼ and press the [MENU] key to adjust the heading. Each pressing of the [MENU] key changes the setting in 1° steps. The setting range is -180° to 179°.
7. Select QUIT to finish the adjustment and press the [MENU] key.
8. Select QUIT at the top of the menu screen and press the [MENU] key to close all menus.

3.3 Configuring Own Ship Mark

Set own ship's dimensions and the location of the transducer to accurately display the own ship mark on the display.

1. Press the [MENU] key to display the SYSTEM menu.

SYSTEM MENU	QUIT
INTERFACE SETTING..	
EXT DATA SETTING..	
OWN SHIP MARK..	
TEST&INITIALIZATION..	
TRX SETTING 1..	
TRX SETTING 2..	
OTHERS..	

System menu

2. Use the trackball to select OWN SHIP MARK and press the [MENU] key.

MENU	QUIT
OWN SHIP MARK	QUIT
SHIP'S LENGTH : 75m	
SHIP'S WIDTH : 20m	
TD POSITION 1 : 15m	
TD POSITION 2 : 0.0m	

OWN SHIP MARK menu

3. Use the trackball to select SHIP'S LENGTH.
4. Press the [MENU] key to show the setting window.

MENU	QUIT
OWN SHIP MARK	QUIT
SHIP'S LENGTH : 75m	
SHIP'S WIDTH : 20m	
TD POSITION 1 : 15m	
TD POSITION 2 : 0.0m	

QUIT
CANCEL
▲
▼

OWN SHIP MARK menu, setting window

5. Select ▲ or ▼ and then press the [MENU] key several times to set the ship's length (15 to 150 m).
6. Select QUIT to finish the setting.
7. Set the SHIP'S WIDTH (5 to 30 m), TD POSITION 1 (5 to 50 m) or TD POSITION 2 (-10.0 to 10.0 m) similarly.
 TD POSITION 1: Set the transducer's distance from the bow.
 TD POSITION 2: Set the transducer's distance from the keel. Select the [+] for starboard, [-] for port.
8. Select QUIT at the top of the menu screen and press the [MENU] key to close all menus.

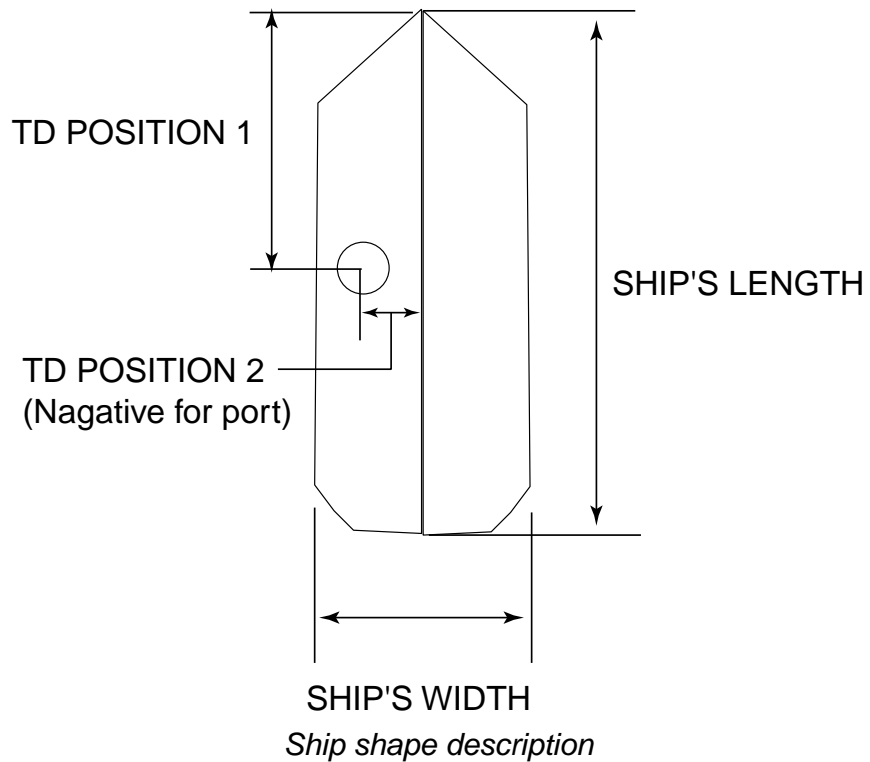

3.4 Other SYSTEM Menu Items

This section shows you how to set up external equipment. Default settings are underlined.

3.4.1 INTERFACE SETTING menu

MENU	QUIT
INTERFACE SETTING	QUIT
NMEA 1 BAUD RATE: 4800 bps	
NMEA 2 BAUD RATE: 4800 bps	
CIF BAUD RATE	: 4800 bps
AUX BAUD RATE	: 19200 bps
EXT KP INPUT	: DISABLE
EXT KP OUTPUT	: NEGATIVE

INTERFACE SETTING menu

NMEA 1 BAUD RATE

Set the transmission rate for the NMEA 1 port.
(2400 bps, 4800 bps, 9600 bps, 19200 bps)

NMEA 2 BAUD RATE

Set the transmission rate for the NMEA 2 port.
(2400 bps, 4800 bps, 9600 bps, 19200 bps)

CIF BAUD RATE

Set the transmission rate for the CIF port. (2400 bps, 4800 bps, 9600 bps, 19200 bps) If the CS-120A is connected, select "2400 bps".

AUX BAUD RATE

Set the transmission rate for the AUX port. (2400 bps, 4800 bps, 9600 bps, 19200 bps)

EXT KP INPUT

Select whether the KP signal from external equipment is used or not, and set the edge polarity. (DISABLE, POSITIVE, NEGATIVE)

Note: Set TX INTERVAL in H-SCAN SETTING menu to "0" for transmission with external kp signal.

EXT KP OUTPUT

Select the KP output logic, POSITIVE or NEGATIVE. (POSITIVE, NEGATIVE)

3.4.2 EXT DATA SETTING menu

MENU	QUIT
EXT DATA SETTING	QUIT
DATE&TIME	: CIF
HEADING	: AD10S
LOG PULSE	: 200p/NM
SPEED&COURSE	: NMEA
SPEED SENSOR	: GPS/DR
LAT/LON	: NMEA
POSITIONING SENSOR	: AUTO SEL.
WATER DEPTH	: NMEA
WATER TEMP.	: NMEA
WATER CURRENT	: CIF
WIND	: CIF

EXT DATA SETTING menu

DATE & TIME

Select input port of data and time data. (NONE, CIF, NMEA)

HEADING

Select input port of the heading data. (NONE, AD10S, CIF, NMEA)

LOG PULSE

Set the pulse rate per 1 nm for the distance pulse signal. (200 p/NM, 400 p/NM)

SPEED & COURSE

Select the input port for the ship's speed and course data input. When selecting the LOG&HEADING, the heading data is used instead of the course data. (NONE, LOG&HEADING, CIF, NMEA)

SPEED SENSOR

Select the source for the speed and course data. This setting is ineffective when LOG&HEADING is selected as speed and course source. (NONE, GPS/DR, DOPPLER/DR)

LAT/LON

Select the input port for the ship's position data. (NONE, CIF, NMEA)

POSITIONING SENSOR

Select the type of the navigator. When selecting AUTO SEL., the priority is GPS/DR>LORAN-C. (LORAN-C, GPS/DR, AUTO SEL.)

WATER DEPTH

Select the input port for the depth data. (NONE, CIF, NMEA)

WATER TEMP.

Select the input port for the water temperature data. (NONE, CIF, NMEA)

WATER CURRENT

Select the input port for the water current data. (NONE, CIF, NMEA)

WIND

Select the format for the wind data. (NONE, CIF, NMEA)

■ NMEA 0183 Data

Input

Position (L/L)	GGA, GLL, RMA, RMC
Heading	HCC, HCD, HDG, HDM, HDT
Course	VTG
Speed	VBW, VHW
Current	CUR, VDR
Depth	DBS, DBT, DPT
Temperature	MTW
Wind	MWV
Date Time	ZDA

Output

Position	TLL
----------	-----

3.4.3 OTHERS menu

MENU	QUIT
OTHERS	QUIT
LANGUAGE	: English
HEADING ADJUST	: 0°
ES2 SELECT	: ES
ES DRAFT OFFSET	: 0.0 m
EVENT KEY	: EVENT
AUTO TILT	: WIDE
SELECT USER PROG	: HVV INTERLOCK
TRACKBALL SPEED	: NORMAL
HULL UNIT STROKE	: 1200mm

OTHERS menu

LANGUAGE

Select the language. (JAPANESE, ENGLISH)

HEADING ADJUST

See “3.2 Heading Adjustment”.

ES2 SELECT

Select the equipment connected to the ES2 port among echosounder and net recorder. (ES, NET REC)

ES DRAFT OFFSET

When connecting echosounder, set the ship's draft line to use depth from draft rather than depth from transducer. (0.0 m to 10.0 m, 0.1 m steps)

EVENT KEY

Select the key for entering own ship's position, EVENT or SHOOT. When selecting SHOOT, the shoot function is not available. (EVENT, SHOOT)

AUTO TILT

Select the range for the auto tilt, WIDE (± 2 to 10° , ± 4 to 16° , ± 6 to 20°) or NARROW (± 1 to 4° , ± 2 to 6° , ± 3 to 8°). (WIDE, NARROW)

SELECT USER PROG

Select whether to program horizontal and vertical displays together or individually, by the USER PROG control. H/V INTERLOCK, the default setting, commonly applies control settings to the horizontal and vertical displays. H/V INDIVIDUAL enables individual adjustment.

TRACKBALL SPEED

Select the speed of trackball movement (inside menu window only). (SLOW, NORMAL, FAST)

HULL UNIT STROKE

Select the stroke length of the hull unit. (1200 mm, 1600 mm).

3.5 CONE Board Setting in the Processor Unit

Adjust the potentiometers on the CONE Board in the processor unit, referring to the table shown below.

Location No.	Name	Resistance value	Function	Adjustment
R118	ALARM	10 k Ω	Adjusting the volume of audio alarm.	CW: Large CCW: Small
R119	ES2_OFF	1 k Ω	Adjusting E/S2 signal offset.	CW: Noise decrease CCW: Noise increase
R167	ES_2GAIN	10 k Ω	Adjusting E/S2 signal gain.	CW: Gain increase CCW: Gain decrease
R168	ES1_OFF	1 k Ω	Adjust E/S1 signal offset.	CW: Noise decrease CCW: Noise increase
R209	ES1_GAIN	10 k Ω	Adjust E/S1 signal gain.	CW: Gain increase CCW: Gain decrease

3.5.1 Adjustment of signal level (echo sounder connected)

Adjusts the output level of the echo sounder on the CONE Board as below.

1. Select an echo sounder display (ES1 or ES2) from the menu.
2. For ES 1, adjust R168 to suppress noise, and then adjust R209 so that the picture condition is similar to that of connected echo sounder connected to the FSV-24.
3. For E/S 2, adjust R119 to suppress noise, and then adjust R167 so that the picture condition is similar to that of echo sounder connected to the FSV-24.

3.5.2 Adjusting the volume of audio alarm

The audio alarm volume cannot be adjusted from the control unit. If necessary, adjust R118 on the CONE Board to choose desired volume.

3.6 DIP Switch Setting

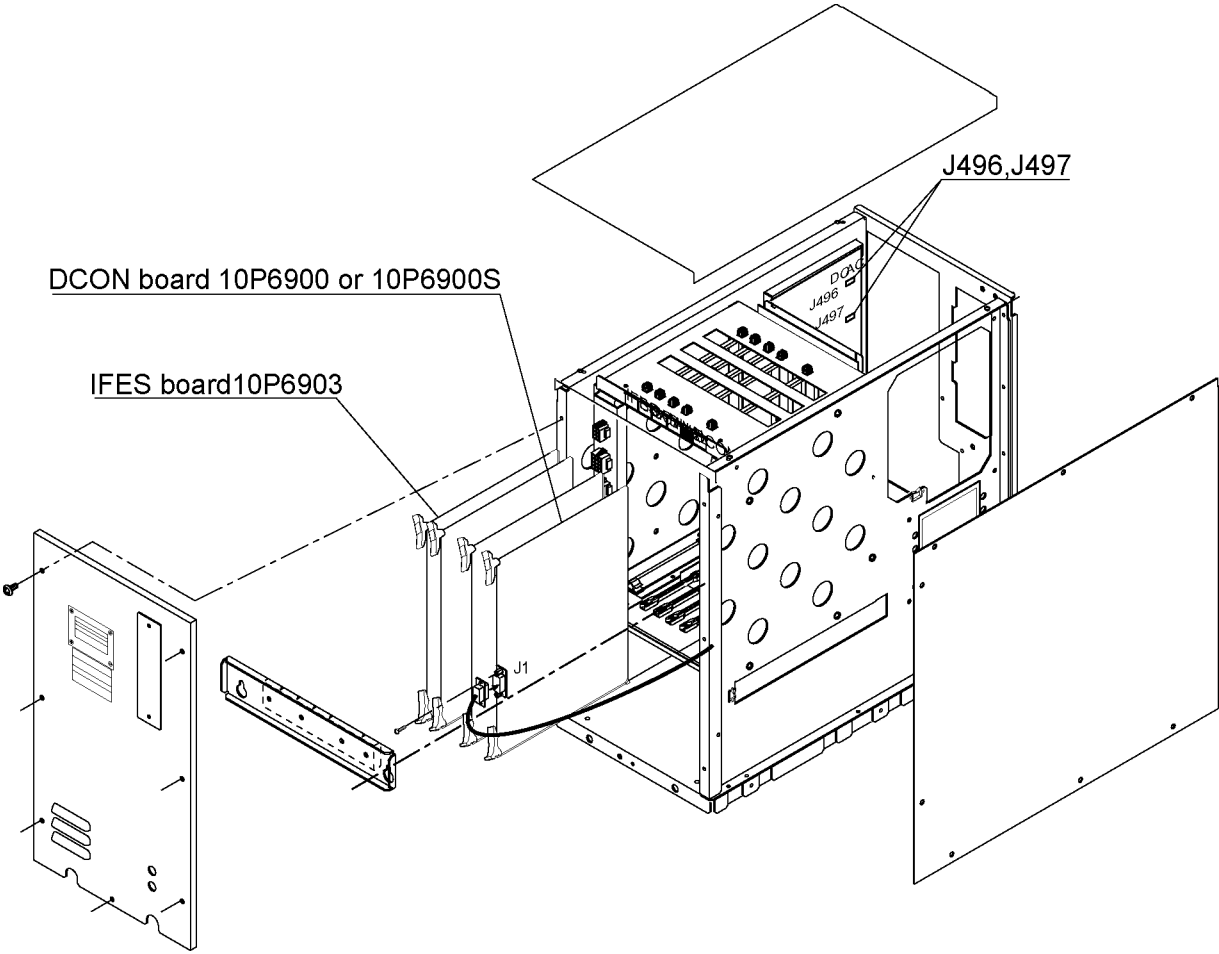

Processor unit, inside view

3.6.1 CIF2/NMEA2 connector interface selection

The signal format of the CIF2/NMEA2 port at the back of the processor unit can be set for CIF or NMEA by DIP switch S2-8 on the IFES Board (10P6903). The default format is OFF (CIF).

DIP switch setting	Format
S2-#8: ON	NMEA
S2-#8: OFF	CIF

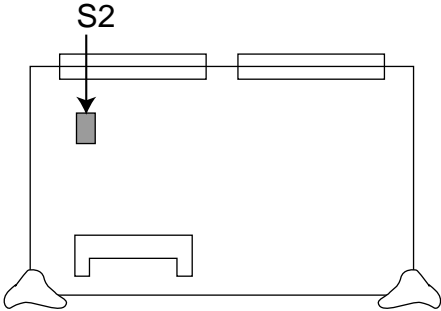

IFES Board (10P6903)

3.6.2 Selecting the Net Sonde information

The net depth information from the Net Sonde can be entered from the FNZ port or CIF port. Depending on the input port, select the DIP switch setting as follows. The default setting is FNZ.

Input port	DIP switch S3 - #1
FNZ(default)	OFF
CIF1 or NMEA2/CIF2	ON

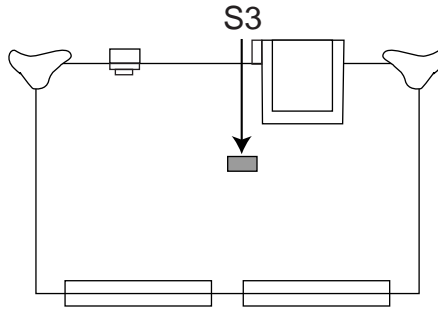

DCON Board (10P6900 or 10P6900S)

Note1: When the NMEA2/CIF2 port is used, the DIP switch S2-#8 on the IFES board should be OFF. See page 3-13.

Note2: Do not change the setting of S3-#4 (default: OFF). The hull unit may be damaged if the setting is changed.

3.6.3 Selecting echosounder signal

There are two kinds of echosounder signals, AC signal and DC signal. Depending on the signal, select the jumper setting at J496 and J497 on the CONE board as follows. The default setting is AC. See page 3-13 for parts location.

Input port	Jumper
ES1	J497
ES2/NET	J496

Note: SIGOUT (AC signal) terminal and REC terminal (DC signal) in the output port are provided for FURUNO echosounder. Therefore, when using SIGOUT terminal, it is not necessary to change jumper setting.

3.7 Testing TX/RX independently at hull unit

To check the Tx/Rx function of the hull unit independently, follow the steps below.

Note: This test should not be done at the dry dock. The transducer will be damaged.

1. Turn ON DIP switch S3#1 on the TRCPU Board (10P6926) in the transceiver unit.
2. Turn the TEST/NORMAL switch in the control unit of the hull unit to TEST.
3. Turn ON the maintenance switch in the transceiver unit.
4. Power on the transceiver unit, and then press the [DOWN] switch in the control unit for the hull unit to lower the transducer to the mid or fully lower position.
5. Confirm the MID or DN LED for the transducer position.
6. When the transducer reaches to mid or fully lower position, the transducer starts the transmission automatically with low power. Check the transmission channel.
7. Press the [UP] switch in the control unit for the hull unit to retract the transducer. Transmission stops.
8. Turn OFF the maintenance switch in the transceiver unit.
9. Turn the TEST/NORMAL switch in the control unit of hull unit to NORMAL.
10. Turn OFF DIP switch S3#1 on the TRCPU Board in the transceiver unit.

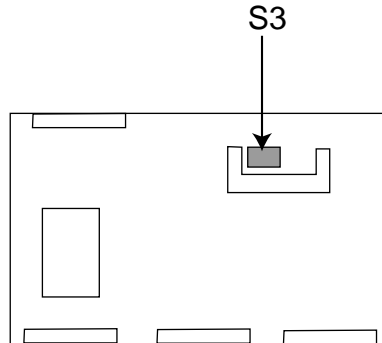

TRCPU Board (10P6926)

This page is intentionally left blank.

4. CONNECTING THE EXTERNAL INTERFACE CS-120A

When upgrading from the CSH-20 series sonar, the External Interface CS-120A can be used. Connect between the processor unit and the CS-120A as shown below. However, we recommend to connect external device to processor unit, instead of using the CS-120A, to avoid signal delay.

The following power supply kit (option) is required to install on the processor unit.

Name: Power Supply Kit Type: FSV-2403 Code No.: 000-067-013

Name	Type	Code No.	Q'ty	Remarks
Power supply pcb	LEA50F-24-XFND	000-143-913	1	
Spacer	SQ-22	000-159-305-10	4	
Protection sheet	10-071-3508	100-290-712	1	
Screw	M3x8 C2700W	000-163-190-10	4	
Connector (NJC)	NJC-203-PM	000-160-184-10	1	

1. Remove the front cover of the processor unit.

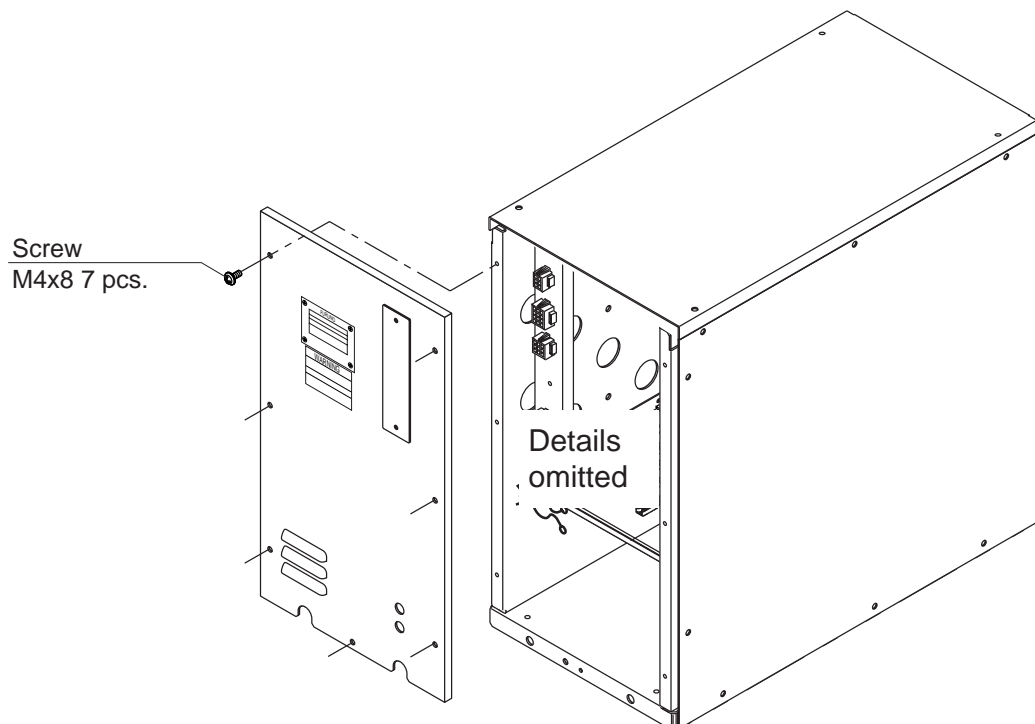

2. Remove two upset screws, detach the plugs J503, J502, J501, J504, J506 and J507, thus pull out the power block.

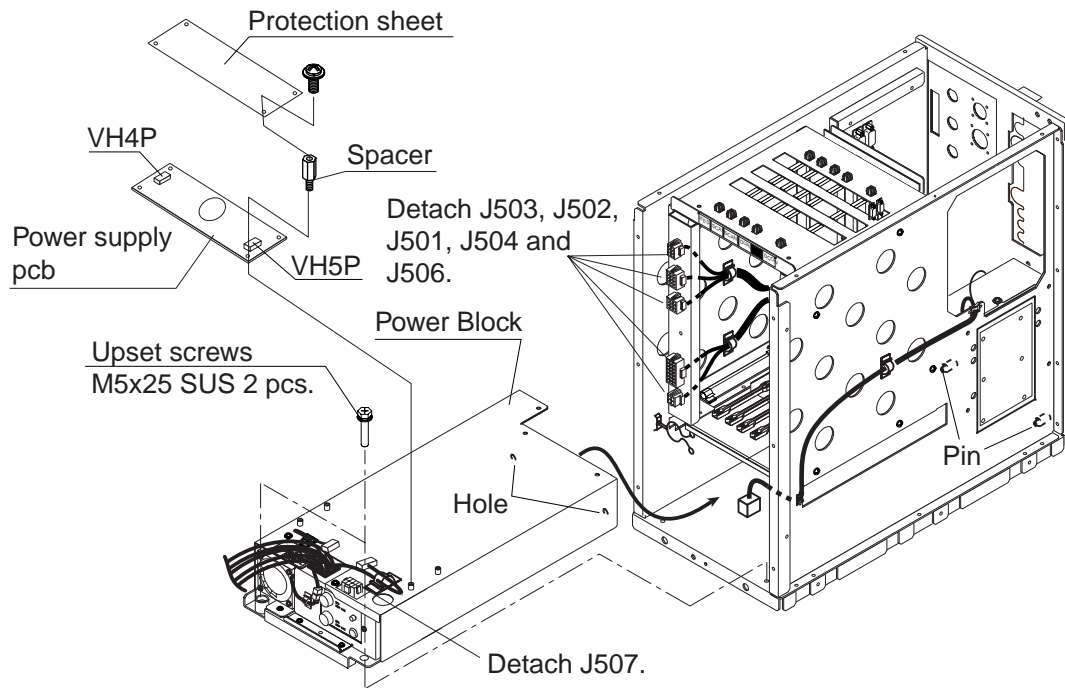

3. Fix the power supply pcb (supplied) to the power block with spacers (supplied).
4. Connect two VH connectors (provided on the power block) to the power supply pcb.
5. Put protection sheet (supplied) on the power supply pcb and fasten it with four screws.
6. Reattach the power block.

7. Connect between the processor unit and CS-120A as follows.

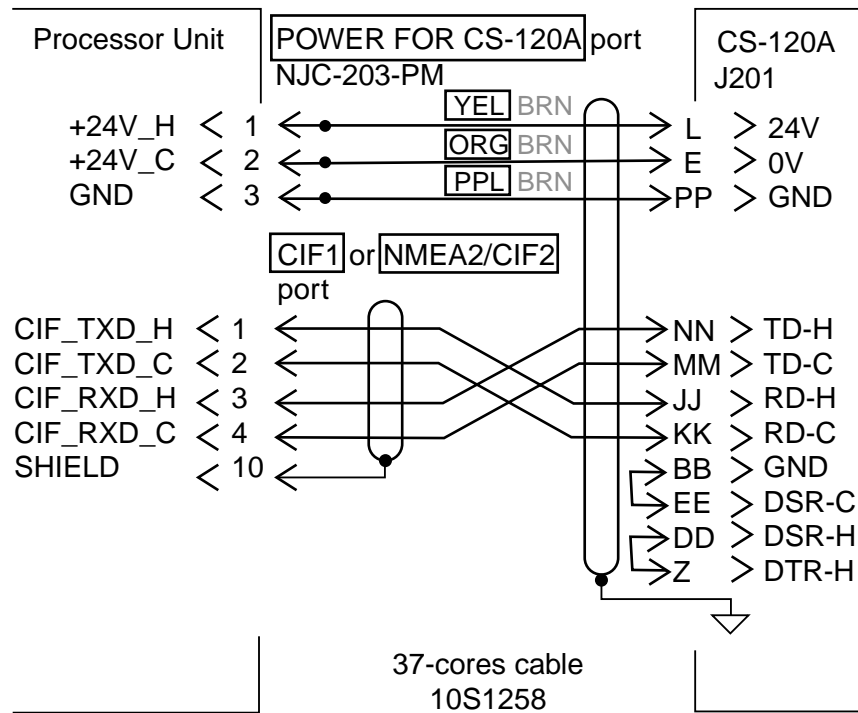

Note: Echosounder should be connected to the processor unit directly.

8. Set the DIP switch as follows.

Input port	DIP switch setting
CIF1	S3-#2: ON
NMEA 2/CIF 2	S3-#3: ON

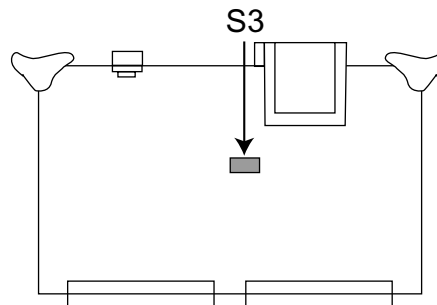

DCON Board (10P6900 or 10P6900S)

Note: Do not change the setting of S3-#4 (default: OFF). The hull unit may be damaged if the setting is changed.

Note: If the CIF is select, baud rate should be changed to 2400 bps. See page 3-9 for detail.

Check List Ship Name _____ Date / / Location _____

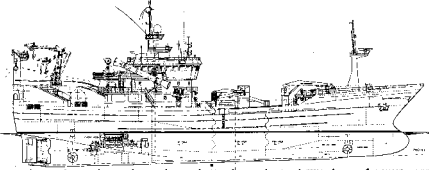
SCANNING SONAR	TYPE	FSV-24	RESULT	
S/N	Monitor unit (FSV-2400)	Options		
	Control unit (FSV-2401)	CS-120A		
	Processor unit (FSV-2402)	VI-1100A		
	Transceiver unit (FSV-241E)	CS-170		
	Power supply unit (FSV-242)	FSV-2451(5m),FSV2452(15m)		
	Hull unit (FSV-243E/244E)			
Reference				
Frequency	24KHz			
Transducer location				
				
Note:				
NO	CHECK ITEMS	CONTENT	RESULT	DATA
1	Unit installation	All units are installed according to installation manual.	Good/No Good	
2	Grounding	Copper plate should be connected for the following units. 1.Power supply unit 2.Transceiver unit 3.Junction box(Optional) IV-8sq is connected for the following units. 1.Raise/lower box 2.Processor unit 3.Monitor unit	Good/No Good	Sheet 1
3	Connection	Check the connection between each unit. 1.Transducer-Transceiver unit 2.Transceiver unit-Processor unit 3.Processor unit-Monitor unit 4.Monitor unit-Control unit 5.Processor unit- Other equipments 6.Ship's mains-Power supply unit 7.Ship's mains-Hull unit 8.Ship's mains-Processor unit	Good/No Good	Sheet 1
4	Power Supply (Ship's mains)	Check ship's mains voltage for following units. 1.Power supply unit 2.Raise/lower motor line Check whether led of phase detector is light or not. The 3 phase line must be changed if led is light. 3.Processor unit	Good/No Good	Sheet 1
5	Output power	Check output power and +B voltage.	Good/No Good	Fig1
6	Test	Check the following tests. Board test/Panel test/RX test/Channel test1/Channel test2/Noise test	Good/No Good	Sheet2 Installation manual
7	Setting	Check the user program setting.		Sheet3
8	Operation check	Check pictures after turning on the power.	Good/No Good	

DATA SHEET 1

General check

CK; DT: digital tester AT: analog tester OS:oscilloscope WC:watch

Check item	Content	Check point	CK	Standard	Judge
Connection	All connection should be checked referring to the interconnection diagram.	1.Transducer-transceiver unit 2.Processor unit-Transceiver unit 3.Processor unit-Control unit 4.Processor unit-Others equipment 5.Ship's mains-Power supply unit-Processor unit	WC	Refer to installation manual	
Grounding	All grounding should be checked by installation manual.	1.Monitor unit 2.Processor unit 3.Transceiver unit 4.Power supply unit 5.Junction box(Optional)	WC	Refer to installation manual	

Power Supply(ship's main voltage)

Unit	Check point	CK	Standard	Result	Judge
Processor unit	CN-A110	DT	AC100/110/115/220/230V±10%		
Transceiver unit	TB-B101 #1---#2	DT	AC90V to AC115V		
Power supply unit	TB-D102	DT	AC100/110/115/220/230V±10%		
Hull unit	TB-C101	DT	AC220V		

Note that: The input voltage may be dropped while the capacitors are being charged before transmission. For accurate data, please check the voltages during TX on and off as well when you check the input voltage of a transceiver unit.

The input voltage monitoring circuit in transceiver unit detects low voltage when AC 100V power source drops to 85V. On the other hand, if the input voltage is 120 to 130V, the over voltage flag is set and an alarm is displayed to monitor.

DATA SHEET 2

DISPALY UNIT (FSV-2400)

Check item	Contents	Check point	CK	Standard	Result	Judge
Software version	Check software version on the each board	Self-check display	WC			
	DCON 1050714***					
	DUAL 1050703***					
	IFES 1050711***					
	KEY 1050685***					
	TRCPU 1050717*** TRX 1050665*** to 1050684***					

TRANSCEIVER UNIT(FSV-241)

Check item	Contents	Check point	CK	Meter reading	Result	Judge
TX output	Check transmission output power voltage at following conditions: Range: 1000m TX setting: 9-9-9 Tilt: 0 Stabilize.: OFF TX weight: all 1 Measuring point TP108-137 Measure peak-to-peak voltage at 5ms from the leading edge of the transmission pulse. There are 15 channels of TX_P/N on each TRX board. (Totally 600ch)	Test points on the TRX boards.	OS	See fig 1		
		1 st layer				
		2 nd layer				
		3 rd layer				
		4 th layer				
		5 th layer				
		6 th layer				
		7 th layer				
		8 th layer				
		9 th layer				
		10 th layer				
		11 th layer				
		12 th layer				
		13 th layer				
		14 th layer				
		15 th layer				
		16 th layer				
		17 th layer				
		18 th layer				
		19 th layer				
20 th layer						

Fig 1 TX output power and B voltage

Normally, the output power voltage should read 1400Vp-p. However, it varies within ±15% because of transducer impedance. B voltage is normally 120V at each transmission.

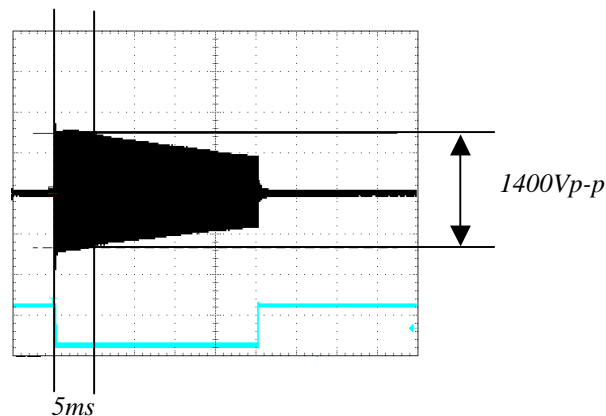

DATA SHEET 3

User menu

<i>H-scan setting</i>	<i>P1</i>	<i>P2</i>	<i>P3</i>	<i>P4</i>	<i>P5</i>	<i>P6</i>	<i>P7</i>	<i>P8</i>	<i>P9</i>	<i>P10</i>
Range										
Gain										
Tilt										
Tx interval										
Pulse length										
Tx output										
TVG near										
TVG middle										
TVG far										
NL										
AGC										
2AGC										
Echo average										
IR										
Color										
Color curve	<i>Write by color response curve sheet.</i>									
Display gain										
Delete color										
Far TVG curve										
Beamwidth-H										

<i>V-scan setting</i>	<i>P1</i>	<i>P2</i>	<i>P3</i>	<i>P4</i>	<i>P5</i>	<i>P6</i>	<i>P7</i>	<i>P8</i>	<i>P9</i>	<i>P10</i>
Range										
Gain										
Tx interval										
Pulse length										
TVG Near										
TVG middle										
TVG far										
NL										
AGC										
Echo average										
IR										
Color										
Color curve	<i>Write by color response curve sheet.</i>									
Display gain										
Delete color										
Far TVG curve										
Beamwidth-V										

TRX setting1

TRX setting1	P1	P2	P3	P4	P5	P6	P7	P8	P9	P10
TX weight										
RX weight-H										
RX weight-V										
Auto filter										
Bandwidth										
COR start distance										
COR window length										
Gain at COR										

TRX setting2

TRX setting2	P1	P2	P3	P4	P5	P6	P7	P8	P9	P10
Near TVG curve-H										
Near TVG curve-V										
Near gain-H										
Near gain-V										
Pre TVG-H										
Pre TVG-V										
Post TVG-H										
Post TVG-V										
Absorption coeff.										

Color response curve sheet (H)

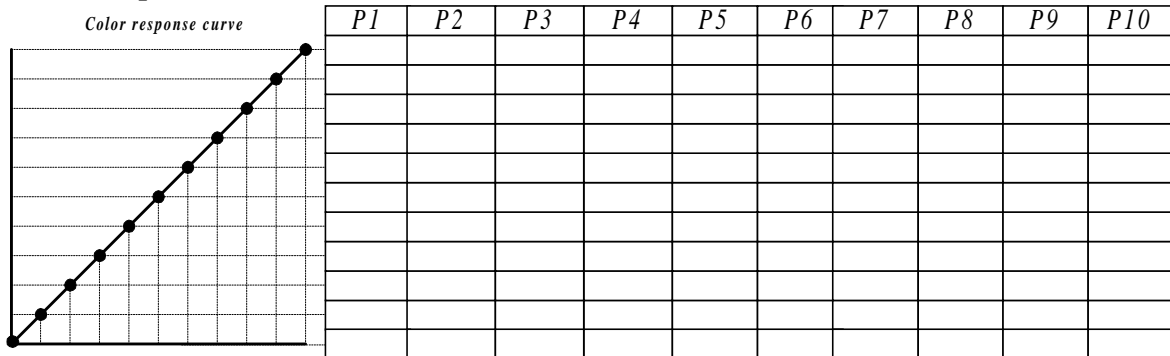

Color response curve sheet (V)

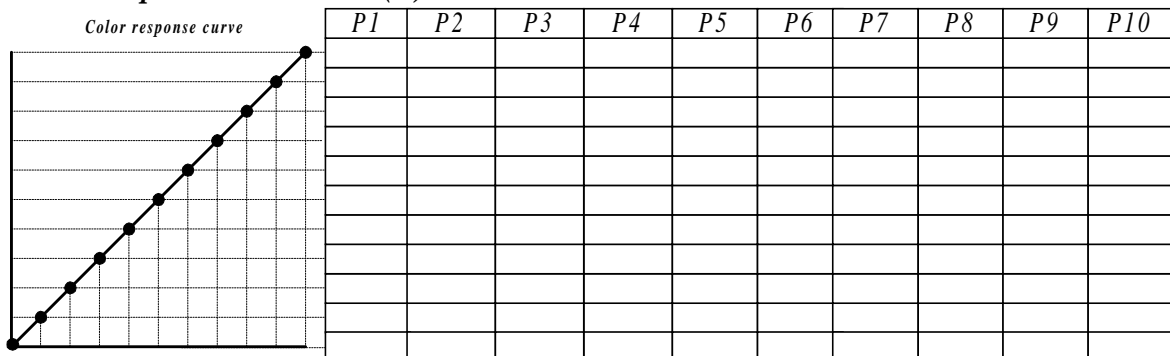

FURUNO

CODE NO.	006-921-230-00	10C0-X-9401 -6
TYPE	CP10-04501	1/1

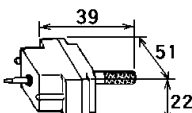
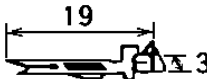
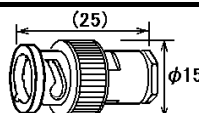
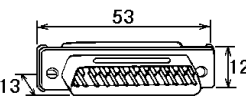
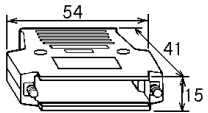
工事材料表 INSTALLATION MATERIALS					
番号 NO.	名称 NAME	略図 OUTLINE	型名/規格 DESCRIPTIONS	数量 Q'TY	用途/備考 REMARKS
1	コネクタ(8016) CONNECTOR(8016)		008016-038-313761HVF CODE NO. 000-159-017-10	1	表示部用 FOR MONITOR UNIT
2	コンタクトピン(8017) CONTACT PIN(8017)		60-8017-0313-00339F+ 60-8017-0313-00-339 CODE NO. 000-159-417-10 000-519-542-00	2	表示部用 FOR MONITOR UNIT
3	コネクタ(BNC) CONNECTOR(BNC)		BNC-P-2.5 BNC-P-2.5 CODE NO. 000-165-521-10 000-144-384-00	5	表示部用 FOR MONITOR UNIT
4	コネクタ(XM2) CONNECTOR(XM2)		XM2A-2501 CODE NO. 000-154-172-10	1	表示部用 FOR MONITOR UNIT
5	コネクタフード(XM2) CONNECTOR HOOD		XM2S-2513 CODE NO. 000-154-183-10	1	表示部用 FOR MONITOR UNIT

型式/コード番号が2段の場合、下段より上段に代わる過渡期品であり、どちらかが入っています。なお、品質は変わりません。

TWO TYPES AND CODES MAY BE LISTED FOR AN ITEM. THE LOWER PRODUCT MAY BE SHIPPED IN PLACE OF THE UPPER PRODUCT. QUALITY IS THE SAME.

(略図の寸法は、参考値です。 DIMENSIONS IN DRAWING FOR REFERENCE ONLY.)

FURUNO

CODE NO.	006-921-240-00	10C0-X-9402 -5
TYPE	CP10-04502	1/1

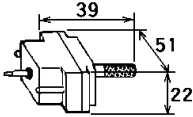
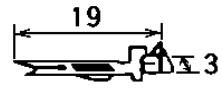
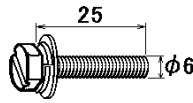
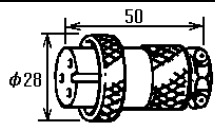
工事材料表 INSTALLATION MATERIALS					
番号 NO.	名称 NAME	略図 OUTLINE	型名/規格 DESCRIPTIONS	数量 Q'TY	用途/備考 REMARKS
1	コネクタ(8016) CONNECTOR(8016)		008016-038-313761HVF CODE NO. 000-159-017-10	1	制御部用 FOR PROCESSOR UNIT
2	コンタクトピン(8017) CONTACT PIN(8017)		60-8017-0313-00339F+ 60-8017-0313-00-339 CODE NO. 000-159-417-10 000-519-542-00	2	制御部用 FOR PROCESSOR UNIT
3	六角スリワシムス HEX. BOLT (SLOTTED, WASHER HEAD)		M6X25 SUS304 M6X25 SUS304 CODE NO. 000-162-949-10 000-802-771-00	6	制御部用 FOR PROCESSOR UNIT
4	コネクタ(NCS) CONNECTOR(NCS)		NCS-253-P *ROHS* NCS-253-P CODE NO. 000-160-153-10 000-506-503-10	1	制御部用 FOR PROCESSOR UNIT

型式/コード番号が2段の場合、下段より上段に代わる過渡期品であり、どちらかが入っています。なお、品質は変わりません。

TWO TYPES AND CODES MAY BE LISTED FOR AN ITEM. THE LOWER PRODUCT MAY BE SHIPPED IN PLACE OF THE UPPER PRODUCT. QUALITY IS THE SAME.

(略図の寸法は、参考値です。 DIMENSIONS IN DRAWING FOR REFERENCE ONLY.)

10C0-X-9402

FURUNO

CODE NO.	006-921-250-00	10C0-X-9403 -4
TYPE	CP10-04503	1/1

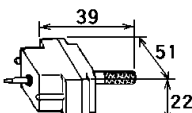
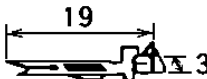
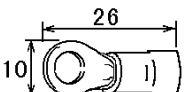
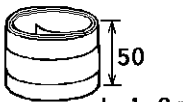
工事材料表 INSTALLATION MATERIALS					
番号 NO.	名称 NAME	略図 OUTLINE	型名/規格 DESCRIPTIONS	数量 Q'TY	用途/備考 REMARKS
1	コネクタ(8016) CONNECTOR(8016)		008016-038-313761HVF ----- 00-8016-038-313761HV CODE NO. 000-159-017-10 ----- 000-127-234-00	1	送受信装置用 FOR TRANSCEIVER UNIT
2	コンタクトピン(8017) CONTACT PIN (8017)		60-8017-0313-00339F+ ----- 60-8017-0313-00-339 CODE NO. 000-159-417-10 ----- 000-519-542-00	2	送受信装置用 FOR TRANSCEIVER UNIT
3	圧着端子 CRIMP-ON LUG		----- FV5.5-4 CODE NO. ----- 000-538-123-00	2	送受信装置用 FOR TRANSCEIVER UNIT
4	アース板 COPPER STRAP		----- WEA-1004-0 CODE NO. ----- 500-310-040-00	1	送受信装置用 FOR TRANSCEIVER UNIT

型式/コード番号が2段の場合、下段より上段に代わる過渡期品であり、どちらかが入っています。なお、品質は変わりません。



TWO TYPES AND CODES MAY BE LISTED FOR AN ITEM. THE LOWER PRODUCT MAY BE SHIPPED IN PLACE OF THE UPPER PRODUCT. QUALITY IS THE SAME.

(略図の寸法は、参考値です。 DIMENSIONS IN DRAWING FOR REFERENCE ONLY.)

10C0-X-9403

FURUNO

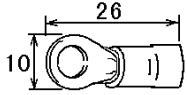
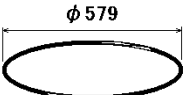
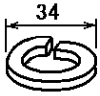
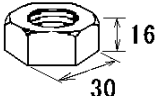
CODE NO.		10CO-X-9412 -1
TYPE		1/1

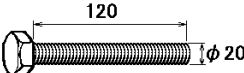
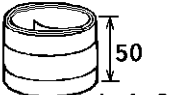
工事材料表 INSTALLATION MATERIALS		FSV-247/248			
番号 NO.	名称 NAME	略図 OUTLINE	型名/規格 DESCRIPTIONS	数量 Q'TY	用途/備考 REMARKS
1	圧着端子 CRIMP-ON LUG		FV5.5-4 CODE NO. 000-538-123-00	3	
2	Oリング O-RING		JISB2401-1A-V585 CODE NO. 000-851-421-00	1	
3	バネ座金 SPRING WASHER		M20 SUS304 CODE NO. 000-864-270-00	19	
4	六角ナット 1種 HEX. NUT		M20 SUS304 CODE NO. 000-863-116-00	38	
5	ミガキ平座金 FLAT WASHER		M20 SUS304 CODE NO. 000-864-136-00	33	
6	六角ボルト HEX. BOLT		M20X120 SUS304 CODE NO. 000-806-235-00	14	
7	アース板 COPPER STRAP		WEA-1004-0 CODE NO. 500-310-040-00	1	

型式/コード番号が2段の場合、下段より上段に代わる過渡期品であり、どちらかが入っています。なお、品質は変わりません。

TWO TYPES AND CODES MAY BE LISTED FOR AN ITEM. THE LOWER PRODUCT MAY BE SHIPPED IN PLACE OF THE UPPER PRODUCT. QUALITY IS THE SAME.

(略図の寸法は、参考値です。 DIMENSIONS IN DRAWING FOR REFERENCE ONLY.)

10CO-X-9412

FURUNO

A-5

CODE NO.	006-666-666	10C0-X-9405-0 1/1
TYPE	CP10-04505	

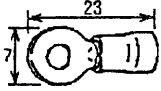
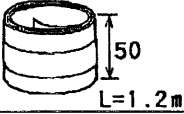
工事材料表 INSTALLATION MATERIALS		FSV-242			
番号 NO.	名称 NAME	略図 OUTLINE	型名/規格 DESCRIPTIONS	数量 Q'TY	用途/備考 REMARKS
1	圧着端子 CRIMP-ON LUG		FV5.5-S4	4	電源装置用 FOR POWER SUPPLY UNIT
			CODE NO. 000-538-121		
2	銅入板 COPPER STRAP		WEA-1004-0	1	電源装置用 FOR POWER SUPPLY UNIT
			CODE NO. 500-310-040		

DWG NO.

C1318-M05- A

FURUNO ELECTRIC CO., LTD.

(略図の寸法は、参考値です。 DIMENSIONS IN DRAWING FOR REFERENCE ONLY.)

FURUNO

CODE NO.	006-921-290-00	10C0-X-9406 -3
TYPE	CP10-04506	1/1

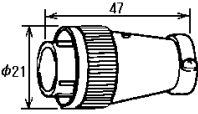
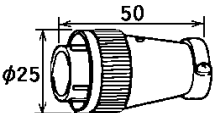
工事材料表 INSTALLATION MATERIALS					
番号 NO.	名称 NAME	略図 OUTLINE	型名/規格 DESCRIPTIONS	数量 Q'TY	用途/備考 REMARKS
1	コネクタ(SRCN) CONNECTOR(SRCN)		SRCN6A13-5P	1	
			CODE NO. 000-160-726-10		
2	コネクタ(SRCN) CONNECTOR(SRCN)		SRCN6A16-10P	1	
			CODE NO. 000-160-728-10		

型式/コード番号が2段の場合、下段より上段に代わる過渡期品であり、どちらかが入っています。なお、品質は変わりません。

TWO TYPES AND CODES MAY BE LISTED FOR AN ITEM. THE LOWER PRODUCT MAY BE SHIPPED IN PLACE OF THE UPPER PRODUCT. QUALITY IS THE SAME.

(略図の寸法は、参考値です。 DIMENSIONS IN DRAWING FOR REFERENCE ONLY.)

FURUNO

CODE NO.	006-934-240-00	10CO-X-9410 -1
TYPE	CP10-04801	1/1

工事材料表 INSTALLATION MATERIALS					
番号 NO.	名称 NAME	略図 OUTLINE	型名/規格 DESCRIPTIONS	数量 Q'TY	用途/備考 REMARKS
1	コネクタ(SRCN) CONNECTOR(SRCN)		SRCN6A13-3P CODE NO. 000-508-660-00	1	
2	コネクタ(SRCN) CONNECTOR(SRCN)		SRCN6A16-10P CODE NO. 000-160-728-10	1	
3	コネクタ(SRCN) CONNECTOR(SRCN)		SRCN6A16-7P CODE NO. 000-160-730-10	1	
4	コネクタ(SRCN) CONNECTOR(SRCN)		SRCN6A21-10P CODE NO. 000-160-735-10	1	
5	コネクタ(SRCN) CONNECTOR(SRCN)		SRCN6A21-10S CODE NO. 000-160-736-10	1	

型式/コード番号が2段の場合、下段より上段に代わる過渡期品であり、どちらかが入っています。なお、品質は変わりません。

TWO TYPES AND CODES MAY BE LISTED FOR AN ITEM. THE LOWER PRODUCT MAY BE SHIPPED IN PLACE OF THE UPPER PRODUCT. QUALITY IS THE SAME.

(略図の寸法は、参考値です。 DIMENSIONS IN DRAWING FOR REFERENCE ONLY.)

FURUNO

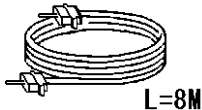
		CODE NO.			10C0-X-9408 -3
		TYPE			1/1
工事材料表		FSV-24/24S			
INSTALLATION MATERIALS					
番号 NO.	名称 NAME	略図 OUTLINE	型名/規格 DESCRIPTIONS	数量 Q'TY	用途/備考 REMARKS
1	ケーブル(組品) CABLE ASSY.	 L=8M	10S2078 ----- 10S2078 CODE NO. 000-160-862-10 ----- 000-144-389-00	1	送受信装置 - 上下装置



型式/コード番号が2段の場合、下段より上段に代わる過渡期品であり、どちらかが入っています。なお、品質は変わりません。

TWO TYPES AND CODES MAY BE LISTED FOR AN ITEM. THE LOWER PRODUCT MAY BE SHIPPED IN PLACE OF THE UPPER PRODUCT. QUALITY IS THE SAME.

(略図の寸法は、参考値です。 DIMENSIONS IN DRAWING FOR REFERENCE ONLY.)

FURUNO

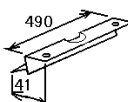
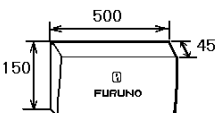
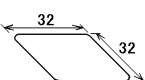
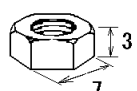
CODE NO.	006-922-390-00	10C0-X-9501 -2
TYPE	FP10-02201	1/1

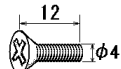
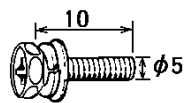
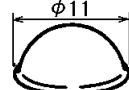

付属品表					
ACCESSORIES					
番号 NO.	名称 NAME	略図 OUTLINE	型名/規格 DESCRIPTIONS	数量 Q'TY	用途/備考 REMARKS
1	KB直付け金具 KB FIXNG PLATE		03-144-1691-1 CODE NO. 100-263-941-00	1	操作部用 FOR CONTROLL UNIT
2	ダストカバー-KB DUST COVER KB		03-144-1693-0 CODE NO. 100-271-760-00	1	操作部用 FOR CONTROLL UNIT
3	コネクタシール DUMMY FILM		05-040-0108-0 CODE NO. 100-117-120-00	1	操作部用 FOR CONTROLL UNIT
4	六角ナット 1種 HEX. NUT		M4 C2700W MBN12 CODE NO. 000-863-206-00	2	操作部用 FOR CONTROLL UNIT
5	バネ座金 SPRING WASHER		M4 C5191W MBN12 CODE NO. 000-864-206-00	2	操作部用 FOR CONTROLL UNIT
6	ミガキ平座金 FLAT WASHER		M4 C2600P MBN12 CODE NO. 000-864-106-00	2	操作部用 FOR CONTROLL UNIT
7	+サラ小ネジ OVAL HEAD SCREW		M4X12 C2700W MBN12 CODE NO. 000-163-309-10	2	操作部用 FOR CONTROLL UNIT
8	+アワセットUIセムズ +HEX. BOLT (WASHER HEAD)		M5X10 SUS304 CODE NO. 000-163-757-10	2	操作部用 FOR CONTROLL UNIT
9	ゴム足 RUBBER FEET		SJ-5003 如 SJ-5003 如 CODE NO. 000-165-669-10 000-801-787-00	4	操作部用 FOR CONTROLL UNIT

型式/コード番号が2段の場合、下段より上段に代わる過渡期品であり、どちらかが入っています。なお、品質は変わりませ

ん。
TWO TYPES AND CODES MAY BE LISTED FOR AN ITEM. THE LOWER PRODUCT MAY BE SHIPPED IN PLACE OF THE UPPER PRODUCT. QUALITY IS THE SAME.

(略図の寸法は、参考値です。 DIMENSIONS IN DRAWING FOR REFERENCE ONLY.)

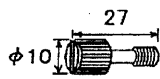
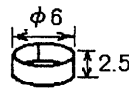
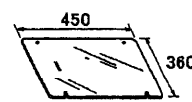
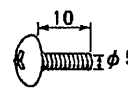
CODE NO.	006-924-320	10C0-X-9503 -0 1/1
TYPE	FP10-02202	

付属品表 ACCESSORIES					
番号 NO.	名称 NAME	略図 OUTLINE	型名/規格 DESCRIPTIONS	数量 Q'TY	用途/備考 REMARKS
1	フードビス HOOD RETAINER		03-144-1336-1	2	表示部用 FOR MONITOR UNIT
			CODE NO. 100-266-311		
2	マキスペーサー SPACER		5X2.5	2	表示部用 FOR MONITOR UNIT
			CODE NO. 000-808-429		
3	CRTフィルター FILTER		10-071-1141-0	1	表示部用 FOR MONITOR UNIT
			CODE NO. 100-289-020		
4	トラスネジ SCREW		M5X10 C2700W	2	表示部用 FOR MONITOR UNIT
			CODE NO. 000-808-430		
5	抜け止めワッシャー WASHER		TM-147-3	2	表示部用 FOR MONITOR UNIT
			CODE NO. 000-801-878		

DWG NO. C1318-F02- B

FURUNO ELECTRIC CO., LTD.

(略図の寸法は、参考値です。 DIMENSIONS IN DRAWING FOR REFERENCE ONLY.)

FURUNO

A-10

CODE NO.	006-924-350	10C0-X-9504 -0
TYPE	FP10-02203	1/1

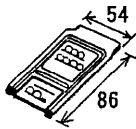
付属品表 ACCESSORIES					
番号 NO.	名称 NAME	略図 OUTLINE	型名/規格 DESCRIPTIONS	数量 Q'TY	用途/備考 REMARKS
1	(組)メモリーカード MEMORY CARD		FP10-02204 CODE NO. 006-924-850	1	



DWG NO. C1318-F03- A

FURUNO ELECTRIC CO., LTD.

(略図の寸法は、参考値です。 DIMENSIONS IN DRAWING FOR REFERENCE ONLY.)

FURUNO

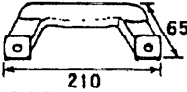
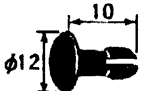
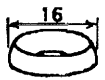
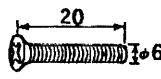
CODE NO.	008-478-830	03FS-X-9501 -5
TYPE	FPO3-06201	1/1

付属品表					
ACCESSORIES					
番号 NO.	名称 NAME	略図 OUTLINE	型名/規格 DESCRIPTIONS	数量 Q'TY	用途/備考 REMARKS
1	取手 HANDLE		14-002-1125-2	2	
			CODE NO. 840-211-252		
2	プラスチックボルト PLASTIC RIVET		KB-1339 ボルト付	4	
			CODE NO. 000-570-276		
3	ロゼット座金 ROSETTE WASHER		M6 C2700W ボルト用 クロ	4	
			CODE NO. 000-864-910		
4	丸皿小ネジ OVAL COUNTERSUNK HEAD SCREW		M6X20 C2700W ボルト用 クロ	4	
			CODE NO. 000-861-475		
5	波座金 WAVE WASHER		NW-6 SUS	4	
			CODE NO. 000-864-350		

DWG NO.
C3464-F01- F

FURUNO ELECTRIC CO., LTD.

(略図の寸法は、参考値です。 DIMENSIONS IN DRAWING FOR REFERENCE ONLY.)

表 1 TABLE 1

寸法区分(mm) DIMENSIONS	公差(mm) TOLERANCE
0 < L ≤ 50	±1.5
50 < L ≤ 100	±2.5
100 < L ≤ 500	±3
500 < L ≤ 1000	±4

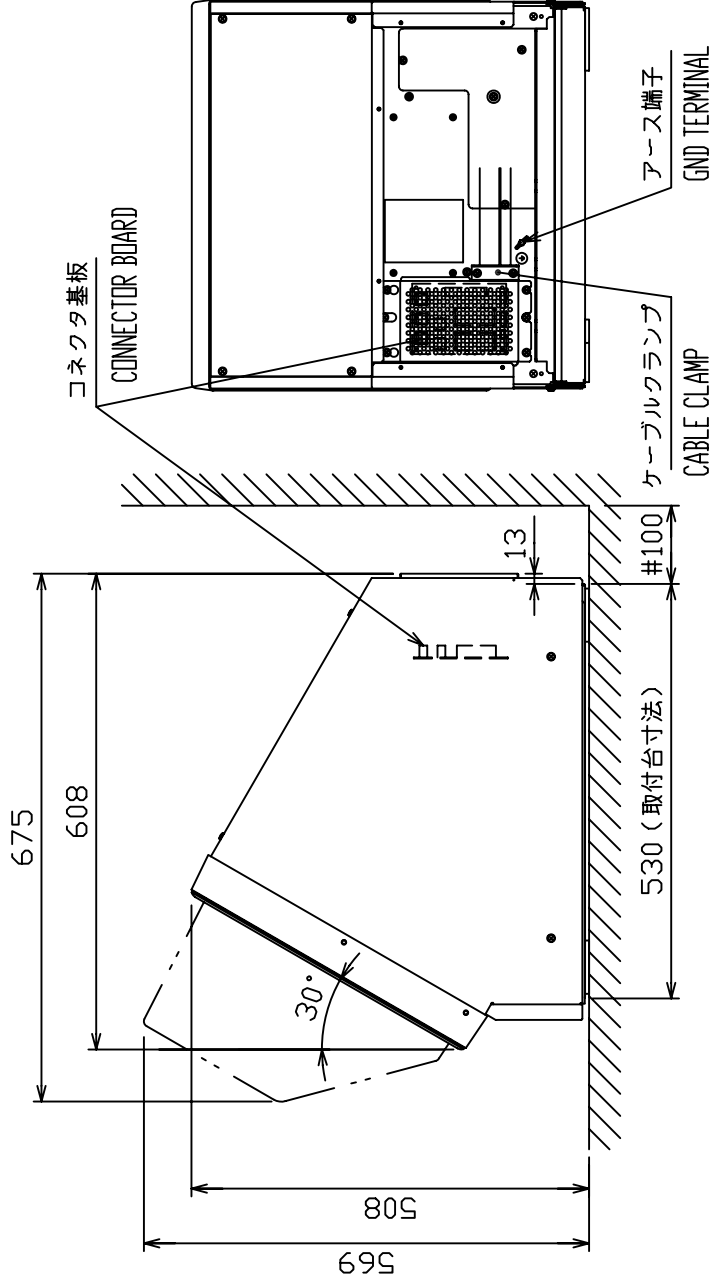
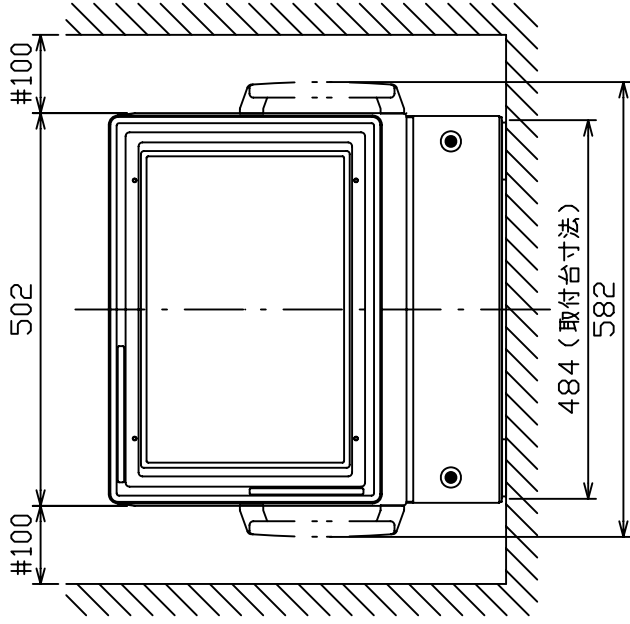
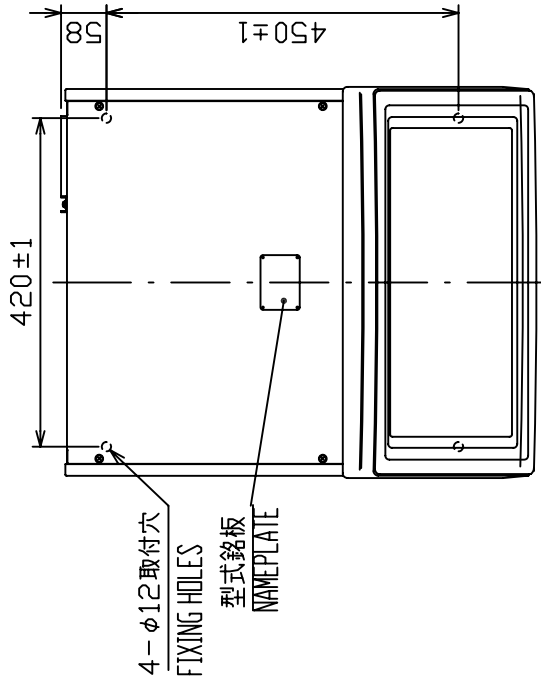

注 記
 1) #印寸法は最小サービス空間寸法とする。
 2) 指定外の寸法公差は表1による。
 3) 取付用ネジはM10ボルト、またはコーチボルト呼び径φを使用のこと。
 NOTE
 1. # MINIMUM SERVICE CLEARANCE.
 2. TABLE 1 INDICATES TOLERANCE OF DIMENSIONS WHICH IS NOT SPECIFIED.
 3. USE M10 BOLTS OR COARCH SCREWS φ9 FOR FIXING THE UNIT.

DRAWN JUL 28 '06 E. MIYOSHI	TITLE FSV-2400
CHECKED TAKAHASHI, T	名称 表示部
APPROVED Y. Hatai	外寸図
SCALE 1/10 MASS 48 ±10% kg	NAME MONITOR UNIT
DWG. No. C1318-601-D	10-071-100G-3
OUTLINE DRAWING	

490

450±1

FIXING HOLES
2-φ6.5 (取付穴)

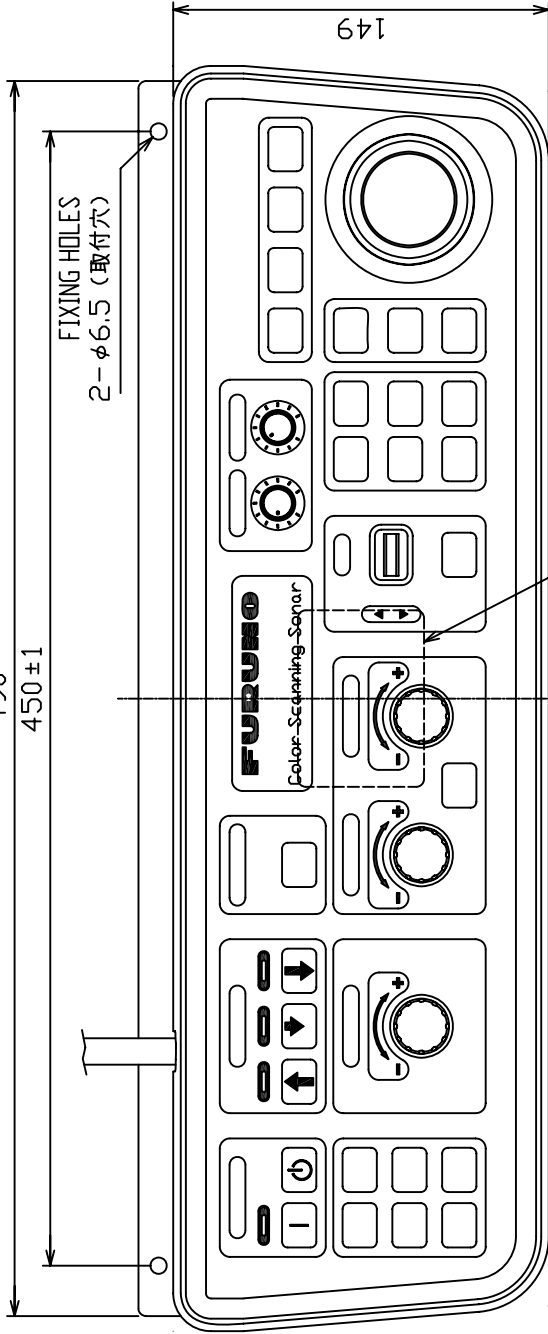

149

矢視 A
VIEW A

ユニット銘板
NAMEPLATE BOTTOM

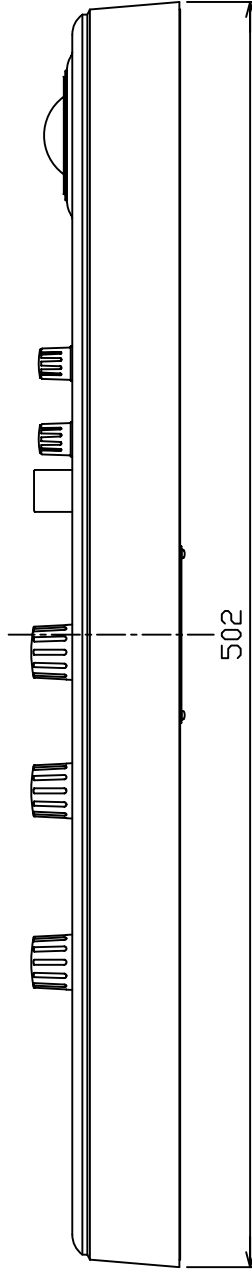

502

- 注記 1) #印寸法は最小サービス空間寸法とする。
 2) 指定外の寸法公差は表1による。
 3) 質量はKB直付け金具、及びケーブル(5m)を含む。
 4) 取付用ネジはトラスタップピンネジ呼び径5、またはM5ボルトを使用のこと。

矢視 B
VIEW B



表 1 TABLE 1

寸法区分 (mm) DIMENSIONS	公差 (mm) TOLERANCE
L ≤ 50	±1.5
50 < L ≤ 100	±2.5
100 < L ≤ 500	±3
500 < L ≤ 1000	±4

- NOTE 1. # MINIMUM SERVICE CLEARANCE.
 2. TABLE 1 INDICATES TOLERANCE OF DIMENSIONS WHICH IS NOT SPECIFIED.
 3. MASS INCLUDES KB FIXING PLATE AND CABLE (5M).
 4. USE M5 BOLTS OR TAPPING SCREWS φ5 FOR FIXING THE UNIT.

DRAWN AUG. 21.06 Maki	TITLE FSV-240/300/8401
CHECKED TAKAHASHI, T	名称 操作部 (KB直付け金具あり)
APPROVED Y. Hatai	FSV-240/300 質量はケーブル重さを含む。 MASS W/ CABLE.
SCALE 1/3	NAME CONTROL UNIT (w/KB FIXING PLATE)
DWG No. C1318-603-E	10-079-200G-0 OUTLINE DRAWING

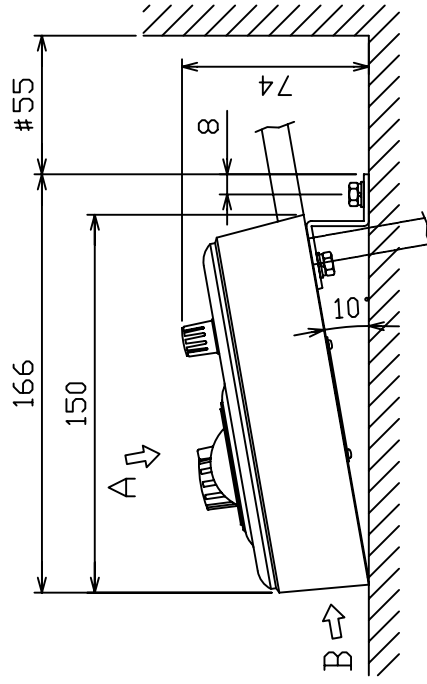
表 1 TABLE 1

寸法区分 (mm) DIMENSIONS	公差 (mm) TOLERANCE
L ≤ 50	± 1.5
50 < L ≤ 100	± 2.5
100 < L ≤ 500	± 3
500 < L ≤ 1000	± 4

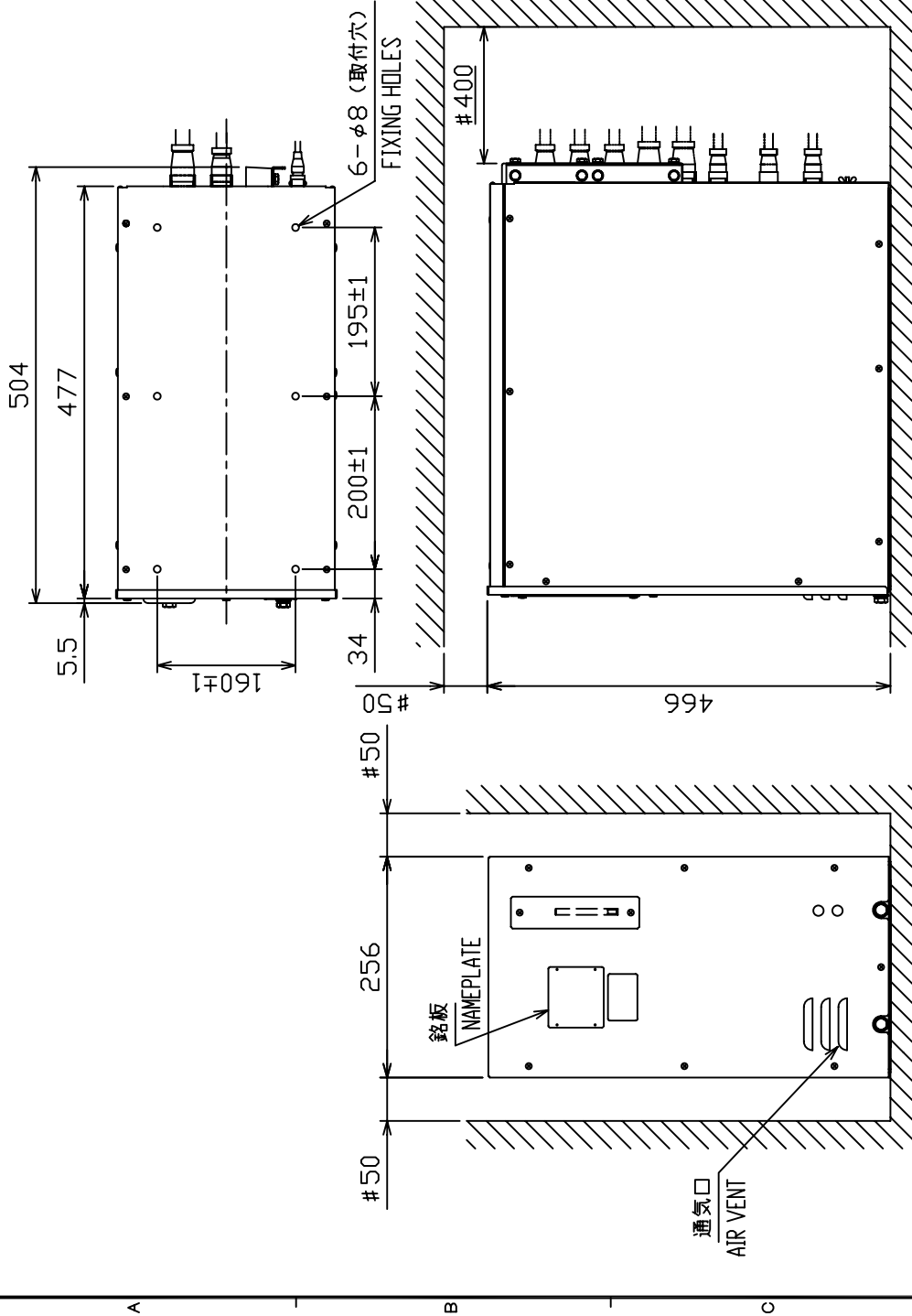

- 注記 1) #印寸法は最小サービスペース寸法とする。
 2) 指定外の寸法公差は表1による。
 3) 取付用ネジはM6ボルトを使用のこと。
 4) 装備ケーブルはサービスペース時、筐体を前方に十分引き出せるよう余裕を持たせること。

- NOTE 1. # MINIMUM SERVICE CLEARANCE.
 2. TABLE 1 INDICATES TOLERANCE OF DIMENSIONS WHICH IS NOT SPECIFIED.
 3. USE M6 BOLTS FOR FIXING THE UNIT.
 4. KEEP SUFFICIENT CABLE LENGTH BEHIND UNIT.

DRAWN 28.06 E. MIYOSHI	TITLE FSV-2402/2402S/3002/3002S/8402
CHECKED TAKAHASHI, T	名称 制御部
APPROVED Y. Hatai	FSV-24/24S/30/30S84/84L
SCALE 1/8 MASS 29.0 kg	外寸図
DWG No. C1318-602-E	NAME PROCESSOR UNIT
10-079-300G-0	OUTLINE DRAWING

表 1 TABLE 1

寸法区分 (mm) DIMENSION	公差 (mm) TOLERANCE
L ≤ 50	± 1.5
50 < L ≤ 100	± 2.5
100 < L ≤ 500	± 3
500 < L ≤ 1000	± 4

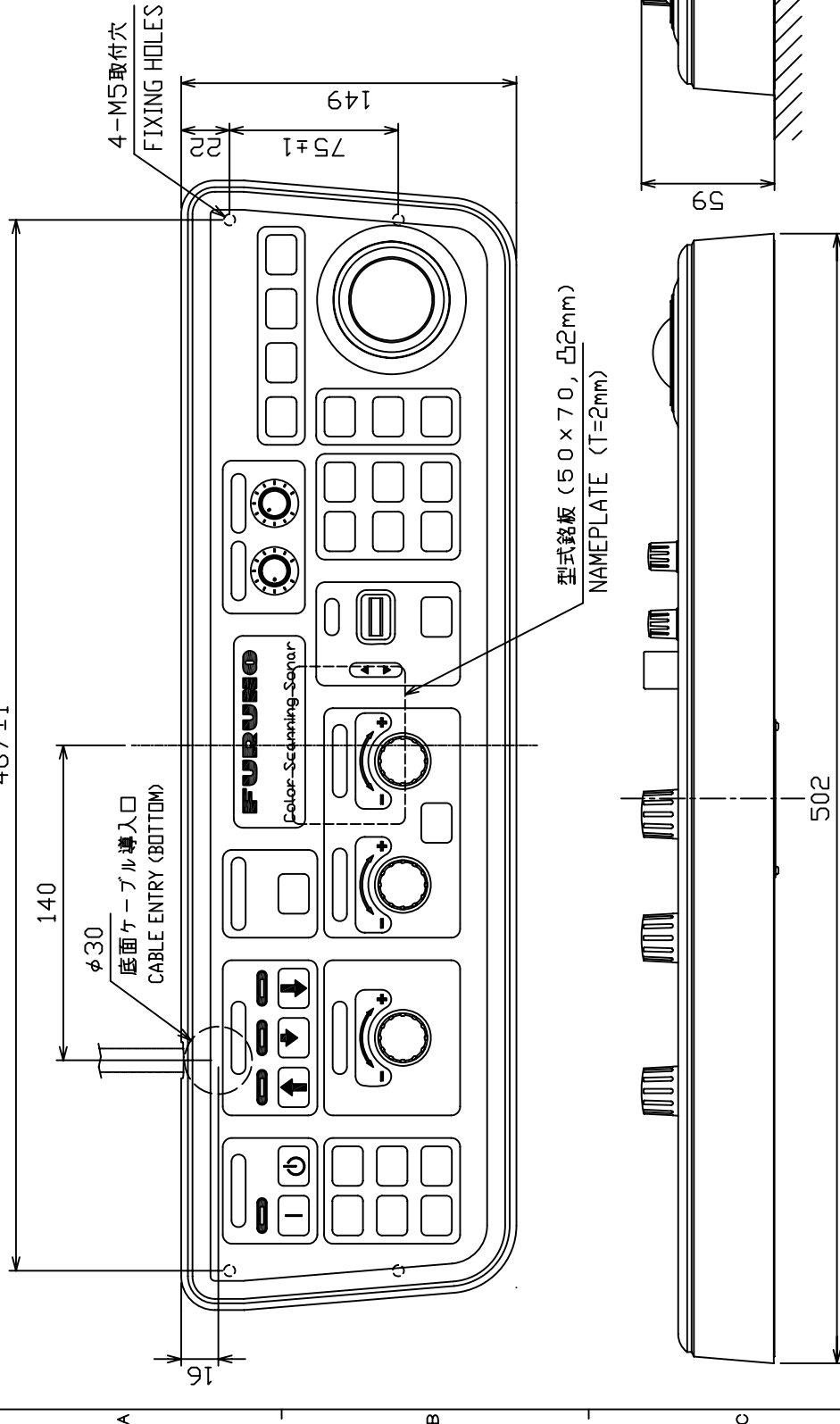

- 注 記 1) #印寸法は最小サービス空間寸法とする。
 2) 指定外の寸法公差は表 1 による。
 3) 質量は、ケーブル (5m) を含む。
 4) 取付用ネジは M5 ボルトを使用のこと。但し、ボルトが内部に 20 mm 以上入り込まないこと。

- NOTE 1. # MINIMUM SERVICE CLEARANCE.
 2. TABLE 1 INDICATES TOLERANCE OF DIMENSIONS WHICH IS NOT SPECIFIED.
 3. MASS W/CABLE (5M).
 4. USE M5 BOLTS FOR FIXING THE UNIT.
 DO NOT FASTEN BOLTS INTO UNIT MORE THAN 20 mm.

DRAWN	Aug. 21.06	Maki	TITLE	FSV-2401/3001/8401
CHECKED		TAKAHASHI, T	名称	操作部 (KB直付け金具なし)
APPROVED		Y. Hatai		外寸図
SCALE	1/3	MASS 3.6 kg	NAME	CONTROL UNIT (w/o KB FIXING PLATE)
DWG No.	C1318-G08-E	10-079-210G-0		OUTLINE DRAWING

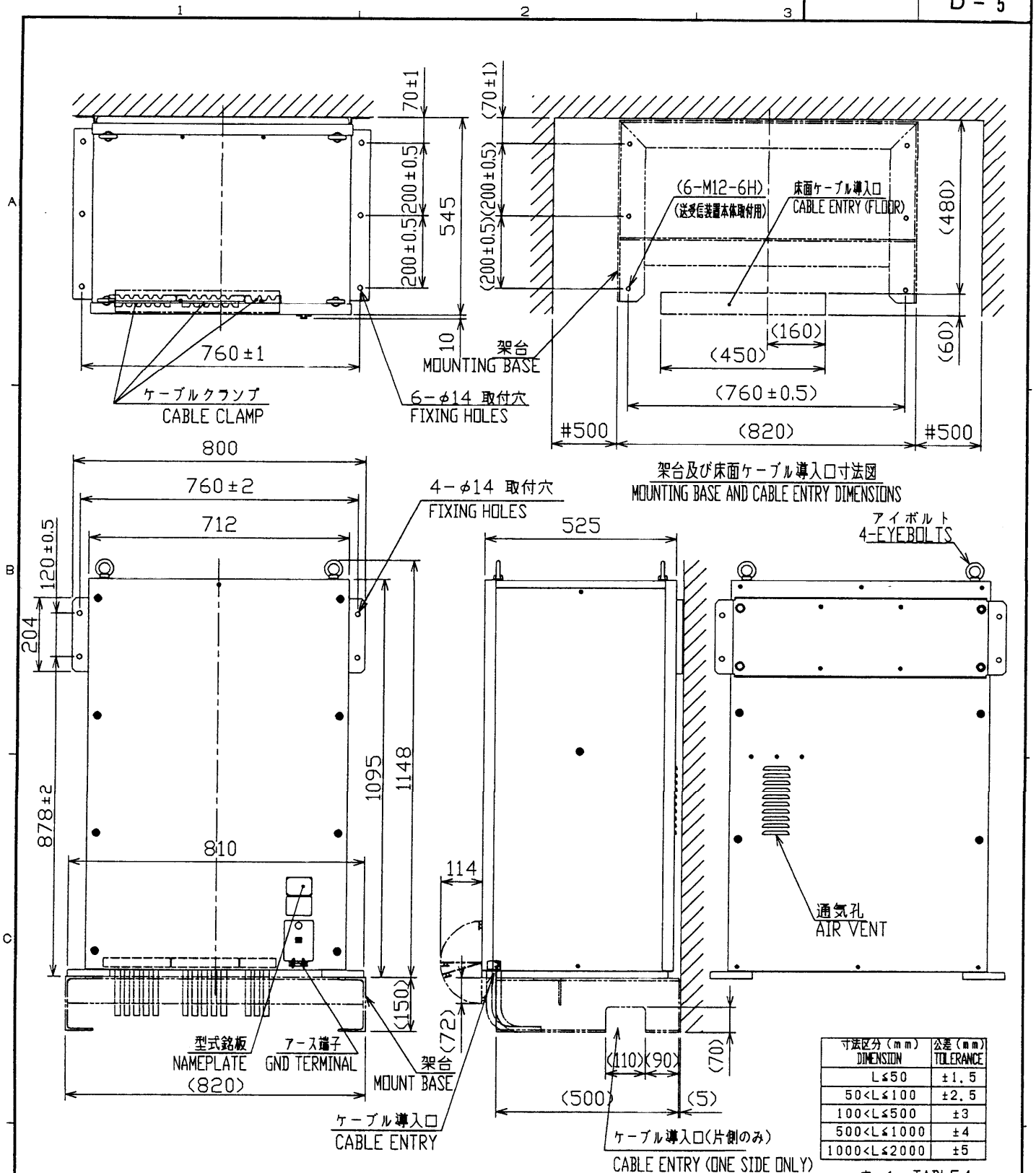

注記

- 1) #印寸法は最小サービス空間寸法とする。
- 2) 指定外の寸法公差は表1による。
- 3) 取付用ネジはM12ボルト (材質: SUS304) を使用のこと。
- 4) 架台及び床面ケーブル導入口の寸法は参考寸法とする。
直接床置きの場合のみ床面ケーブル導入口を設け、架台取付けの場合架台は造船所手配とする。(架台材質: SS400)

NOTE

1. #: RECOMMENDED SERVICE CLEARANCE.
2. TABLE 1 INDICATES TOLERANCE OF DIMENSIONS.
3. USE M12 BOLTS FOR FIXING THE UNIT.
4. DIMENSIONS OF MOUNTING BASE AND CABLE ENTRY ARE REFERENCE ONLY. A MOUNTING BASE (SS400) SHOULD BE SUPPLIED BY SHIPYARD. MAKE A CABLE ENTRY HOLE WHEN THE MOUNTING BASE IS NOT USED.

表 1 TABLE 1

DRAWN Jan. 18 '02 T. YAMASAKI		TITLE FSV-241E
CHECKED Jan. 18 '02 Y. Kim		名称 送受信装置
APPROVED Jan. 18 '02 S. Yoshida	FSV-24/24S	外寸図
SCALE 1/15	質量 180 ±10% kg	NAME TRANSCIEVER UNIT
DWG.No. C1318-G13-A	10-071-660G-1	OUTLINE DRAWING

寸法区分 (mm) DIMENSION	公差 (mm) TOLERANCE
$L \leq 50$	± 1.5
$50 < L \leq 100$	± 2.5
$100 < L \leq 500$	± 3

表 1 TABLE 1

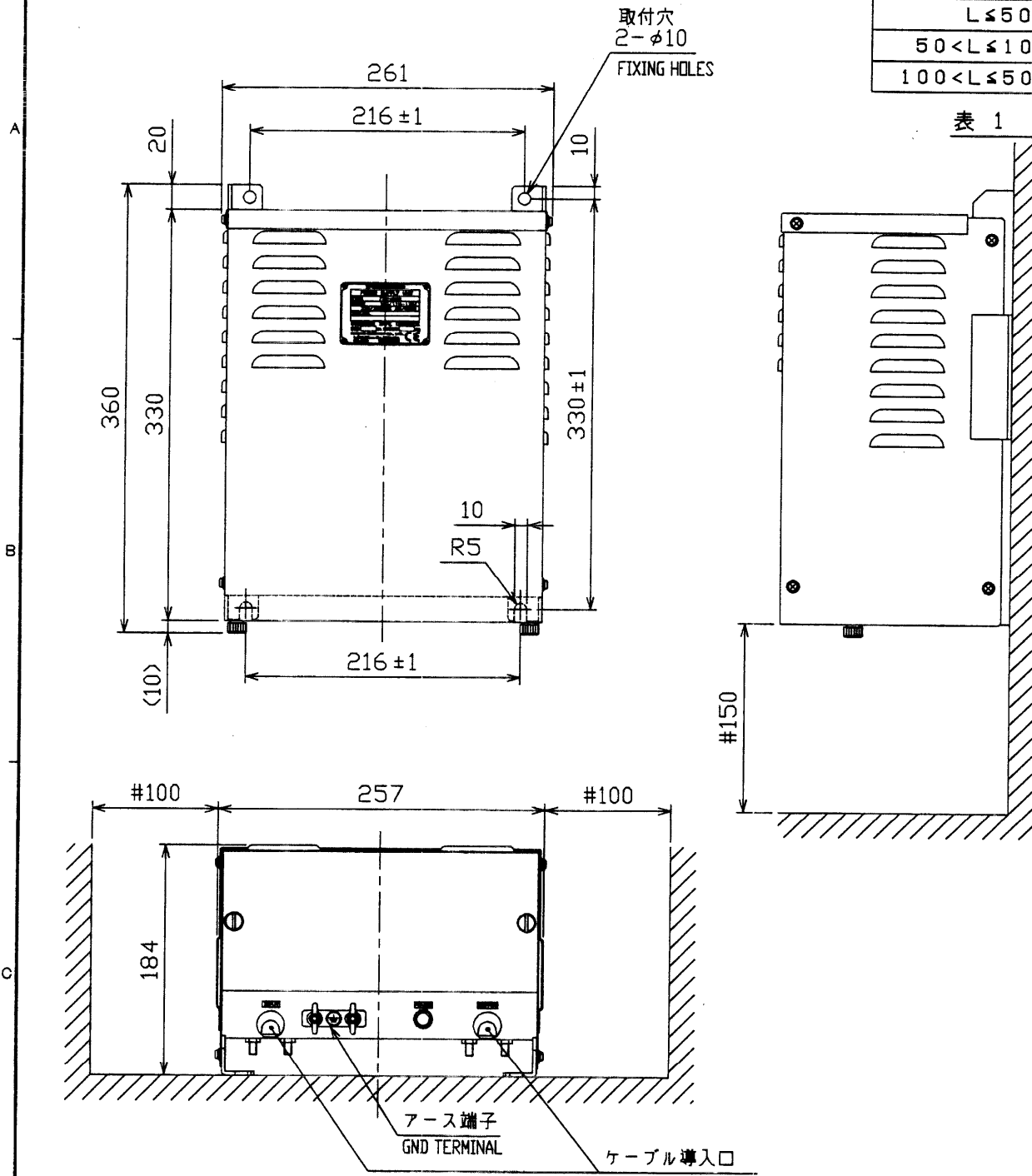

- 注 記 1) #印寸法は最小サービス空間寸法とする。
 2) 指定外の寸法公差は表 1 による。
 3) 取付用ネジは M8 ボルト、またはコーチボルト呼び径 8 を使用のこと。

- NOTE 1. #: RECOMMENDED SERVICE CLEARANCE.
 2. TABLE 1 INDICATES TOLERANCE OF DIMENSIONS.
 3. USE M8 BOLTS OR COACH BOLTS $\phi 8$ FOR FIXING THE UNIT.

DRAWN May 15 '01 T. YAMASAKI		TITLE FSV-242
CHECKED May 15 '01 Y. Kim		名称 電源装置
APPROVED May 18 '01 S. Yoshida	FSV-24	外寸図
SCALE 1/5 MASS 25 ±10% kg		NAME POWER SUPPLY
DWG.No. C1318-G07-B	10-071-900G-3	OUTLINE DRAWING

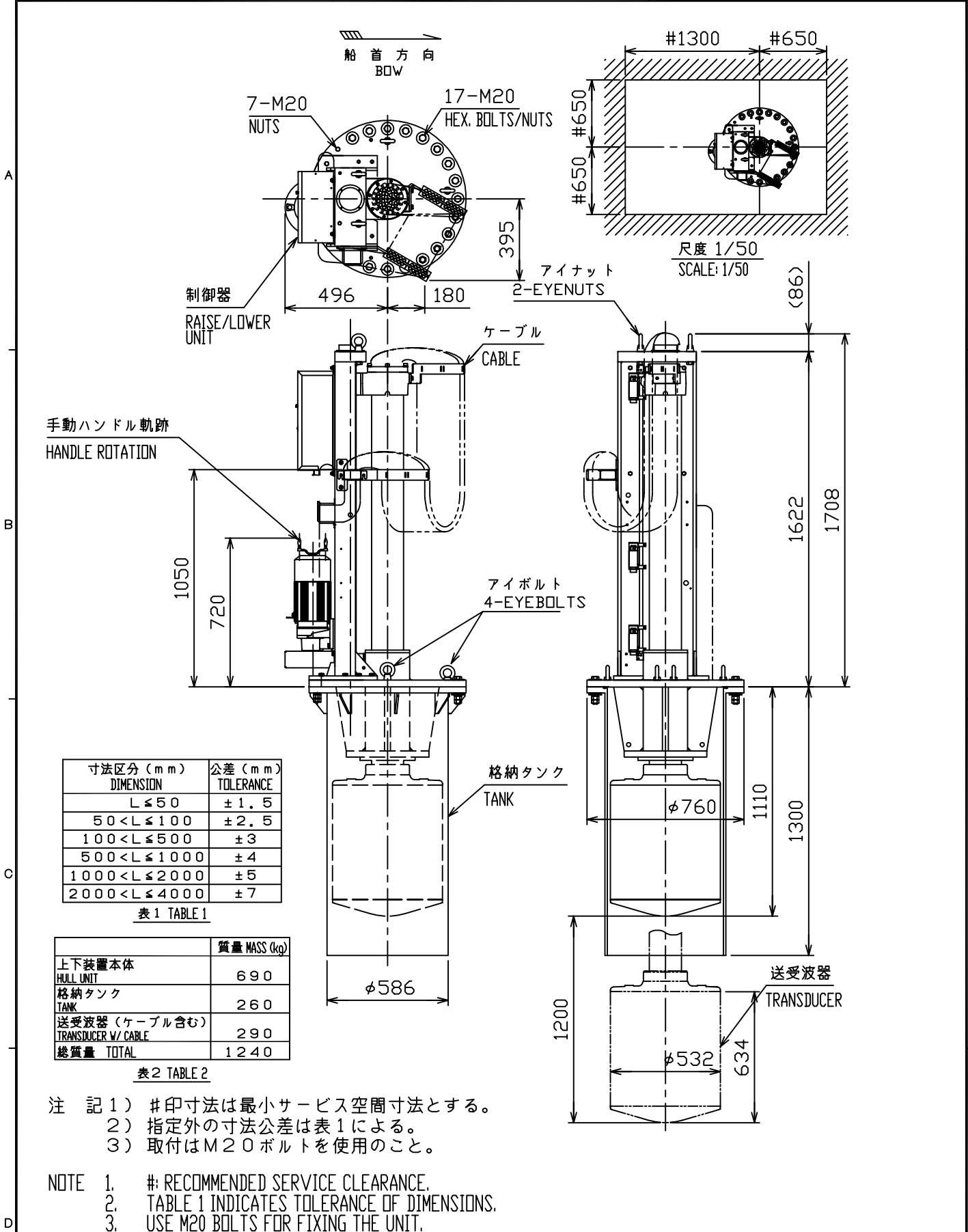

寸法区分 (mm) DIMENSION	公差 (mm) TOLERANCE
L ≤ 50	±1.5
50 < L ≤ 100	±2.5
100 < L ≤ 500	±3
500 < L ≤ 1000	±4
1000 < L ≤ 2000	±5
2000 < L ≤ 4000	±7

表1 TABLE 1

	質量 MASS (kg)
上下装置本体 HULL UNIT	690
格納タンク TANK	260
送受波器 (ケーブル含む) TRANSDUCER W/ CABLE	290
総質量 TOTAL	1240

表2 TABLE 2

- 注 記 1) #印寸法は最小サービス空間寸法とする。
 2) 指定外の寸法公差は表1による。
 3) 取付はM20ボルトを使用のこと。

- NOTE 1. #: RECOMMENDED SERVICE CLEARANCE.
 2. TABLE 1 INDICATES TOLERANCE OF DIMENSIONS.
 3. USE M20 BOLTS FOR FIXING THE UNIT.

DRAWN Jan. 28 '03 T.YAMASAKI	TITLE FSV-247
CHECKED Jan. 28 '03 Y.KIMURA	名称 上下装置 (1200mmストローク)
APPROVED Jan. 28, '03 <i>Y. Kimura</i>	外寸図
SCALE 1/25 MASS 表2参照 SEE TABLE 2	NAME HULL UNIT (1200mm TRAVEL)
DWG.No. C1318-G14-A	10-077-500G-2 OUTLINE DRAWING

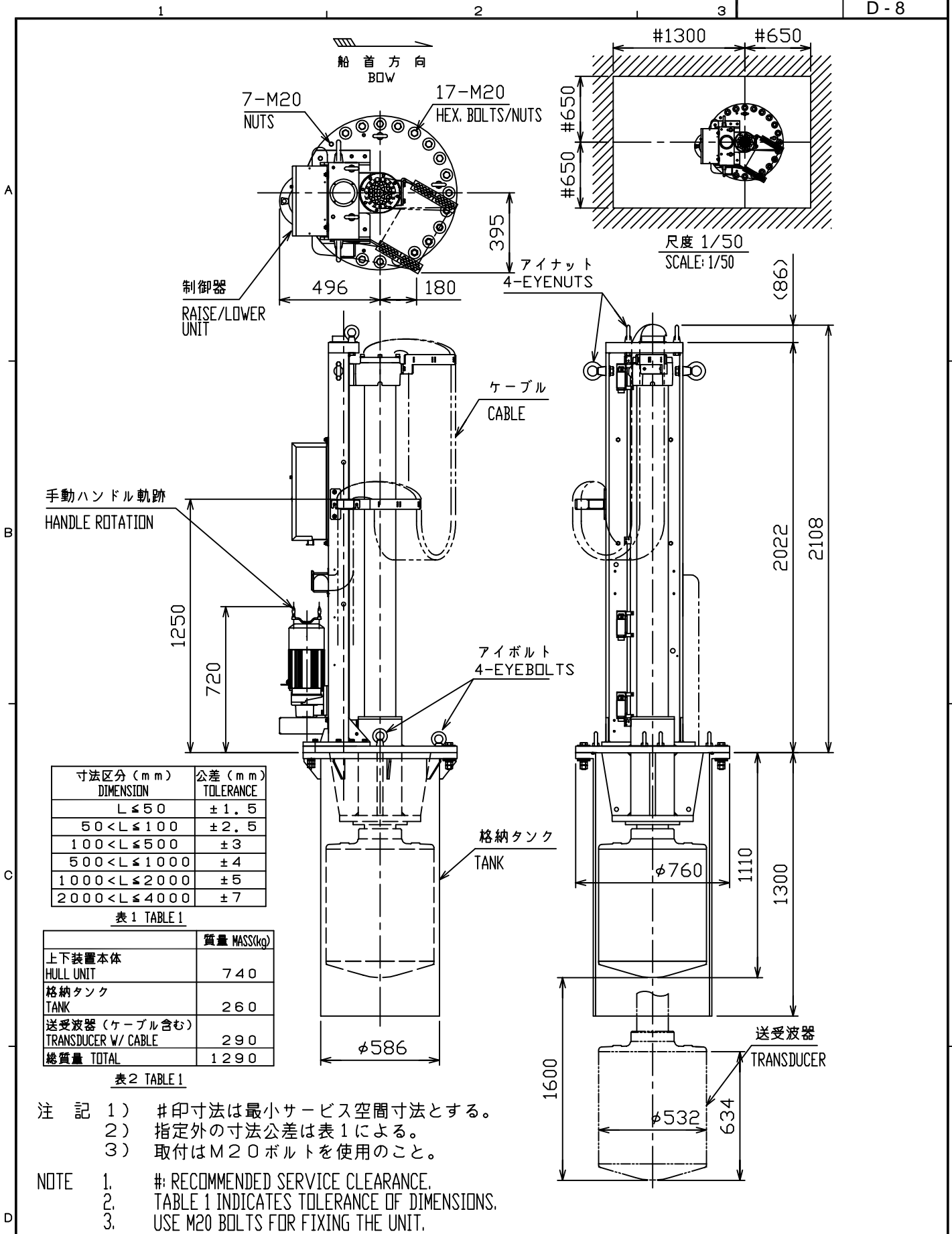

DRAWN Jan. 28 '03 T.YAMASAKI	TITLE FSV-248
CHECKED Jan. 28 '03 Y. Kimura	名称 上下装置 (1600mmストローク)
APPROVED Jan. 28, '03 Y. Kimura	外寸図
SCALE 1/25 MASS 表2参照 SEE TABLE 2	NAME HULL UNIT (1600mm TRAVEL)
DWG.No. C1318-G15-A	10-077-505G-2 OUTLINE DRAWING

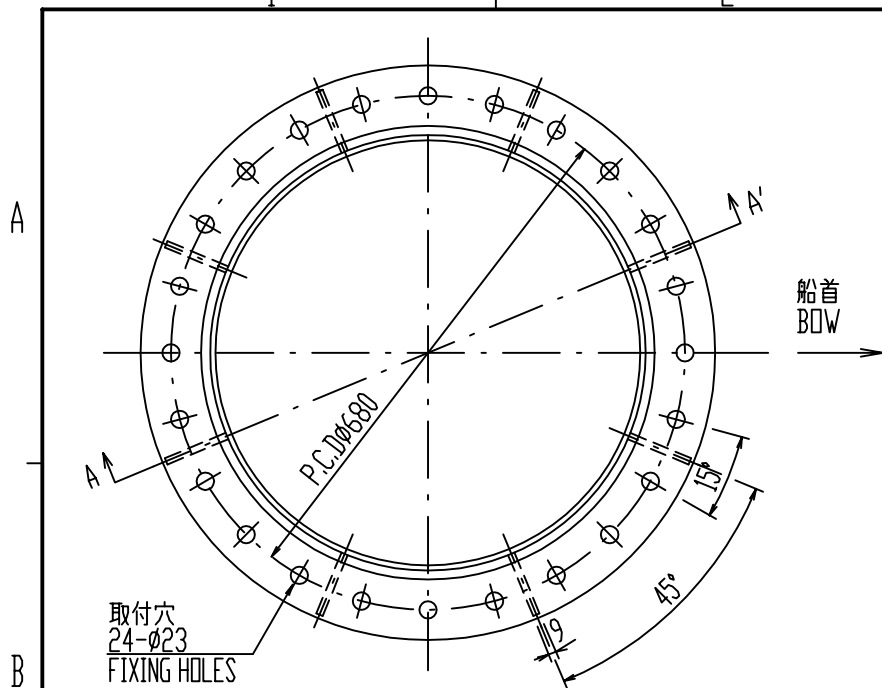

注記

1) 装備時24個のボルト穴のうち適当な1個を船首方向に一致させる。

NOTE

1. ONE OF 24 BOLT HOLES SHOULD BE FACED DEAD AHEAD.

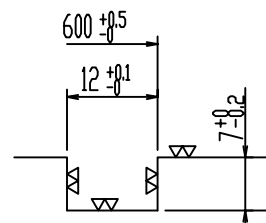
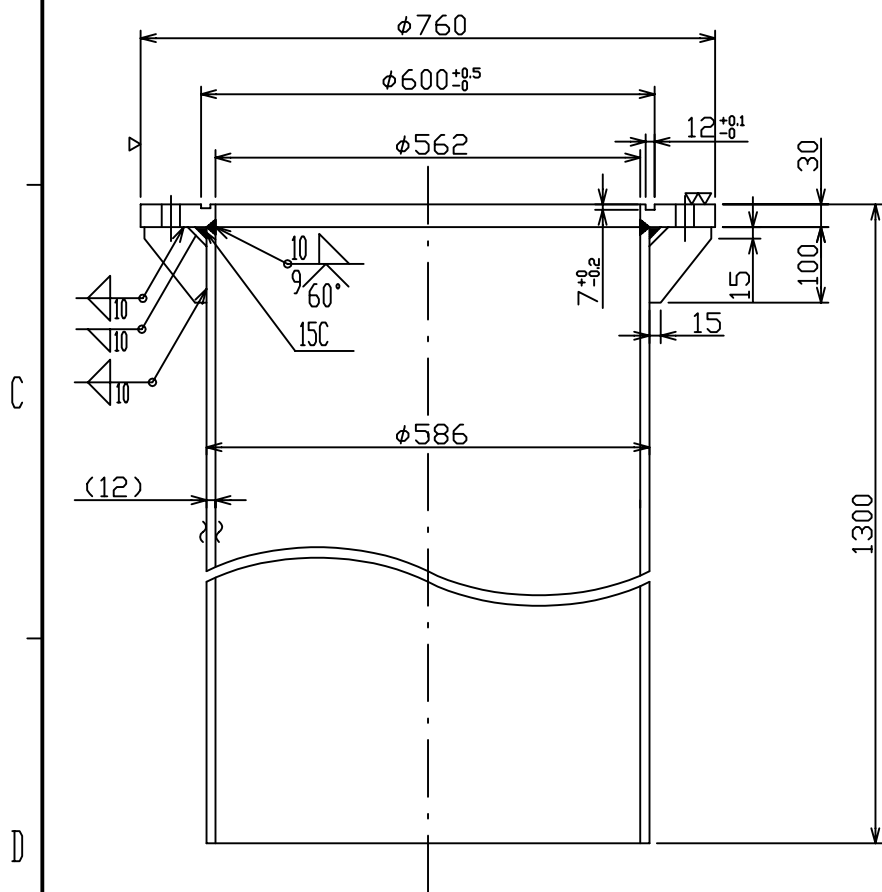
 Oリング溝の仕上げ図
 FINISHING OF O-RING GROOVE
 (尺度 SCALE 1/1)

 A-A' 断面図
 SECTION A-A'

DRAWN Aug. 22 '03 H.MAKI		TITLE 10-077-5501
CHECKED Takahashi T.		名称 格納タンク
APPROVED Y. Hatai	FSV-24/30	外寸図
SCALE 1/10	MASS 260 ±10% kg	NAME RETRACTION TANK
DWG.No. C1318-G16-B	10-077-5501-0	OUTLINE DRAWING

2 3 4 5 6

INSTALLATION METHOD OF RETRDUCTION TANK

1. Install tank to hull plate with fillet welding taking the following points into account;
 - * Flange face is exactly horizontal at normal ship's trim.
 - * One of 24 bolt holes on flange is faced dead ahead.
 - * Allow height of flange face from keel bottom "Ht" mentioned in the drawings, otherwise transducer beam is blocked by the keel, when transducer is fully lowered.
 - * Tank's length "Lt" should be less than "Ht". If not so, bottom end of tank is placed below keel level. "Lt" is also limited as shown in the drawings so that the transducer can be fully retracted in tank. (The tank is supplied with 1300mm long as standard.
2. Fit doubling plate ⑦ of outer dia. $\phi 1300$ around the tank on hull plate.
3. Fit fairing plate ⑧ referring to the drawing "D" for installation method A and B. Use same material and thickness of doubling and fairing plate as hull plate.
4. Allow clearance of more than 250 mm below the flange face for easy bolting. Sink the inner hull plate as shown in the drawing B for high inner hull plate.

整備手順

1. 次の点に注意して、格納タンクを船底板に連続スミ肉溶接する。
 - * タンクのフランジ面が離岸走航時に水平になること。
 - * フランジ面のボルト穴の中心が船首方向になること。
 - * 送受波器を突出させたときに送受波ビームがキールで遮られないように、フランジ面のキールより下の高さ "Ht" を図示の範囲内にすること。
 - * タンク下端がキールより下に出ないようタンク長さ "Lt" は、"Ht" より短くする。かつ、送受波器がタンク下端より出ないように図示の範囲内にすること (標準支給長さ1300mm)
2. 格納タンクの周囲に外径 $\phi 1300$ 以上のダブラリング⑦を取付ける。また、突出装置 (A・B図) の場合には、整流覆⑧ (D図) を取付ける。ダブラリングと整流覆には、船底板と同じ材質・肉厚のものを使用すること。
3. タンク周囲と隔壁⑤を溶接する。
4. 上下装置本体を格納タンクにボルト締めするのに必要なスペースとしてフランジ面の位置を二重船底板より250mm以上離す。二重船底が高い場合にはB図の方法で二重船底板を下げ、スペースを確保すること。

A. キール上 (突出) ON KEEL (PROJECTED)

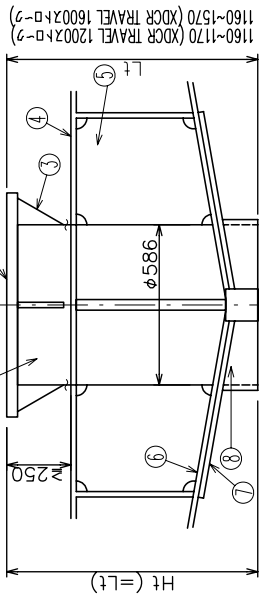

B. キール横 (突出) OFF KEEL (PROJECTED)

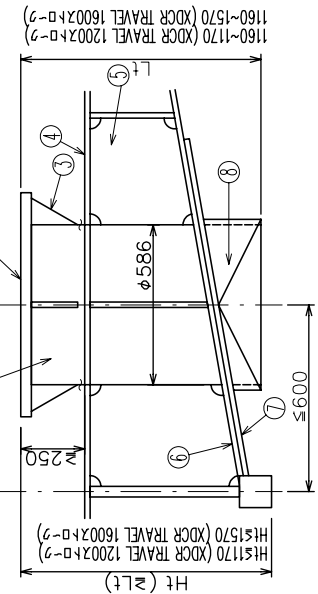

C. キール横 (非突出) OFF KEEL (NOT PROJECTED)

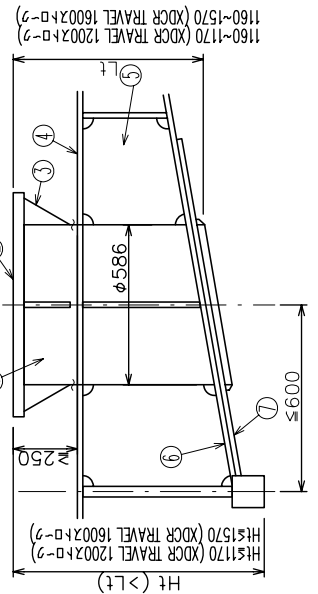

D. 整流覆 FAIRING PLATE

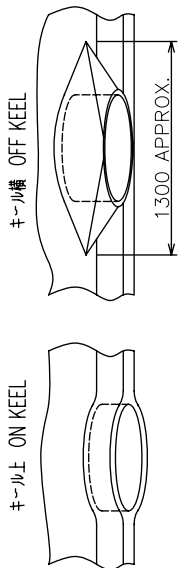

品番 ITEM NO.	品名 NAME	材種 MATERIAL	数量 QTY	単位 UNIT	備考 REMARKS
8	整流覆 FAIRING PLATE				
7	ダブラリング DOUBLING				
6	船底板 HULL PLATE				
5	油槽隔壁 BULKHEAD				
4	二重船底板 INNER HULL PLATE				
3	補強リブ REINFORCEMENT RIB				
2	タンクフランジ TANK FLANGE				
1	格納タンク RETRDUCTION TANK				

DRAWN	Seq. 02_03	H. MAKI	TITLE	FSV-24/24S/30/30S
CHECKED		Takahashi T.	名称	格納タンク (鋼船用)
APPROVED		Y. Hatai	FSV-24/24S/30/30S	整備要領
SCALE		MASS	NAME	RETRDUCTION TANK (FOR STEEL HULL)
DWG No.	C1318-Y01-C	kg		INSTALLATION PROCEDURE

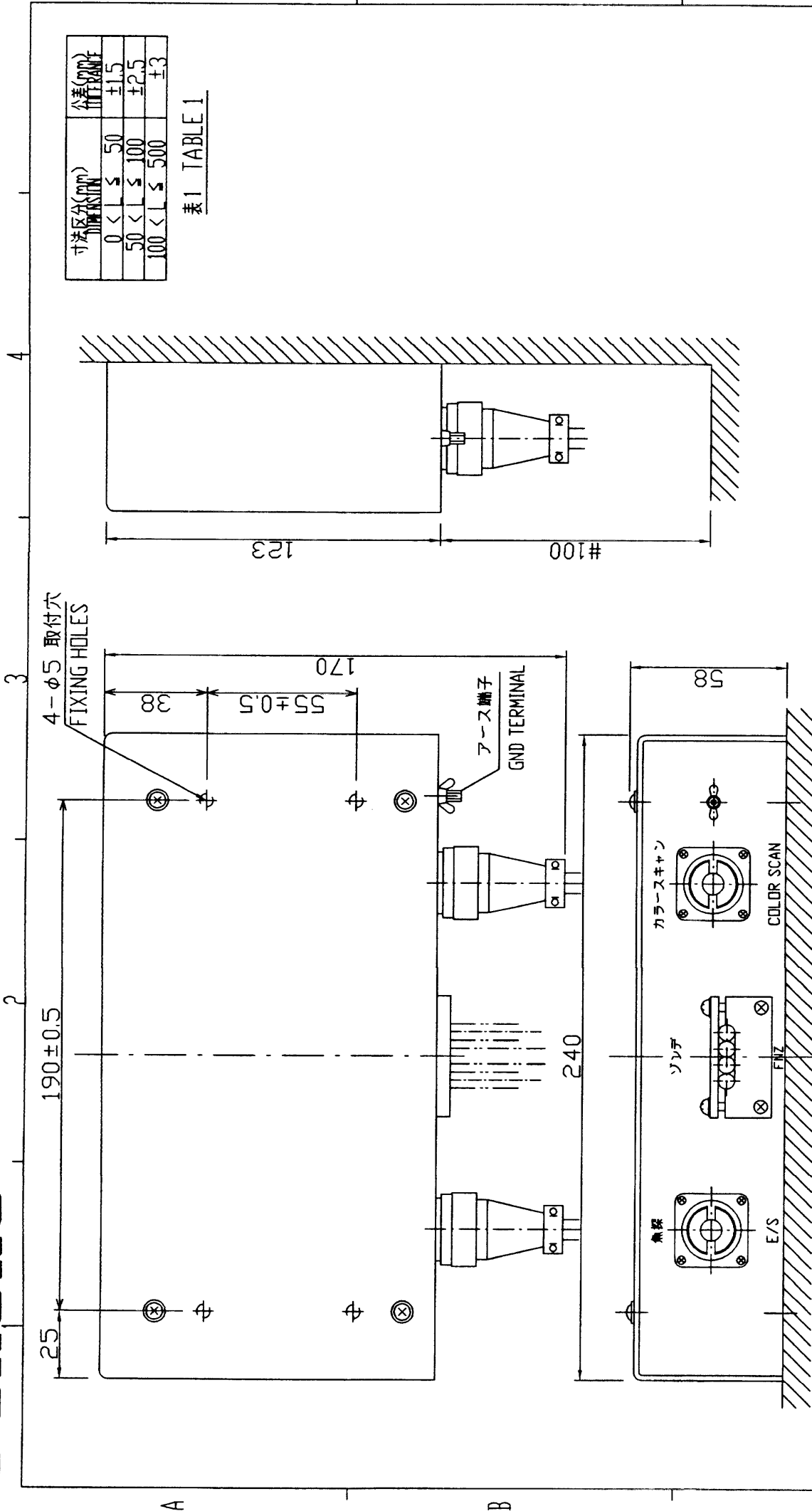

寸法区分 (DIMENSION)	公差 (TOLERANCE)
$0 < L \leq 50$	± 1.5
$50 < L \leq 100$	± 2.5
$100 < L \leq 500$	± 3

表1 TABLE 1

DRAWN JUL. 11 '01 I. YAMASAKI	TITLE CS-170
CHECKED Y. K. I.	名称 ネットゾンデ接続箱
APPROVED Y. K. I.	外寸図
SCALE 1/2 MASS 2 $\pm 10\%$ kg	NAME NET JOINT BOX
DWG.No. C1233-007-D	OUTLINE DRAWING

注記
 1) # : 推奨する最小サービス空間寸法。
 2) # : 指定なき寸法公差は表1による。

NOTE
 1. # : RECOMMENDED SERVICE CLEARANCE.
 2. TABLE 1 INDICATES TOLERANCE OF DIMENSIONS.

表1 TABLE 1

寸法区分(mm) DIMENSIONS	公差(mm) TOLERANCE
0 < L ≤ 50	±1.5
50 < L ≤ 100	±2.5
100 < L ≤ 500	±3

A

B

C

D

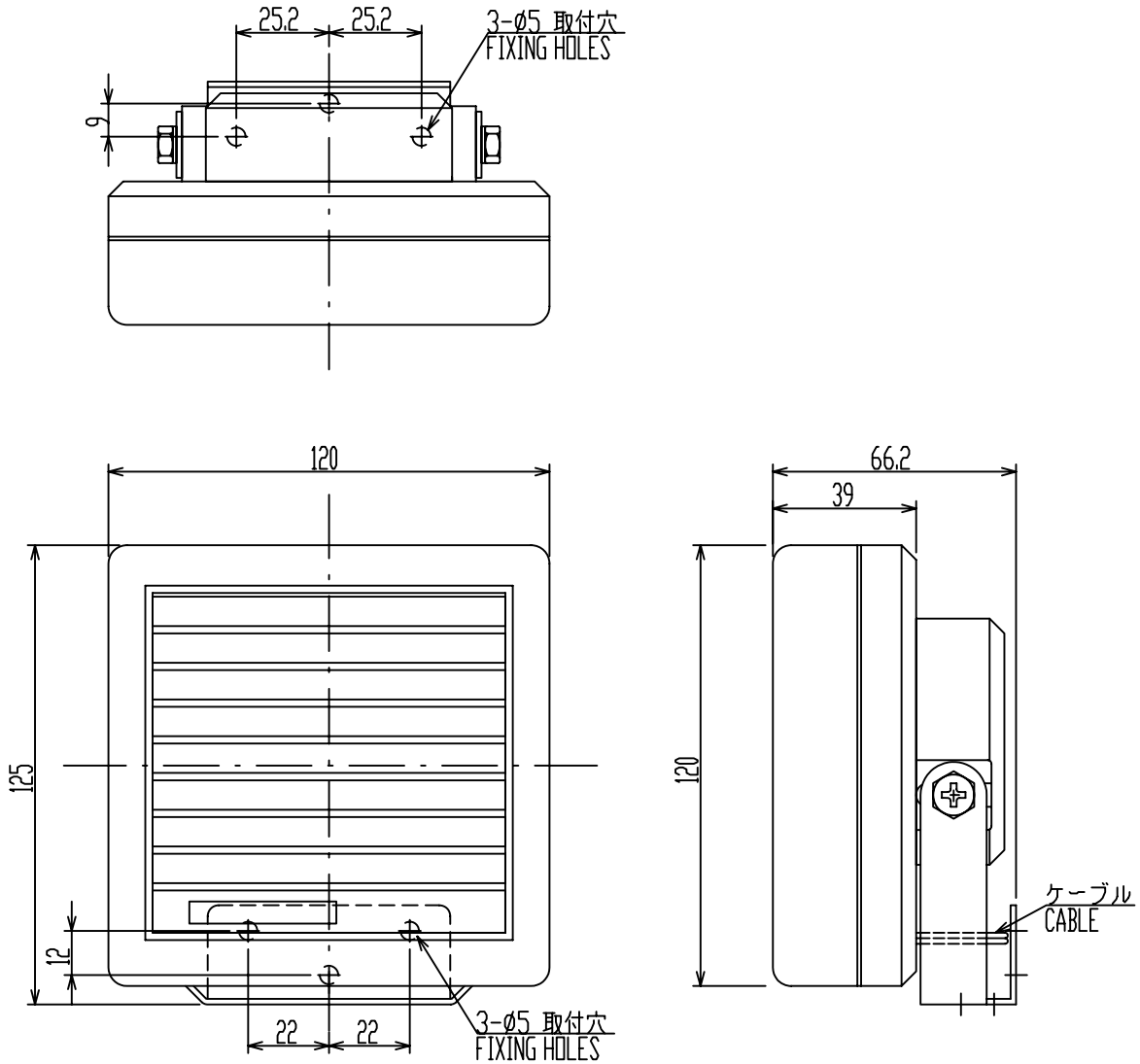

注記 1) 指定外寸法公差は表1による。

NOTE 1. TABLE 1 INDICATES TOLERANCE OF DIMENSIONS WHICH IS NOT SPECIFIED.

DRAWN	Nov. 25, '06	E. MIYOSHI	TITLE	SEM-21Q
CHECKED		TAKAHASHI, T	名称	スピーカ
APPROVED		Y. Hatai		外寸図
SCALE	1/2	MASS 0.54 ±10% kg	質量は2.8mケーブルを含む MASS W/ 2.8m CABLE	NAME
DWG.No.	C5016-G07-C		REF.No.	LOUDSPEAKER
				OUTLINE DRAWING

寸法区分 (mm) DIMENSION	公差 (mm) TOLERANCE
$L \leq 50$	± 1.5
$50 < L \leq 100$	± 2.5
$100 < L \leq 500$	± 3
$500 < L \leq 1000$	± 4

表 1 TABLE 1

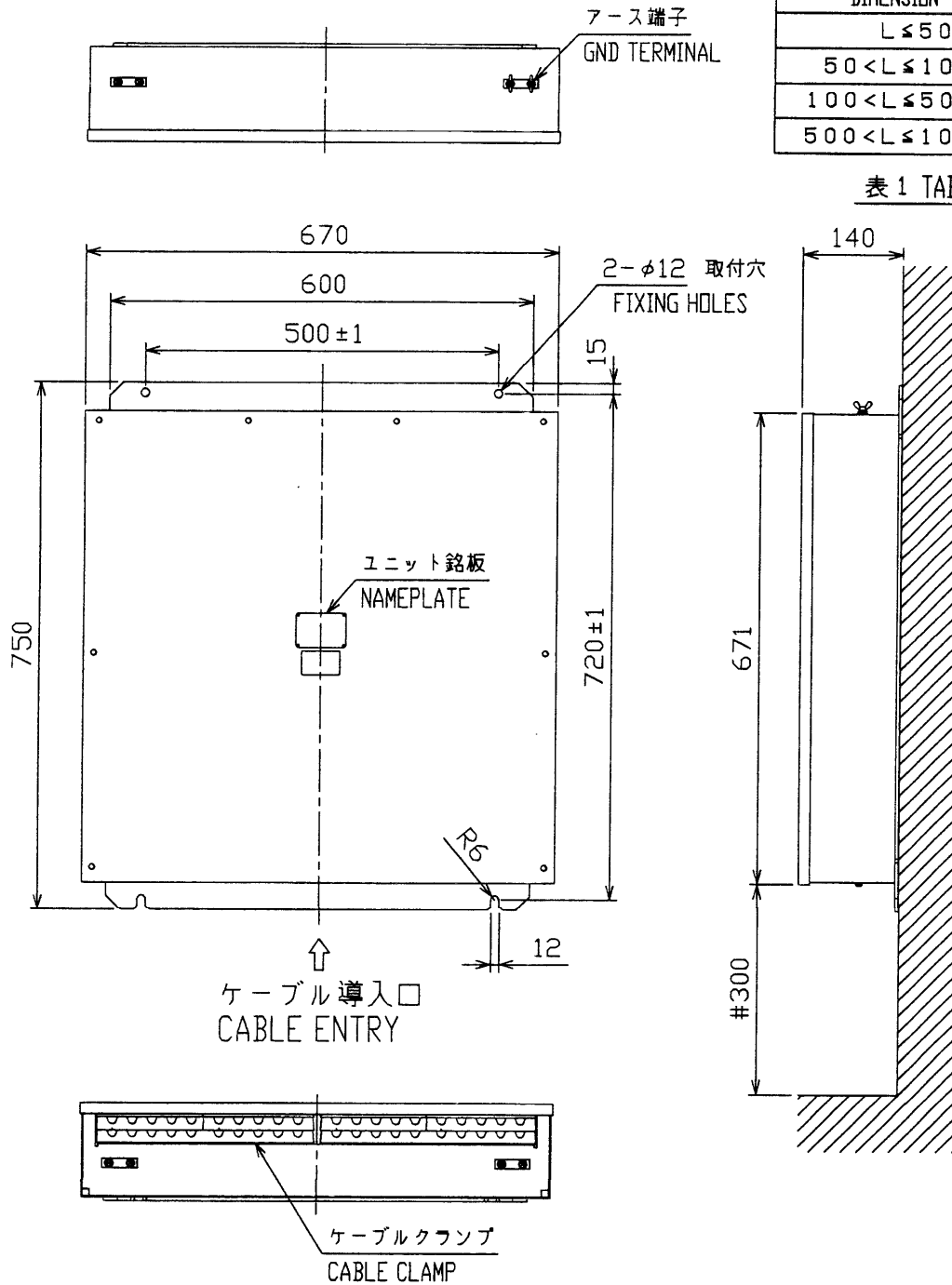

- 注 記 1) #印寸法は最小サービス空間寸法とする。
 2) 指定外の寸法公差は表 1 による。
 3) 取付は M10 ボルトを使用のこと。
 4) アース端子は 4カ所のうち 1カ所を選択して、使用のこと。

- NOTE 1. #: RECOMMENDED SERVICE CLEARANCE.
 2. TABLE 1 INDICATES TOLERANCE OF DIMENSIONS.
 3. USE M10 BOLTS FOR FIXING THE UNIT.
 4. SELECT ONE GROUND TERMINAL AMONG FOUR.

DRAWN Jan. 17 '02 T. YAMASAKI		TITLE FSV-245
CHECKED Jan 18 '02 Y. Kimi		名称 接続箱
APPROVED Jan 18, 02 S. Fujimori	FSV-24/24S	外寸図
SCALE 1/10	MASS 23 ±10% kg	NAME JUNCTION BOX
DWG. No. C1318-G10-A	10-071-700G-2	OUTLINE DRAWING

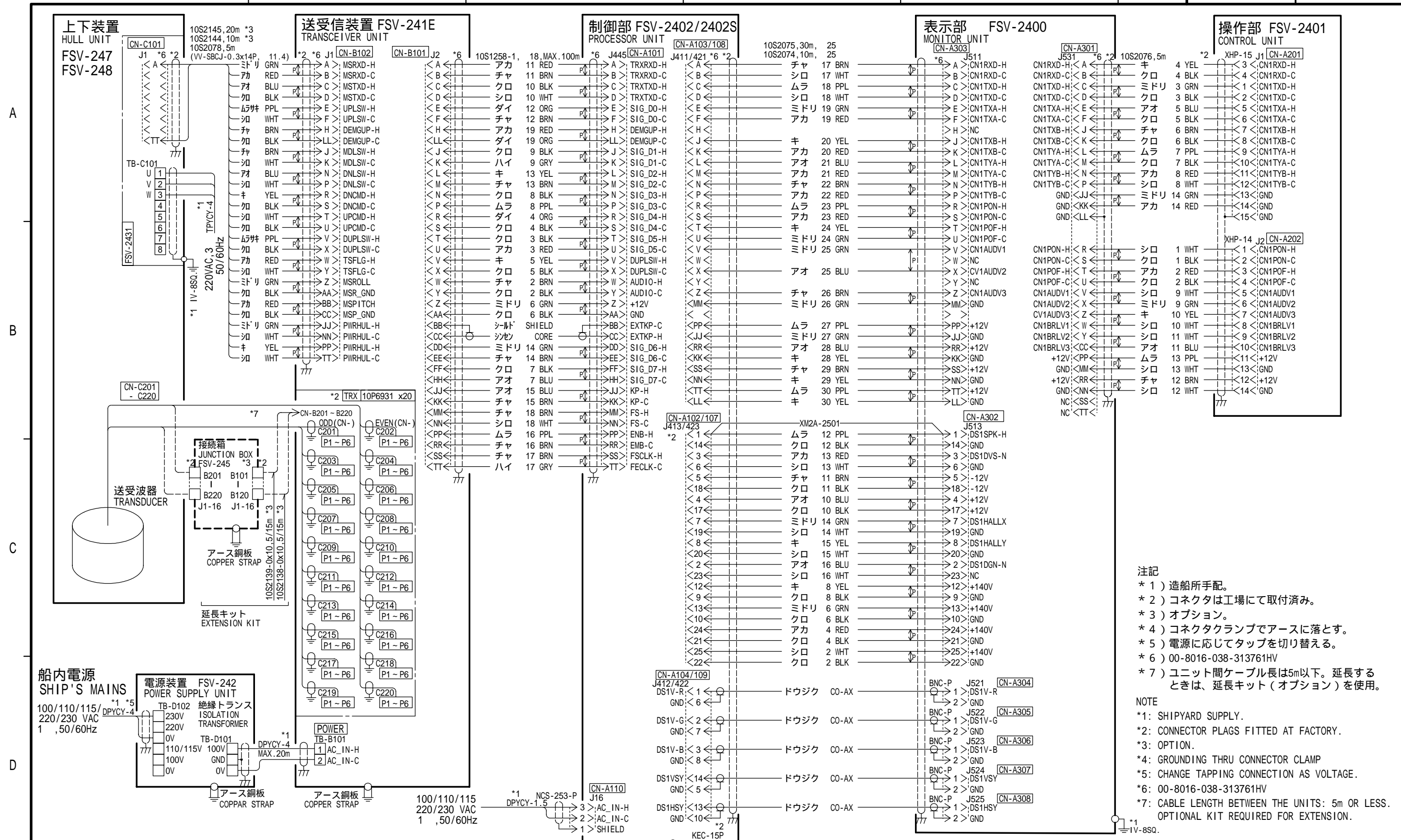

- 注記
- * 1) 造船所手配。
 - * 2) コネクタは工場にて取付済み。
 - * 3) オプション。
 - * 4) コネクタランプでアースに落とす。
 - * 5) 電源に応じてタップを切り替える。
 - * 6) 00-8016-038-313761HV
 - * 7) ユニット間ケーブル長は5m以下。延長するときは、延長キット (オプション) を使用。

- NOTE
- *1: SHIPYARD SUPPLY.
 - *2: CONNECTOR PLAGS FITTED AT FACTORY.
 - *3: OPTION.
 - *4: GROUNDING THRU CONNECTOR CLAMP
 - *5: CHANGE TAPPING CONNECTION AS VOLTAGE.
 - *6: 00-8016-038-313761HV
 - *7: CABLE LENGTH BETWEEN THE UNITS: 5m OR LESS. OPTIONAL KIT REQUIRED FOR EXTENSION.

DRAWN Jan. 28 '03 T. YAMASAKI	TITLE FSV-24/24S
CHECKED Jan. 28 '03 Y. KIMURA	名称 カラスキャニングソナー
APPROVED Jan. 28, '03 <i>Y. Kimura</i>	相互結線図
SCALE MASS kg	NAME COLOR SCANNING SONAR
DWG No. C1318-C07- A	10-071-0103-0 INTERCONNECTION DIAGRAM

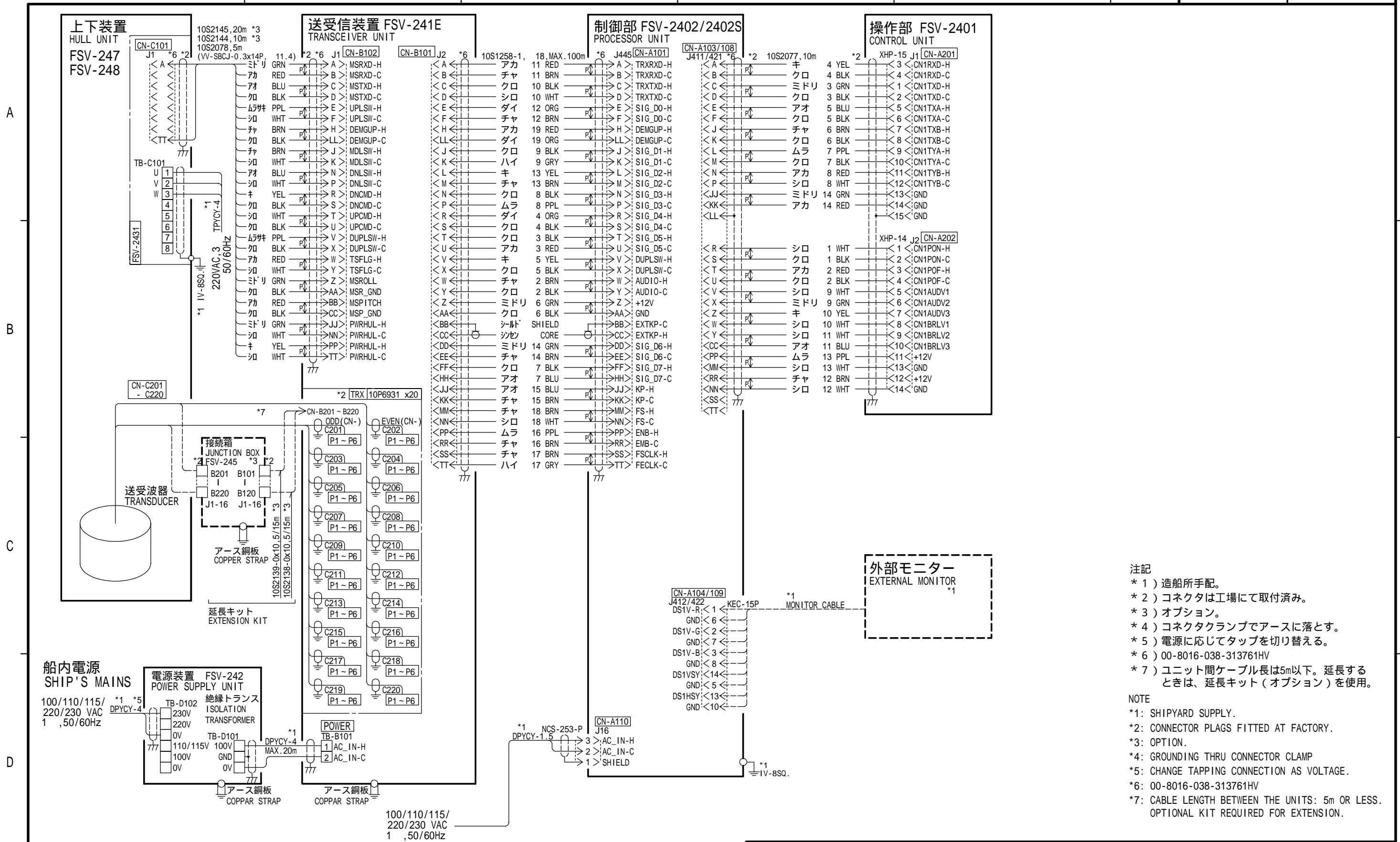

- 注記
- *1) 造船所手配。
 - *2) コネクタは工場にて取付済み。
 - *3) オプション。
 - *4) コネクタランプでアースに落とす。
 - *5) 電源に応じてタップを切り替える。
 - *6) 00-8016-038-313761HV
 - *7) ユニット間ケーブル長は5m以下。延長するときは、延長キット(オプション)を使用。
- NOTE
- *1: SHIPYARD SUPPLY.
 - *2: CONNECTOR PLAGS FITTED AT FACTORY.
 - *3: OPTION.
 - *4: GROUNDING THRU CONNECTOR CLAMP
 - *5: CHANGE TAPPING CONNECTION AS VOLTAGE.
 - *6: 00-8016-038-313761HV
 - *7: CABLE LENGTH BETWEEN THE UNITS: 5m OR LESS. OPTIONAL KIT REQUIRED FOR EXTENSION.

DRAWN Jan. 28 '03 T. YAMASAKI	TITLE FSV-24/24S
CHECKED Jan. 28 '03 Y. KIMURA	名称 カラスキャニングソナー
APPROVED Jan. 28, '03 <i>Y. Kimura</i>	相互結線図
SCALE MASS kg	NAME COLOR SCANNING SONAR
DWG No. C1318-C08- A	10-071-0103-0 INTERCONNECTION DIAGRAM

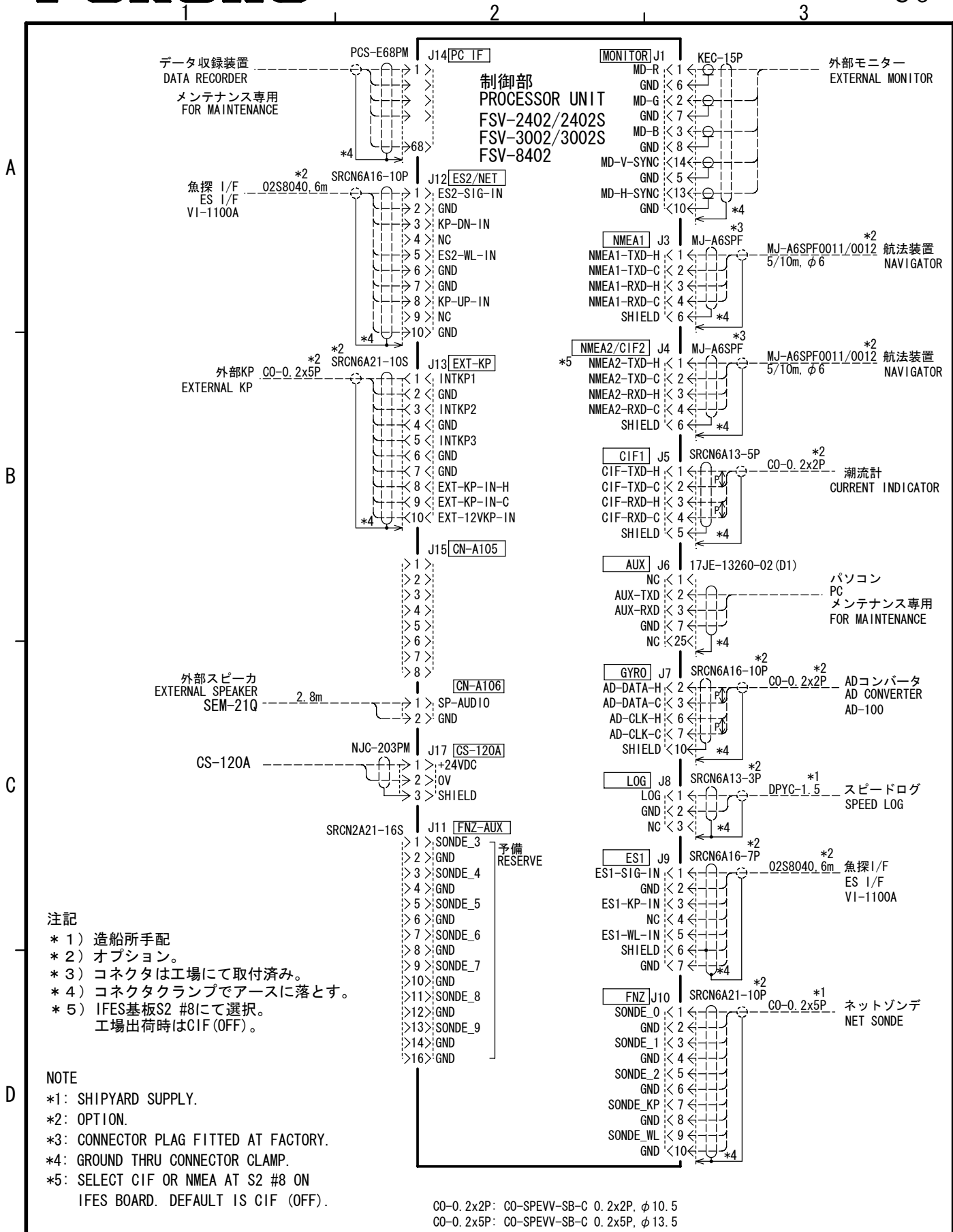

DRAWN Dec. 26 '06 E. MIYOSI	TITLE FSV-2402/2402S/3002/3002S/8402
CHECKED TAKAHASHI. T	名称 制御部外部信号接続
APPROVED Y. Hatai	FSV-24/24S/30/30S/84/84L 相互結線図
SCALE MASS kg	NAME PROCESSOR UNIT EXTERNAL INTERFACE
DWG. No. C1318-C03- N	INTERCONNECTION DIAGRAM

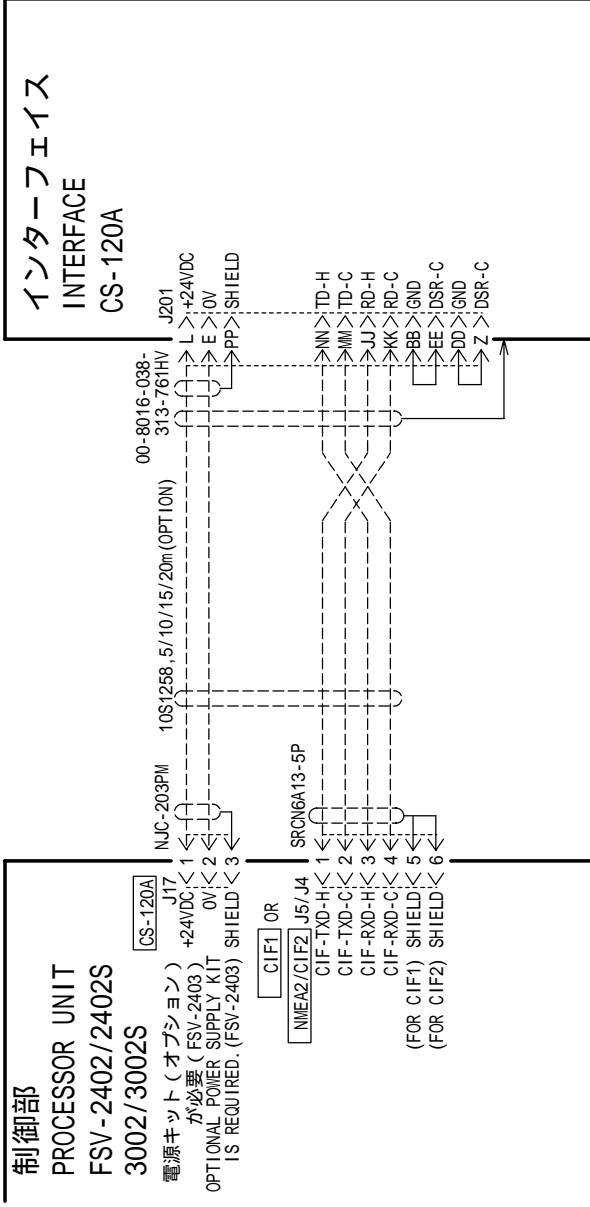

DRAWN		TITLE	CS-120A
CHECKED	Sep. 02 '03 H. MAKI Takahashi T.	名称	インターフェイス
APPROVED	Y. Hatai	相互結線図	
SCALE	MASS kg	INTERFACE	
DWG. No.	C1318-C06-C	INTERCONNECTION DIAGRAM	