

Version 1.0

Published April 2013

Copyright©2013 ASRock INC. All rights reserved.



Copyright Notice:

No part of this documentation may be reproduced, transcribed, transmitted, or translated in any language, in any form or by any means, except duplication of documentation by the purchaser for backup purpose, without written consent of ASRock Inc.

Products and corporate names appearing in this documentation may or may not be registered trademarks or copyrights of their respective companies, and are used only for identification or explanation and to the owners' benefit, without intent to infringe.

Disclaimer:

Specifications and information contained in this documentation are furnished for informational use only and subject to change without notice, and should not be construed as a commitment by ASRock. ASRock assumes no responsibility for any errors or omissions that may appear in this documentation.

With respect to the contents of this documentation, ASRock does not provide warranty of any kind, either expressed or implied, including but not limited to the implied warranties or conditions of merchantability or fitness for a particular purpose.

In no event shall ASRock, its directors, officers, employees, or agents be liable for any indirect, special, incidental, or consequential damages (including damages for loss of profits, loss of business, loss of data, interruption of business and the like), even if ASRock has been advised of the possibility of such damages arising from any defect or error in the documentation or product.

The terms HDMI™ and HDMI High-Definition Multimedia Interface, and the HDMI logo are trademarks or registered trademarks of HDMI Licensing LLC in the United States and other countries.



This device complies with Part 15 of the FCC Rules. Operation is subject to the following two conditions:

- (1) this device may not cause harmful interference, and
- (2) this device must accept any interference received, including interference that may cause undesired operation.

CALIFORNIA, USA ONLY

The Lithium battery adopted on this motherboard contains Perchlorate, a toxic substance controlled in Perchlorate Best Management Practices (BMP) regulations passed by the California Legislature. When you discard the Lithium battery in California, USA, please follow the related regulations in advance.

“Perchlorate Material-special handling may apply, see www.dtsc.ca.gov/hazardouswaste/perchlorate”

ASRock Website: <http://www.asrock.com>

Manufactured under license under U.S. Patent Nos: 5,956,674; 5,974,380; 6,487,535; 7,003,467 & other U.S. and worldwide patents issued & pending. DTS, the Symbol, & DTS and the Symbol together is a registered trademark & DTS Connect, DTS Interactive, DTS Neo:PC are trademarks of DTS, Inc. Product includes software.

© DTS, Inc., All Rights Reserved.



Motherboard Layout

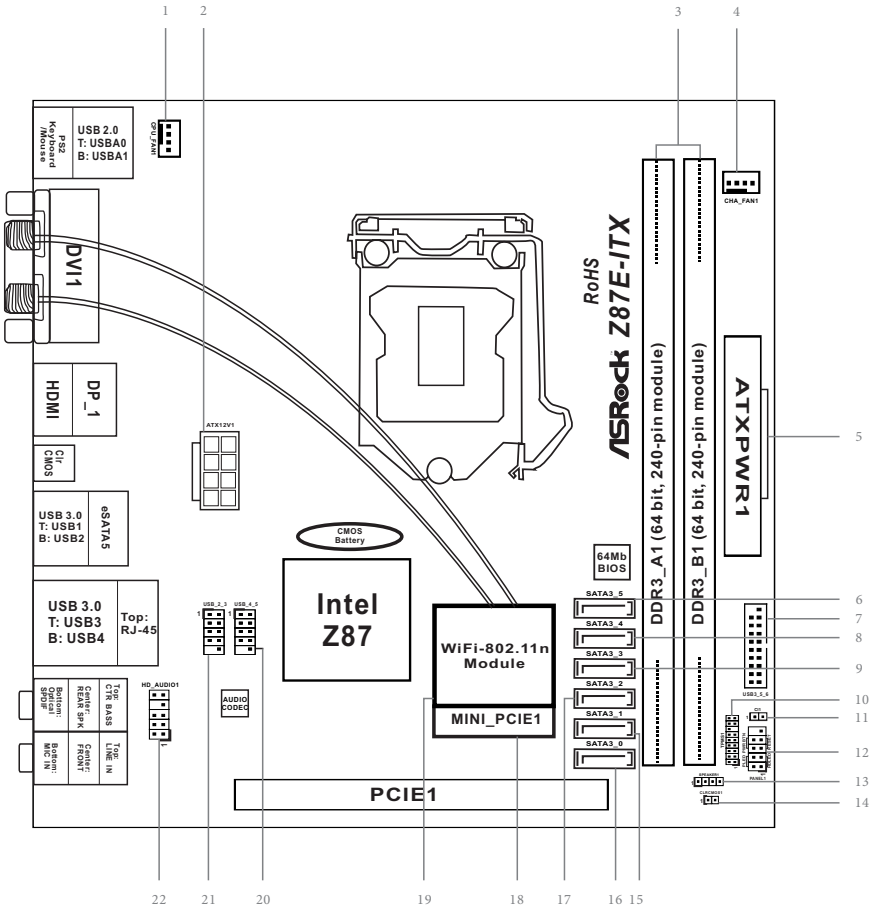

23

mSATA/mini-PCle

No.	Description
1	CPU Fan Connector (CPU_FAN1)
2	ATX 12V Power Connector (ATX12V1)
3	2 x 240-pin DDR3 DIMM Slots (DDR3_A1, DDR3_B1)
4	Chassis Fan Connector (CHA_FAN1)
5	ATX Power Connector (ATXPWR1)
6	SATA3 Connector (SATA3_5) (shared with eSATA)
7	USB 3.0 Header (USB3_5_6)
8	SATA3 Connector (SATA3_4) (shared with mSATA)
9	SATA3 Connector (SATA3_3)
10	TPM Header (TPMS1)
11	Chassis Intrusion Header (CII)
12	System Panel Header (PANEL1)
13	Chassis Speaker Header (SPEAKER1)
14	Clear CMOS Jumper (CLRCMOS1)
15	SATA3 Connector (SATA3_1)
16	SATA3 Connector (SATA3_0)
17	SATA3 Connector (SATA3_2)
18	mini-PCI Express Slot (MINI_PCIE1)
19	WiFi-802.11n Module
20	USB 2.0 Header (USB_4_5)
21	USB 2.0 Header (USB_2_3)
22	Front Panel Audio Header (HD_AUDIO1)
23	mSATA Connector (MINI_PCIE2)

I/O Panel

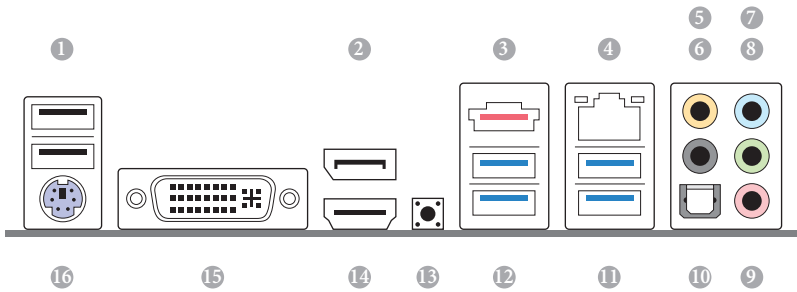

No.	Description	No.	Description
1	USB 2.0 Ports (USB01)	9	Microphone (Pink)
2	Display Port	10	Optical SPDIF Out Port
3	eSATA Connector***	11	USB 3.0 Ports (USB3_34)
4	LAN RJ-45 Port	12	USB 3.0 Ports (USB3_12)
5	Central / Bass (Orange)	13	Clear CMOS Switch
6	Rear Speaker (Black)	14	HDMI Port
7	Line In (Light Blue)	15	DVI-I Port
8	Front Speaker (Lime)**	16	PS/2 Keyboard/Mouse Port

* There are two LEDs on each LAN port. Please refer to the table below for the LAN port LED indications.

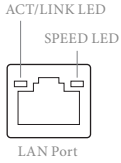

Activity / Link LED		Speed LED	
Status	Description	Status	Description
Off	No Link	Off	10Mbps connection
Blinking	Data Activity	Orange	100Mbps connection
On	Link	Green	1Gbps connection

** If you use a 2-channel speaker, please connect the speaker's plug into "Front Speaker Jack". See the table below for connection details in accordance with the type of speaker you use.

Audio Output Channels	Front Speaker (No. 8)	Rear Speaker (No. 6)	Central / Bass (No. 5)	Line In (No. 7)
2	V	--	--	--
4	V	V	--	--
6	V	V	V	--
8	V	V	V	V



To enable Multi-Streaming, you need to connect a front panel audio cable to the front panel audio header. After restarting your computer, you will find the "Mixer" tool on your system. Please select "Mixer Toolbox" , click "Enable playback multi-streaming", and click "ok". Choose "2CH", "4CH", "6CH", or "8CH" and then you are allowed to select "Realtek HDA Primary output" to use the Rear Speaker, Central/Bass, and Front Speaker, or select "Realtek HDA Audio 2nd output" to use the front panel audio.

*** The eSATA connector is shared with SATA3_5 connector.

Chapter 1 Introduction

Thank you for purchasing ASRock Z87E-ITX motherboard, a reliable motherboard produced under ASRock's consistently stringent quality control. It delivers excellent performance with robust design conforming to ASRock's commitment to quality and endurance.

In this manual, Chapter 1 and 2 contains the introduction of the motherboard and step-by-step installation guides. Chapter 3 contains the operation guide of the software and utilities. Chapter 4 contains the configuration guide of the BIOS setup.



Because the motherboard specifications and the BIOS software might be updated, the content of this documentation will be subject to change without notice. In case any modifications of this manual occur, the updated version will be available on ASRock's website without further notice. If you require technical support related to this motherboard, please visit our website for specific information about the model you are using. You may find the latest VGA cards and CPU support list on ASRock's website as well. ASRock website <http://www.asrock.com>.

1.1 Package Contents

- ASRock Z87E-ITX Motherboard (Mini-ITX Form Factor)
- ASRock Z87E-ITX Quick Installation Guide
- ASRock Z87E-ITX Support CD
- 4 x Serial ATA (SATA) Data Cables (Optional)
- 1 x I/O Panel Shield
- 1 x ASRock WiFi 2.4/5GHz Antenna
- 1 x DVI-to-D-Sub Converter

1.2 Specifications

Platform	<ul style="list-style-type: none"> • Mini-ITX Form Factor • Premium Gold Capacitor design (100% Japan-made high-quality Conductive Polymer Capacitors)
A-Style	<ul style="list-style-type: none"> • Home Cloud • WiFi 802.11ac
CPU	<ul style="list-style-type: none"> • Supports 4th Generation Intel® Core™ i7 / i5 / i3 / Xeon® / Pentium® / Celeron® in LGA1150 Package • Digi Power Design • 6 Power Phase Design • DrMOS • Supports Intel® Turbo Boost 2.0 Technology • Supports Intel® K-Series unlocked CPU • Supports ASRock BCLK Full-range Overclocking
Chipset	<ul style="list-style-type: none"> • Intel® Z87
Memory	<ul style="list-style-type: none"> • Dual Channel DDR3 Memory Technology • 2 x DDR3 DIMM slots • Supports DDR3 2933+(OC)/2800(OC)/2400(OC)/2133(OC)/1866(OC)/1600/1333/1066 non-ECC, un-buffered memory • Max. capacity of system memory: 16GB (see CAUTION) • Supports Intel® Extreme Memory Profile (XMP)1.3/1.2
Expansion Slot	<ul style="list-style-type: none"> • 1 x PCI Express 3.0 x16 slot • 1 x half mini-PCI Express slot: For WiFi + BT module • 1 x mSATA/full mini-PCI Express slot
Graphics	<ul style="list-style-type: none"> • Intel® HD Graphics Built-in Visuals and the VGA outputs can be supported only with processors which are GPU integrated. • Supports Intel® HD Graphics Built-in Visuals : Intel® Quick Sync Video with AVC, MVC (S3D) and MPEG-2 Full HW Encode1, Intel® InTru™ 3D, Intel® Clear Video HD Technology, Intel® Insider™, Intel® HD Graphics 4400/4600 • Pixel Shader 5.0, DirectX 11.1 • Max. shared memory 1792MB

- Three VGA Output options: DVI-I, HDMI and DisplayPort
- Supports Triple Monitors
- Supports HDMI Technology with max. resolution up to 4K × 2K (4096x2304) @ 24Hz
- Supports DVI-I with max. resolution up to 1920x1200 @ 60Hz
- Supports DisplayPort with max. resolution up to 3840x2160 @ 60Hz
- Supports Auto Lip Sync, Deep Color (12bpc), xvYCC and HBR (High Bit Rate Audio) with HDMI (Compliant HDMI monitor is required)
- Supports HDCP function with DVI-I, HDMI and DisplayPort ports
- Supports Full HD 1080p Blu-ray (BD) / HD-DVD playback with DVI-I, HDMI and DisplayPort ports

Audio

- 7.1 CH HD Audio with Content Protection (Realtek ALC1150 Audio Codec)
- Premium Blu-ray audio support
- TI® NE5532 Premium Headset Amplifier (supports up to 600 Ohms headsets)
- Supports DTS Connect

LAN

- Gigabit LAN 10/100/1000 Mb/s
- Giga PHY Intel® I217V
- Supports Intel® Remote Wake Technology
- Supports Wake-On-LAN
- Supports Energy Efficient Ethernet 802.3az
- Supports PXE

Wireless LAN

- Supports IEEE 802.11a/b/g/n/ac
- Supports Dual-Band (2.4/5 GHz)
- Supports High speed wireless connection up to 867Mbps
- 2 antennas to support 2 (Transmit) x 2 (Receive) diversity technology
- Supports Bluetooth 4.0 / 3.0 + High speed class II

Rear Panel I/O

- 1 x PS/2 Mouse/Keyboard Port
- 1 x DVI-I Port
- 1 x HDMI Port
- 1 x DisplayPort
- 1 x Optical SPDIF Out Port
- 1 x eSATA Connector
- 2 x USB 2.0 Ports
- 4 x USB 3.0 Ports
- 1 x RJ-45 LAN Port with LED (ACT/LINK LED and SPEED LED)
- 1 x Clear CMOS Switch
- HD Audio Jack: Rear Speaker / Central / Bass / Line in / Front Speaker / Microphone

Storage

- 6 x SATA3 6.0 Gb/s connectors, support RAID (RAID 0, RAID 1, RAID 5, RAID 10, Intel Rapid Storage Technology 12 and Intel Smart Response Technology), NCQ, AHCI and “Hot Plug” (SATA3_5 connector is shared with the eSATA port; SATA3_4 connector is shared with the mSATA/mini-PCI Express slot)
- 1 x eSATA connector, supports NCQ, AHCI and “Hot Plug” functions
- 1 x mSATA 6.0 Gb/s connector (Solid-State Drive connector), supports NCQ, AHCI functions and Full-size mini-PCI Express modules

Connector

- 1 x Chassis Intrusion header
- 1 x TPM header
- 1 x CPU Fan connector (4-pin)
- 1 x Chassis Fan connector (4-pin)
- 1 x 24 pin ATX power connector
- 1 x 8 pin 12V power connector (High Density Power Connector)
- 1 x Front panel audio connector
- 2 x USB 2.0 headers (support 4 USB 2.0 ports)
- 1 x USB 3.0 header (supports 2 USB 3.0 ports)

**BIOS
Feature**

- 64Mb AMI UEFI Legal BIOS with Multilingual GUI support
- ACPI 1.1 Compliance Wake Up Events
- SMBIOS 2.3.1 Support
- CPU, DRAM, PCH 1.05V, PCH 1.5V Voltage Multi-adjustment

**Support
CD**

- Drivers, Utilities, AntiVirus Software (Trial Version), CyberLink MediaEspresso 6.5 Trial, Google Chrome Browser and Toolbar, Start8, MeshCentral, Splashtop Streamer, Intel®
- Extreme Tuning Utility (XTU)

**Hardware
Monitor**

- CPU/Chassis Temperature Sensing
- CPU/Chassis Tachometer
- CPU/Chassis Quiet Fan (Allow Chassis Fan Speed Auto-Adjust by CPU Temperature)
- CPU/Chassis Fan Multi-Speed Control
- Voltage Monitoring: +12V, +5V, +3.3V, CPU Vcore

OS

- Microsoft® Windows® 8 / 8 64-bit / 7 / 7 64-bit compliant

**Certifica-
tions**

- FCC, CE, WHQL
- ErP/EuP Ready (ErP/EuP ready power supply is required)

* For detailed product information, please visit our website: <http://www.asrock.com>



Please realize that there is a certain risk involved with overclocking, including adjusting the setting in the BIOS, applying Untied Overclocking Technology, or using third-party overclocking tools. Overclocking may affect your system's stability, or even cause damage to the components and devices of your system. It should be done at your own risk and expense. We are not responsible for possible damage caused by overclocking.



Due to limitation, the actual memory size may be less than 4GB for the reservation for system usage under Windows® 32-bit operating systems. Windows® 64-bit operating systems do not have such limitations. You can use ASRock XFast RAM to utilize the memory that Windows® cannot use.

1.3 Unique Features



ASRock A-Tuning

A-Tuning is ASRock's multi purpose software suite with a new interface, more new features and improved utilities, including XFast RAM, Dehumidifier, Good Night LED, FAN-Tastic Tuning, OC Tweaker and a whole lot more.



ASRock Instant Flash

ASRock Instant Flash is a BIOS flash utility embedded in Flash ROM. This convenient BIOS update tool allows you to update the system BIOS in a few clicks without preparing an additional floppy diskette or other complicated flash utility. Just save the new BIOS file to your USB storage and launch this tool by pressing <F6> or <F2> during POST to enter the BIOS setup menu to access ASRock Instant Flash. Please be noted that the USB flash drive or hard drive must use FAT32/16/12 file system.



ASRock APP Charger

Simply by installing the ASRock APP Charger makes your iPhone/iPad/iPod Touch charge up to 40% faster than before on your computer. ASRock APP Charger allows you to quickly charge many Apple devices simultaneously and even supports continuous charging when your PC enters into Standby mode (S1), Suspend to RAM (S3), hibernation mode (S4) or power off (S5).



ASRock XFast USB

ASRock XFast USB can boost the performance of your USB storage devices. The performance may depend on the properties of the device.



ASRock XFast LAN

ASRock XFast LAN provides faster internet access, which includes the benefits listed below. LAN Application Prioritization: You can configure your application's priority ideally and add new programs to the list. Lower Latency in Game: After setting online game's priority higher, it can lower the latency in games. Traffic Shaping: You can watch Youtube HD videos and download simultaneously. Real-Time Analysis of Your Data: With the status window, you can easily recognize which data streams you are currently transferring.



ASRock XFast RAM

ASRock XFast RAM is included in A-Tuning. It fully utilizes the memory space that cannot be used under Windows® 32-bit operating systems. ASRock XFast RAM shortens the loading time of previously visited websites, making web surfing faster than ever. And it also boosts the speed of Adobe Photoshop 5 times faster. Another advantage of ASRock XFast RAM is that it reduces the frequency of accessing your SSDs or HDDs in order to extend their lifespan.



ASRock Crashless BIOS

ASRock Crashless BIOS allows users to update their BIOS without fear of failing. If power loss occurs during the BIOS updating process, ASRock Crashless BIOS will automatically finish the BIOS update procedure after regaining power. Please note that BIOS files need to be placed in the root directory of your USB disk. Only USB 2.0 ports support this feature.



ASRock OMG (Online Management Guard)

Administrators are able to establish an internet curfew or restrict internet access at specified times via OMG. You may schedule the starting and ending hours of internet access granted to other users. In order to prevent users from bypassing OMG, guest accounts without permission to modify the system time are required.



ASRock Internet Flash

ASRock Internet Flash downloads and updates the latest UEFI firmware version from our servers for you without entering Windows® OS. Please setup network configuration before using Internet Flash.



ASRock UEFI System Browser

ASRock System Browser shows the overview of your current PC and the devices connected.



ASRock Dehumidifier Function

Users may prevent motherboard damages due to dampness by enabling “Dehumidifier Function”. When enabling Dehumidifier Function, the computer will power on automatically to dehumidify the system after entering S4/S5 state.



ASRock Easy RAID Installer

ASRock Easy RAID Installer can help you to copy the RAID driver from the support CD to your USB storage device. After copying the RAID driver to your USB storage device, please change “SATA Mode” to “RAID”, then you can start installing the OS in RAID mode.



ASRock Easy Driver Installer

For users that don't have an optical disk drive to install the drivers from our support CD, Easy Driver Installer is a handy tool in the UEFI that installs the LAN driver to your system via an USB storage device, then downloads and installs the other required drivers automatically.



ASRock Interactive UEFI

ASRock Interactive UEFI is a blend of system configuration tools, cool sound effects and stunning visuals. The unprecedented UEFI provides a more attractive interface and more amusement.



ASRock Fast Boot

With ASRock's exclusive Fast Boot technology, it takes less than 1.5 seconds to logon to Windows 8 from a cold boot. No more waiting! The speedy boot will completely change your user experience and behavior.



ASRock Restart to UEFI

Windows® 8 brings the ultimate boot up experience. The lightning boot up speed makes it hard to access the UEFI setup. ASRock Restart to UEFI allows users to enter the UEFI automatically when turning on the PC. By enabling this function, the PC will enter the UEFI directly after you restart.



ASRock Good Night LED

ASRock Good Night LED technology offers you a better sleeping environment by extinguishing the unessential LEDs. By enabling Good Night LED in the BIOS, the Power/HDD LEDs will be switched off when the system is powered on. Good Night LED will automatically switch off the Power and Keyboard LEDs when the system enters into Standby/Hibernation mode as well.



ASRock USB Key

In a world where time is money, why waste precious time everyday typing usernames to log in to Windows? Why should we even bother memorizing those foot long passwords? Just plug in the USB Key and let your computer log in to windows automatically!



ASRock Home Cloud

This motherboard supports remote wake with the onboard Intel LAN, so you can connect with your PC from anywhere in the world. You will be able to power your PC on or turn it off, monitor and take control of it remotely with another smartphone, tablet or computer.



ASRock FAN-Tastic Tuning

ASRock FAN-Tastic Tuning is included in A-Tuning. Configure up to five different fan speeds using the graph. The fans will automatically shift to the next speed level when the assigned temperature is met.

1.4 WiFi-802.11n Module and ASRock WiFi 2.4GHz Antenna

WiFi + BT Module

This motherboard comes with an exclusive WiFi 802.11 a/b/g/n/ac + BT v4.0 module that offers support for WiFi 802.11 a/b/g/n/ac connectivity standards and Bluetooth v4.0. WiFi + BT module is an easy-to-use wireless local area network (WLAN) adapter to support WiFi + BT. Bluetooth v4.0 standard features Smart Ready technology that adds a whole new class of functionality into the mobile devices including Apple's most recent iPhone 4S. BT 4.0 also includes Low Energy Technology and ensures extraordinary low power consumption for PCs. The 2T2R WiFi solution sets a WiFi high speed standard and offers max link rate up to 866Mbps.

* The transmission speed may vary according to the environment.

* The WiFi + BT module is supported under Windows® 8 / 8 64-bit / 7 / 7 64-bit only.



ASRock WiFi 2.4GHz Antenna

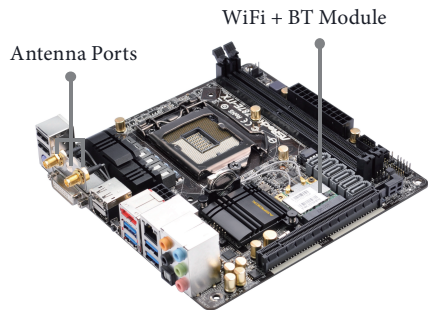

Chapter 2 Installation

This is a Mini-ITX form factor motherboard. Before you install the motherboard, study the configuration of your chassis to ensure that the motherboard fits into it.

Pre-installation Precautions

Take note of the following precautions before you install motherboard components or change any motherboard settings.

- Make sure to unplug the power cord before installing or removing the motherboard. Failure to do so may cause physical injuries to you and damages to motherboard components.
- In order to avoid damage from static electricity to the motherboard's components, NEVER place your motherboard directly on a carpet. Also remember to use a grounded wrist strap or touch a safety grounded object before you handle the components.
- Hold components by the edges and do not touch the ICs.
- Whenever you uninstall any components, place them on a grounded anti-static pad or in the bag that comes with the components.
- When placing screws to secure the motherboard to the chassis, please do not over-tighten the screws! Doing so may damage the motherboard.

2.1 Installing the CPU



1. Before you insert the 1150-Pin CPU into the socket, please check if the **PnP cap** is on the socket, if the CPU surface is unclean, or if there are any **bent pins** in the socket. Do not force to insert the CPU into the socket if above situation is found. Otherwise, the CPU will be seriously damaged.
2. Unplug all power cables before installing the CPU.

1

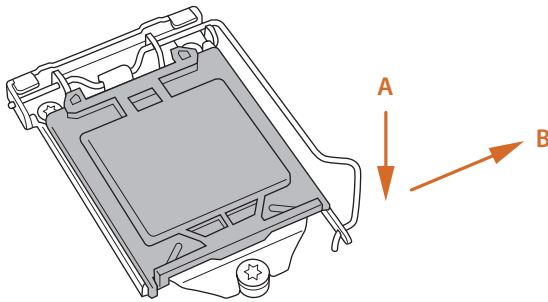

2

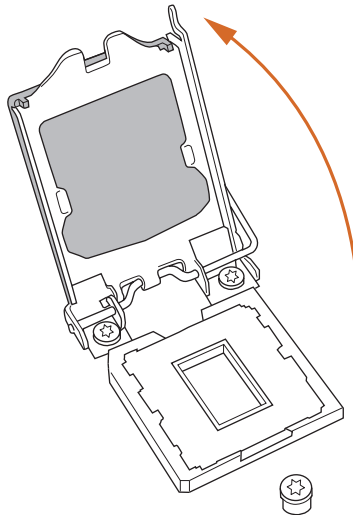

3

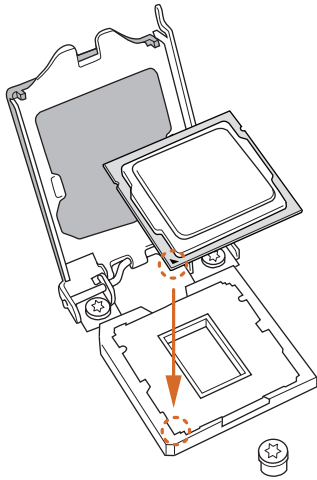

4

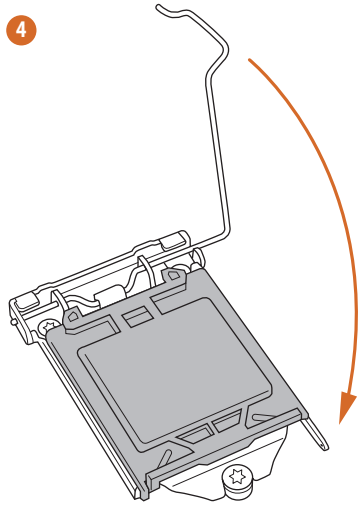

5

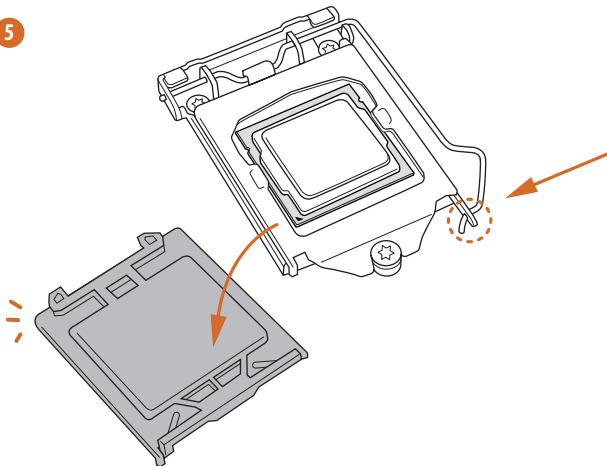



Please save and replace the cover if the processor is removed. The cover must be placed if you wish to return the motherboard for after service.

2.2 Installing the CPU Fan and Heatsink

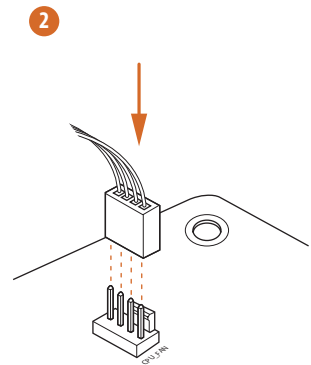
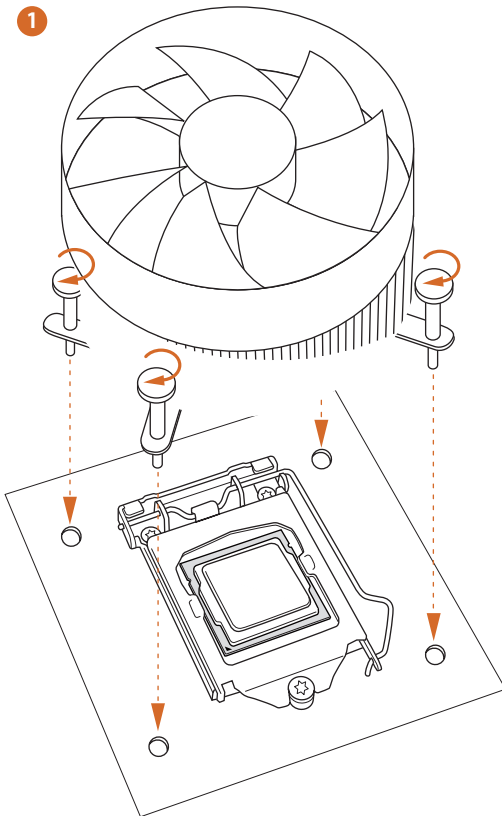
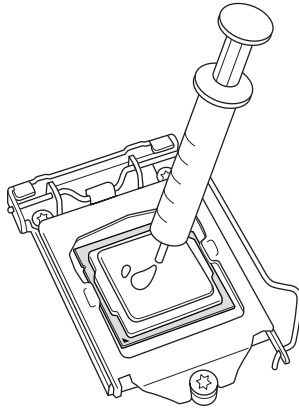

2.3 Installing Memory Modules (DIMM)

This motherboard provides two 240-pin DDR3 (Double Data Rate 3) DIMM slots, and supports Dual Channel Memory Technology.



1. For dual channel configuration, you always need to install identical (the same brand, speed, size and chip-type) DDR3 DIMM pairs.
2. It is unable to activate Dual Channel Memory Technology with only one memory module installed.
3. It is not allowed to install a DDR or DDR2 memory module into a DDR3 slot; otherwise, this motherboard and DIMM may be damaged.



The DIMM only fits in one correct orientation. It will cause permanent damage to the motherboard and the DIMM if you force the DIMM into the slot at incorrect orientation.

1

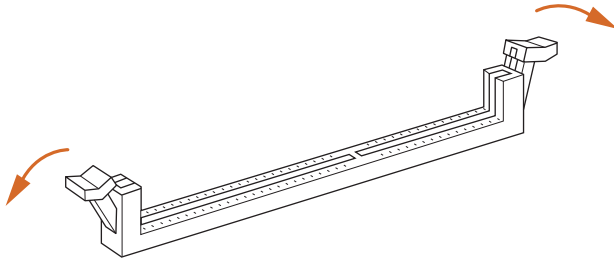

2

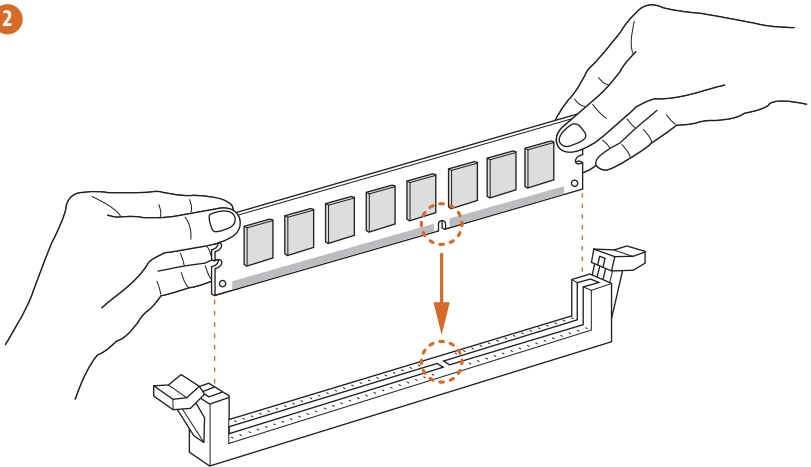

3

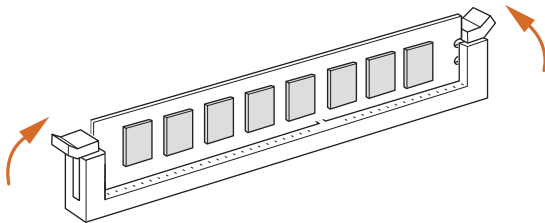

2.4 Expansion Slots (PCI and PCI Express Slots)

There is 1 PCI Express slot, 1 mini-PCI Express slot, and 1 mSATA/mini-PCI Express slot on this motherboard.



Before installing an expansion card, please make sure that the power supply is switched off or the power cord is unplugged. Please read the documentation of the expansion card and make necessary hardware settings for the card before you start the installation.

PCIe slots:

PCIE1 (PCIe 3.0 x16 slot) is used for PCI Express x16 lane width graphics cards.

MINI_PCIE1 (mini-PCIe slot) is used for WiFi module.

MINI_PCIE2 (mSATA/mini-PCIe slot) is used for mSATA or mini-PCIe module.

**** The mSATA/mini-PCIe slot is shared with SATA3_4 connector.*

2.5 Jumpers Setup

The illustration shows how jumpers are setup. When the jumper cap is placed on the pins, the jumper is “Short”. If no jumper cap is placed on the pins, the jumper is “Open”.

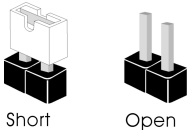

Clear CMOS Jumper
(CLR CMOS1)
(see p.1, No. 14)



Short: Clear CMOS
Open: Default

CLR CMOS1 allows you to clear the data in CMOS. The data in CMOS includes system setup information such as system password, date, time, and system setup parameters. To clear and reset the system parameters to default setup, please turn off the computer and unplug the power cord, then use a jumper cap to short the pins on CLR CMOS1 for 3 seconds. Please remember to remove the jumper cap after clearing the CMOS. If you need to clear the CMOS when you just finish updating the BIOS, you must boot up the system first, and then shut it down before you do the clear-CMOS action.



1. The Clear CMOS Switch has the same function as the Clear CMOS jumper.
2. If you clear the CMOS, the case open may be detected. Please adjust the BIOS option “Clear Status” to clear the record of previous chassis intrusion status.

2.6 Onboard Headers and Connectors



Onboard headers and connectors are NOT jumpers. Do NOT place jumper caps over these headers and connectors. Placing jumper caps over the headers and connectors will cause permanent damage to the motherboard.

System Panel Header
(9-pin PANEL1)
(see p.1, No. 12)

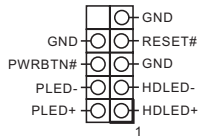

Connect the power switch, reset switch and system status indicator on the chassis to this header according to the pin assignments below. Note the positive and negative pins before connecting the cables.



PWRBTN (Power Switch):

Connect to the power switch on the chassis front panel. You may configure the way to turn off your system using the power switch.

RESET (Reset Switch):

Connect to the reset switch on the chassis front panel. Press the reset switch to restart the computer if the computer freezes and fails to perform a normal restart.

PLED (System Power LED):

Connect to the power status indicator on the chassis front panel. The LED is on when the system is operating. The LED keeps blinking when the system is in S1/S3 sleep state. The LED is off when the system is in S4 sleep state or powered off (S5).

HDLED (Hard Drive Activity LED):

Connect to the hard drive activity LED on the chassis front panel. The LED is on when the hard drive is reading or writing data.

The front panel design may differ by chassis. A front panel module mainly consists of power switch, reset switch, power LED, hard drive activity LED, speaker and etc. When connecting your chassis front panel module to this header, make sure the wire assignments and the pin assignments are matched correctly.

Serial ATA3 Connectors

(SATA3_0:
see p.1, No. 16)
(SATA3_1:
see p.1, No. 15)
(SATA3_2:
see p.1, No. 17)
(SATA3_3:
see p.1, No. 9)
(SATA3_4:
see p.1, No. 8)
(SATA3_5:
see p.1, No. 6)

SATA3_5



SATA3_4



SATA3_3



SATA3_2



SATA3_1



SATA3_0



These six SATA3 connectors support SATA data cables for internal storage devices with up to 6.0 Gb/s data transfer rate. SATA3_5 connector is shared with the eSATA port; SATA3_4 connector is shared with the mSATA/mini-PCIe slot.

USB 2.0 Headers

(9-pin USB_2_3)
(see p.1, No. 21)
(9-pin USB_4_5)
(see p.1, No. 20)

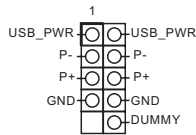

Besides two USB 2.0 ports on the I/O panel, there are two headers on this motherboard. Each USB 2.0 header can support two ports.

USB 3.0 Headers

(19-pin USB3_5_6)
(see p.1, No. 7)

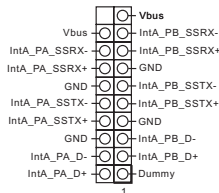

Besides four USB 3.0 ports on the I/O panel, there are one header on this motherboard. Each USB 3.0 header can support two ports.

Front Panel Audio Header
(9-pin HD_AUDIO1)
(see p.1, No. 21)

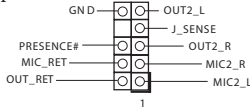

This header is for connecting audio devices to the front audio panel.



1. High Definition Audio supports Jack Sensing, but the panel wire on the chassis must support HDA to function correctly. Please follow the instructions in our manual and chassis manual to install your system.
2. If you use an AC'97 audio panel, please install it to the front panel audio header by the steps below:
 - A. Connect Mic_IN (MIC) to MIC2_L.
 - B. Connect Audio_R (RIN) to OUT2_R and Audio_L (LIN) to OUT2_L.
 - C. Connect Ground (GND) to Ground (GND).
 - D. MIC_RET and OUT_RET are for the HD audio panel only. You don't need to connect them for the AC'97 audio panel.
 - E. To activate the front mic, go to the "FrontMic" Tab in the Realtek Control panel and adjust "Recording Volume".

Chassis Speaker Header
(4-pin SPEAKER1)
(see p.1, No. 13)

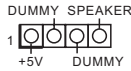

Please connect the chassis speaker to this header.

Chassis and Power Fan Connectors
(4-pin CHA_FAN1)
(see p.1, No. 4)

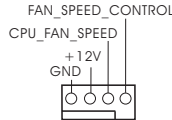

Please connect fan cables to the fan connectors and match the black wire to the ground pin.

CPU Fan Connectors
(4-pin CPU_FAN1)
(see p.1, No. 1)

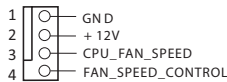

This motherboard provides a 4-Pin CPU fan (Quiet Fan) connector. If you plan to connect a 3-Pin CPU fan, please connect it to Pin 1-3.

ATX Power Connector
(24-pin ATXPWR1)
(see p.1, No. 5)

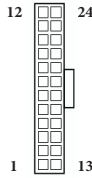

This motherboard provides a 24-pin ATX power connector. To use a 20-pin ATX power supply, please plug it along Pin 1 and Pin 13.

ATX 12V Power Connector
(8-pin ATX12V1)
(see p.1, No. 2)

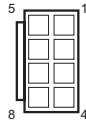

This motherboard provides an 8-pin ATX 12V power connector. To use a 4-pin ATX power supply, please plug it along Pin 1 and Pin 5.

Chassis Intrusion Header
(2-pin C11)
(see p.1, No. 11)



This motherboard supports CASE OPEN detection feature that detects if the chassis cover has been removed. This feature requires a chassis with chassis intrusion detection design.

TPM Header
(17-pin TPMS1)
(see p.1, No. 10)

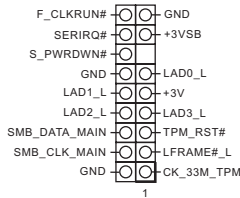

This connector supports Trusted Platform Module (TPM) system, which can securely store keys, digital certificates, passwords, and data. A TPM system also helps enhance network security, protects digital identities, and ensures platform integrity.

1 Einleitung

Vielen Dank, dass Sie sich für das Z87E-ITX von ASRock entschieden haben – ein zuverlässiges Motherboard, das konsequent unter der strengen Qualitätskontrolle von ASRock hergestellt wurde. Es liefert ausgezeichnete Leistung mit robustem Design, das ASRocks Streben nach Qualität und Beständigkeit erfüllt.



Da die technischen Daten des Motherboards sowie die BIOS-Software aktualisiert werden können, kann der Inhalt dieser Dokumentation ohne Ankündigung geändert werden. Falls diese Anleitung irgendwelchen Änderungen unterliegt, wird die aktualisierte Version ohne weitere Hinweise auf der ASRock-Webseite zur Verfügung gestellt. Sollten Sie technische Hilfe in Bezug auf dieses Motherboard benötigen, erhalten Sie auf unserer Webseite spezifischen Informationen über das von Ihnen verwendete Modell. Auch finden Sie eine aktuelle Liste unterstützter VGA-Karten und Prozessoren auf der ASRock-Webseite: ASRock-Webseite <http://www.asrock.com>.

1.1 Lieferumfang

- ASRock Z87E-ITX-Motherboard (Mini-ITX-Formfaktor)
- ASRock Z87E-ITX-Schnellinstallationsanleitung
- ASRock Z87E-ITX-Support-CD
- 4 x Serial-ATA- (SATA) Datenkabel (optional)
- 1 x E/A-Blendenabschirmung
- 1 x 2,4-GHz-WLAN-Antenne von ASRock
- 1 x DVI-zu-D-Sub-Wandler

1.2 Technische Daten

- Plattform**
- Mini-ITX-Formfaktor
 - Premium Gold-Kondensatordesign (100 % in Japan gefertigt, hochqualitative leitfähige Polymer-Kondensatoren)

- Prozessor**
- Unterstützt Intel® Core™ i7 / i5 / i3 / Xeon® / Pentium® / Celeron® der 4. Generation im LGA1150-Paket
 - Digipower-Design
 - 6-Leistungsphasendesign
 - DrMOS
 - Unterstützt Intel® Turbo Boost 2.0-Technologie
 - Unterstützt CPU mit freiem Multiplikator der Intel® K-Serie

- Chipsatz**
- Intel® Z87

- Speicher**
- Dualkanal-DDR3-Speichertechnologie
 - 2 x DDR3-DIMM-Steckplätze
 - Unterstützt DDR3 2933+(OC)/2800(OC)/2400(OC)/2133(OC) / 1866(OC)/1600/1333/1066 non-ECC, ungepufferter Speicher
 - Systemspeicher, max. Kapazität: 16GB (siehe ACHTUNG)
 - Unterstützt Intel® Extreme Memory Profile (XMP)1.3/1.2

- Erweiterungssteckplatz**
- 1 x PCI-Express 3.0-x16-Steckplatz
 - 1 x Mini-PCI-Express-Steckplatz (halbe Größe): Für WiFi- + BT-Modul
 - 1 x mSATA/Mini-PCI-Express-Steckplatz (volle Größe):

- Grafikkarte**
- Integrierte Intel® HD Graphics-Visualisierung und VGA-Ausgänge können nur mit Prozessoren unterstützt werden, die GPU-integriert sind.
 - Unterstützt integrierte Intel® HD Graphics-Visualisierung: Intel® Quick Sync Video mit AVC, MVC (S3D) und MPEG-2 Full HW Encode1, Intel® InTru™ 3D, Intel® Clear Video HD Technology, Intel® Insider™, Intel® HD Graphics 4400/4600
 - Pixel Shader 5.0, DirectX 11.1
 - Max. geteilter Speicher: 1792 MB

- Drei VGA-Ausgangsoptionen: DVI-I, HDMI und DisplayPort
- Unterstützt drei Monitore
- Unterstützt HDMI Technologie mit maximaler Auflösung von 4K x 2K (4096 x 2304) bei 24 Hz
- Unterstützt DVI-I mit maximaler Auflösung von 1920 x 1200 bei 60 Hz
- Unterstützt DisplayPort mit maximaler Auflösung von 3840 x 2160 bei 60 Hz
- Unterstützt Auto-Lippensynchronizität, hohe Farbtiefe (12 bpc), xvYCC und HBR (Audio mit hoher Bitrate) mit HDMI (konformer HDMI-Monitor erforderlich)
- Unterstützt HDCP-Funktion mit DVI-I-, HDMI- und DisplayPort-Ports
- Unterstützt Blu-ray- (BD) (Full HD/1080p) / HD-DVD-Wiedergabe mit DVI-I-, HDMI-, und DisplayPort-Ports

Audio

- 7.1-Kanal-HD-Audio mit Inhaltsschutz (Realtek ALC1150-Audiocodec)
- Erstklassige Blu-ray-Audiounterstützung
- TI® NE5532 (unterstützt erstklassigen Headset-Verstärker mit bis zu 600 Ohm)
- Unterstützt DTS Connect

LAN

- Gigabit LAN 10/100/1000 Mb/s
- Giga PHY Intel® I217V
- Unterstützt Intel® Remote Wake Technology
- Unterstützt Wake-On-LAN
- Unterstützt energieeffizientes Ethernet 802.3az
- Unterstützt PXE

Wireless LAN

- Unterstützt IEEE 802.11a/b/g/n/ac
- Unterstützt Dualband (2,4/5 GHz)
- Unterstützt High-Speed-Drahtlosverbindung bis 867 Mb/s
- 2 Antennen zur Unterstützung von Diversitätstechnologie 2 (senden) x 2 (empfangen)
- Unterstützt Bluetooth 4.0 / 3.0 + High-Speed, Klasse II

**Rückblende,
E/A**

- 1 x PS/2-Maus-/Tastaturanschluss
- 1 x DVI-I-Port
- 1 x HDMI-Port
- 1 x DisplayPort
- 1 x Optischer SPDIF-Ausgang
- 1 x eSATA-Anschluss
- 2 x USB 2.0-Ports
- 4 x USB 3.0-Ports
- 1 x RJ-45-LAN-Port mit LED (Aktivität/Verbindung-LED und Geschwindigkeit-LED)
- 1 x CMOS-löschen-Schalter
- HD-Audioanschluss: Hintere Lautsprecher / Zentral / Bass / Line-in / Vorderer Lautsprecher /Mikrofon

Speicher

- 6 x SATA-III-6,0-Gb/s-Anschlüsse, unterstützt RAID (RAID 0, RAID 1, RAID 5, RAID 10, Intel Rapid Storage Technology 12 und Intel Smart Response Technology), NCQ, AHCI und „Hot-Plugging“ (SATA3_5-Anschluss wird mit eSATA-Port geteilt; SATA3_4-Anschluss wird mit mSATA/Mini-PCI-Express-Steckplatz geteilt)
- 1 x eSATA-Anschluss, unterstützt NCQ, AHCI und „Hot-Plugging“-Funktionen
- 1 x mSATA-6,0-Gb/s-Anschluss (Solid-State Drive-Anschluss), unterstützt NCQ-, AHCI-Funktionen und Mini-PCI-Express-Module in voller Größe

Anschluss

- 1 x Gehäuseeingriff-Stiftleiste
- 1 x TPM-Stiftleiste
- 1 x CPU-Lüfteranschluss (4-polig)
- 1 x Gehäuselüfteranschluss (4-polig)
- 1 x 24-poliger ATX-Netzanschluss
- 1 x 8-poliger 12-V-Netzanschluss (hochdichter Netzanschluss)
- 1 x Audioanschluss an Frontblende
- 2 x USB 2.0-Stiftleisten (unterstützt vier USB 2.0-Ports)
- 1 x USB 3.0-Stiftleiste (unterstützt zwei USB 3.0-Ports)

**BIOS-
Funktion**

- 64-Mb-AMI-UEFI-Legal-BIOS mit Unterstützung mehrsprachiger grafischer Benutzerschnittstellen
- ACPI 1.1-konforme Aufweckereignisse
- SMBIOS 2.3.1-Unterstützung
- CPU, DRAM, PCH 1,05 V, PCH 1,5 V / Mehrfachspannungsanpassung

Support-CD

- Treiber, Dienstprogramme, Antivirensoftware (Testversion), CyberLink MediaEspresso 6.5-Testversion, Google Chrome Browser und Toolbar, Start8, MeshCentral, Splashtop Streamer, Intel® Extreme Tuning Utility (IXTU)

**Hardware-
überwachung**

- CPU-/Gehäusetemperaturerkennung
- CPU-/Gehäusetachometer
- Lautloser CPU-/Gehäuselüfter (ermöglicht automatische Anpassung der Geschwindigkeit des Gehäuselüfters über die CPU-Temperatur)
- CPU/Gehäuselüfter-Mehrfachgeschwindigkeitssteuerung
- Spannungsüberwachung: +12 V, +5 V, +3,3 V, CPU Vcore

Betriebssystem

- Konform mit Microsoft® Windows® 8 / 8, 64 Bit / 7 / 7, 64 Bit

Zertifizierungen

- FCC, CE, WHQL
- ErP/EuP ready (ErP/EuP ready-Netzteil erforderlich)

* Detaillierte Produktinformationen finden Sie auf unserer Webseite: <http://www.asrock.com>



Bitte beachten Sie, dass mit einer Übertaktung, zu der die Anpassung von BIOS-Einstellungen, die Anwendung der Untied Overclocking Technology oder die Nutzung von Übertaktungswerkzeugen von Drittanbietern zählen, bestimmte Risiken verbunden sind. Eine Übertaktung kann sich auf die Stabilität Ihres Systems auswirken und sogar Komponenten und Geräte Ihres Systems beschädigen. Sie sollte auf eigene Gefahr und eigene Kosten durchgeführt werden. Wir übernehmen keine Verantwortung für mögliche Schäden, die durch eine Übertaktung verursacht wurden.



Aufgrund von Beschränkungen kann die Größe des tatsächlich für die Systemnutzung reservierten Speichers unter Windows®-Betriebssystemen mit 32 Bit weniger als 4 GB betragen. Windows®-Betriebssysteme mit 64 Bit haben keine derartigen Beschränkungen. Mit ASRock XFast RAM können Sie den Speicher einsetzen, den Windows® nicht nutzen kann.

1.3 JumperEinstellung

Die Abbildung zeigt, wie die Jumper eingestellt werden. Wenn die Jumper-Kappe auf den Kontakten angebracht ist, ist der Jumper „kurzgeschlossen“. Wenn keine Jumper-Kappe auf den Kontakten angebracht ist, ist der Jumper „offen“.

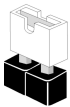

Short



Open

CMOS-löschen-Jumper
(CLRCMOS1)
(siehe S. 1, Nr. 14)



2-poliger Jumper

Kurzgeschlossen: CMOS löschen
Offen: Standard

CLRCMOS1 ermöglicht Ihnen die Löschung der Daten im CMOS. Die Daten im CMOS beinhaltet Systemeinrichtungsinformationen, wie Systemkennwort, Datum, Zeit und Systemeinrichtungparameter. Zum Löschen und Rücksetzen der Systemparameter auf die Standardeinrichtung schalten Sie den Computer bitte ab und ziehen das Netzkabel; schließen Sie dann die Kontakte an CLRCMOS1 3 Sekunden mit einer Jumper-Kappe kurz. Bitte denken Sie daran, die Jumper-Kappe nach der CMOS-Löschung zu entfernen. Falls Sie den CMOS direkt nach Abschluss der BIOS-Aktualisierung löschen müssen, starten Sie das System zunächst; fahren Sie es dann vor der CMOS-Löschung herunter.



1. Der CMOS-löschen-Schalter hat dieselbe Funktion wie der CMOS-löschen-Jumper.
2. Falls Sie den CMOS löschen, wird möglicherweise ein Gehäuseeingriff erkannt. Bitte passen Sie die BIOS-Option „Status löschen“ zur Löschung der Aufzeichnung des vorherigen Gehäuseeingriffstatus an.

1.4 Integrierte Stiftleisten und Anschlüsse



Integrierte Stiftleisten und Anschlüsse sind KEINE Jumper. Bringen Sie KEINE Jumper-Kappen an diesen Stiftleisten und Anschlüssen an. Durch Anbringen von Jumper-Kappen an diesen Stiftleisten und Anschlüssen können Sie das Motherboard dauerhaft beschädigen.

Systemblende-Stiftleiste
(9-polig, PANEL1)
(siehe S. 1, Nr. 12)

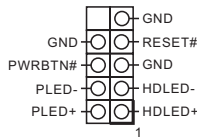

Verbinden Sie Netzschalter, Reset-Taste und Systemstatusanzeige am Gehäuse entsprechend der nachstehenden Pinbelegung mit dieser Stiftleiste. Beachten Sie vor Anschließen der Kabel die positiven und negativen Kontakte.



PWRBTN (Ein-/Austaste):

Mit der Ein-/Austaste an der Frontblende des Gehäuses verbinden. Sie können die Abschaltung Ihres Systems über die Ein-/Austaste konfigurieren.

RESET (Reset-Taste):

Mit der Reset-Taste an der Frontblende des Gehäuses verbinden. Starten Sie den Computer über die Reset-Taste neu, wenn er abstürzt oder sich nicht normal neu starten lässt.

PLED (Systembetrieb-LED):

Mit der Betriebsstatusanzeige an der Frontblende des Gehäuses verbinden. Die LED leuchtet, wenn das System läuft. Die LED blinkt, wenn sich das System im S1/S3-Ruhezustand befindet. Die LED ist aus, wenn sich das System im S4-Ruhezustand befindet oder ausgeschaltet ist (S5).

HDLED (Festplattenaktivität-LED):

Mit der Festplattenaktivität-LED an der Frontblende des Gehäuses verbinden. Die LED leuchtet, wenn die Festplatte Daten liest oder schreibt.

Das Design der Frontblende kann je nach Gehäuse variieren. Ein Frontblendenmodul besteht hauptsächlich aus Ein-/Austaste, Reset-Taste, Betrieb-LED, Festplattenaktivität-LED, Lautsprecher etc. Stellen Sie beim Anschließen Ihres Frontblendenmoduls an diese Stiftleiste sicher, dass Kabel- und Pinbelegung richtig abgestimmt sind.

Serial-ATA-III-Anschlüsse
 (SATA3_0: siehe S. 1, Nr. 16)
 (SATA3_1: siehe S. 1, Nr. 15)
 (SATA3_2: siehe S. 1, Nr. 17)
 (SATA3_3: siehe S. 1, Nr. 9)
 (SATA3_4: siehe S. 1, Nr. 8)
 (SATA3_5: siehe S. 1, Nr. 6)



Diese sechs SATA-III-Anschlüsse unterstützen SATA-Datenkabel für interne Speichergeräte mit einer Datenübertragungsgeschwindigkeit bis 6,0 Gb/s. SATA3_5-Anschluss wird mit eSATA-Port geteilt; SATA3_4-Anschluss wird mit mSATA/Mini-PCIe-Steckplatz geteilt.

USB 2.0-Stiftleisten
 (9-polig, USB_2_3)
 (siehe S. 1, Nr. 21)
 (9-polig, USB_4_5)
 (siehe S. 1, Nr. 20)

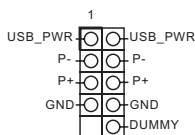

Neben zwei USB 2.0-Ports an der E/A-Blende befinden sich zwei Stiftleisten an diesem Motherboard. Jede USB 2.0-Stiftleiste kann zwei Ports unterstützen.

USB 3.0-Stiftleisten
 (19-polig, USB3_5_6)
 (siehe S. 1, Nr. 7)

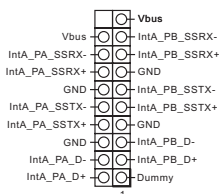

Neben vier USB 3.0-Ports an der E/A-Blende befindet sich eine Stiftleiste an diesem Motherboard. Jede USB 3.0-Stiftleiste kann zwei Ports unterstützen.

Audiostiftleiste

(Frontblende)

(9-polig, HD_AUDIO1)

(siehe S. 1, Nr. 21)

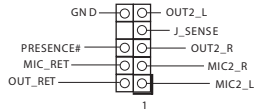

Diese Stiftleiste dient dem Anschließen von Audiogeräten an der Frontblende.



- High Definition Audio unterstützt Anschlusserkennung, der Draht am Gehäuse muss dazu jedoch HDA unterstützt. Bitte befolgen Sie zum Installieren Ihres Systems die Anweisungen in unserer Anleitung und der Anleitung zum Gehäuse.
- Wenn Sie ein AC'97-Audiopanel nutzen, installieren Sie es bitte anhand der nachstehenden Schritte an der Audiostiftleiste (Frontblende):
 - Verbinden Sie Mic_IN (MIC) mit MIC2_L.
 - Verbinden Sie Audio_R (RIN) mit OUT2_R und Audio_L (LIN) mit OUT2_L.
 - Verbinden Sie Erde (GND) mit Erde (GND).
 - MIC_RET und OUT_RET sind nur für das HD-Audio-Panel vorgesehen. Sie müssen Sie nicht mit dem AC'97-Audiopanel verbinden.
 - Rufen Sie zur Aktivierung des vorderen Mikrofons das „FrontMic (Frontmikrofon)“-Register in der Realtek-Systemsteuerung auf und passen „Recording Volume (Aufnahmelautstärke)“ an.

Gehäuselautsprecherstiftleiste

(4-polig, SPEAKER1)

(siehe S. 1, Nr. 13)

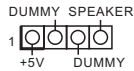

Bitte verbinden Sie den Gehäuselautsprecher mit dieser Stiftleiste.

Gehäuse- und Netzteil Lüfteranschlüsse

(4-polig, CHA_FAN1)

(siehe S. 1, Nr. 4)

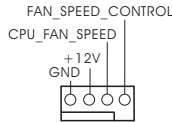

Bitte verbinden Sie die Lüfterkabel mit den Lüfteranschlüssen; der schwarze Draht gehört zum Erdungskontakt.

CPU-Lüfteranschlüsse

(4-polig, CPU_FAN1)

(siehe S. 1, Nr. 1)

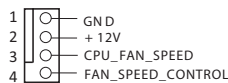

Dieses Motherboard bietet einen 4-poligen CPU-Lüfteranschluss (lautloser Lüfter). Falls Sie einen 3-poligen CPU-Lüfter anschließen möchten, verbinden Sie ihn bitte mit Kontakt 1 bis 3.

ATX-Netzanschluss
(24-polig, ATXPWR1)
(siehe S. 1, Nr. 5)

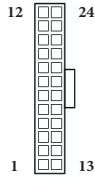

Dieses Motherboard bietet einen 24-poligen ATX-Netzanschluss. Bitte schließen Sie es zur Nutzung eines 20-poligen ATX-Netzteils entlang Kontakt 1 und Kontakt 13 an.

ATX-12-V-Netzanschluss
(8-polig, ATX12V1)
(siehe S. 1, Nr. 2)

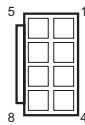

Dieses Motherboard bietet einen 8-poligen ATX-12-V-Netzanschluss. Bitte schließen Sie es zur Nutzung eines 4-poligen ATX-Netzteils entlang Kontakt 1 und Kontakt 5 an.

Gehäuseeingriff-
Stiftleiste
(2-polig, CII)
(siehe S. 1, Nr. 11)



Dieses Motherboard unterstützt die Gehäuse-offen-Erkennung, die erkennt, wenn die Gehäuseabdeckung entfernt wurde. Diese Funktion setzt ein Gehäuse mit Gehäuseeingriffserkennungssignal voraus.

TPM-Stiftleiste
(17-polig, TPMS1)
(siehe S. 1, Nr. 10)

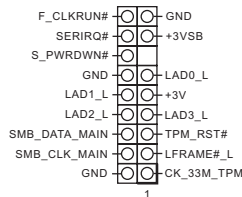

Dieser Anschluss unterstützt das Trusted Platform Module (TPM) System, das Schlüssel, digitale Zertifikate, Kennwörter und Daten sicher aufbewahren kann. Ein TPM-System hilft zudem bei der Stärkung der Netzwerksicherheit, schützt digitale Identitäten und gewährleistet die Plattformintegrität.

1 Introduction

Nous vous remercions d'avoir acheté cette carte mère ASRock Z87E-ITX, une carte mère fiable fabriquée conformément au contrôle de qualité rigoureux et constant appliqué par ASRock. Fidèle à son engagement de qualité et de durabilité, ASRock vous garantit une carte mère de conception robuste aux performances élevées.



Les spécifications de la carte mère et du logiciel BIOS pouvant être mises à jour, le contenu de ce document est soumis à modification sans préavis. En cas de modifications du présent document, la version mise à jour sera disponible sur le site Internet ASRock sans notification préalable. Si vous avez besoin d'une assistance technique pour votre carte mère, veuillez visiter notre site Internet pour plus de détails sur le modèle que vous utilisez. La liste la plus récente des cartes VGA et des processeurs pris en charge est également disponible sur le site Internet de ASRock. Site Internet ASRock <http://www.asrock.com>.

1.1 Contenu de l'emballage

- Carte mère ASRock Z87E-ITX (facteur de forme Mini-ITX)
- Guide d'installation rapide ASRock Z87E-ITX
- CD d'assistance ASRock Z87E-ITX
- 4 x câbles de données Serial ATA (SATA) (Optionnel)
- 1 x panneau de protection E/S
- 1 x antenne WiFi 2,4GHz ASRock
- 1 x convertisseur DVI-vers-D-Sub

1.2 Spécifications

- Plateforme**
- Facteur de forme Mini-ITX
 - Condensateur de conception premium or (condensateurs haute qualité en polymère conducteur 100% fabriqués au Japon)

- Processeur**
- Prend en charge les processeurs 4^{ème} Génération Intel® Core™ i7 / i5 / i3 / Xeon® / Pentium® / Celeron® en package LGA1150
 - Conception Digi Power
 - Alimentation à 6 phases
 - DrMOS
 - Prend en charge la technologie Intel® Turbo Boost 2.0
 - Prend en charge les processeurs débloqués de la série K Intel®

- Chipset**
- Intel® Z87

- Mémoire**
- Technologie mémoire double canal DDR3
 - 2 x fentes DIMM DDR3
 - Prend en charge les mémoires sans tampon non ECC DDR3 2933+(OC)/2800(OC)/2400(OC)/2133(OC)/1866(OC)/1600/1333/1066
 - Capacité max. de la mémoire système : 16Go (voir AVERTISSEMENT)
 - Prend en charge Intel® Extreme Memory Profile (XMP)1.3/1.2

- Fente d'expansion**
- 1 x fente PCI Express 3.0 x16
 - 1 x fente PCI Express half mini : pour module WiFi + BT
 - 1 x fente mSATA/ PCI Express full mini

- Graphiques**
- La technologie Intel® HD Graphics Built-in Visuals et les sorties VGA sont uniquement prises en charge par les processeurs intégrant un contrôleur graphique.
 - Prend en charge la technologie Intel® HD Graphics Built-in Visuals : Intel® Quick Sync Video with AVC, MVC (S3D) and MPEG-2 Full HW Encode1, Intel® InTru™ 3D, Intel® Clear Video HD Technology, Intel® Insider™, Intel® HD Graphics 4400/4600
 - Pixel Shader 5.0, DirectX 11.1
 - Mémoire partagée max. 1792Mo

- Trois options de sortie VGA : DVI-I, HDMI et DisplayPort
- Prend en charge la configuration à triple moniteurs
- Prend en charge la technologie HDMI 1.4a avec une résolution maximale de 4K × 2K (4096x2304) @ 24Hz
- Prend en charge le mode DVI-I avec une résolution maximale de 1920x1200 @ 60Hz
- Prend en charge le mode DisplayPort avec une résolution maximale de 3840x2160 @ 60Hz
- Prend en charge les technologies Auto Lip Sync, Deep Color (12bpc), xvYCC et HBR (High Bit Rate Audio) avec HDMI (un écran compatible HDMI est requis)
- Prend en charge la fonction HDCP via ports DVI-I, HDMI et DisplayPort
- Prend en charge la lecture Blu-ray (BD) / HD-DVD Full HD 1080p via ports DVI-I, HDMI et DisplayPort

Audio

- Audio 7.1 CH HD avec protection du contenu (codec audio Realtek ALC1150)
- Compatible audio Blu-ray Premium
- TI® NE5532 (compatible Premium Headset Amplifier jusqu'à 600 Ohms)
- Prend en charge DTS Connect

Réseau

- Gigabit LAN 10/100/1000 Mb/s
- Giga PHY Intel® I217V
- Prend en charge la technologie Intel® Remote Wake
- Prend en charge la fonction Wake-On-LAN
- Prend en charge la fonction d'économie d'énergie Ethernet 802.3az
- Prend en charge PXE

Réseau sans-fil

- Prend en charge IEEE 802.11a/b/g/n/ac
- Prend en charge le mode Dual-Band (2,4/5 GHz)
- Prend en charge la connexion sans-fil à haute vitesse jusqu'à 867Mbps
- 2 antennes pour prendre en charge la technologie diversifiée 2 (émission) x 2 (réception)
- Prend en charge Bluetooth 4.0 / 3.0 + haute vitesse classe II

Connectique du panneau arrière

- 1 x port souris/clavier PS/2
- 1 x port DVI-I
- 1 x port HDMI
- 1 x DisplayPort
- 1 x port sortie optique SPDIF
- 1 x connecteur eSATA
- 2 x ports USB 2.0
- 4 x ports USB 3.0
- 1 x port RJ-45 LAN avec LED (LED ACT/LIEN et LED VITESSE)
- 1 x bouton Clear CMOS
- Connecteurs jack audio HD : Haut-parleur arrière / central / basses / entrée ligne / haut-parleur avant / microphone

Stockage

- 6 x connecteurs SATA3 6,0 Go/s, compatibles RAID (RAID 0, RAID 1, RAID 5, RAID 10, et technologies Intel Rapid Storage 12 et Intel Smart Response), NCQ, AHCI et « Hot Plug » (le connecteur SATA3_5 est partagé avec le port eSATA ; le connecteur SATA3_4 est partagé avec la fente mSATA/mini-PCI Express)
- 1 x connecteur eSATA, compatible avec les fonctions NCQ, AHCI et « Hot Plug »
- 1 x connecteur mSATA 6,0 Go/s (connecteur SSD - Solid-State Drive), compatible avec les fonctions NCQ, AHCI et modules mini-PCI Express Full-size

Connectique

- 1 x embase d'intrusion châssis
- 1 x embase TPM
- 1 x connecteur pour ventilateur de CPU (4 broches)
- 1 x connecteur pour ventilateur de châssis (4 broches)
- 1 x connecteur d'alimentation ATX 24 broches
- 1 x connecteur d'alimentation 12V 8 broches (connecteur d'alimentation haute densité)
- 1 x connecteur audio panneau frontal
- 2 x embases USB 2.0 (pour 4 ports USB 2.0)
- 1 x embase USB 3.0 (pour 2 ports USB 3.0)

BIOS

- BIOS UEFI AMI 64Mo avec prise en charge d'interface graphique multilingue
- Compatible ACPI 1.1 Wake Up Events
- Prend en charge SMBIOS 2.3.1
- Réglage de la tension CPU, DRAM, PCH 1,05V, PCH 1,5V

CD inclus

- Utilitaires, logiciel AntiVirus (version d'évaluation), version d'essai CyberLink MediaEspresso 6.5, navigateur Google Chrome et barre d'outils, Start8, MeshCentral, Splashtop Streamer, utilitaire Intel® Extreme Tuning (IXTU)

Surveillance du matériel

- Détection de la température du processeur/châssis
- Tachéomètre processeur/châssis
- Fonction ventilateur silencieux processeur/châssis Quiet Fan (permet au ventilateur du châssis d'adapter sa vitesse de rotation automatiquement en fonction de la température du processeur)
- Contrôle simultané des vitesse du ventilateur processeur/châssis
- Surveillance de la tension d'alimentation : +12V, +5V, +3,3V, CPU Vcore

Système d'exploitation

- Compatible Microsoft® Windows® 8 / 8 64-bit / 7 / 7 64-bits

Certifications

- FCC, CE, WHQL
- ErP/EuP Ready (alimentation ErP/EuP ready requise)

* pour des informations détaillées de nos produits, veuillez visiter notre site : <http://www.asrock.com>



Il est important de signaler que l'overclocking présente certains risques, incluant des modifications du BIOS, l'application d'une technologie d'overclocking déliée et l'utilisation d'outils d'overclocking développés par des tiers. La stabilité de votre système peut être affectée par ces pratiques, voire provoquer des dommages aux composants et aux périphériques du système. L'overclocking se fait à vos risques et périls. Nous ne pourrions en aucun cas être tenus pour responsables des dommages éventuels provoqués par l'overclocking.



En raison de limitations dues au système d'exploitation, la capacité de mémoire utilisée sous Windows® 32-bit peut être inférieure à 4 Go. Cette limitation ne concerne pas les systèmes d'exploitation Windows® 64-bit. Vous pouvez utiliser ASRock XFast RAM pour utiliser la mémoire dont Windows® ne peut se servir.

1.3 Configuration des cavaliers (jumpers)

L'illustration ci-dessous vous renseigne sur la configuration des cavaliers (jumpers). Lorsque le capuchon du cavalier est installé sur les broches, le cavalier est 'court-circuité'. Si le capuchon du cavalier n'est pas installé sur les broches, le cavalier est

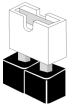

Short



Open

Cavalier Clear CMOS
(CLR CMOS1)
(voir p.1, No. 14)



Cavalier (jumper) à 2
broches

Court-circuité : Clear CMOS
Ouvert : Par défaut

CLR CMOS1 vous permet d'effacer les données de la CMOS. Les données de la CMOS incluent les informations de configuration du système telles que mot de passe, date, heure et paramètres de réglage du système. Pour effacer les paramètres du système et rétablir les valeurs par défaut, veuillez éteindre votre ordinateur et débrancher son cordon d'alimentation ; utilisez ensuite un capuchon de cavalier pour court-circuiter les broches CLR CMOS1 pendant 3 secondes. N'oubliez pas de retirer le capuchon du cavalier une fois les données CMOS effacées. Si vous avez besoin d'effacer les données CMOS après une mise à jour du BIOS, vous devez tout d'abord redémarrer le système, puis l'éteindre avant de procéder à l'effacement de la CMOS.



1. Le bouton Clear CMOS possède la même fonction que le cavalier (jumper) Clear CMOS.
2. Si vous effacez la CMOS, l'alerte de châssis ouvert peut se déclencher. Veuillez régler l'option du BIOS sur « Effacer » pour supprimer l'historique des intrusions de châssis précédentes.

1.4 Embases et connecteurs de la carte mère



Les embases et connecteurs situés sur la carte NE SONT PAS des cavaliers. Ne placez JAMAIS de capuchons de cavaliers sur ces embases ou connecteurs. Placer un capuchon de cavalier sur ces embases ou connecteurs endommagera irrémédiablement votre carte mère.

Embase du panneau système
(PANNEAU1 à 9 broches)
(voir p.1, No. 12)

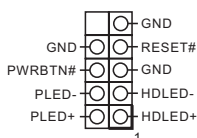

Branchez le bouton de mise en marche, le bouton de réinitialisation et le témoin d'état du système présents sur le châssis sur cette embase en respectant la configuration des broches illustrée ci-dessous. Repérez les broches positive et négative avant de brancher les câbles.



PWRBTN (Bouton de mise en marche) :

pour brancher le bouton de mise en marche au panneau frontal du châssis. Vous pouvez configurer la façon dont votre système doit s'arrêter à l'aide du bouton de mise en marche.

RESET (Bouton de réinitialisation) :

pour brancher le bouton de réinitialisation au panneau frontal du châssis. Appuyez sur le bouton de réinitialisation pour redémarrer l'ordinateur en cas de plantage ou de dysfonctionnement au démarrage.

PLED (LED d'alimentation du système) :

pour brancher le témoin d'état de l'alimentation au panneau frontal du châssis. Le LED est allumé lorsque le système fonctionne. Le LED clignote lorsque le système se trouve en mode veille S1/S3. Le LED est éteint lorsque le système se trouve en mode veille S4 ou hors tension (S5).

HDLED (LED d'activité du disque dur) :

pour brancher le témoin LED d'activité du disque dur au panneau frontal du châssis. Le LED est allumé lorsque le disque dur lit ou écrit des données.

La conception du panneau frontal peut varier en fonction du châssis. Un module de panneau frontal est principalement composé d'un bouton de mise en marche, bouton de réinitialisation, LED d'alimentation, LED d'activité du disque dur, haut-parleur etc. Lorsque vous reliez le module du panneau frontal de votre châssis sur cette embase, veillez à parfaitement faire correspondre les fils et les broches.

Connecteurs Serial ATA3

(SATA3_0:
voir p. 1, No. 16)
(SATA3_1:
voir p.1, No. 15)
(SATA3_2:
voir p.1, No. 17)
(SATA3_3:
voir p.1, No. 9)
(SATA3_4:
voir p.1, No. 8)
(SATA3_5:
voir p.1, No. 6)



Ces six connecteurs SATA3 sont compatibles avec les câbles de données SATA pour les appareils de stockage internes avec un taux de transfert maximal de 6,0 Go/s. Le connecteur SATA3_5 est partagé avec le port eSATA ; le connecteur SATA3_4 est partagé avec la fente mSATA/mini-PCIE.

Embases USB 2.0

(USB_2_3 à 9 broches)
(voir p.1, No. 21)
(USB_4_5 à 9 broches)
(voir p.1, No. 20)

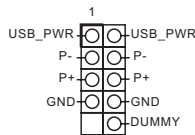

En plus des deux ports USB 2.0 sur le panneau E/S, cette carte mère est dotée de deux embases. Chaque embase USB 2.0 peut prendre en charge deux ports.

Embases USB 3.0

(USB3_5_6 à 19 broches)
(voir p.1, No. 7)

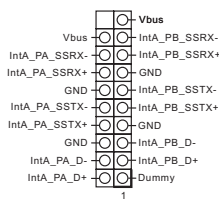

En plus des quatre ports USB 3.0 sur le panneau E/S, cette carte mère est dotée d'une embase supplémentaire. Chaque embase USB 3.0 peut prendre en charge deux ports.

Embase audio du panneau frontal
(HD_AUDIO1 à 9 broches)
(voir p.1, No. 21)

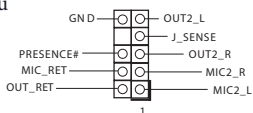

Cette embase sert au branchement des appareils audio au panneau audio frontal.



- L'audio haute définition prend en charge la technologie Jack Sensing (détection de la fiche), mais le panneau grillagé du châssis doit être compatible avec la HDA pour fonctionner correctement. Veuillez suivre les instructions figurant dans notre manuel et dans le manuel du châssis pour installer votre système.
- Si vous utilisez un panneau audio AC'97, veuillez le brancher sur l'embase audio du panneau frontal en procédant comme suit :
 - branchez Mic_IN (MIC) sur MIC2_L.
 - branchez Audio_R (RIN) sur OUT2_R et Audio_L (LIN) sur OUT2_L.
 - branchez la mise à terre (GND) sur mise à terre (GND).
 - MIC_RET et OUT_RET sont exclusivement réservés au panneau audio HD. Il est inutile de les brancher avec le panneau audio AC'97.
 - Pour activer le micro frontal, sélectionnez l'onglet « FrontMic » du panneau de contrôle Realtek et réglez le paramètre « Volume d'enregistrement ».

Embase du haut-parleur du châssis
(SPEAKER1 à 4 broches)
(voir p.1, No. 13)



Veuillez brancher le haut-parleur du châssis sur cette embase.

Connecteurs du châssis et de l'alimentation du ventilateur
(CHA_FAN1 à 4 broches)
(voir p.1, No. 4)

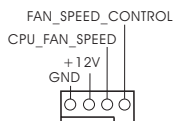

Veuillez brancher les câbles du ventilateur sur les connecteurs du ventilateur, puis reliez le fil noir à la broche de mise à terre.

Connecteurs du ventilateur du processeur
(CPU_FAN1 à 4 broches)
(voir p.1, No. 1)

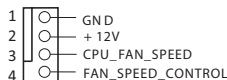

Cette carte mère est dotée d'un connecteur pour ventilateur de processeur (Quiet Fan) à 4 broches. Si vous envisagez de connecter un ventilateur de processeur à 3 broches, veuillez le brancher sur la Broche 1-3.

Connecteur
d'alimentation ATX
(ATXPWR1 à 24 broches)
(voir p.1, No. 5)

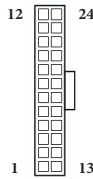

Cette carte mère est dotée d'un connecteur d'alimentation ATX à 24 broches. Pour utiliser une alimentation ATX à 20 broches, veuillez effectuer les branchements sur la Broche 1 et la Broche 13.

Connecteur
d'alimentation ATX 12V
(ATX12V1 à 8 broches)
(voir p.1, No. 2)

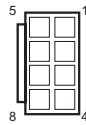

Cette carte mère est dotée d'un connecteur d'alimentation ATX 12V à 8 broches. Pour utiliser une alimentation ATX à 4 broches, veuillez effectuer les branchements sur la Broche 1 et la Broche 5.

Embase d'intrusion
châssis
(CII à 2 broches)
(voir p.1, No. 11)



Cette carte mère prend en charge la fonction de détection CHASSIS OUVERT qui alerte l'utilisateur en cas de retrait du boîtier du châssis. Cette fonction requiert un châssis à conception intégrant la détection d'intrusion.

Embase TPM
(TPMS1 à 17 broches)
(voir p.1, No. 10)

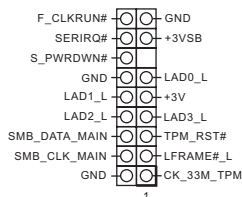

Ce connecteur prend en charge un module TPM (Trusted Platform Module – Module de plateforme sécurisée), qui permet de sauvegarder clés, certificats numériques, mots de passe et données en toute sécurité. Le système TPM permet également de renforcer la sécurité du réseau, de protéger les identités numériques et de préserver l'intégrité de la plateforme.

1 Introduzione

Grazie per aver acquistato la scheda madre Z87E-ITX ASRock, una scheda madre affidabile prodotta secondo i costanti e rigorosi controlli di qualità di ASRock.

La scheda madre offre eccellenti prestazioni con un design robusto che si adatta all'impegno di ASRock di offrire sempre qualità e durata.



Dato che le specifiche della scheda madre e del software BIOS possono essere aggiornate, il contenuto di questa documentazione sarà soggetto a variazioni senza preavviso. Nel caso di eventuali modifiche del presente manuale, la versione aggiornata sarà disponibile sul sito Web di ASRock senza ulteriore preavviso. Per il supporto tecnico correlato a questa scheda madre, visitare il nostro sito Web per informazioni specifiche relative al modello attualmente in uso. È possibile trovare l'elenco di schede VGA più recenti e di supporto di CPU anche sul sito Web di ASRock. Sito Web di ASRock <http://www.asrock.com>.

1.1 Contenuto della confezione

- Scheda madre Z87E-ITX ASRock (fattore di forma Mini-ITX)
- Guida rapida di installazione Z87E-ITX ASRock
- CD di supporto Z87E-ITX ASRock
- 4 x cavi dati Serial ATA (SATA) (opzionali)
- 1 x mascherina metallica posteriore I/O
- 1 x antenna WiFi da 2,4 GHz ASRock
- 1 x adattatore DVI-D-Sub

1.2 Specifiche

Piattaforma

- Fattore di forma Mini-ITX
- Design condensatore Premium Gold (condensatori a conduttore in polimero di alta qualità realizzati al 100% in Giappone)

CPU

- Supporta Intel® Core™ i7 / i5 / i3 di 4a generazione / Xeon® / Pentium® / Celeron® in LGA1150 Package
- Design Digi Power
- 6 Power Phase Design
- DrMOS
- Supporta la tecnologia Intel® Turbo Boost 2.0
- Supporta Intel® K-Series unlocked CPU

Chipset

- Intel® Z87

Memoria

- Tecnologia con memoria DDR3 a doppio canale
- 2 x slot DIMM DDR3
- Supporta memoria DDR3 2933+(OC)/2800(OC)/2400(OC)/2133(OC)/1866(OC)/1600/1333/1066 non ECC, senza buffer
- Capacità max. della memoria di sistema: 16GB (si veda la sezione ATTENZIONE)
- Supporta Intel® Extreme Memory Profile (XMP)1.3/1.2

Slot di espansione

- 1 x PCI Express 3.0 x16 slot
- 1 x slot half mini-PCI Express: per WiFi + modulo BT
- 1 x slot mSATA/full mini-PCI Express

Grafica

- La videografica integrata della scheda video HD Intel® e le uscite VGA possono essere supportate soltanto con processori con GPU integrata.
- Supporta la videografica integrata della scheda video HD Intel®: Intel® Quick Sync Video con AVC, MVC (S3D) e MPEG-2 Full HW Encode1, Intel® InTru™ 3D, tecnologia Intel® Clear Video HD, Intel® Insider™, Intel® HD Graphics 4400/4600
- Pixel Shader 5.0, DirectX 11.1
- Memoria condivisa max. 1792 MB

- Tre opzioni uscita VGA: DVI-I, HDMI e DisplayPort
- Supporta il tripla monitor
- Supporta la tecnologia HDMI con una risoluzione max. fino a 4 K x 2 K (4096 x 2304) a 24 Hz
- Supporta DVI-I con una risoluzione max. fino a 1920 x 1200 a 60 Hz
- Supporta DisplayPort con una risoluzione max. fino a 3840 x 2160 a 60 Hz
- Supporta Auto Lip Sync, Deep Color (12 bpc), xvYCC e HBR (High Bit Rate Audio) con HDMI (è necessario un monitor conforme ad HDMI)
- Supporta la funzione HDCP con porte DVI-I, HDMI e DisplayPort
- Supporta Blu-ray (BD) Full HD 1080p/riproduzione HD-DVD con porte DVI-I, HDMI e DisplayPort

Audio

- Audio HD a 7.1 canali con Content Protection (codec audio Realtek ALC1150)
- Supporto audio Blu-ray Premium
- TI® NE5532 (supporta l'amplificatore per cuffie di qualità superiore fino a 600 Ohm)
- Supporta DTS Connect

LAN

- LAN Gigabit 10/100/1000 Mb/s
- Giga PHY Intel® I217V
- Supporta la tecnologia Intel® Remote Wake
- Supporta Wake-On-LAN
- Supporta Energy Efficient Ethernet 802,3az
- Supporta PXE

LAN wireless

- Supporta IEEE 802.11a/b/g/n/ac
- Supporta Dual-Band (2,4/5 GHz)
- Supporta la connessione wireless ad alta velocità fino a 867 Mbps
- 2 antenne per supportare tecnologia a diversità 2 (trasmissione) x 2 (ricezione)
- Supporta Bluetooth 4.0/3.0 + classe II ad alta velocità

I/O pannello posteriore

- 1 x porta mouse/tastiera PS/2
- 1 x porta DVI-I
- 1 x porta HDMI
- 1 x DisplayPort
- 1 x porta uscita SPDIF ottico
- 1 x connettore eSATA
- 2 x porte USB 2.0
- 4 x porte USB 3.0
- 1 x porta LAN RJ-45 con LED (ACT/LINK LED e SPEED LED)
- 1 x interruttore per azzerare la CMOS
- Jack audio HD: altoparlante posteriore/centrale/basso/ingresso linea/altoparlante anteriore/microfono

Archiviazione

- 6 x connettori SATA3 6,0 Gb/s, supporto RAID (RAID 0, RAID 1, RAID 5, RAID 10, tecnologia Intel Rapid Storage 12 e tecnologia Intel Smart Response), NCQ, AHCI e “Hot Plug” (il connettore SATA3_5 è condiviso con la porta eSATA; il connettore SATA3_4 è condiviso con lo slot mSATA/mini-PCI Express)
- 1 x connettore eSATA, supporta le funzioni NCQ, AHCI e “Hot Plug”
- 1 x connettore mSATA 6,0 Gb/s (connettore Solid-State Drive), supporta le funzioni NCQ, AHCI e i moduli mini-PCI Express full size

Connettore

- 1 x header di intrusione nello chassis
- 1 x header TPM
- 1 x connettore ventola CPU (4 pin)
- 1 x connettore ventola chassis (4 pin)
- 1 x connettore alimentazione ATX a 24 pin
- 1 x connettore alimentazione da 12 V a 8 pin (connettore alimentazione ad alta densità)
- 1 x connettore audio pannello anteriore
- 2 x header USB 2.0 (supporto 4 porte USB 2.0)
- 1 x header USB 3.0 (supporta 2 porte USB 3.0)

Caratteristiche del BIOS

- BIOS legale 64 Mb AMI UEFI con supporto GUI multilingue
- Eventi di wake up conformi ad ACPI 1.1
- Supporto SMBIOS 2.3.1
- Multiregolazione tensione CPU, DRAM, PCH 1,05 V, PCH 1,5 V

CD di supporto

- Driver, Utilità, software antivirus (versione di prova), versione di prova di CyberLink MediaEspresso 6.5, browser e barra degli strumenti Google Chrome, Start8, MeshCentral, Splashtop Streamer, Intel® Extreme Tuning Utility (IXTU)

Hardware Monitor

- Sensore temperatura CPU/chassis
- Tachimetro CPU/chassis
- Ventola silenziosa CPU/chassis (consente l'autoregolazione della velocità della ventola dello chassis mediante la temperatura della CPU)
- Controllo multivelocità della ventola di CPU/chassis
- Monitoraggio tensione: +12 V, +5 V, +3,3 V, CPU Vcore

SO

- Microsoft® Windows® 8/8 a 64-bit/7/conforme a 7 a 64-bit

Certificazioni

- FCC, CE, WHQL
- ErP/EuP Ready (è necessaria alimentazione ErP/EuP ready)

* Per informazioni dettagliate sul prodotto, visitare il nostro sito Web: <http://www.asrock.com>



Prestare attenzione al potenziale rischio previsto nella pratica di overclocking, inclusa la regolazione delle impostazioni nel BIOS, l'applicazione di tecnologia di Untied Overclocking o l'utilizzo di strumenti di overclocking di terze parti. L'overclocking può influenzare la stabilità del sistema o perfino provocare danni ai componenti e ai dispositivi del sistema. Occorre eseguirlo a proprio rischio e spese. Non ci riterremo responsabili per possibili danni provocati da overclocking.



A causa della limitazione, l'effettiva dimensione della memoria può essere inferiore a 4 GB per riservare l'uso del sistema ai sistemi operativi di Windows® a 32 bit. I sistemi operativi Windows® a 64 bit non possiedono tali limitazioni. È possibile utilizzare la RAM XFast di ASRock per utilizzare la memoria che Windows® non può utilizzare.

1.3 Impostazione jumper

L'illustrazione mostra in che modo vengono impostati i jumper. Quando il cappuccio del jumper è posizionato sui pin, il jumper è "cortocircuitato". Se sui pin non è posizionato alcun cappuccio del jumper, il jumper è "aperto".

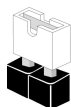

Short



Open

Jumper per azzerare la CMOS
(CLRCMOS1)
(vedere pag. 1, n. 14)



Jumper a 2 pin

Cortocircuitato: azzeramento della CMOS
Aperto: predefinito

CLRCMOS1 consente di azzerare i dati presenti nella CMOS. I dati presenti nella CMOS includono informazioni relative all'impostazione del sistema quali password del sistema, data, ora e parametri di impostazione del sistema. Per azzerare e reimpostare i parametri del sistema alla configurazione predefinita, spegnere il computer e scollegare il cavo di alimentazione, quindi utilizzare un cappuccio del jumper per cortocircuitare i pin su CLRCMOS1 per 3 secondi. Ricordarsi di rimuovere il cappuccio del jumper dopo aver azzerato la CMOS. Se è necessario azzerare la CMOS dopo l'aggiornamento del BIOS, è necessario riavviare prima il sistema e in seguito spegnerlo prima di eseguire l'operazione di azzeramento della CMOS.



1. L'interruttore di azzeramento della CMOS ha la stessa funzione del jumper per azzerare la CMOS.
2. Se si azzerano la CMOS, può essere rilevato il case aperto. Regolare l'opzione del BIOS "Azzerare stato" per azzerare il registro del precedente stato di intrusione nello chassis.

1.4 Header e connettori sulla scheda



Gli header e i connettori sulla scheda **NON** sono jumper. **NON** posizionare cappucci del jumper su questi header e connettori. Il posizionamento di cappucci del jumper su header e connettori provocherà danni permanenti alla scheda madre.

Header sul pannello del sistema
(PANEL1 a 9 pin)
(vedere pag. 1, n. 12)

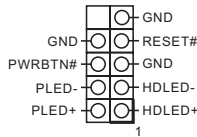

Collegare l'interruttore dell'alimentazione, l'interruttore di reset e l'indicatore dello stato del sistema sullo chassis su questo header secondo la seguente assegnazione dei pin. Annotare i pin positivi e negativi prima di collegare i cavi.



PWRBTN (interruttore alimentazione):

collegare all'interruttore dell'alimentazione sul pannello anteriore dello chassis. È possibile configurare il modo in cui spegnere il sistema utilizzando l'interruttore dell'alimentazione.

RESET (interruttore di reset):

collegare all'interruttore di reset sul pannello anteriore dello chassis. Premere l'interruttore di reset per riavviare il computer se il computer si blocca e non riesce ad eseguire un normale riavvio.

PLED (LED alimentazione del sistema):

collegare all'indicatore di stato dell'alimentazione sul pannello anteriore dello chassis. Il LED è acceso quando il sistema è in funzione. Il LED continua a lampeggiare quando il sistema si trova nello stato di sospensione S1/S3. Il LED è spento quando il sistema si trova nello stato di sospensione S4 o quando è spento (S5).

HDLED (LED di attività disco rigido):

collegare al LED di attività disco rigido sul pannello anteriore dello chassis. Il LED è acceso quando il disco rigido sta leggendo o scrivendo dati.

Il design del pannello anteriore può cambiare a seconda dello chassis. Un modulo di pannello anteriore è composto principalmente da interruttore di alimentazione, interruttore di reset, LED di alimentazione, LED di attività disco rigido, altoparlante, ecc. Quando si collega il modulo del pannello anteriore dello chassis a questo header, accertarsi che le assegnazioni del filo e le assegnazioni del pin corrispondano correttamente.

Connettori Serial ATA3

(SATA3_0:
vedere pag.1, n. 16)
(SATA3_1:
vedere pag.1, n. 15)
(SATA3_2:
vedere pag.1, n. 17)
(SATA3_3:
vedere pag.1, n. 9)
(SATA3_4:
vedere pag.1, n. 8)
(SATA3_5:
vedere pag.1, n. 6)



Questi sei connettori SATA3 supportano cavi dati SATA per dispositivi di archiviazione interna, con una velocità di trasferimento dati fino a 6,0 Gb/s. Il connettore SATA3_5 è condiviso con la porta eSATA; il connettore SATA3_4 è condiviso con lo slot mSATA/mini-PCIE.

Header USB 2.0

(USB_2_3 a 9 pin)
(vedere pag. 1, n. 21)
(USB_4_5 a 9 pin)
(vedere pag. 1, n. 20)

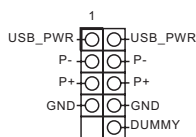

Oltre alle due porte USB 2.0 sul pannello I/O, su questa scheda madre vi sono due header. Ciascun header USB 2.0 può supportare due porte.

Header USB 3.0

(USB3_5_6 a 19 pin)
(vedere pag. 1, n. 7)

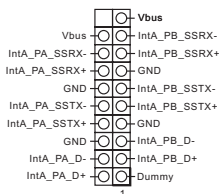

Oltre alle quattro porte USB 3.0 sul pannello I/O, su questa scheda madre vi è un header. Ciascun header USB 3.0 può supportare due porte.

Header audio pannello anteriore

(AUDIO1_HD a 9 pin)
(vedere pag. 1, n. 21)

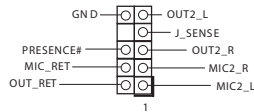

Questo header serve a collegare i dispositivi audio al pannello audio anteriore.



1. L'audio ad alta definizione supporta le funzioni Jack sensing, ma il filo del pannello sullo chassis deve supportare HDA per funzionare correttamente. Seguire le istruzioni presenti nel nostro manuale e nel manuale dello chassis per installare il sistema.
2. Se si utilizza un pannello audio AC'97, installarlo sull'header audio del pannello anteriore seguendo le fasi di seguito:
 - A. Collegare Mic_IN (MIC) a MIC2_L.
 - B. Collegare Audio_R (RIN) a OUT2_R e Audio_L (LIN) a OUT2_L.
 - C. Collegare Ground (GND) a Ground (GND).
 - D. MIC_RET e OUT_RET servono soltanto per il pannello audio HD. Non è necessario collegarli per il pannello audio AC'97.
 - E. Per attivare il microfono anteriore, andare alla scheda "MicAnt" nel pannello di controllo Realtek e regolare il "Volume di registrazione".

Header altoparlante chassis

(SPEAKER1 a 4 pin)
(vedere pag. 1, n. 13)

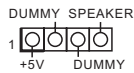

Collegare l'altoparlante dello chassis a questo header.

Connettori ventola dello chassis e di alimentazione

(CHA_FAN1 a 4 pin)
(vedere pag. 1, n. 4)

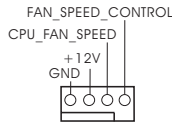

Collegare i cavi della ventola ai connettori della ventola e far corrispondere il filo nero al pin di terra.

Connettori della ventola della CPU

(CPU_FAN1 a 4 pin)
(vedere pag. 1, n. 1)

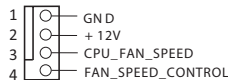

Questa scheda madre è dotata di un connettore per la ventola della CPU (Ventola silenziosa) a 4 pin. Se si decide di collegare una ventola della CPU a 3 pin, collegarla al pin 1-3.

Connettore di alimentazione ATX (ATXPWR1 a 24 pin) (vedere pag. 1, n. 5)

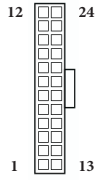

Questa scheda madre è dotata di un connettore di alimentazione ATX a 24 pin. Per utilizzare un'alimentazione ATX a 20 pin, collegarla lungo il pin1 e il pin 13.

Connettore di alimentazione ATX da 12 V (ATX12V1 a 8 pin) (vedere pag. 1, n. 2)

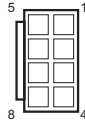

Questa scheda madre è dotata di un connettore di alimentazione ATX da 12 V a 8 pin. Per utilizzare un'alimentazione ATX a 4 pin, collegarla lungo il pin1 e il pin 5.

Header di intrusione nello chassis (CII1 a 2 pin) (vedere pag. 1, n. 11)



Questa scheda madre supporta la caratteristica di rilevamento CASE OPEN che rileva che il coperchio del case è stato rimosso. Questa funzione richiede uno chassis con caratteristiche di rilevamento di intrusione nello chassis.

Header TPM (TPMS1 a 17 pin) (vedere pag. 1, n. 10)

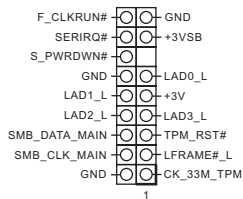

Questo connettore supporta il sistema Trusted Platform Module (TPM), che può archiviare in modo sicuro chiavi, certificati digitali, password e dati. Un sistema TPM permette anche di potenziare la sicurezza della rete, di proteggere identità digitali e di garantire l'integrità della piattaforma.

1 Introducción

Gracias por comprar la placa base ASRock Z87E-ITX, una placa base fiable fabricada según el rigurosísimo control de calidad de ASRock. Ofrece un rendimiento excelente con un diseño resistente de acuerdo con el compromiso de calidad y resistencia de ASRock.



Ya que las especificaciones de la placa base y el software del BIOS podrán ser actualizados, el contenido que aparece en esta documentación estará sujeto a modificaciones sin previo aviso. Si este manual sufre alguna modificación, la versión actualizada estará disponible en el sitio web de ASRock sin previo aviso. Si necesita asistencia técnica relacionada con esta placa base, visite nuestro sitio web para obtener información específica sobre el modelo que esté utilizando. Podrá encontrar las últimas tarjetas VGA, así como la lista de compatibilidad de la CPU, en el sitio web de ASRock. Sitio web de ASRock <http://www.asrock.com>.

1.1 Contenido del paquete

- Placa base ASRock Z87E-ITX (Factor de forma Mini-ITX)
- Guía de instalación rápida de ASRock Z87E-ITX
- CD de soporte de ASRock Z87E-ITX
- 4 cables de datos Serie ATA (SATA) (Opcional)
- 1 escudo panel I/O
- 1 antena WiFi ASRock de 2,4GHz
- 1 convertidor de DVI a D-Sub

1.2 Especificaciones

- Plataforma**
- Factor de forma Mini-ITX
 - Diseño de los Condensadores: Premium Gold (Condensadores de polímero conductor, de alta calidad, 100% fabricados en Japón)

- CPU**
- Compatible con 4.ª Generación de Intel® Core™ i7 / i5 / i3 / Xeon® / Pentium® / Celeron® en paquete LGA1150
 - Diseño Digi Power
 - Diseño de 6 fases de alimentación
 - DrMOS
 - Compatible con la Tecnología de Intel® Turbo Boost 2.0
 - Compatible con CPU serie K desbloqueada de Intel®

- Conjunto de chips**
- Intel® Z87

- Memoria**
- Tecnología de memoria de Doble Canal DDR3
 - 2 ranuras DDR3 DIMM
 - Compatible con memoria no-ECC, sin búfer DDR3 2933+(OC)/2800(OC)/2400(OC)/2133(OC)/1866(OC)/1600/1333/1066
 - Capacidad máxima de la memoria del sistema: 16GB (consulte la ADVERTENCIA)
 - Compatible con Extreme Memory Profile (XMP)1.3/1.2 de Intel®

- Ranura de expansión**
- 1 ranura PCI Express 3.0 x16
 - 1 ranura Express media mini-PCI: para WiFi + módulo BT
 - 1 ranura Express mini-PCI mSATA/completa

- Gráficos**
- La Tecnología visual integrada de gráficos HD de Intel® y las salidas de VGA son compatibles únicamente con procesadores con GPU integrado.
 - Compatible con la Tecnología visual integrada de gráficos HD de Intel®: Intel® Quick Sync Video con AVC, MVC (S3D) y MPEG-2 Full HW Encode1, Intel® InTru™ 3D, Intel® Clear Video HD Technology, Intel® Insider™, Intel® HD Graphics 4400/4600
 - Pixel Shader 5.0, DirectX 11.1
 - Memoria compartida máxima: 1792MB

- Tres opciones de salida VGA: DVI-I, HDMI y DisplayPort
- Compatible con monitores triples
- Compatible con Tecnología HDMI con máxima resolución hasta 4K × 2K (4096x2304) @ 24Hz
- Compatible con DVI-I con máxima resolución hasta 1920x1200 @ 60Hz
- Compatible con DisplayPort con máxima resolución hasta 3840x2160 @ 60Hz
- Compatible con Auto Lip Sync, Deep Color (12bpc), xvYCC y HBR (audio de alta velocidad de bits) con HDMI (requiere un monitor compatible con HDMI)
- Compatible con función HDCP con puertos DVI-I, HDMI y DisplayPort
- Compatible con reproducción Blu-ray (BD) Full HD de 1080p / HD-DVD con puertos DVI-I, HDMI y DisplayPort

Audio

- 7.1 Audio CH HD con Protección de contenido (Realtek ALC1150 Audio Codec)
- Compatible con audio Blu-ray Premium
- TI® NE5532 (compatible con Amplificador de Auriculares Premium de hasta 600 ohmios)
- Compatible con DTS Connect

LAN

- LAN Gigabit 10/100/1000 Mb/s
- Giga PHY Intel® I217V
- Compatible con la Tecnología Remote Wake de Intel®
- Compatible con Wake-On-LAN
- Compatible con Ethernet de consumo eficiente de energía 802.3az
- Compatible con PXE

LAN inalámbrica

- Compatible con IEEE 802.11a/b/g/n/ac
- Compatible con Banda Dual (2,4/5 GHz)
- Compatible con conexión inalámbrica de alta velocidad hasta 867Mbps
- 2 antenas compatibles con Tecnología de diversidad 2 (Transmisión) x 2 (Recepción)
- Compatible con Bluetooth 4.0 / 3.0 + Alta velocidad clase II

Panel trasero I/O

- 1 puerto de ratón/teclado PS/2
- 1 puerto DVI-I
- 1 puerto HDMI
- 1 DisplayPort
- 1 puerto de salida SPDIF óptica
- 1 conector eSATA
- 2 puertos USB 2.0
- 4 puertos USB 3.0
- 1 puerto LAN RJ-45 con LED (ACT/LINK LED y SPEED LED)
- 1 interruptor de borrado CMOS
- Conector de audio HD: Altavoz trasero / Central / Graves / Entrada de línea / Altavoz frontal / Micrófono

Almacenamiento

- Los 6 conectores SATA3 de 6,0 Gb/s, compatibles con RAID (RAID 0, RAID 1, RAID 5, RAID 10, Tecnología Rapid Storage 12 de Intel y Tecnología Smart Response de Intel), NCQ, AHCI y “Hot Plug” (el conector SATA3_5 se comparte con el puerto eSATA; el conector SATA3_4 se comparte con la ranura Express mSATA/mini-PCI)
- 1 conector eSATA, compatible con las funciones NCQ, AHCI y “Hot Plug”
- 1 conector mSATA de 6,0 Gb/s (conector Solid-State Drive), compatible con las funciones NCQ, AHCI y los módulos Express mini-PCI de tamaño completo

Conectores

- 1 cabezal de intrusión de chasis
- 1 cabezal TPM
- 1 conector de ventilador de la CPU (de 4 pines)
- 1 conector de ventilador de chasis (de 4 pines)
- 1 conector de alimentación ATX de 24 pines
- 1 conector de alimentación de 8 pines y 12V (conector de alimentación de alta densidad)
- 1 conector de audio del panel frontal
- 2 cabezales USB 2.0 (compatibles con 4 puertos USB 2.0)
- 1 cabezal USB 3.0 (compatible con 2 puertos USB 3.0)

Características del BIOS

- BIOS legal UEFI AMI de 64Mb compatible con interfaz gráfica de usuario multilingüe
- Eventos de reactivación conformes con ACPI 1.1
- Compatible con SMBIOS 2.3.1
- Multiajuste de voltaje de CPU, DRAM, PCH 1,05V, PCH 1,5V

CD de soporte

- Controladores, Utilidades, Software AntiVirus (Versión de prueba), Versión de prueba de CyberLink MediaEspresso 6.5, Explorador y Barra de herramientas de Google Chrome, Start8, MeshCentral, Splashtop Streamer y Intel® Extreme Tuning Utility (IXTU)

Monitor del hardware

- Método de sensor de temperatura de la CPU/Chasis
- Tacómetro de la CPU/Chasis
- Ventilador silencioso de la CPU/Chasis (permite ajustar automáticamente la velocidad del ventilador del chasis mediante la temperatura de la CPU)
- Control multivelocidad del ventilador de la CPU/Chasis
- Control del voltaje: +12V, +5V, +3,3V, CPU Vcore

SO

- Compatible con Microsoft® Windows® 8 / 8 de 64 bits / 7 / 7 de 64 bits

Certificaciones

- FCC, CE, WHQL
- Compatible con ErP/EuP (requiere toma de alimentación compatible con ErP/EuP)

* Para obtener más información acerca del producto, visite nuestro sitio web: <http://www.asrock.com>



Tenga en cuenta que existen ciertos riesgos relacionados con el overlocking (sobreceleración), incluyendo el ajuste de la configuración del BIOS, aplicando la Tecnología overlocking no vinculada o utilizando las herramientas de overlocking de tercera parte. El overlocking podría afectar la estabilidad de su sistema o incluso dañar los componentes y dispositivos de su sistema. Si lo realiza, todos los riesgos y gastos derivados del overlocking serán de su entera responsabilidad. No nos hacemos responsables de posibles daños producidos por el overlocking.



Debido a las limitaciones, el tamaño real de la memoria podrá ser inferior a 4GB para reservar espacio para el uso del sistema en sistemas operativos Windows® de 32 bits. Los sistemas operativos Windows® de 64 bits no tienen estas limitaciones. Podrá utilizar XFast RAM de ASRock para usar la memoria que Windows® no puede utilizar.

1.3 Instalación de los puentes

La instalación muestra cómo deben instalarse los puentes. Cuando la tapa de puente se coloca en los pines, el puente queda “Corto”. Si no coloca la tapa de puente en los pines, el puente queda “Abierto”.

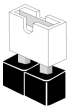

Short



Open

Puente de borrado de CMOS
(CLR CMOS1)

(consulte la pág.1, N.º 14)



Puente de 2 pines

Corto: Borrado de CMOS

Abierto: Predeterminado

CLR CMOS1 le permite borrar los datos del CMOS. Los datos del CMOS incluyen información de instalación del sistema como, por ejemplo, la contraseña, la fecha y la hora del sistema y los parámetros de instalación del sistema. Para borrar y restablecer los parámetros del sistema a los valores predeterminados de instalación, apague el ordenador y desenchufe el cable de alimentación. A continuación, utilice una tapa de puente para acortar los pines del CLR CMOS1 durante 3 segundos. Acuérdesse de retirar la tapa de puente después de borrar el CMOS. Si necesita borrar el CMOS cuando acabe de actualizar el BIOS, deberá arrancar el sistema primero y, a continuación, deberá apagarlo antes de que realice el borrado del CMOS.



1. El interruptor de borrado CMOS tiene la misma función que el puente de borrado de CMOS.
2. Si borra el CMOS, podrá detectarse la cubierta abierta. Ajuste la opción del BIOS “Clear Status” (Borrar estado) para borrar el registro del estado de intrusión anterior del chasis.

1.4 Conectores y cabezales incorporados



Los cabezales y conectores incorporados NO son puentes. NO coloque tapas de puente sobre estos cabezales y conectores. Si coloca tapas de puente sobre los cabezales y conectores dañará de forma permanente la placa base.

Cabezal del panel del sistema
(PANEL1 de 9 pines)
(consulte la pág.1, N.º 12)

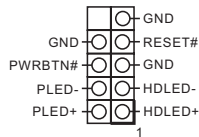

Conecte el interruptor de alimentación, restablezca el interruptor y el indicador del estado del sistema del chasis a los valores de este cabezal, según los valores asignados a los pines como se indica a continuación. Cerciórese de cuáles son los pines positivos y los negativos antes de conectar los cables.



PWRBTN (Interruptor de alimentación):

conéctelo al interruptor de alimentación del panel frontal del chasis. Deberá configurar la forma en la que su sistema se apagará mediante el interruptor de alimentación.

RESET (Interruptor de reseteo):

conéctelo al interruptor de reseteo del panel frontal del chasis. Pulse el interruptor de reseteo para resetear el ordenador si éste está bloqueado y no se puede reiniciar de forma normal.

PLED (Indicador LED de alimentación del sistema):

conéctelo al indicador del estado de la alimentación del panel frontal del chasis. El indicador LED permanece encendido cuando el sistema está funcionando. El indicador LED parpadea cuando el sistema se encuentra en estado de suspensión S1/S3. El indicador LED se apaga cuando el sistema se encuentra en estado de suspensión S4 o está apagado (S5).

HDLED (Indicador LED de actividad en el disco duro):

conéctelo al indicador LED de actividad en el disco duro del panel frontal del chasis. El indicador LED permanece encendido cuando el disco duro está leyendo o escribiendo datos.

El diseño del panel frontal puede ser diferente dependiendo del chasis. Un módulo de panel frontal consta principalmente de: interruptor de alimentación, interruptor de reseteo, indicador LED de alimentación, indicador LED de actividad en el disco duro, altavoz, etc. Cuando conecte su módulo del panel frontal del chasis a este cabezal, asegúrese de que las asignaciones de los cables y los pines coinciden correctamente.

Conectores Serie ATA3

(SATA3_0:
consulte la pág.1, N.º 16)
(SATA3_1:
consulte la pág.1, N.º 15)
(SATA3_2:
consulte la pág.1, N.º 17)
(SATA3_3:
consulte la pág.1, N.º 9)
(SATA3_4:
consulte la pág.1, N.º 8)
(SATA3_5:
consulte la pág.1, N.º 6)

SATA3_5



SATA3_4



SATA3_3



SATA3_2



SATA3_1



SATA3_0



Estos seis conectores SATA3 son compatibles con cables de datos SATA para dispositivos de almacenamiento interno con una velocidad de transferencia de datos de hasta 6,0 Gb/s. El conector SATA3_5 se comparte con el puerto eSATA y el conector SATA3_4 se comparte con la ranura mSATA/mini-PCIe.

Cabezales USB 2.0

(USB_2_3 de 9 pines)
(consulte la pág.1, N.º 21)
(USB_4_5 de 9 pines)
(consulte la pág.1, N.º 20)

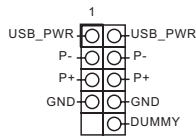

Además de dos puertos USB 2.0 en el panel I/O, esta placa base contiene dos cabezales. Cada cabezal USB 2.0 admite dos puertos.

Cabezales USB 3.0

(USB3_5_6 de 19 pines)
(consulte la pág.1, N.º 7)

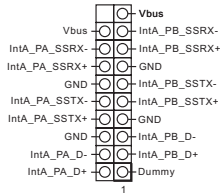

Además de cuatro puertos USB 3.0 en el panel I/O, esta placa base contiene un cabezal. Cada cabezal USB 3.0 admite dos puertos.

Cabezal de audio del panel frontal
(HD_AUDIO1 de 9 pines)
(consulte la pág.1, N.º 21)

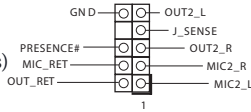

Este cabezal se utiliza para conectar dispositivos de audio al panel de audio frontal.



1. El Audio de Alta Definición (HDA, en inglés) es compatible con el método de sensor de conectores, sin embargo, el cable del panel del chasis deberá ser compatible con HDA para que pueda funcionar correctamente. Siga las instrucciones que se indican en nuestro manual y en el manual del chasis para instalar su sistema.
2. Si utiliza un panel de audio AC'97, instálelo en el cabezal de audio del panel frontal siguiendo los siguientes pasos:
 - A. Conecte Mic_IN (MIC) a MIC2_L.
 - B. Conecte Audio_R (RIN) a OUT2_R y Audio_L (LIN) a OUT2_L.
 - C. Conecte Ground (conexión a tierra) (GND) a Ground (GND).
 - D. MIC_RET y OUT_RET se utilizan únicamente para el panel de audio HD. No es necesario que los conecte en el panel de audio AC'97.
 - E. Para activar el micrófono frontal, vaya a la ficha "micrófono frontal" (FrontMic) en el panel de control de Realtek y ajuste el "Volumen de grabación" (Recording Volume).

Cabezal de altavoces del chasis
(SPEAKER1 de 4 pines)
(consulte la pág.1, N.º 13)

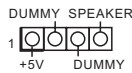

Conecte el altavoz del chasis a este cabezal.

Conectores del ventilador de alimentación y del chasis
(CHA_FAN1 de 4 pines)
(consulte la pág.1, N.º 4)

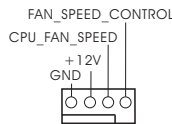

Conecte los cables del ventilador a los conectores del ventilador y haga coincidir el cable negro con el pin de conexión a tierra.

Conectores del ventilador de la CPU
(CPU_FAN1 de 4 pines)
(consulte la pág.1, N.º 1)

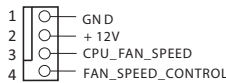

Esta placa base contiene un conector de ventilador (ventilador silencioso) de CPU de 4 pines. Si tiene pensando conectar un ventilador de CPU de 3 pines, conéctelo al Pin 1-3.

Conector de alimentación ATX
(ATXPWR1 de 24 pines)
(consulte la pág.1, N.º 5)

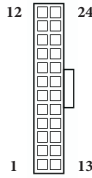

Esta placa base contiene un conector de alimentación ATX de 24 pines. Para utilizar una toma de alimentación ATX de 20 pines, conéctela en los Pines del 1 al 13.

Conector de alimentación ATX de 12V
(ATX12V1 de 8 pines)
(consulte la pág.1, N.º 2)

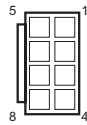

Esta placa base contiene un conector de alimentación ATX de 12V y 8 pines. Para utilizar una toma de alimentación ATX de 4 pines, conéctela en los Pines del 1 al 5.

Cabezal de intrusión de chasis
(CII de 2 pines)
(consulte la pág.1, N.º 11)



Esta placa base es compatible con la función de detección de CUBIERTA ABIERTA que detecta si se ha retirado la cubierta del chasis. Esta función requiere un chasis diseñado para la detección de intrusión del chasis.

Cabezal TPM
(TPMS1 de 17 pines)
(consulte la pág.1, N.º 10)

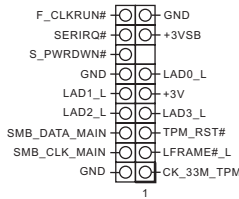

Este conector es compatible con el sistema Módulo de Plataforma Segura (TPM, en inglés), que puede almacenar de forma segura claves, certificados digitales, contraseñas y datos. Un sistema TPM también ayuda a aumentar la seguridad en la red, protege las identidades digitales y garantiza la integridad de la plataforma.

1 Введение

Благодарим вас за приобретение надежной материнской платы ASRock Z87E-ITX, выпускаемой под постоянным строгим контролем компании ASRock. Эта материнская плата обеспечивает великолепную производительность и характеризуется прочной конструкцией в соответствии с требованиями компании ASRock в отношении качества и долговечности.



По причине обновления спецификации на материнскую платформу и программного обеспечения BIOS содержимое настоящей документации может быть изменено без предварительного уведомления. При изменении содержимого настоящего руководства его обновленная версия будет доступна на веб-сайте ASRock без предварительного уведомления. При необходимости технической поддержки, связанной с материнской платой, посетите веб-сайт и найдите на нем информацию о модели используемой вами материнской платы. На веб-сайте ASRock также можно найти самый последний перечень поддерживаемых VGA-карт и ЦП. Веб-сайт ASRock <http://www.asrock.com>.

1.1 Комплект поставки

- Материнская плата ASRock Z87E-ITX (форм-фактор Mini-ITX)
- Краткое руководство по установке ASRock Z87E-ITX
- Диск с ПО для ASRock Z87E-ITX
- 4 x кабеля передачи данных Serial ATA (SATA) (приобретаются отдельно)
- 1 x экран панели с портами ввода-вывода
- 1 x WiFi-антенна ASRock 2,4 ГГц
- 1 x адаптер DVI/D-Sub

1.2 Спецификация

Платформа	<ul style="list-style-type: none"> • Форм-фактор Mini-ITX • Конструкция Premium Gold Capacitor (с использованием высококачественных конденсаторов из проводящих полимеров производства Японии)
ЦП	<ul style="list-style-type: none"> • Поддержка процессоров 4-го поколения Intel® Core™ i7 / i5 / i3 / Xeon® / Pentium® / Celeron® в исполнении LGA1150 • Digi Power Design • Система питания 6 • DrMOS • Поддержка технологии Intel® Turbo Boost 2.0 • Поддержка процессоров Intel® серии К с разблокированным множителем
Чипсет	<ul style="list-style-type: none"> • Intel® Z87
Память	<ul style="list-style-type: none"> • Двухканальная память DDR3 • 2 x гнездо DDR3 DIMM • Поддержка модулей памяти DDR3 2933+(OC)/2800(OC)/2400(OC)/2133(OC)/1866(OC)/1600/1333/1066 Non-ECC Unbuffered • Максимальный объем системной памяти: 16 Гб (см. «ПРЕДОСТЕРЕЖЕНИЕ») • Поддержка Intel® Extreme Memory Profile (XMP)1.3/1.2
Гнезда расширения	<ul style="list-style-type: none"> • 1 x PCI Express 3.0 x16 • 1 x PCI Express Half-Mini: Для модуля WiFi + BT • 1 x mSATA/PCI Express Full-Mini
Графическая система	<ul style="list-style-type: none"> • Поддержка выходных сигналов Intel® HD Graphics Built-in Visuals и VGA возможна только при использовании процессоров со встроенными графическими процессорами. • Поддержка Intel® HD Graphics Built-in Visuals: Intel® Quick Sync Video с AVC, MVC (S3D) и MPEG-2 Full HW Encode1, Intel® InTru™ 3D, Intel® Clear Video HD Technology, Intel® Insider™, Intel® HD Graphics 4400/4600 • Pixel Shader 5.0, DirectX 11.1 • Максимальный объем совместно используемой памяти: 1792 Мб

- Три выхода VGA: DVI-I, HDMI и DisplayPort
- Поддержка работы с тремя мониторами
- Поддержка технологии HDMI с максимальным разрешением до 4K × 2K (4096x2304) при 24 Гц
- Поддержка DVI-I с максимальным разрешением до 1920x1200 при 60 Гц
- Поддержка DisplayPort с максимальным разрешением до 3840x2160 при 60 Гц
- Поддержка Auto Lip Sync, Deep Color (12bpc), xvYCC и HBR (High Bit Rate Audio) по HDMI (необходим HDMI-совместимый монитор)
- Поддержка функции HDCP через порты DVI-I, HDMI и DisplayPort
- Поддержка воспроизведения Full HD 1080p Blu-ray (BD) / HD-DVD через порты DVI-I, HDMI и DisplayPort

Аудио

- 7.1-канальный звук высокой четкости HD Audio с защитой данных (аудиокодек Realtek ALC1150)
- Поддержка Premium Blu-ray Audio
- TI® NE5532 (поддержка усилителя Premium Headset Amplifier до 600 Ом)
- Поддержка DTS-подключения

ЛВС

- Gigabit LAN 10/100/1000 Мб/с
- Giga PHY Intel® I217V
- Поддержка технологии Intel® Remote Wake Technology
- Поддержка Wake-On-LAN
- Поддержка Energy Efficient Ethernet 802.3az
- Поддержка PXE

Беспроводная

ЛВС

- Поддержка IEEE 802.11a/b/g/n/ac
- Поддержка двух диапазонов (2,4/5 ГГц)
- Поддержка высокоскоростного беспроводного подключения до 867 Мбит/с
- 2 антенны для поддержки технологии передачи данных «2 (передача) x 2 (прием)»
- Поддержка Bluetooth 4.0 / 3.0 + High speed class II

Порты ввода-вывода на задней панели

- 1 x PS/2 для мыши/клавиатуры
- 1 x DVI-I
- 1 x HDMI
- 1 x DisplayPort
- 1 x оптический выходной SPDIF
- 1 x eSATA
- 2 x USB 2.0
- 4 x USB 3.0
- 1 x RJ-45 для ЛВС с СИД (СИД АСТ/LINK и МИД SPEED)
- 1 x переключатель сброса настроек CMOS
- Разъемы HD Audio: задние динамики / центральный динамик / сабвуфер / линейный вход / передние динамики / микрофон

Запоминающие устройства

- 6 x разъем SATA3 6,0 Гб/с, поддержка RAID (RAID 0, RAID 1, RAID 5, RAID 10, Intel Rapid Storage Technology 12 и Intel Smart Response Technology), NCQ, AHCI и «горячая» замена (разъем SATA3_5 используется совместно с портом eSATA; разъем SATA3_4 используется совместно с гнездом mSATA/PCI Express Mini)
- 1 x разъем eSATA, поддержка функций NCQ, AHCI и «горячей» замены
- 1 x разъем mSATA 6,0 Гб/с (разъем для твердотельного накопителя), поддержка функций NCQ, AHCI и модулей PCI Express Full-Mini

Разъемы

- 1 x колодка для датчика вскрытия корпуса
- 1 x колодка TPM
- 1 x разъем для вентилятора ЦП (4-контактный)
- 1 x разъем для вентилятора корпуса (4-контактный)
- 1 x разъем питания ATX (24-контактный)
- 1 x разъем питания 12 В (8-контактный) (разъем High Density Power Connector)
- 1 x аудиоразъем на передней панели
- 2 x колодки USB 2.0 (поддержка 4 портов USB 2.0)
- 1 x колодка USB 3.0 (поддержка 2 портов USB 3.0)

- Особенности BIOS**
- 64 Мб AMI UEFI Legal BIOS с поддержкой многоязычного ГИП
 - Совместимость с управлением энергопотреблением по ACPI 1.1
 - Поддержка SMBIOS 2.3.1
 - Регулировка напряжений ЦП, DRAM, PCN 1,05 В, PCN 1,5 В

- Диск с ПО**
- Драйвера, утилиты, антивирусное ПО (демоверсия), CyberLink MediaEspresso 6.5 (демоверсия), браузер и панель инструментов Google Chrome, Start8, MeshCentral, SplashTop Streamer, Intel® Extreme Tuning Utility (XTU)

- Контроль оборудования**
- Датчик температуры ЦП/корпуса
 - Тахометр вентиляторов ЦП/корпуса
 - Малошумящий вентилятор ЦП/корпуса (с автоматической регулировкой оборотов по температуре ЦП)
 - Управление оборотами вентилятора ЦП/корпуса
 - Контроль напряжения: +12 В, +5 В, +3,3 В, ЦП Vcore

- ОС**
- Microsoft® Windows® 8 / 8 64-разрядная / 7 / 7 64-разрядная

- Сертификация**
- FCC, CE, WHQL
 - Совместимость с ErP/EuP (необходим блок питания, соответствующий стандарту ErP/EuP)

* Для получения дополнительной информации об изделии посетите наш веб-сайт:
<http://www.asrock.com>



Следует учитывать, что разгон процессора, включая изменение настроек BIOS, применение технологии Untied Overclocking Technology и использование инструментов разгона независимых производителей, сопряжен с определенным риском. Разгон процессора может повлиять на стабильность системы или даже привести к повреждению ее компонентов и устройств. Вы выполняете разгон процессора на ваш собственный риск и за свой счет. Мы не несем ответственность за возможный ущерб, вызванный разгоном процессора.



В связи с ограничением при работе под 32-разрядной ОС Windows® фактический объем памяти может быть меньше 4 Гбайт. Для 64-разрядных ОС Windows® таких ограничений нет. Для использования той памяти, которую ОС Windows® не может использовать, используйте ASRock XFast RAM.

1.3 Установка перемычек

Установка перемычек показана на рисунке. При установке колпачковой перемычки на контакты перемычка «замкнута». Если колпачковая перемычка на контакты не установлена, перемычка «разомкнута».

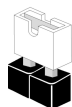

Short



Open

Перемычка сброса
настроек CMOS
(CLRCMOS1)
(См. стр. 1, № 14)



2-контактная перемычка

Замкнута: Сброс настроек
CMOS а
Разомкнута: по умолчанию

CLRCMOS1 используется для удаления данных CMOS. Данные CMOS включают в себя такую информацию о настройке системы, как системный пароль, дата, время и параметры настройки системы. Чтобы сбросить и обнулить параметры системы на настройки по умолчанию, выключите компьютер и извлеките вилку из розетки, а затем колпачковой перемычкой замкните контакты на CLRCMOS1 на 3 секунды. После сброса настроек CMOS не забудьте снять колпачковую перемычку. При необходимости сбросить настройки CMOS сразу после обновления BIOS сначала перезагрузите систему, а затем выключите компьютер перед сбросом настроек CMOS.



1. *Предназначение переключателя сброса настроек CMOS аналогично предназначению перемычки сброса настроек CMOS.*
2. *Сброс настроек CMOS может привести к определению вскрытия корпуса. Чтобы обнулить запись предыдущего определения вскрытия корпуса, используйте параметр Clear Status (Обнулить состояние) BIOS.*

1.4 Колодки и разъемы, расположенные на материнской плате



Расположенные на материнской плате колодки и разъемы перемычками НЕ являются. НЕ устанавливайте на эти колодки и разъемы колпачковые перемычки. Установка колпачковых перемычек на эти колодки и разъемы может вызвать неустранимое повреждение материнской платы.

Колодка системной панели
(9-контактная, PANEL1)
(См. стр. 1, № 12)

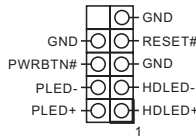

Подключите расположенные на корпусе выключатель питания, кнопку перезагрузки и индикатор состояния системы к этой колодке в соответствии с распределением контактов, приведенным ниже. Перед подключением кабелей определите положительный и отрицательный контакты.



PWRBTN (кнопка питания):

Подключение кнопки питания, расположенной на передней панели корпуса. Можно настроить порядок выключения системы с использованием кнопки питания.

RESET (кнопка перезагрузки):

Подключение кнопки перезагрузки системы, расположенной на передней панели корпуса. Нажмите кнопку перезагрузки, чтобы перезапустить компьютер, если он завис и нормальный запуск невозможен.

PLED (светодиодный индикатор питания системы):

Подключение индикатора состояния, расположенного на передней панели корпуса. Светодиодный индикатор горит, когда система работает. Когда система находится в режиме ожидания S1/S3, светодиод мигает. Когда система находится в режиме ожидания S4 или выключена (S5), светодиод не горит.

HDLED (светодиодный индикатор работы жесткого диска):

Подключение светодиодного индикатора работы жесткого диска, расположенного на передней панели корпуса. Светодиодный индикатор горит, когда жесткий диск выполняет считывание или запись данных.

Передняя панель может быть разной на разных корпусах. В основном передняя панель включает в себя кнопку питания, кнопку перезагрузки, светодиодный индикатор питания, светодиодный индикатор работы жесткого диска, динамик и т. д. При подключении передней панели к этой колодке правильно подключайте провода к контактам.

Разъемы Serial ATA3

- (SATA3_0:
см. стр.1, № 16)
- (SATA3_1:
см. стр.1, № 15)
- (SATA3_2:
см. стр.1, № 17)
- (SATA3_3:
см. стр.1, № 9)
- (SATA3_4:
см. стр.1, № 8)
- (SATA3_5:
см. стр.1, № 6)



Эти шесть разъемов SATA3 предназначены для подключения кабелей SATA внутренних запоминающих устройств для передачи данных со скоростью до 6,0 Гб/с. Разъем SATA3_5 используется совместно с портом eSATA; разъем SATA3_4 используется совместно с гнездом mSATA/PCI Mini.

Колодки USB 2.0.

- (9-контактная,
USB_2_3)
(См. стр. 1, № 21)
- (9-контактная,
USB_4_5)
(см. стр. 1, № 20)

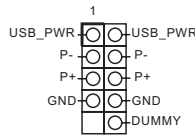

Кроме двух портов USB 2.0 на панели ввода-вывода на материнской плате также есть две колодки. Каждая колодка USB 2.0 может поддерживать два порта.

Колодки USB 3.0.

- (19-контактная,
USB3_5_6)
(См. стр. 1, № 7)

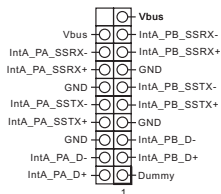

Кроме четырех портов USB 3.0 на панели ввода-вывода на материнской плате также есть одна колодка. Каждая колодка USB 3.0 может поддерживать два порта.

Аудиоколотка передней панели

(9-контактная, HD_AUDIO1)

(См. стр. 1, № 21)

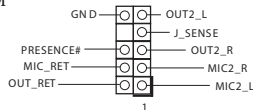

Эта колотка предназначена для подключения аудиоустройств к передней аудиопанели.



1. Аудиосистема высокого разрешения поддерживает функцию распознавания разъема, но для ее правильной работы необходимо, чтобы провод панели корпуса поддерживал передачу сигналов HDA. Инструкции по установке системы см. в этом руководстве и руководстве на корпус.
2. При использовании аудиопанели AC'97 подключите ее к аудиоколотке передней панели, как указано далее:
 - A. Подключите Mic_IN (MIC) к MIC2_L.
 - B. Подключите Audio_R (RIN) к OUT2_R, Audio_L (LIN) к OUT2_L.
 - C. Подключите провод заземления (GND) к контакту заземления (GND).
 - D. Контакты MIC_RET и OUT_RET используются только для аудиопанели высокого разрешения. При использовании аудиопанели AC'97 их подключать не нужно.
 - E. Чтобы активировать передний микрофон, перейдите на вкладку FrontMic панели управления Realtek и отрегулируйте параметр Recording Volume (Громкость записи).

Колодка динамика корпуса

(4-контактная, SPEAKER1)
(См. стр. 1, № 13)

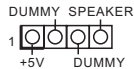

Предназначена для подключения динамика корпуса.

Разъемы для вентиляторов корпуса и блока питания

(4-контактный, CHA_FAN1)

(См. стр. 1, № 4)

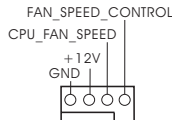

Предназначены для подключения кабелей разъемов вентиляторов и подключения черного провода к заземлению.

Разъемы вентиляторов ЦП

(4-контактный, CPU_FAN1)

(См. стр. 1, № 1)

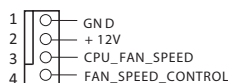

Эта материнская плата снабжена 4-контактным разъемом для маломощного вентилятора ЦП. Если вы собираетесь подключить 3-контактный вентилятор процессора, подключайте его к контактам 1-3.

Разъем питания ATX
(24-контактный,
ATXPWR1)
(См. стр. 1, № 5)

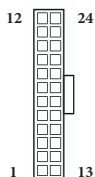

Эта материнская
плата снабжена
24-контактным
разъемом питания ATX.
Чтобы использовать
20-контактный
разъем питания ATX,
подключите его вдоль
контакта 1 и контакта
13.

Разъем питания ATX 12 В
(8-контактный,
ATX12V1)
(См. стр. 1, № 2)

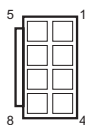

Эта материнская
плата снабжена
8-контактным разъемом
питания ATX 12 В.
Чтобы использовать
4-контактный
разъем питания ATX,
подключите его вдоль
контакта 1 и контакта 5.

Колодка для датчика
вскрытия корпуса
(2-контактная, С11)
(См. стр. 1, № 11)



Эта материнская плата
поддерживает технологию
определения вскрытия
корпуса по снятию верхней
части корпуса. Для этой
технологии необходим корпус
с функцией определения
вскрытия.

Колодка TPM
(17-контактная, TPMS1)
(См. стр. 1, № 10)

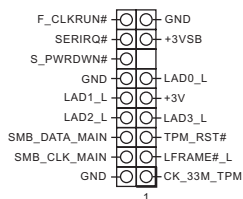

Этот разъем обеспечивает
поддержку системы
Trusted Platform Module
(TPM), которая способна
обеспечить надежное
хранение ключей, цифровых
сертификатов, паролей и
данных. Система TPM также
повышает уровень сетевой
безопасности, защищает
цифровые идентификаторы
и обеспечивает целостность
платформы.

1 Introdução

Obrigado por ter comprado a placa principal ASRock Z87E-ITX, uma placa principal fiável produzida sob os rigorosos critérios de controlo de qualidade da ASRock. Esta placa principal oferece um excelente desempenho com um design robusto em conformidade com o compromisso da ASRock em fabricar produtos de qualidade e resistentes.



Dado que as especificações da placa principal e o software do BIOS poderão ser actualizados, o conteúdo desta documentação estará sujeito a alterações sem aviso prévio. Caso ocorram modificações a este manual, a versão actualizada estará disponível no Web site da ASRock sem aviso prévio. Se necessitar de assistência técnica relacionada com esta placa principal, visite o nosso Web site para obter informações específicas acerca do modelo que está a utilizar. Também poderá encontrar a lista de placas VGA e CPU mais recentes suportadas no Web site da ASRock. Web site da ASRock <http://www.asrock.com>.

1.1 Conteúdo da embalagem

- Placa principal ASRock Z87E-ITX (Formato Mini-ITX)
- Guia de instalação rápida do ASRock Z87E-ITX
- CD de suporte ASRock Z87E-ITX
- 4 x Cabos de dados Serial ATA (SATA) (Opcional)
- 1 x Painel de E/S
- 1 x Antena ASRock WiFi 2,4GHz
- 1 x Conversor DVI para D-Sub

1.2 Especificações

- Plataforma**
- Formato Mini-ITX
 - Design de condensadores banhados a ouro de alta qualidade (Condensadores de polímeros condutores de alta qualidade 100% fabricados no Japão)

- CPU**
- Suporta processadores Intel® Core™ i7 / i5 / i3 / Xeon® / Pentium® / Celeron® de 4ª geração em socket LGA1150
 - Design Digi Power
 - Design com 6 fases de alimentação
 - DrMOS
 - Suporta a tecnologia Intel® Turbo Boost 2.0
 - Suporta CPU desbloqueado da série K da Intel®

- Chipset**
- Intel® Z87

- Memória**
- Tecnologia de memória DDR3 de dois canais
 - 2 x ranhuras DIMM DDR3
 - Suporta memória DDR3 2933+(OC)/2800(OC)/2400(OC)/2133(OC)/1866(OC)/1600/1333/1066, não ECC, sem memória intermédia
 - Capacidade máxima da memória do sistema: 16GB (consultar AVISO)
 - Suporta Extreme Memory Profile (XMP)1.3/1.2 da Intel®

- Ranhuras de expansão**
- 1 x ranhura PCI Express 3.0 x16
 - 1 x ranhura half mini-PCI Express: Para módulo WiFi + BT
 - 1 x ranhura mSATA/full mini-PCI Express

- Gráficos**
- Os gráficos incorporados Intel® HD e as saídas VGA apenas podem ser suportados com processadores com GPU integrada.
 - Suporta gráficos incorporados Intel® HD: Intel® Quick Sync Video com AVC, MVC (S3D) e MPEG-2 Full HW Encode1, Intel® InTru™ 3D, Tecnologia Intel® Clear Video HD, Intel® Insider™, Gráficos Intel® HD 4400/4600
 - Pixel Shader 5.0, DirectX 11.1
 - Memória partilhada máxima de 1792MB

- Três opções de saída VGA: DVI-I, HDMI e DisplayPort
- Suporta configuração com três monitores
- Suporta tecnologia HDMI 1.4a com resolução máxima de até 4K × 2K (4096x2304) a 24Hz
- Suporta DVI-I com resolução máxima de até 1920x1200 a 60Hz
- Suporta DisplayPort com resolução máxima de até 3840x2160 a 60Hz
- Suporta Auto sincronização labial, Deep Color (12bpc), xvYCC e HBR (High Bit Rate Audio) com HDMI (É necessário um monitor compatível com HDMI)
- Suporta a função HDCP com portas DVI-I, HDMI e DisplayPort
- Suporta reprodução Blu-ray (BD) / HD-DVD Full HD a 1080p com portas DVI-I, HDMI e DisplayPort

Áudio

- Áudio HD de 7.1 canais com protecção de conteúdo (Codec de áudio Realtek ALC1150)
- Suporte áudio Blu-ray superior
- TI® NE5532 (suporta amplificador de auscultadores premium até 600 Ohms)
- Suporta a tecnologia DTS Connect

LAN

- LAN Gigabit a 10/100/1000 Mb/s
- Giga PHY Intel® I217V
- Suporta tecnologia Intel® Remote Wake
- Suporta Wake-On-LAN
- Suporta IEEE 802.3az
- Suporta PXE

LAN sem fios

- Suporta IEEE 802.11a/b/g/n/ac
- Suporta banda dupla (2,4/5 GHz)
- Suporta ligação sem fios de alta velocidade até 867Mbps
- 2 antenas para suportar tecnologia de diversidade 2 (Transmissão) x 2 (Recepção)
- Suporta Bluetooth 4.0 / 3.0 + Classe II de alta velocidade

E/S do painel traseiro

- 1 x Porta PS/2 para rato/teclado
- 1 x porta DVI-I
- 1 x porta HDMI
- 1 x DisplayPort
- 1 x Porta de saída SPDIF óptica
- 1 x Conector eSATA
- 2 x portas USB 2.0
- 4 x portas USB 3.0
- 1 x Porta LAN RJ-45 com LED (LED ACT/LIGAÇÃO e LED DE VELOCIDADE)
- 1 x Interruptor para limpar o CMOS
- Ficha de áudio HD: Altifalante traseiro / Central / Graves / Entrada de linha / Altifalante frontal / Microfone

Armazenamento

- 6 x conectores SATA3 a 6,0 Gb/s, suporte para RAID (RAID 0, RAID 1, RAID 5, RAID 10, Tecnologia Intel Rapid Storage Technology 12 e Tecnologia Intel Smart Response), NCQ, AHCI e “Hot Plug” (o conector SATA3_5 é partilhado com a porta eSATA; o conector SATA3_4 é partilhado com a ranhura mSATA/mini-PCI Express)
- 1 x conector eSATA, com suporte para as funções NCQ, AHCI e “Hot Plug”
- 1 x conector mSATA a 6,0 Gb/s (conector para unidade de estado sólida), com suporte para as funções NCQ, AHCI e módulos Full-size mini-PCI Express

Conector

- 1 x Terminal de intrusão no chassis
- 1 x Terminal TPM
- 1 x Conector da ventoinha da CPU (4 pinos)
- 1 x Conector da ventoinha do chassis (4 pinos)
- 1 x conector de alimentação de 24 pinos ATX
- 1 x conector de alimentação de 12V com 8 pinos (Conector de alimentação de alta densidade)
- 1 x conector de áudio do painel frontal
- 2 x terminais USB 2.0 (suporte para 4 portas USB 2.0)
- 1 x terminal USB 3.0 (suporte para 2 portas USB 3.0)

Funcionalidades da BIOS

- BIOS UEFI oficial da AMI com 64Mb com suporte de interface multilíngue
- Eventos de reactivação compatíveis com ACPI 1.1
- Suporta SMBIOS 2.3.1
- Multi-ajuste de tensão de CPU, DRAM, PCH 1,05V, PCH 1,5V

- CD de suporte**
- Controladores, Utilitários, Software antivírus (versão de avaliação), CyberLink MediaEspresso 6.5 - Versão de avaliação, Navegador e Barra de Ferramentas Google Chrome, Start8, MeshCentral, Splashtop Streamer

Monitor de hardware

- Sensor de temperatura de CPU/Chassis
- Taquímetro de CPU/Chassis
- Ventoinha de CPU/Chassis silenciosa (Permite o ajuste automático da velocidade da ventoinha do chassis através da temperatura da CPU)
- Controlo de velocidade da ventoinha de CPU/Chassis
- Monitorização da tensão: +12V, +5V, +3,3V, CPU Vcore

Sistema Operativo

- Compatível com Microsoft® Windows® 8 / 8 64-bits / 7 / 7 64-bits

Certificações

- FCC, CE, WHQL
- Preparada para ErP/EuP (é necessária uma fonte de alimentação preparada para ErP/EuP)

* Para obter informações detalhadas acerca do produto, visite o nosso Web site: <http://www.asrock.com>



Tenha em atenção que o overclocking inclui um determinado grau de risco, incluindo o ajuste das definições na BIOS, a aplicação de tecnologia Untied Overclocking ou a utilização de ferramentas de overclocking de terceiros. O overclocking poderá afectar a estabilidade do sistema, ou mesmo causar danos aos componentes e dispositivos do seu sistema. Overclocking deverá ser efectuado por sua conta e risco. Não nos responsabilizamos por possíveis danos causados pelo overclocking.



Devido às limitações, o tamanho real da memória de 4GB reservada para utilização em sistemas operativos Windows® 32-bits poderá ser inferior. Os sistemas operativos Windows® 64-bits não possuem essas limitações. Pode utilizar o ASRock XFast RAM para dar uso à memória que o Windows® não utiliza.

1.3 Configuração dos jumpers

A imagem abaixo ilustra como os jumpers são configurados. Quando a tampa do jumper é colocada nos pinos, o jumper é "Curto". Se não for colocada uma tampa de jumper nos pinos, o jumper é "Aberto".

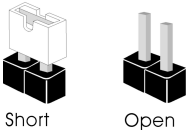

Short

Open

Jumper para limpar o CMOS
(CLRCMOS1)
(consultar p.1, N.º 14)



Jumper de 2 pinos

Curto: Limpar CMOS
Aberto: Predefinição

CLRCMOS1 permite-lhe limpar os dados no CMOS. Os dados no CMOS incluem informações de configuração do sistema, tal como palavra-passe do sistema, data, hora e parâmetros de configuração do sistema. Para limpar e repor os parâmetros do sistema para a configuração predefinida, desligue o computador e retire o cabo de alimentação, utilizando de seguida a tampa do jumper nos pinos de CLRCMOS1 durante 3 segundos. Não se esqueça de retirar a tampa do jumper depois de limpar o CMOS. Se precisar de limpar o CMOS logo após ter terminado uma actualização da BIOS, deverá primeiro iniciar o sistema e voltar a encerrá-lo antes de efectuar a acção de limpeza do CMOS.



1. O Interruptor para limpar o CMOS tem a mesma função do Jumper para limpar o CMOS.
2. Se limpar o CMOS, poderá ser detectada a abertura da caixa. Ajuste a opção do BIOS "Limpar estado" para limpar o registo anterior de estado de intrusão no chassis.

1.4 Terminais e conectores integrados



Os terminais e conectores integrados **NÃO** são jumpers. **NÃO** coloque tampas de jumpers sobre estes terminais e conectores. Colocar tampas de jumpers sobre os terminais e conectores irá causar danos permanentes à placa principal.

Terminal do painel de sistema
(PAINEL1 de 9 pinos)
(consultar p.1, N.º 12)

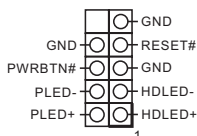

Ligue o botão de alimentação, o botão de reposição e o indicador do estado do sistema no chassis a este terminal de acordo com a descrição abaixo. Tenha em atenção os pinos positivos e negativos antes de ligar os cabos.



PWRBTN (Botão de alimentação):

Ligue ao botão de alimentação no painel frontal do chassis. Pode configurar a forma para desligar o seu sistema através do botão de alimentação.

RESET (Botão de reposição):

Ligue ao botão de reposição no painel frontal do chassis. Prima o botão de reposição para reiniciar o computador caso este bloqueie e não seja possível reiniciar normalmente.

PLED (LED de alimentação do sistema):

Ligue ao indicador do estado da alimentação no painel frontal do chassis. O LED ficará aceso quando o sistema estiver em funcionamento. O LED ficará intermitente quando o sistema estiver nos estados de suspensão S1/S3. O LED ficará desligado quando o sistema estiver no estado de suspensão S4 ou desligado (S5).

HDLED (LED de actividade do disco rígido):

Ligue ao LED de actividade do disco rígido no painel frontal do chassis. O LED ficará aceso quando o disco rígido estiver a ler ou a escrever dados.

O design do painel frontal poderá variar dependendo do chassis. Um módulo de painel frontal consiste principalmente em um botão de alimentação, um botão de reposição, um LED de alimentação, um LED de actividade do disco rígido, um altifalante, etc.

Ao ligar o seu módulo de painel frontal do chassis a este conector, certifique-se de que os fios e os pinos têm uma correspondência exacta.

Conectores ATA3 de série

(SATA3_0:

consultar p.1, N.º 16)

(SATA3_1:

consultar p.1, N.º 15)

(SATA3_2:

consultar p.1, N.º 17)

(SATA3_3:

consultar p.1, N.º 9)

(SATA3_4:

consultar p.1, N.º 8)

(SATA3_5:

consultar p.1, N.º 6)

SATA3_5



SATA3_4



SATA3_3



SATA3_2



SATA3_1



SATA3_0



Estes seis conectores

SATA3 suportam

cabos de dados SATA

para dispositivos de

armazenamento interno

com uma velocidade de

transferência de dados de

até 6,0 Gb/s. O conector

SATA3_5 é partilhado

com a porta eSATA; o

conector SATA3_4 é

partilhado com a ranhura

mSATA/mini-PCIe.

Terminais USB 2.0

(USB_2_3 de 9 pinos)

(consultar p.1, N.º 21)

(USB_4_5 de 9 pinos)

(consultar p.1, N.º 20)

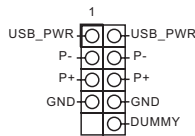

Para além das duas portas

USB 2.0 no painel de E/

S, existem dois terminais

nesta placa principal.

Cada terminal USB 2.0

é capaz de suportar duas

portas.

Terminais USB 3.0

(USB3_5_6 de 19 pinos)

(consultar p.1, N.º 7)

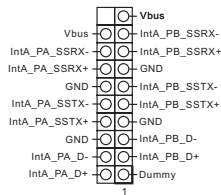

Para além das quatro

portas USB 3.0 no painel

de E/S, existe um terminal

nesta placa principal.

Cada terminal USB 3.0 é

capaz de suportar duas

portas.

Terminal de áudio do
painel frontal
(HD_AUDIO1 de 9 pinos)
(consultar p.1, N.º 21)

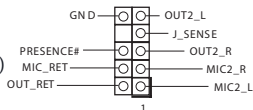

Este terminal destina-se
à ligação de dispositivos
áudio ao painel de áudio
frontal.



1. O Áudio de alta definição suporta Detecção de ficha, mas o cabo de painel no chassis deverá suportar HDA para funcionar correctamente. Siga as instruções no nosso manual e no manual do chassis para instalar o seu sistema.
2. Se utilizar um painel de áudio AC'97, instale-o no terminal de áudio do painel frontal de acordo com os passos abaixo:
 - A. Ligue Mic_IN (MIC) a MIC2_L.
 - B. Ligue Audio_R (RIN) a OUT2_R e Audio_L (LIN) a OUT2_L.
 - C. Ligue Terra (GND) a Terra (GND).
 - D. MIC_RET e OUT_RET destinam-se apenas ao painel de áudio HD. Não precisa de os ligar para o painel de áudio AC'97.
 - E. Para activar o microfone frontal, aceda ao separador "Microfone Frontal" no painel de controlo Realtek e ajuste o "Volume de gravação".

Terminal do altifalante do
chassis
(SPEAKER1 de 4 pinos)
(consultar p.1, N.º 13)



Ligue o altifalante do
chassis a este terminal.

Conectores da ventoinha
do chassis e alimentação
(CHA_FAN1 de 4 pinos)
(consultar p.1, N.º 4)

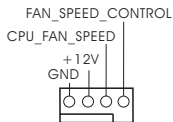

Ligue os cabos da
ventoinha aos conectores
da ventoinha colocando
o cabo preto no pino de
ligação à terra.

Conectores da ventoinha
da CPU
(CPU_FAN1 de 4 pinos)
(consultar p.1, N.º 1)

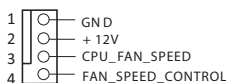

Esta placa principal inclui
um conector de ventoinha
de CPU (Ventoinha
silenciosa) de 4 pinos.
Se pretender ligar uma
ventoinha de CPU de 3
pinos, ligue-a ao Pino 1-3.

Conector de alimentação ATX

(ATXPWR1 de 24 pinos)
(consultar p.1, N.º 5)

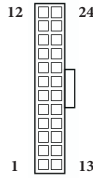

Esta placa principal inclui um conector de alimentação ATX de 24 pinos. Para utilizar uma fonte de alimentação ATX de 20 pinos, introduza-a no Pino 1 o Pino 13.

Conector de alimentação de 12V ATX

(ATX12V1 de 8 pinos)
(consultar p.1, N.º 2)

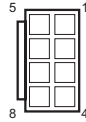

Esta placa principal inclui um conector de alimentação de 12V ATX de 8 pinos. Para utilizar uma fonte de alimentação ATX de 4 pinos, introduza-a no Pino 1 o Pino 5.

Terminal de intrusão do chassis

(CII de 2 pinos)
(consultar p.1, N.º 11)



Esta placa principal suporta a função de detecção de ABERTURA da CAIXA que detecta se a tampa do chassis foi removida. Esta função requer um chassis com design de detecção de intrusão.

Terminal TPM

(TPMS1 de 17 pinos)
(consultar p.1, N.º 10)

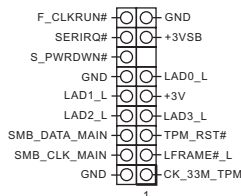

Este conector suporta um sistema com Módulo de Plataforma Confiável (TPM), que pode armazenar com segurança chaves, certificados digitais, palavras-passe e dados. Um sistema TPM também ajuda a melhorar a segurança de rede, a proteger identidades digitais e a garantir a integridade da plataforma.

1 Giriş

ASRock'ın zorlu kalite kontrol süreçlerinden geçmiş olan ASRock Z87E-ITX anakartını satın aldığınız için teşekkür ederiz. Sağlam tasarımı ile ASRock'ın kalite ve dayanıklılık taahhüdüne uygun şekilde mükemmel performans sağlar.



Anakart özellikleri ve BIOS yazılımı güncellenebileceğinden, bu dokümantasyonun içeriği herhangi bir bildirimde bulunulmaksızın değiştirilebilir. Bu kılavuz üzerinde herhangi bir değişiklik yapılması halinde, güncellenmiş sürüm, herhangi bir bildirim yapılmaksızın ASRock'ın web sitesinde yer alacaktır.. Bu anakart ile ilgili olarak teknik destek almak istiyorsanız, lütfen kullandığınız model hakkında özel bilgiler için web sitemizi ziyaret edin. En güncel VGA kartları ve CPU destek listelerini de ASRock'ın web sitesinden bulabilirsiniz. ASRock'ın web sitesi <http://www.asrock.com>.

1.1 Ambalaj İçeriği

- ASRock Z87E-ITX Anakartı (Mini-ITX Form Faktörü)
- ASRock Z87E-ITX Hızlı Kurulum Kılavuzu
- ASRock Z87E-ITX Destek CD'si
- 4 x Seri ATA (SATA) Veri Kablosu (İsteğe Bağlı)
- 1 x I/O Panel Kalkanı
- 1 x ASRock WiFi 2.4GHz Anten
- 1 x DVI-to-D-Sub Dönüştürücü

1.2 Özellikler

Platform

- Mini-ITX Form Faktörü
- Premium Gold Sığa tasarımı (%100 Japon-malı kaliteli İletken Polimer Sığalar)

CPU

- 4ncü Nesil Intel® Core™ i7 / i5 / i3 / Xeon® / Pentium® / Celeron®, LGA1150 Paketinde desteklemektedir
- Dijital Güç Tasarımı
- 6 Güç Safhası Tasarımı
- DrMOS
- Intel® Turbo Boost 2.0 Teknolojisini destekler
- Intel® K-Serisi kilitsiz CPU özelliğini destekler

Yonga kümesi

- Intel® Z87

Bellek

- Çift Kanallı DDR3 Bellek Teknolojisi
- 2 x DDR3 DIMM yuvaları
- DDR3 2933+(OC)/2800(OC)/2400(OC)/2133(OC)/1866(OC)/1600/1333/1066 ECC olmayan, ara belleğe alınmamış belleği destekler
- Maksimum sistem belleği kapasitesi: 16GB (bkz. DİKKAT ikazı)
- Intel® Üstün Bellek Profili (XMP)1.3/1.2 özelliğini destekler

Genişletme

Yuvası

- 1 x PCI Express 3.0 x16 yuva
- 1 x yarı mini-PCI Express yuvası: WiFi + BT modülü için
- 1 x mSATA/tam mini-PCI Express yuvası:

Grafikler

- Intel® HD Graphics Dahili Görselleri ile VGA çıktıları, yalnızca GPU entegre edilmiş işlemciler ile desteklenir.
- Intel® HD Graphics Dahili Görsellerini destekler : AVC, MVC (S3D) ve MPEG-2 Full HW Encode1, Intel® InTru™ 3D, Intel® Net Video HD Teknolojisi, Intel® Insider™, Intel® HD Graphics 4400/4600 ile Intel® Quick Sync Video
- Pixel Shader 5.0, DirectX 11.1
- Maksimum paylaşılan bellek 1792MB

- Üç VGA Çıkışı seçeneği: DVI-I, HDMI ve DisplayPort
- Üçlü Monitör Desteği
- 4K x 2K (4096x2304) @ 24Hz'ye kadar çözünürlükte HDMI teknolojisini destekler
- 1920x1200 @ 60Hz'ye kadar DVI-I işlevini destekler
- 3840x2160 @ 60Hz'ye kadar DisplayPort işlevini destekler
- HDMI ile Otomatik Dudak Senkronizasyonu (12bpc-, xvYCC ve HBR (Yüksek Bit Hızında Ses) özelliklerini destekler (Uyumlu bir HDMI monitörü kullanılmalıdır)
- DVI-I, HDMI ve DisplayPort bağlantı noktaları ile HDCP işlevini destekler
- DVI-I, HDMI ve DisplayPort bağlantı noktalarıyla, Full HD 1080p Blu-ray (BD) / HD-DVD kayıttan yürütme özelliklerini destekler

Ses

- İçerik Koruma Özelliği ile 7.1 CH HD Ses (Realtek ALC1150 Ses Codec Bileşeni)
- Üstün Blu-ray ses desteği
- TT® NE5532 (600 Ohm'a kadar Premium Kulaklık Yükselticisi desteği)
- DTS Connect işlevini destekler

LAN

- Gigabit LAN 10/100/1000 Mb/s
- Giga PHY Intel® I217V
- Intel® Uzaktan Uyandırma Teknolojisi
- LAN Açılışını Destekler
- Enerji Verimliliğine Sahip Ethernet 802.3az işlevini destekler
- PXE özelliğini destekler

Kablosuz LAN

- IEEE 802.11a/b/g/n/ac işlevini destekler
- Çift Bant özelliğini destekler (2,4/5 GHz)
- 867Mbps'ye kadar yüksek hızlı kablosuz bağlantıları destekler
- 2 (Verici) x 2 (Alıcı) olmak üzere eşzaman teknolojisini destekleyecek 2 anten
- Bluetooth 4.0 / 3.0 + II. sınıf yüksek hızı destekler

Arka Panel I/O

- 1 x PS/2 Fare/Klavye Bağlantı Noktası
- 1 x DVI-I Bağlantı Noktası
- 1 x HDMI Bağlantı Noktası
- 1 x DisplayPort
- 1 x Optik SPDIF Çıkışı Bağlantı Noktası
- 1 x eSATA Bağlayıcısı
- 2 x USB 2.0 Bağlantı noktası
- 4 x USB 3.0 Bağlantı noktası
- LED'e sahip 1 x RJ-45 LAN Bağlantı Noktası (ACT/LINK LED ve SPEED LED)
- 1 x CMOS'u Temizle Anahtarı
- HD Ses Jakı: Arka Hoparlör / Merkezi / Bas / Hat Girişi / Ön Hoparlör / Mikrofon

Depolama

- 6 x SATA3 6,0 Gb/s bağlayıcıları, RAID (RAID 0, RAID 1, RAID 5, RAID 10, Intel Hızlı Depolama Teknolojisi 12 ve Intel Akıllı Yanıt Teknolojisi), NCQ, AHCI ve "Hot Plug" işlevlerini destekler (SATA3_5 bağlayıcısı eSATA bağlantı noktası, SATA3_4 bağlayıcısı da mSATA/mini-PCI Express yuvası ile paylaşılır)
- 1 x eSATA bağlayıcısı, NCQ, AHCI ve "Hot Plug" işlevlerini destekler
- 1 x mSATA 6,0 Gb/s bağlayıcısı (Kattı Hal Sürücüsü bağlayıcısı), NCQ, AHCI işlevlerini ve Tam boyutlu mini-PCI Express modüllerini destekler

Bağlayıcı

- 1 x Kasa Yetkisiz Erişim bağlantısı
- 1 x TPM bağlantısı
- 1 x CPU Fan bağlayıcısı (4-pin)
- 1 x Kasa Fanı bağlayıcısı (4-pin)
- 1 x 24 pin ATX güç bağlayıcısı
- 1 x 8 pin 12V güç bağlayıcısı (Yüksek Yoğunluklu Güç Bağlayıcısı)
- 1 x Ön panel ses bağlayıcısı
- 2 x USB 2.0 bağlantısı (4 USB 2.0 bağlantı noktasını destekler)
- 1 x USB 3.0 bağlantısı (2 USB 3.0 bağlantı noktasını destekler)

BIOS Özelliği

- Çok dilli GUI Desteği ile 64Mb AMI UEFI Legal BIOS
- ACPI 1.1 Uyumluluğu Uyandırma Olayları
- SMBIOS 2.3.1 Desteği
- CPU, DRAM, PCH 1,05V, PCH 1,5V Voltaj Çoklu Ayarı

Destek CD'si

- Sürücüler, Yardımcı Yazılımlar, AntiVirüs Yazılımı (Deneme Sürümü), CyberLink MediaEspresso 6.5 Deneme Sürümü, Google Chrome Tarayıcı ve Araç Çubuğu, Start8, MeshCentral, Splashtop Streamer, Intel® Extreme Tuning Utility (XTU)

Donanım Monitörü

- CPU/Kasa Sıcaklığı Tespiti
- CPU/Kasa Devirölçer
- CPU/Kasa Sessiz Fan (Kasa Fan Hızının CPU Sıcaklığına Göre Otomatik olarak Ayarlanmasını Sağlar)
- CPU/Kasa Fanı Çoklu Hız Kontrolü
- Voltaj Denetleme: +12V, +5V, +3,3V, CPU Vcore

OS

- Microsoft® Windows® 8 / 8 64-bit / 7 / 7 64-bit ile uyumlu

Belgeler

- FCC, CE, WHQL
- ErP/EuP için hazır (ErP/EuP için hazır güç beslemesi gereklidir)

* Detaylı ürün bilgisi için, lütfen web sitemizi ziyaret edin: <http://www.asrock.com>



Lütfen, BIOS ayarlarını düzenleme, Bağımsız Hız Aşırtma Teknolojinin uygulanması ya da üçüncü kişilerin hız aşırma araçlarının kullanılması da dahil olmak üzere tüm hız aşırma işlemlerinin belirli bir risk taşıdığını unutmayın. Hız aşırma, sisteminizin dayanıklılığını etkileyebilir, hatta sisteminizde yer alan bileşen ve aygıtlara zarar verebilir. Bunu riski ve masrafları size ait olmak üzere gerçekleştirilmelidir. Hız aşırmadan doğabilecek zararlar konusunda sorumlu olmayacağız.



Sınırlamalar nedeniyle, gerçek bellek boyutu Windows® 32-bit işletim sistemleri çerçevesinde sistem kullanımına ayrıldığı için 4GB'den az olabilir. Windows® 64-bit işletim sistemlerinde bu tür sınırlamalar yoktur. Windows® tarafından kullanılmayan bellekten faydalanmak için ASRock XFast RAM'i kullanabilirsiniz.

1.3 Bağlantı Teli Kurulumu

Çizim, bağlantı tellerinin kurulumunu göstermektedir. Tel kapağı, pimlerin üzerine yerleştirildiğinde, tel "Kısa" olur. Pimlerin üzerinde tel kapağı bulunmadığında, tel "Kısa" olur.

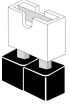

Short



Open

CMOS'u Temizle Bağlantı
Teli
*(CLRCMOS1)
(bkz. sf.1, No. 14)



2-pin Bağlantı Teli

Kısa: CMOS'u Temizle
Açık: Varsayılan

CLRCMOS1, CMOS verilerini temizlememizi sağlar. CMOS içindeki veriler, sistem parolası, tarih, saat ve sistem kurulum parametreleri gibi kurulum bilgilerini içermektedir. Sistem parametrelerini silmek ve varsayılan kurulum ayarlarına dönmek için, lütfen bilgisayarı kapatın ve güç kablosunu çekin, ardından, CLRCMOS1 üzerindeki pimleri 3 saniye boyunca kısaltmak için bir bağlantı teli kapağı kullanın. Lütfen CMOS'u temizledikten sonra bağlantı teli kapağını çıkarmayı unutmayın. BIOS'u güncelledikten hemen sonra CMOS'u temizlemeniz gerekirse, önce sistemi başlatın ve ardından CMOS temizleme işlemi öncesinde yeniden kapatın.



1. CMOS'u Temizle Anahtarı, CMOS'u Temizle bağlantı teli ile aynı işleve sahiptir.
2. CMOS'u temizlerseniz, kasa açık uyarısı alabilirsiniz. Önceki kasa yetkisiz erişim durumu kaydını silmek için lütfen BIOS durumunu "Durumu Temizle" olarak belirleyin.

1.4 Ekli Bağlantılar ve Bağlayıcılar



Ekli bağlantılar ve bağlayıcılar bağlantı teli değildir. Bağlantı teli kapaklarını bu bağlantı ve bağlayıcılar üzerine yerleştirmeyin. Bağlantı teli kapaklarının bağlantılar ile bağlayıcılar üzerine yerleştirilmesi, anakarta kalıcı hasar verebilir.

Sistem Paneli Bağlantısı
(9-pin PANEL1)
(bkz sf.1, No. 12)

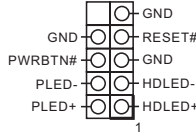

Güç anahtarını bağlayın, kasa üzerindeki anahtar ile sistem durumu belirtecini aşağıdaki pim düzenine göre sıfırlayın. Kabloları bağlarken pozitif ve negatif pimleri not edin.



PWRBTN (Güç Anahtarı):

Güç anahtarını kasa ön paneline bağlayın. Güç anahtarını kullanarak sistemin hangi yöne hareketle kapanacağını seçebilirsiniz.

RESET (Sıfırlama Anahtarı):

Sıfırlama anahtarını kasa ön paneline bağlayın. Bilgisayarın kilitlenmesi ve normal şekilde yeniden başlatılmaması halinde reset (sıfırla) düğmesine basın.

PLED (Sistem Gücü LED):

Güç durumu belirtecini kasa ön paneline bağlayın. Sistem çalışırken LED ışığı yanacaktır. Sistem S1/S3 uyku durumdayken LED ışığı yanıp söner. Sistem S4 uyku durumunda ya da kapalıyken (S5) LED ışık kapanır.

HDLED (Sabit Disk Aktivitesi LED):

Sabit Disk Aktivitesi LED'i kasanın ön paneline bağlayın. Sabit sürücü veri okur ya da yazarken LED ışığı yanar.

Ön panel tasarımı kasaya göre değişiklik gösterebilir. Bir ön panel modülü, temel olarak bir güç anahtarı, sıfırlama anahtarı, güç LED'i, sabit sürücü aktivitesi LED'i, hoparlör gibi birimlerden oluşur. Kasanızın ön panel modülünü bu bağlantıya takmadan önce, kablo düzenlemeleri ile pin düzenlemelerinin düzgün şekilde yapıldığından emin olun.

Seri ATA3 Bağlayıcıları

(SATA3_0:

bkz. sf.1, No. 16)

(SATA3_1:

bkz. sf.1, No. 15)

(SATA3_2:

bkz. sf.1, No. 17)

(SATA3_3:

bkz. sf.1, No. 9)

(SATA3_4:

bkz. sf.1, No. 8)

(SATA3_5:

bkz. sf.1, No. 6)

SATA3_5



SATA3_4



SATA3_3



SATA3_2



SATA3_1



SATA3_0



Bu altı SATA3 bağlayıcısı,

veri aktarım hızı 6,0 Gb/

sn'ye kadar olan dahili

depolama aygıtları için

tasarlanmış SATA veri

kablolarını destekler.

SATA3_5 bağlayıcısı

eSATA bağlantı noktası,

SATA3_4 bağlayıcısı da

mSATA/mini-PCIe yuvası

ile paylaşılır.

USB 2.0 Bağlantıları

(9-pin USB_2_3)

(bkz. sf.1, No. 21)

(9-pin USB_4_5)

(bkz. sf.1, No. 20)

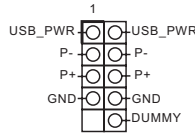

Bu anakart üzerinde, I/O

paneli üzerindeki iki USB

2.0 bağlantı noktasının

yanı sıra, iki adet bağlantı

bulunmaktadır. Her

USB 2.0 bağlantısı, iki

adet bağlantı noktasını

destekleyebilir.

USB 3.0 Bağlantıları

(19-pin USB3_5_6)

(bkz. sf.1, No. 7)

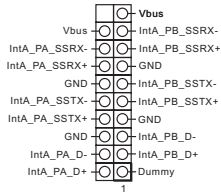

Bu anakart üzerinde,

I/O paneli üzerindeki

dört USB 3.0 bağlantı

noktasının yanı sıra,

bir adet bağlantı

bulunmaktadır. Her

USB 3.0 bağlantısı, iki

adet bağlantı noktasını

destekleyebilir.

Ön Panel Ses Bağlantısı
(9-pin HD_AUDIO1)
(bkz. sf.1, No. 21)

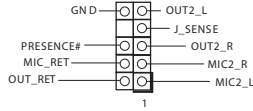

Bu bağlantı, ses aygıtlarının ön ses paneline bağlanması içindir.



- Yüksek Tanımlı Ses, Jak Algılama özelliğini destekler, ancak bu işlevin düzgün çalışabilmesi için kasa üzerindeki panel kablosunun HDA işlevini desteklemesi gerekmektedir. Sisteminizi kurarken, lütfen kılavuzumuzdaki talimatlar ile kasa kılavuzundaki talimatları izleyin.
- Bir AC'97 ses paneli kullanıyorsanız, lütfen bu paneli aşağıdaki adımları izleyerek ön panel ses bağlantısına takın:
 - Mic_IN (MIC)'i MIC2_L'ye bağlayın.
 - Audio_R (RIN)'i OUT2_R'ye ve Audio_L (LIN)'yi OUT2_L'ye bağlayın.
 - Topraklamayı (GND) Topraklamaya (GND) bağlayın.
 - MIC_RET ve OUT_RET, yalnızca HD ses paneli içindir. Bunları AC'97 ses panelinden bağlamanıza gerek yoktur.
 - Ön mikrofonu etkinleştirmek için Realtek Denetim panelinde yer alan "FrontMic (Ön Mikrofon)" Sekmesine tıklayın ve "Recording Volume (Kayıt Sesi Düzeyi)" değerini ayarlayın.

Kasa Hoparlör Bağlantısı
(4-pin SPEAKER1)
(bkz. sf.1, No. 13)

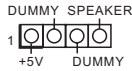

Lütfen kasa hoparlörünü bu bağlantıya takın.

Kasa ve Güç Fanı Bağlayıcıları
(4-pin CHA_FAN1)
(bkz. sf.1, No. 4)

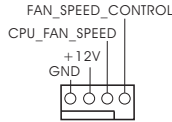

Lütfen fan kablolarını fan bağlayıcılarına takın ve siyah teli topraklama pinine bağlayın.

CPU Fan Bağlayıcıları
(4-pin CPU_FAN1)
(bkz. sf.1, No. 1)

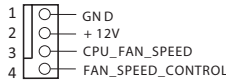

Bu anakart, 4-Pin CPU fan (Sessiz Fan) bağlayıcısı sağlamaktadır. 3-Pin CPU fan bağlamak istiyorsanız, lütfen Pin 1-3'ü kullanın.

ATX Güç Bağlayıcısı
(24-pin ATXPWR1)
(bkz. sf.1, No. 5)

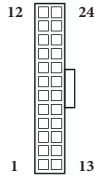

Bu anakart, 24-pin ATX güç bağlayıcısı sağlamaktadır. 20-pin ATX güç beslemesi kullanmak için, lütfen Pin 1 ve Pin13'e bağlayın.

ATX 12V Güç Bağlayıcısı
(8-pin ATX12V1)
(bkz. sf.1, No. 2)

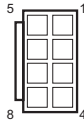

Bu anakart, 8-pin ATX 12V güç bağlayıcısı sağlamaktadır. 4-pin ATX güç beslemesi kullanmak için, lütfen Pin 1 ve Pin5'e bağlayın.

Kasa Yetkisiz Erişim
Bağlantısı
(2-pin C11)
(bkz. sf.1, No. 11)



Bu anakart kasa kapağının açılıp açılmadığını tespit eden bir KASA AÇIK özelliği bulunmaktadır. Bu özelliğin kullanılabilmesi için kasa yetkisiz erişim tasarımına sahip bir kasa kullanılmalıdır.

TPM Bağlantısı
(17-pin TPMS1)
(bkz. sf.1, No. 10)

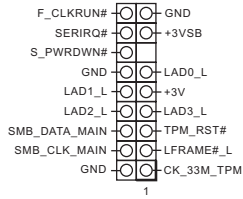

Bu bağlayıcı, anahtarlar, dijital sertifikalar, parolalar ve verileri güvenli bir şekilde saklama özelliği bulunan Güvenilir Platform Modülü (TPM) sistemini destekler. TPM sistemleri, aynı zamanda ağ güvenliğinin artırılması, dijital kimliklerin korunması ve platform bütünlüğünün sağlanmasına da yardımcıdır.

1 개요

ASRock Z87E-ITX 마더보드를 구입해 주셔서 감사합니다. 이 마더보드는 ASRock의 일관되고 엄격한 품질관리 하에 생산되어 신뢰성이 우수하며, 품질과 내구성에 대한 ASRock의 기준에 부합하는 우수한 성능과 견고한 설계를 제공합니다.



마더보드 규격과 BIOS 소프트웨어를 업데이트할 수도 있기 때문에, 이 문서의 내용은 예고 없이 변경될 수 있습니다. 이 설명서가 변경될 경우, 업데이트된 버전은 ASRock의 웹사이트에서 추가 통지 없이 제공됩니다. 이 마더보드와 관련하여 기술적 지원이 필요한 경우, 당사의 웹사이트를 방문하여 사용 중인 모델에 대한 구체적인 정보를 구하십시오. ASRock의 웹사이트에서는 최신 VGA 카드와 CPU 지원 목록도 찾을 수 있습니다. ASRock 웹사이트 <http://www.asrock.com>.

1.1 포장 내용물

- ASRock Z87E-ITX 마더보드 (Mini-ITX 폼팩터)
- ASRock Z87E-ITX 간편 설치 안내서
- ASRock Z87E-ITX 지원 CD
- 시리얼 ATA (SATA) 데이터 케이블 4 개 (선택 품목)
- I/O 패널 실드 1 개
- ASRock WiFi 2.4GHz 안테나 1 개
- DVI - D-Sub 컨버터 1 개

1.2 규격

플랫폼

- Mini-ITX 폼 팩터
- 프리미엄 골드 콘텐서 구조 (100% 일본산 고품질 전도성 폴리머 콘텐서)

CPU

- LGA1150 패키지로 제공되는 4 세대 Intel® Core™ i7 / i5 / i3 / Xeon® / Pentium® / Celeron® 지원 Digi 전원 구조
- 6 개 전원 위상 구조
- DrMOS
- Intel® Turbo Boost 2.0 기술 지원
- Intel® K- 시리즈 잠금 해제 CPU 지원

칩세트

- Intel® Z87

메모리

- 듀얼 채널 DDR3 메모리 기술
- DDR3 DIMM 슬롯 2 개
- DDR3 2933+(OC)/2800(OC)/2400(OC)/2133(OC)/1866(OC)/1600/1333/1066 비-ECC, 비버퍼링 메모리 지원
- 시스템 메모리 최대 용량 : 16GB (주의 참조)
- Intel® Extreme Memory Profile (XMP)1.3/1.2 지원

확장 슬롯

- PCI Express 3.0 x16 슬롯 1 개
- 하프 mini-PCI Express 슬롯 1 개 : WiFi + BT 모듈용
- mSATA/ 풀 mini-PCI Express 슬롯 1 개

그래픽

- Intel® HD 그래픽스 빌트 - 인 비주얼과 VGA 출력은 GPU 통합 프로세서로만 지원할 수 있습니다.
- Intel® HD 그래픽스 빌트 - 인 비주얼 지원 : AVC, MVC (S3D) 및 MPEG-2 풀 HW Encode1 지원 Intel® Quick Sync Video, Intel® InTru™ 3D, Intel® 클리어 비디오 HD 기술, Intel® Insider™, Intel® HD 그래픽스 4400/4600
- Pixel Shader 5.0, DirectX 11.1
- 최대 공유 메모리 1792MB

- VGA 출력 옵션 세 개 : DVI-I, HDMI 및 DisplayPort
- 삼중 모니터 지원
- HDMI 기술 지원 (최대 해상도 4K × 2K (4096x2304) @ 24Hz)
- DVI-I 지원 (최대 해상도 1920x1200 @ 60Hz)
- DisplayPort 지원 (최대 해상도 3840x2160 @ 60Hz)
- Auto Lip Sync, Deep Color (12bpc), xvYCC 및 HBR (High Bit Rate Audio)(HDMI 포함) 지원 (HDMI 호환 모니터 필요)
- DVI-I, HDMI 및 DisplayPort 포트를 이용한 HDCP 기능 지원
- DVI-I, HDMI 및 DisplayPort 포트를 이용한 Full HD 1080p Blu-ray (BD) / HD-DVD 재생 지원

오디오

- 콘텐츠 보호를 이용한 7.1 CH HD 오디오 지원 (Realtek ALC1150 오디오 코덱)
- 프리미엄 Blu-ray 오디오 지원
- TI* NE5532 (최대 600 옴의 프리미엄 헤드셋 증폭기 지원)
- DTS 연결 지원

LAN

- Gigabit LAN 10/100/1000 Mb/s
- Giga PHY Intel I217V
- Intel 리모트 웨이크 기술 지원
- Wake-On-LAN 지원
- 절전형 이더넷 802.3az 지원
- PXE 지원

무선 LAN

- IEEE 802.11a/b/g/n/ac 지원
- 듀얼 밴드 (2.4/5 GHz) 지원
- 최대 867Mbps 의 고속 무선 연결 지원
- 2 (송신) x 2 (수신) 다이버시티 기술 지원용 안테나 2 개
- Bluetooth 4.0 / 3.0 + 고속 클래스 II 지원

후면 패널 I/O

- PS 1 개 / 마우스 / 키보드 포트 2 개
- DVI-I 포트 1 개
- HDMI 포트 1 개
- DisplayPort 1 개
- 광학 SPDIF 출력 포트 1 개
- eSATA 커넥터 1 개
- USB 2 포트 2 개
- USB 4 포트 3.0 개
- LED 장착 RJ-45 LAN 포트 1 개 (ACT/LINK LED 및 SPEED LED)
- Clear CMOS 스위치 1 개
- HD 오디오 잭 : 후면 스피커 / 중앙 / 베이스 / 라인 입력 / 전면 스피커 / 마이크

저장 장치

- SATA3 6.0 Gb/s 커넥터 6 개가 RAID (RAID 0, RAID 1, RAID 5, RAID 10, Intel 빠른 스토리지 기술 12 및 Intel 스마트 응답 기술), NCQ, AHCI 및 “ 핫 플러그 ” 를 지원 (SATA3_5 커넥터는 eSATA 포트와 공유되며, SATA3_4 커넥터는 mSATA/mini-PCI Express 슬롯과 공유됨)
- eSATA 커넥터 1 개, NCQ, AHCI 및 “ 핫 플러그 ” 기능 지원
- mSATA 6.0 Gb/s 커넥터 1 개 (SSD 커넥터), NCQ, AHCI 기능 및 전체 크기 mini-PCI Express 모듈 지원

커넥터

- 새시 침입 헤더 1 개
- TPM 헤더 1 개
- CPU 팬 커넥터 1 개 (4 핀)
- 새시 팬 커넥터 1 개 (4 핀)
- 24 핀 ATX 전원 커넥터 1 개
- 8 핀 12V 전원 커넥터 1 개 (고밀도 전원 커넥터)
- 전면 패널 오디오 커넥터 1 개
- USB 2.0 헤더 2 개 (USB 2.0 포트 4 개 지원)
- USB 3.0 헤더 1 개 (USB 3.0 포트 2 개 지원)

BIOS 기능	<ul style="list-style-type: none"> • 다국어 GUI 지원을 제공하는 64Mb AMI UEFI 적합형 BIOS • ACPI 1.1 준수 웨이크 업 이벤트 • SMBIOS 2.3.1 지원 • CPU, DRAM, PCH 1.05V, PCH 1.5V 전압 다중 조정
지원 CD	<ul style="list-style-type: none"> • 드라이버, 유틸리티, 백신 소프트웨어 (시험판), CyberLink MediaEspresso 6.5 시험판, Google Chrome 브라우저 및 톨바, Start8, MeshCentral, Splashtop Streamer, Intel® Extreme Tuning Utility (IXTU)
하드웨어 모니터	<ul style="list-style-type: none"> • CPU/ 새시 온도 감지 • CPU/ 새시 타코미터 • CPU/ 새시 저소음 팬 (CPU 온도에 의한 새시 팬 속도 자동 조정) • CPU/ 새시 팬 다중 속도 조절 • 전압 모니터링 : +12V, +5V, +3.3V, CPU Vcore
OS	<ul style="list-style-type: none"> • Microsoft® Windows® 8 / 8 64 비트 / 7 / 7 64 비트 호환
인증	<ul style="list-style-type: none"> • FCC, CE, WHQL • ErP/EuP 사용 가능 (ErP/EuP 사용 가능 전원공급장치 필요)

* 자세한 제품 정보에 대해서는 당사 웹사이트를 참조하십시오 : <http://www.asrock.com>



BIOS 설정을 조정하거나 **Untied Overclocking Technology** 를 적용하거나 타업체의 오버클로킹 도구를 사용하는 것을 포함하는 오버클로킹에는 어느 정도의 위험이 따른다는 것을 유념하십시오. 오버클로킹은 시스템 안정성에 영향을 주거나 심지어 시스템의 구성 요소와 장치에 손상을 입힐 수도 있습니다. 오버클로킹은 사용자 스스로 위험과 비용을 감수하고 해야 합니다. 당사는 오버클로킹에 의해 발생할 수 있는 손상에 대해서 책임이 없습니다.



제한 때문에 실제 메모리 크기는 Windows® 32 비트 운영체제 하의 시스템 사용을 위한 예비 메모리용 4GB 보다 더 적을 수 있습니다. Windows® 64 비트 운영체제에는 그러한 제한이 없습니다. ASRock XFast RAM 을 사용하여 Windows® 가 사용할 수 없는 메모리를 이용할 수 있습니다.

1.3 점퍼 설정

그림은 점퍼를 어떻게 설정하는지 보여줍니다. 점퍼 캡을 핀에 끼우면 점퍼가 “단락”됩니다. 점퍼 캡을 핀에 끼우지 않으면 점퍼가 “단선”됩니다.

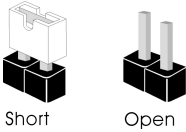

Clear CMOS 점퍼
(CLR CMOS1)
(1 페이지, 14 번 항목 참조)



2 핀 점퍼

단락 : Clear CMOS
단선 : 기본값

CLR CMOS1 을 사용하여 CMOS 에 저장된 데이터를 지울 수 있습니다. CMOS 에 저장된 데이터에는 시스템 암호, 날짜, 시간 및 시스템 설정 파라미터와 같은 시스템 설정 정보가 포함됩니다. 시스템 파라미터를 지우고 기본 설정으로 초기화하려면 컴퓨터를 끄고 전원 코드를 뽑은 다음 점퍼 캡을 사용하여 CLR CMOS1 의 핀을 3 초 동안 단락시키십시오. CMOS 를 지운 후 반드시 점퍼 캡을 제거하십시오. BIOS 업데이트를 완료한 직후 CMOS 를 지워야 할 경우, 우선 시스템을 부팅한 후 바이오스 업데이트를 종료한 다음 CMOS 지우기 작업을 해야 합니다.



1. Clear CMOS 스위치는 Clear CMOS 점퍼와 동일한 기능을 갖고 있습니다.
2. CMOS 를 지울 경우 케이스 열림이 감지될 수도 있습니다. BIOS 옵션 “Clear Status(상태 지우기)”를 조절하여 이전의 새시 침입 상태에 대한 기록을 지우십시오.

1.4 온보드 헤더 및 커넥터



온보드 헤더와 커넥터는 점퍼가 아닙니다. 점퍼 캡을 온보드 헤더와 커넥터에 씌우지 마십시오. 점퍼 캡을 온보드 헤더와 커넥터에 씌우면 마더보드가 영구적으로 손상됩니다.

시스템 패널 헤더
(9 핀 PANEL1)
(1 페이지, 12 번 항목 참조)

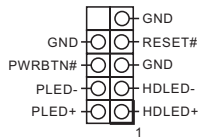

새시의 전원 스위치, 리셋 스위치, 시스템 상태 표시등을 아래의 핀 할당에 따라 이 헤더에 연결합니다. 케이블을 연결하기 전에 양극 핀과 음극 핀을 기록합니다.



PWRBTN(전원 스위치):

새시 전면 패널의 전원 스위치에 연결합니다. 전원 스위치를 이용해 시스템을 끄는 방법을 구성할 수 있습니다.

RESET(리셋 스위치):

새시 전면 패널의 리셋 스위치에 연결합니다. 컴퓨터가 정지하고 정상적 재시작을 수행하지 못할 경우 리셋 스위치를 눌러 컴퓨터를 재시작합니다.

PLED(시스템 전원 LED):

새시 전면 패널의 전원 상태 표시등에 연결합니다. 시스템이 작동하고 있을 때는 LED가 켜져 있습니다. 시스템이 S1/S3 대기 상태에 있을 때는 LED가 계속 깜박입니다. 시스템이 S4 대기 상태 또는 전원 꺼짐(S5) 상태에 있을 때는 LED가 꺼져 있습니다.

HDLED(하드 드라이브 동작 LED):

새시 전면 패널의 하드 드라이브 동작 LED에 연결합니다. 하드 드라이브가 데이터를 읽거나 쓰고 있을 때 LED가 켜져 있습니다.

전면 패널 디자인은 새시별로 다를 수 있습니다. 전면 패널 모듈은 주로 전원 스위치, 리셋 스위치, 전원 LED, 하드 드라이브 동작 LED, 스피커 등으로 구성되어 있습니다. 새시 전면 패널 모듈을 이 헤더에 연결할 때 와이어 할당과 핀 할당이 정확히 일치하는지 확인합니다.

시리얼 ATA3 커넥터
 (SATA3_0:
 1 페이지, 16 번 항목 참조)
 (SATA3_1:
 1 페이지, 15 번 항목 참조)
 (SATA3_2:
 1 페이지, 17 번 항목 참조)
 (SATA3_3:
 1 페이지, 9 번 항목 참조)
 (SATA3_4:
 1 페이지, 8 번 항목 참조)
 (SATA3_5:
 1 페이지, 6 번 항목 참조)



이들 6 개의 SATA3 커넥터는 최대 6.0 Gb/s 데이터 전송 속도를 제공하는 내부 저장 장치용 SATA 데이터 케이블을 지원합니다. SATA3_5 커넥터는 eSATA 포트와 공유되며 SATA3_4 커넥터는 mSATA/mini-PCIe 슬롯과 공유됩니다.

USB 2.0 헤더
 (9 핀 USB_2_3)
 (1 페이지, 21 번 항목 참조)
 (9 핀 USB_4_5)
 (1 페이지, 20 번 항목 참조)

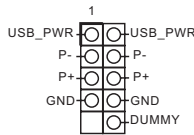

I/O 패널에 USB 2.0 포트 두 개가 탑재되어 있을 뿐 아니라 마더보드에 헤더 두 개가 탑재되어 있습니다. 각 USB 2.0 헤더는 포트 두 개를 지원할 수 있습니다.

USB 3.0 헤더
 (19 핀 USB3_5_6)
 (1 페이지, 7 번 항목 참조)

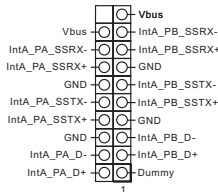

I/O 패널에 USB 3.0 포트 네 개가 탑재되어 있을 뿐 아니라 마더보드에 헤더 한 개가 탑재되어 있습니다. 각 USB 3.0 헤더는 포트 두 개를 지원할 수 있습니다.

고
사
하
기

전면 패널 오디오 헤더
(9 핀 HD_AUDIO1)
(1 페이지, 21 번 항목 참조)

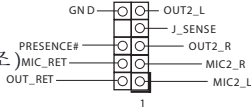

이 헤더는 오디오 장치를 전면 오디오 패널에 연결하는 데 사용됩니다.



- 고품질 오디오는 객 감지를 지원하지만 올바르게 작동하려면 새시의 패널 와이어가 HDA를 지원해야 합니다. 설명서 및 새시 설명서에 나와 있는 지침을 따라 시스템을 설치하십시오.
- AC '97 오디오 패널을 사용할 경우 아래와 같은 절차를 따라 전면 패널 오디오 헤더에 설치하십시오:
 - Mic_IN (MIC)을 MIC2_L에 연결합니다.
 - Audio_R (RIN)을 OUT2_R에 연결하고 Audio_L (LIN)을 OUT2_L에 연결합니다.
 - 접지 (GND)를 접지 (GND)에 연결합니다.
 - MIC_RET 및 OUT_RET는 HD 오디오 패널에만 사용됩니다. AC '97 오디오 패널용으로 연결할 필요가 없습니다.
 - 전면 마이크를 활성화하려면 Realtek 제어판에서 "FrontMic" 탭으로 가서 "Recording Volume(녹음 볼륨)"을 조정합니다.

새시 스피커 헤더
(4 핀 SPEAKER1)
(1 페이지, 13 번 항목 참조)

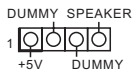

새시 스피커를 이 헤더에 연결하십시오.

새시 및 전원 팬 커넥터
(4 핀 CHA_FAN1)
(1 페이지, 4 번 항목 참조)

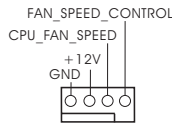

팬 케이블을 팬 커넥터에 연결하고 검은색 와이어를 접지핀에 연결하십시오.

CPU 팬 커넥터
(4 핀 CPU_FAN1)
(1 페이지, 1 번 항목 참조)

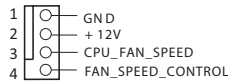

이 마더보드에는 4 핀 CPU 팬 (저소음 팬) 커넥터가 탑재되어 있습니다. 3 핀 CPU 팬을 연결하려는 경우 핀 1-3에 연결하십시오.

ATX 전원 커넥터
(24 핀 ATXPWR1)
(1 페이지, 5 번 항목 참조)

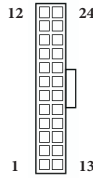

이 마더보드에는 24 핀 ATX 전원 커넥터가 탑재되어 있습니다. 20 핀 ATX 전원공급장치를 사용하려면 핀 1 과 핀 13 을 따라 연결하십시오.

ATX 12V 전원 커넥터
(8 핀 ATX12V1)
(1 페이지, 2 번 항목 참조)

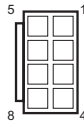

이 마더보드에는 8 핀 ATX 12V 전원 커넥터가 탑재되어 있습니다. 4 핀 ATX 전원공급장치를 사용하려면 핀 1 과 핀 5 을 따라 연결하십시오.

새시 침입 헤더
(2 핀 CII)
(1 페이지, 11 번 항목 참조)



이 마더보드는 새시 커버가 제거될 경우 이를 감지하는 케이스 열림 감지 기능을 지원합니다. 이 기능을 사용하려면 새시 침입 감지 설계가 적용된 새시를 사용해야 합니다.

TPM 헤더
(17 핀 TPMS1)
(1 페이지, 10 번 항목 참조)

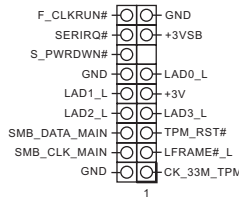

이 커넥터는 키, 디지털 인증서, 암호 및 데이터를 안전하게 보관할 수 있는 TPM(Trusted Platform Module) 시스템을 지원합니다. TPM 시스템은 네트워크 보안을 강화하고, 디지털 신원을 보호하며 플랫폼 무결성을 유지합니다.

고급

1 はじめに

アスロックの一貫した厳格な品質管理の下で製造された信頼性の高いマザーボードであるアスロック Z87E-ITX マザーボードをお買い上げいただきありがとうございます。アスロックの品質と耐久性の取り組みに準拠した堅牢な設計を持つ、優れたパフォーマンスを提供します。



マザーボードの仕様と BIOS ソフトウェアは更新されることがあるため、このマニュアルの内容は予告なしに変更することがあります。このマニュアルの内容に変更があった場合には、更新されたバージョンは、予告なくアスロックのウェブサイトから入手できるようになります。このマザーボードに関する技術的なサポートが必要な場合には、ご使用のモデルについての詳細情報を、当社のウェブサイトで参照ください。アスロックのウェブサイトでは、最新の VGA カードおよび CPU サポート一覧もご覧になれます。アスロックウェブサイト <http://www.asrock.com>。

1.1 パッケージの内容

- アスロック Z87E-ITX マザーボード (ミニ ITX フォームファクター)
- アスロック Z87E-ITX クイックインストールガイド
- アスロック Z87E-ITX サポート CD
- 4 x シリアル ATA (SATA) データケーブル (オプション)
- 1 x I/O パネルシールド
- 1 x アスロック WiFi 2.4GHz アンテナ
- 1 x DVI-to-D-Sub コンバーター

1.2 仕様

- プラットフォーム
- ミニ ITX フォームファクター
 - プレミアムゴールドコンデンサー設計 (100% 日本製の高品質導電性高分子コンデンサー)

- CPU
- LGA1150 パッケージでは、第 4 世代の Intel® Core™ i7 / i5 / i3 / Xeon® / Pentium® / Celeron® をサポート
 - デジタル電源設計
 - 6 電源フェーズ設計
 - Dr. MOS
 - Intel® ターボブースト 2.0 テクノロジーをサポート
 - Intel® K シリーズ、アンロック CPU をサポート

- チップセット
- Intel® Z87

- メモリ
- デュアルチャンネル DDR3 メモリテクノロジー
 - 2 x DDR3 DIMM スロット
 - DDR3 2933+(OC)/2800(OC)/2400(OC)/2133(OC)/1866(OC)/1600/1333/1066 ECC なし、アンバッファードメモリをサポート
 - システムメモリの最大容量：16GB
(注意を参照)
 - Intel® エクストリームメモリプロファイル (XMP) 1.3/1.2 をサポート

- 拡張スロット
- 1 x PCI Express 3.0 x16 スロット
 - 1 x ハーフミニ PCI Express スロット：WiFi + BT モジュール用
 - 1 x mSATA/ フル ミニ PCI Express スロット

- グラフィックス
- Intel® HD グラフィックス内蔵ビジュアルおよび VGA 出力は、GPU に統合されたプロセッサのみでサポートされます。
 - Intel® HD グラフィックス内蔵ビジュアルをサポート：AVC、MVC (S3D)、MPEG-2 フル HW エンコード 1 の Intel® Quick Sync Video、Intel® InTru™ 3D、Intel® クリアビデオ HD テクノロジー、Intel® インサイダー™、Intel® HD グラフィックス 4400/4600
 - ピクセルシェーダー 5.0、DirectX 11.1
 - 最大共有メモリ 1792MB

- 3つのVGA出力オプション：DVI-I、HDMI、ディスプレイポート
- 3台のモニターをサポート
- HDMIテクノロジーをサポート。最大解像度4K × 2K (4096x2304) @24Hz
- DVI-Iをサポート。最大解像度1920x1200 @60Hz
- ディ스플레이ポートをサポート。最大解像度3840x2160 @60Hz
- HDMI (HDMI準拠のモニターが必要) では、オートリッピンク、ディープカラー (12bpc)、xvYCC、HBR (高ビットレートオーディオ) をサポート
- DVI-I、HDMI、ディスプレイポートで、HDCP機能をサポート
- DVI-I、HDMI、ディスプレイポートで、フルHD 1080pブルーレイ (BD) / HD-DVD再生をサポート

音声

- 7.1 CH HD オーディオ、コンテンツプロテクション付き (Realtek ALC1150 オーディオコーデック)
- プレミアムブルーレイオーディオサポート
- TI® NE5532 (最大600Ωのプレミアムヘッドセットアンプをサポート)
- DTS接続をサポート

LAN

- ギガビットLAN 10/100/1000 Mb/秒
- ギガPHY Intel® I217V
- Intel® リモートウェイクテクノロジーをサポート
- ウェイクオンランをサポート
- エネルギー効率のよいイーサネット 802.3az をサポート
- PXE をサポート

ワイヤレス LAN

- IEEE 802.11a/b/g/n/ac をサポート
- デュアルバンド (2.4/5 GHz) をサポート
- 最高867Mbpsの高速ワイヤレス接続をサポート
- 2 (送信) × 2 (受信) ダイバーシティテクノロジーをサポートする2本のアンテナ
- ブルートゥース 4.0/3.0 + ハイスピードクラス II をサポート

- リアパネル I/O**
- 1 x PS/2 マウス / キーボードポート
 - 1 x DVI-I ポート
 - 1 x HDMI ポート
 - 1 x ディスプレイポート
 - 1 x 光 SPDIF 出力ポート
 - 1 x eSATA コネクタ
 - 2 x USB 2.0 ポート
 - 4 x USB 3.0 ポート
 - LED 付き 1 x RJ-45 LAN ポート (ACT/LINK LED と SPEED LED)
 - 1 x CMOS クリアスイッチ
 - HD オーディオジャック: リアスピーカー / センター / バス / ラインイン / フロントスピーカー / マイク

- ストレージ**
- 6 x SATA3 6.0 Gb/ 秒コネクタ、RAID サポート (RAID 0、RAID 1、RAID 5、RAID 10、Intel ラピッドストレージテクノロジー 12、Intel スマートレスポンステクノロジー)、NCQ、AHCI、「ホットプラグ」(eSATA ポートと共有の SATA3_5 コネクタ、mSATA/ ミニ-PCI Express スロットと共有の SATA3_4 コネクタ)
 - 1 x eSATA コネクタ、NCQ、AHCI、「ホットプラグ」機能をサポート
 - 1 x mSATA 6.0 Gb/ 秒コネクタ (SSD コネクタ)、NCQ、AHCI 機能、フルサイズミニ PCI Express モジュールをサポート

- コネクタ**
- 1 x シャーシインテリゲーションヘッダー
 - 1 x TPM ヘッダー
 - 1 x CPU ファンコネクタ (4 ピン)
 - 1 x シャーシファンコネクタ (4 ピン)
 - 1 x 24 ピン ATX 電源コネクタ
 - 1 x 8 ピン 12V 電源コネクタ (高密度電源コネクタ)
 - 1 x 前面パネルオーディオコネクタ
 - 2 x USB 2.0 ヘッダー (4 つの USB 2.0 ポートをサポート)
 - 1 x USB 3.0 ヘッダー (2 つの USB 3.0 ポートをサポート)

BIOS 機能	<ul style="list-style-type: none">• 多言語 GUI サポート付きの 64Mb AMI UEFI Legal BIOS• ACPI 1.1 準拠のウェイクアップイベント• SMBIOS 2.3.1 をサポート• CPU、DRAM、PCH 1.05V、PCH 1.5V 複数電圧設定
サポート CD	<ul style="list-style-type: none">• ドライバー、ユーティリティ、アンチウイルスソフトウェア（トライアル版）、CyberLink MediaEspresso 6.5 トライアル、Google Chrome ブラウザー、ツールバー、Start8、MeshCentral、Splashtop Streamer、Intel® エクストリームチューニングユーティリティー（IXTU）
ハードウェアモ ニター	<ul style="list-style-type: none">• CPU/ シャーシ温度センサー• CPU / シャーシタコメーター• CPU/ シャーシ静音ファン（CPU 温度によるシャーシファン速度の自動調整可能）• CPU/ シャーシファンマルチ速度制御• 電圧監視： +12V、+5V、+3.3V、CPU Vcore
OS	<ul style="list-style-type: none">• Microsoft® Windows® 8 / 8 64 ビット / 7 / 7 64 ビット準拠
認証	<ul style="list-style-type: none">• FCC、CE、WHQL• ErP/EuP Ready（ErP/EuP ready 電源が必要です）

* 商品詳細については、当社ウェブサイトをご覧ください。 <http://www.asrock.com>



BIOS 設定の調整、アンタイドオーバークロックテクノロジーの適用、サードパーティのオーバークロックツールの使用などを含む、オーバークロックには、一定のリスクを伴いますのでご注意ください。オーバークロックするとシステムが不安定になったり、システムのコンポーネントやデバイスが破損することがあります。ご自分の責任で行ってください。弊社では、オーバークロックによる破損の責任は負いかねますのでご了承ください。



Windows® 32 ビットオペレーティングシステムでの、システム使用に割り当てられた実際のメモリサイズは制限のため、4GB 未満のことがあります。Windows® 64 ビットのオペレーティングシステムでは、そのような制限はありません。Windows® では使えないメモリを使用するために、アスロック XFast RAM を使用することができます。

1.3 ジャンパー設定

このイラストは、ジャンパーの設定方法を示しています。ジャンパーキャップがピンに被さっていると、ジャンパーは「ショート」です。ジャンパーキャップがピンに被さっていない場合には、ジャンパーは「オープン」です。

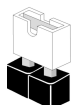

Short



Open

CMOS クリアジャンパー
(CLR CMOS1)
(p.1、No. 14 参照)



ショート： CMOS クリア
オープン： デフォルト

CLR CMOS1 は、CMOS のデータをクリアすることができます。 CMOS のデータには、システムパスワード、日付、時間、システム設定パラメーターなどのシステム設定情報が含まれます。消去して、デフォルト設定にシステムパラメーターをリセットするには、コンピューターの電源を切り、電源コードを抜き、ジャンパーキャップを使用して、CLR CMOS1 のピンに 3 秒間ショートします。 CMOS をクリアした後は、ジャンパーキャップを取り外すのを忘れないようにしてください。 BIOS をアップデート後、CMOS をクリアする必要がある場合は、最初にシステムを起動し、それから CMOS クリアアクションを行う前にシャットダウンしてください。



1. CMOS クリアスイッチは、CMOS クリアジャンパーと同じ機能です。
2. CMOS をクリアすると、ケースの開閉が検知されることがあります。以前のシャシインテリジェンスステータス記録を消去するには、BIOS オプションから「Clear Status (ステータスの消去)」で調整してください。

1.4 オンボードのヘッダーとコネクタ



オンボードヘッダーとコネクタはジャンパーではありません。これらヘッダーとコネクタにはジャンパーキャップを被せないでください。ヘッダーおよびコネクタにジャンパーキャップを被せると、マザーボードに永久損傷が起こることがあります。

システムパネルヘッダー
(9ピンパネル1)
(p.1, No. 12 参照)

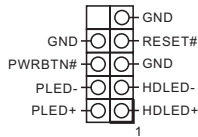

電源スイッチを接続し、スイッチをリセットし、下記のピン割り当てに従って、シャーシのシステムステータス表示ランプをこのヘッダーにセットします。ケーブルを接続するときには、ピンの+と-に気をつけてください。



PWRBTN (電源スイッチ) :

シャーシ前面パネルの電源スイッチに接続してください。電源スイッチを使用して、システムをオフにする方法を設定できます。

RESET (リセットスイッチ) :

シャーシ前面パネルのリセットスイッチに接続してください。コンピューターがフリーズしたり、通常の再起動を実行できない場合には、リセットスイッチを押して、コンピューターを再起動します。

PLED (システム電源 LED) :

シャーシ前面パネルの電源ステータス表示ランプに接続してください。システム稼働中は、LED が点灯します。システムが S1/S3 スリープ状態の場合には、LED は点滅を続けます。システムが S4 スリープ状態または電源オフ (S5) のときには、LED はオフです。

HDLED (ハードドライブアクティビティ LED) :

シャーシ前面パネルのハードドライブアクティビティ LED に接続してください。ハードドライブのデータを読み取りまたは書き込み中に、LED はオンになります。

前面パネルデザインは、シャーシによって異なることがあります。前面パネルモジュールは、主に電源スイッチ、リセットスイッチ、電源 LED、ハードドライブアクティビティ LED、スピーカーなどから構成されます。シャーシの前面パネルモジュールとこのヘッダーを接続する場合には、配線の割り当てと、ピンの割り当てが正しく合致していることを確かめてください。

シリアル ATA3 コネクタ

- (SATA3_0:
 p.1, No. 16 参照)
 (SATA3_1:
 p.1, No. 15 参照)
 (SATA3_2:
 p.1, No. 17 参照)
 (SATA3_3:
 p.1, No. 9 参照)
 (SATA3_4:
 p.1, No. 8 参照)
 (SATA3_5:
 p.1, No. 6 参照)



これら 6 つの SATA3 コネクタは、最高 6.0 Gb/秒のデータ転送速度で内部ストレージデバイス用の SATA データケーブルをサポートします。SATA3_5 コネクタは eSATA ポートと共有です。SATA3_4 コネクタは、mSATA/ ミニ PCIe スロットと共有です。

USB 2.0 ヘッダー

- (9 ピン USB_2_3)
 (p.1, No. 21 参照)
 (9 ピン USB_4_5)
 (p.1, No. 20 参照)

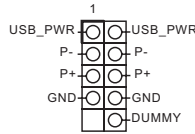

I/O パネルの 2 つの USB 2.0 ポートに加えて、このマザーボードには 2 つのヘッダーがあります。各 USB 2.0 ヘッダーは、2 つのポートをサポートできます。

USB 3.0 ヘッダー

- (19 ピン USB3_5_6)
 (p.1, No. 7 参照)

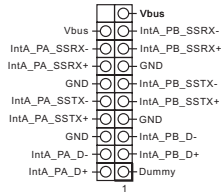

I/O パネルの 4 つの USB 3.0 ポートに加えて、このマザーボードには 1 つのヘッダーがあります。各 USB 3.0 ヘッダーは、2 つのポートをサポートできます。

フロントパネルオーディオヘッダー

(9ピン HD_AUDIO1)
(p.1, No. 21 参照)

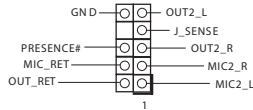

このヘッダーは、フロントオーディオパネルにオーディオデバイスを接続するためのものです。



- ハイディフィニションオーディオはジャックセンシングをサポートしていますが、正しく機能するためには、シャーシのパネルワイヤーがHDAをサポートしている必要があります。お使いのシステムを取り付けるには、当社のマニュアルおよびシャーシのマニュアルの指示に従ってください。
- AC'97オーディオパネルを使用する場合には、次のステップで、前面パネルオーディオヘッダーに取り付けてください。
 - Mic_IN (MIC) を MIC2_L に接続。
 - Audio_R (RIN) を OUT2_R に、Audio_L (LIN) を OUT2_L に接続。
 - アース (GND) をアース (GND) に接続。
 - MIC_RET と OUT_RET は、HD オーディオパネル専用です。AC'97 オーディオパネルではこれらを接続する必要はありません。
 - フロントマイクを有効にするには、Realtek コントロールパネルの「FrontMic」タブで、「録音音量」を調整してください。

シャーシスピーカーヘッダー

(4ピン SPEAKER1)
(p.1, No. 13 参照)

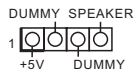

シャーシスピーカーはこのヘッダーに接続してください。

シャーシと電源ファンコネクタ

(4ピン CHA_FAN1)
(p.1, No. 4 参照)

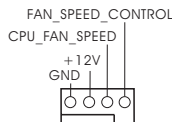

ファンケーブルはファンコネクタに接続し、黒線とアースピンを合わせてください。

CPU ファンコネクタ

(4ピン CPU_FAN1)
(p.1, No. 1 参照)

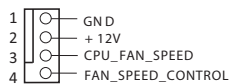

このマザーボードは4ピンCPUファン（静音ファン）コネクタを提供します。3ピンのCPUファンを接続する場合には、ピン1-3に接続してください。

ATX 電源コネクタ
(24 ピン ATXPWR1)
(p.1、No. 5 参照)

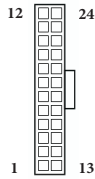

このマザーボードは 24 ピン ATX 電源コネクタを提供します。20 ピンの ATX 電源を使用するには、ピン 1 と 13 番に合わせて接続してください。

ATX12V 電源コネクタ
(8 ピン ATX12V1)
(p.1、No. 2 参照)

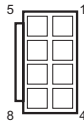

このマザーボードは 8 ピン ATX12V 電源コネクタを提供します。4 ピンの ATX 電源を使用するには、ピン 1 と 5 番に合わせて接続してください。

シャーシントラージョン
ンヘッダー
(2 ピン CII)
(p.1、No. 11 参照)



このマザーボードはシャーシカバーが開けられたことを検知する、ケース開閉検知機能をサポートします。この機能には、シャーシントラージョン検知設計されたシャーシが必要です。

TPM ヘッダー
(17 ピン TPMS1)
(p.1、No. 10 参照)

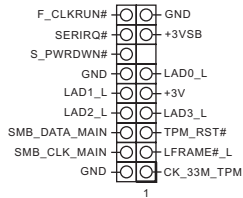

このコネクタはトラステッドプラットフォームモジュール(TPM)システムをサポートし、鍵、デジタル証明書、パスワード、データを安全に保管することができます。TPM システムはまた、ネットワークセキュリティを高め、デジタル証明書を保護し、プラットフォームの完全性を保証します。

1 简介

感谢您购买 ASRock Z87E-ITX 主板，这是按照 ASRock 一贯严格质量控制标准生产的性能可靠的主板。它提供符合 ASRock 质量和耐久性承诺的精良设计和卓越性能。



由于主板规格和 BIOS 软件可能已更新，因此，本文档的内容可能会随时更改，恕不另行通知。如果本手册有任何修改，则更新的版本将发布在 ASRock 网站上，我们不会另外进行通知。如果您需要与此主板相关的技术支持，请访问我们的网站以具体了解所用型号的信息。您也可以在 ASRock 网站上找到最新 VGA 卡和 CPU 支持列表。ASRock 网站 <http://www.asrock.com>。

1.1 包装清单

- ASRock Z87E-ITX 主板 (Mini-ITX 规格尺寸)
- ASRock Z87E-ITX 快速安装指南
- ASRock Z87E-ITX 支持光盘
- 4 x 串行 ATA (SATA) 数据线 (选购)
- 1 x I/O 面板
- 1 x ASRock WiFi 2.4GHz 天线
- 1 x DVI 转 D-Sub 转换器

1.2 规格

平台

- Mini-ITX 规格尺寸
- 优质亮金电容器设计 (100% 日本造高品质导电性高分子电容器)

CPU

- 支持 LGA1150 封装第 4 代 Intel® Core™ i7 / i5 / i3 / Xeon® / Pentium® / Celeron®
- Digi Power (帝捷) 设计
- 6 电源相设计
- DrMOS
- 支持 Intel® Turbo Boost 2.0 技术
- 支持 Intel® K 系列不锁频 CPU

芯片集

- Intel® Z87

内存

- 双通道 DDR3 内存技术
- 2 x DDR3 DIMM 槽
- 支持 DDR3 2933+(OC)/2800(OC)/2400(OC)/2133(OC)/1866(OC)/1600/1333/1066 非 ECC、非缓冲内存
- 支持系统内存容量：16GB (见“注意”)
- 支持 Intel® Extreme Memory Profile (XMP)1.3/1.2

扩充槽

- 1 x PCI Express 3.0 x16 槽
- 1 x 半尺寸 mini-PCI Express 槽：对于 WiFi + BT 模块
- 1 x mSATA/ 完全 mini-PCI Express 槽

图形

- 只有 GPU 集成的处理器才支持 Intel® HD Graphics 内置视效和 VGA 输出。
- 支持 Intel® HD Graphics 内置视效：Intel® 快速同步视频，采用 AVC、MVC (S3D) 和 MPEG-2 Full HW Encode、Intel® InTru™ 3D、Intel® Clear Video HD 技术、Intel® Insider™、Intel® HD Graphics 4400/4600
- Pixel Shader 5.0、DirectX 11.1
- 最大共享内存 1792MB

- 三个 VGA 输出选项：DVI-I、HDMI 和 DisplayPort
- 支持三台监视器
- 支持 HDMI 技术，24Hz 时最大分辨率达 4K × 2K (4096x2304)
- 支持 DVI-I，60Hz 时最大分辨率达 1920x1200
- 支持 DisplayPort，60Hz 时最大分辨率达 3840x2160
- 通过 HDMI (需要符合规格的 HDMI 监视器) 支持 Auto Lip Sync、Deep Color (12bpc), xvYCC 和 HBR (高位速率音频)
- 通过 DVI-I、HDMI 和 DisplayPort 端口支持 HDCP 功能
- 通过 DVI-I、HDMI 和 DisplayPort 端口支持 Full HD 1080p Blu-ray (BD) / HD-DVD 播放

音频

- 具有内容保护功能的 7.1 CH 高清音频 (Realtek ALC1150 音频编解码器)
- 优质 Blu-ray 音频支持
- TI* NE5532 (支持最高 600 Ohms 高品质耳机放大器)
- 支持 DTS 连接

LAN

- Gigabit LAN 10/100/1000 Mb/s
- Giga PHY Intel® I217V
- 支持 Intel® Remote Wake (远程唤醒) 技术
- 支持 Wake-On-LAN (网上唤醒)
- 支持高效以太网 802.3az
- 支持 PXE

无线 LAN

- 支持 IEEE 802.11a/b/g/n/ac
- 支持双频段 (2.4/5 GHz)
- 支持最高 867Mbps 的高速无线连接
- 2 个天线可支持 2 (发射) x 2 (接收) 分集技术
- 支持 Bluetooth 4.0 / 3.0 + 高速 Class II

后面板 I/O

- 1 x PS/2 鼠标 / 键盘端口
- 1 x DVI-I 端口
- 1 x HDMI 端口
- 1 x DisplayPort
- 1 x 光学 SPDIF 输出端口
- 1 x eSATA 接口
- 2 x USB 2.0 端口
- 4 x USB 3.0 端口
- 1 x RJ-45 LAN 端口，带 LED (ACT/LINK LED 和 SPEED LED)
- 1 x 清除 CMOS 开关
- 高清音频插孔：后扬声器 / 中央 / 低音 / 线路输入 / 前扬声器 / 麦克风

存储

- 6 x SATA3 6.0 Gb/s 接口，支持 RAID (RAID 0、RAID 1、RAID 5、RAID 10、Intel Rapid Storage Technology 12 和 Intel Smart Response Technology)、NCQ、AHCI 和“热插拔”(SATA3_5 接口与 eSATA 端口共享；SATA3_4 接口与 mSATA/mini-PCI Express 槽共享)
- 1 x eSATA 接口，支持 NCQ、AHCI 和“热插拔”功能
- 1 x mSATA 6.0 Gb/s 接口 (固态驱动器接口)，支持 NCQ、AHCI 功能和完全尺寸 mini-PCI Express 模块

接口

- 1 x 机箱侵入接脚
- 1 x TPM 接脚
- 1 x CPU 风扇接口 (4 针)
- 1 x 机箱风扇接口 (4 针)
- 1 x 24 针 ATX 电源接口
- 1 x 8 针 12V 电源接口 (高密度电源接口)
- 1 x 前面板音频接口
- 2 x USB 2.0 接脚 (支持 4 个 USB 2.0 端口)
- 1 x USB 3.0 接脚 (支持 2 个 USB 3.0 端口)

BIOS 功能特点

- 64Mb AMI UEFI Legal BIOS，具有多语言 GUI 支持
- ACPI 1.1 兼容唤醒事件
- SMBIOS 2.3.1 支持
- CPU、DRAM、PCH 1.05V、PCH 1.5V 电压多次调整 (Voltage Multi-adjustment)

支持光盘

- 驱动程序、实用程序、防病毒软件 (试用版)、CyberLink MediaEspresso 6.5 试用版、Google Chrome 浏览器和工具栏、Start8、MeshCentral、Splashtop Streamer、Intel® Extreme Tuning Utility (IXTU)

硬件监控

- CPU/ 机箱温度感测
- CPU/ 机箱转速计
- CPU/ 机箱静音风扇 (可以按照 CPU 温度自动调整机箱风扇速度)
- CPU/ 机箱风扇多种速度控制
- 电压监控: +12V、+5V、+3.3V、CPU Vcore

操作系统

- Microsoft® Windows® 8 / 8 64-bit / 7 / 7 64-bit 兼容

认证

- FCC、CE、WHQL
- ErP/EuP 支持 (需要支持 ErP/EuP 的电源)

* 有关详细产品信息, 请访问我们的网站: <http://www.asrock.com>



须认识到超频会有一定风险，包括调整 BIOS 设置，应用“自由超频技术”，或使用第三方超频工具。超频可能会影响到系统的稳定性，甚至对系统的组件和设备造成损坏。执行这项工作您应自担风险和自己承担费用。我们对由于超频而造成的损坏概不负责。



由于限制原因，实际内存容量可能会小于 4GB，以保留给 Windows® 32-bit 操作系统下的系统使用。Windows® 64-bit 操作系统没有此类限制。您可以使用 ASRock XFast RAM 来利用 Windows® 不能使用的内存。

1.3 跳线设置

此图显示如何设置跳线。将跳线帽装到这些针脚上时，跳线“短接”。如果这些针脚上没有装跳线帽，跳线“开路”。

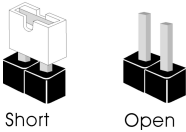

清除 CMOS 跳线
(CLRCMOS1)
(见第 1 页, 第 14 个)



2 针跳线

短接: 清除 CMOS
开路: 默认

CLRCMOS1 允许您清除 CMOS 中的数据。CMOS 中的数据包括系统设置信息，如系统密码、日期、时间和系统设置参数。要清除和重置系统参数为默认设置，请关闭计算机，拔下电源线插头，然后使用跳线帽短接 CLRCMOS1 上的针脚 3 秒。请记住在清除 CMOS 后取下跳线帽。如果您需要在刚完成 BIOS 更新后清除 CMOS，则必须先启动系统，并在关闭后再执行清除 CMOS 操作。



1. 清除 CMOS 开关具有与清除 CMOS 跳线相同的功能。
2. 如果您清除 CMOS，机箱打开会被检测到。请将 BIOS 选项“Clear Status”（清除状态）调整为清除前一个机箱侵入状态的记录。

1.4 板载接脚和接口



板载接脚和接口不是跳线。不要将跳线帽装到这些接脚和接口上。将跳线帽装到这些接脚和接口上将会对主板造成永久性损坏。

系统面板接脚

(9 针 PANEL1)

见第 1 页, 第 12 个)

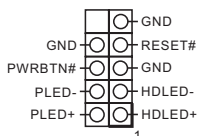

按照下面的针脚分配, 将机箱上的电源开关、重置开关和系统状态指示灯连接到此接脚。在连接线缆前请记下正负针脚。



PWRBTN (电源开关):

连接到机箱前面板上的电源开关。您可以配置使用电源开关关闭系统的方式。

RESET (重置开关):

连接到机箱前面板上的重置开关。如果计算机死机, 无法执行正常重新启动, 按重置开关重新启动计算机。

PLED (系统电源 LED):

连接到机箱前面板上的状态指示灯。系统操作操作时, 此 LED 亮起。系统处在 S1/S3 睡眠状态时, 此 LED 闪烁。系统处在 S4 睡眠状态或关机 (S5) 时, 此 LED 熄灭。

HDLED (硬盘活动指示灯):

连接到机箱前面板上的硬盘活动 LED 指示灯。硬盘正在读取或写入数据时, 此 LED 亮起。

前面板设计根据机箱不同而有所差异。前面板模块主要包括电源开关、重置开关、电源 LED、硬盘活动 LED 指示灯、扬声器等。将机箱前面板模块连接到此接脚时, 确保连线分配和针脚分配正确匹配。

串行 ATA3 接口

(SATA3_0:

见第 1 页, 第 16 个)

(SATA3_1:

见第 1 页, 第 15 个)

(SATA3_2:

见第 1 页, 第 17 个)

(SATA3_3:

见第 1 页, 第 9 个)

(SATA3_4:

见第 1 页, 第 8 个)

(SATA3_5:

见第 1 页, 第 6 个)

SATA3_5



SATA3_4



SATA3_3



SATA3_2



SATA3_1



SATA3_0



这六个 SATA3 接口支持最高 6.0 Gb/s 数据传输速率的内部存储设备的 SATA 数据线。SATA3_5 接口与 eSATA 端口共享; SATA3_4 接口与 mSATA/mini-PCIe 槽共享。

USB 2.0 接脚

(9 针 USB_2_3)

(见第 1 页, 第 21 个)

(9 针 USB_4_5)

(见针脚 1, 第 20 个)

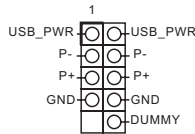

除 I/O 面板上的两个 USB 2.0 端口外, 此主板上还有两个接脚。每个 USB 2.0 接脚可以支持两个端口。

USB 3.0 接脚

(19 针 USB3_5_6)

(见第 1 页, 第 7 个)

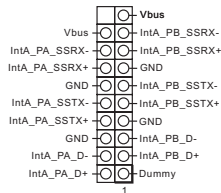

除 I/O 面板上的四个 USB 3.0 端口外, 此主板上还有一个接脚。每个 USB 3.0 接脚可以支持两个端口。

前面板音频接口
(9 针 HD_AUDIO1)
(见第 1 页, 第 21 个)

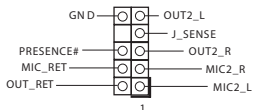

此接口用于将音频设备连接到前面板。



1. 高清音频支持插孔感测, 但机箱上的面板连线必须支持 HDA 才能正常工作。请按照我们的手册和机箱手册的说明安装系统。
2. 如果您使用 AC' 97 音频面板, 请按照以下步骤安装到前面板音频接口:
 - A. 将 Mic_IN (MIC) 连接到 MIC2_L.
 - B. 将 Audio_R (RIN) 连接到 OUT2_R, 将 Audio_L (LIN) 连接到 OUT2_L.
 - C. 将接地端 (GND) 连接到接地端 (GND)。
 - D. MIC_RET 和 OUT_RET 只用于高清音频面板。您不需要针对 AC' 97 音频面板连接它们。
 - E. 要启用前麦克风, 请转到 Realtek 控制面板上的“FrontMic” (前麦克风) 选项卡, 调整“Recording Volume” (录音音量)。

机箱扬声器接口
(4 针 SPEAKER1)
见第 1 页, 第 13 个)



请将机箱扬声器连接到此接口。

机箱和电源风扇接口
(4 针 CHA_FAN1)
见第 1 页, 第 4 个)

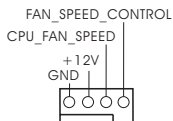

请将风扇线连接到风扇接口并使黑线匹配接地引脚。

CPU 风扇接口
(4 针 CPU_FAN1)
见第 1 页, 第 1 个)

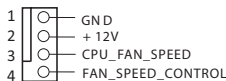

此主板提供 4 针 CPU 风扇 (静音风扇) 接口。如果您打算连接 3 针 CPU 风扇, 请将它连接到脚 1-3。

ATX 电源接口
(24 针 ATXPWR1)
(见第 1 页, 第 5 个)

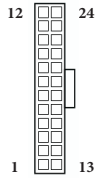

此主板提供 24 针 ATX 电源接口。要使用 20 针 ATX 电源, 请沿针脚 1 和针脚 13 插接它。

ATX 12V 电源接口
(8 针 ATX12V1)
(见第 1 页, 第 2 个)

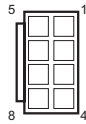

此主板提供 8 针 ATX 12V 电源接口。要使用 4 针 ATX 电源, 请沿针脚 1 和针脚 5 插接它。

机箱侵入接脚
(2 针 C11)
(见第 1 页, 第 11 个)



此主板支持 CASE OPEN (机箱打开) 检测功能 - 检测机箱盖是否拆下。此功能需要采用侵入检测设计的机箱。

TPM 接脚
(17 针 TPMS1)
(见第 1 页, 第 10 个)

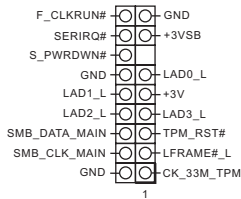

此接口支持 Trusted Platform Module (信任平台模块, TPM) 系统, 可以安全地存储密钥、数字证书、密码和数据。TPM 系统也可以帮助增强网络安全, 保护数字身份并确保平台完整性。

電子信息產品污染控制標示

依据中国发布的「电子信息产品污染控制管理办法」及 SJ/T 11364-2006「电子信息产品污染控制标示要求」，电子信息产品应进行标示，藉以向消费者揭露产品中含有的有毒有害物质或元素不致发生外泄或突变从而对环境造成污染或对人体、财产造成严重损害的期限。依上述规定，您可于本产品之印刷电路板上看见图一之标示。图一中之数字为产品之环保使用期限。由此可知此主板之环保使用期限为 10 年。



图一

有毒有害物質或元素的名稱及含量說明

若您欲了解此产品的有毒有害物质或元素的名称及含量说明，请参照以下表格及说明。

部件名称	有害物质或元素					
	铅 (Pb)	镉 (Cd)	汞 (Hg)	六价铬 (Cr (VI))	多溴联苯 (PBB)	多溴二苯醚 (PBDE)
印刷电路板及电子组件	X	O	O	O	O	O
外部信号连接头及线材	X	O	O	O	O	O

O: 表示该有毒有害物质在该部件所有均质材料中的含量均在 SJ/T 11363-2006 标准规定的限量要求以下。

X: 表示该有毒有害物质至少在该部件的某一均质材料中的含量超出 SJ/T 11363-2006 标准规定的限量要求，然该部件仍符合欧盟指令 2002/95/EC 的规范。

备注：此产品所标示之环保使用年限，系指在一般正常使用状况下。

1 簡介

感謝您購買 ASRock Z87E-ITX 主機板，本主機板經 ASRock 嚴格品質製作，是一套讓人信賴的可靠產品。本產品採耐用設計所展現的優異效能，完全符合 ASRock 對品質及耐用度的承諾。



由於主機板規格及 BIOS 軟體可能會更新，所以本文件內容如有變更，恕不另行通知。如本手冊有任何修改，可至 ASRock 網站逕行取得更新版本，不另外通知。若您需要與本主機板相關的技術支援，請上我們的網站瞭解有關您使用機型的特定資訊。您也可以到 ASRock 網站找到最新的 VGA 卡及 CPU 支援清單。ASRock 網站 <http://www.asrock.com>。

1.1 包裝內容

- ASRock Z87E-ITX 主機板 (Mini-ITX 尺寸)
- ASRock Z87E-ITX 快速安裝指南
- ASRock Z87E-ITX 支援光碟
- 4 x Serial ATA (SATA) 資料纜線 (選用)
- 1 x I/O 面板外罩
- 1 x ASRock WiFi 2.4GHz 天線
- 1 x DVI 轉 D-Sub 轉換器

1.2 規格

- 平台
- Mini-ITX 尺寸
 - 黃金級電容設計 (100% 日本製高品質固態高分子電容)

- CPU
- 支援第 4 代 Intel® Core™ i7 / i5 / i3 / Xeon® / Pentium® / Celeron® (LGA1150 封裝)
 - 數位電源設計
 - 6 電源相位設計
 - DrMOS
 - 支援 Intel® Turbo Boost 2.0 技術
 - 支援 Intel® K-Series unlocked CPU

- 晶片組
- Intel® Z87

- 記憶體
- 雙通道 DDR3 記憶體技術
 - 2 x DDR3 DIMM 插槽
 - 支援 DDR3 2933+(OC)/2800(OC)/2400(OC)/2133(OC)/1866(OC)/1600/1333/1066 非 ECC、無緩衝記憶體
 - 最大系統記憶體容量：16GB (請參閱「注意」)
 - 支援 Intel® Extreme Memory Profile (XMP)1.3/1.2

- 擴充插槽
- 1 x PCI Express 3.0 x16 插槽
 - 1 x 半迷你 PCI Express 插槽：適用於 WiFi + BT 模組
 - 1 x mSATA / 全迷你 PCI Express 插槽

- 顯示卡
- 僅限整合 GPU 的處理器才可支援 Intel® HD Graphics Built-in Visuals 及 VGA 輸出。
 - 支援 Intel® HD Graphics Built-in Visuals：轉換 AVC、MVC (S3D) 及 MPEG-2 Full HW Encode1 的 Intel® 高速影像同步轉檔技術、Intel® InTru™ 3D、Intel® Clear Video HD Technology、Intel® Insider™、Intel® HD Graphics 4400/4600
 - Pixel Shader 5.0、DirectX 11.1
 - 最大共用記憶體 1792MB

- 三個 VGA 輸出選項：DVI-I、HDMI 及 DisplayPort
- 支援三台顯示器
- 支援最高達 4K × 2K (4096x2304) @ 24Hz 解析度的 HDMI 技術
- 支援最高達 1920x1200 @ 60Hz 解析度的 DVI-I
- 支援最高達 3840x2160 @ 60Hz 解析度的 DisplayPort
- 支援使用 HDMI (需相容於 HDMI 監視器) 的 Auto Lip Sync、Deep Color (12bpc)、xvYCC 及 HBR (高位元率音訊)
- 支援含 DVI-I、HDMI 及 DisplayPort 連接埠的 HDCP 功能
- 支援透過 DVI-I、HDMI 及 DisplayPort 連接埠的 Full HD 1080p Blu-ray (BD) / HD-DVD 播放

音訊

- 7.1 CH HD 音訊含內容保護 (Realtek ALC1150 音訊轉碼器) 功能
- 高階藍光音訊支援
- TI* NE5532 (支援最高 600 Ohms 的 Premium Headset Amplifier)
- 支援 DTS Connect

LAN

- Gigabit LAN 10/100/1000 Mb/s
- Giga PHY Intel® I217V
- 支援 Intel® 遠端喚醒技術
- 支援網路喚醒
- 支援 Energy Efficient Ethernet 802.3az
- 支援 PXE

無線 LAN

- 支援 IEEE 802.11a/b/g/n/ac
- 支援雙頻 (2.4/5 GHz)
- 支援高達 867Mbps 的高速無線連線
- 2 天線支援 2 (傳送) x 2 (接收) 分集技術
- 支援 Bluetooth 4.0 / 3.0 + 高速級別 II

後面板 I/O

- 1 x PS/2 滑鼠／鍵盤連接埠
- 1 x DVI-I 連接埠
- 1 x HDMI 連接埠
- 1 x DisplayPort
- 1 x 光纖 SPDIF 輸出連接埠
- 1 x eSATA 接頭
- 2 x USB 2.0 連接埠
- 4 x USB 3.0 連接埠
- 1 x RJ-45 LAN 連接埠，含 LED (ACT/LINK LED 及 SPEED LED)
- 1 x 清除 CMOS 開關
- HD 音訊插孔：後置喇叭／中置／低音／線路輸入／前置喇叭／麥克風

儲存裝置

- 6 x SATA3 6.0 Gb/s 接頭，支援 RAID (RAID 0、RAID 1、RAID 5、RAID 10、Intel 快速儲存技術 12 及 Intel 智慧反應技術)、NCQ、AHCI 及「熱插拔」(SATA3_5 接頭與 eSATA 連接埠共用；SATA3_4 接頭與 mSATA/mini-PCI Express 插槽共用)
- 1 x eSATA 接頭，支援 NCQ、AHCI 及「熱插拔」功能
- 1 x mSATA 6.0 Gb/s 接頭 (固態磁碟接頭)，支援 NCQ、AHCI 功能及全尺寸 mini-PCI Express 模組

接頭

- 1 x 機殼防護標頭
- 1 x TPM 標頭
- 1 x CPU 風扇接頭 (4-pin)
- 1 x 機殼風扇接頭 (4-pin)
- 1 x 24 pin ATX 電源接頭
- 1 x 8 pin 12V 電源接頭 (高密度電源接頭)
- 1 x 前面板音訊接頭
- 2 x USB 2.0 標頭 (支援 4 USB 2.0 連接埠)
- 1 x USB 3.0 標頭 (支援 2 USB 3.0 連接埠)

BIOS 功能

- 64Mb AMI UEFI Legal BIOS 含多語 GUI 支援
- ACPI 1.1 符合喚醒自動開機
- 支援 SMBIOS 2.3.1
- CPU、DRAM、PCH 1.05V、PCH 1.5V 電壓多重調整

支援 CD

- 驅動程式、公用程式、防毒軟體（試用版）、CyberLink MediaEspresso 6.5 Trial、Google Chrome 瀏覽器及工具列、Start8、MeshCentral、Splashtop Streamer、Intel® Extreme Tuning Utility (XTU)

硬體監視器

- CPU / 機殼溫度感應
- CPU / 機殼轉速計
- CPU / 機殼靜音風扇（允許按照 CPU 溫度自動調整機殼風扇速度）
- CPU / 機殼風扇多重速度控制
- 電壓監控：+12V、+5V、+3.3V、CPU Vcore

作業系統

- 相容 Microsoft® Windows® 8 / 8 64 位元 / 7 / 7 64 位元

認證

- FCC、CE、WHQL
- ErP/EuP Ready（需具備 ErP/EuP ready 電源供應器）

* 如需產品詳細資訊，請上我們的網站：<http://www.asrock.com>



請務必理解，超頻可能產生某種程度的風險，其中包括調整 BIOS 中的設定、採用自由超頻技術或使用協力廠商的超頻工具。超頻可能會影響您系統的穩定性，或者甚至會對您系統的元件及裝置造成傷害。您應自行負擔超頻風險及成本。我們對於因超頻所造成的可能損害概不負責。



在 Windows® 32 位元作業系統下，因有保留供系統使用記憶體的限制，所以實際記憶體大小可能低於 4GB。Windows® 64 位元作業系統則沒有此類限制。您可使用 ASRock XFast RAM 運用 Windows® 無法使用的記憶體。

1.3 跳線設定

圖例顯示設定跳線的方式。跳線蓋套在針腳上時，該跳線為「短路」。若沒有跳線蓋套在針腳上，該跳線為「開啟」。

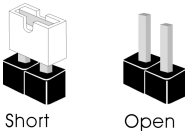

Short

Open

清除 CMOS 跳線

(CLR CMOS1)

(請參閱第 1 頁，編號 14)



2-pin 跳線

短路：清除 CMOS

開啟：預設

您可利用 CLR CMOS1 清除 CMOS 中的資料。CMOS 中的資料包含系統設定資訊，如系統密碼、日期、時間及系統設定參數。若要清除並重設系統參數為預設設定，請先關閉電腦電源及拔下電源線，然後使用跳線蓋讓 CLR CMOS1 上的針腳短路約 3 秒。請牢記，務必在清除 CMOS 後取下跳線蓋。若您需在更新 BIOS 後立即清除 CMOS，則必須先重新啟動系統，然後於進行清除 CMOS 動作前關機。



1. 清除 CMOS 開關擁有與清除 CMOS 跳線相同的功能。
2. 若您清除 CMOS，可能會偵測到機殼開啟。請調整 BIOS 選項「清除狀態」，清除先前機殼防護狀態的紀錄。

1.4 板載標頭及接頭



板載標頭及接頭都不是跳線，請勿將跳線蓋套在這些標頭及接頭上。將跳線蓋套在標頭及接頭上，將造成主機板永久性的受損。

系統面板標頭
(9-pin PANEL)
(請參閱第 1 頁，編號 12)

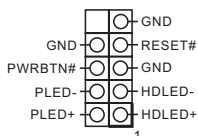

請依照以下的針腳排列將機殼上的電源開關、重設開關及系統狀態指示燈連接至此標頭。在連接纜線之前，請注意正負針腳。



PWRBTN (電源開關) :

連接至機殼前面板上的電源開關。您可設定使用電源開關關閉系統電源的方式。

RESET (重設開關) :

連接至機殼前面板上的重設開關。若電腦凍結且無法執行正常重新啟動，按下重設開關即可重新啟動電腦。

PLED (系統電源 LED) :

連接至機殼前面板上的電源狀態指示燈。系統正在運作時，此 LED 會亮起。系統進入 S1/S3 睡眠狀態時，LED 會持續閃爍。系統進入 S4 睡眠狀態或關機 (S5) 時，LED 會熄滅。

HDLED (硬碟活動 LED) :

連接至機殼前面板上的硬碟活動 LED。硬碟正在讀取或寫入資料時，LED 會亮起。

各機殼的前面板設計各有不同。前面板模組主要是由電源開關、重設開關、電源 LED、硬碟活動 LED、喇叭及其他裝置組成。將機殼前面板模組連接至此標頭時，請確定佈線及針腳指派皆正確相符。

Serial ATA3 接頭

- (SATA3_0:
請參閱第 1 頁, 編號 16)
- (SATA3_1:
請參閱第 1 頁, 編號 15)
- (SATA3_2:
請參閱第 1 頁, 編號 17)
- (SATA3_3:
請參閱第 1 頁, 編號 9)
- (SATA3_4:
請參閱第 1 頁, 編號 8)
- (SATA3_5:
請參閱第 1 頁, 編號 6)



這六組 SATA3 接頭皆支援內部儲存裝置的 SATA 資料纜線, 最高可達 6.0 Gb/s 資料傳輸率。SATA3_5 接頭與 eSATA 連接埠共用; SATA3_4 接頭與 mSATA/mini-PCIe 插槽共用。

USB 2.0 標頭

- (9-pin USB_2_3)
(請參閱第 1 頁, 編號 21)
- (9-pin USB_4_5)
(請參閱第 1 頁, 編號 20)

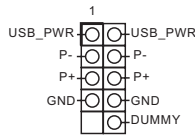

除了 I/O 面板上的兩個 USB 2.0 連接埠外, 在本主機板上還有另外兩組標頭。各 USB 2.0 標頭皆可支援兩個連接埠。

USB 3.0 標頭

- (19-pin USB3_5_6)
(請參閱第 1 頁, 編號 7)

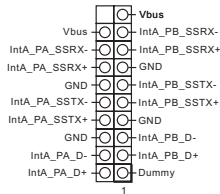

除了 I/O 面板上的四個 USB 3.0 連接埠外, 在本主機板上還有另外一組標頭。各 USB 3.0 標頭皆可支援兩個連接埠。

前面板音訊標頭

(9-pin HD_AUDIO1)

(請參閱第 1 頁, 編號 1)

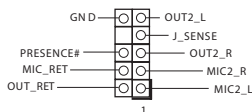

本標頭適用於連接音訊裝置至前面板音訊。



1. 高解析度音訊支援智慧型音效介面偵測 (Jack Sensing), 但機殼上的面板線必須支援 HDA 才能正確運作。請依本手冊及機殼手冊說明安裝系統。
2. 若您使用 AC' 97 音訊面板, 請按照以下步驟安裝至前面板音訊標頭:
 - A. 將 Mic_IN (MIC) 連接至 MIC2_L。
 - B. 將 Audio_R (RIN) 連接至 OUT2_R 且將 Audio_L (LIN) 連接至 OUT2_L。
 - C. 將接地 (GND) 連接至接地 (GND)。
 - D. MIC_RET 及 OUT_RET 僅供 HD 音訊面板使用。您不需要在 AC' 97 音訊面板上連接。
 - E. 若要啟動前側麥克風, 請前往 Realtek 控制面板中的「FrontMic」標籤調整「錄音音量」。

機殼喇叭標頭

(4-pin SPEAKER1)

(請參閱第 1 頁, 編號 13)



請將機殼喇叭連接至此標頭。

機殼及電源風扇接頭

(4-pin CHA_FAN1)

(請參閱第 1 頁, 編號 4)

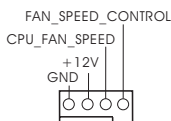

請將風扇纜線連接至風扇接頭, 並比對黑線及接地針腳。

CPU 風扇接頭

(4-pin CPU_FAN1)

(請參閱第 1 頁, 編號 1)

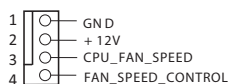

本主機板配備 4-Pin CPU 風扇 (靜音風扇) 接頭。若您計畫連接 3-Pin CPU 風扇, 請接至 Pin 1-3。

ATX 電源接頭
(24-pin ATXPWR1)
(請參閱第 1 頁, 編號 5)

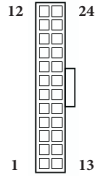

本主機板配備一組 24-pin ATX 電源接頭。若要使用 20-pin ATX 電源供應器, 請插入 Pin 1 及 Pin 13。

ATX 12V 電源接頭
(8-pin ATX12V1)
(請參閱第 1 頁, 編號 2)

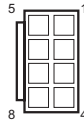

本主機板配備一組 8-pin ATX 12V 電源接頭。若要使用 4-pin ATX 電源供應器, 請插入 Pin 1 及 Pin 5。

機殼防護標頭
(2-pin CI1)
(請參閱第 1 頁, 編號 11)



本主機板支援「機殼開啟」偵測功能, 可偵測機殼外蓋是否遭移除。若要使用本功能, 機殼必須採用機殼防護偵測設計。

TPM 標頭
(17-pin TPMS1)
(請參閱第 1 頁, 編號 10)

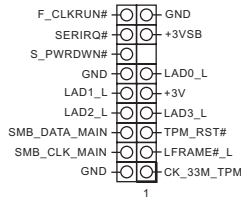

此接頭支援信賴平台模組 (TPM) 系統, 可確保儲存金鑰、數位憑證、密碼及資料的安全。TPM 系統也能強化網路安全、保護數位身分並穩定平台完整性。

1 Pendahuluan

Terima kasih telah membeli motherboard ASRock Z87E-ITX, yakni motherboard andal yang diproduksi di bawah kendali mutu ketat yang sejalan dengan ASRock. Motherboard ini memberikan performa luar biasa dengan desain canggih yang meneguhkan komitmen ASRock terhadap kualitas dan ketahanan.



Karena spesifikasi motherboard dan perangkat lunak BIOS dapat di-update, maka isi dokumentasi ini akan berubah sewaktu-waktu tanpa pemberitahuan sebelumnya. Jika terdapat perubahan pada panduan pengguna ini, maka versi baru akan tersedia di situs web ASRock tanpa pemberitahuan lebih lanjut. Jika Anda memerlukan dukungan teknis terkait motherboard ini, kunjungi situs web kami untuk mendapatkan informasi khusus tentang model yang Anda gunakan. Anda juga dapat menemukan kartu VGA dan daftar dukungan CPU terkini di situs web ASRock. Situs web ASRock <http://www.asrock.com>.

1.1 Isi Kemasan

- Motherboard ASRock Z87E-ITX (Bentuk dan Ukuran Mini-ITX)
- Panduan Ringkas ASRock Z87E-ITX
- CD Dukungan ASRock Z87E-ITX
- 4 x Kabel Data SATA (Serial ATA) (Opsional)
- 1 x Pelindung Panel I/O
- 1 x Antena WiFi 2,4GHz ASRock
- 1 x Konverter DVI-ke-D-Sub

1.2 Spesifikasi

Platform

- Bentuk dan Ukuran Mini-ITX
- Desain Premium Gold Capacitor (100% Kapasitor Polimer Konduktif berkualitas tinggi buatan Jepang)

CPU

- Mendukung Intel® Core™ i7 / i5 / i3 Generasi Ke-4 / Xeon® / Pentium® / Celeron® dalam Paket LGA1150
- Desain Digi Power
- Desain 6 Fase Daya
- DrMOS
- Mendukung Teknologi Intel® Turbo Boost 2.0
- Mendukung CPU Intel® K-Series unlocked

Chipset

- Intel® Z87

Memori

- Teknologi Memori DDR3 Kanal Ganda
- 2 x Slot DDR3 DIMM
- Mendukung DDR3 2933+(OC)/2800(OC)/2400(OC)/2133(OC)/1866(OC)/1600/1333/1066 non-ECC, memori tanpa buffer
- Kapasitas maksimum memori sistem: 16GB (lihat PERHATIAN)
- Mendukung Intel® Extreme Memory Profile (XMP)1.3/1.2

Slot Ekspansi

- 1 x Slot PCI Express 3.0 x16
- 1 x Slot mini-PCI Express separuh: Untuk modul WiFi + BT
- 1 x Slot mSATA/mini-PCI Express penuh

Grafis

- Intel® HD Graphics Built-in Visuals dan output VGA hanya didukung dengan prosesor yang terintegrasi GPU.
- Mendukung Intel® HD Graphics Built-in Visuals: Intel® Quick Sync Video dengan AVC, MVC (S3D), dan MPEG-2 Full HW Encode1, Intel® InTru™ 3D, Teknologi Intel® Clear Video HD, Intel® Insider™, Intel® HD Graphics 4400/4600
- Pixel Shader 5.0, DirectX 11.1
- Memori bersama maksimum 1792MB

- Tiga pilihan output VGA: DVI-I, HDMI, dan DisplayPort
- Mendukung Tiga Monitor
- Mendukung Teknologi HDMI dengan resolusi maksimum hingga 4K × 2K (4096x2304) @ 24Hz
- Mendukung DVI-I dengan resolusi maksimum hingga 1920x1200 @ 60Hz
- Mendukung DisplayPort dengan resolusi maksimum hingga 3840x2160 @ 60Hz
- Mendukung Auto Lip Sync, Deep Color (12bpc), xvYCC, dan HBR (High Bit Rate Audio) dengan HDMI (memerlukan monitor HDMI yang kompatibel)
- Mendukung fungsi HDCP dengan port DVI-I, HDMI, dan DisplayPort
- Mendukung pemutaran Full HD 1080p Blu-ray (BD) / HD-DVD dengan port DVI-I, HDMI, dan DisplayPort

Audio

- Audio HD 7.1 CH dengan Perlindungan Konten (Realtek ALC1150 Audio Codec)
- Mendukung audio Blu-ray premium
- TI® NE5532 (mendukung Premium Headset Amplifier hingga 600 Ohms)
- Mendukung DTS Connect

LAN

- Gigabit LAN 10/100/1000 Mb/s
- Giga PHY Intel® I217V
- Mendukung Teknologi Intel® Remote Wake
- Mendukung Wake-On-LAN
- Mendukung Energy Efficient Ethernet 802.3az
- Mendukung PXE

LAN Nirkabel

- Mendukung IEEE 802.11a/b/g/n/ac
- Mendukung Dual-Band (2,4/5 GHz)
- Mendukung sambungan nirkabel berkecepatan tinggi hingga 867Mbps
- 2 antena untuk mendukung teknologi ragam industri 2 (Transmisi) x 2 (Terima)
- Mendukung Bluetooth 4.0 / 3.0 + Kecepatan tinggi kelas II

Panel I/O Belakang

- 1 x Port Mouse/Keyboard PS/2
- 1 x Port DVI-I
- 1 x Port HDMI
- 1 x DisplayPort
- 1 x Port SPDIF Out Optik
- 1 x Konektor eSATA
- 2 x Port USB 2.0
- 4 x Port USB 3.0
- 1 x Port LAN RJ-45 dengan LED (ACT/LINK LED dan SPEED LED)
- 1 x Clear CMOS Switch
- Soket Audio HD: Speaker Belakang/Tengah/Bas/Saluran masuk/Speaker Depan/Mikrofon

Penyimpanan

- 6 x Konektor SATA3 6,0 Gb/s, mendukung RAID (RAID 0, RAID 1, RAID 5, RAID 10, Teknologi Intel Rapid Storage 12, dan Teknologi Intel Smart Response), NCQ, AHCI, dan “Hot Plug” (konektor SATA3_5 digunakan bersama port eSATA; konektor SATA3_4 digunakan bersama slot mSATA/mini-PCI Express)
- 1 x Konektor eSATA, mendukung fungsi NCQ, AHCI, dan “Hot Plug”
- 1 x Konektor mSATA 6,0 Gb/s (konektor Solid-State Drive), mendukung fungsi NCQ, AHCI, dan modul mini-PCI Express ukuran penuh

Konektor

- 1 x Header Intrusi Chassis
- 1 x Header TPM
- 1 x Konektor kipas CPU (4-pin)
- 1 x Konektor kipas chassis (4-pin)
- 1 x Konektor daya ATX 24 pin
- 1 x Konektor daya 12V 8 pin (Konektor Daya dengan Kerapatan Tinggi)
- 1 x Konektor audio panel depan
- 2 x Header USB 2.0 (mendukung 4 port USB 2.0)
- 1 x Header USB 3.0 (mendukung 2 port USB 3.0)

Fitur BIOS

- 64Mb AMI UEFI Legal BIOS dengan dukungan GUI Multibahasa
- ACPI 1.1 Kompatibel dengan Aktivitas Pengaktifan
- Dukungan SMBIOS 2.3.1
- Multipengatur Tegangan CPU, DRAM, PCH 1,05V, PCH 1,5V

Dukungan CD

- Driver, Utilitas, Perangkat Lunak AntiVirus (Versi Uji Coba), CyberLink MediaEspresso 6.5 Uji Coba, Google Chrome Browser dan Toolbar, Start8, MeshCentral, Splashtop Streamer, Intel® Extreme Tuning Utility (IXTU)

Perangkat**Keras Monitor**

- Sensor Suhu CPU/Chassis
- Takometer CPU/Chassis
- Kipas Hening CPU/Chassis (Memungkinkan Penyesuaian Otomatis Kecepatan Kipas Chassis Berdasarkan Suhu CPU)
- Kontrol Multikecepatan Kipas CPU/Chassis
- Pemantauan Tegangan: +12V, +5V, +3,3V, CPU Vcore

OS

- Kompatibel dengan Microsoft® Windows® 8 / 8 64-bit / 7 / 7 64-bit

Sertifikasi

- FCC, CE, WHQL
- Siap untuk ErP/EuP (memerlukan catu daya untuk ErP/EuP)

* Untuk informasi tentang produk rinci, kunjungi situs web kami: <http://www.asrock.com>



Perlu diketahui, overclocking memiliki risiko tertentu, termasuk menyesuaikan pengaturan pada BIOS, menerapkan Teknologi Untied Overclocking, atau menggunakan alat overclocking pihak ketiga. Overclocking dapat mempengaruhi stabilitas sistem, atau bahkan dapat mengakibatkan kerusakan komponen dan perangkat sistem. Risiko dan biaya apapun menjadi tanggungan Anda. Kami tidak bertanggung jawab atas kemungkinan kerusakan karena overclocking.



Karena keterbatasan, ukuran memori sebenarnya mungkin kurang dari 4GB karena akan digunakan sistem berdasarkan sistem operasi Windows® 32-bit. Sistem operasi Windows® 64-bit tidak memiliki keterbatasan tersebut. Anda dapat menggunakan ASRock XFast RAM untuk memanfaatkan memori yang tidak dapat digunakan Windows® tersebut.

1.3 Konfigurasi Jumper

Gambar menunjukkan cara mengkonfigurasi jumper. Bila penutup jumper diletakkan pada pin, maka jumper akan “Pendek”. Jika tidak ada penutup jumper yang diletakkan pada pin, maka jumper akan “Terbuka”.

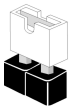

Short



Open

Clear CMOS Jumper
(CLR CMOS1)
(lihat hal. 1, No. 14)



Jumper 2-pin

Pendek: Clear CMOS
Terbuka: Default

CLR CMOS1 memungkinkan Anda mengosongkan data di CMOS. Data pada CMOS mencakup informasi konfigurasi sistem, seperti sandi sistem, tanggal, waktu, dan parameter konfigurasi sistem. Untuk mengosongkan dan mengatur ulang parameter ke konfigurasi default, matikan komputer dan lepas kabel daya, lalu gunakan penutup jumper untuk memendekkan pin pada CLR CMOS1 selama 3 detik. Pastikan untuk melepas penutup jumper setelah mengosongkan CMOS. Jika Anda harus mengosongkan CMOS setelah selesai meng-update BIOS, boot up dulu sistem, lalu matikan sebelum melakukan tindakan clear-CMOS.



1. Switch Clear CMOS memiliki fungsi yang sama seperti Clear CMOS jumper.
2. Jika Anda mengosongkan CMOS, maka rangka terbuka mungkin akan terdeteksi. Atur pilihan “Clear Status” BIOS untuk mengosongkan data status intrusi chassis sebelumnya.

1.4 Header dan Konektor Onboard



Header dan konektor terpasang **BUKANLAH jumper**. **JANGAN** letakkan penutup jumper pada header dan konektor tersebut. Meletakkan penutup jumper pada header dan konektor akan mengakibatkan kerusakan permanen pada motherboard.

Header Panel Sistem
(PANEL1 9-pin)
(lihat hal. 1, No. 12)

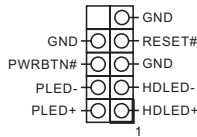

Sambungkan switch daya, atur ulang indikator status sistem dan switch daya pada chassis ke header tersebut berdasarkan penetapan pin di bawah ini. Perhatikan pin positif dan negatif sebelum menyambungkan kabel.



PWRBTN (Switch Daya):

Sambungkan ke switch daya pada panel depan chassis. Anda dapat mengkonfigurasi cara mematikan sistem menggunakan switch daya.

RESET (Switch Atur Ulang):

Sambungkan switch atur ulang pada panel depan chassis. Tekan switch atur ulang untuk mengatur ulang komputer jika komputer tidak merespons dan gagal melakukan pengaktifan ulang normal.

PLED (LED Daya Sistem):

Sambungkan ke indikator status daya pada panel depan chassis. LED akan menyala bila sistem sedang beroperasi. LED akan terus berkedip bila sistem dalam kondisi tidur S1/S3. LED akan mati bila sistem dalam kondisi tidur S4 atau mati (S5).

HDLED (LED Aktivitas Hard Drive):

Sambungkan ke LED aktivitas hard drive pada panel depan chassis. LED akan menyala bila hard drive sedang membaca atau menulis data.

Desain panel depan dapat berbeda menurut chassis. Modul panel depan biasanya terdiri atas switch daya, switch atur ulang, LED daya, LED aktivitas hard drive, speaker, dll. Bila menyambungkan modul panel depan chassis ke header, pastikan penetapan kabel dan pin disesuaikan dengan benar.

Konektor Serial ATA3

(SATA3_0:
lihat hal. 1, No. 16)
(SATA3_1:
lihat hal. 1, No. 15)
(SATA3_2:
lihat hal. 1, No. 17)
(SATA3_3:
lihat hal. 1, No. 9)
(SATA3_4:
lihat hal. 1, No. 8)
(SATA3_5:
lihat hal. 1, No. 6)



Keenam konektor SATA3 ini mendukung kabel data SATA untuk perangkat penyimpanan internal dengan kecepatan transfer data hingga 6,0 Gb/s. Konektor SATA3_5 digunakan bersama port eSATA; konektor SATA3_4 digunakan bersama slot mSATA/mini-PCIe.

Header USB 2.0

(USB_2_3 9-pin)
(lihat hal. 1, No. 21)
(USB_4_5 9-pin)
(lihat hal. 1, No. 20)

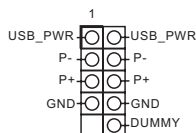

Selain dua port USB 2.0 pada panel I/O, terdapat dua header pada motherboard ini. Masing-masing header USB 2.0 dapat mendukung dua port.

Header USB 3.0

(USB3_5_6 19-pin)
(lihat hal. 1, No. 7)

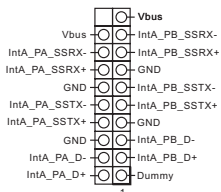

Selain empat port USB 3.0 pada panel I/O, terdapat satu header pada motherboard ini. Masing-masing header USB 3.0 dapat mendukung dua port.

Header Audio Panel
Depan
(HD_AUDIO1 9-pin)
(lihat hal. 1, No. 21)

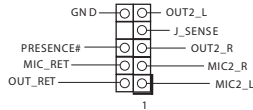

Header ini untuk menyambungkan perangkat audio ke panel audio depan.



1. Audio Definisi Tinggi mendukung Sensor Soket, namun kabel panel pada chassis harus mendukung HDA agar berfungsi dengan benar. Ikuti petunjuk dalam panduan pengguna ini dan panduan pengguna chassis untuk menginstal sistem.
2. Jika Anda menggunakan panel audio AC'97, pasang ke header audio panel depan dengan melakukan langkah-langkah di bawah ini:
 - A. Sambungkan Mic_IN (MIC) ke MIC2_L.
 - B. Sambungkan Audio_R (RIN) ke OUT2_R dan Audio_L (LIN) ke OUT2_L.
 - C. Sambungkan Ground (GND) ke Ground (GND).
 - D. MIC_RET dan OUT_RET hanya untuk panel audio HD. Anda tidak perlu menyambungkannya untuk panel audio AC'97.
 - E. Untuk mengaktifkan mikrofon depan, buka tab "FrontMic" pada Panel kontrol Realtek, lalu sesuaikan "Volume Perekaman".

Header Speaker Chassis
(SPEAKER1 4-pin)
(lihat hal. 1, No. 13)

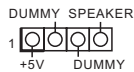

Sambungkan speaker chassis ke header ini.

Konektor Kipas Chassis dan Daya
(CHA_FAN1 4-pin)
(lihat hal. 1, No. 4)

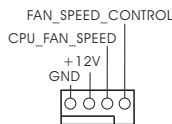

Sambungkan kabel kipas ke konektor kipas, lalu cocokkan kabel hitam dengan pin ground.

Konektor Kipas CPU
(CPU_FAN1 4-pin)
(lihat hal. 1, No. 1)

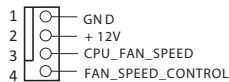

Motherboard ini memberikan konektor kipas CPU 4-Pin (Kipas Hening). Jika Anda berencana untuk menyambungkan kipas CPU 3-Pin, sambungkan ke Pin 1-3.

Konektor Daya ATX
(ATXPWR1 24-pin)
(lihat hal. 1, No. 5)

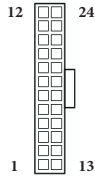

Motherboard ini memberikan konektor daya ATX 24-pin. Untuk menggunakan catu daya ATX 20-pin, pasang bersama Pin 1 dan Pin 13.

Konektor Daya ATX 12V
(ATX12V1 8-pin)
(lihat hal. 1, No. 2)

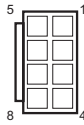

Motherboard ini memberikan konektor daya ATX 12V 8-pin. Untuk menggunakan catu daya ATX 4-pin, pasang bersama Pin 1 dan Pin 5.

Header Intrusi Chassis
(CII 2-pin)
(lihat hal. 1, No. 11)



Motherboard ini mendukung Fitur deteksi CASE OPEN yang mendeteksi jika celah chassis telah dilepas. Fitur ini memerlukan chassis dengan desain deteksi intrusi chassis.

Header TPM
(TPMS1 17-pin)
(lihat hal. 1, No. 10)

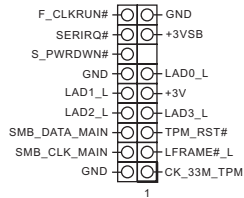

Konektor ini mendukung sistem TPM (Trusted Platform Module), yang dapat menyimpan kode kunci, sertifikat digital, sandi, dan data secara aman. Sistem TPM juga membantu meningkatkan keamanan jaringan, melindungi identitas digital, dan memastikan integritas platform.

Contact Information

If you need to contact ASRock or want to know more about ASRock, you're welcome to visit ASRock's website at <http://www.asrock.com>; or you may contact your dealer for further information. For technical questions, please submit a support request form at <http://www.asrock.com/support/tsd.asp>

ASRock Incorporation

2F., No.37, Sec. 2, Jhongyang S. Rd., Beitou District,

Taipei City 112, Taiwan (R.O.C.)

ASRock EUROPE B.V.

Bijsterhuizen 3151

6604 LV Wijchen

The Netherlands

Phone: +31-24-345-44-33

Fax: +31-24-345-44-38

ASRock America, Inc.

13848 Magnolia Ave, Chino, CA91710

U.S.A.

Phone: +1-909-590-8308

Fax: +1-909-590-1026