

# Occa

Design by BoConcept

Samvejledning - Assembly Instructions - Montageanleitung - Instructions d'assemblage - Instrucciones de montaje



**672**

11,6x102,5x70,3 cm /  max. 60 kg



Korpus - Korpus - Carcase - Carcasse

col. 1

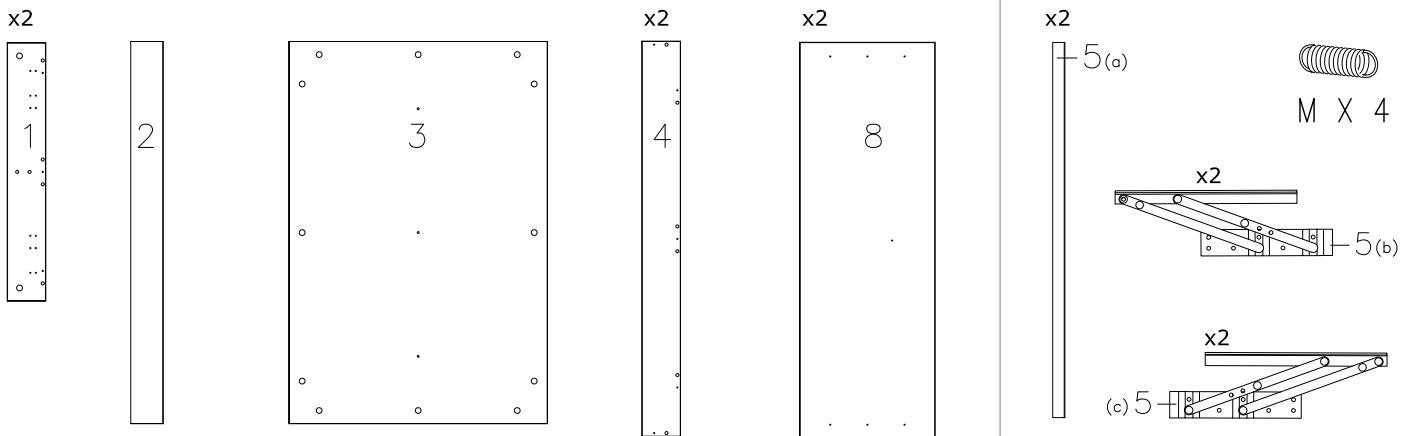

Beslag - Beschl ag - Fittings - Set de montage

col. 1



**A X 16**  
1972000009



**B X 24**  
1979110830  
7,8x30



**C X 16**  
1972000014



**D X 3**  
970000611  
4,2x45mm



**E X 4**  
970000712



**F X 36**  
970000786  
4,0x16mm



**G X 8**  
970000656  
M5x16mm



**H X 1**  
1979300003  
3mm



**J X 2**  
970000768

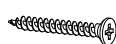

**K X 2**  
1978004530  
4,5x30 mm



**L X 12**  
1979000000

Verkt j  
Werkzeuge  
Tools  
Outils

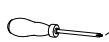
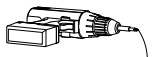

FIG. 1

Attention!

- A X 3
- B X 2
- 7,8x30

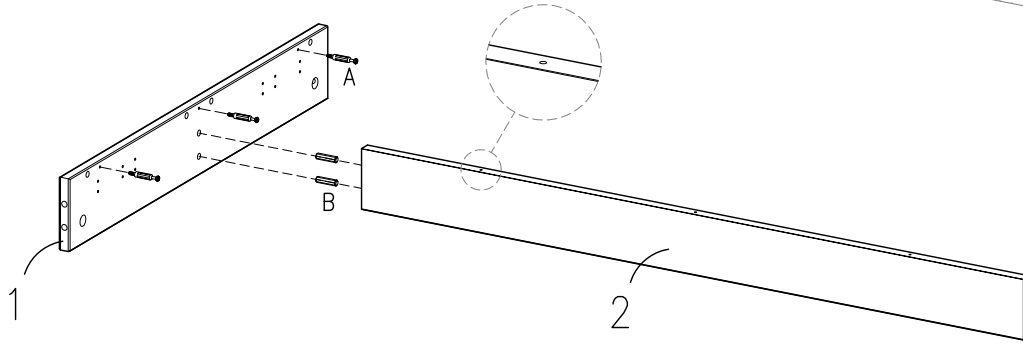

FIG. 2

- B X 4
- C X 3
- 7,8x30

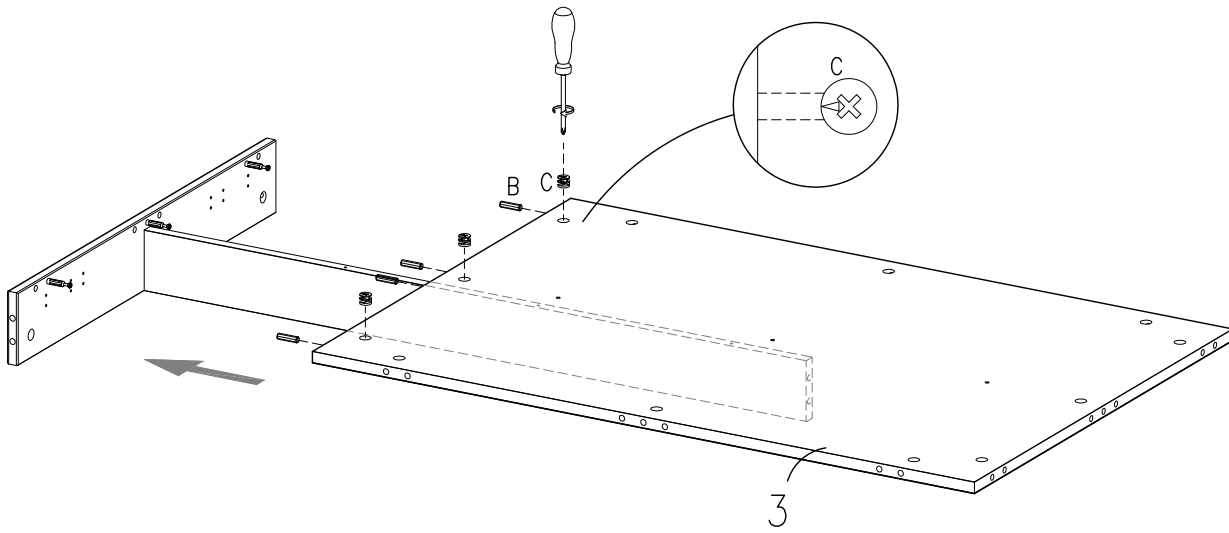

FIG. 3

- A X 3
- B X 6
- C X 3
- 7,8x30

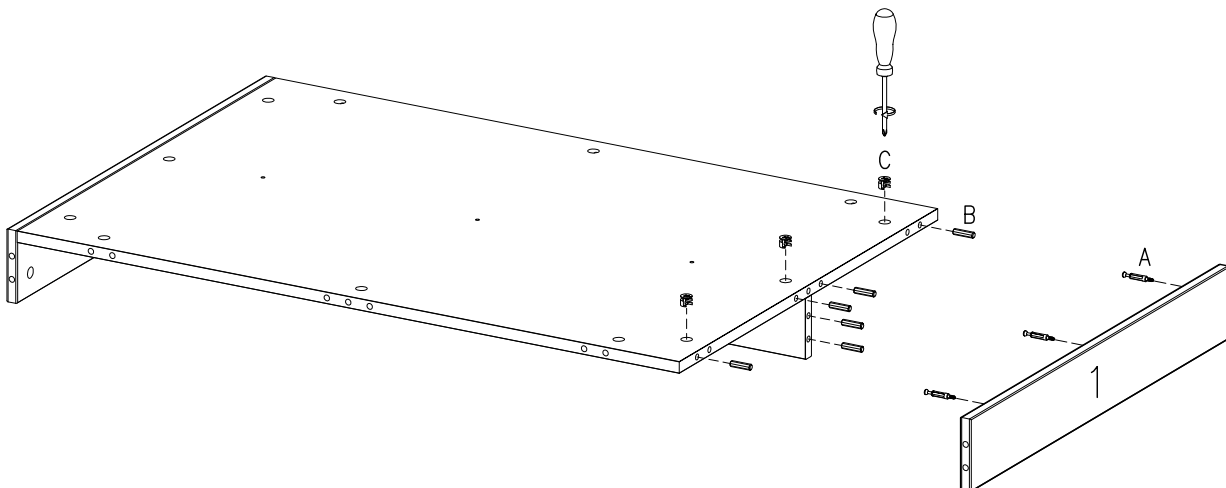

FIG. 4

D X 3  
4,2x45mm

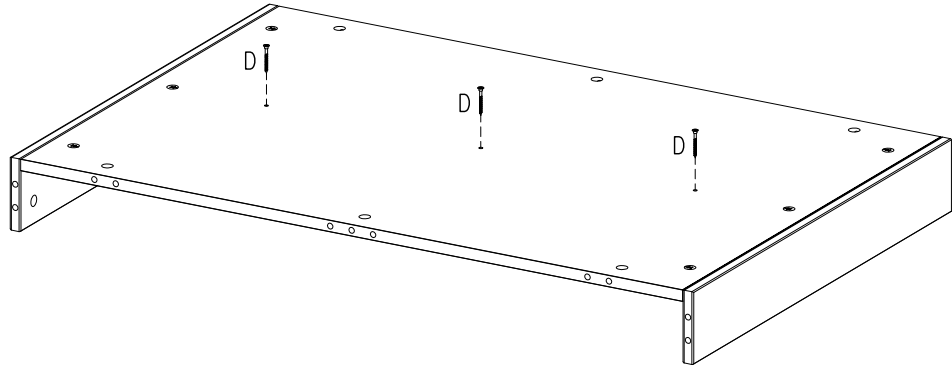

FIG. 5

A X 5    B X 6  
7,8x30    C X 5    E X 2

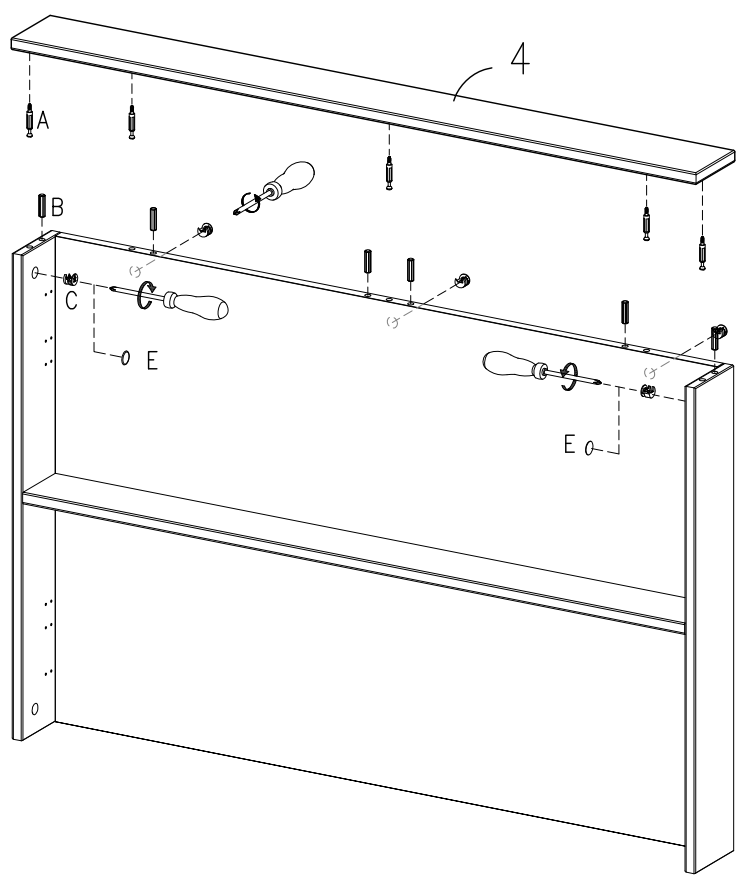





FIG. 6

-   
 A X 5
-   
 B X 6  
7,8x30
-   
 C X 5
-   
 E X 2

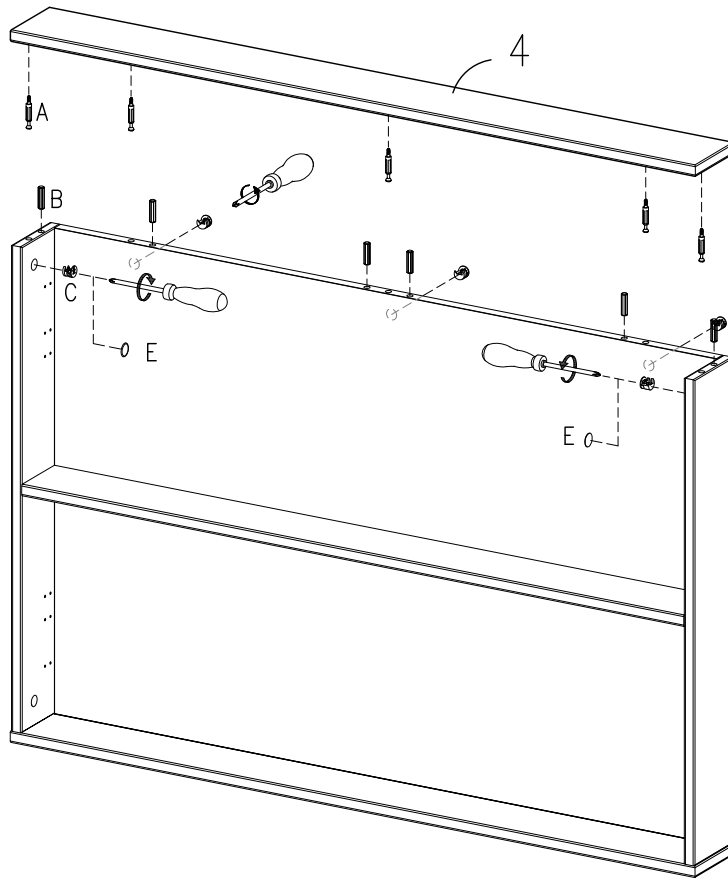
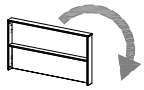
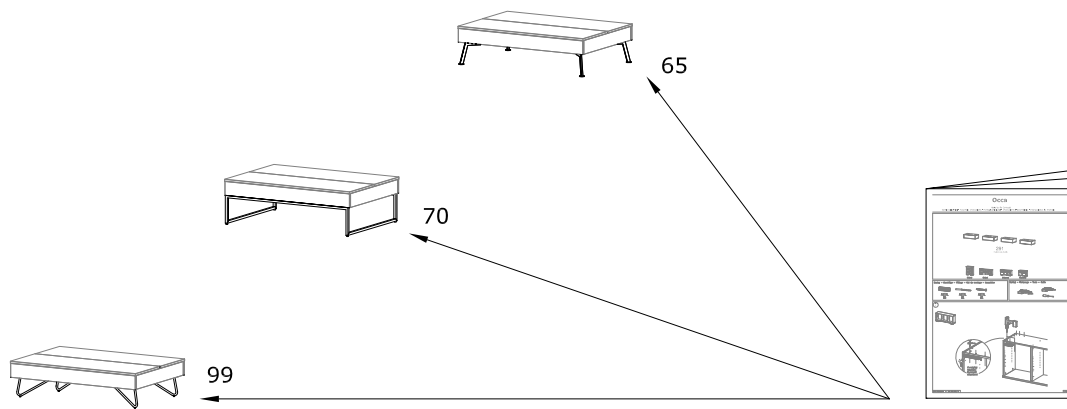

FIG. 7



Samlevejledning - Assembly Instructions - Montageanleitung - Instructions d'assemblage - Instrucciones de montaje

FIG. 8

x2

G X 8  
M5x16mm

H X 1  
3mm

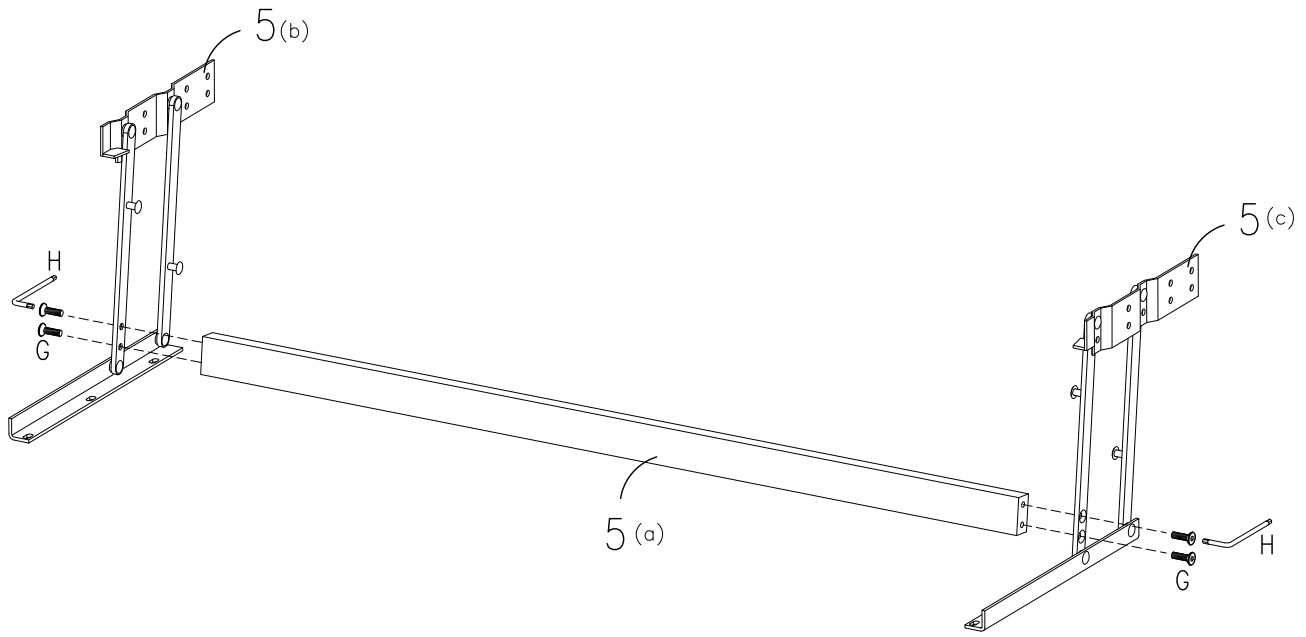

FIG. 9

J X 2

K X 2  
4,5x30mm

F X 12  
4,0x16mm

L X 12

step1

Attention!

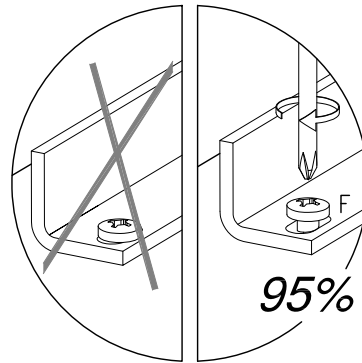
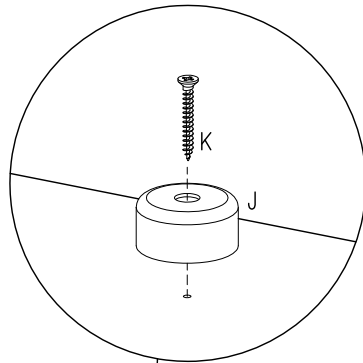

x2

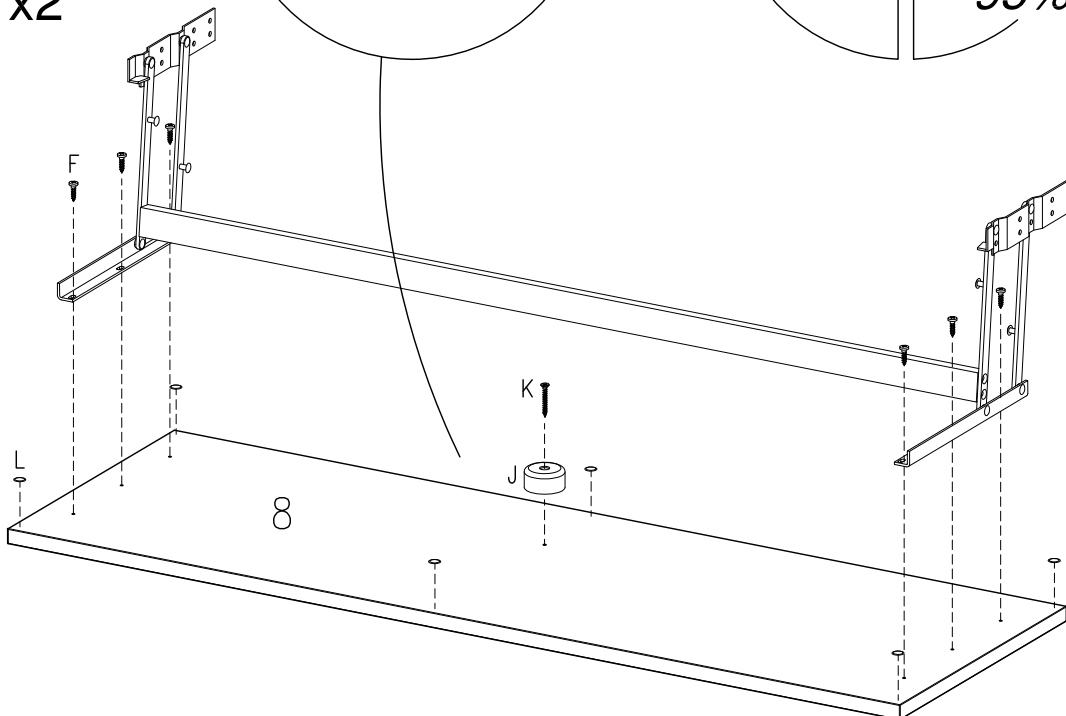
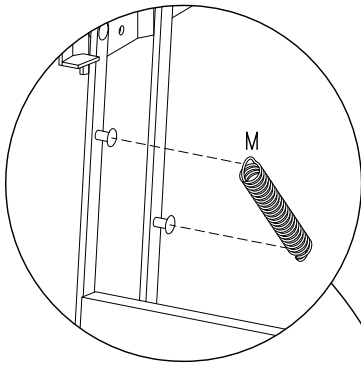

FIG. 10



Attention!

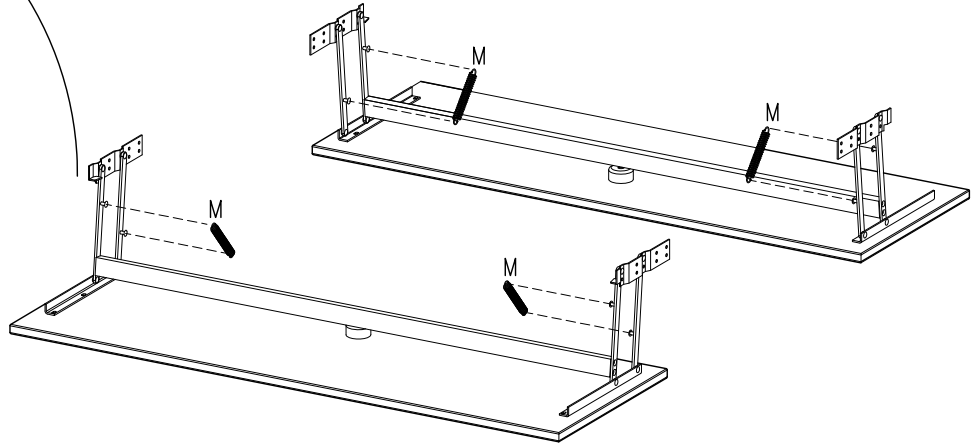
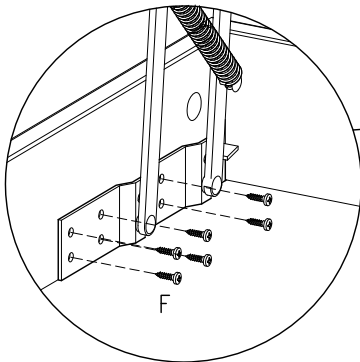
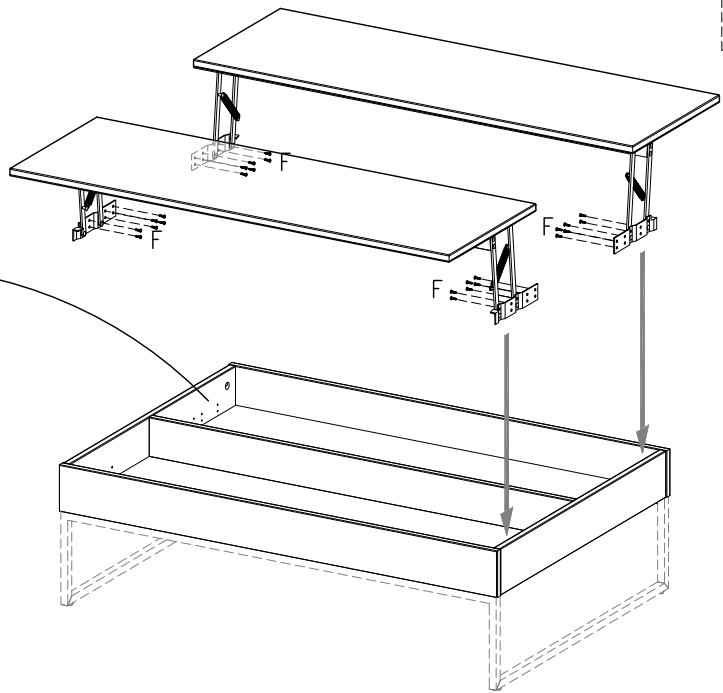

FIG. 11



F X 24  
4,0x16mm



Attention!

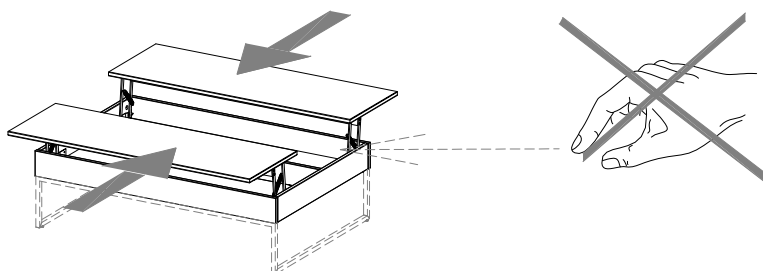

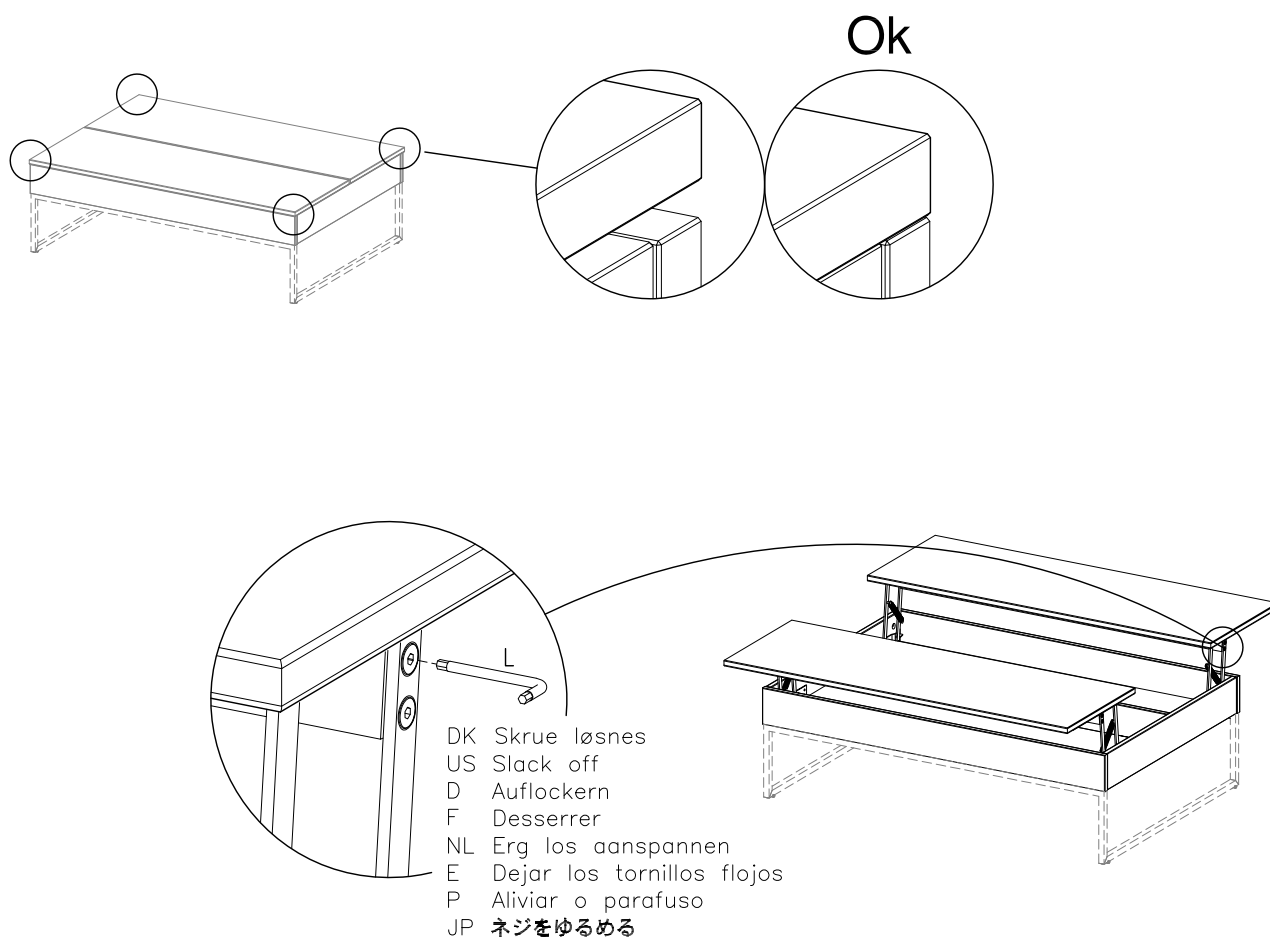
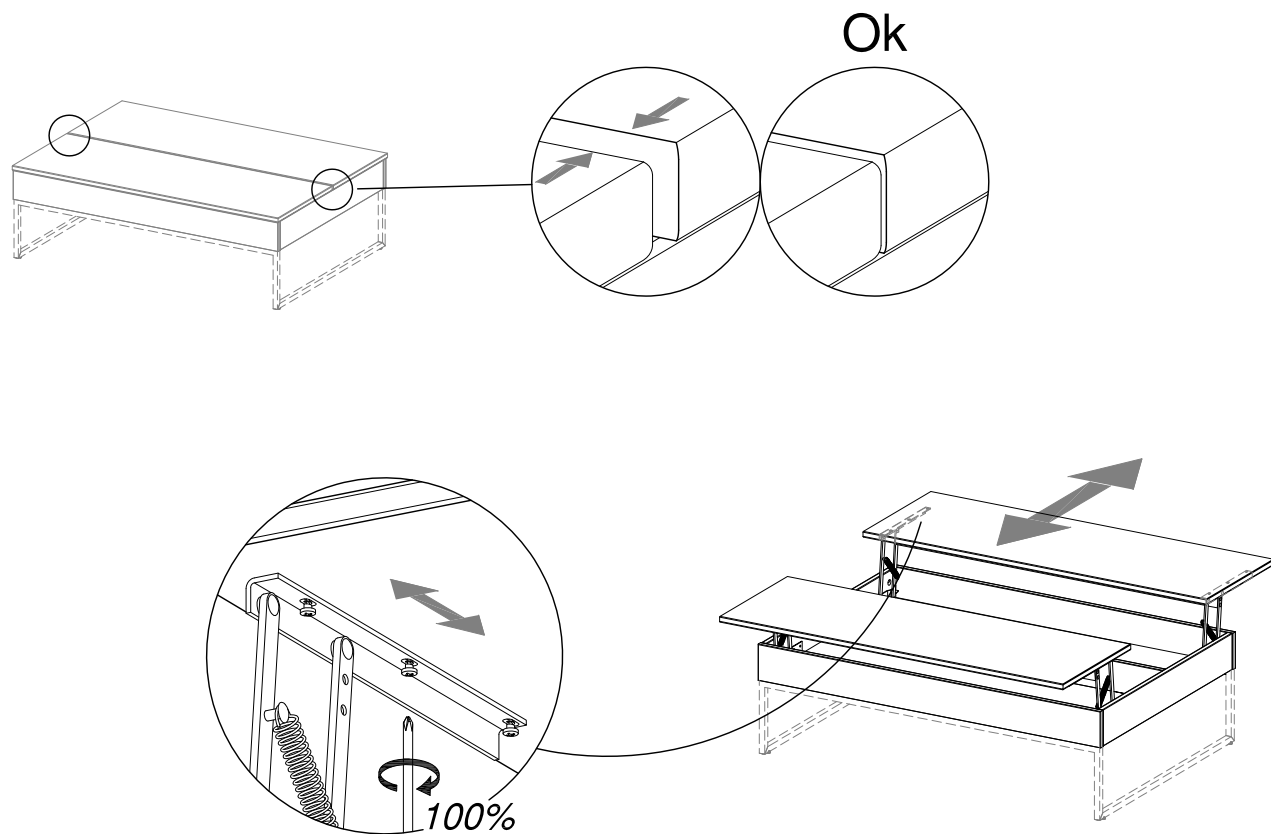

DK Kære BoConcept kunde!  
 Tillykke med dit nye BoConcept sofabord. Vi håber du bliver glad for det.  
 Til info beder vi dig læse nedenstående omhyggeligt inden produktet tages i brug:  
 Åbne-/lukkemekanismen er konstrueret efter sakseprincippet. Det betyder at der er potentiel risiko for klemmeskader mellem åbne-/lukkemekanismen og siderne.  
 Vi anbefaler, at der udvises agtpågivenhed når bordet foldes op og i, især når der er børn involveret.  
 Når disse forholdsregler er taget, er vi overbevist om, at du bliver glad for produktet.  
 Med venlig hilsen  
 BoConcept

US Dear BoConcept customer  
 Congratulations on your new BoConcept coffee table. We hope you will be pleased with it!  
 Just a few words of warning before you start using the product:  
 The open/close mechanism is constructed according to the scissors-principle. This means that there is a potential risk of jamming damage between the open/close mechanism and the sides.  
 We recommend extra caution when closing the tabletops, especially when children are involved.  
 With these few steps of caution we are confident that you will be happy with your new product.  
 Sincerely  
 BoConcept

D Lieber BoConcept Kunde  
 Herzlichen Glückwunsch zum neuen BoConcept Couchtisch. Wir hoffen, dass er Ihnen gefallen wird!  
 Einige Ermahnungswörter bevor Sie mit dem Gebrauch Ihres Tisches anfangen:  
 Die Öffnungs-/Schließvorrichtung ist nach dem Scherenprinzip konstruiert. Das heißt, dass es eine potentielle Risiko für Klemmschäden zwischen der Öffnungs-/Schließvorrichtung und den Seiten gibt.  
 Wir empfehlen, daß die Vorsicht erweisen, wenn Sie den Tisch zusammenfallen, besonders mit Kindern anwesend.  
 Mit diesen Maßnahmen in Erinnerung, sind wir davon überzeugt, das Ihnen Ihr neues Produkt sehr gefallen wird.  
 Mit freundlichen Grüßen  
 BoConcept

F Cher Client BoConcept  
 Toutes nos félicitations pour l'achat de votre nouvelle table basse Boconcept. Nous espérons qu'elle vous apportera entière satisfaction.  
 Quelques mots de précautions toutefois avant la première utilisation de votre table.  
 Le mécanisme d'ouverture et de fermeture est un système en ciseaux. Ce qui veut dire qu'il y a un risque potentiel d'accidents de coinçage entre le mécanisme d'ouverture et les côtés.  
 Nous vous recommandons de faire particulièrement attention au moment de la fermeture des plateaux, surtout s'il y a des enfants à proximité.  
 Avec ces quelques petites précautions d'emploi, nous sommes certains que vous serez entièrement satisfait de votre nouvelle acquisition.  
 sincèrement  
 BoConcept

E Estimado cliente de BoConcept  
 Enhorabuena en su nueva mesa de centro de BoConcept. ¡Esperamos que usted esté satisfecho con ella!  
 Apenas algunas palabras del cuidado antes de usted comience a usar el producto:  
 El mecanismo abierto/cercano se construye según el tijera-principio. Esto significa que hay un riesgo potencial de daño de atasco entre el mecanismo abierto/cercano y los lados. Recomendamos la precaución adicional al cerrar los tableros de la mesa, especialmente cuando los niños están implicados.  
 Con estos pocos pasos de la precaución nos sentimos confiados que usted será feliz con su nuevo producto.  
 Sinceramente  
 BoConcept

NL Beste Boconcept klant,  
 Gefeliciteerd met uw Boconcept tafel. We hopen dat u er veel plezier mee zult hebben.  
 Even een paar woorden ter attentie, voordat u het bed gaat gebruiken:  
 Het open/sluitings meganisme is gekonstrueerd volgens het schaar principe. Hiermee bedoelen we dat er een risico is dat er iets geklemd kan worden tussen het open/sluitings meganisme en de kanten.  
 We aanbevelen daarom extra voorzichtig te zijn als de tafel uitgevouwen wordt, special als er kinderen bij betrokken zijn.  
 Met deze kleine tips ter attentie, vertrouwen wij er op, dat u blij zult zijn met uw nieuwe product  
 Met vriendelijke groeten,  
 BoConcept

P Caro Cliente BoConcept  
 Parabéns pela sua nova mesa de café BoConcept. Esperamos que fique satisfeito com ela!  
 Gostaríamos apenas de lhe dar algumas palavras de aviso antes de começar a usar o produto: O mecanismo de abertura/fecho foi construído de acordo com o princípio da tesoura. Isto significa que existe um risco potencial de lesões por encravamento entre o mecanismo de abertura/fecho e os lados. Recomendamos que tenha cuidado ao dobrar os tampos, especialmente nas situações em que estejam crianças envolvidas.  
 Com estes passos de precaução, temos a certeza que ficará contente com o seu novo produto.  
 Atenciosamente  
 BoConcept

J お客様各位  
 この度は、**BoConcept**のコーヒーテーブルをお買い求めいただき、ありがとうございます。ご利用の皆様にも、十分ご満足いただけることを願っております。  
 なお、この製品をご利用になる前に、以下の点についてご留意ください。開閉のメカニズムは、ハサミの原理に基づいています。したがって、この開閉のメカニズムとサイド部分との間に、指や物を挟んでしまう可能性があり、危険です。テーブルトップを収納する際、特にお子様が傍にいらっしゃる際には、十分ご注意ください。  
 それでは、以上の点にのみご留意の上、この製品を十分にお楽しみください。  
**BoConcept** スタッフ一同

DK Ved reklamation oplyses følgende:  
 D Im Reklamationsfall, bitte folgendes erläutern:  
 US In case of claims, please state the following:  
 F En cas de réclamation, veuillez indiquer:  
 NL Bij service volgene mededelen  
 E En caso de reclamación, indicar lo siguiente:  
 P No caso de reclamação, por favor indique o seguinte:  
 JP お気づきの点等ございましたら、以下の点をお知らせください。

Example!

