

# Wardrobe Concept - BASE

Design by BoConcept

Samvejledning - Assembly Instructions - Montageanleitung - Instructions d'assemblage - Instrucciones de montaje

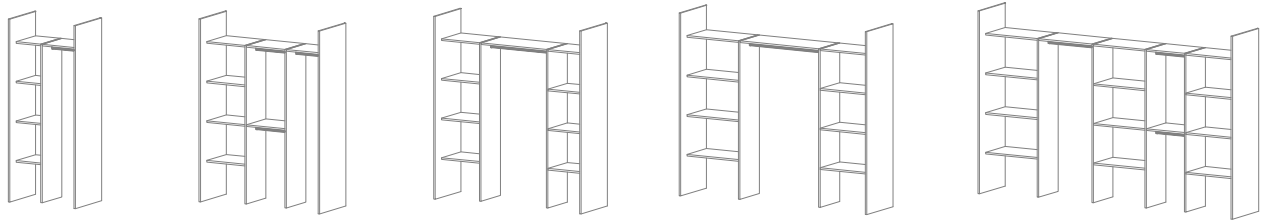

## Example

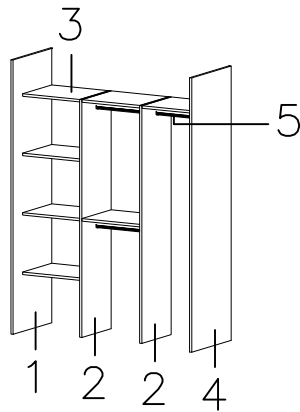

Step 1

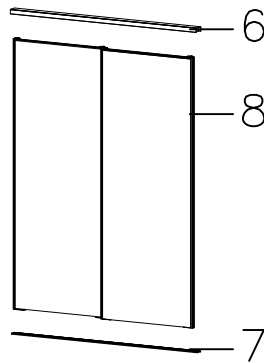

Step 2

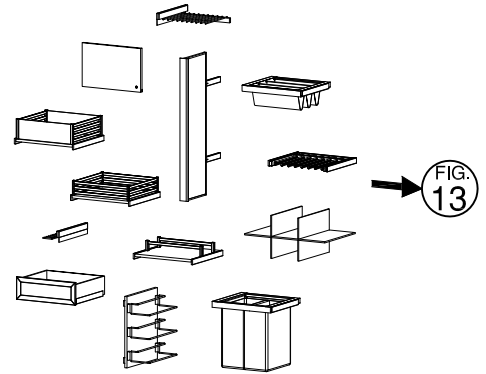

Step 3

FIG. 13

### Korpus - Korpus - Carcase - Carcasse



A  
U8-400



B  
U5-024  
4,2x10,5mm



C  
U2-009



D  
U2-011  
3,5x16mm



E  
U8-003

### Rail



F  
U4-026  
3,9x19mm



G  
U9-013  
5m

### Door

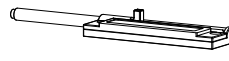

H(1)  
U3-105



H(2)  
U3-106



H(3)  
U3-106



F  
U4-026  
3,9x19mm



J  
U4-051  
2,9x16mm



K  
U2-027

### Drawers, door and pull-outs



B  
U5-024  
4,2x10,5mm



D  
U2-011  
3,5x16mm



L  
U3-005



LL  
U9-202



M  
U3-002  
left



N  
U3-003  
right



P  
U5-068  
3,0x16mm



Q  
U4-011  
4,0x25mm



R  
3,5x30mm  
1978003530



S  
U3-024



T  
U3-025



U  
U9-912



V  
U9-911



W  
1978103535  
3,5x35mm

### Værktøj - Werkzeuge - Tools - Outils

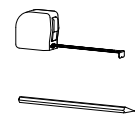
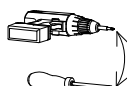
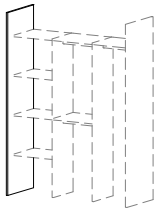

FIG. 1



Example

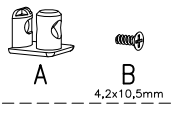
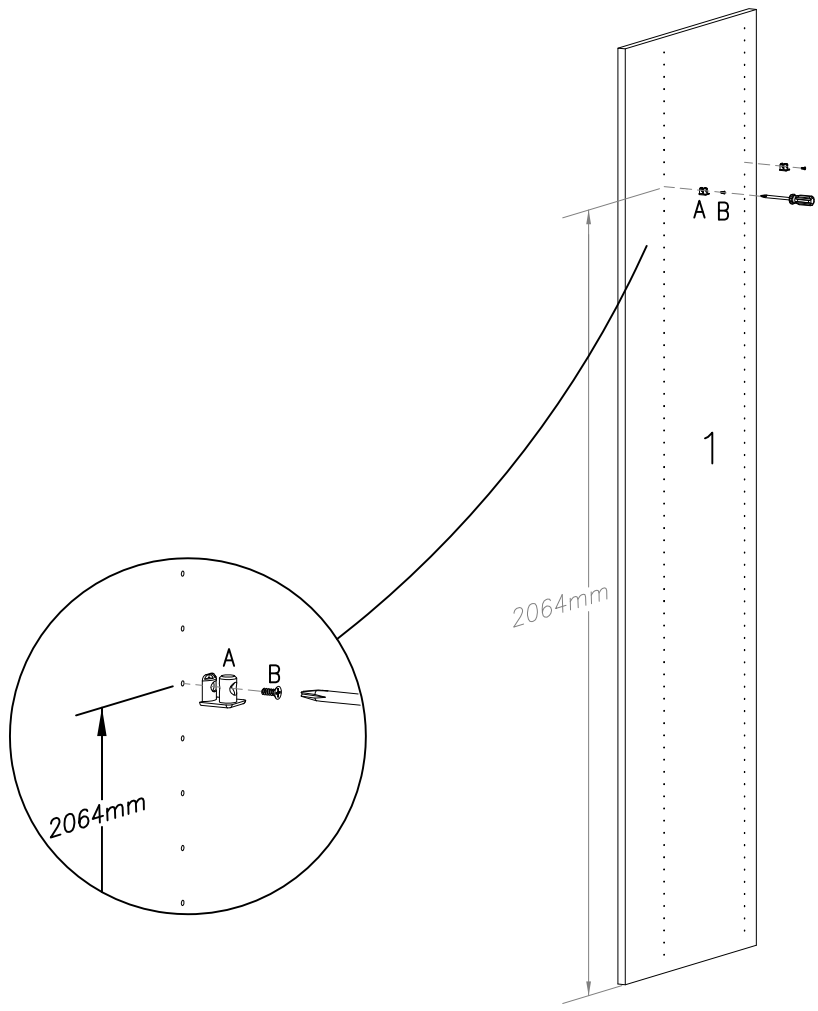
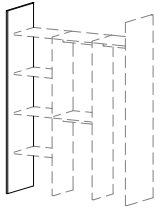
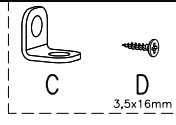
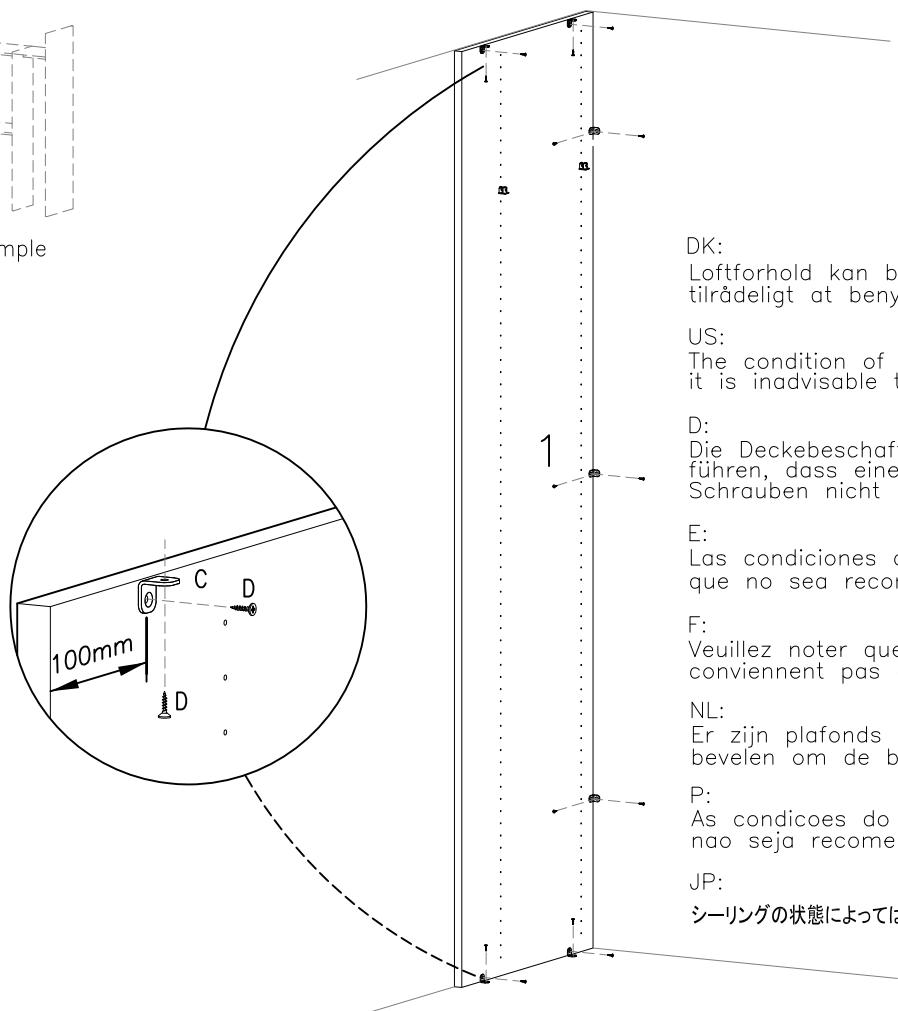

FIG. 2



Example



DK:  
Løftforhold kan bevirke, at det ikke er tilrådeligt at benytte de medfølgende skruer.

US:  
The condition of the ceiling may mean that it is inadvisable to use the enclosed screws.

D:  
Die Deckebeschaffenheit kann ggf. dazu führen, dass eine Verwendung der beigefügten Schrauben nicht ratsam ist.

E:  
Las condiciones del techo pueden hacer que no sea recomendable utilizar tornillos

F:  
Veuillez noter que les vis jointes ne conviennent pas à tous les types de plafond.

NL:  
Er zijn plafonds waarin het niet valt aan te bevelen om de bijgevoegde schroeven te gebruiken.

P:  
As condicoes do tecto Podem dar Lugar a que nao seja recomendavel o USO de parafusos

JP:  
シーリングの状態によっては、製品付属のネジの使用は避けた方がよい場合があります。

FIG. 3

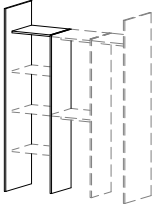

Example

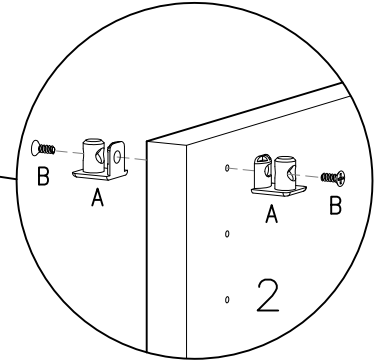
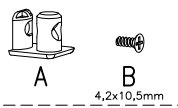
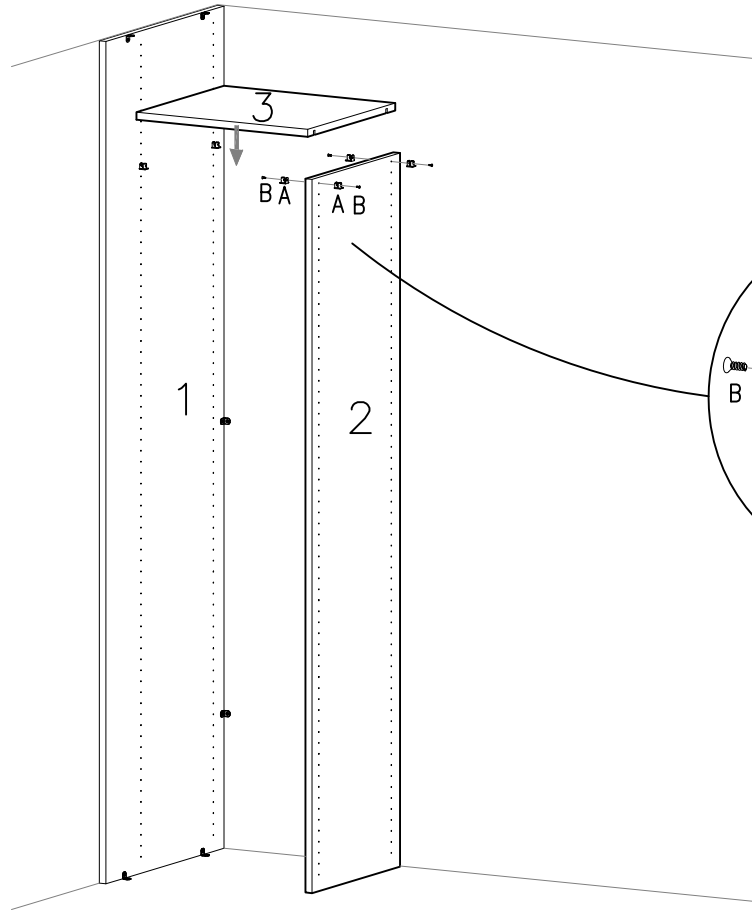
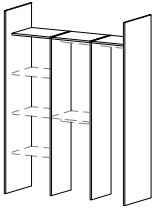

FIG. 4



Example

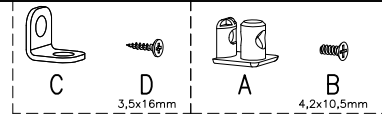
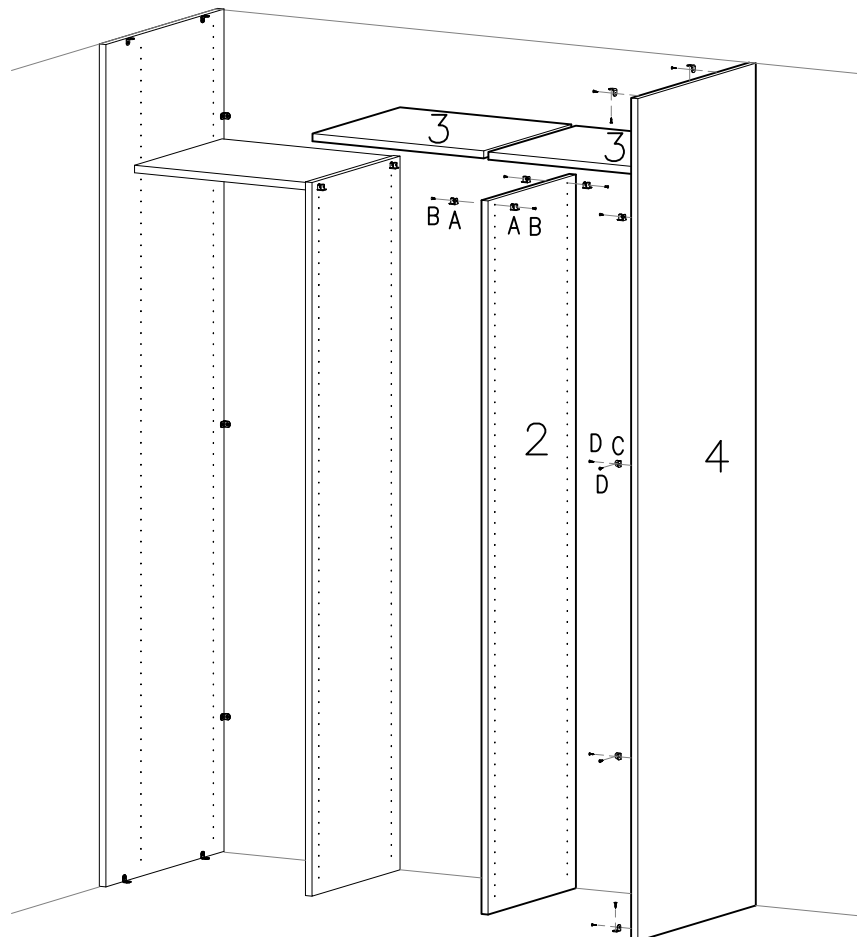
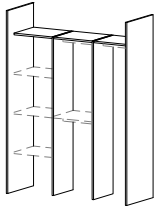

FIG. 5



Example

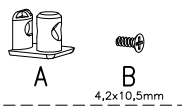
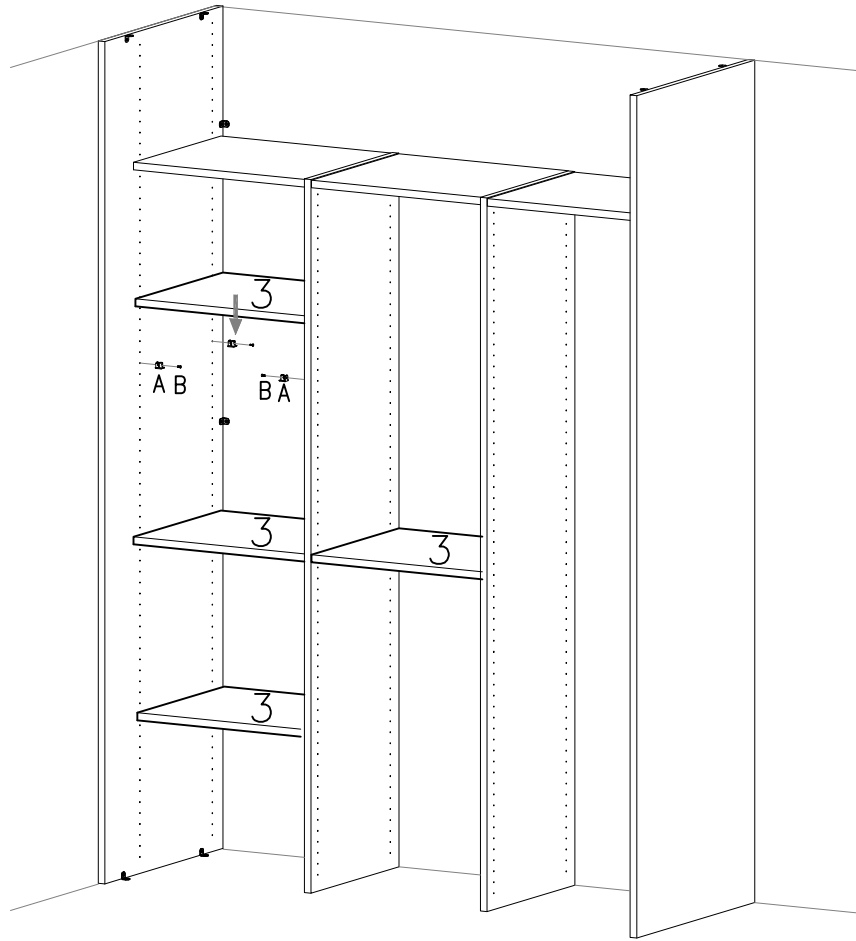
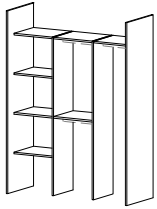

FIG. 6



Example

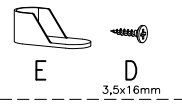
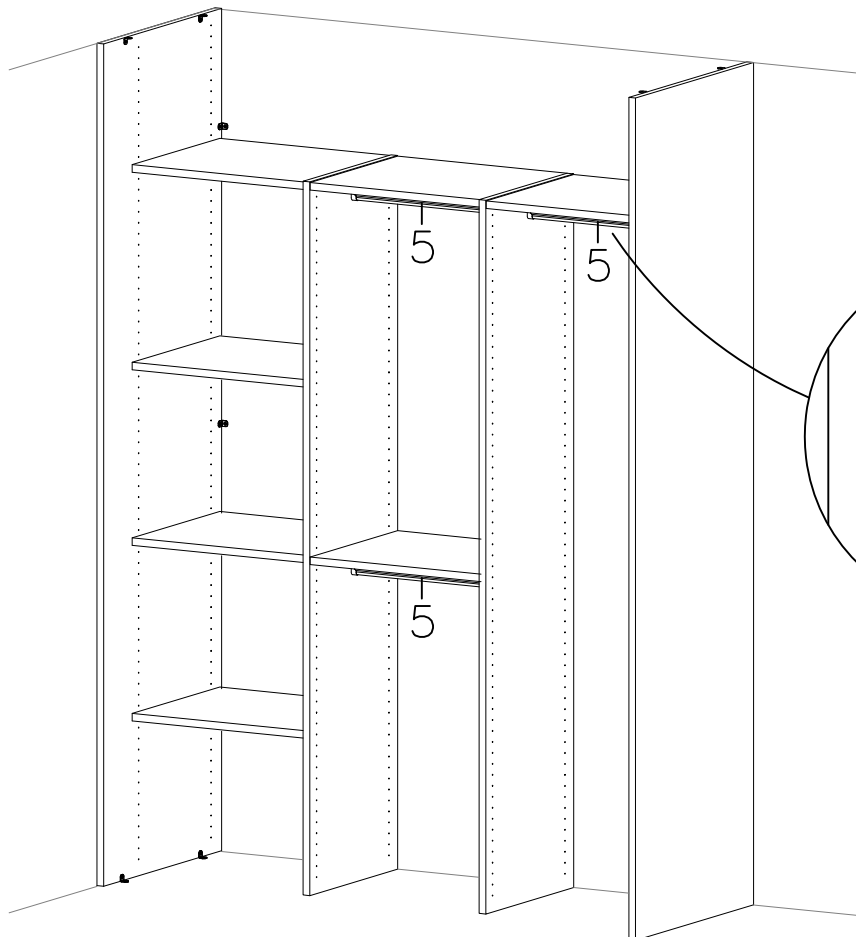

FIG. 7

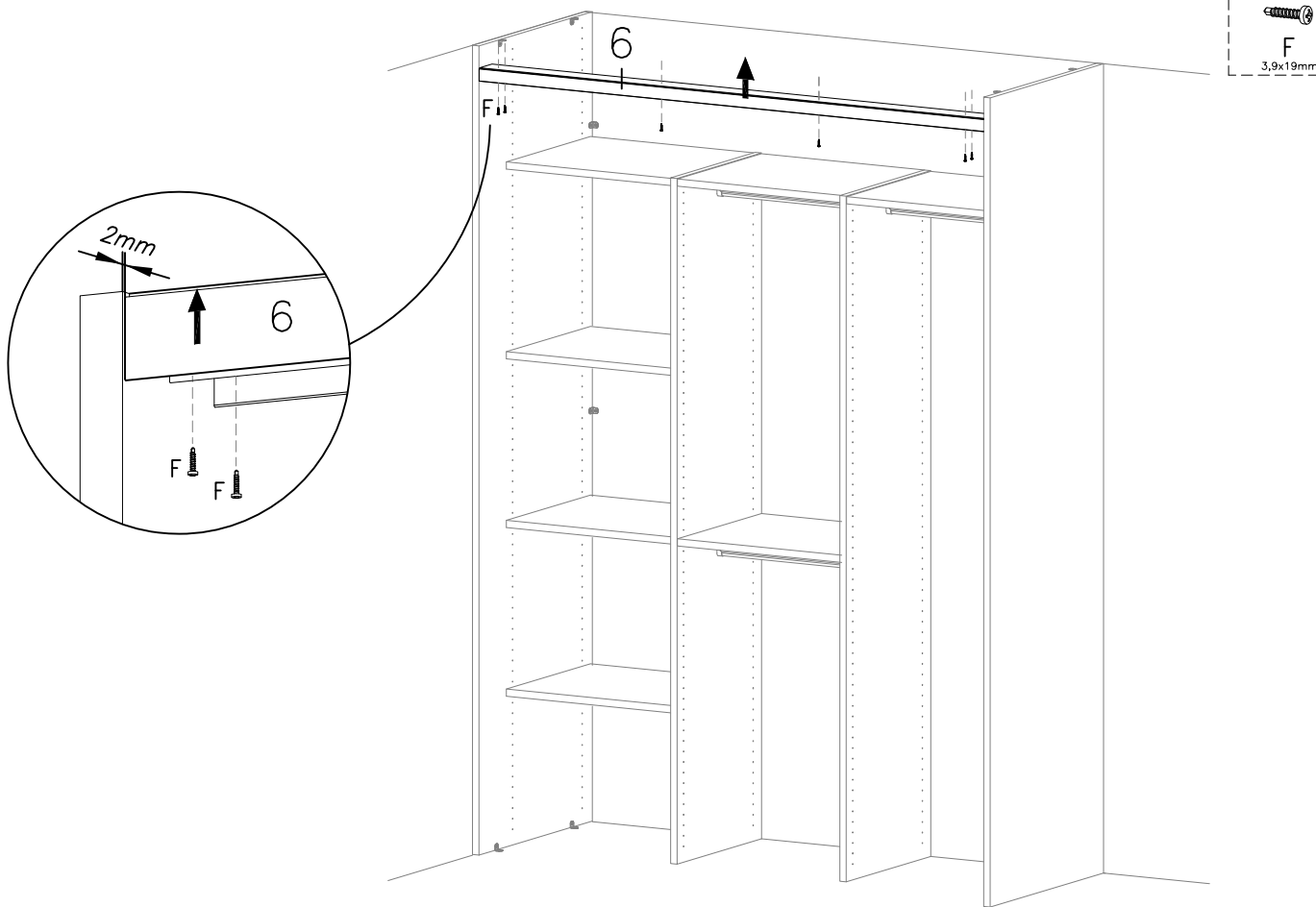

FIG. 8

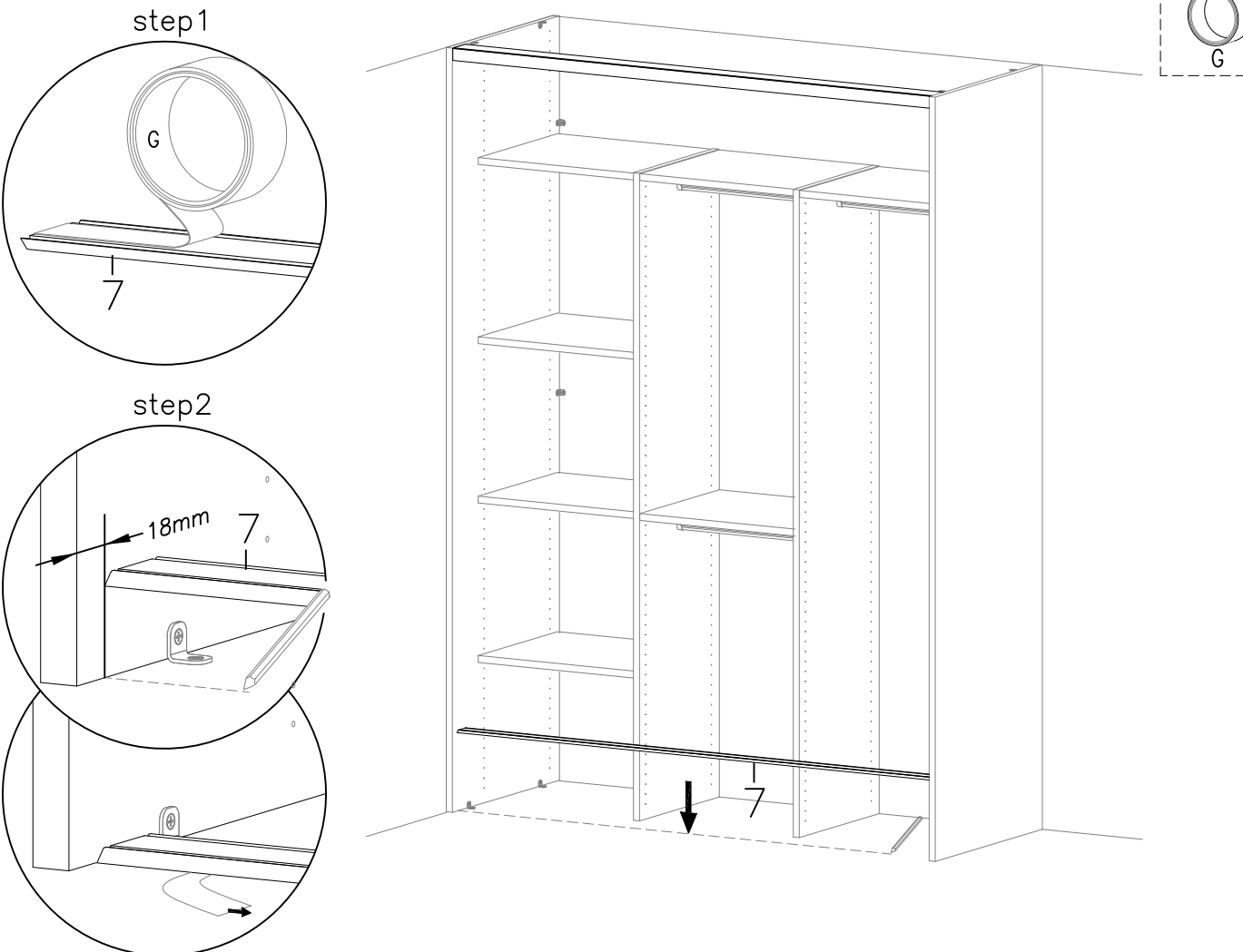
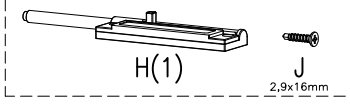
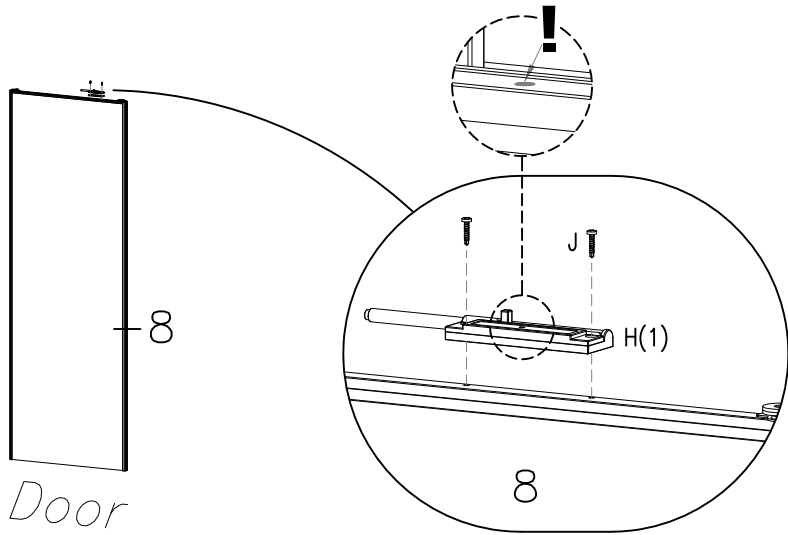

FIG. 9



Softclose

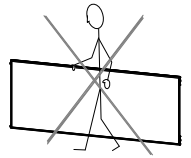
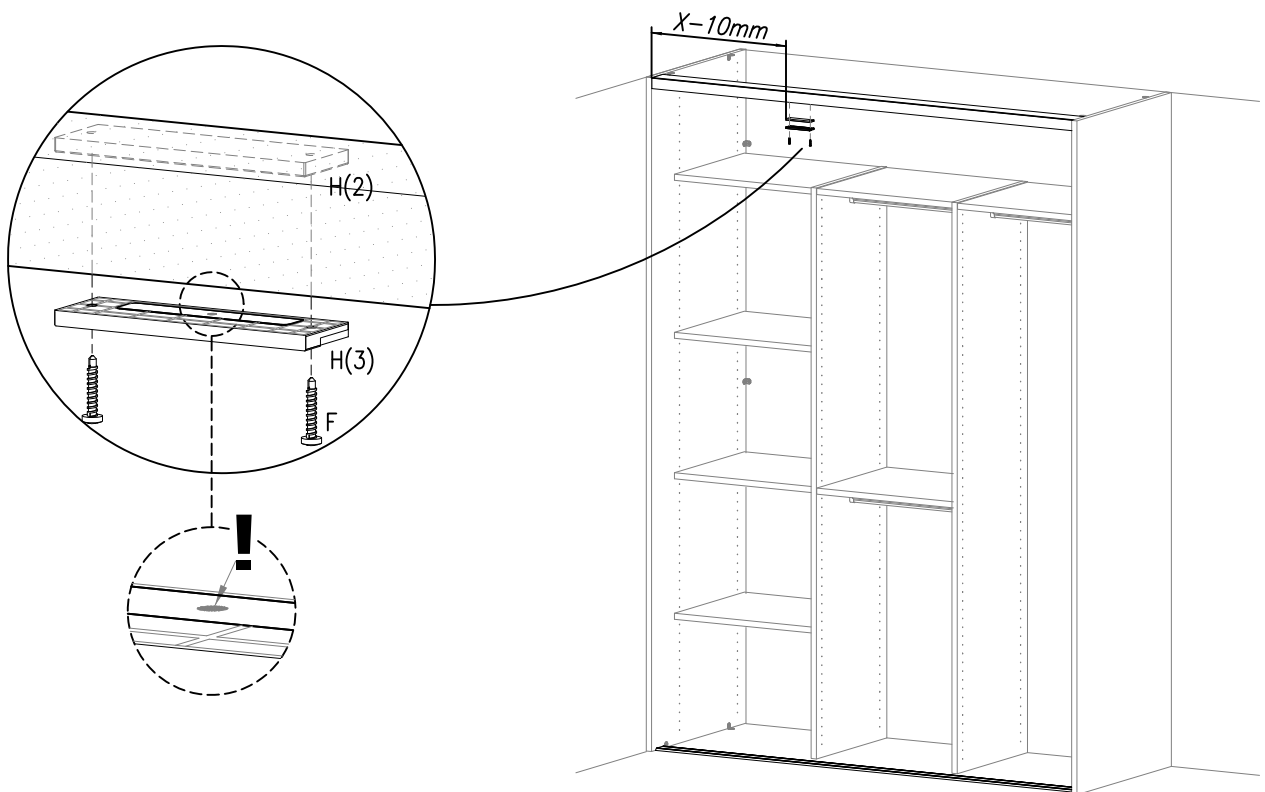
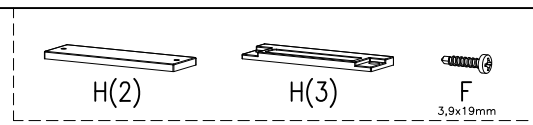
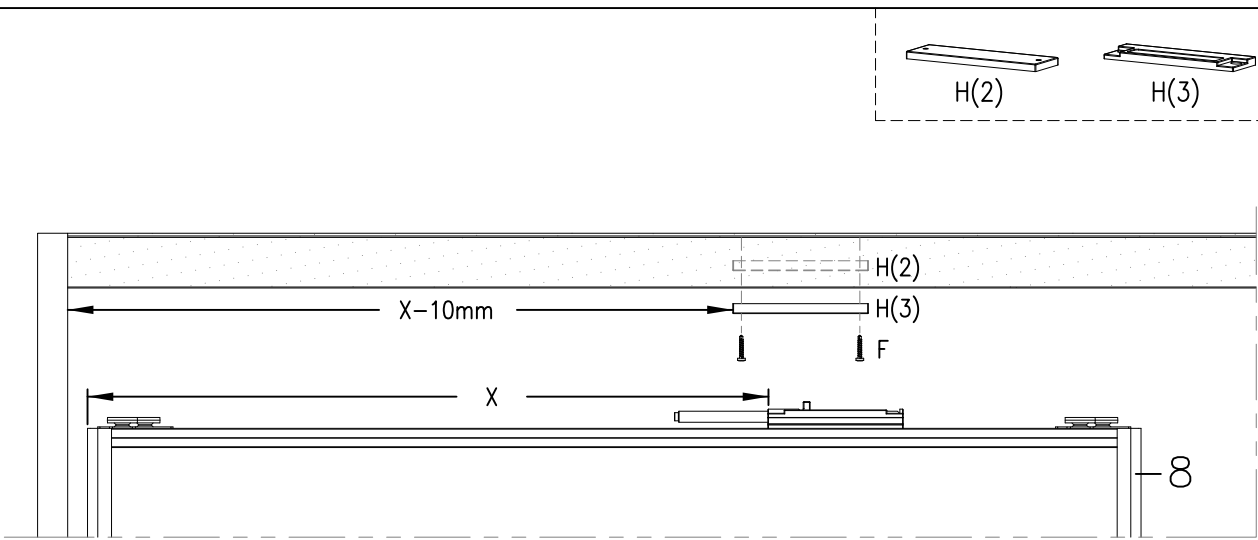

FIG. 10



Appropriate door placement - 3 doors



Appropriate door placement - 4 doors

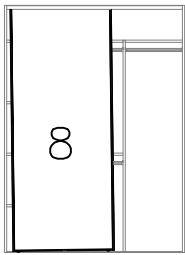
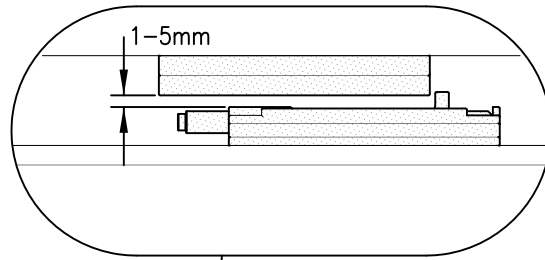
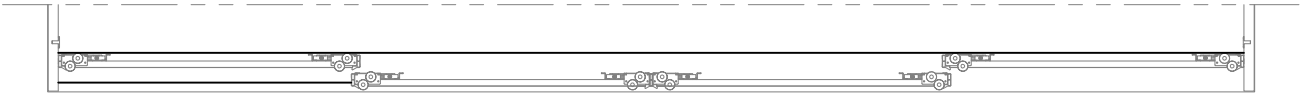

Justering - Justierung  
 Adjusting - Réglage  
 Bijstelling - Ajuste  
 Regolazione - Ajustação

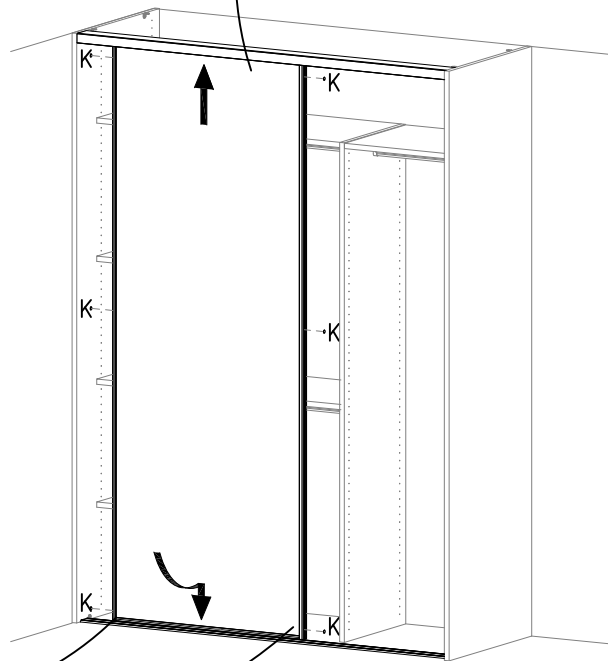
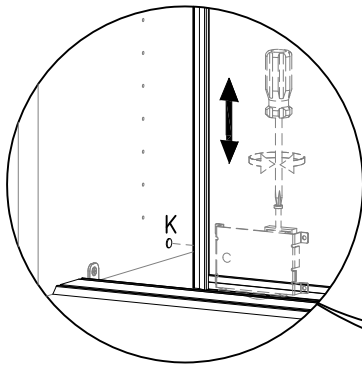

FIG. 13

5500/5510/5520    5700/5710/5720    5600/5610

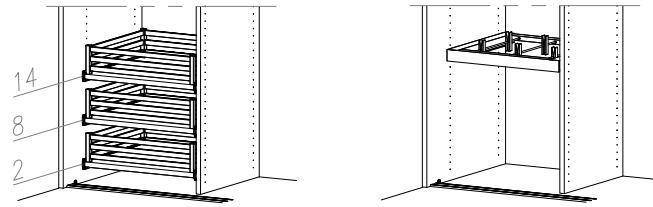



FIG. 14

 L  
U3-005

 B  
U5-024  
4,2x10,5mm

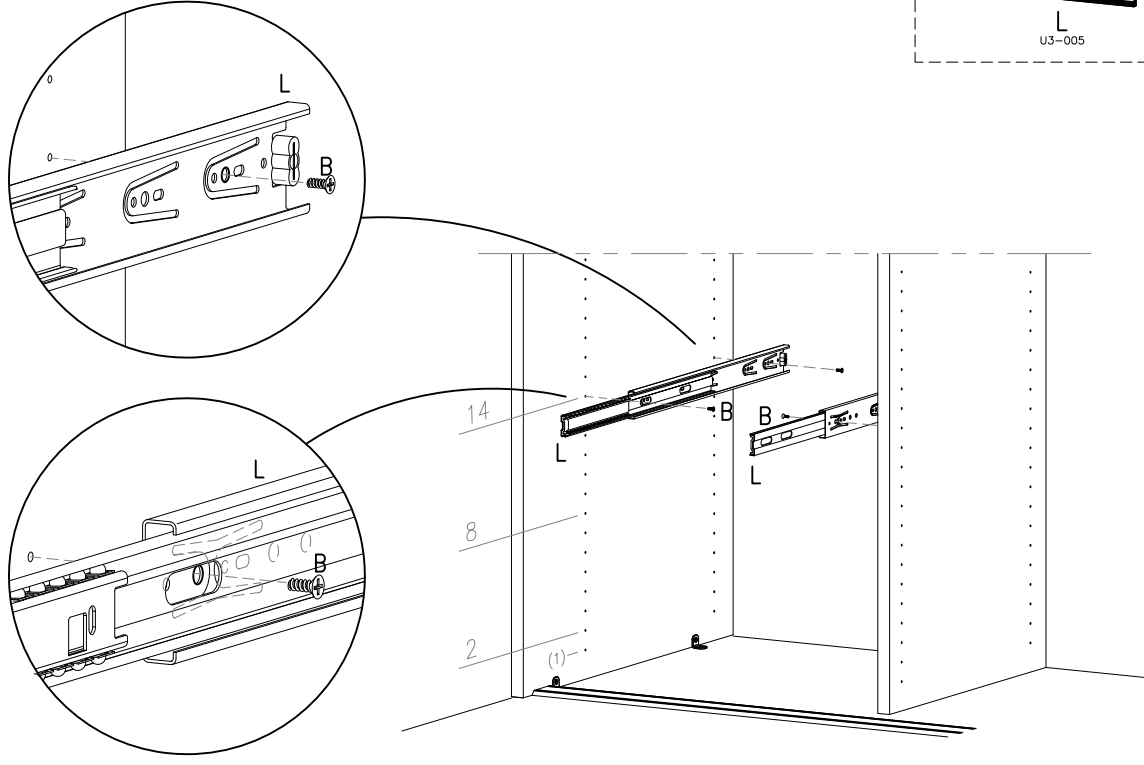

FIG. 15

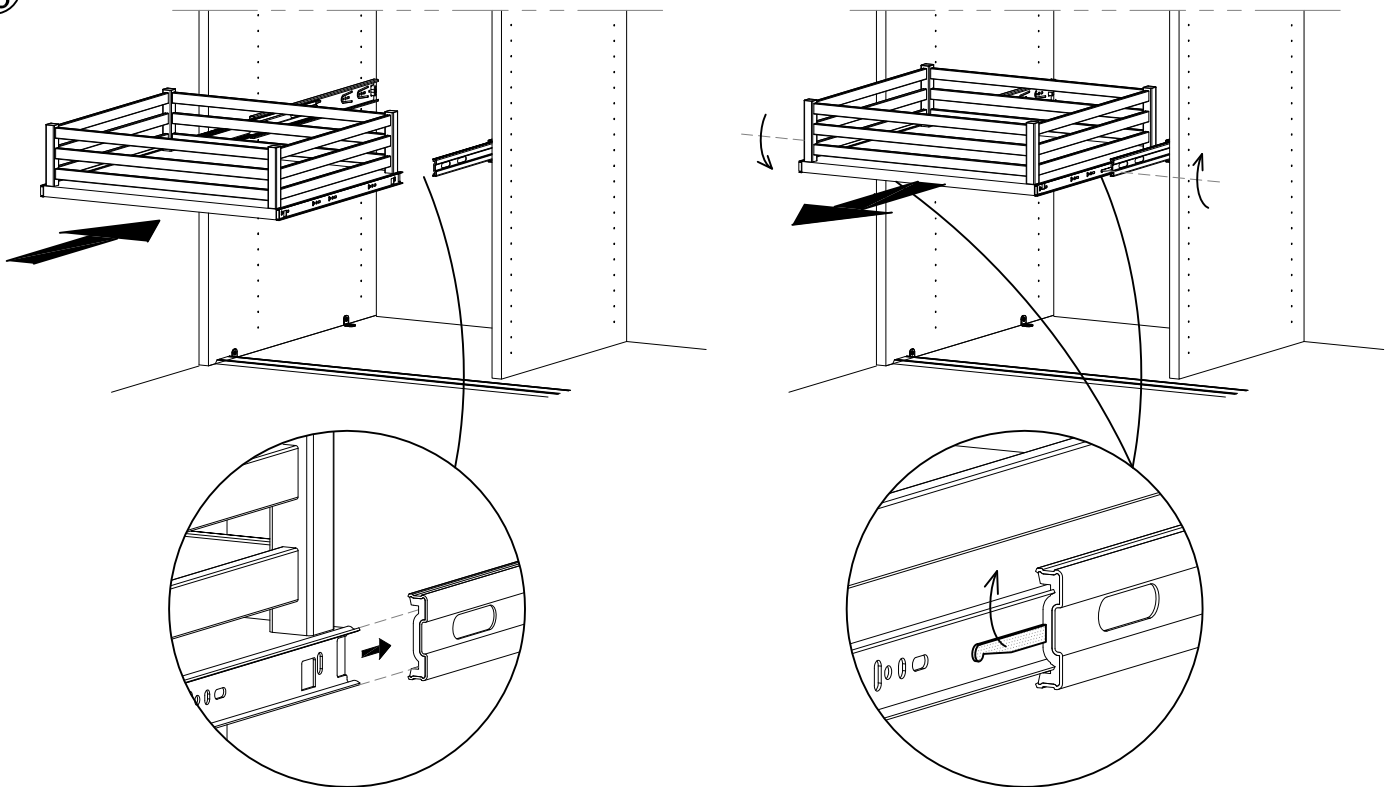



FIG. 16

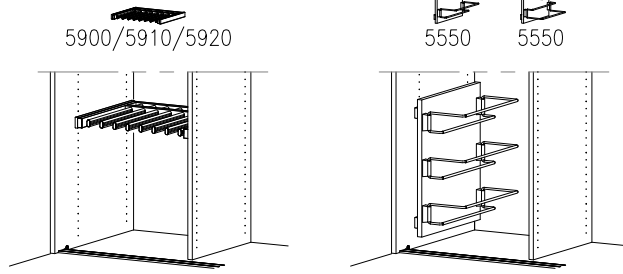

FIG. 17

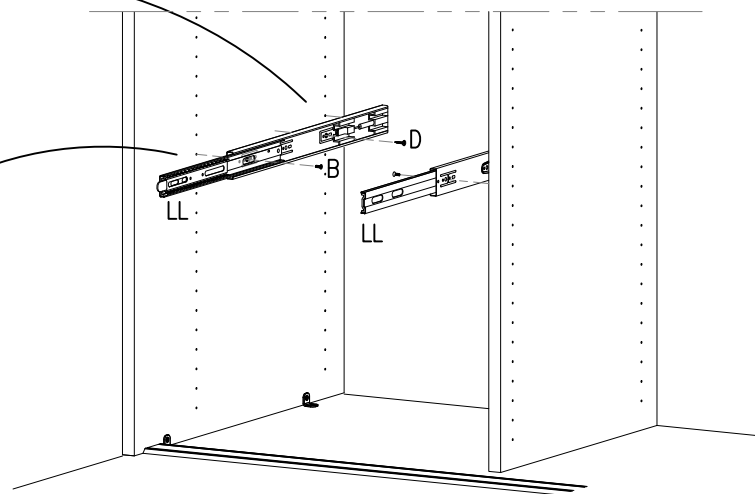
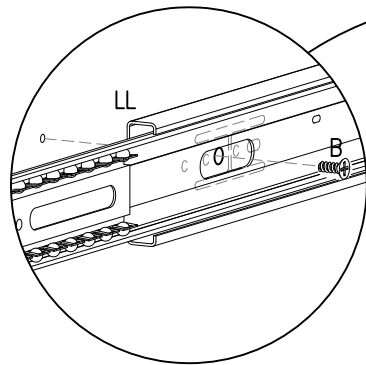
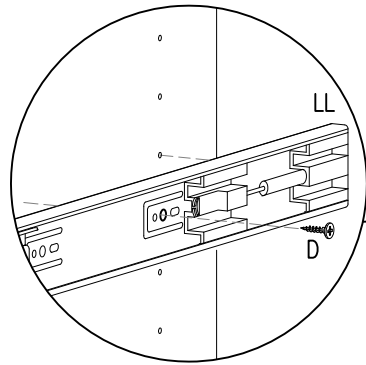

FIG. 18

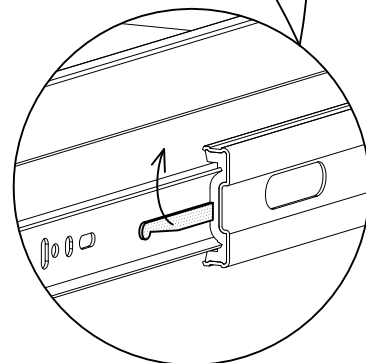
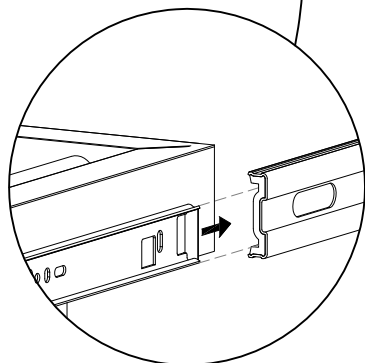
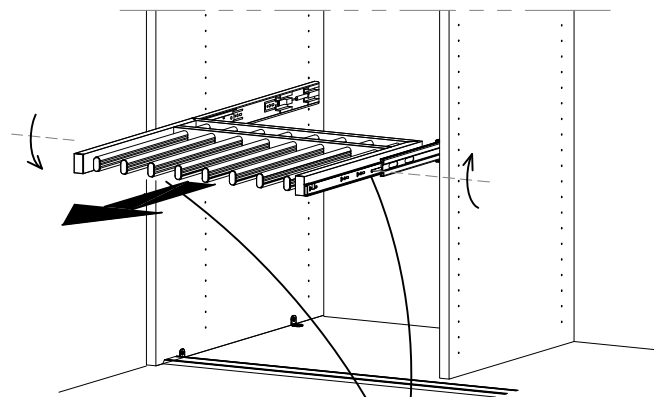
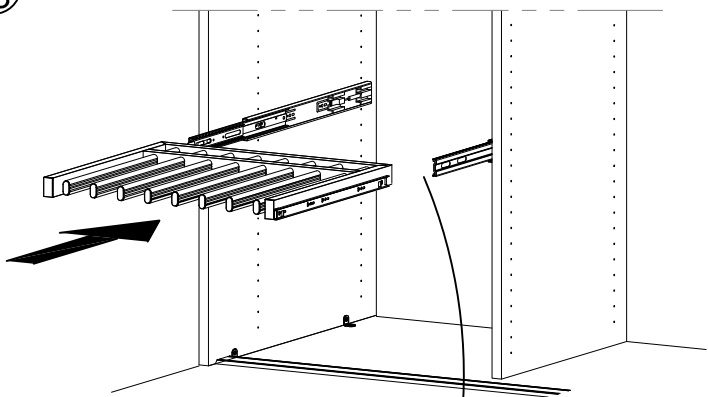

FIG. 19

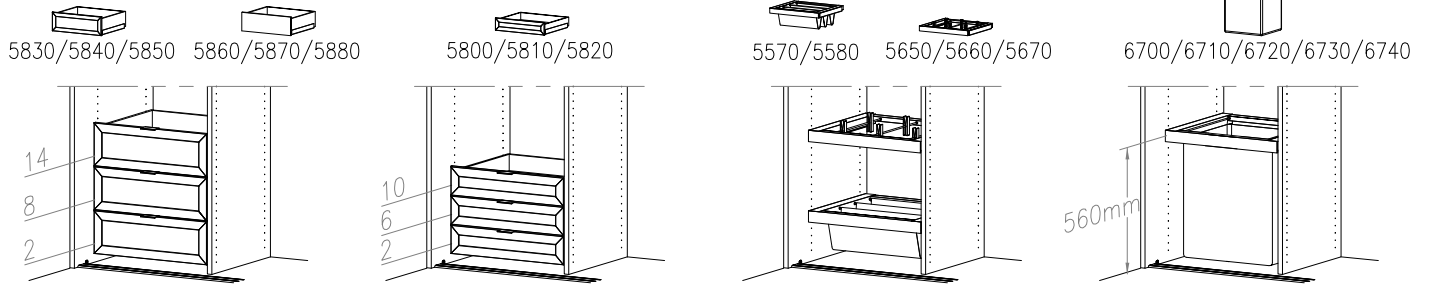

FIG. 20

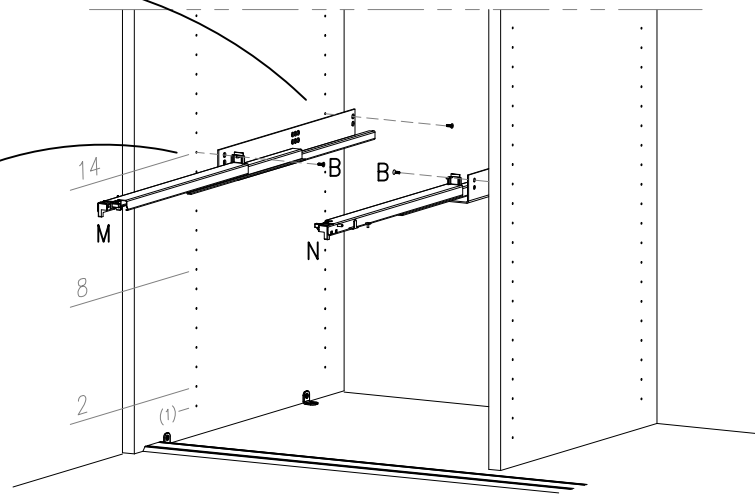
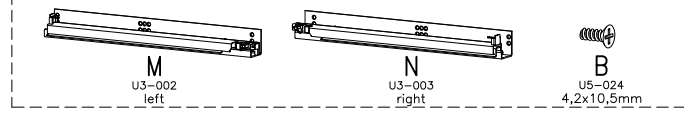
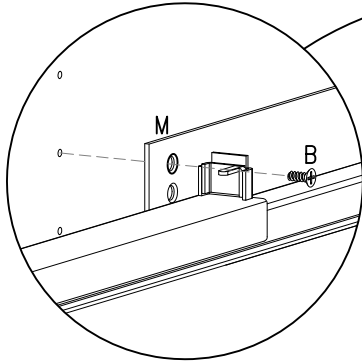
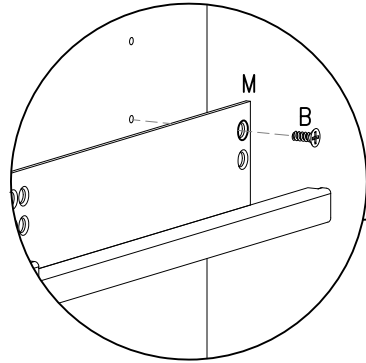
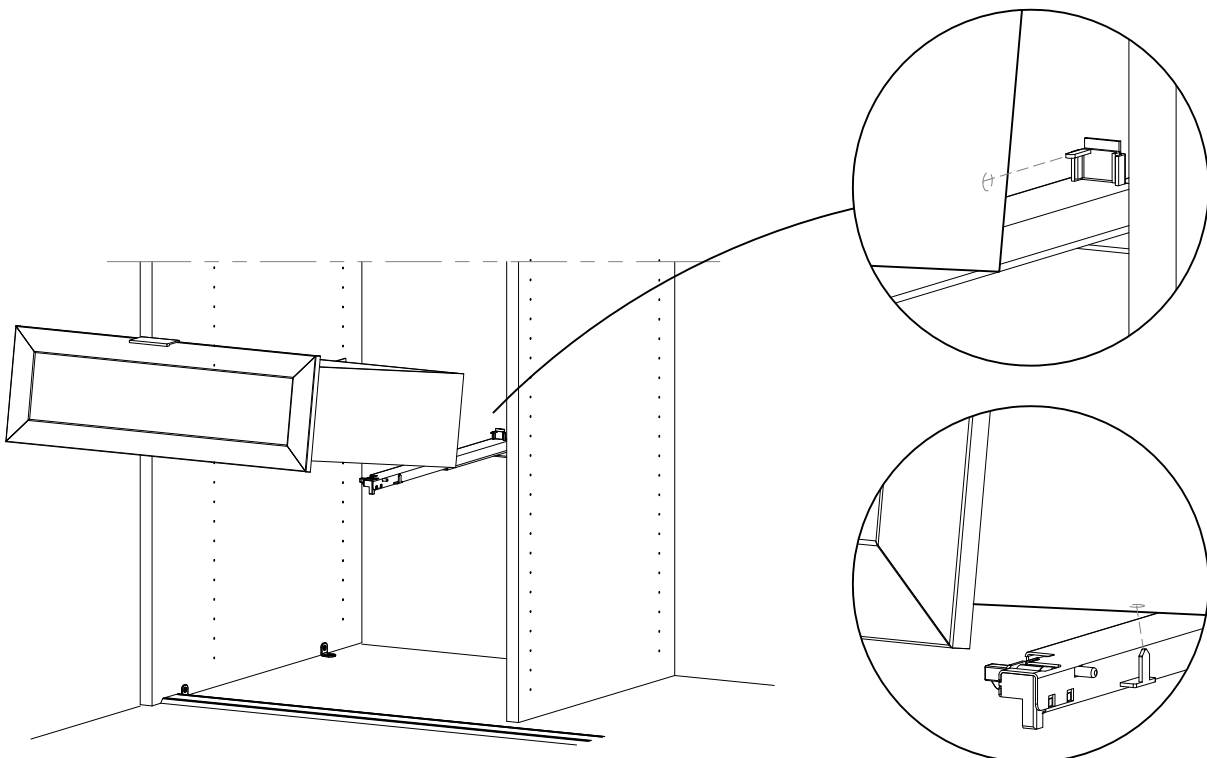

FIG. 21



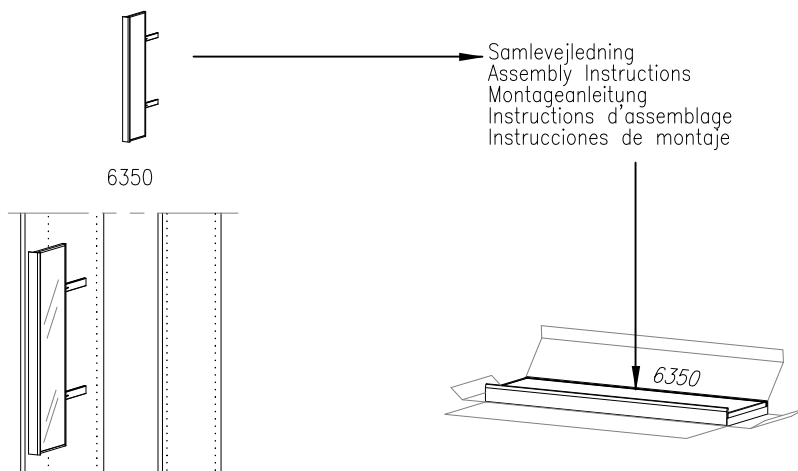
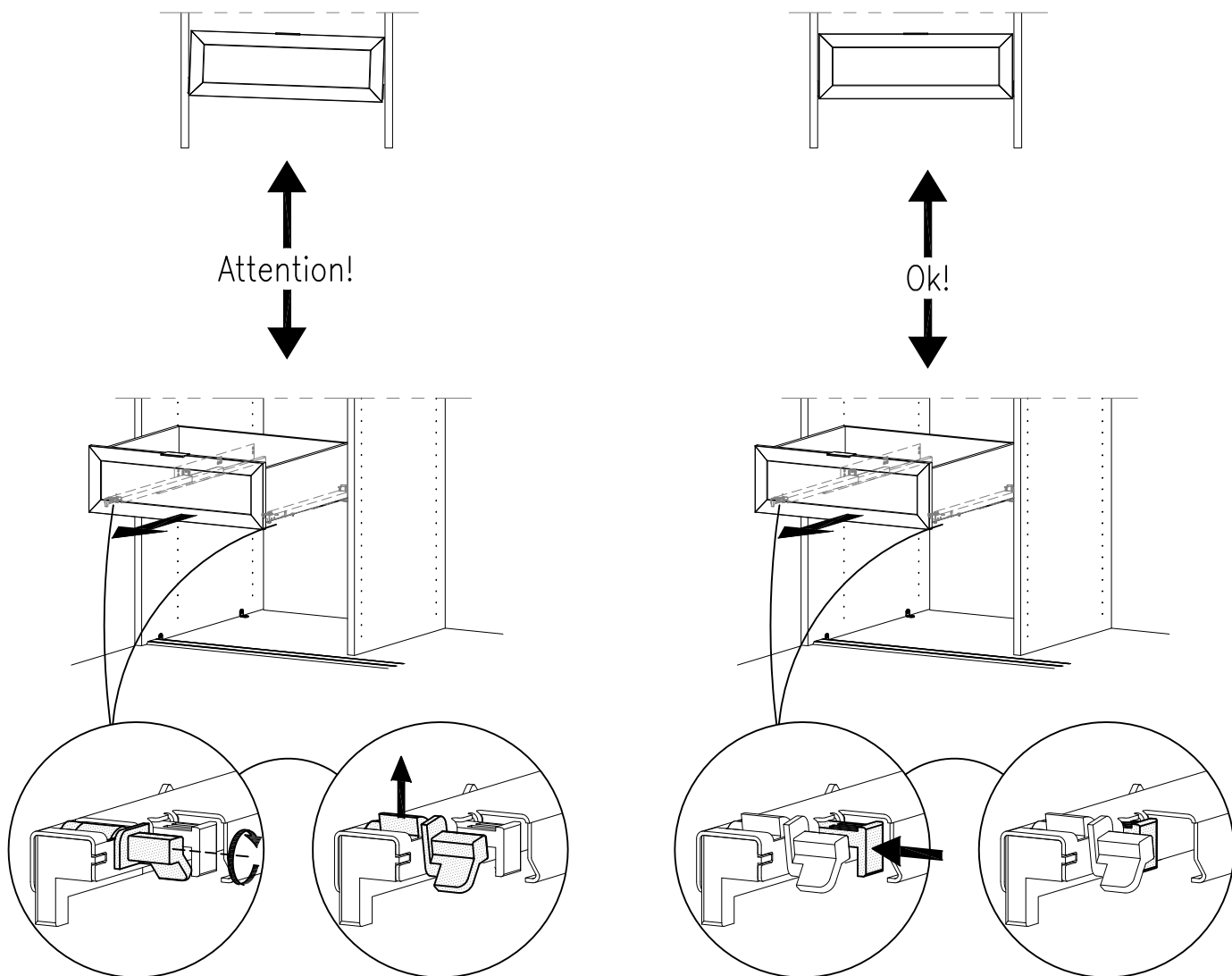
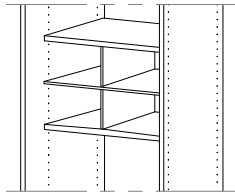
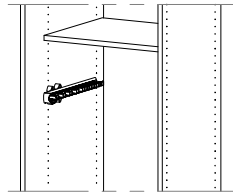

FIG. 23

5950/5960



6310/6320



6200

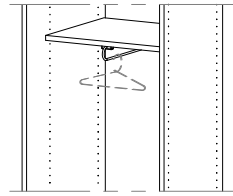

FIG. 24

P  
U5-068  
3,0x16mm

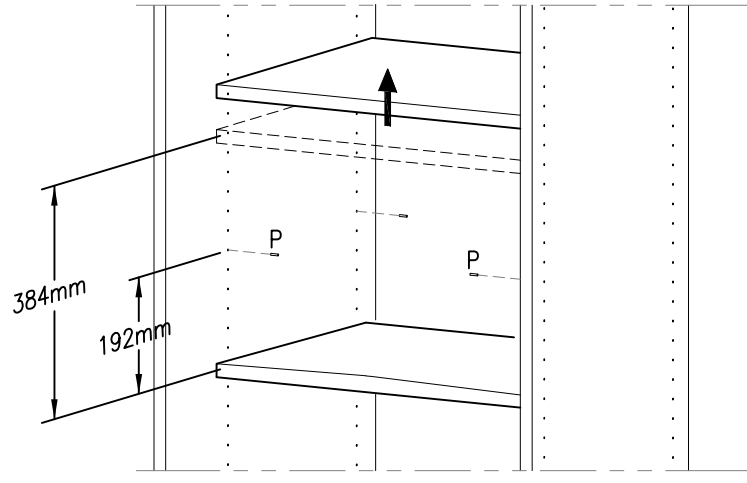
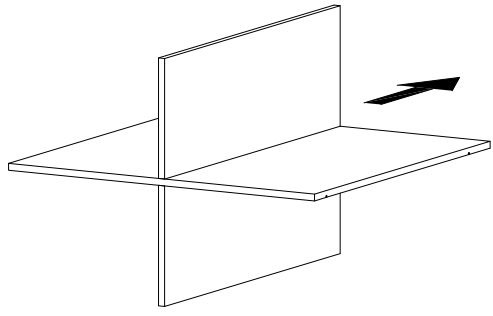

FIG. 25

Q  
U4-011  
4,0x25mm

R  
3,5x30mm  
1978003530

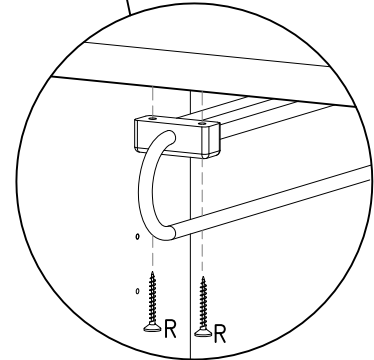
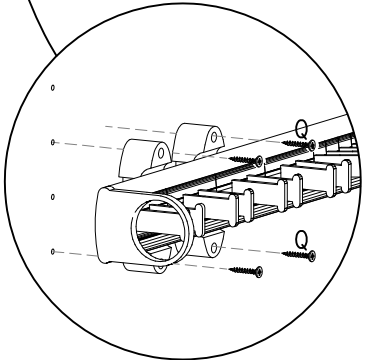
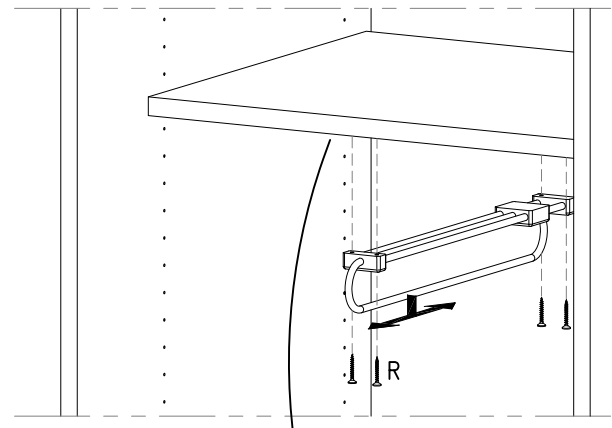
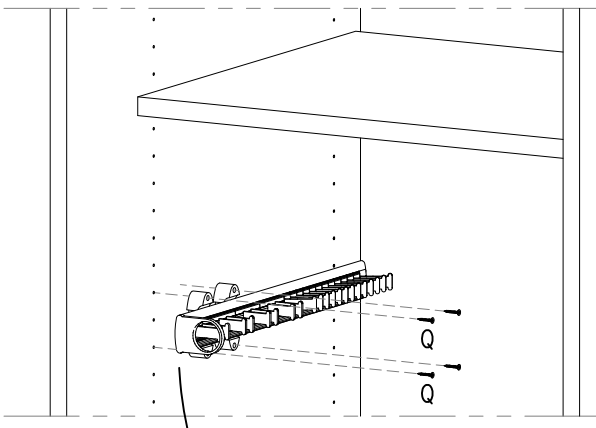

FIG. 26

6000/6010/6020

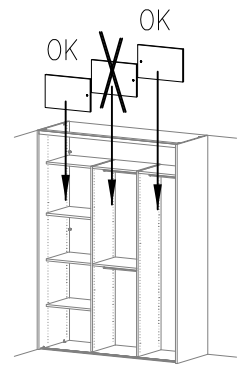
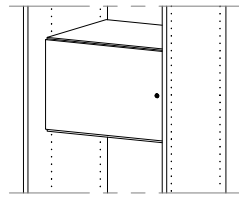
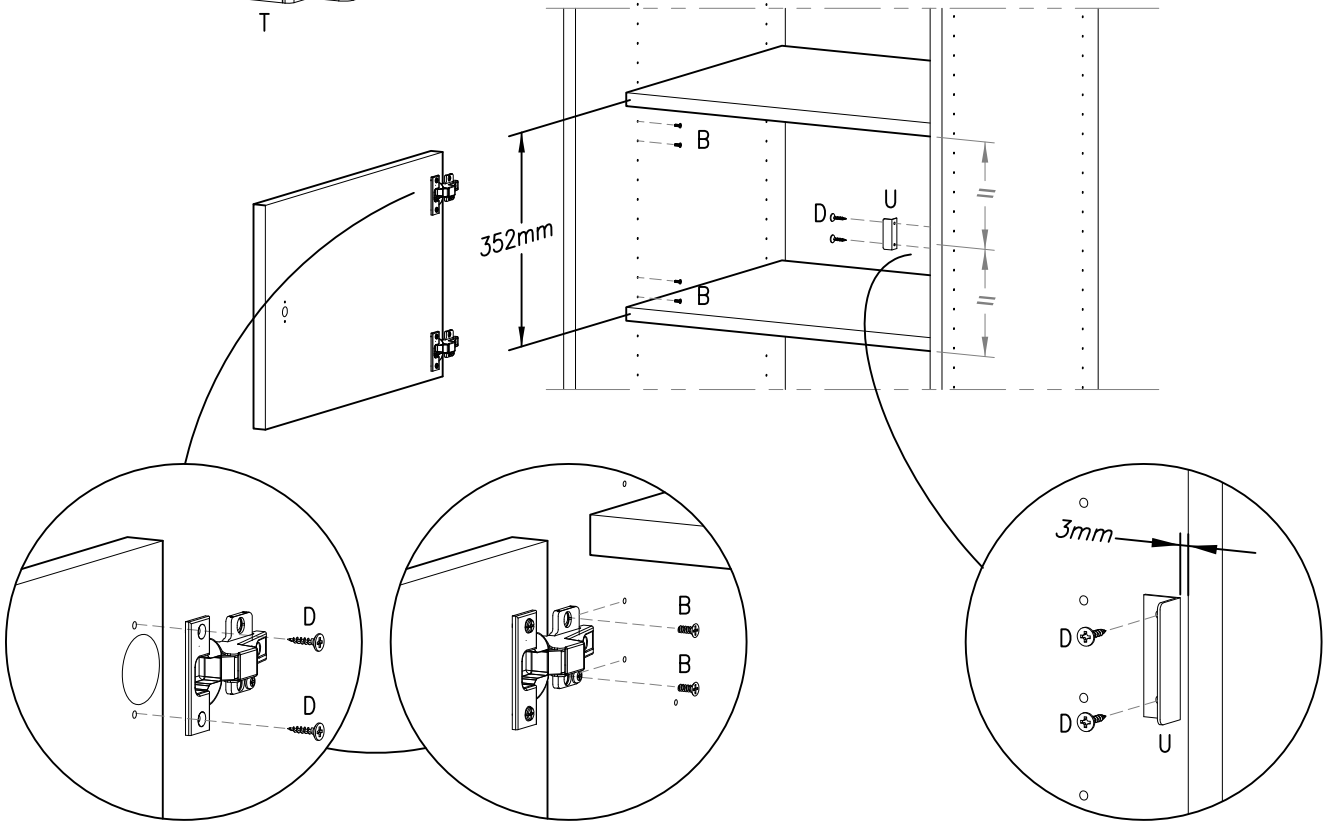
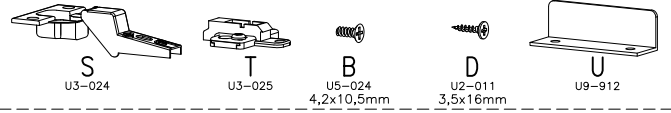
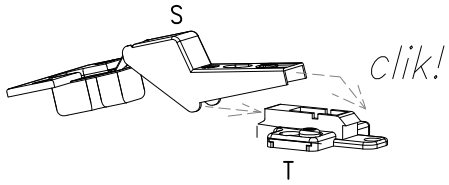

FIG. 27



Justering - Justierung - Adjusting - Réglage - Bijstelling - Ajuste - Regolazione - Ajuste

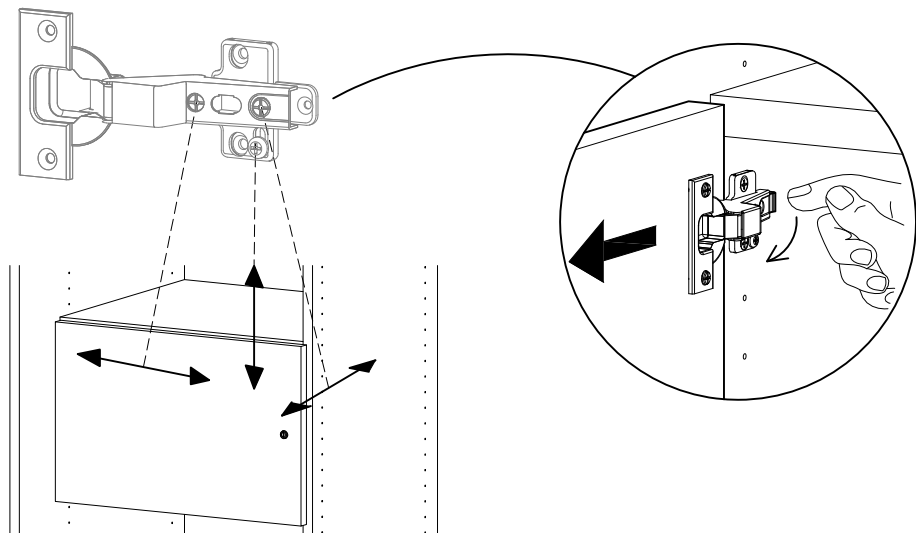

FIG. 28

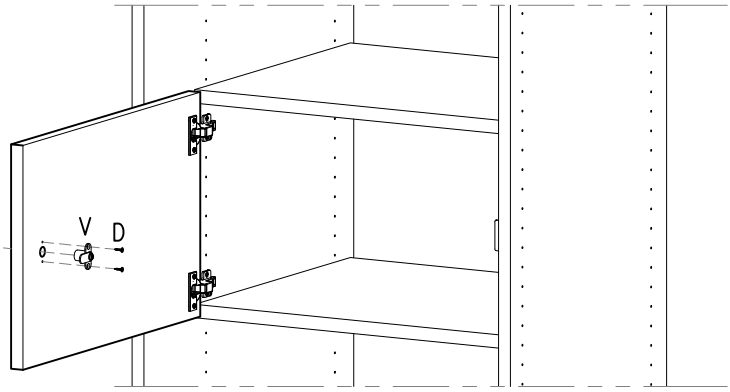
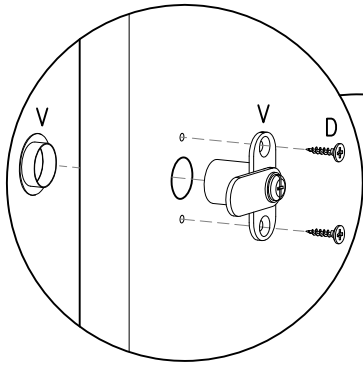
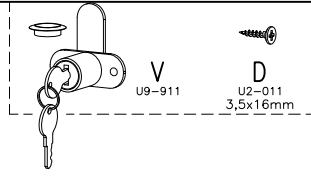

FIG. 29

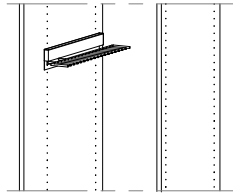
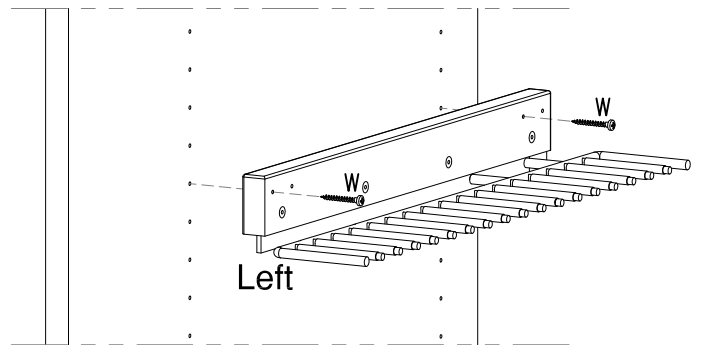
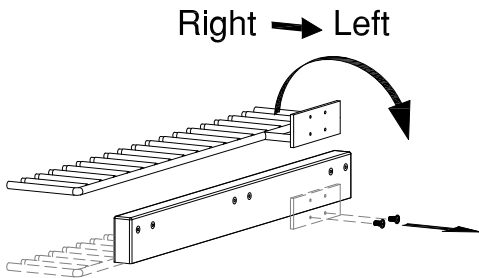
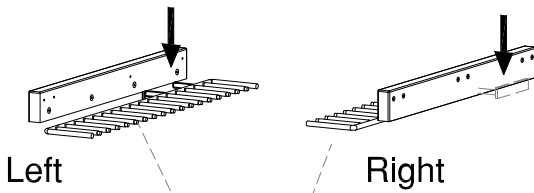

FIG. 29



- DK Ved reklamation oplyses følgende:
- D Im Reklamationsfall, bitte folgendes erläutern:
- US In case of claims, please state the following:
- F En cas de réclamation, veuillez indiquer:
- NL Bij service volgene mededelen
- E En caso de reclamación, indicar lo siguiente:
- P No caso de reclamação, por favor indique o seguinte:
- JP お気づきの点等ございましたら、以下の点をお知らせください。

Example!

