

User Manual

GOODWE SS SERIES

Table of Contents

1 Symbols	01
2 Safety	02
3 Installation	04
3.1 Mounting Instruction	04
3.2 Unpacking	04
3.3 Equipment Installation	06
3.4 Electrical Connection	09
3.5 Troubleshooting	18
4 System Operation	21
4.1 Display	21
4.2 Indicator Lights	21
4.3 LCD display	22
4.4 Error Message	28
5 Technical Parameters	29
GW1500-SS GW2000-SS GW3000-SS	29
GW4000-SS GW4600-SS	32
6 Certificates	35
7 Warranty	36
7.1 Warranty Period	36
7.2 Warranty Card	36
7.3 Warranty Conditions	36
7.4 Scope of Warranty	37
8 Contact	38

1 Symbols



Caution! - Failure to observe a warning indicated in this manual may result in minor or moderate injury.



Danger of high voltage and electric shock!



Danger of hot surface!



Product should not be disposed as normal household waste.



This side up- The package must always be transported, handled and stored in such a way that the arrows always point upwards.



Components of the product can be recycled.



Fragile-The package/product should be handled carefully and never be tipped over or slung.



Stack limitation-4 units of identical packages that may be stacked in maximum.



Keep dry – The package/product must be protected from excessive humidity and must accordingly be stored under cover.



CE Mark



Residual voltage exists in the inverter; the inverter cannot be maintained within 5 minutes until the capacitor is fully discharged.

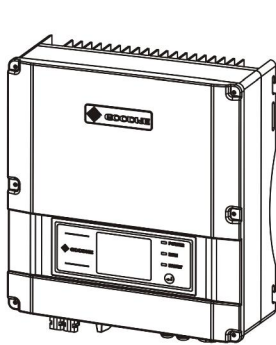

1.5-3KW

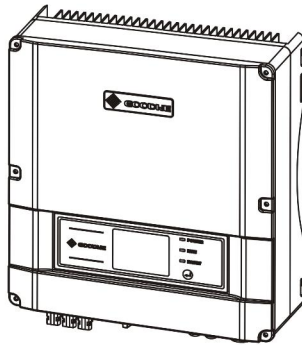

4-4.6KW

2 Safety

SS series inverter of Jiangsu GoodWe Power Supply Technology Co.,Ltd. (hereinafter referred to as GoodWe) strictly conforms to related safety rules in design and test. As electric and electronic equipment, Safety Regulation shall be followed during installation and maintenance. Improper operation may bring severe damage to the operator, the third party and other properties.

- ▶ The installation and maintenance of the inverters must be performed by qualified personnel only in compliance with national and local standards and regulations.
- ▶ Before installation and maintenance, DC input and AC output of the inverter should be cut off beforehand and the inverter cannot be touched within 10 minutes after power cut-off in case of electric shock.

- ▶ Partial temperature of the inverter may exceed 60°C during operation, please do not touch in case of scalding.
- ▶ All electric installation should conform to local electric standard and permission has to be obtained from local power supply department before synchronization by qualified personnel.
- ▶ Children must be kept away from inverters.
- ▶ Please do not open the front cover of inverter. Apart from wiring terminal, touching or changing components without authorization may cause damage to people and inverters. GoodWe may deny the obligation of warranty service accordingly.
- ▶ Static electricity may damage electronic components and proper measures shall be adopted to avoid static electricity.
- ▶ The output voltage of proposed PV array should be lower than the inverter maximum rated input voltage; otherwise, GoodWe will not undertake any obligations and warranty services.

3 Installation

3.1 Mounting Instruction

- A** In order to achieve optimal performance, the ambient temperature should be lower than 45 °C.
- B** For the convenience of checking the LCD display and possible maintenance activities, please install the inverter at eye level.
- C** Inverters should NOT be installed near inflammable and explosive items. Any electro-magnetic equipment should be kept away from installation site.
- D** Product label and warning symbol shall be clear to read after installation.

3.2 Unpacking

When you receive GoodWe inverter, please check if there is any visible external damage on the inverter or any accessories. Please also check if there is anything missing according to the list below.

Inverter	1
Wall-mounted bracket	1
Positive DC Plug (GW1500-SS)	1
Negative DC Plug (GW1500-SS)	1
Positive DC Plug (GW2000-SS / GW3000-SS)	2
Negative DC Plug (GW2000-SS / GW3000-SS)	2
Positive DC Plug (GW4000-SS / GW4600-SS)	3

Negative DC Plug (GW4000-SS / GW4600-SS)	3
Unlock Tool for DC Plug	1
AC Plug	1
USB Data Cable	1
Expansion Bolt	7
Flat Head Screw for RS485 Cover	4
User Manual	1
Warranty Card	1

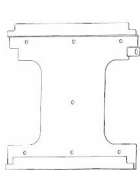

Wall-mounted Bracket

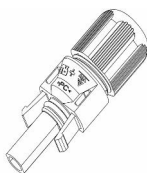

Positive DC Plug



Negative DC Plug



Unlock Tool for DC Plug



AC Plug



USB Data Cable

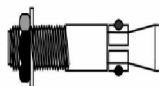

Expansion Bolt



Flat Head Screw



User Manual



Warranty Card



PV inverter

3.3 Equipment Installation

3.3.1 Selecting the installation position

Installation position should be selected based on the following aspects:

- ▶ The installation method and mounting location must be suitable for the inverter's weight and dimensions.
- ▶ Mount on a solid surface.
- ▶ Select a well ventilated place sheltered from direct sun radiation.
- ▶ Install vertically or tilted backward by max 15°. The device cannot be installed with a sideways tilt. The connection area must point downwards.

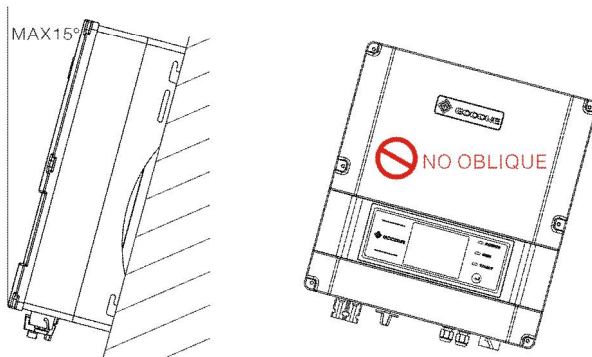

Figure 3.3.1-1

- ▶ In consideration of heat dissipation and convenient dismantlement, the minimum clearances around the inverter should be no less than the following value:

Upward	300mm
Downward	500mm
Front	300mm
Both sides	200mm

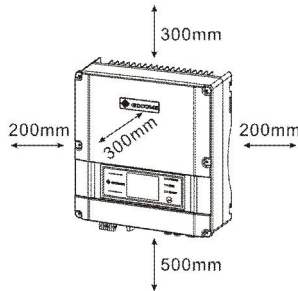

Figure 3.3.1-2

3.3.2 Mounting Procedure

- A Use the wall-mounted bracket as a template and drill 7 holes on the wall, 10 mm in diameter and 80 mm deep.

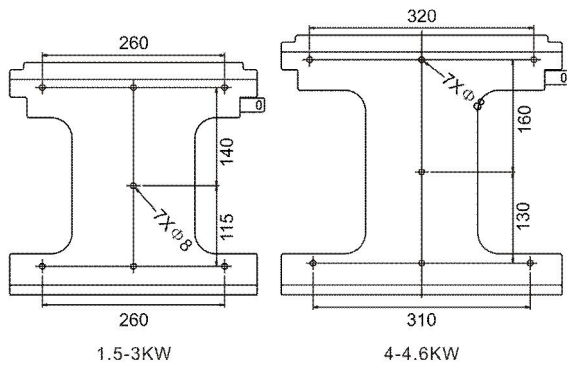

Figure 3.3.2-1

- B** Fix the wall mounting bracket on the wall with the expansion bolts in accessory bag.
- C** Carry the inverter by holding the groove on the heat sink.

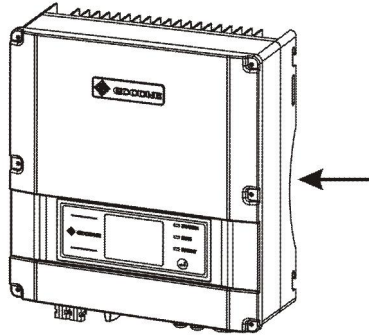

Figure 3.3.2-2

- D** Place the inverter on the wall-mounted bracket (as illustrated below).

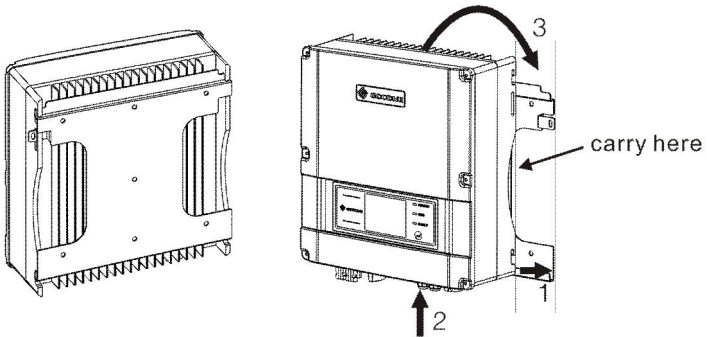

Figure 3.3.2-3

Figure 3.3.2-4

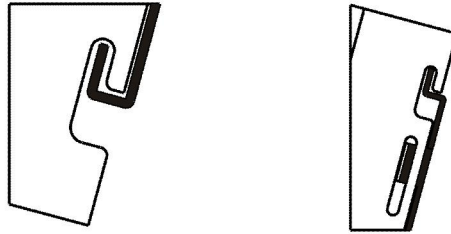

Figure 3.3.2-5

E Fix the inverter with a padlock

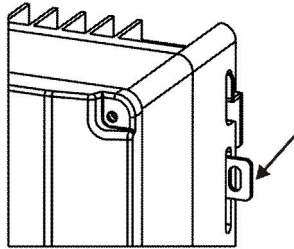

Figure 3.3.2-6

3.4 Electrical Connection

The inverter is compatible with RCD and RCM.

The DC component may produce electricity; as a result, a residual current operated protective (RCD) or monitoring device (RCM) will be used for protection in case of direct or indirect contact, only Type B RCD/RCM is allowed to be connected to the supply side of the product.

3.4.1 Connection to grid (AC side Connection)

- A** Check the grid (utility) voltage and frequency at the connection point of the inverter. It should be 230VAC (or 220VAC), 50/60Hz, and single phase.
- B** Disconnect the breaker or fuse between PV-Inverter and utility.
- C** Connect the inverter to the grid as follows:
 - ▶ Switch off the AC Breaker.
 - ▶ Disassemble female connector of the AC wire connector and connect AC wires to connection socket as indicated.

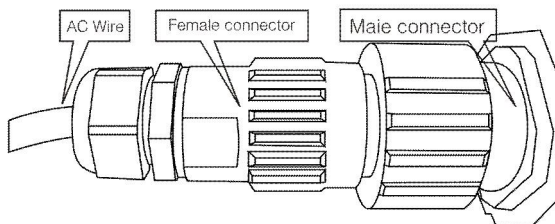



Figure 3.4.1-1

- ▶ Insert Line wire to Pin 1, Neutral wire to Pin 2 and Ground wire to Pin 

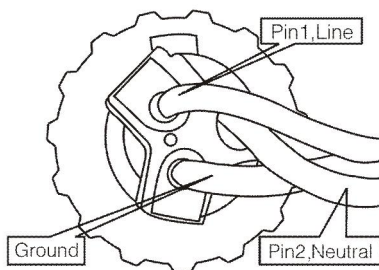

Figure 3.4.1-2

- ▶ After fastening all screws, reassemble the female connector of the AC wire connector.
- ▶ Connect the female connector of the AC wire connector to the Male connector on the inverter.

D Specifications of the AC wires:

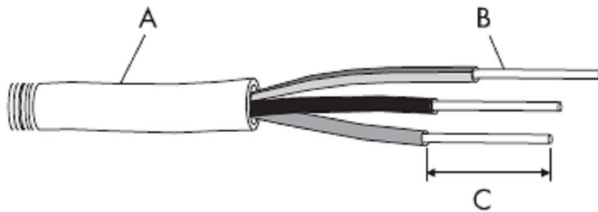

Figure 3.4.1-4

Depiction	Size
A External diameter of the wire	12mm-25mm
B Sectional area of conducting materials	Max.6mm ²
C Length of bare wire	Approx.10mm

3.4.2 DC side connection

- A** Make sure the maximum open circuit voltage (Voc) of each PV string does not exceed the inverter input voltage Vmax under any condition.
- B** Use Multi-contact connectors for PV array terminals.
- C** Connect the positive and negative terminals of the PV panel to

corresponding terminals on the Inverter. The DC terminal on each Inverter can bear 20A DC current.

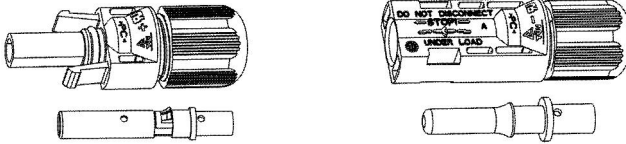

Female side connector (PV+)

Male side connector (PV-)

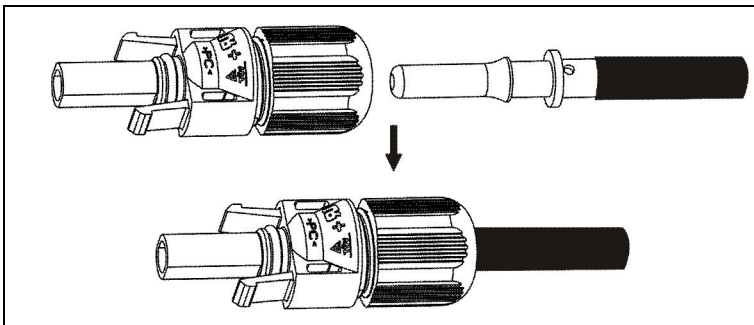
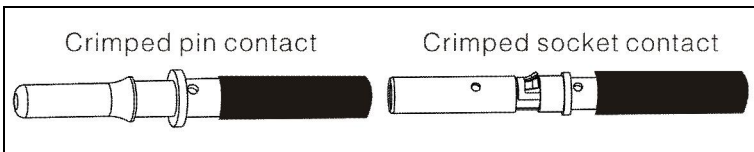
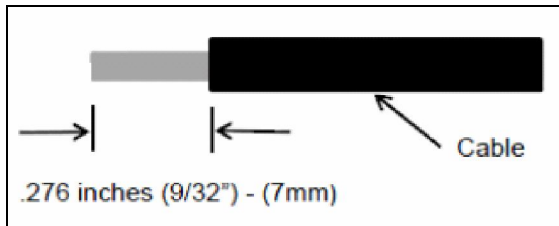

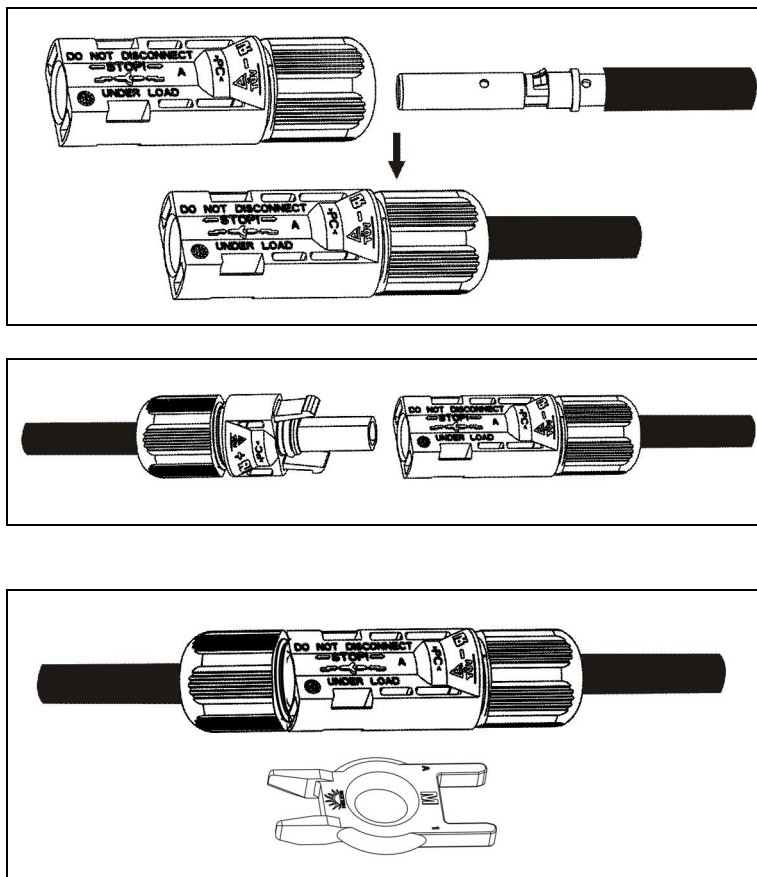

Figure 3.4.2-1 Separated by Ring tool



- ▶ Before connecting the PV panels, please ensure the plug connectors have the correct polarity. Incorrect polarity connection could permanently damage the unit.

- ▶ Checks short-circuit current of the PV string. The total short-circuit current of the PV string cannot exceed the inverter's maximum DC current.
- ▶ High voltage exists when the PV panel is exposed to the sun. Please secure the terminal connection, and do NOT touch any exposed components in case of electric shock.

3.4.3 RS485 Communication

RS485 interface is used for multipoint communication. EzLogger can monitor and communicate with 50 inverters at the same time. But the maximum length of the cable should not exceed 1000 m. All the inverters, which communicate through one cable, should use provided RS485 interface. The typical inverter connection graph through RS485 is shown below.

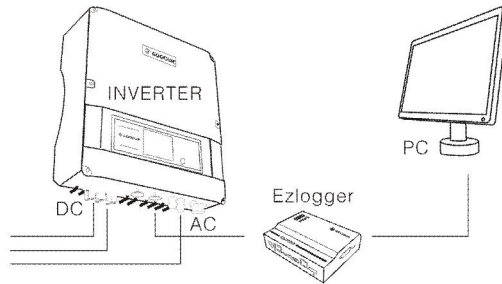

Figure 3.4.3-2

The graph below shows the monitoring system connection, in which inverters' multipoint communication can be realized

through RS485 interface. The software “EzExplorer” used in PC end can realize real-time monitoring of 16 EzLoggers at the same time.

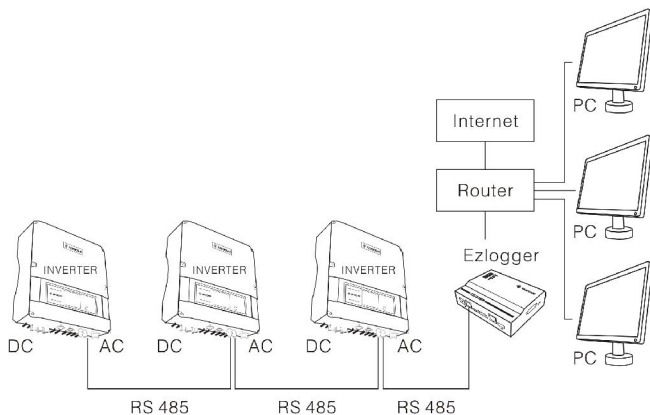

Figure 3.4.3-2

Pins of RS485 of GoodWe SS series:

Pin1-----TX_RS485A	
Pin2-----TX_RS485B	
Pin3-----RX_RS485A	
Pin4-----GND	
Pin5-----GND	
Pin6-----RX_RS485B	
Pin7-----+7V	
Pin8-----+7V	

A Connection procedure:

- a.** Screw off the RS485 cover;

- b. Remove the screw cap of the cable gland;
- c. Remove one-hole sealing ring;
- d. Put RS485 cable through the components in this order:
screw cap, one-hole sealing ring, gland body;
- e. Compress the crystal head and insert it into corresponding interface;
- f. Fasten the waterproof of RS485 Cover;
- g. Fasten the screw cap of the cable gland.

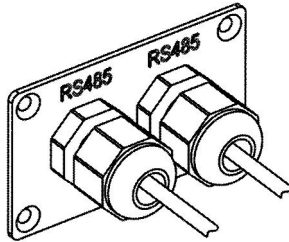

Figure 3.4.3-3

- B** RS485 cable is composed by eight wires with different colors. Chop the envelope outside to expose the eight wires, then straighten the end of every wire, and put them in order.

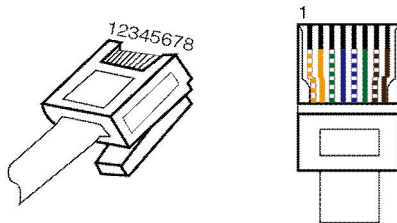

Figure 3.4.3-4

- C** The connection between crystal connectors and RS485 wires must be corresponding with each other, as shown in the table below.

The number of the pins of crystal connector	Color of the RS485 wires
	Orange and white
	Orange
	Green and white
	Blue
	Blue and white
	Green
	Brown and white
	Brown

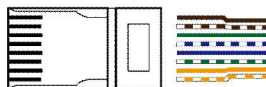

Figure 3.4.3-5

- D** Plug the eight wires into corresponding slots of the crystal connector, and then fix them up using special tool below.

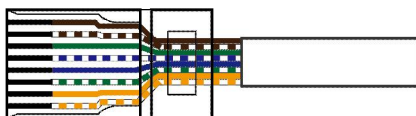

Figure 3.4.3-6

- E** Connect the other end of RS485 cable to crystal connector according to procedure 3 and 4.
- F** The inverter can communicate with an EzLogger through RS485 cable. When EzLogger is connected to PC via Ethernet or USB interface, the inverter can communicate with PC directly.

3.4.4 USB Communication

USB data cable must be connected as below

- A Take off the USB socket cover
- B Insert USB cable as the arrow pointed out

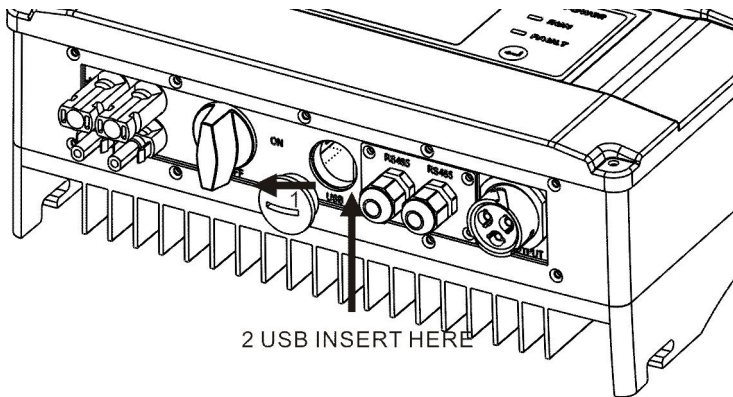

Figure 3.4.4-1

3.5 Troubleshooting

- ▶ In most situations, the Inverter requires very little maintenance. However, if the Inverter is not able to work properly, please refer to the following instructions before calling your local dealer.
- ▶ Should any problems arise, the red (Faulty) LED indicator on the front panel lights up and the LCD screen will display relevant information. Please refer to the following table for a list of error message and associated solutions.

	Display	Possible actions
System Fault	Isolation Fault	<ol style="list-style-type: none"> 1. Check the impedance between PV (+) & PV (-) and make sure the PV-Inverter is earthed. The impedance value must be greater than 2MΩ. 2. Contact local service office for help if the problem still exists.
	Ground I Fault	<ol style="list-style-type: none"> 1. The ground current is too high. 2. Unplug the inputs from the PV generator and check the peripheral AC system. 3. When the problem is cleared, reconnect the PV panel and check the Inverter status. 4. Contact local service office for help if the problem still exists.
	Vac Failure	<ol style="list-style-type: none"> 1. The PV Inverter will automatically restart within 5 minutes if the grid returns to normal. 2. Make sure grid voltage is in conformity with the specification. 3. Contact local service office for help if the problem still exists.
	Fac Failure	<ol style="list-style-type: none"> 1. The PV Inverter will automatically restart within 5 minutes if the grid returns to normal. 2. Make sure grid frequency is in conformity with the specification. 3. Contact local service office for help if the problem still exists.
	Utility Loss	<ol style="list-style-type: none"> 1. Grid is not connected. 2. Check grid connection cables. 3. Check grid usability.
Inverter Failure	PV Over Voltage	<ol style="list-style-type: none"> 1. Check whether the PV open voltage is higher or too close to the maximum input voltage. 2. If the problem still exists when PV voltage is less than the maximum input voltage, contact local service office for help.

Consistent Fault	<ol style="list-style-type: none"> 1. Disconnect PV (+) or PV (-) from the input and restart the PV Inverter. 2. If the problem still exists, contact local service office for help.
Over Temperature	<ol style="list-style-type: none"> 1. The internal temperature is higher than normal value specified. 2. Reduce ambient temperature. 3. Move the inverter to a cool place. 4. If the problem still exists, contact local service office for help.
Relay-Check Failure	<ol style="list-style-type: none"> 1. Disconnect all PV (+) or PV (-). 2. Wait for a few seconds. 3. After the LCD switches off, reconnect and check again. 4. If the message appears again, contact local service office for help.
DC Injection High	
EEPROM R/W Failure	
SCI Failure	
DC Bus High	
Ref 2.5V Fault	
GFCI Failure	

- ▶ If there is no display on the panel, please check PV-input connections. If the voltage is higher than 125V, contact local service office for help.
- ▶ When sunlight is insufficient, the PV Inverter may continuously start up and shut down automatically due to insufficient power generated by the PV panel. If the problem remains, please contact the local service office.

4 System Operation

4.1 Display

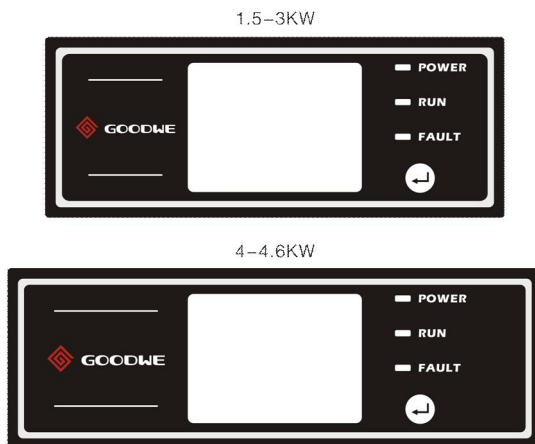

Figure 4.1-1

4.2 Indicator Lights

- ▶ Yellow: light on indicates the inverter is electrified; light off means the inverter is not electrified.
- ▶ Green: light on indicates the inverter is feeding power; light off means the inverter is not generating power at the moment.
- ▶ Red: light on indicates abnormal conditions appear; light off means there is no abnormal condition.

4.3 LCD Display

A The schematic of display screen is shown below:

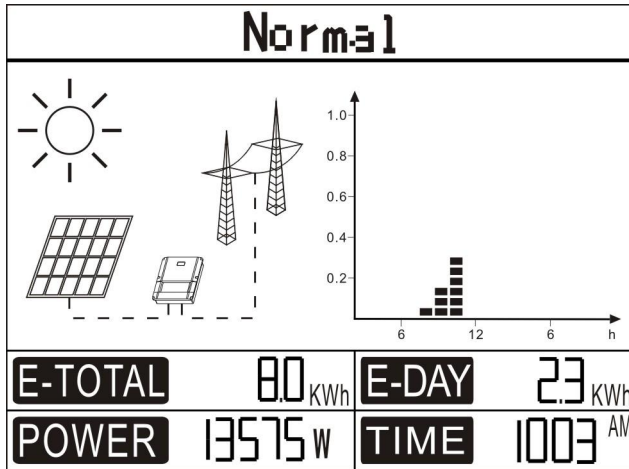

Figure 4.3-2

B Display area

Display area is divided into top area, middle area and bottom area.

Top area: displaying status information.

- ▶ This area displays the status information. “Waiting” indicates the inverter is standby for power generation; “Checking 30S” (checking time based on safety varies from country to country) indicates the inverter is self-checking, counting down and preparing for power generation; “Normal” indicates the inverter is generating power; if any condition of the system is abnormal, the screen will display error message, please refer to Table 5.4-1.
- ▶ Through key operation, the screen can display different information such as operation parameters and power generation status in this area. There are two levels of menus, and the flow chart of first level menu is shown below:

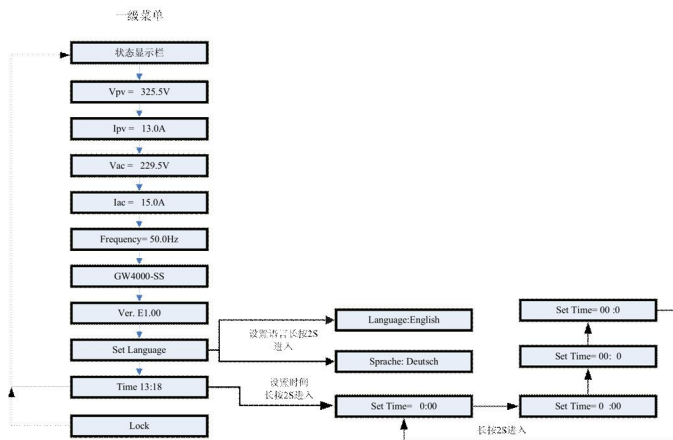

Figure 4.3-3

- ▶ Menu display can be controlled by pressing the key; Holding the key for a while will enter into the submenu.

Middle area, Left:

- ▶ The electrical connection status on DC side and AC side are represented by dashed line and full line. Flashing dashed line on DC side indicates PV panel is feeding power to the inverter; Nothing shows on AC side means grid is not available; full line on AC side means grid is available, but the inverter is not generating power at the moment; flashing dashed line on AC side indicates the inverter is feeding power to the grid network.

Middle area, Right:

- ▶ In this area, histogram is used to represent the hourly average power generation from 4 a.m. to 8 p.m. at the same day. The

average power at full column represents the nominal power of system.

Bottom area:

Bottom area displays total power generation, daily power generation, and power generated at present and time information, described as follow:

Part	Description
E-TOTAL	Gross power generated from the first time use of inverter. The initial unit is “kWh”; When power generation exceeds 9999.9kWh, the unit changes to “MWh”.
E-DAY	Power generated the same day
POWER	Instant power generation of the system
TIME	Current system time

C Key operation:

There are 5 modes of key operation:

Short press, Long press 2S, Long press 3S, Long press 5S, Long press 10S

D Key operation and LCD description:

- ▶ Key operation is mainly for language and time setting. Clients can also find the information they concern through key operation.
- ▶ The menu in LCD display area has two levels, you can hold the key to enter second-level menu; long press the key 2S to lock the current interface if there is no second-level menu.

- ▶ In all levels of menu, it will automatically enter the first item of the first level menu if no action is taken within 10S, meanwhile, the modified data will be stored into internal memory.

E Menu Introduction

- ▶ When PV panel is feeding power to the inverter, the screen shows the first-level menu.
- ▶ Initial display is the first interface of the first-level menu and the interface displays current state of the system. It shows “Waiting” in the initial state; it shows “Normal” during power generation mode; if there is something wrong with the system, error message is shown. Please see 5.4 for fault code.
- ▶ Short press the key once to enter Vpv menu which displays the PV voltage in“V”.
- ▶ Short press the key once to enter Ipv menu which displays the PV current in“A”.
- ▶ Short press the key once to enter Vac menu which displays the grid voltage in“V”.
- ▶ Short press the key once to enter Iac menu which displays the grid current in“A”.
- ▶ Short press the key once to enter Frequency menu which displays the grid frequency in“Hz”.
- ▶ Short press the key once into ModelName menu under which submenu can be found.
- ▶ Short press the key once to enter the software version menu which shows the current software version used. The LCD

backlight will be off without any operation within 10S, LCD display will automatically return to main menu.

- ▶ Short press the key once to enters language display menu. Press the button for 2S to enter the second level menu. The circulatory submenu including two languages can be found. The language can be chosen by short pressing the key. The inverter will store the chosen language without any action within 10S and LCD display will automatically return to main menu when the backlight is off.
- ▶ Short press the key once to enter time display menu which is used to display the current time. Long press the key for 2S to enter the submenu to set the time of the inverter. The initial display is “Set Time = 00: 00”, in which the first number will be flicking firstly and number“0”, “1”, “2”can be chosen by shortly pressing the button. Then hold the key for 2 to set the second number. Number 0-9 can be chosen by short pressing the key. “Minute” can be set with the same steps as the “hour”. The inverter will store the time without any action in 10S and LCD will automatically return to main menu when the backlight is off.
- ▶ Long press the key 2S in the menu with no submenu, LCD will display “Lock” and then this menu will be locked after 1S.
- ▶ In order to check Vpv value, enter Vpv menu first, long press the key 2S, the screen will display “Lock” first and Vpv value afterwards.
- ▶ The locked menu can only be unlocked under system mode

switching, fault occurrence or key operation.

F Normal Start and Operation Display.

- ▶ When the input voltage reaches inverter turn-on voltage, LCD starts to work, the yellow light is on, LCD displays “waiting”, more information will be displayed within a few seconds. If the inverter is connected to the grid, “Checking 30” will be shown up in 2S, counting down from 30S, when it shows “00S” you can hear the reply triggered 4 times, LCD displays “Normal” afterwards. The instant power output will be shown at the left bottom of LCD.

4.4 Error message

An error message will be displayed on LCD interface when a disturbance occurs.

Table 5.4-1 Description of Error Message

Error message	Description
Utility Loss	Grid disconnected
Fac Failure	Grid frequency no longer within permissible range
Consistent Fault	Machine parameter consistent fault
Device Fault	Device internal fault
PV Over Voltage	Overvoltage at DC input
Over Temperature	Overtemperature on the case

Isolation Fault	Ground insulation impedance is too low
Ground I Fault	Overhigh ground leakage current
Relay-Check Failure	Relay self-checking failure
DC Injection High	Overhigh DC injection
EEPROM R/W Failure	Memory chip failure
SCI Failure	Internal communication failure
DC Bus High	Overhigh BUS voltage
Ref 2.5V Fault	2.5V reference voltage failure
AC HCT Failure	Output current sensor failure
GFCI Failure	Detection circuit of ground leakage current failure
Vac Failure	Grid voltage no longer within permissible range

5 Technical Parameters

Table 5.1 GW1500-SS, GW2000-SS, GW3000-SS

Model Name	GW1500-SS	GW2000-SS	GW3000-SS
DC input data			
Max. PV-generator power [W]	1800	2300	3200
Max. DC Voltage [V]	450	500	500
MPPT voltage range [V]	125~450	125~450	125~450
Turn on DC Voltage [V]	125	125	125
Turn off DC Voltage [V]	90	90	90
Max. DC work current [A]	12	15	18
Max.PV array short current[A]	15	18	20
Number of DC connection	1	2	2
Number of MPP trackers	1	1	1
DC-connection	MC IV Connector		
Turn on power [W]	5	5	5
Night power[W]	0	0	0
Output data			
Nominal AC power	1500W	2000W	3000W
Max.AC power	1650W	2000W	3000W
Max.output current[A]	8	10	15
Nominal output voltage range	According to VDE0126-1-1/A1,RD1663,ENEL,G83,G59,SAA		

AC grid frequency	According to VDE0126-1-1/A1,RD1663,ENEL,G83,G59,SAA		
THD(AC output current)	<1%		
Power factor	~ 1(Nominal power)		
AC Connector	Single phase with Clamps		
Efficiency			
Max. efficiency	97.0%	97.0%	97.0%
Euro efficiency	>96%	>96%	>96.5%
MPPT adaptation efficiency	>99.5%	>99.5%	>99.5%
Safety equipment			
DC reverse polarity protection	Integrated(with diode)		
Leakage current monitoring unit	Integrated		
AC short protection	Integrated		
DC disconnecter switch	Integrated		
Islanding protection	AFD		
Grid Monitoring	According to VDE0126-1-1/A1,AS4777.1/2/3,RD1663,ENEL Guied,G83,G59-2		
Normative reference			
EMC compliance	According to EN 61000-6-1,EN 61000-6-2,EN 61000-6-3,EN 61000-6-4		
Safety compliance	According to IEC62109-1, AS3100		
General data			

Dimensions (WxHxD) [mm]	330*350*125	
Net Weight [kg]	12	13
Housing	For outdoor and indoor	
Mounting information	Wall bracket	
Operating temperature range	-20~60°C (up 45°C derating)	
Relative humidity	0~95%	
Site altitude	2000m	
IP protection type	IP65	
AC Over voltage category	Category 2	
DC Over voltage category	Category 3	
Protective Class	Class 1	
Topology	Transformerless	
Cooling concept	Nature Convection	
Noise level	<25dB	
Display	3 LED; 4" LCD	
Data logger	485(wireless /Bluetooth optional)	
Data communication interfaces		
Computer Communication	USB	
Standard warranty	5years/10 years((optional)	

Table 5.2 GW4000-SS, GW4600-SS

Model Name	GW4000-SS	GW4600-SS
DC input data		
Max. PV-generator power [W]	4600	5400
Max. DC Voltage [V]	580	580
MPPT voltage range [V]	125~550	125~550
Turn on DC Voltage [V]	125	125
Turn off DC Voltage [V]	90	90
Max. DC work current [A]	20	20
Max.PV array short current[A]	27	27
Number of DC connection	3	3
Number of MPP trackers	1	1
DC-connection	MC IV or HC IV-connector	
Turn on power [W]	5	5
Night Power [W]	0	0
Output data		
Nominal AC power	4000W	4600W
Max.AC power	4400W	5100W
Max.output current [A]	22	25
Nominal output voltage range	According to VDE0126-1-1,RD1663,ENEL,GB,SAA	
AC grid frequency	According to VDE0126-1-1,RD1663, ENEL,GB,SAA	

THD(AC output current)	<2%	
Power factor	~1(Nominal power)	
AC Connector	Single phase With Clamps	
Efficiency		
Max. efficiency	97.8%	97.8%
Euro efficiency	>97.4%	>97.4%
MPPT adaptation efficiency	>99.5%	>99.5%
Safety equipment		
DC reverse polarity protection	Integrated(with diode	
Leakage current monitoring unit	Integrated	
AC short protection	Integrated	
DC disconnecter switch	Integrated	
Islanding protection	AFI	
Grid Monitoring	According to VDE0126-1-1,RD1663,ENEL,GB,SAA	
Normative reference		
EMC- compliant according to	EN 61000-6-1,EN 61000-6-2,EN 61000-6-3,EN 61000-6-4	
Safety compliance	According to IEC62109-1, AS3100	
General data		
Dimensions (WxHxD) [mm]	390*417*142	
Net Weight [kg]	18	
Housing	For outdoor and indoor	

Mounting information	Wall bracket
Operating temperature range	-20~60°C (up 45°C derating)
Relative humidity	0~95%
Site altitude	2000m
IP protection type	IP65
AC Over voltage category	Category 2
DC Over voltage category	Category 3
Protective Class	Class 1
Topology	Transformerless
Cooling concept	Natural convection
Noise level	<25dB
Display	3 LED; 4"LCD
Data logger	485(Wireless/Bluetooth optional)
Data communication interfaces	
Computer Communication	USB2.0
Standard warranty	5years/10 years(optional)

6 Certificates



7 Warranty

7.1 Warranty Period

GoodWe provides standard warranty period of 5 years for SS series products (Warranty period begins from the date on purchase invoice). Additional provision will be subject to contract.

7.2 Warranty Card

Warranty card and purchase invoice should be properly kept within product warranty period. Meanwhile, the nameplate on products shall be clear to read. Otherwise GoodWe may deny the warranty service or only provide paid service.

7.3 Warranty Conditions

According to GoodWe product description and instruction, if a device becomes defective within warranty period, and it is proved that further functional performance is impossible due to product quality problem, the device will be, as selected by GoodWe:

- A** Return to the factory for maintenance;
- B** Onsite maintenance;
- C** Products Replacement (if the original model has stopped in production, GoodWe will provide a replacement device of equivalent value according to model and age.).

7.4 Scope of Warranty

Warranty declaration is excluded in the following situations:

- ▶ Products or fittings exceed warranty period (exclude the warranty extension agreement signed beforehand).
- ▶ Fault or damage due to improper operation without following user manual, product instruction, and relevant safety regulations.
- ▶ Insufficient ventilation of the unit
- ▶ Fault or damage due to improper installation, repair, change or removal by persons who are not authorized by GoodWe.
- ▶ Fault or damage due to unpredictable accidental factors, human errors or force majeure.
- ▶ Fault or damage which is not caused due to products quality problem.

8 Contact

If you have any enquiries or technical problems concerning GoodWe SS series inverter, please contact our customer services.

Add: No.189 Kun Lun Shan Road, Suzhou New District, Jiangsu, China (Jiangsu GoodWe Power Supply Technology Co., Ltd.)

Tel: + 86 512 6239 7998

Fax: + 86 512 6239 7972

E-mail: service@goodwe.com.cn

Website: www.goodwe.com.cn