



Optigo OP5 Manual

©Copyright AB Regin, Sweden, 2007

READY STEADY GO



THE CHALLENGER IN BUILDING AUTOMATION

ANSVARSBEGRÄNSNING

All information i detta dokument har kontrollerats noggrant och bedöms vara korrekt. Emellertid lämnar Regin inga garantier vad gäller manualens innehåll. Användare av denna manual ombeds rapportera felaktigheter, tvetydigheter eller oklarheter till Regin, för eventuella korrigeringar i framtida utgåvor. Informationen i detta dokument kan ändras utan föregående meddelanden.

Ingen del av detta dokument får återges eller överföras i någon form eller på något sätt, elektroniskt eller mekaniskt, för något som helst ändamål utan uttryckligt skriftligt medgivande från Regin.

COPYRIGHT

© AB Regin. Med ensamrätt.

VARUMÄRKEN

Optigo är ett registrerat varumärke som tillhör AB Regin.

Andra produktnamn som förekommer i detta dokument används enbart i identifieringssyfte och kan vara ägarens registrerade varumärken.

DISCLAIMER

The information in this manual has been carefully checked and is believed to be correct. Regin however, makes no warranties as regards the contents of this manual and users are requested to report errors, discrepancies or ambiguities to Regin, so that corrections may be made in future editions. The information in this document is subject to change without prior notification.

No part of this document may be reproduced or transmitted in any form, in any fashion, electronically or mechanically, without the express, written permission of Regin.

COPYRIGHT

© AB Regin. All rights reserved.

TRADEMARKS

Optigo is a registered trademark of AB Regin.

Some product names mentioned in this document are used for identification purposes only and may be the registered trademarks of their respective companies.

mars 2007

Document number: X1nnn

Document Revision: 2007-0-00

Table of contents

<i>Chapter 1 About this manual</i>	4
Terms	4
More information	4
<i>Chapter 2 Introduction to Optigo</i>	5
Optigo controllers	5
<i>Chapter 3 Technical data</i>	7
<i>Chapter 4 Installation and wiring</i>	8
Installation	8
Wiring	8
Supply voltage.....	8
Inputs and outputs	9
<i>Chapter 5 Control modes</i>	10
Control mode 1, Temperature control.....	10
Control mode 2, CO ₂ control	12
Control mode 3, Humidity control	13
Control mode 4, Pressure control.....	14
Control mode 5, Pressure control with outdoor temperature compensation of the pressure setpoint.....	15
<i>Chapter 6 Display and encoder</i>	16
The Basic level.....	16
The 10-second level	17
Display symbols.....	17
<i>Chapter 7 Setpoint</i>	18
<i>Chapter 8 Configuration</i>	19
Menus 1.0 – 5.0.....	19
Menu X.1 Output signals (Control mode 1 only), Transmitter range (Control modes 2, 3, 4 and 5).....	19
Menus X.2 Neutral zone (Control mode 1 and 3)	20
Menus X.3 P-band.....	20
Menus X.4 I-time	21
Menu 1.5 Damper minimum position (Control mode 1 only).....	21
Menu 5.7 Start point for outdoor compensation (Control mode 5 only)	21
Menu 5.8 Maximum compensation (Control mode 5 only)	21
Menus X.9 I/O.....	22
Menu OK	22
Storage of settings.....	22
<i>Chapter 9 Index</i>	23

Chapter 1 About this manual

This manual describes the controller Optigo 5.

Terms

A few terms used in this manual:

FS Factory setting, the parameter value set on delivery

More information

- More information on OP5 can be found in:
- *Optigo controllers* – Sales brochure for Optigo controllers
- *Optigo product instruction*

The information can be downloaded from the Regin website, www.regin.se.

Chapter 2 Introduction to Optigo

Optigo controllers

Optigo is a new series of pre-programmed, configurable controllers that can be set to handle everything from temperature control or humidity control to CO₂ control or pressure control.

OP 5 och OP 10

The Optigo series comprises two different types, OP5 and OP10.

OP5 has 5 inputs/outputs and can be configured to control Temperature, CO₂, Humidity or Pressure

OP 10 has 10 inputs/outputs and can be configured to control Temperature (ventilation control with heating and cooling), Waterheated radiator-heating with outdoor temperature dependent control-curve or Tap hot-water control. OP10 als has a week-based scheduler. OP 10 is available in two versions, OP 10 with 24 V AC supply voltage and OP 10-230 with 230 V AC supply voltage. For more information, please refer to the separate Optigo OP10 manual.

Mounting

Optigo is designed primarily for DIN-rail mounting but can also be screw-mounted to any suitable surface.



Optigo OP5

Optigo OP5 is a new pre-programmed, configurable controller. It has been designed with the main intention of replacing a number of Regin's Aqualine controllers.

All configuration and normal handling is done using the display and the knob on the front.

Optigo is designed primarily for DIN-rail mounting but can also be screw-mounted to any suitable surface.

In- and Outputs

Optigo OP5 has

- 1 analogue input, PT1000
- 1 universal input, 0...10 V DC or digital
- 1 digital input
- 2 analogue outputs, 0...10 V DC

Control modes

Optigo OP is pre-programmed with a choice of 5 different control modes:

- Temperature control
- CO₂ control
- Humidity control
- Pressure control
- Pressure control with outdoor-temperature dependent compensation

Chapter 3 Technical data

Supply voltage.....	24 V AC \pm 15%, 50...60 Hz
Internal consumption.....	6 VA
Ambient temperature.....	0...50°C
Ambient humidity	Max 90% RH
Storage temperature.....	-20...70°C
Terminals.....	Disconnectable, so-called lift type for cable cross-section 2.5 mm ²
Protection class.....	IP20
Material casing	Polycarbonate, PC
Colour	
Cover	Silver
Bottom part.....	Dark gray
Weight	215 g incl. terminals
Dimensions.....	123 x 123 x 60 mm (WxHxD incl. terminals)

LVD, Low Voltage Directive

This product conforms with the requirements of European LVD standard IEC 60 730-1

EMC emissions an immunity standard

This product conforms with the requirements of European EMC standards CENELEC EN 61000-6-1 and EN 61000-6-3 and carries the CE mark

Inputs

AI	PT1000-sensor. Range -30...+54°C
A _{GND}	Reference for AI and for UI when used as an analogue input
DI	Closing potential-free contact
DI+	Reference for DI
UI	AI: 0...10 V DC or DI: Closing potential-free contact
UI+	Reference for UI when used as a digital input

Output

AO.....	0...10 V DC; 8 bit D/A short-circuit protected
---------	--

Other data

Display	Numeric / graphic. Background illumination
---------------	--

Accessories

External temperature sensors.....	TG-R5/PT1000, TG-KH/PT1000
CO ₂ -sensor	CO2RT, CO2RT-D, CO2DT
Humidity sensor	HRT, HRT250, HDT3200, HDT2200
Pressure sensor	DMD, DTL-series, DTK-series, TTK-series

The accessories are available from Regin. For more detailed information, see product sheets and instructions which are available at www.regin.se.

Chapter 4 Installation and wiring

Installation

Optigo can be mounted in a DIN-standard casing (minimum 7 modules), on a DIN-rail in a cabinet or, using a suitable front-mounting kit, in a cabinet door or other control panel. It can also be screwed to any suitable flat surface using the two screw-pockets provided.

Ambient temperature: 0...50°C.

Ambient humidity: max. 90 %RH, non-condensing.

Wiring

This section only describes general rules and technical limitations concerning the wiring. In chapter 5 there are specific wiring diagrams for the different control modes. Choose the one suitable for the application on hand.

It is important to make sure that the wiring is correctly done, in accordance with the instructions given in this manual and in accordance with local legislation for this type of installation.

1	G	24 V AC supply voltage
2	G0	
3	~	

20	AGND	Ref. for AO1 and AO2
21	AO1	0...10 V DC Output
22	AO2	0...10 V DC Output

41	DI+	Reference for DI1
42	DI1	Digital input
43	UI+	Reference for UI1 digital mode
44	UI1	0...10 V DC or Digital input
50	AGND	Ref. for AI1 and UI1 analogue
51	AI1	PT1000 temp. sensor input

Supply voltage

24 V AC $\pm 15\%$, 50...60 Hz. 6 VA

If the Optigo OP5 and active sensors and actuators connected to it share transformer, it is essential that the same transformer-pole is used as reference for all the equipment. Failure to do so will prevent the equipment from functioning as intended and may also lead to damages.

Inputs and outputs

A_{GND}

All A_{GND} terminals are interconnected and also connected to G0.

Analogue input AI

The analogue input must refer to an A_{GND} terminal. The analogue input is for PT1000 temperature sensors only. Temperature range: -30...+54°C.

Note: For temperatures below -9.9°C decimals will not be displayed. So make sure to differ between for example -2.7 (minus two point seven) and -27 (minus twentyseven).

Digital input DI

The digital input must refer to DI+ on terminal 41.

The digital input may only be wired to voltage-free contacts. Any external voltage applied to a digital input may seriously damage the unit.

Universal input UI

The universal input can, depending on the choice of application, be made to act as either an analogue input or as a digital input.

When used as an analogue input it is for 0...10 V DC input signals.

When the Universal input is used as an analogue input it must refer to the A_{GND} terminal or directly to G0.

When used as a digital input it must refer to UI+ on terminal 43. It may then only be wired to voltage-free contacts.

Analogue outputs

Analogue outputs must refer to a A_{GND} terminal or directly to G0.

If the Optigo OP5 and active sensors and actuators connected to it share transformer, it is essential that the same transformer-pole is used as reference for all the equipment. Failure to do so will prevent the equipment from functioning as intended and may also lead to damages.

Chapter 5 Control modes

Optigo can be configured to any one of the following control modes.

1. Temperature control.

The temperature at the sensor is kept at the setpoint value by controlling the output signals on AO1 and AO2. A single PI control loop is used.

2. CO₂ control.

The CO₂-value at the sensor is kept at the setpoint value by controlling the output signal on AO1.

A single PI control loop is used.

3. Humidity control.

The humidity at the sensor is kept at the setpoint value by controlling the output signals on AO1 and AO2. AO1 is used for humidification, AO2 for dehumidification. A single PI control loop is used.

4. Pressure control.

The pressure at the sensor is kept at the setpoint value by controlling the output signal on AO1.

A single PI control loop is used.

5. Pressure control with outdoor compensation.

The pressure at the sensor is kept at the setpoint value by controlling the output signal on AO1. The setpoint is automatically adjusted according to the outdoor temperature. A single PI control loop is used.

Control mode 1, Temperature control

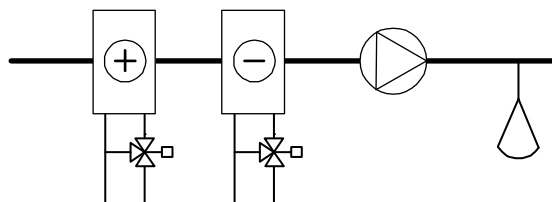

The analogue outputs can be configured to the following combinations:

- | | AO1 | / | AO2 |
|------------|-----|---|---------|
| 1. Heating | | / | - |
| 2. Cooling | | / | - |
| 3. Heating | | / | Cooling |

- 4. Heating / Heating
- 5. Cooling / Cooling
- 6. Heating / Damper
- 7. Cooling / Damper
- 8. Change-over/ - (Seasonal change-over between heating and cooling)

DI1, Start signal

Normal control will only be activated when this input is activated, closed. When the start signal is deactivated the controller will set the outputs to 0.

Note: This input must always be wired since it controls the starting and stopping of normal control.

Universal input UI1, Change-over

The change-over function will make a seasonal change of the function of the output signal on AO1. In summer the output will work as a cooling output and in winter as a heating output. This is used in applications (fan-coil units) where the same piping is used to transport hot water in the winter and chilled water in the summer.

The universal input UI1 is used for the change-over function in alternative 8. Wire the input as a digital input using either a manual switch or a thermostat monitoring the supply water temperature to open/close the input. Open contact will give heating control and closed contact cooling control.

Damper

In applications with dampers it is often desirable to be able to set a minimum amount of fresh air. In the output alternatives 6 and 7 it is possible to set a minimum limit value to the damper output signal. The damper output will then not go lower than the set value during normal operation. On shut-down however the signal will go to zero.

In the output mode heating – damper the damper will be fully open for temperatures higher than the setpoint. On increasing heat demand the damper will first close to the minimum value before the heating output starts to increase.

In the output mode cooling – damper the damper will be fully open for temperatures lower than the setpoint. On increasing cooling demand the damper will first close to the minimum value before the cooling output starts to increase.

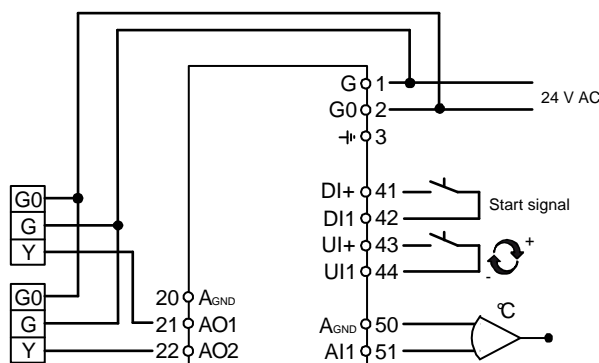

Control mode 2, CO₂ control

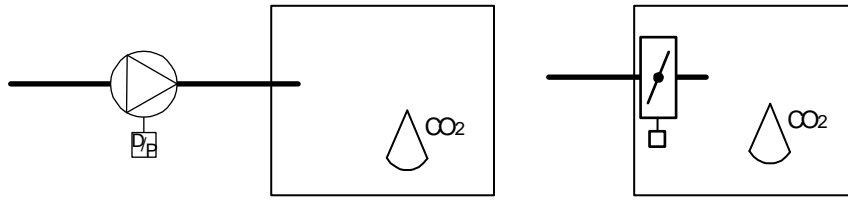

The output signal will increase when the CO₂-value rises above the setpoint value.

The CO₂-sensor must have a 0...10 V DC output for example:

CO2RT, CO2RT-D Room sensors

CO2DT Duct sensor

The transmitter range cannot exceed 5000 ppm at 10 V DC output.

DI1, Start signal

Normal control will only be activated when this input is activated, closed. When the start signal is deactivated the controller will set the output to 0.

Note: This input must always be wired since it controls the starting and stopping of normal control.

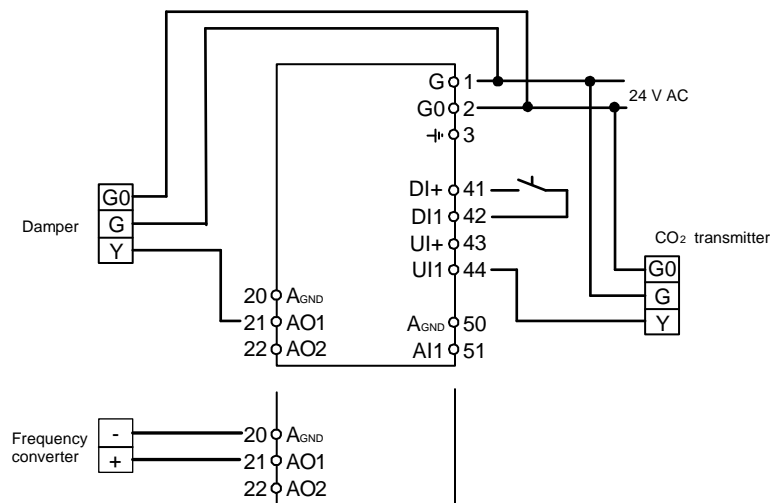

Control mode 3, Humidity control

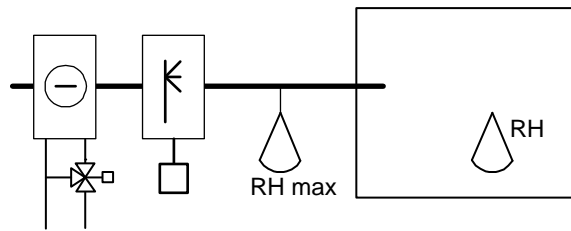

Humidification and dehumidification can be used simultaneously. A neutral zone can be set between humidification and dehumidification.

The humidity transmitter must have an output signal of 0...10 V DC, for example:

HRT, HRT250 or HRT350	Room humidity transmitters
HDT2200 or HDT3200	Duct transmitters

DI1, Start signal

Normal control will only be activated when this input is activated, closed. When the start signal is deactivated the controller will set the outputs to 0.

Maximum Limiting, RH Max

When running humidification with the main sensor in the room it is sometimes desirable to have some sort of maximum limiting on the humidity in the supply duct.

To create such a limiting function, place an on/off humidistat such as HMH in the supply air duct and wire it into the start signal circuit on DI1. The humidistat should be normally closed.

Opening of the contact when the humidity rises above the set maximum value will force the humidity output to 0.

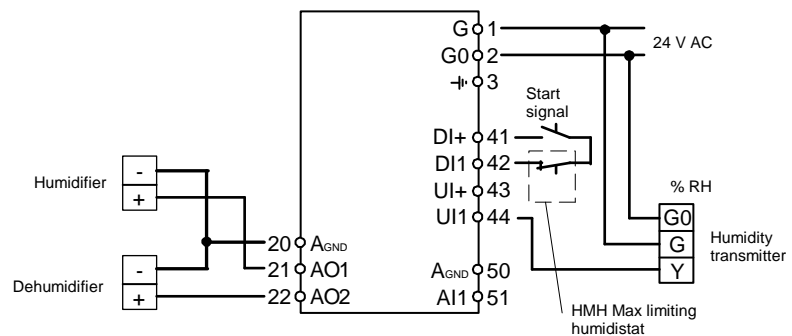

Control mode 4, Pressure control

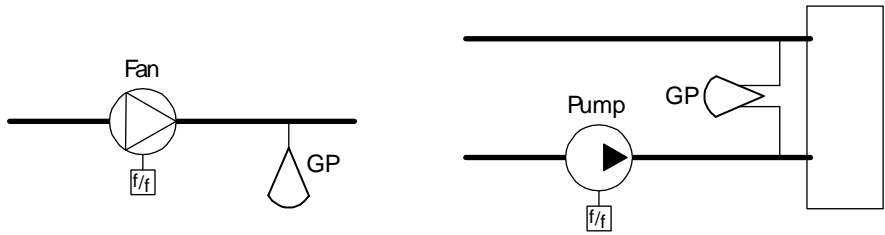

The output signal will increase when the pressure signal falls below the setpoint value.

The pressure transmitter must have an output signal of 0...10 V DC, for example:

DMD

DTL-series

DTK-series

TTK-series

Pressure ranges up to 500 kPa can be set.

Start signal

Normal control will only be activated when this input is activated, closed. When the start signal is deactivated the controller will set the output to 0.

Note: This input must always be wired since it controls the starting and stopping of normal control.

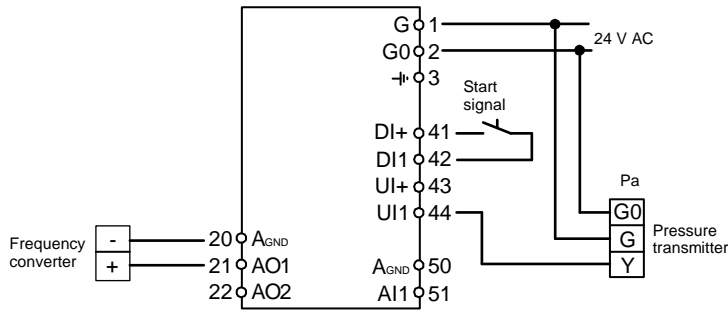

Control mode 5, Pressure control with outdoor temperature compensation of the pressure setpoint.

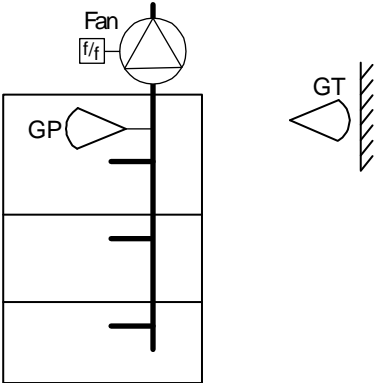

The output signal will increase when the pressure signal falls below the setpoint value.

The setpoint value follows a settable pressure-to-outdoor temperature relation.

The pressure transmitter must have an output signal of 0...10 V DC, for example:

DMD

DTL-series

DTK-series

TTK-series

Pressure ranges up to 500 kPa can be set.

DI1, Start signal

Normal control will only be activated when this input is activated, closed. When the start signal is deactivated the controller will set the output to 0.

Note: This input must always be wired since it controls the starting and stopping of normal control.

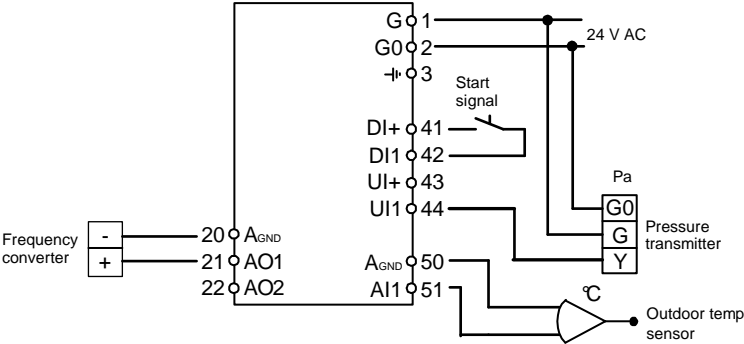

Chapter 6 Display and encoder

All setting and configuration is done using the display and encoder.

The menu information on the display is organised in a tree fashion. Using the encoder you can move between menus, set values etc.

In any of the configuration menus, a press on the encoder will activate change mode. You can then rotate the encoder button to move between choices or set values. A second pressing of the button will accept the choice.

The menu system is divided into two levels: The Basic level and the 10-second level which contains all the configuration menus.

The Basic level

The Basic level comprises three sets of menu displays, the Base Display, the I/O Displays and the Setpoint Display.

Base Display

This is an example of the Base Display, the display that is normally shown when there is no operator activity.



The upper line shows which control mode has been configured, in this case control mode 1, Temperature control. The bottom line shows the actual value of the main input parameter. There are bar-graphs showing the current output levels. In control mode 1 there are symbols showing how the outputs have been configured (Heating, Cooling, Damper or Change-over).

I/O

When the Base Display is shown, by twisting the knob counter clockwise until the text I/O is displayed and then clicking on it, you can gain access to a menu where you can look at the values and states of all inputs and outputs.

To exit this menu again, click on the knob and then twist the knob clockwise and you will be returned to the Base display.

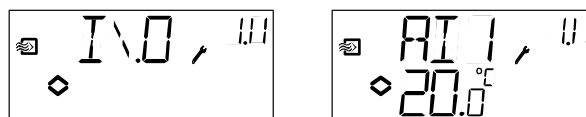

Setpoint

When in the Base Display, a press on the encoder button gives direct access to the Setpoint menu.

See chapter 7 Setpoint.



The 10-second level

This level is reached from the Base Display by depressing and holding the encoder button for 10 seconds. The 10-second level holds all the configuration menus. See chapter 8 Configuration.

Note: The controller must display the Base Display when pressing the encoder knob to reach the 10-second level.



Display symbols

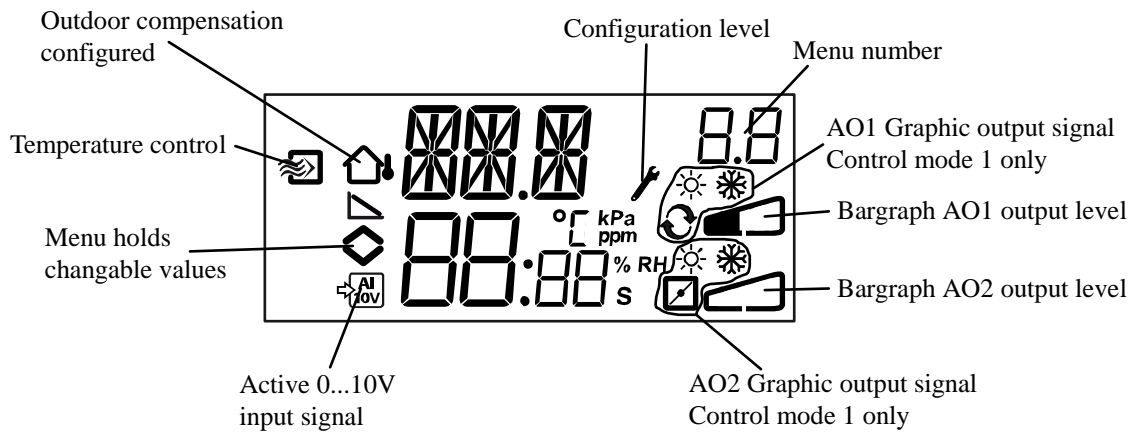

Chapter 7 Setpoint

The setpoint menu is normally accessed from the Base Display by a clicking on the encoder knob.

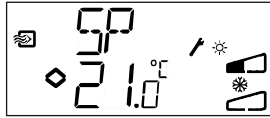

If you wish to change the displayed value, click on the knob again and the change indicators will start to flash to show that you are now in change mode. Twist the knob, clockwise to increase the value, counter-clockwise to decrease.

In applications with active input signals (control modes 2, 3, 4 and 5) the setpoint cannot be set higher than the value corresponding to 10 V DC input signal.

When the desired value is shown, click on the knob to acknowledge. To return to the Base display, twist the knob.

For configurations involving a single output signal the setpoint is the starting point for the output signal.

For configurations involving two diverging output signals with neutral zone (heating – cooling or humidification – dehumidification) the setpoint is placed in the middle of the neutral zone.

For configurations involving two outputs without neutral zone (heating – heating, cooling – cooling, heating – damper or cooling – damper) the setpoint value is the starting point for the first sequence (Y2)

Chapter 8 Configuration

All the configuration menus lie in the 10-seconds level. This level is accessed from the Base Display by pressing and holding the encoder button for 10 seconds.

There are numerous configuration menus covering all available options and combinations. In some cases, making a certain choice in one menu will mean that you will only see certain other menus. For example, the menu for setting the damper minimum limit is only shown if you have configured AO2 to be a damper control output.

Menus 1.0 – 5.0

In the first set of configuration menus you choose which of the five control modes you wish to run. The upper text row, the lower text row number and the first digit in the menu-number show which control mode is at hand.

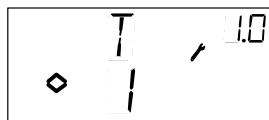

1. Temperature control

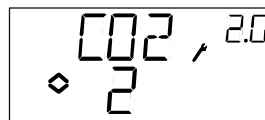

2. CO2-control

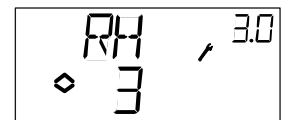

3. Humidity control

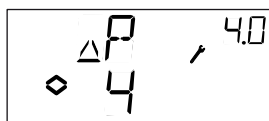

4. Pressure control

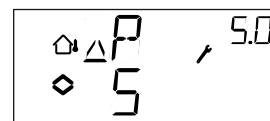

5. Pressure control with outdoor compensation

Menu X.1 Output signals (Control mode 1 only), Transmitter range (Control modes 2, 3, 4 and 5)

Control mode 1.

For temperature control there is a choice of 8 different output signal combinations. Select one fitting the application on hand.

AO1	/	AO2	Output symbol	Graphic symbol
1. Heating	/	-	\	☀
2. Cooling	/	-	/	❄
3. Heating	/	Cooling	\/	☀ ❄
4. Heating	/	Heating	\\	☀ ☀
5. Cooling	/	Cooling	//	❄ ❄
6. Heating	/	Damper	\/	☀ 🗡
7. Cooling	/	Damper	\/	❄ 🗡
8. Change-over	/	-		🔄

For each alternative the number representing it is shown along with a graphic symbolisation of the output signals and also a symbol next to the bar-graph for each output.

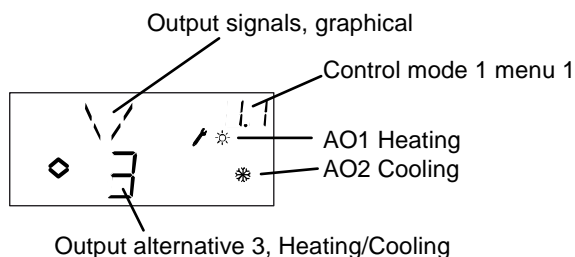

Example, Menu 1.1
Temperature control with output alternative 3 Heating/Cooling

Control modes 2, 3 4 and 5

For control modes using active 0...10 V DC transmitters you need to scale the input signal. For example, if you have a pressure transmitter that will give a 0...10 V output for a pressure range of 0 to 5000 Pa, set the value to 5000 Pa. Note that for pressure transmitters the pressure, depending on the range, may be given in Pa or kPa. Ranges up to 500 kPa can be set. Also, not all values between 0 and 500 kPa can be set since this would involve a great amount of twisting on the encoder. In the low ranges the values are close but become increasingly further between as the values go up.

For CO₂ transmitters the range is set in ppm and for humidity control in % RH.

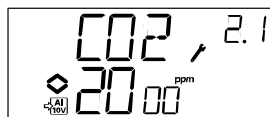

Example, Menu 2.1
CO₂-control with input signal 0...10 V for CO₂ value 0...2000 ppm.

Menus X.2 Neutral zone (Control mode 1 and 3)

In two control modes involving diverging output signals (heating – cooling or humidification – dehumidification) you can set a neutral zone between the outputs. The setpoint will be placed at the middle of the neutral zone.

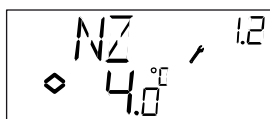

Menus X.3 P-band

Here you set the P-band (Proportional band) The P-band unit depends on the choice of control mode. The P-band is the control offset necessary to drive an output signal from 0 to 100%. In configurations involving two outputs the same P-band applies to both outputs.

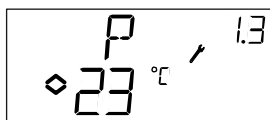

Menus X.4 I-time

Here you set the Integration time (Reset time). If the I-time is set to 0 the integration function is disabled and the controller will act as a P-controller.

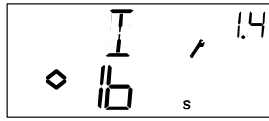

Menu 1.5 Damper minimum position (Control mode 1 only)

If you in menu 1.1 have configured output AO2 to be a damper, alternative 6 or 7, you can set a minimum value to the damper signal. The damper output will then not go lower than the set value during normal operation. On shut-down however the signal will go to zero and fully close the damper.



Menu 5.7 Start point for outdoor compensation (Control mode 5 only)

S.P is the outdoor temperature at which the setpoint compensation starts. At temperatures higher than S.P the normal setpoint value is maintained. When the outdoor temperature falls below S.P the pressure setpoint will change linearly on decreasing temperature to reach the pressure set by SPL in menu 5.8 below at an outdoor temperature of -20°C



Menu 5.8 Maximum compensation (Control mode 5 only)

SPL is the setpoint to be held at an outdoor temperature of -20°C. The setpoint shift starts when the outdoor temperature falls below the value set in S.P in menu 5.7 above and will change linearly with decreasing outdoor temperature reaching SPL when the outdoor temperature is -20°C. Note that SPL is not a setpoint shift value to be added to the normal setpoint value but the actual setpoint value at -20°C outdoor temperature.

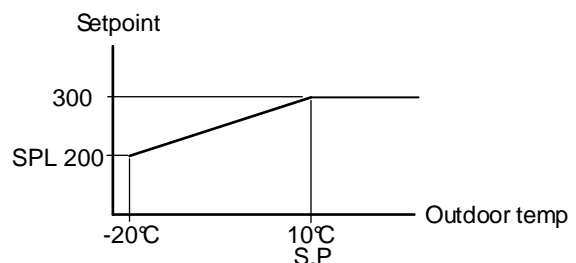

Example: With an ordinary setpoint of 300 Pa, a starting point S.P of +10°C and a SPL of 200 Pa at -20°C you get the following setpoint-to-outdoor temperature relation

Menus X.9 I/O

After the last configuration menu there is a menu where you can look at the actual values of all the inputs and outputs. This menu can also be accessed directly from the Base Display by twisting the encoder knob counter clockwise and then pressing. See chapter 6.

Menu OK

Last of the configuration level menus is the OK-menu. To leave the configuration level, go to this menu and press the encoder knob.



On exit from the configuration level you will be returned to the Basic level.

There is also a time-out function that will automatically exit the configuration level after 5 minutes of inaction.

Storage of settings

All configuration settings become valid as soon as they are entered by clicking the encoder knob. They are however not written to the flash memory until you exit the configuration level either via the OK menu or via the time-out function.

To exit the configuration level without saving the changes to flash memory, cut the supply voltage when still in the configuration level. All values will be kept as they were before you entered the configuration level.

Reset to factory setting

The OP5 can be reset to factory settings by configuring Humidity control (mode 3) and setting the P-band to 99. Then cut the power supply. When power is reapplied all configuration settings will be reset to factory setting.

Chapter 9 Index

1	
10 second level	17
A	
Analogue inputs	9
Analogue outputs	9
B	
Basic level	16
C	
Change-over	11
Configuration	19
Configuration level	17
Control modes	6
1, Temperature control	10
2, CO ₂ control	12
3, Humidity control	13
4, Pressure control	14
5, Pressure control with outdoor temperature compensation of the pressure setpoint	15
D	
Damper limiting	11, 21
Digital inputs	9
Display and encoder	16
E	
EMC	7
I	
Inputs and outputs	6, 9
Analogue inputs	9
Analogue outputs	9
Digital inputs	9
Universal inputs	9
Installation	8
I-time	21
L	
LVD	7
M	
Menu	
Configuration	19
I/O	16, 22
OK	22
Setpoint	16, 18
Mounting	5
R	
Reset time	See I-time
S	
Setpoint	18
Start signal	11, 12, 13, 14, 15
Supply voltage	8
T	
Technical data	7
Inputs	7
Outputs	7
U	
Universal inputs	9
V,W	
Wiring	8
Wiring diagram	
Control mode 1	11
Control mode 2	12
Control mode 3	13
Control mode 4	14
Control mode 5	15
Wiring diagram, general	8



AB Regin

Huvudkontor, Marknadsföring, Försäljning och Logistik

Box 116

Telefon: + 46 (0)31-720 02 00

E-mail: info@regin.se

428 22 Källered

Fax: + 46 (0)31-720 02 50

Websida: www.regin.se

Försäljningskontor Frankrike

Regin Control SARL

5 Rue Renault

FR-93500 Pantin, France

Telefon: +33 (0)1 41710034

Fax: +33 (0)1 41714646

Websida: www.regin.fr

Försäljningskontor Singapore

Regin Controls Asia Pacific Pte Ltd

66 Tannery Lane,

#03-04 Sindo Building, Singapore 347805

Telefon: + 65 6747 8233

Fax: + 65 6747 9233

E-mail: info@regin.com.sg

Websida: www.regin.com.sg

Försäljningskontor Hong Kong

Regin Controls Hong Kong Limited

2901 EW International Tower

120 Texaco Road, Tseun Wan,

NT, Hong Kong

Telefon: + 852 2407 0281

Websida: www.regin.com.hk