

LEISTER Examo Tensiometer

(according to DIN 51221 part 1)



Please read operating instructions carefully before use and keep for further reference.

APPLICATION

- **Tensiometer for peeling, shearing and tensile tests of geomembranes, geotextiles and films.**
(see DVS 2225 part II, DVS 2203 part II, BAM)

To determine the strength of a welding sample the test piece (according to DVS, DIN 53455 or ASTM) is fastened in to the tensiometer and stretched under constant speed until it tears.

Peak force (F_{Peak}) and tear force (F_{Tear}) as well as the corresponding elongation data are on the display at the end of the test. If the sample is stretched, the tensile force of the maximum yield stress is displayed.

| | | |
|---|----------|----------------------------|
| Standard values for test speeds: (DVS, DIN and ASTM) | PVC-P | 100 mm/min. (3.93 in/min.) |
| | PE-HD | 50 mm/min. (1.96 in/min.) |
| | PP, PVDF | 20 mm/min. (0.78 in/min.) |
| | PVC-U | 10 mm/min. (0.39 in/min.) |

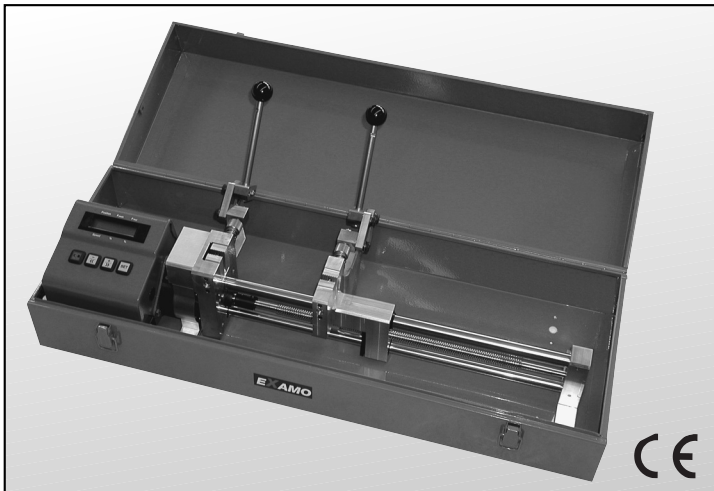



WARNING



Danger to life when opening the tool, as live components and connections are exposed. Unplug the tool before opening it.



CAUTION



The **voltage rating** stated on the tool must correspond to the mains voltage.



For personal protection on building sites we strongly recommend the tool be connected to a **RCCB** (Residual Current Circuit Breaker).



The tool must be earthed with a protective conductor.



Protect the tool from **damp and wet**.



Do not touch drive shaft and sliding carriage during operation.



Do not operate the sliding carriage when a welding sample is fastened in.

APPROVAL MARK



| Technical Data | | Examo 300F | Examo 300 | Examo 600F | Examo 600 |
|-----------------------------------|-----------------|-----------------|-----------------|-----------------|-----------------|
| Voltage* | V~ | 120, 230 | 120, 230 | 120, 230 | 120, 230 |
| Power consumption | W | 230 | 230 | 230 | 230 |
| Max. tensile load | N (lbf) | 4000 | 4000 | 4000 | 4000 |
| Temperatur range | °C | - 5 up to + 80 | – | - 5 up to + 80 | – |
| Load measure range | N (lbf) | 0 – 4000 | no power sensor | 0 – 4000 | no power sensor |
| Diviation indicator | % | < 3% FS at 20°C | – | < 3% FS at 20°C | – |
| Min. jaw spacing | mm (in) | 5 | 5 | 5 | 5 |
| Max. jaw spacing | mm (in) | 300 | 300 | 600 | 600 |
| Max. range | mm (in) | 300 | 300 | 600 | 600 |
| Testing speed | mm/min. (in/mm) | 10 – 300 | 10 – 300 | 10 – 300 | 10 – 300 |
| Max. sample thickness | mm (in) | 7 | 7 | 7 | 7 |
| Max. sample width | mm (in) | 40 | 40 | 40 | 40 |
| | | (60 optional) | (60 optional) | (60 optional) | (60 optional) |
| Memory-Card | | optional | not available | optional | not available |
| Weight | kg | 14 | 14 | 17.5 | 17.5 |
| Dimension of storage case (LxWxH) | mm | 750x270x190 | 750x270x190 | 1050x270x190 | 1050x270x190 |

* Mains voltage cannot be switched over

Readiness for working

- Open storage case
- Connect enclosed mains cable to **socket (1)**
- Connect the machine to the mains
- Pull out **clamping lever (9)** till it is locked
- Turn-on main **switch (2)**
 - Position of sliding carriage is not at **spacer (13)**
 - Press \llcorner , for *Initialize* appears on **display (4)**
 - Push key \llcorner , *Wait for Initialize* appears on **display (4)** and **sliding carriage (12)** moves to **spacer (13)**.
 - **Display (4)** shows standard mode (see page 11)
- Position of sliding carriage is not at **spacer (13)**
 - **Display (4)** shows standard mode (see page 11)

Test parameter

- Set the test parameters using the following keys:



Set Speed



Set Initial Length



with force sensor

Set Initial Tension



- Speed: Test speed in mm/min.
- Initial Length: Jaw spacing in mm, which is automatically adjusted by the equipment when pressing the key \llcorner or \gg .
The jaw spacing can be corrected at any time with the key \llcorner or \gg . The absolute position of the **sliding carriage (12)** (jaw spacing) appears on the **display (4)**.

with force sensor

- Initial Tension: Level of initial tension. When the set initial tension is achieved, the evaluation of the tensile test starts. If the initial tension is set to **0 N**, the test evaluation can be started by pressing the \blacktriangleright Start key
- Exit menu by pushing \llcorner key.

with force sensor

- When setting the initial length, the force display may show the value $\neq 0$. Reason: Influence of temperature on the equipment and/or force on the **clamping jaws (11)** which are close to the **housing of the drive motor and circuit board (15)**.
- When starting the test, the force values are reset to 0.

The memory card version contains additional menu options (see operation of memory card on page 5).

Fasten test piece

- Release tension **clamping jaws (11)** with the **clamping lever (9)**.
- Adjust **clamping jaws (11)** at the **adjusting screw (10)** to thickness of sample.
- Fix sample material with **clamping lever (9)**.
- If the sample width is less than 40 mm, it has to be attached horizontally in the middle of the jaws height.
- Do not operate the sliding carriage backwards when the sample is fastened in, overload fuse will be activated.



Shear test (DVS 2226-2)

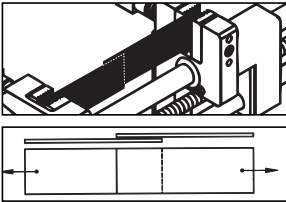

Peel test (DVS 2226-3)

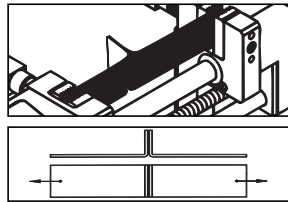

Tensile test (DVS 2203 Teil II)

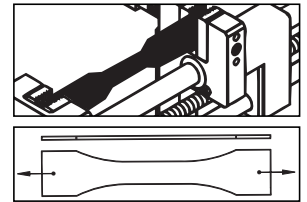

Start test procedure

- Press Start/Stop  key

with force sensor

- When the set initial tension value is achieved, the elongation and position values are reset to nought and the test evaluation starts (if the initial tension value is already set to **0 N**, the test evaluation starts immediately).

End test procedure

- In case the sample tears, push key  to stop **sliding carriage (12)**.
- If key  , is not pressed **sliding carriage (12)** stops automatically at the end.
- To interrupt or stop the tensile test, press  Start/Stop key.

with force sensor

- When sample shears, the **sliding carriage (12)** stops automatically.
- If the sample does not shear, the **sliding carriage (12)** stops at the end of the run.
- To interrupt or stop the tensile test, press  Start/Stop key. When interrupting the tensile test, the measuring values are not reset if the power sensor is under pressure the initial tension value (see F_{Peak} display). This guarantees that the existing test can be continued.

Reading test data

- Read the test values on the **display (4)**
- By pressing the key  , the **sliding carriage (12)** will return to its programmed starting position.

with force sensor

The position display reverts back to the absolute jaw spacing.

- By pressing the key  again, the test data are cancelled and a new tensile test can be started.

Remove test piece

- Relieve **clamping jaws (11)** with **locking lever (9)** and remove welding sample.
- The tool is ready for further testing.







Ready to transport

- Push **locking lever (9)** down until to the limit.
- Unplug tool from the mains.
- Unplug cable from **socket (1)** und put it into the storage case.
- Close the storage case.

Change of clamping jaws

- Flexible jaws
 - Fasten adjustment **screw (10)** against the **clamping jaw (11)**.
 - Unscrew the **cocking-lever shaft (22)** from **clamping jaw (11)** with a 8 mm spanner.
 - Remove **clamping jaw (11)**.
- Fixed clamping jaws
 - Unscrew **set screw (16)** with 4 mm hexagonal box spanner.
 - Pull off **clamping jaw (11)**.
- Assemble clamping jaws in reverse order.
 - Watch the alignment of **clamping jaws (11)**.

Memory Card (optional) for Tensiometer EXAMO 300F and 600F

- The **memory card** makes it possible to record the process values of **tensile load, elongation and test speed**. The evaluation is carried out with Software (which is not included) eg MS Excel or similar programmes.
- **Date and time**
 - When first starting up the equipment with integrated **memory card**, set the date and time using the keys   (press simultaneously). The **memory card** must not be in the **memory card drive (5)** during this procedure.
 - Set the values with the keys   and confirm with the  key. Date and time will now work independently of the mains and are backed up by a battery. We recommend checking this from time to time.
 - Exit menu by pushing  key.
- **Card formatting**
 - Insert new memory card (not included) into external recording unit (PCMCIA-Slot).
 - Formatting of memory card according to instructions of the external recording unit (not included).
- **Insert card**
 - Oper protecting cover.
 - Insert memory card into the **memory card drive (5)**.
 - Close the cover.
 - If the symbol ? appears on the right next to the speed display and the green LED display on the **memory card drive (5)** has lit up, the memory card is recognised.

• Select a specific file

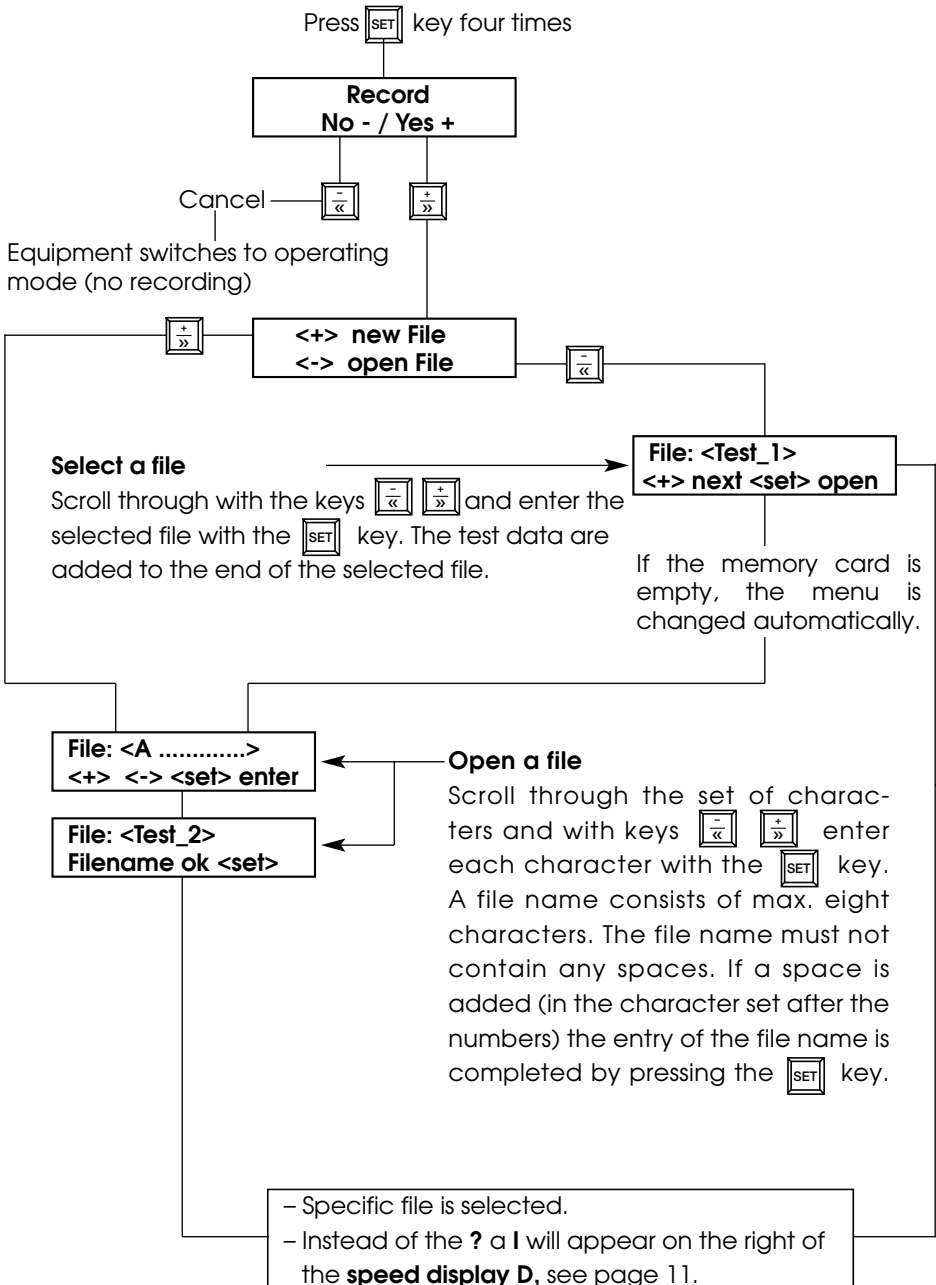



• **Recording of test data**

- The card is now ready for recording.
- Start a test by pressing the key , the symbol on the **display (4)** changes from **I** to **→**. The red light on the **memory card drive (5)** will flash.
- The values of **tensile load, speed and elongation** are now recorded until the sample shears and the tensile test is stopped or the end of the run is reached.
- A header with date and time is saved during/for each test (see evaluation of test data).

• **Further records**

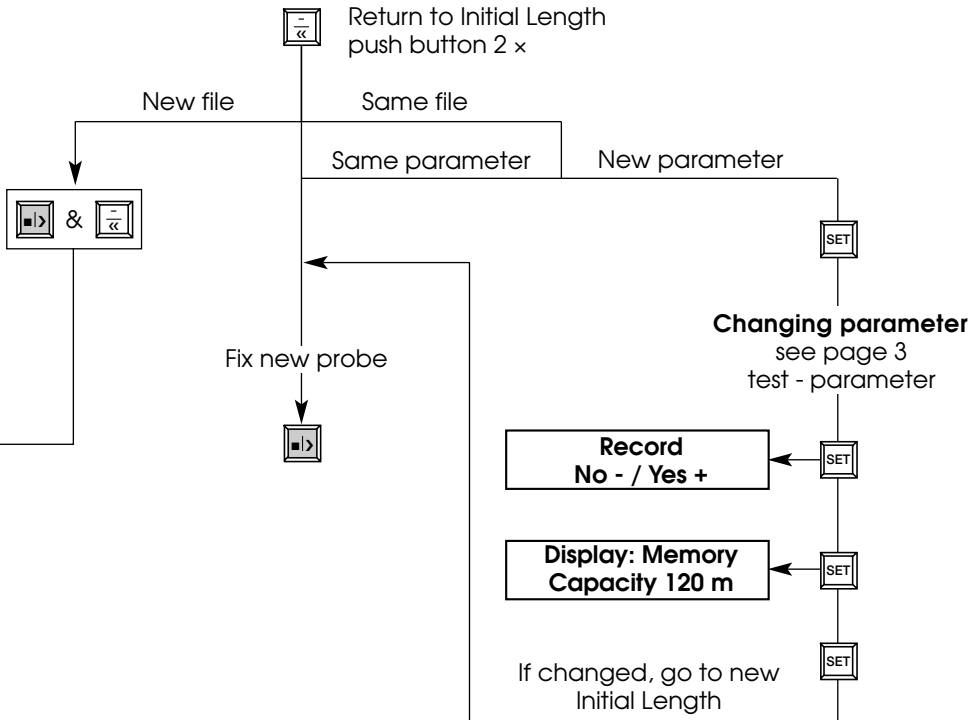
- Take off the probe



- If test records are not required, press the key  for **No** in the record menu **+ / Yes - / No**.

• **Remaining storage space on the card**

- The remaining memory capacity on the card is given in test length meters (foot).
- Query by pressing the  key five times.
- Display: *memory capacity 120 m (393 ft)*
(The memory capacity lasts for further 120 m (393 ft) test length).

Evaluation of test data using MS Excel (not included)

- Insert memory card into external data reading/recording equipment (PCMCIA slot, not included).
- Open MS Excel
- Open file
- Select disk drive (disc drive with memory card)
- File type: «all files»
- Select recorded file (*.txt) and open it.
- Excel recognises structured txt file.
- Text assistant (Step one to three)
- Step one: Mark the option «separate» and then «continue» in the field «original data type».
- Step two: In the field «separator/tag» mark the option «tabstop» and «space», then «proceed».
- Step three: In the field «dataformat of columns» mark the option «standard» and then «finish».
- The file will be displayed in this format:

| | | | |
|---------|------------|----------|----------|
| Date: | 14.05.2001 | | } header |
| Time: | 08:21 | | |
| Stretch | F_PV | Speed_PV | } data |
| (%) | (N) | (mm/min) | |
| 0 | 0 | 100 | |
| 1 | 3 | 100 | |

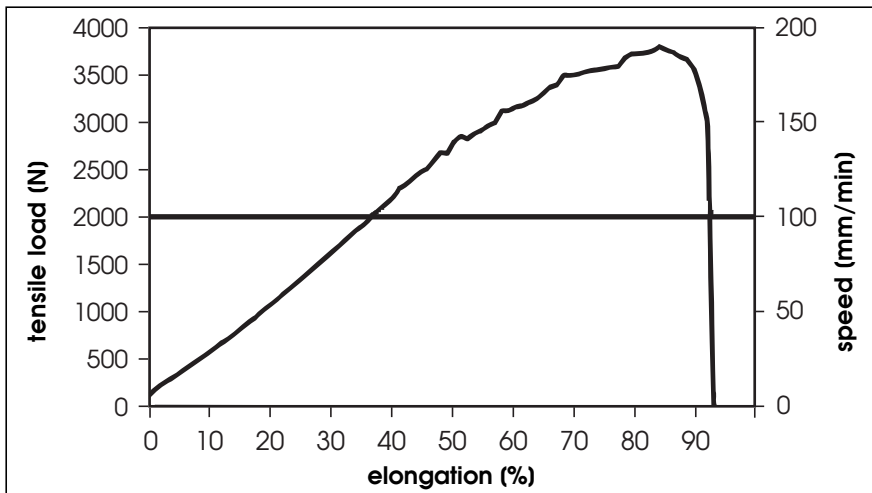

Create diagramm

- Select a test. Mark the columns including lowest line of the header (see list above, grey shaded fields).
- Click on «create diagramm» and create the diagramm with the help of the assistance (more detailed information is available from the Excel help facilities or from the Excel User Handbook (not included in this package).
- Possible illustration



Operating faults and preventative measures



• Blockage of carriage on return passage

- If the carriage return is obstructed, the overload safety device will be activated.
- The **trapezoidal thread nut (14)** is released from the **sliding carriage (12)**.
- The **trapezoidal thread nut (14)** moves to the **safety position for return passage (17)** of the **drive shaft (6)**.
- The machine has to be stopped with the key .
- In case machine is in modus «*Wait for Initialize*», operate **spacer (13)** manually.
- Start the machine with the key .
- Move the **trapezoidal thread nut (14)** to the **thread start for return passage (19)** by hand. The **trapezoidal thread nut (14)** is caught by the **drive shaft (6)** and moved in test direction.
- If at least one pitch of the screw thread on the **drive shaft (6)** is visible on the left hand side of the **trapezoidal thread nut (14)**, stop the machine with the key .
- Push the **sliding carriage (12)** by hand until it stops at the **trapezoidal thread nut (14)**.
- Switch off the machine with **main switch (2)** and switch it on again.
- Re-initialize the machine according to operating instructions on page 4.

• Overload safety device in test direction

- If the maximum allowable tensile load of 4000N is exceeded, the machine switches off automatically to prevent damages.
- Relieve probe by pushing the key .
- Remove sample (page 6).
- Fasten new sample and repeat test (Page 5 and 6).

• Overrunning the end of drive shaft in test direction

- If the end of the test run is not recognised, the **sliding carriage (12)** goes to the **safety position for test direction (18)**.
- Stop machine with  key.
- Start machine with  key.
- Bring **sliding carriage (12)** by hand to the **thread start for test direction (20)**.
- If at least one pitch of the screw thread on the **drive shaft (6)** is visible on the right hand side of the **sliding carriage (12)**, stop the machine with the  key.
- Switch off the machine with the **main switch (2)** and switch it on again.
- Re-initialize the machine according to operating instructions on page 4.

Description of tool

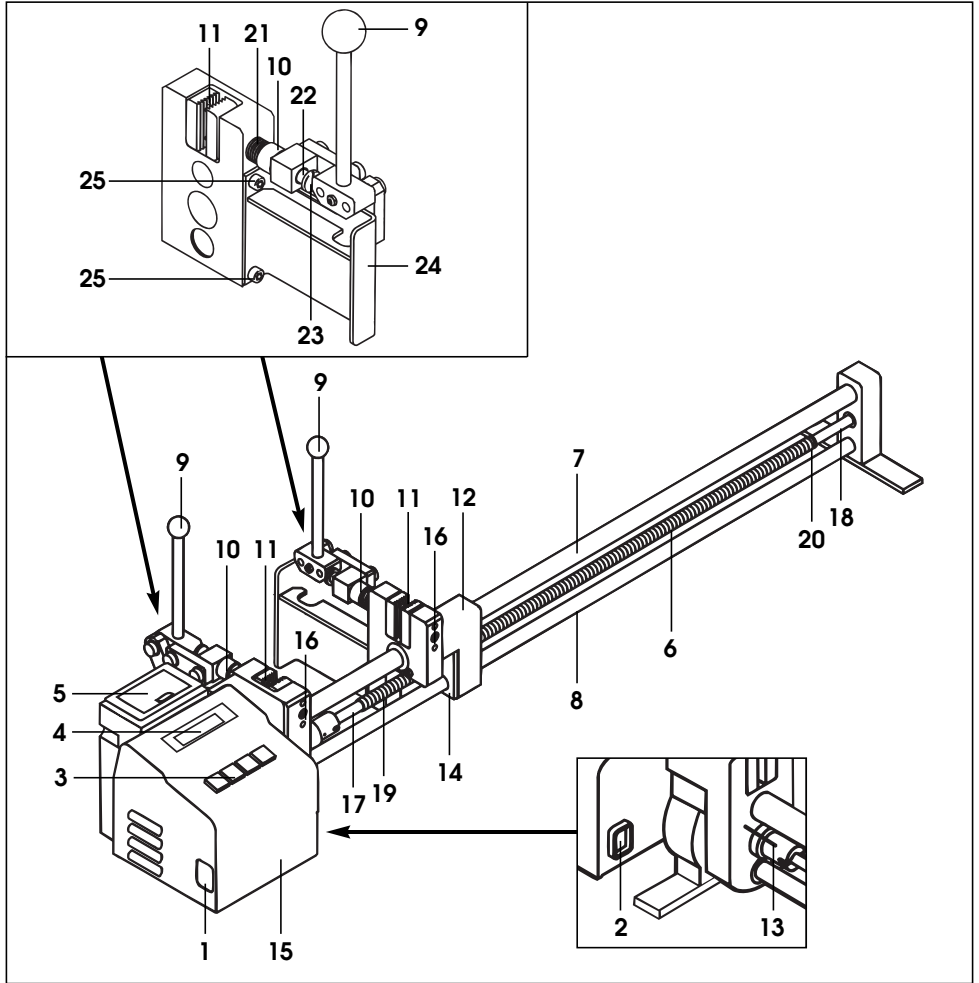

- | | | |
|---------------------------------|---|-------------------------------------|
| 1. Plug socket | 11. Clamping jaws | 18. Safety position for direction |
| 2. Main switch | 12. Sliding carriage | 19. Thread start for return passage |
| 3. Keyboard | 13. Spacer | 20. Thread start for test direction |
| 4. Display | 14. Trapezoidal thread nut | 21. Spring |
| 5. Memory card drive (optional) | 15. Housing for drive motor and electronics | 22. Cocking-lever shaft |
| 6. Drive shaft | 16. Set screw for fixing clamping jaw | 23. Flat head screw |
| 7. Upper guide bar | 17. Safety position for return passage | 24. Holder |
| 8. Lower guide bar | | 25. Set screw |
| 9. Clamping lever | | |
| 10. Adjustment screw | | |

Keyboard (3)

| | | | |
|-------------|------------------------|--------------------------|-------------|
| | | | |
| Start /Stop | Fast motion back/MINUS | Fast motion forward/PLUS | Select menu |

Display (4)

with force sensor

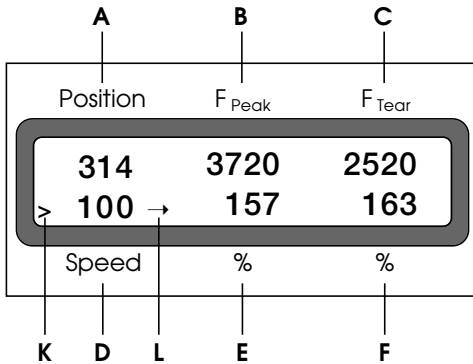

without force sensor

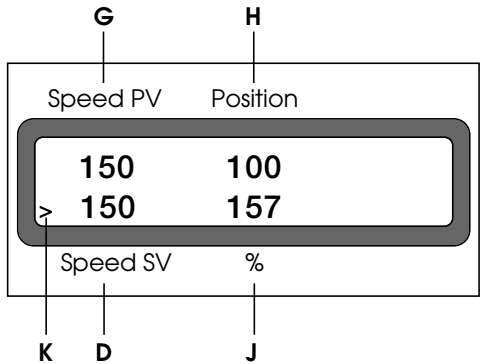

- A** On-state sledge position (see page 3) (mm)
When pushing keys or absolute sledge position (mm)
- B** Max. tensile load of test in progress (N) (lbs)
- C** Before shearing: actual tensile load (N) (lbs)
After shearing: tearing force (N) (lbs)
- D** Test speed set value (mm/min)
- E** Elongation at F_{Peak} (stops with F_{Peak})
- F** Elongation at shearing
- G** Test speed actual value (mm/min)
- H** Absolute sledge position (mm)
- J** Actual extension
- K** Status of machine
 - > testing
 - Stop
 - » Fast motion forward
 - « Fast motion backward
- L** Status of memory card
 - ? Memory-card in disc drive
 - | File selected
 - Recording

Memory card drive (5)

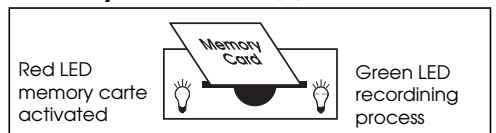

VERSIONS

Tensiometer Examo 300
Tensiometer Examo 300F
Tensiometer Examo 300F with memory card drive
Tensiometer Examo 600
Tensiometer Examo 600F
Tensiometer Examo 600F with memory card drive

MAINTENANCE

- Keep **drive shaft (6)** clean and grease after 40 hours of operation. When using under difficult environmental conditions, the intervals have to be reduced.
- Keep **guide bars (7) (8)** clean.
- Friction bearings as well as shaft bearing are maintenance free. Lubrication with grease or oil (with grease additives such as Zinc Sulphide, Molybdenum Sulphide and similar) is not allowed as this would affect the working life of the bearings.
- Damaged wiper devices on the **sliding carriage (12)** have to be replaced immediately.
- Check power supply cord and plug for any possible electrical or mechanical damages

SERVICE UND REPAIR

- The carbon brushes in the motor should be checked by your Service Centre after about 1000 hours of operation.
- Repairs have to be carried out by authorised **LEISTER Service Centres** only. They guarantee a specialized and reliable **repair service within 24 hours** using original LEISTER spare parts.

GUARANTEE AND LIABILITY

- Guarantee and liability are in accordance with the guarantee certificate as well as with the currently valid general business and sales conditions.
- LEISTER Process Technologies rejects any guarantee claims for tools which are not in their original condition. The tools must never be altered or changed.

Technical data and specifications are subject to change without prior notice.

Your authorised Service Centre is: