

Operating Instructions

TDR sensor for continuous level and interface measurement of liquids

VEGAFLEX 83

4 ... 20 mA/HART - two-wire



Document ID: 41834

VEGA

Contents

- 1 About this document**
 - 1.1 Function 4
 - 1.2 Target group 4
 - 1.3 Symbolism used 4
- 2 For your safety**
 - 2.1 Authorised personnel 5
 - 2.2 Appropriate use 5
 - 2.3 Warning about incorrect use 5
 - 2.4 General safety instructions 5
 - 2.5 CE conformity 5
 - 2.6 NAMUR recommendations 6
 - 2.7 Environmental instructions 6
- 3 Product description**
 - 3.1 Configuration 7
 - 3.2 Principle of operation 8
 - 3.3 Packaging, transport and storage 10
 - 3.4 Accessories and replacement parts 10
- 4 Mounting**
 - 4.1 General instructions 13
 - 4.2 Instructions for installation 13
- 5 Connecting to power supply**
 - 5.1 Preparing the connection 18
 - 5.2 Connecting 19
 - 5.3 Wiring plan, single chamber housing 20
 - 5.4 Wiring plan, double chamber housing 21
 - 5.5 Wiring plan, Ex-d-ia double chamber housing 23
 - 5.6 Wiring plan - version IP 66/IP 68, 1 bar 24
 - 5.7 Switch-on phase 24
- 6 Set up with the indicating and adjustment module**
 - 6.1 Insert indicating and adjustment module 25
 - 6.2 Adjustment system 26
 - 6.3 Parameter adjustment 27
 - 6.4 Saving the parameter adjustment data 43
- 7 Setup with PACTware**
 - 7.1 Connect the PC 45
 - 7.2 Parameter adjustment with PACTware 46
 - 7.3 Set up with the quick setup 47
 - 7.4 Saving the parameter adjustment data 51
- 8 Set up with other systems**
 - 8.1 DD adjustment programs 52
 - 8.2 Communicator 375, 475 52

9 Diagnostics and service

9.1 Maintenance 53
 9.2 Diagnosis memory 53
 9.3 Status messages..... 54
 9.4 Rectify faults..... 57
 9.5 Exchanging the electronics module..... 60
 9.6 Software update 61
 9.7 How to proceed in case of repair 61

10 Dismounting

10.1 Dismounting steps..... 62
 10.2 Disposal 62

11 Supplement

11.1 Technical data 63
 11.2 Dimensions 72



Safety instructions for Ex areas

Please note the Ex-specific safety information for installation and operation in Ex areas. These safety instructions are part of the operating instructions manual and come with the Ex-approved instruments.

Editing status: 2012-07-26

1 About this document

1.1 Function

This operating instructions manual provides all the information you need for mounting, connection and setup as well as important instructions for maintenance and fault rectification. Please read this information before putting the instrument into operation and keep this manual accessible in the immediate vicinity of the device.

1.2 Target group

This operating instructions manual is directed to trained qualified personnel. The contents of this manual should be made available to these personnel and put into practice by them.

1.3 Symbolism used



Information, tip, note

This symbol indicates helpful additional information.



Caution: If this warning is ignored, faults or malfunctions can result.

Warning: If this warning is ignored, injury to persons and/or serious damage to the instrument can result.

Danger: If this warning is ignored, serious injury to persons and/or destruction of the instrument can result.



Ex applications

This symbol indicates special instructions for Ex applications.



List

The dot set in front indicates a list with no implied sequence.



Action

This arrow indicates a single action.



Sequence

Numbers set in front indicate successive steps in a procedure.



Battery disposal

This symbol indicates special information about the disposal of batteries and accumulators.

2 For your safety

2.1 Authorised personnel

All operations described in this operating instructions manual must be carried out only by trained specialist personnel authorised by the plant operator.

During work on and with the device the required personal protective equipment must always be worn.

2.2 Appropriate use

VEGAFLEX 83 is a sensor for continuous level measurement.

You can find detailed information on the application range in chapter "*Product description*".

Operational reliability is ensured only if the instrument is properly used according to the specifications in the operating instructions manual as well as possible supplementary instructions.

2.3 Warning about incorrect use

Inappropriate or incorrect use of the instrument can give rise to application-specific hazards, e.g. vessel overflow or damage to system components through incorrect mounting or adjustment.

2.4 General safety instructions

This is a state-of-the-art instrument complying with all prevailing regulations and guidelines. The instrument must only be operated in a technically flawless and reliable condition. The operator is responsible for the trouble-free operation of the instrument.

During the entire duration of use, the user is obliged to determine the compliance of the necessary occupational safety measures with the current valid rules and regulations and also take note of new regulations.

The safety instructions in this operating instructions manual, the national installation standards as well as the valid safety regulations and accident prevention rules must be observed by the user.

For safety and warranty reasons, any invasive work on the device beyond that described in the operating instructions manual may be carried out only by personnel authorised by the manufacturer. Arbitrary conversions or modifications are explicitly forbidden.

The safety approval markings and safety tips on the device must also be observed.

2.5 CE conformity

The device fulfills the legal requirements of the applicable EC guidelines. By affixing the CE marking, we confirm successful testing of the product.

You can find the conformity certificate in the download section of our homepage.

Only with Ex-d-ia version

The instrument is designed for use in an industrial environment. Nevertheless, electromagnetic interference from electrical conductors and radiated emissions must be taken into account, as is usual with a class A instrument according to EN 61326-1. If the instrument is used in a different environment, its electromagnetic compatibility with other devices must be ensured by suitable measures.

2.6 NAMUR recommendations

NAMUR is the automation technology user association in the process industry in Germany. The published NAMUR recommendations are accepted as the standard in field instrumentation.

The device fulfills the requirements of the following NAMUR recommendations:

- NE 21 – Electromagnetic compatibility of equipment
- NE 43 – Signal level for malfunction information from measuring transducers
- NE 53 – Compatibility of field devices and indicating/adjustment components
- NE 107 - Self-monitoring and diagnosis of field devices

For further information see www.namur.de.

2.7 Environmental instructions

Protection of the environment is one of our most important duties. That is why we have introduced an environment management system with the goal of continuously improving company environmental protection. The environment management system is certified according to DIN EN ISO 14001.

Please help us fulfil this obligation by observing the environmental instructions in this manual:

- Chapter "*Packaging, transport and storage*"
- Chapter "*Disposal*"

3 Product description

3.1 Configuration

Type label

The type label contains the most important data for identification and use of the instrument:

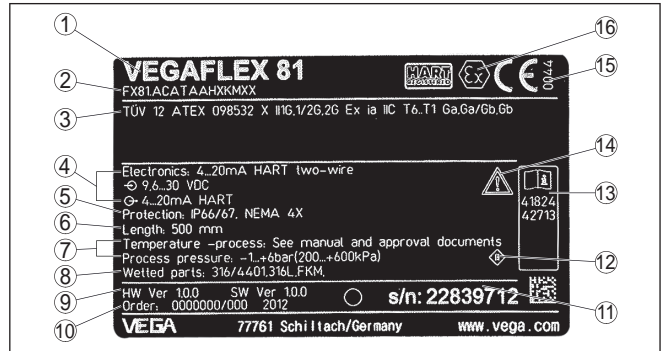

Fig. 1: Layout of the type label (example)

- 1 Instrument type
- 2 Product code
- 3 Approvals
- 4 Power supply and signal output, electronics
- 5 Protection rating
- 6 Probe length
- 7 Process and ambient temperature, process pressure
- 8 Material, wetted parts
- 9 Hardware and software version
- 10 Order number
- 11 Serial number of the instrument
- 12 Symbol of the device protection class
- 13 ID numbers, instrument documentation
- 14 Note to observe the instrument documentation
- 15 Notified authority for CE marking
- 16 Approval directive

Serial number

With the serial number of the instrument on the type label you have access to the following data on our homepage:

- Article number of the instrument (HTML)
- Delivery date (HTML)
- Order-specific instrument features (HTML)
- Operating instructions at the time of shipment (PDF)
- Order-specific sensor data for an electronics exchange (XML)
- Test certificate "Measuring Accuracy" (PDF)

For this purpose, move to www.vega.com and "VEGA Tools".

Scope of this operating instructions manual

This operating instructions manual applies to the following instrument versions:

- Hardware from 1.0.0
- Software from 1.0.0

Versions	<p>The instrument and the electronics version can be determined via the product code on the type label as well as on the electronics.</p> <ul style="list-style-type: none"> ● Standard electronics: Type FX80H.-
Scope of delivery	<p>The scope of delivery encompasses:</p> <ul style="list-style-type: none"> ● Sensor ● Documentation <ul style="list-style-type: none"> – this operating instructions manual – Test certificate measuring accuracy (optional) – Operating instructions manual "<i>Indicating and adjustment module</i>" (optional) – Supplementary instructions "<i>GSM/GPRS radio module</i>" (optional) – Supplementary instructions manual "<i>Heating for indicating and adjustment module</i>" (optional) – Supplementary instructions manual "<i>Plug connector for continuously measuring sensors</i>" (optional) – Ex-specific "<i>Safety instructions</i>" (with Ex versions) – CE declarations of conformity – if necessary, further certificates

3.2 Principle of operation

Application area	<p>The VEGAFLEX 83 is a level sensor with coated cable or rod probe for continuous level or interface measurement, particularly suitable for applications in the chemical industry.</p>
Functional principle - level measurement	<p>High frequency microwave pulses are guided along a steel rope or a rod. Upon reaching the product surface, the microwave pulses are reflected. The running time is evaluated by the instrument and outputted as level.</p>
Functional principle - interface measurement	<p>High frequency microwave impulses are guided along a steel cable or rod. When reaching the product surface, a part of the microwave impulses is reflected. The other part passes the upper product and is reflected a second time by the interface. The running times to the two product layers are processed by the instrument.</p>

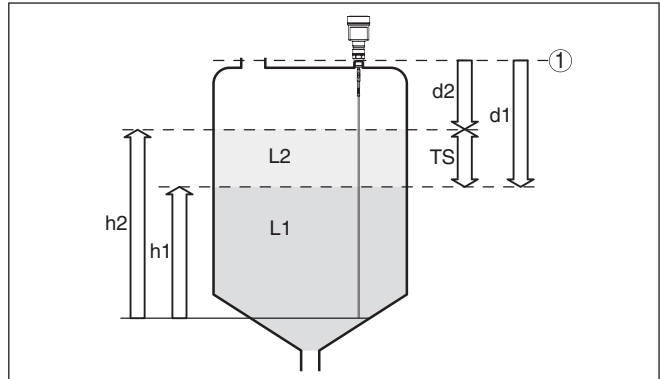

Fig. 2: Interface measurement

- 1 Sensor reference plane (seal surface of the process fitting)
- d1 Distance to the interface (HART value 1)
- d2 Distance to the level (HART value 3)
- TS Thickness of the upper medium ($d1 - d2$)
- h1 Height - Interface
- h2 Height - Level
- L1 Lower medium
- L2 Upper medium

Prerequisites for interface measurement

Upper medium (L2)

- The upper medium must not be conductive
- The dielectric constant of the upper medium must be known (input required). Min. dielectric constant: rod version 1.6. You can find a list with the dielectric constants on our home page: www.vega.com
- The composition of the upper medium must be stable, no varying products or mixtures
- The upper medium must be homogeneous, no stratifications within the medium
- Min. thickness of the upper medium 50 mm (1.97 in)
- Clear separation from the lower medium, no emulsion phase, no mull layer
- If possible, no foam on the surface

Lower medium (L1)

- The dielectric figure must be 10 higher than the dielectric constant of the upper medium, preferably electrically conductive. Example: upper medium dielectric constant 2, lower medium at least dielectric constant 12.

Output signal

The instrument is always preset to the application "Level measurement".

For the interface measurement, you can select the requested output signal with the setup.

3.3 Packaging, transport and storage

Packaging

Your instrument was protected by packaging during transport. Its capacity to handle normal loads during transport is assured by a test according to DIN EN 24180.

The packaging of standard instruments consists of environment-friendly, recyclable cardboard. For special versions, PE foam or PE foil is also used. Dispose of the packaging material via specialised recycling companies.

Transport

Transport must be carried out under consideration of the notes on the transport packaging. Nonobservance of these instructions can cause damage to the device.

Transport inspection

The delivery must be checked for completeness and possible transit damage immediately at receipt. Ascertained transit damage or concealed defects must be appropriately dealt with.

Storage

Up to the time of installation, the packages must be left closed and stored according to the orientation and storage markings on the outside.

Unless otherwise indicated, the packages must be stored only under the following conditions:

- Not in the open
- Dry and dust free
- Not exposed to corrosive media
- Protected against solar radiation
- Avoiding mechanical shock and vibration

Storage and transport temperature

- Storage and transport temperature see chapter "*Supplement - Technical data - Ambient conditions*"
- Relative humidity 20 ... 85 %

3.4 Accessories and replacement parts

Indicating and adjustment module

The indicating and adjustment module PLICSCOM is used for measured value indication, adjustment and diagnosis. It can be inserted into the sensor and removed at any time.

You can find further information in the operating instructions "*Indicating and adjustment module PLICSCOM*" (Document-ID 27835).

Interface adapter

The interface adapter VEGACONNECT enables the connection of communication-capable instruments to the USB interface of a PC. For parameter adjustment of these instruments, an adjustment software such as PACTware with VEGA-DTM is required.

You can find further information in the operating instructions "*Interface adapter VEGACONNECT*" (Document-ID 32628).

External indicating and adjustment unit

VEGADIS 61 is an external indicating and adjustment unit for sensors with single chamber housing and Ex-d double chamber housing.

It is suitable for measured value indication and adjustment of plics® sensors and is connected to the sensor with a four-wire standard cable up to 50 m long.

You can find further information in the operating instructions "VEGADIS 61" (Document-ID 27720).

External indicating and adjustment unit with HART protocol

VEGADIS 62 is suitable for measured value indication and adjustment of sensors with HART protocol. It is looped into the 4 ... 20 mA/HART signal cable.

You can find further information in the operating instructions "VEGADIS 62" (Document-ID 36469).

External radio unit

The PLICSMOBILE T61 is an external GSM/GPRS radio unit for transmission of measured values and for remote parameter adjustment of plics® sensors. The adjustment is carried out via PACTware/DTM by using the integrated USB connection.

You can find further information in the supplementary instructions "PLICSMOBILE T61" (Document-ID 36849).

Protective cover

The protective cover protects the sensor housing against soiling and intense heat from solar radiation.

You will find additional information in the supplementary instructions manual "Protective cover" (Document-ID 34296).

Flanges

Screwed flanges are available in different versions according to the following standards: DIN 2501, EN 1092-1, ANSI B 16.5, JIS B 2210-1984, GOST 12821-80.

You can find additional information in the supplementary instructions manual "Flanges according to DIN-EN-ASME-JIS" (Document-ID 31088).

Electronics module

The electronics module VEGAFLEX series 80 is a replacement part for TDR sensors of VEGAFLEX series 80. There is a different version available for each type of signal output.

You can find further information in the operating instructions manual "Electronics module VEGAFLEX series 80".

Indicating and adjustment module with heating

The indicating and adjustment module can be optionally replaced by an indicating and adjustment module with heating function.

You can hence use the indicating and adjustment module in a temperature range of -40 ... 70 °C.

You can find further information in the operating instructions "Indicating and adjustment module with heating" (Document-ID 31708).

Rod extension

If you are using an instrument with rod version, you can extend the rod probe individually with rod extensions of different lengths.

The following lengths are available:

- 100 mm
- 200 mm
- 500 mm

- 1000 mm

You can find further information in the operating instructions manual "*Rod extension VEGAFLEX series 80*".

Spacer

If you mount the VEGAFLEX 83 in a bypass tube or standpipe, you have to avoid contact to the bypass tube by using a spacer at the probe end.

You can find further information in the operating instructions manual "*Bypass tube VEGAPASS 81*".

4 Mounting

4.1 General instructions

Screwing in

With instruments with threaded process fitting, suitable tools must be applied for tightening the hexagon.



Warning:

The housing must not be used to screw the instrument in! Applying tightening force can damage internal parts of the housing.

Moisture

Use the recommended cables (see chapter "*Connecting to power supply*") and tighten the cable gland.

You can give your instrument additional protection against moisture penetration by leading the connection cable downward in front of the cable entry. Rain and condensation water can thus drain off. This applies mainly to outdoor mounting as well as installation in areas where high humidity is expected (e.g. through cleaning processes) or on cooled or heated vessels.

Protective caps

In the case of instrument housings with self-sealing NPT threads, it is not possible to have the cable entries screwed in at the factory. The openings for the cable glands are therefore covered with red protective caps as transport protection.

Prior to setup you have to replace these protective caps with approved cable glands or close the openings with suitable blind plugs.

The suitable cable glands and blind plugs come with the instrument.

Suitability for the process conditions

Make sure that all parts of the instrument exposed to the process, in particular the active measuring component, process seal and process fitting, are suitable for the existing process conditions. These include above all the process pressure, process temperature as well as the chemical properties of the medium.

You can find the specifications in chapter "*Technical data*" and on the type label.

4.2 Instructions for installation

Installation position

Mount VEGAFLEX 83 in such a way that the distance to vessel installations or to the vessel wall is at least 300 mm (12 in). In non-metallic vessels, the distance to the vessel wall should be at least 500 mm (19.7 in).

During operation, the probe must not touch any installations or the vessel wall. If necessary, fasten the probe end.

In vessels with conical bottom it can be advantageous to mount the sensor in the center of the vessel, as measurement is then nearly possible down to the lowest point of the bottom. Keep in mind that measurement down to the tip of the probe is probably not possible. The exact value of the min. distance (lower blocking distance) is stated in chapter "*Technical data*".

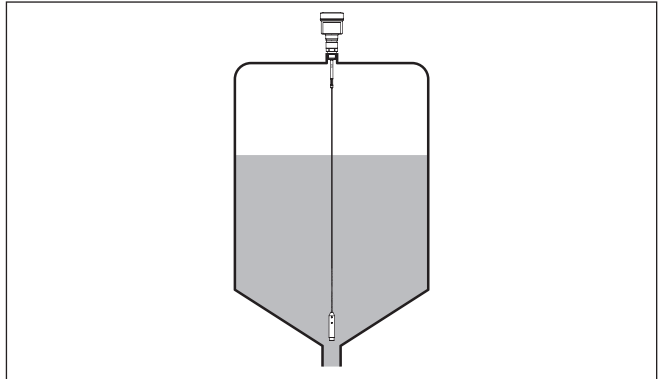

Fig. 3: Vessel with conical bottom

Type of vessel

Plastic vessel/Glass vessel

The guided microwave principle requires a metal surface on the process fitting. Therefore use in plastic vessels etc. an instrument version with flange (from DN 50) or place a metal sheet ($\varnothing > 200$ mm/8 in) beneath the process fitting when screwing it in.

Make sure that the plate has direct contact with the process fitting.

When installing rod or cable probes in vessels without metal walls, e.g. in plastic vessels, the measured value can be influenced by strong electromagnetic fields (emitted interference according to EN 61326: class A). In this case, use a probe with coaxial version.

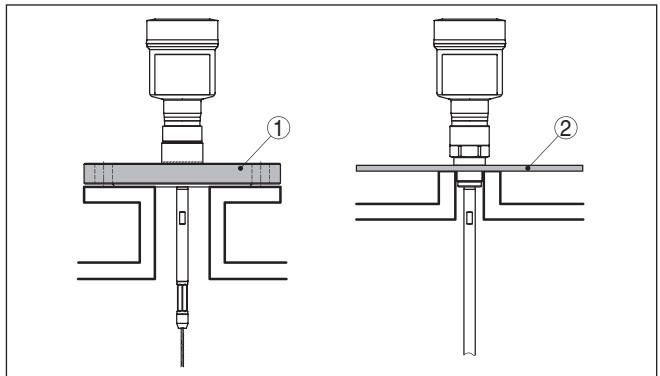

Fig. 4: Installation in plastic silo

- 1 Flange
- 2 Metal sheet

Socket

If possible, avoid sockets. Mount the sensor flush with the vessel top. If this is not possible, use short sockets with small diameter.

Higher sockets or sockets with a bigger diameter can generally be used. They simply increase the upper blocking distance. Check if this is relevant for your measurement.

In such cases, always carry out a false signal suppression after installation. You can find further information under "Setup procedure".

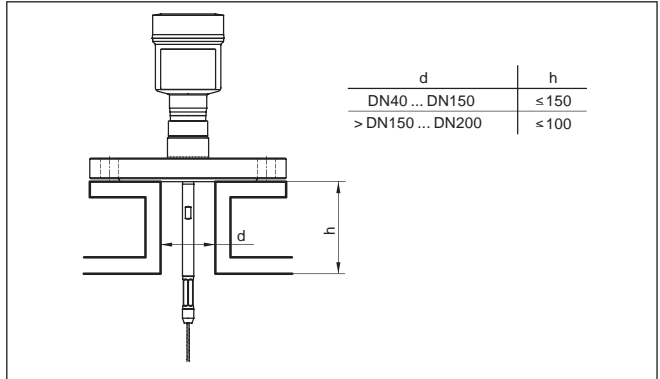

Fig. 5: Mounting socket

When welding the socket, make sure that the socket is flush to the vessel top.

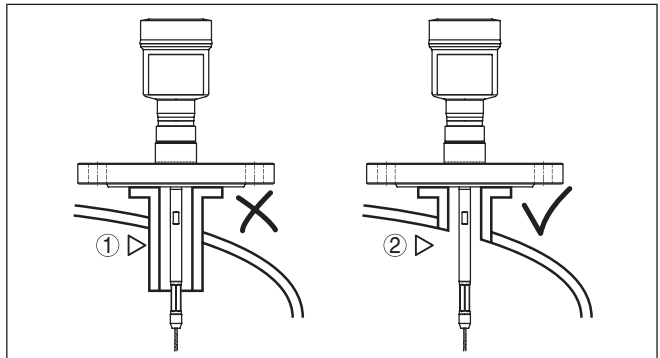

Fig. 6: Socket must be installed flush

- 1 Unfavourable installation
- 2 Socket flush - optimum installation

Welding work

Before beginning the welding work, remove the electronics module from the sensor. By doing this, you avoid damage to the electronics through inductive coupling.

Inflowing medium

Do not mount the instruments in or above the filling stream. Make sure that you detect the product surface, not the inflowing product.

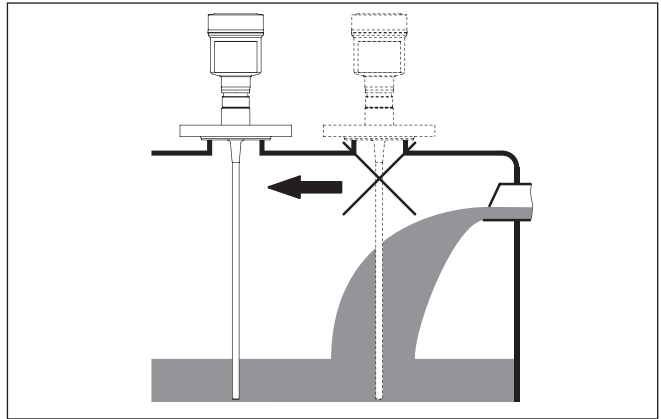

Fig. 7: Mounting of the sensor with inflowing medium

Measuring range

The reference plane for the measuring range of the sensors is the sealing surface of the thread or flange.

Keep in mind that a min. distance must be maintained below the reference plane and possibly also at the end of the probe - measurement in these areas is not possible (dead band). The length of the cable can be used all the way to the end only when measuring conductive products. These blocking distances for different mediums are listed in chapter "Technical data". Keep in mind for the adjustment that the default setting for the measuring range refers to water.

Pressure

The process fitting must be sealed if there is gauge or low pressure in the vessel. Before use, check if the seal material is resistant against the measured product and the process temperature.

The max. permissible pressure is specified in chapter "Technical data" or on the type label of the sensor.

Standpipes or bypass tubes

Standpipes or bypass tubes are normally metal tubes with a diameter of 30 ... 200 mm (1.18 ... 7.87 in). In measurement technology such a tube corresponds to a coax probe. It does not matter if the standpipe is perforated or slotted for better mixing. Lateral inlets with bypass tubes also do not influence the measurement.

Microwaves can penetrate many plastics. For process technical reasons, plastic standpipes are problematic. If durability is no problem, then we recommend the use of metal standpipes.

When the VEGAFLEX 83 is used in standpipes or bypass tubes, contact with the tube wall must be avoided. We recommend for this purpose a cable probe with centering weight.

Generally a spacer at the probe end is sufficient for rod probes to avoid contact to the tube wall. Depending on the tube diameter or tube length, spacers can be also mounted in the centre of the tube. With cable probes it is also possible to strain the cable.

Keep in mind that buildup can form on the spacers. Strong buildup can influence the measurement.

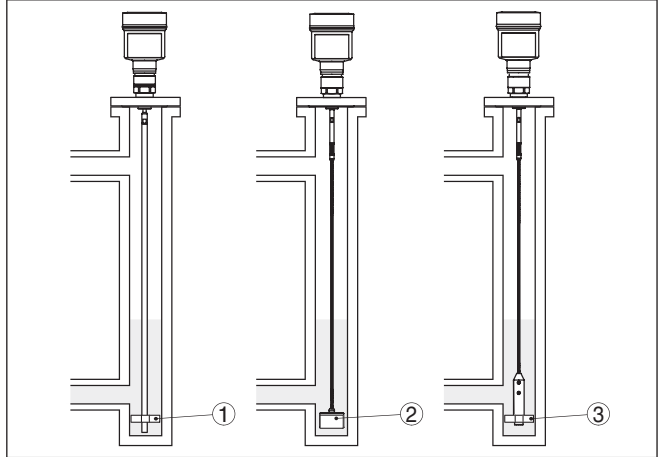

Fig. 8: Position of the spacer or centering weight

- 1 Rod probe with spacer (PEEK)
- 2 Cable probe with centering weight
- 3 Spacer (PEEK) on the gravity weight of a cable probe



Note:

Measurement in a standpipe is not recommended for extremely adhesive products.

Instructions for the measurement:

- The 100 % point should not be above the upper tube connection to the vessel
- The 0 % point should not be below the lower tube connection to the vessel
- A false signal suppression with integrated sensor is generally recommended to reach the maximum possible accuracy

Torque with PTFE plated flanges

To compensate the normal bias voltage loss due to the seal materials, you have to use also disc springs in addition to the flange screws for fastening PTFE plated flanges.

The flange screws of VEGAFLEX 83 must always be tightened with a torque of approx. 60 Nm (44 lbf ft) so that the PTFE washer seals reliably.

5 Connecting to power supply

5.1 Preparing the connection

Safety instructions

Always keep in mind the following safety instructions:

- Connect only in the complete absence of line voltage
- If overvoltage surges are expected, overvoltage arresters should be installed

Voltage supply

Power supply and current signal are carried on the same two-wire cable. The voltage supply range can differ depending on the instrument version.

The data for power supply are specified in chapter "*Technical data*".

Provide a reliable separation between the supply circuit and the mains circuits according to DIN VDE 0106 part 101.

Keep in mind the following additional factors that influence the operating voltage:

- Output voltage of the power supply unit can be lower under nominal load (with a sensor current of 20.5 mA or 22 mA in case of fault message)
- Influence of additional instruments in the circuit (see load values in chapter "*Technical data*")

Connection to signal conditioning instruments

The signal conditioning instruments VEGAMET and VEGASCAN have digital sensor recognition. When connecting VEGAFLEX 83, an up-to-date version of the signal conditioning instrument software is required. For a software update go to "www.vega.com/downloads" and "*Software*".

Connection cable

The instrument is connected with standard two-wire cable without screen. If electromagnetic interference is expected which is above the test values of EN 61326-1 for industrial areas, screened cable should be used.

For instruments with housing and cable gland, use cable with round cross-section. A cable outer diameter of 5 ... 9 mm (0.2 ... 0.35 in) ensures the seal effect of the cable gland. If you are using cable with a different diameter, exchange the seal or use a suitable cable gland.

We generally recommend the use of screened cable for HART multi-drop mode.

Cable gland ½ NPT

With plastic housing, the NPT cable gland or the Conduit steel tube must be screwed without grease into the threaded insert.

Max. torque for all housings see chapter "*Technical data*"

Cable screening and grounding

If screened cable is necessary, connect the cable screen on both ends to ground potential. In the sensor, the screen must be connected directly to the internal ground terminal. The ground terminal on the outside of the housing must be connected to the potential equalisation (low impedance).

If potential equalisation currents are expected, the connection on the processing side must be made via a ceramic capacitor (e. g. 1 nF, 1500 V). The low frequency potential equalisation currents are thus suppressed, but the protective effect against high frequency interference signals remains.



Warning:

Significant potential differences exist inside galvanization plants as well as on vessels with cathodic corrosion protection. Considerable equalisation currents can flow over the cable screen if the screen is grounded on both ends.

To avoid this in such applications, the cable screen must be connected to ground potential only at one end (in the switching cabinet). The cable screen must **not** be connected to the internal ground terminal in the sensor and the outer ground terminal on the housing must **not** be connected to the potential equalisation!



Information:

The metal parts of the instrument (process fitting, transmitter, concentric tube, etc.) are conductively connected with the inner and outer ground terminal on the housing. This connection exists either directly via connecting metallic parts or, in case of instruments with external electronics, via the screen of the special connection cable.

You can find specifications on the potential connections inside the instrument in chapter "*Technical data*".

5.2 Connecting

Connection technology

The voltage supply and signal output are connected via the spring-loaded terminals in the housing.

The connection to the indicating and adjustment module or to the interface adapter is carried out via contact pins in the housing.



Information:

The terminal block is pluggable and can be removed from the electronics. To do this, lift the terminal block with a small screwdriver and pull it out. When inserting the terminal block again, you should hear it snap in.

Connection procedure

Proceed as follows:

1. Unscrew the housing cover
2. If an indicating and adjustment module is installed, remove it by turning it slightly to the left.
3. Loosen compression nut of the cable entry
4. Remove approx. 10 cm (4 in) of the cable mantle, strip approx. 1 cm (0.4 in) of insulation from the ends of the individual wires
5. Insert the cable into the sensor through the cable entry

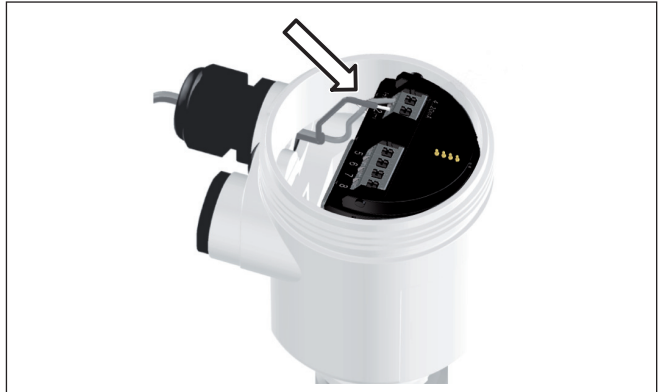

Fig. 9: Connection steps 5 and 6

6. Insert the wire ends into the terminals according to the wiring plan



Information:

Solid cores as well as flexible cores with cable end sleeves are inserted directly into the terminal openings. In case of flexible cores without end sleeves, press the terminal head with a small screwdriver; the terminal opening is freed. When the screwdriver is released, the terminal closes again.

You can find further information to the max. wire cross-section under "*Technical data/Electromechanical data*"

7. Check the hold of the wires in the terminals by lightly pulling on them
8. Connect the screen to the internal ground terminal, connect the outer ground terminal to potential equalisation
9. Tighten the compression nut of the cable entry. The seal ring must completely encircle the cable
10. Place probably existing indicating and adjustment module back on
11. Screw the housing cover back on

The electrical connection is hence finished.

5.3 Wiring plan, single chamber housing



The following illustration applies to the non-Ex as well as to the Ex-ia version.

Electronics compartment

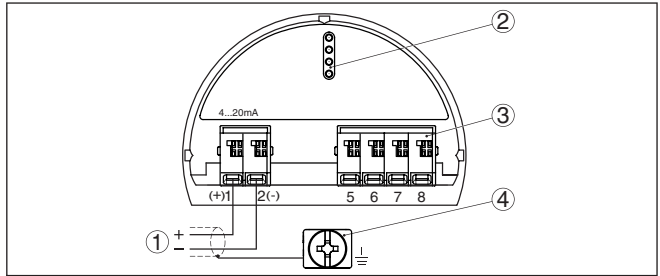

Fig. 10: Electronics and connection compartment, single chamber housing

- 1 Voltage supply, signal output
- 2 For indicating and adjustment module or interface adapter
- 3 For external indicating and adjustment unit
- 4 Ground terminal for connection of the cable screen

5.4 Wiring plan, double chamber housing



The following illustrations apply to the non-Ex as well as to the Ex-ia version.

Electronics compartment

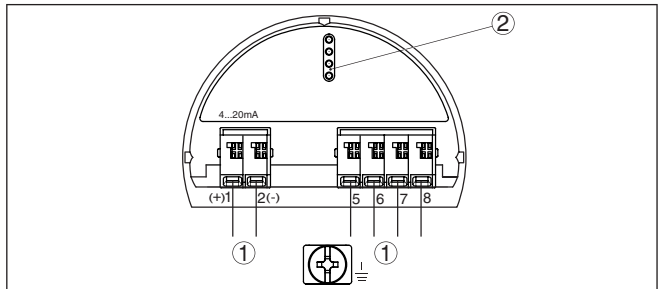

Fig. 11: Electronics compartment, double chamber housing

- 1 Internal connection to the connection compartment
- 2 For indicating and adjustment module or interface adapter

Connection compartment

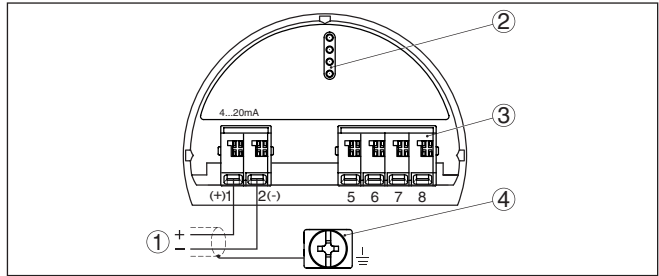

Fig. 12: Connection compartment double chamber housing

- 1 Voltage supply, signal output
- 2 For indicating and adjustment module or interface adapter
- 3 For external indicating and adjustment unit
- 4 Ground terminal for connection of the cable screen

**Information:**

The use of an external indicating and adjustment unit and an indicating and adjustment module in parallel in the connection compartment is not supported.

Radio module PLICSMOBILE integrated in the connection compartment

Fig. 13: Connection of the voltage supply of the radio module

- 1 Voltage supply

You can find detailed information for connection in the supplementary instructions "PLICSMOBILE GSM/GPRS radio module".

5.5 Wiring plan, Ex-d-ia double chamber housing

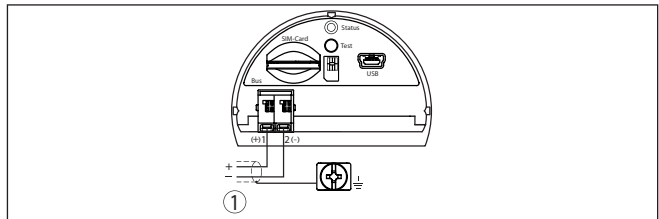
Electronics compartment

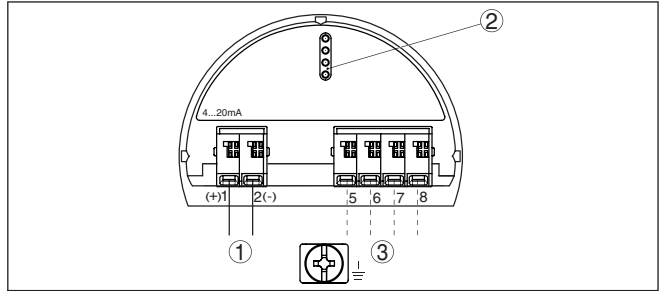

Fig. 14: Electronics compartment, double chamber housing

- 1 Internal connection to the connection compartment
- 2 For indicating and adjustment module or interface adapter
- 3 Internal connection to the plug connector for external indicating and adjustment unit (optional)

Connection compartment

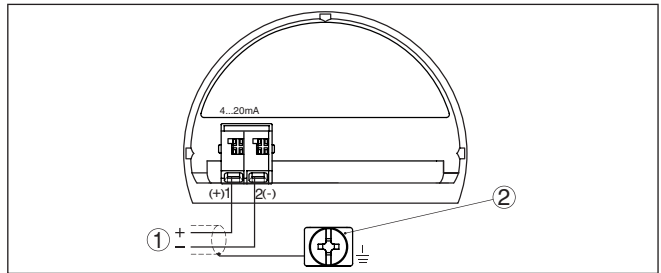

Fig. 15: Connection compartment, Ex-d double chamber housing

- 1 Voltage supply, signal output
- 2 Ground terminal for connection of the cable screen

Plug M12 x 1 for external indicating and adjustment unit

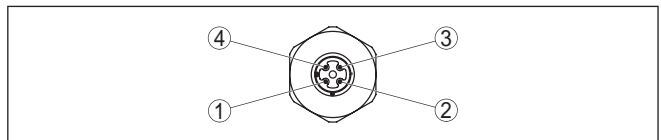

Fig. 16: Top view of the plug connector

- 1 Pin 1
- 2 Pin 2
- 3 Pin 3
- 4 Pin 4

Contact pin	Colour connection cable in the sensor	Terminal, electronics module
Pin 1	Brown	5
Pin 2	White	6
Pin 3	Blue	7

Contact pin	Colour connection cable in the sensor	Terminal, electronics module
Pin 4	Black	8

5.6 Wiring plan - version IP 66/IP 68, 1 bar

Wire assignment, connection cable

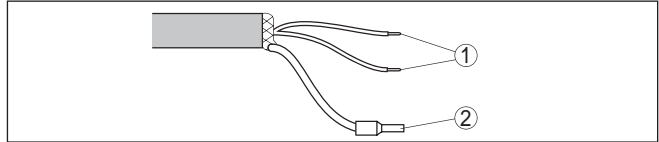

Fig. 17: Wire assignment fix-connected connection cable

- 1 brown (+) and blue (-) to power supply or to the processing system
- 2 Shielding

5.7 Switch-on phase

After connecting the instrument to power supply or after a voltage recurrence, the instrument carries out a self-check for approx. 30 s:

- Internal check of the electronics
- Indication of the instrument type, hardware and software version, measurement loop name on the display or PC
- Indication of the status message "F 105 Determine measured value" on the display or PC
- The output signal jumps to the set error current

As soon as a plausible measured value is found, the corresponding current is outputted to the signal cable. The value corresponds to the actual level as well as the settings already carried out, e.g. factory setting.

6 Set up with the indicating and adjustment module

6.1 Insert indicating and adjustment module

The indicating and adjustment module can be inserted into the sensor and removed any time. Four positions displaced by 90° can be selected. It is not necessary to interrupt the power supply.

Proceed as follows:

1. Unscrew the housing cover
2. Place the indicating and adjustment module in the requested position onto the electronics and turn to the right until it snaps in
3. Screw housing cover with inspection window tightly back on

Removal is carried out in reverse order.

The indicating and adjustment module is powered by the sensor, an additional connection is not necessary.



Fig. 18: Insertion of the indicating and adjustment module with single chamber housing into the electronics compartment

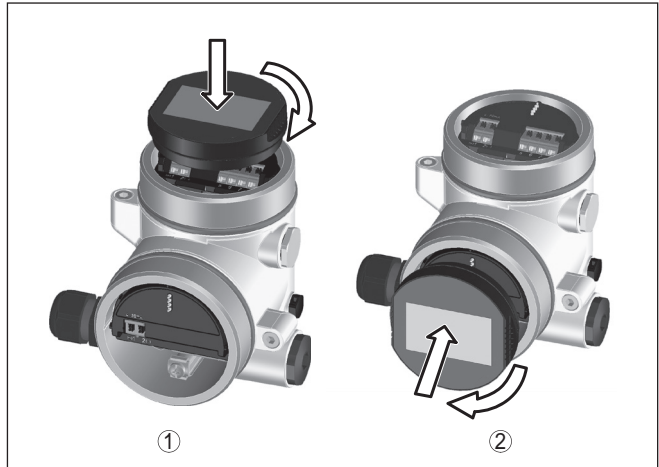

Fig. 19: Insertion of the indicating and adjustment module with double chamber housing

- 1 In the electronics compartment
- 2 In the connection compartment (with Ex-d-ia version not possible)



Note:

If you intend to retrofit the instrument with an indicating and adjustment module for continuous measured value indication, a higher cover with an inspection glass is required.

6.2 Adjustment system

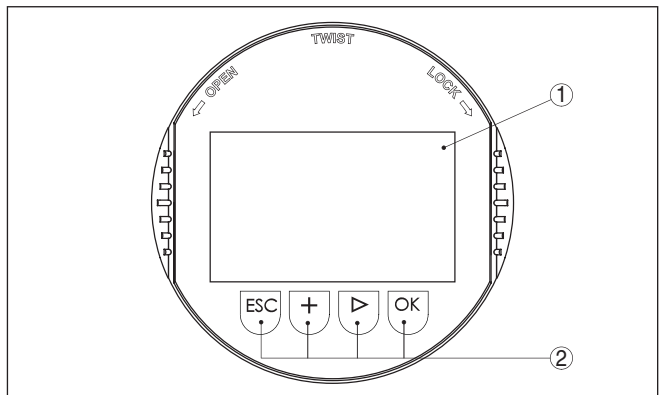

Fig. 20: Indicating and adjustment elements

- 1 LC display
- 2 Adjustment keys

Key functions

- **[OK]** key:
 - Move to the menu overview
 - Confirm selected menu

- Edit parameter
- Save value
- [->] key:
 - Presentation change measured value
 - Select list entry
 - Select editing position
- [+] key:
 - Change value of the parameter
- [ESC] key:
 - interrupt input
 - Jump to next higher menu

Adjustment system

The sensor is adjusted via the four keys of the indicating and adjustment module. The LC display indicates the individual menu items. The functions of the individual keys are shown in the above illustration. Approx. 10 minutes after the last pressing of a key, an automatic reset to measured value indication is triggered. Any values not confirmed with [OK] will not be saved.

6.3 Parameter adjustment

Through the parameter adjustment the instrument is adapted to the application conditions. The parameter adjustment is carried out via an adjustment menu.

Main menu

The main menu is divided into five sections with the following functions:

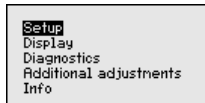

Setup: Settings, for example to measurement loop name, medium, vessel, adjustment, signal output, device unit, false signal suppression, linearization curve

Display: Settings, e.g., for language, measured value display, lighting

Diagnostics: Information, e.g. on the instrument status, pointer, reliability, simulation, echo curve

Additional adjustments: Reset, date/time, reset, copying function

Info: Instrument name, hardware and software version, calibration date, instrument features



Note:

For optimum adjustment of the measurement, the individual submenu items in the main menu item "Setup" should be selected one after the other and provided with the correct parameters. If possible, go through the items in the given sequence.

The procedure is described below.

Lock/release setup/adjustment

In the menu item "*Block/allow adjustment*", you can protect the sensor parameters against unauthorized modification. The PIN is activated/deactivated permanently.

The following adjustment functions are possible without entering the PIN:

- Select menu items and show data
- Read data from the sensor into the indicating/adjustment module.



Caution:

With active PIN, the adjustment via PACTware/DTM as well as other systems is also blocked.

You can change the PIN number under "*Additional adjustments/PIN*".

Setup/Measurement loop name

Here you can assign a suitable measurement loop name. Push the "**OK**" key to start the processing. With the "+" key you change the sign and with the "->" key you jump to the next position.

You can enter names with max. 19 characters. The character set comprises:

- Capital letters from A ... Z
- Numbers from 0 ... 9
- Special characters + - / _ blanks

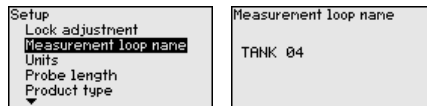

Setup/Units

In this menu item you select the distance unit and the temperature unit.

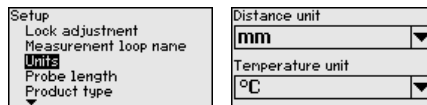

With the distance units you can choose between m, mm and ft and with the temperature units between °C, °F and K.

Setup/Probe length

In this menu item you can enter the probe length or have the length determined automatically by the sensor system.

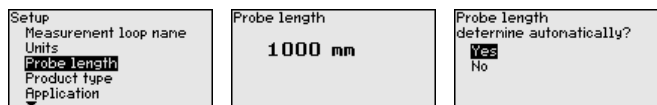

When choosing "Yes", then the probe length will be determined automatically. When choosing "No", you can enter the probe length manually.

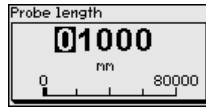

Setup/Medium type

In this menu item you can select which type of medium you want to measure. You can choose between liquid or bulk solid.

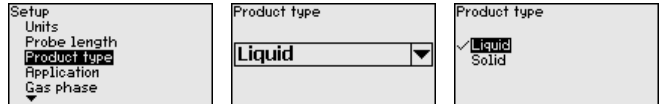

Setup/Application

In this menu item, you can select the application. You can choose between level measurement and interface measurement. You can also choose between measurement in the vessel or in the bypass or standpipe.



Note:

The selection of the application has a considerable influence on all other menu items. Keep in mind that as you continue with the parameter adjustment, individual menu items are only optionally available.

You have the possibility to choose the demonstration mode. This mode is suitable for test and demonstration purposes. In this mode, the sensor ignores the logic parameters of the application and reacts immediately to each change.

You have to enter the tube inner diameter when measuring in a bypass or standpipe.

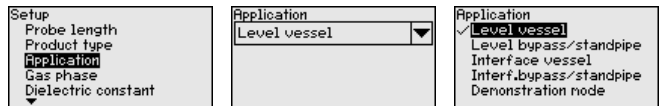

Setup/Medium, dielectric constant

In this menu item, you can define the medium type (product).

This menu item is only available if you have selected level measurement under the menu item "Application".

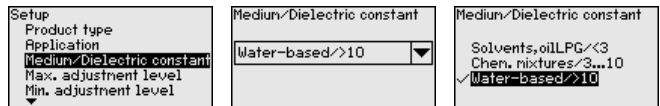

You can choose between the following medium types:

Dielectric constant	Product type	Examples
≥ 10	Water-based liquids	Acids, alcalis, water
$> 3 \dots < 10$	Chemical mixtures	Chlorobenzene, nitro lacquer, aniline, isocyanate, chloroform
≤ 3	Hydrocarbons	Solvents, oils, liquid gas

Setup/Gas phase

This menu item is only available, if you have chosen interface measurement under the menu item "Application". In this menu item you can enter if there is a superimposed gas phase in your application.

Only set the function to "Yes", if the gas phase is permanently present.

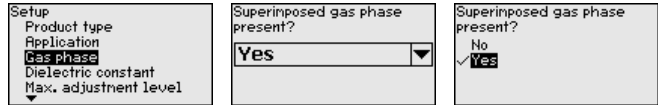

Setup/Dielectric constant

This menu item is only available if you have selected interface measurement under the menu item "Application". In this menu item you can choose the medium type of the upper medium.

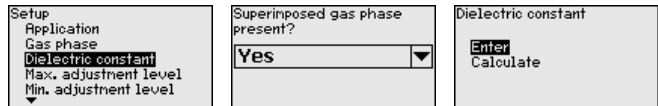

You can directly enter the dielectric constant of the upper medium

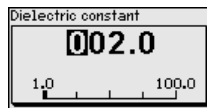

or have it determined by the instrument. You have to enter the measured distance to the interface.

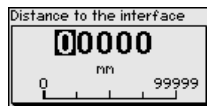

Setup/Max. adjustment - Level

In this menu item you can enter the max. adjustment for the level. This is the max. total level with interface measurement.

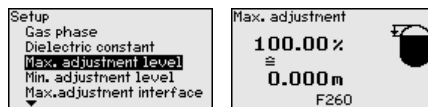

Adjust the requested percentage value with [+/-] and save with [OK].

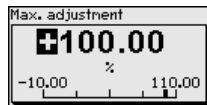

Enter the appropriate distance value in m (corresponding to the percentage value) for the full vessel. The distance refers to the sensor reference plane (seal surface of the process fitting). Keep in mind that the max. level must lie below the dead band.

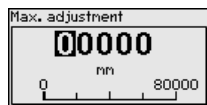

Setup/Min. adjustment - Level

In this menu item you can enter the min. adjustment for the level. This is the min. total level with interface measurement.

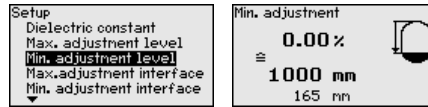

Adjust the requested percentage value with **[+]** and save with **[OK]**.

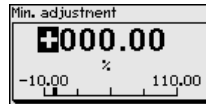

Enter the suitable distance value in m for the empty vessel (e.g. distance from the flange to the probe end) corresponding to the percentage value. The distance refers to the sensor reference plane (seal surface of the process fitting).

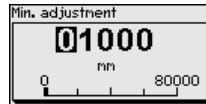

Setup/Max. adjustment - Interface

This menu item is only available if you have selected interface measurement under the menu item "Application".

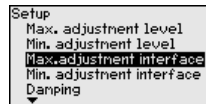

You can accept the adjustment of the level measurement also for the interface measurement. If you select "Yes", the actual setting will be displayed.

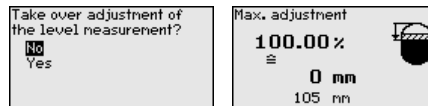

If you have selected "No", then you can enter the adjustment for the interface separately. Enter the requested percentage value.

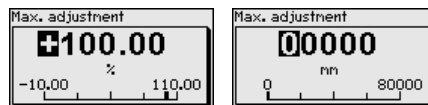

Enter the distance value in m for the full vessel suitable for the percentage value.

Setup/Min. adjustment - Interface

This menu item is only available if you have selected interface measurement under the menu item "Application". If you have selected "Yes" in the previous menu item (accept adjustment of the level measurement), then the actual setting will be displayed.

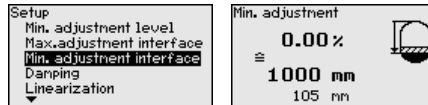

If you have selected "Nein", then you can enter the adjustment for the interface measurement separately.

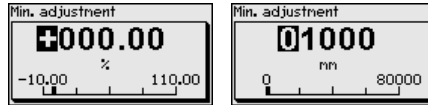

Enter the respective distance value in m for the empty vessel corresponding to the percentage value.

Setup/Damping

To damp process-dependent measured value fluctuations, you have to set an integration time of 0 ... 999 s in this menu item.

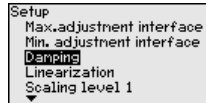

If you have selected interface measurement under the menu item "Application", you can adjust the damping for the level and the interface separately.

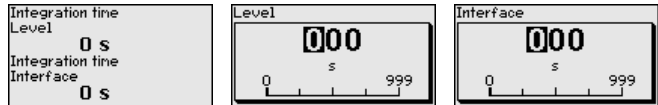

The default setting is a damping of 0 s.

Setup/Linearization

A linearization is necessary for all vessels in which the vessel volume does not increase linearly with the level - e.g. in a horizontal cylindrical or spherical tank when the indication or output of the volume is required. Corresponding linearization curves are preprogrammed for these vessels. They represent the correlation between the level percentage and vessel volume.

The linearization applies to the measured value indication and the current output. By activating the appropriate curve, the volume percentage of the vessel is displayed correctly. If the volume should not be displayed in percent but e.g. in l or kg, a scaling can also be set in the menu item "Display".

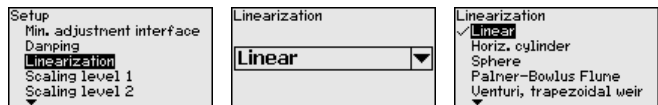

Caution:

Note the following, if the respective sensor is used as part of an over-fill protection system according to WHG:

If a linearisation curve is selected, the measuring signal is no longer linearly proportional to the level. This must be taken into consideration

by the user, particularly when setting the switching point on the level switch.

Setup/Scaling - Level 1

Since the scaling is very comprehensive, the scaling of the level value was divided into two menu items. In the menu item "Level 1" you define the scaling size and the scaling unit for the level value on the display, e.g. volume in l.

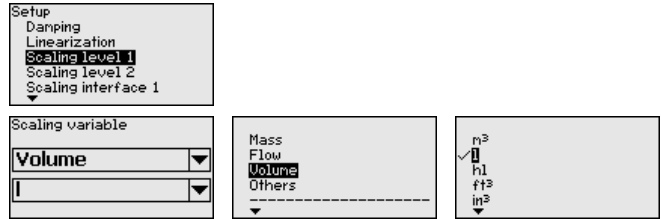

Setup/Scaling - Level 2

Since the scaling is very comprehensive, the scaling of the level value was divided into two menu items.

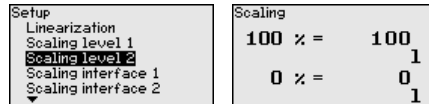

In menu item "Level 2" you define the scaling format on the display and the scaling of the level measured value for 0 % and 100 %.

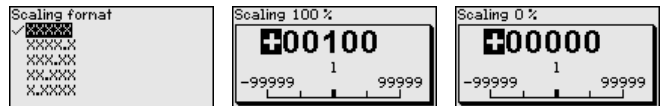

Setup/Scaling - Interface 1

Since the scaling is very comprehensive, the scaling of the interface measured value was divided into two menu items. In the menu item "Interface 1" you define the scaling size and the scaling unit for the interface value on the display, e.g. volume in l.

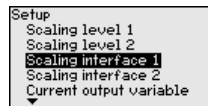

You can accept the scaling of the level measurement also for the interface measurement. If you select "Yes", the actual setting will be displayed.

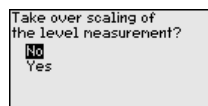

If you have selected "No", then you can enter the scaling for the interface separately.

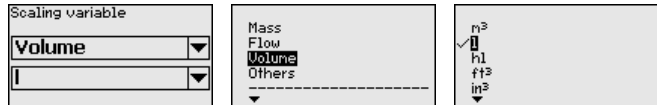

Setup/Scaling - Interface 2

Since the scaling is very extensive, the scaling of the interface measured value was divided into two menu items.

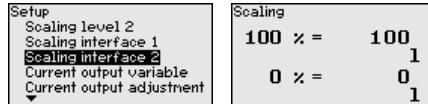

In menu item "Interface 2" you define the scaling format on the display and the scaling of the interface measured value for 0 % and 100 %.

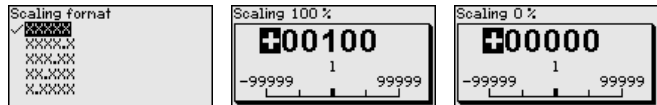

Setup/Current output - Size

In menu item "Current output, size" you determine which measured value the current output refers to.

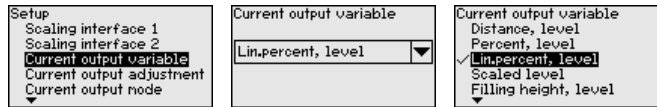

Setup/Current output - Adjustment

In menu item "Current output, adjustment" you can assign a respective measured value to the current output.

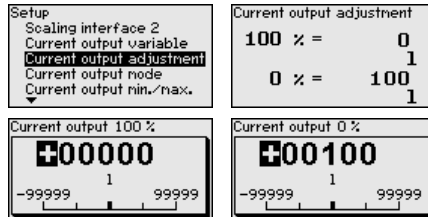

Setup/Current output Min./Max.

In the menu item "Current output Min./Max.", you determine the reaction of the current output during operation.

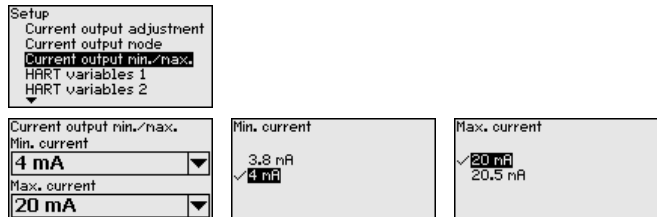

The default setting is min. current 3.8 mA and max. current 20.5 mA.

Setup/HART variables 1

Since the HART variables are very extensive, the indication was divided into two menu items. In the menu item "HART variables 1" you can have the first HART value PV (primary value) and the second HART value SV (second value) of the sensor displayed.

A change of the values is not possible in the indicating and adjustment module. To change these values, you have to use the adjustment software PACTware.

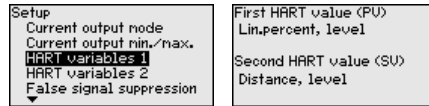

Setup/HART variables 2

Since the HART variables are very extensive, the indication was divided into two menu items. In the menu item "HART variables 2" you can have the third HART value TV (third value) and the fourth HART value QV (quarter value) of the sensor displayed.

A change of the values is not possible in the indicating and adjustment module. To change these values, you have to use the adjustment software PACTware.

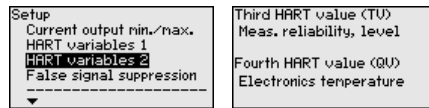

Setup/False signal suppression

The following circumstances cause interfering reflections and can influence the measurement:

- High sockets
- Vessel installations such as struts



Note:

A false signal suppression detects, marks and saves these false signals so that they are no longer taken into account for the level and interface measurement. We generally recommend carrying out a false signal suppression to achieve the best possible accuracy. This should be done with the lowest possible level so that all potential interfering reflections can be detected.

Proceed as follows:

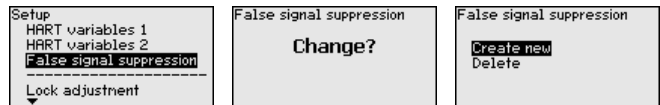

Enter the actual distance from the sensor to the product surface.

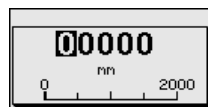

All interfering signals in this section are detected by the sensor and stored.

**Note:**

Check the distance to the product surface, because if an incorrect (too large) value is entered, the existing level will be saved as false signal. The filling level would then no longer be detectable in this area. If a false signal suppression has already been created in the sensor, the following menu window appears when selecting "False signal suppression":



The instrument carries out an automatic false signal suppression as soon as the probe is uncovered.

The menu item "Delete" is used to completely delete an already created false signal suppression. This is useful if the saved false signal suppression no longer matches the metrological conditions in the vessel.

Display/Menu language

This menu item enables the setting of the requested national language.

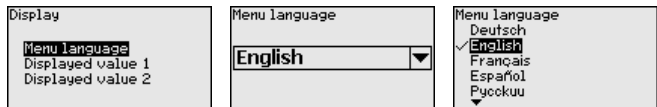

In the delivery status, the sensor is set to the ordered national language.

Display/Displayed value 1

In this menu item, you define the indication of the measured value on the display. You can display two different measured values. In this menu item, you define measured value 1.

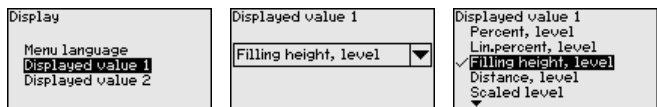

The default setting for the displayed value 1 is "Filling height Level".

Display/Displayed value 2

In this menu item, you define the indication of the measured value on the display. You can display two different measured values. In this menu item, you define measured value 2.

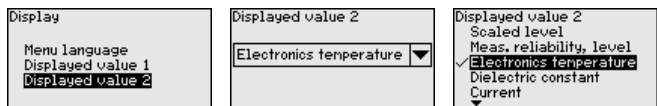

The default setting for the displayed value 2 is the electronics temperature.

Display/Backlight

The optionally integrated background lighting can be adjusted via the adjustment menu. The function depends on the height of the supply voltage, see "Technical data".

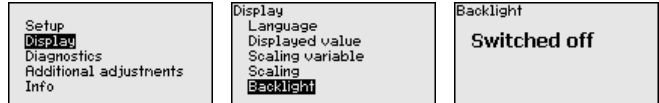

The lighting is switched off in the delivery status.

Diagnostics/Device status

In this menu item, the device status is displayed.

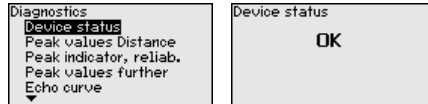

Diagnostics/Peak values - Distance

The respective min. and max. measured value is saved in the sensor. The two values are displayed in the menu item "*Peak values, distance*".

If you have selected interface measurement under the menu item "*Setup/Application*", then the peak values of the interface measurement are displayed in addition to the peak values of the level measurement.

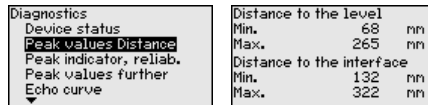

In another window you can carry out a reset of the two peak values separately.

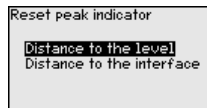

Diagnostics/Peak values - Measurement certainty

The respective min. and max. measured values are saved in the sensor. The two values are displayed in the menu item "*Peak values, measurement certainty*".

The measurement can be influenced by the process conditions. In this menu item, the measurement certainty of the level measurement is displayed as percentage value. The higher the value, the more reliable the measurement. Values > 90 % indicate reliable measurement.

If you have selected interface measurement under the menu item "*Setup/Application*", then the peak values of the interface measurement are displayed in addition to the peak values of the level measurement.

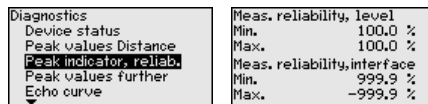

In another window you can carry out a reset of the two peak values separately.

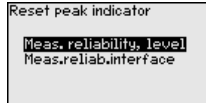

Diagnostics/Peak values - Further

The respective min. and max. measured values are saved in the sensor. The values are displayed in the menu item "Peak values - Additional".

This menu item displays the peak values of the electronics temperature as well as the dielectric constant.

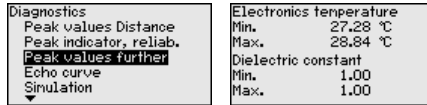

In another window you can carry out a reset of the two peak values separately.

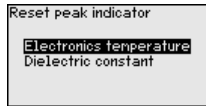

Diagnostics/Echo curve

The menu item "Echo curve" shows the signal strength of the echoes over the measuring range in V. The signal strength enables an evaluation of the quality of the measurement.

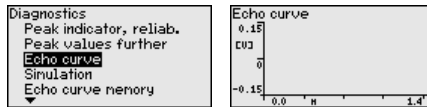

With the following functions you can zoom part sections of the echo curve.

- "X-Zoom": Zoom function for the meas. distance
- "Y-Zoom": 1, 2, 5 and 10x signal magnification in "V"
- "Unzoom": Reset the presentation to the nominal measuring range with single magnification

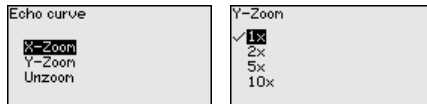

Diagnostics/Simulation

In this menu item you can simulate measured values via the current output. This allows the signal path to be tested, e.g. via downstream indicating instruments or the input card of the control system.

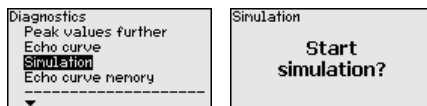

Select the requested simulation size and adjust the requested value.

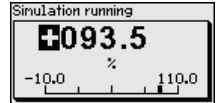
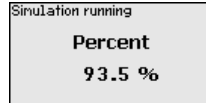
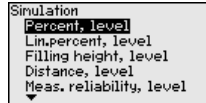

Caution:

During simulation, the simulated value is outputted as 4 ... 20 mA current value and digital HART signal.

Push the **[ESC]** key to interrupt the simulation.



Information:

The simulation is automatically terminated 10 minutes after the last press of a key.

Diagnostics/Echo curve memory

The function "Echo curve memory" enables storing echo curves of the measurement.

Under the sub-menu item "Echo curve memory" you can activate or deactivate the storing of the echo curve.

The parameters for recording the echo curve and the settings of the echo curve can be carried out in the adjustment software PACTware. With this menu item you can only start or stop the storing process.

With the adjustment software PACTware and the PC the high-resolution echo curve can be displayed and used later on to assess the quality of the measurement.

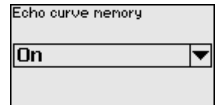
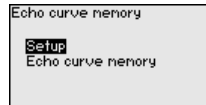
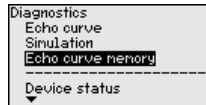

With the menu item "Setup" the echo curve it is possible to save at the time of setup. This is generally recommended; for using the Asset Management functions it is necessary. If possible, the curve should be saved with a low level in the vessel.

With this, you can detect signal changes over the operating time. With the adjustment software PACTware and the PC, the high-resolution echo curve can be displayed and used to compare the echo curve of the setup with the actual echo curve.

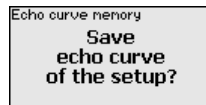
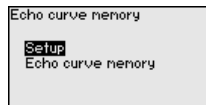

Additional adjustments/ PIN

Entering a 4-digit PIN protects the sensor data against unauthorized access and unintentional modification. In this menu item, the PIN is displayed or edited and changed. However, this menu item is only available if adjustment is enabled in the menu "Lock/Release setup/ adjustment".

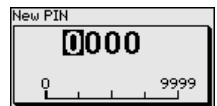
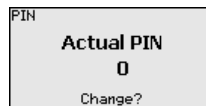
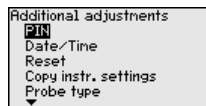

In delivery status, the PIN is "0000".

Additional adjustments/ Date time

In this menu item, the internal clock of the sensor is adjusted.



Additional adjustments - Reset

With a reset, certain parameter adjustments carried out by the user are reset.

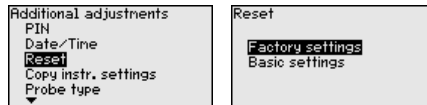

The following reset functions are available:

Delivery status: Restoring the parameter settings at the time of shipment from the factory incl. the order-specific settings. A created false signal suppression, user-programmable linearization curve as well as the measured value memory will be deleted.

Basic settings: Resetting the parameter settings incl. special and laboratory parameters to the default values of the respective instrument. A created false signal suppression, user programmable linearization curve as well as the measured value memory will be deleted.

The following table shows the default values of the instrument. Depending on the instrument version or application, all menu items may not be available or some may be differently assigned:

Menu	Menu item	Default value
Setup	Lock operation	Released
	Measurement loop name	Sensor
	Units	Distance unit: mm Temperature unit: °C
	Probe length	Length of the probe Ex factory
	Product type	Liquid
	Applications	Level, vessel
	Medium, dielectric constant	Water-based, > 10
	Max. adjustment	0.000 m(d) - note blocking distances
	Min. adjustment	Probe length - take dead band into account
	Linearisation	Linear
	Damping	0.0 s
	Scaling size	Volume in l
	Current output - adjustment	0.00 lin %, 0 l 100.00 lin %, 100 l
	Current output - mode	Last measured value
Current output - Min./Max.	Min. current 3.8 mA, max. current 20.5 mA	
Display	Language	As set in the device
	Displayed value 1	Filling height, level
	Displayed value 2	Electronics temperature
	Backlight	Switched off
Additional adjustments	PIN	0000
	Probe type	Like order
	HART mode	Address 0 - Standard

**Additional adjustments/
Copy instrument settings**

The instrument settings are copied with this function. The following functions are available:

- read from sensor: Read data from sensor and store into the indicating and adjustment module
- write into sensor: Store data from the indicating and adjustment module back to the sensor

The following data or settings for adjustment of the indicating and adjustment module are saved:

- All data of the menu "Setup" and "Display"
- In the menu "Additional adjustments" the items "Reset, Date/Time"
- Special parameters

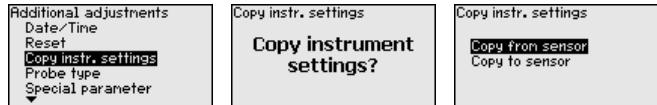

The copied data are permanently saved in an EEPROM memory in the indicating and adjustment module and remain there even in case of power failure. From there, they can be written into one or more sensors or kept as backup for a possible electronics exchange.



Note:

Before the data are stored in the sensor, a check is carried out to determine if the data fit the sensor. If the data do not fit, a fault signal is triggered or the function is blocked. When data are being written into the sensor, the display shows which instrument type the data originate from and which TAG-no. this sensor had.

**Additional adjustments/
Probe type**

In this menu item you can select the type and size of your probe from a list of all possible probes. This is necessary to adapt the electronics optimally to the probe.

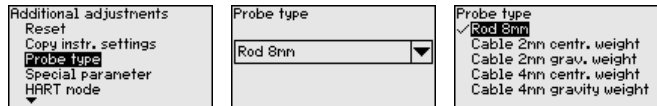

**Additional adjustments/
Special parameters**

In this menu item you gain access to the protected area where you can enter special parameters. In exceptional cases, individual parameters can be modified in order to adapt the sensor to special requirements.

Change the settings of the special parameters only after having contacted our service staff.

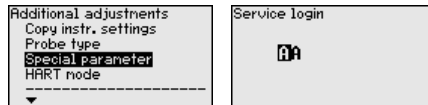

**Additional adjustments/
HART mode**

The sensor offers the HART modes "Analogue current output" and "Fix current (4 mA)". In this menu item you determine the HART mode and enter the address with Multidrop mode.

In the mode "Fix current output" up to 63 sensors can be operated on one two-wire cable (Multidrop operation). An address between 0 and 63 must be assigned to each sensor.

If you select the function "Analogue current output" and also enter an address number, you can output a 4 ... 20 mA signal in Multidrop mode.

In mode "Fix current (4 mA)" a fix 4 mA signal is outputted independent from the actual level.

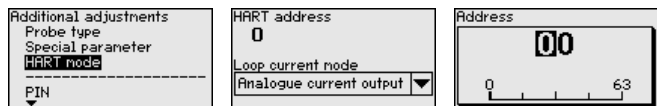

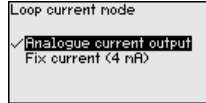

The default setting is "Analogue current output" and the address 00.

Info/Instrument name

In this menu, you read out the instrument name and the instrument serial number:

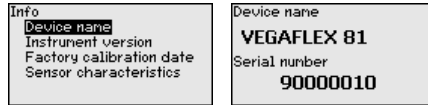

Info/Instrument version

In this menu item, the hardware and software version of the sensor is displayed.

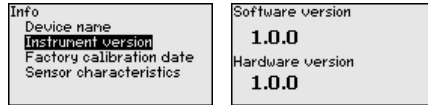

Info/Factory calibration date

In this menu item, the date of factory calibration of the sensor as well as the date of the last change of sensor parameters are displayed via the indicating and adjustment module or via the PC.

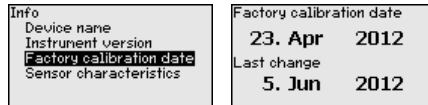

Info/Sensor characteristics

In this menu item, the features of the sensor such as approval, process fitting, seal, measuring range, electronics, housing and others are displayed.

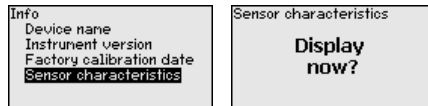

6.4 Saving the parameter adjustment data

We recommended noting the adjusted data, e.g. in this operating instructions manual, and archiving them afterwards. They are thus available for multiple use or service purposes.

If the instrument is equipped with an indicating and adjustment module, the data in the sensor can be saved in the indicating and adjustment module. The procedure is described in the operating instructions manual "*Indicating and adjustment module*" in the menu item "*Copy sensor data*". The data remain there permanently even if the sensor power supply fails.

The following data or settings for adjustment of the indicating and adjustment module are saved:

- All data of the menu "Setup" and "Display"
- In the menu "Additional adjustments" the items "Sensor-specific units, temperature unit and linearization"
- The values of the user programmable linearisation curve

The function can also be used to transfer settings from one instrument to another instrument of the same type. If it is necessary to exchange a sensor, the indicating and adjustment module is inserted into the replacement instrument and the data are likewise written into the sensor via the menu item "Copy sensor data".

7 Setup with PACTware

7.1 Connect the PC

Via the interface adapter directly on the sensor

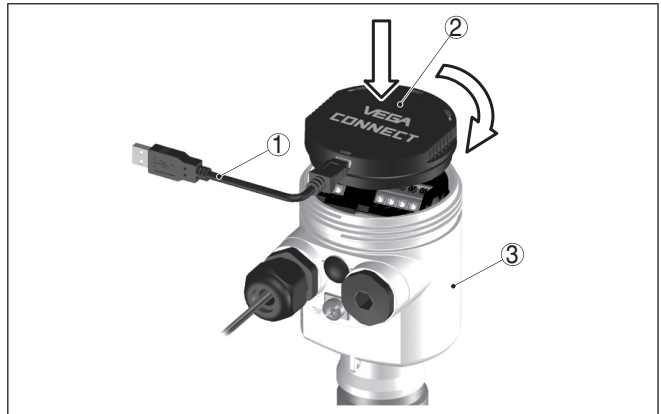

Fig. 21: Connection of the PC directly to the sensor via the interface adapter

- 1 USB cable to the PC
- 2 Interface adapter VEGACONNECT 4
- 3 Sensor



Information:

The interface adapter VEGACONNECT 3 is not suitable for connection to the sensor.

Via the interface adapter and HART

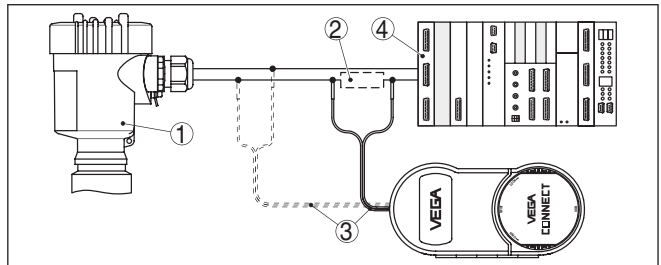

Fig. 22: Connecting the PC via HART to the signal cable

- 1 Sensor
- 2 HART resistance 250 Ω (optional depending on processing)
- 3 Connection cable with 2 mm pins and terminals
- 4 Processing system/PLC/Voltage supply
- 5 Interface adapter, for example VEGACONNECT 4



Note:

With power supply units with integrated HART resistance (internal resistance approx. 250 Ω), an additional external resistance is not necessary. This applies, e.g. to the VEGA instruments VEGATRENN 149A, VEGAMET 381, VEGAMET 391. Common Ex separators are also usually equipped with a sufficient current limitation resistance. In

such cases, the interface converter can be connected parallel to the 4 ... 20 mA cable (dashed line in the previous illustration).

7.2 Parameter adjustment with PACTware

Prerequisites

For parameter adjustment of the sensor via a Windows PC, the configuration software PACTware and a suitable instrument driver (DTM) according to FDT standard are required. The up-to-date PACTware version as well as all available DTMs are compiled in a DTM Collection. The DTMs can also be integrated into other frame applications according to FDT standard.



Note:

To ensure that all instrument functions are supported, you should always use the latest DTM Collection. Furthermore, not all described functions are included in older firmware versions. You can download the latest instrument software from our homepage. A description of the update procedure is also available in the Internet.

Further setup steps are described in the operating instructions manual "DTM Collection/PACTware" attached to each DTM Collection and which can also be downloaded from the Internet. Detailed descriptions are available in the online help of PACTware and the DTMs.

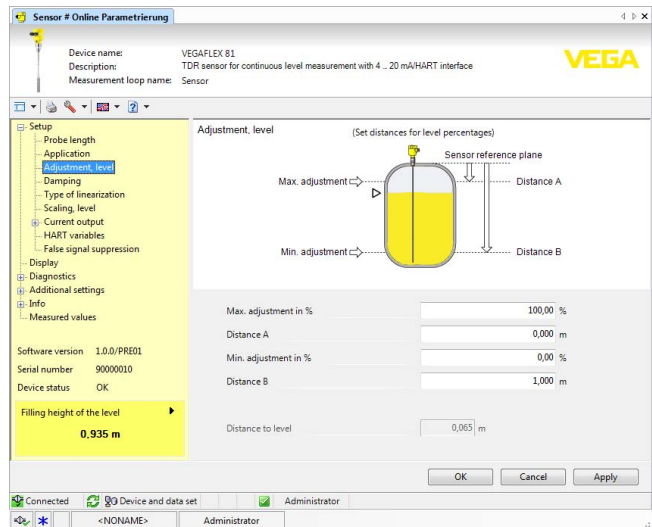

Fig. 23: Example of a DTM view

Standard/Full version

All device DTMs are available as a free-of-charge standard version and as a full version that must be purchased. In the standard version, all functions for complete setup are already included. An assistant for simple project configuration simplifies the adjustment considerably. Saving/printing the project as well as import/export functions are also part of the standard version.

In the full version there is also an extended print function for complete project documentation as well as a save function for measured value and echo curves. In addition, there is a tank calculation program as well as a multiviewer for display and analysis of the saved measured value and echo curves.

The standard version is available as a download under www.vega.com/downloads and "Software". The full version is available on CD from the agency serving you.

7.3 Set up with the quick setup

General information

The quick setup is another option for parameter adjustment of the sensor. It allows fast, convenient adjustment of the most important parameters to adapt the sensor quickly to standard applications. To use it, select the function "Quick setup" in the start screen.

Start quick setup

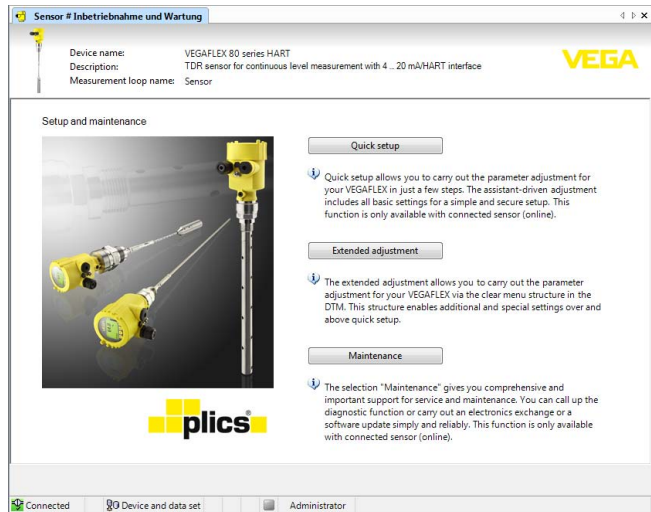

Fig. 24: Select quick setup

- 1 Quick setup
- 2 Extended adjustment
- 3 Maintenance

Quick setup

With quick setup you can carry out the parameter adjustment of VEGAFLEX 83 for your application in just a few simple steps. The assistant-driven adjustment includes the basic settings for simple, reliable setup and commissioning.

Information:

If the function is inactive, then possibly no instrument is connected. Check the connection to the instrument.



Extended adjustment

With the extended adjustment, you carry out the parameter adjustment for the instrument via the clear menu structure in the DTM (Device Type Manager). This enables additional and special settings over and above those offered by quick setup.

Maintenance

Under the menu item "*Maintenance*" you get comprehensive and important support for servicing and maintenance. You can call up diagnostic functions and carry out an electronics exchange or a software update.

Step 1 of 7 Instrument configuration

Device name

Here, you can find the instrument name. You cannot change this line because the instrument name is unmodifiably saved in the instrument.

Serial number

Here, you can find the serial number of your instrument. You cannot change this line because the serial number is unmodifiably saved in the instrument.

Measurement loop name

Here you can enter a suitable measurement loop name for your VEGAFLEX 83. You can enter a name with max. 19 characters. You can use capital and small letters as well as numbers. The following special characters are also possible: + - . : , () / < >

Probe length modified?

If you have modified the probe length, this must be entered in the selection field.

- If you select "No", then the instrument uses automatically the preset length of the default setting.
- If you select "Yes", then you can enter in another field the modified length of the instrument.

Probe length L from seal surface

If you have modified the length of the probe, you can enter in this field the modified probe length. Keep the selected unit in mind.

Determine probe length automatically

If you do not know the probe length, you can have the length of the probe determined automatically. The requirement for this is a probe unrestricted and not covered by the medium.

Click to "*Carry out now*", to start the automatic length determination.

Step 2 of 7 Applications

Product type

Here you can see which medium type your instrument is suitable for. If this function is inactive, the medium type your instrument is suitable for was already preset.

**Information:**

In special cases you can change the medium type. This setting can be changed under "*Extended adjustment*".

Applications

In this field you can select the application you want to use your instrument for. You have the following selection options:

- Level in the vessel
- Level in the bypass/standpipe
- Interface in the vessel
- Interface in the bypass/standpipe
- Demonstration mode

Level measurement: If you select "Level", you can select the properties of the medium in another field.

Interface measurement: If you select "Interface", the instrument needs more information, such as the distance to the interface, the dielectric constant of the upper medium or whether or not there is a superimposed gas phase.

Demonstration mode: This mode is suitable for test and demonstration purposes. In this mode, the sensor ignores all logic parameters and reacts immediately to all measured value changes within the measuring range.

Application - Level measurement

The level measurement refers to the product surface which is the limit to the gas phase.

- Liquids
 - Solvents, oils, LPG - dielectric constant ≤ 3
 - Chemical mixtures - dielectric constant $> 3 \dots < 10$
 - Water-based - dielectric constant ≥ 10
- Bulk solids
 - Dusts, wood chips - dielectric constant ≤ 1.5
 - Granules, dusts, powder - dielectric constant $> 1.5 \dots < 3$
 - Cereals, flour - dielectric constant ≥ 3

Application - Interface measurement

The interface measurement refers to the phase limit between two liquids. The total level is also available as a measured value.

- Superimposed gas phase present
 - Check if there is a superimposed gas phase in the vessel. This is always the case if the total level is never at the process fitting.
- Properties
 - Here you can enter the dielectric constant of the upper medium
 - As an alternative you can enter the distance to the interface

Step 3 of 7 Adjustment

Adjustment for the level measurement

If you have selected level measurement in the previous menu, then you can enter the values for the min. and max. adjustment. The value to be entered refers to the distance from the sealing surface of the process fitting (sensor reference plane) to the surface of the product.

Adjustment for the level and interface measurement

If you have selected interface measurement in the previous menu, then you can enter the values for the min. and max. adjustment of level and interface or accept the values of the level measurement. The

entered value refers to the distance from the sealing surface of the process fitting (sensor reference plane) to the total level or interface.

Step 4 of 7 Linearisation

Linearization is required if the measured value should be outputted in proportion to the volume and not the level. The linearization acts identically on the level and the interface measurement. You can find further linearization types in the extended adjustment.

If you have a non-linear vessel, you can select here the respective linearization curve.

- Linear
- Spherical tank
- Horizontal cylindrical tank
- User programmable
- Venturi, trapezoidal weir, rectangular weir
- Palmer-Bowlus-Flume
- V-Notch, rectangular weir

You must enter the following vessel dimensions with non-linear conditions:

- Height of the socket h
- Vessel height D

Step 5 of 7 Setting - Output signal

In this window you can adjust the output signal. When the function is inactive, you can change the settings via the "*Extended adjustment*".

Step 6 of 7 Sensor optimization

These settings allow you to optimize the sensor. With them you can compare a sounded distance with the indicated value and correct it, if necessary.

Probe immersed in the liquid (covered)

Select whether or not the probe is immersed in the medium.

Measured distance to the medium

If the probe is immersed in the medium, you can enter here the measured distance to the medium.

Displayed distance correct?

Is the displayed distance value correct? If you have the possibility, you can enter here the sounded distance to the medium.

False signal suppression

With this function you can carry out the automatic false signal suppression. We recommend carrying out false signal suppression in any case.

Step 7 of 7 Additional settings

When the setup of the instrument is finished, additional settings can be made. These are various backups and the locking of the instrument against unauthorised or inadvertent adjustment.

Prepare a backup file of the instrument parameter adjustment?

For backup purposes, the current parameter adjustment of the instrument is stored in a file. You can use this file later on to restore the

instrument parameter adjustment. The complete data set is downloaded from the device. This procedure can last several minutes.

Create instrument documentation?

This function is used to print or create a PDF file of the current parameter adjustment. To read the PDF file, you need a suitable program (for example Acrobat Reader). To print or create the PDF file, all data are downloaded from the device. For this function, the full version of the DTM Collection is required. This procedure can last several minutes.

Store echo curve of the setup in the sensor?

Did you terminate the first setup of the instrument? In such case, we recommend storing the current signal conditions in the device for later instrument tests and diagnostics.

Lock adjustment with PIN after setting?

The instrument is locked with the current PIN. A parameter adjustment is possible only after the PIN is entered again.

7.4 Saving the parameter adjustment data

We recommend documenting or saving the parameter adjustment data via PACTware. That way the data are available for multiple use or service purposes.

8 Set up with other systems

8.1 DD adjustment programs

Device descriptions as Enhanced Device Description (EDD) are available for DD adjustment programs such as, for example, AMS™ and PDM.

The files can be downloaded under www.vega.com/downloads and "Software".

8.2 Communicator 375, 475

Device descriptions for the instrument are available as DD or EDD for parameter adjustment with the Field Communicator 375 or 475.

The files can be downloaded under www.vega.com/downloads and "Software".

9 Diagnostics and service

9.1 Maintenance

If the device is used correctly, no maintenance is required in normal operation.

9.2 Diagnosis memory

The instrument has several memories which are available for diagnosis purposes. The data remain even with voltage interruption.

Measured value memory

Up to 100,000 measured values can be stored in the sensor in a ring memory. Each entry contains date/time as well as the respective measured value. Storable values are for example:

- Distance
- Filling height
- Percentage value
- Lin. percent
- Scaled
- Current value
- Meas. reliability
- Electronics temperature

When the instrument is shipped, the measured value memory is active and stores every 3 minutes distance, measurement certainty and electronics temperature.

In the "Extended operation", you can select the respective measured values.

The requested values and recording conditions are set via a PC with PACTware/DTM or the control system with EDD. Data are thus read out and also reset.

Event memory

Up to 500 events are automatically stored with a time stamp in the sensor (non-deletable). Each entry contains date/time, event type, event description and value. Event types are for example:

- Modification of a parameter
- Switching on and off times
- Status messages (according to NE 107)
- Error messages (according to NE 107)

The data are read out via a PC with PACTware/DTM or the control system with EDD.

Echo curve memory

The echo curves are stored with date and time and the corresponding echo data. The memory is divided into two sections:

Echo curve of the setup: This is used as reference echo curve for the measurement conditions during setup. Changes in the measurement conditions during operation or buildup on the sensor can thus be recognized. The echo curve of the setup is stored via:

- PC with PACTware/DTM
- Control system with EDD
- Indicating and adjustment module

Further echo curves: Up to 10 echo curves can be stored in a ring buffer in this memory section. Further echo curves are stored via:

- PC with PACTware/DTM
- Control system with EDD

9.3 Status messages

The instrument features self-monitoring and diagnostics according to NE 107 and VDI/VDE 2650. In addition to the status messages in the following tables there are more detailed error messages available under the menu item "*Diagnostics*" via the indicating and adjustment module, PACTware/DTM and EDD.

Status messages

The status messages are classified in the following categories:

- Failure
- Function check
- Out of specification
- Maintenance requirement

and explained by pictographs:

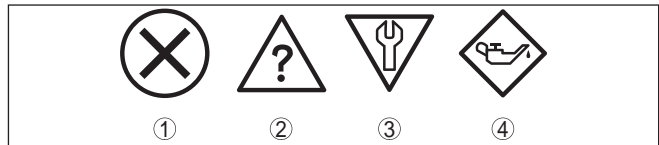

Fig. 25: Pictograms of the status messages

- 1 Failure - red
- 2 Function check - orange
- 3 Out of specification - yellow
- 4 Maintenance - blue

Failure: Due to a malfunction in the instrument, a failure message is outputted.

This status message is always active. It cannot be deactivated by the user.

Function check: The instrument is in operation, the measured value is temporarily invalid (for example during simulation).

This status message is inactive by default. It can be activated by the user via PACTware/DTM or EDD.

Out of specification: The measured value is unstable because the instrument specification is exceeded (e.g. electronics temperature).

This status message is inactive by default. It can be activated by the user via PACTware/DTM or EDD.

Maintenance: Due to external influences, the instrument function is limited. The measurement is affected, but the measured value is still valid. Plan in maintenance for the instrument because a failure is expected in the near future (e.g. due to buildup).

This status message is inactive by default. It can be activated by the user via PACTware/DTM or EDD.

Failure

The following table shows the error codes in the status message "Failure" and gives information on the reason and rectification. Keep in mind that some information is only valid with four-wire instruments.

Code Text message	Cause	Rectification
F013 no measured value available	<ul style="list-style-type: none"> - Sensor does not detect an echo during operation - Process component or probe contaminated or defective 	<ul style="list-style-type: none"> - Check or correct installation and/or parameter adjustment - Clean or exchange process component or probe
F017 Adjustment span too small	<ul style="list-style-type: none"> - Adjustment not within specification 	<ul style="list-style-type: none"> - Change adjustment according to the limit values (difference between min. and max. ≥ 10 mm)
F025 Error in the linearization table	<ul style="list-style-type: none"> - Index markers are not continuously rising, for example unlogical value pairs 	<ul style="list-style-type: none"> - Check values of the linearization table - Delete/create a new linearization table
F036 No operable software	<ul style="list-style-type: none"> - Failed or interrupted software update 	<ul style="list-style-type: none"> - Repeat software update - Check electronics version - Exchanging the electronics - Send instrument for repair
F040 Error in the electronics	<ul style="list-style-type: none"> - Hardware defect 	<ul style="list-style-type: none"> - Exchanging the electronics - Send instrument for repair
F041 Probe loss	<ul style="list-style-type: none"> - Cable probe broken or rod probe defective 	<ul style="list-style-type: none"> - Check probe and exchange, if necessary
F080 General software error	<ul style="list-style-type: none"> - General software error 	<ul style="list-style-type: none"> - Separate operating voltage briefly
F105 Measured value is determined	<ul style="list-style-type: none"> - The instrument is still in the start phase, the measured value could not yet be determined 	<ul style="list-style-type: none"> - Wait for the warm-up phase - Duration depending on the version and parameter adjustment max. 5 min.
F113 Communication error	<ul style="list-style-type: none"> - EMC interferences - Transmission error with the external communication with 4-wire power supply unit 	<ul style="list-style-type: none"> - Remove EMC influences - Exchange 4-wire power supply unit or electronics
F125 Unpermissible electronics temperature	<ul style="list-style-type: none"> - Temperature of the electronics in the non-specified section 	<ul style="list-style-type: none"> - Check ambient temperature - Isolate electronics - Use instrument with higher temperature range
F260 Error in the calibration	<ul style="list-style-type: none"> - Error in the calibration carried out in the factory - Error in the EEPROM 	<ul style="list-style-type: none"> - Exchanging the electronics - Send instrument for repair

Code Text message	Cause	Rectification
F261 Error in the instrument settings	<ul style="list-style-type: none"> - Error during setup - Error when carrying out a reset - False signal suppression faulty 	<ul style="list-style-type: none"> - Carry out a reset - Repeat setup
F264 Installation/ Setup error	<ul style="list-style-type: none"> - Error during setup 	<ul style="list-style-type: none"> - Check or correct installation and/or parameter adjustment - Check probe length
F265 Measurement function disturbed	<ul style="list-style-type: none"> - Sensor no longer carries out a measurement 	<ul style="list-style-type: none"> - Carry out a reset - Separate operating voltage briefly
F266 Incorrect supply voltage	<ul style="list-style-type: none"> - Terminal voltage below specified range 	<ul style="list-style-type: none"> - Check electrical connection - if necessary, increase operating voltage

Function check

The following table shows the error codes and text messages in the status message "*Function check*" and provides information on causes as well as corrective measures.

Code Text message	Cause	Rectification
C700 Simulation active	<ul style="list-style-type: none"> - A simulation is active 	<ul style="list-style-type: none"> - Finish simulation - Wait for the automatic end after 60 mins.

Out of specification

The following table shows the error codes and text messages in the status message "*Out of specification*" and provides information on causes as well as corrective measures.

Code Text message	Cause	Rectification
S600 Unpermissible electronics temperature	<ul style="list-style-type: none"> - Temperature of the electronics in the non-specified section 	<ul style="list-style-type: none"> - Check ambient temperature - Isolate electronics - Use instrument with higher temperature range
S601 Overfilling	<ul style="list-style-type: none"> - Danger of vessel overfilling 	<ul style="list-style-type: none"> - Make sure that there is no further filling - Check level in the vessel

Maintenance

The following table shows the error codes and text messages in the status message "*Maintenance*" and provides information on causes as well as corrective measures.

Code Text message	Cause	Rectification
M500 Error with the reset delivery status	– With the reset to delivery status, the data could not be restored	– Repeat reset – Load XML file with sensor data into the sensor
M501 Error in the non-active linearization table	– Hardware error EEPROM	– Exchanging the electronics – Send instrument for repair
M502 Error in the diagnosis memory	– Hardware error EEPROM	– Exchanging the electronics – Send instrument for repair
M503 Reliability too low	– The echot/noise ratio is the small for a reliable measurement	– Check installation and process conditions – Clean the antenna – Change polarisation direction – Use instrument with higher sensitivity
M504 Error on an device interface	– Hardware defect	– Check connections – Exchanging the electronics – Send instrument for repair
M505 No echo available	– Level echo can no longer be detected	– Clean the antenna – Use a more suitable antenna/sensor – Remove possible false echoes – Optimize sensor position and orientation

9.4 Rectify faults

Reaction when malfunctions occur

The operator of the system is responsible for taking suitable measures to rectify faults.

Procedure for fault rectification

The first measures are:

- Evaluation of fault messages via the indicating and adjustment module
- Check the 4 ... 20 mA signal
- Treatment of measurement errors

Further comprehensive diagnostics options offer a PC with the software PACTware and the suitable DTM. In many cases, the reasons can be determined in this way and faults can be rectified.

Check the 4 ... 20 mA signal

Connect a handmultimeter in the suitable measuring range according to the wiring plan. The following table describes possible errors in the current signal and helps to remove them:

Error	Cause	Rectification
4 ... 20 mA signal not stable	– Level fluctuations	– Set damping according to the instrument via the indicating and adjustment module or PACTware/DTM
4 ... 20 mA signal missing	– Electrical connection faulty	– Check connection according to chapter "Connection steps" and if necessary, correct according to chapter "Wiring plan".
	– Voltage supply missing	– Check cables for breaks; repair if necessary
	– Operating voltage too low or load resistance too high	– Check, adapt if necessary
Current signal greater than 22 mA or less than 3.6 mA	– Electronics module in the sensor defective	– Exchange the instrument or send it in for repair

Treatment of measurement errors

The below tables show typical examples for application-relevant measurement errors. There are two measurement errors:

- Constant level
- Filling
- Emptying

The images in column "Error pattern" show the real level with a broken line and the level displayed by the sensor as a continuous line.

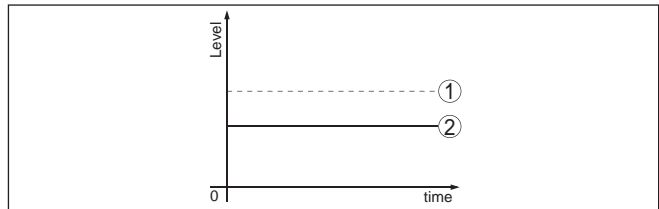

Fig. 26: The broken line 1 shows the real level, the continuous line 2 shows the level displayed by the sensor

i

Note:

- Wherever the sensor displays a constant value, the reason could also be the fault setting of the current output to "Hold value"
- In case of a too low level indication, the reason could be a line resistance that is too high



9.4 Measurement error with constant level

Fault description	Error pattern	Cause	Rectification
1. Measured value shows a too low or too high level		- Min./max. adjustment not correct	- Adapt min./max. adjustment
		- Wrong linearization curve	- Adapt linearization curve
		- Running time error (small measurement error close to 100 %/serious error close to 0 %)	- Repeat setup
2. Measured value jumps towards 100 %		- Due to the process, the amplitude of the product echo sinks	- Carry out false signal suppression
		- A false signal suppression was not carried out	
		- Amplitude or position of a false signal has changed (e.g. buildup); false signal suppression no longer matches	- Determine the reason for the changed false signals, carry out false signal suppression, e.g. with buildup

9.4 Measurement error during filling

Fault description	Error pattern	Cause	Rectification
3. Measured value remains in the area of the bottom during filling		- Echo from the probe end larger than the product echo, for example, with products with $\epsilon_r < 2.5$ oil-based, solvents, etc.	- Check application parameter "Medium" and "Vessel height", adapt if necessary
4. Measured value remains momentarily unchanged during filling and then jumps to the correct level		- Turbulence on the product surface, quick filling	- Check application parameters, change if necessary, e.g. in dosing vessel, reactor
5. measured value jumps sporadically to 100 % during filling		- Varying condensation or contamination on the probe end	- Carry out false signal suppression
6. Measured value jumps to $\geq 100\%$ or 0 m distance		- Level echo is no longer detected in the close range due to false signals in the close range. The sensor goes into overflow protection mode. The max. level (0 m distance) as well as the status message "Overflow protection" are outputted.	- Remove false signals in the close range - Check installation conditions - If possible, switch off the function "Overflow protection"

9.4 Measurement error during emptying

Fault description	Error pattern	Cause	Rectification
7. Measured value remains unchanged in the close range during emptying		<ul style="list-style-type: none"> – False signal larger than the level echo – Level echo too small 	<ul style="list-style-type: none"> – Remove false signals in the close range – Remove contamination on the probe. After having removed the source of the false signals, the false signal suppression must be deleted. – Carry out a new false signal suppression
8. Measured value remains reproducible in one position during emptying		<ul style="list-style-type: none"> – Stored false signals in this position are larger than the level echo 	<ul style="list-style-type: none"> – Delete false signal memory – Carry out a new false signal suppression

Reaction after fault rectification

Depending on the reason for the fault and the measures taken, the steps described in chapter "Setup" must be carried out again or must be checked for plausibility and completeness.

24 hour service hotline

Should these measures not be successful, please call in urgent cases the VEGA service hotline under the phone no. **+49 1805 858550**.

The hotline is also available outside the normal working hours on seven days a week around the clock.

Since we offer this service worldwide, the support is in the English language. The service itself is free of charge, the only costs involved are the normal call charges.

9.5 Exchanging the electronics module

If the electronics module is defective, it can be replaced by the user.



In Ex applications only one instrument and one electronics module with respective Ex approval may be used.

If there is no electronics module available on site, the electronics module can be ordered through the agency serving you. The electronics modules are adapted to the respective sensor and differ in signal output or voltage supply.

The new electronics module must be loaded with the default settings of the sensor. These are the options:

- In the factory
- Or on site by the user

In both cases, the serial number of the sensor is needed. The serial numbers are stated on the type label of the instrument, on the inside of the housing as well as on the delivery note.

When loading on site, first of all the order data must be downloaded from the Internet (see operating instructions manual "Electronics module").

9.6 Software update

The following components are required to update the sensor software:

- Sensor
- Voltage supply
- Interface adapter VEGACONNECT 4
- PC with PACTware
- Current sensor software as file



Caution:

Note that due to a software update you can lose approvals.

You can find the actual sensor software as well as detailed information of the procedure under "www.vega.com/downloads" on "Software".

9.7 How to proceed in case of repair

You can find a repair form as well as detailed information on how to proceed under www.vega.com/downloads and "*Forms and certificates*".

By doing this you help us carry out the repair quickly and without having to call back for needed information.

If a repair is necessary, please proceed as follows:

- Print and fill out one form per instrument
- Clean the instrument and pack it damage-proof
- Attach the completed form and, if need be, also a safety data sheet outside on the packaging
- Please contact for the return shipment the agency serving you. You can find the agency on our home page www.vega.com.

10 Dismounting

10.1 Dismounting steps

**Warning:**

Before dismounting, be aware of dangerous process conditions such as e.g. pressure in the vessel, high temperatures, corrosive or toxic products etc.

Take note of chapters "*Mounting*" and "*Connecting to power supply*" and carry out the listed steps in reverse order.

10.2 Disposal

The instrument consists of materials which can be recycled by specialised recycling companies. We use recyclable materials and have designed the electronics to be easily separable.

Correct disposal avoids negative effects on humans and the environment and ensures recycling of useful raw materials.

Materials: see chapter "*Technical data*"

If you have no way to dispose of the old instrument properly, please contact us concerning return and disposal.

WEEE directive 2002/96/EG

This instrument is not subject to the WEEE directive 2002/96/EG and the respective national laws. Pass the instrument directly on to a specialised recycling company and do not use the municipal collecting points. These may be used only for privately used products according to the WEEE directive.

11 Supplement

11.1 Technical data

General data

316L corresponds to 1.4404 or 1.4435

Materials, wetted parts

- Process fitting PTFE
- Process seal PTFE
- Rod: \varnothing 10 mm (0.394 in) - PFA coated 316L or Hastelloy C22 (2.4602)
- Cable: \varnothing 4 mm (0.157 in) - PFA coated 316 (1.4401)
- Gravity weight PFA coated

Materials, non-wetted parts

- Plastic housing plastic PBT (Polyester)
- Aluminium die-casting housing Aluminium die-casting AlSi10Mg, powder-coated - basis: Polyester
- Stainless steel housing - precision casting 316L
- Stainless steel housing, electropolished 316L
- Seal between housing and housing cover NBR (stainless steel housing, precision casting), silicone (aluminium/plastic housing; stainless steel housing, electropolished)
- Inspection window in housing cover (optional) Polycarbonate (with Ex d version: glass)
- Ground terminal 316L

Process fittings

- Clamp from 2"
- Bolting from DN32 PN40
- Flanges e.g. DIN from DN 25, ANSI from 2"

Weight

- Instrument weight (depending on process fitting) approx. 0.8 ... 8 kg (0.176 ... 17.64 lbs)
- Rod: \varnothing 10 mm (0.394 in) - PFA coated approx. 330 g/m (3.55 oz/ft)
- Cable: \varnothing 4 mm (0.157 in) - PFA coated approx. 41 g/m (0.44 oz/ft)
- Gravity weight (long) for cable \varnothing 4 mm (0.157 in) 325 g (11.5 oz)

Probe length L (from seal surface)

- Rod: \varnothing 10 mm (0.394 in) - PFA coated up to 4 m (13.12 ft)
- Trimming accuracy - rod < 1 mm (0.039 in)
- Cable: \varnothing 4 mm (0.157 in) - PFA coated up to 32 m (105 ft)
- Trimming accuracy - cable ± 0.05 %

Lateral load with rod: \varnothing 10 mm (0.394 in) 4 Nm (3 lbf ft)
- PFA coated

Max. tensile load with cable: \varnothing 4 mm 2 KN (450 lbf)
(0.157 in) - PFA coated

Torque for NPT cable glands and Conduit tubes

- Plastic housing max. 10 Nm (7.376 lbf ft)
- Aluminium/Stainless steel housing max. 50 Nm (36.88 lbf ft)

Input variable

Measured variable Level of liquids

Min. dielectric figure of the medium

- Cable probes $\epsilon_r \geq 1.6$
- Rod probes $\epsilon_r \geq 1.6$

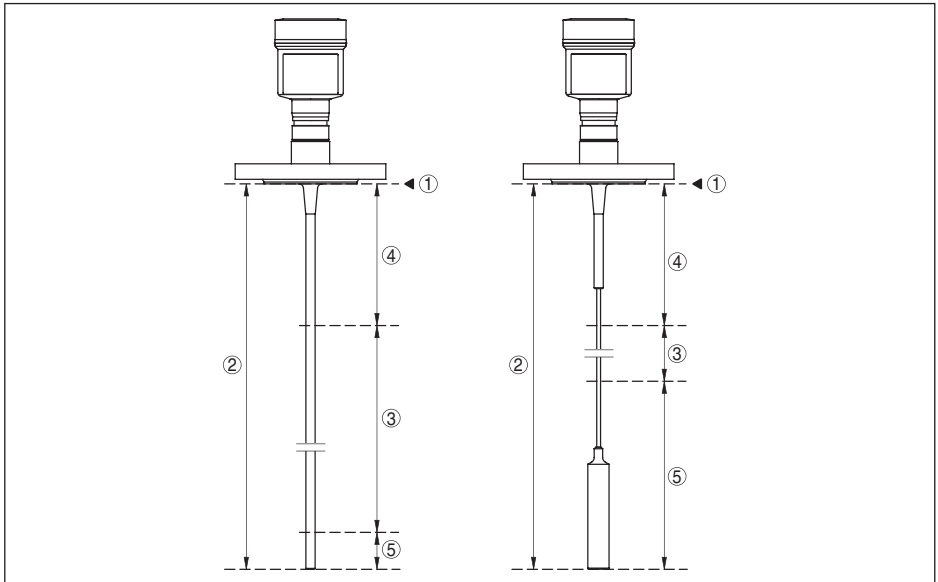

Fig. 35: Measuring ranges - VEGAFLEX 83

- 1 Reference plane
- 2 Probe length L
- 3 Measuring range (default setting refers to the measuring range in water)
- 4 Upper dead band (see diagrams under Accuracy - grey section)
- 5 Lower dead band (see diagrams under Accuracy - grey section)

Output variable

Output signal 4 ... 20 mA/HART
Fulfilled HART specification 7
Signal resolution 0.3 μ A

Failure signal current output (adjustable)	Last valid measured value, $\geq 21.0 \text{ mA}$, $\leq 3.6 \text{ mA}$
Max. output current	22 mA
Starting current	$\leq 3.6 \text{ mA}$; $\leq 10 \text{ mA}$ for 5 ms after switching on
Load	see load diagram under Power supply
Damping (63 % of the input variable), adjustable	0 ... 999 s
HART output values according to HART 7 (default setting) ¹⁾	
– PV (Primary Value)	Linearised percentage value, level
– SV (Secondary Value)	Distance to the level
– TV (Third Value)	Measurement certainty, level
– QV (Fourth Value)	Electronics temperature
Indication value - Indicating and adjustment module ²⁾	
– Displayed value 1	Filling height - level
– Displayed value 2	Electronics temperature
Resolution, digital	< 1 mm (0.039 in)

Accuracy (according to DIN EN 60770-1)

Process reference conditions according to DIN EN 61298-1

– Temperature	+18 ... +30 °C (+64 ... +86 °F)
– Relative humidity	45 ... 75 %
– Air pressure	+860 ... +1060 mbar/+86 ... +106 kPa (+12.5 ... +15.4 psig)

Installation reference conditions

– Min. distance to installations	> 500 mm (19.69 in)
– Vessel	metallic, $\varnothing 1 \text{ m}$ (3.281 ft), centric installation, process fitting flush with the vessel ceiling
– Medium	Water/Oil (dielectric constant ~ 2.0)
– Installation	Probe end does not touch the vessel bottom

Sensor parameter adjustment Gating out of false signals carried out

Deviation³⁾⁴⁾ see diagrams

¹⁾ The output values can be assigned individually

²⁾ The indication values can be assigned individually

³⁾ Depending on the installation conditions, there can be deviations which can be rectified with an adaptation of the adjustment or a change of the measured value offset in the DTM service mode

⁴⁾ The dead bands can be optimized by a false signal suppression.

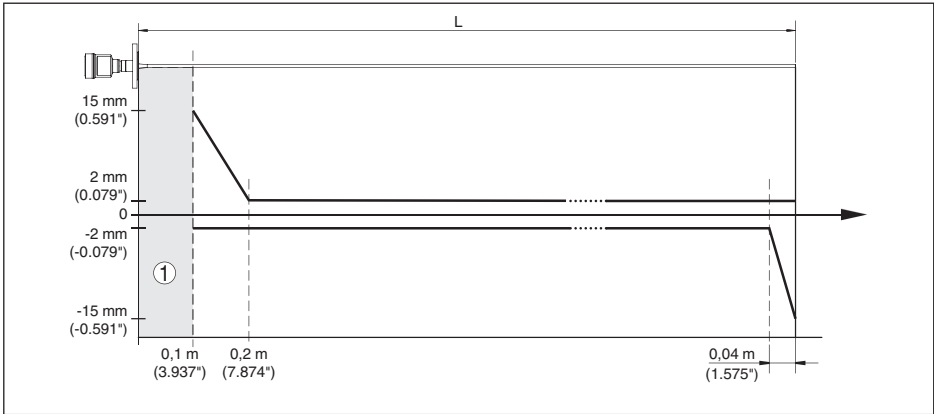

Fig. 36: Deviation VEGAFLEX 83 in rod version (coated) in water

- 1 Dead band - no measurement possible in this area
- L Probe length

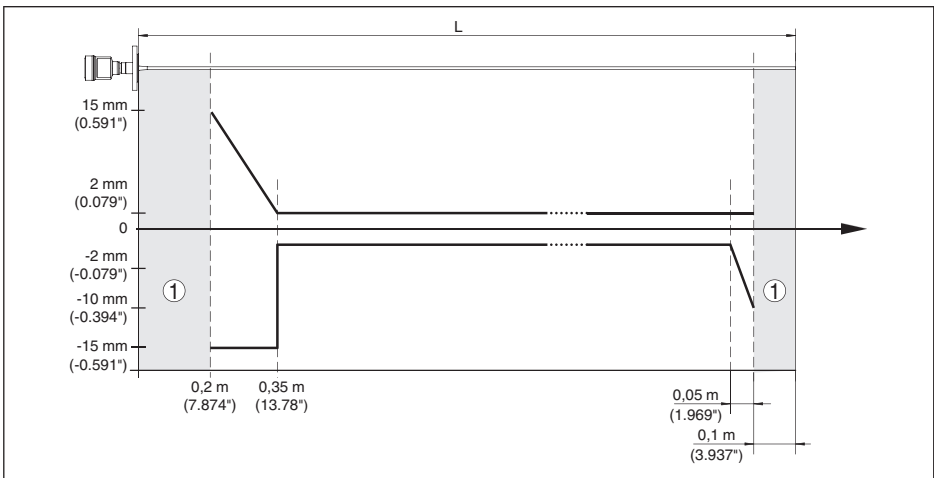

Fig. 37: Deviation VEGAFLEX 83 in rod version (coated) in oil

- 1 Dead band - no measurement possible in this area
- L Probe length

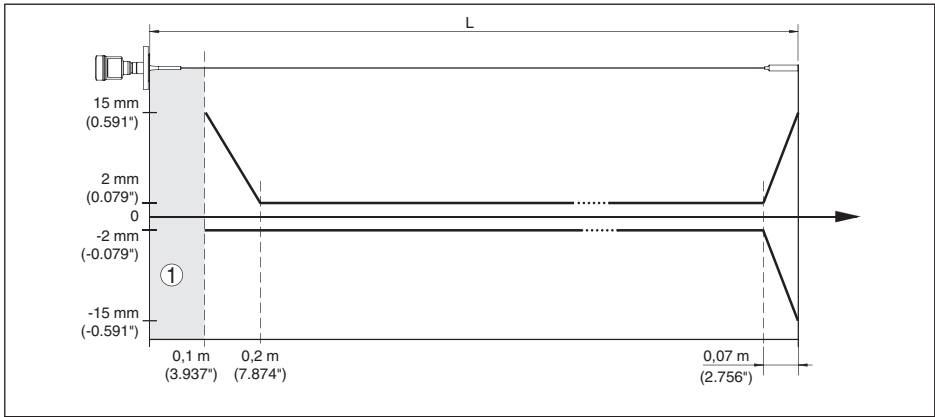

Fig. 38: Deviation VEGAFLEX 83 in cable version (coated) in water

- 1 Dead band - no measurement possible in this area
- L Probe length

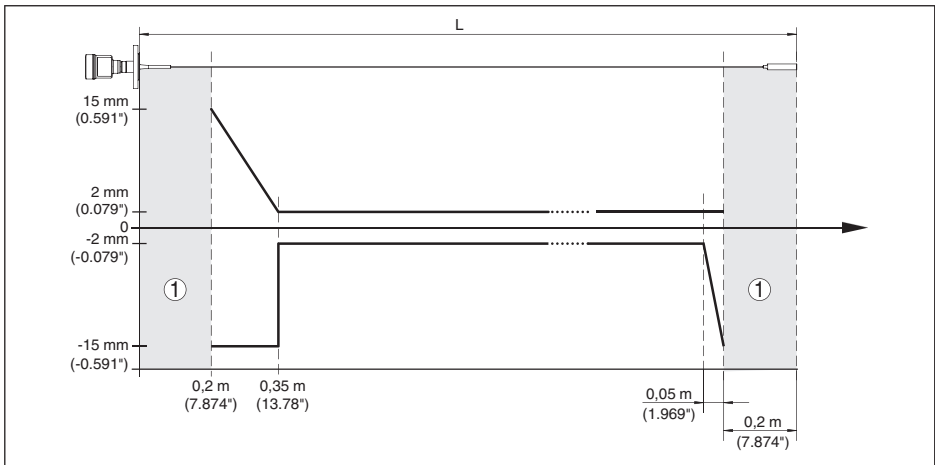

Fig. 39: Deviation VEGAFLEX 83 in cable version (coated) in oil

- 1 Dead band - no measurement possible in this area
- L Probe length

Reproducibility $\leq \pm 1$ mm

Variables influencing measurement accuracy

Specifications apply to the HART signal and the current output

Temperature drift - Digital output ± 3 mm/10 K relating to the max. measuring range or max. 10 mm (0.394 in)

Additional deviation through strong, high frequency electromagnetic fields acc. to EN 61326 $< \pm 10$ mm ($< \pm 0.394$ in)

41834-EN-120726

Specifications apply also to the current output

Temperature drift - Current output	$\pm 0.03\%$ /10 K relating to the 16 mA span max. $\pm 0.3\%$
Deviation on the current output by analogue/digital conversion	$< \pm 15\ \mu\text{A}$
Deviation on the current output due to strong, high frequency electromagnetic fields acc. to EN 61326	$< \pm 150\ \mu\text{A}$

Characteristics and performance data

Measuring cycle time	500 ms
Step response time ⁵⁾	$\leq 3\ \text{s}$
Tracking speed of the measuring window max.	1 m/min

Ambient conditions

Ambient, storage and transport temperature -40 ... +80 °C (-40 ... +176 °F)

Process conditions

For the process conditions, please also note the specifications on the type label. The lowest value always applies.

The measurement error from the process conditions is in the specified pressure and temperature range of below 1 %.

Process pressure	-1 ... +40 bar/-100 ... +4000 kPa (-14.5 ... +580 psig), depending on the process fitting
Vessel pressure relating to the flange nominal stage	see supplementary instructions manual " <i>Flanges according to DIN-EN-ASME-JIS</i> "
Process temperature (thread or flange temperature)	
- FKM (SHS FPM 70C3 GLT)	-40 ... +150 °C (-40 ... +302 °F)
- EPDM (A+P 75.5/KW75F)	-40 ... +150 °C (-40 ... +302 °F)

⁵⁾ Time span after a sudden measuring distance change by max. 0.5 m in liquid applications, max 2 m with bulk solids applications, until the output signal has taken for the first time 90 % of the final value (IEC 61298-2).

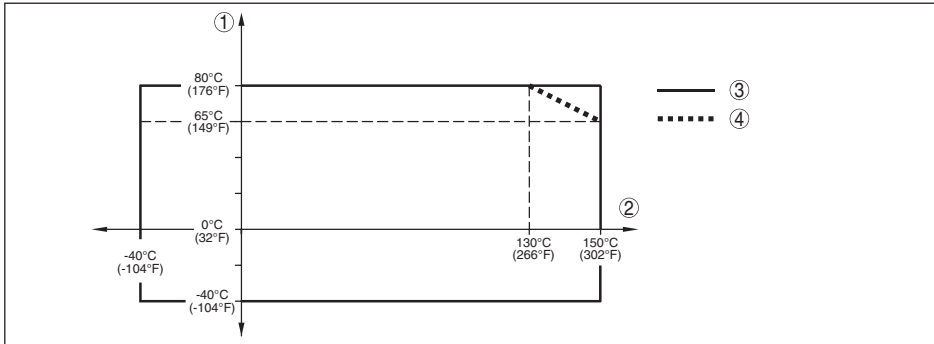

Fig. 40: Ambient temperature - process temperature, standard version

- 1 Ambient temperature
- 2 Process temperature (depending on the seal material)
- 3 Maximum permissible temperature - standard
- 4 Limited temperature range - plastic housing and stainless steel housing, electropolished

Vibration resistance

- Instrument housing 4 g at 5 ... 200 Hz according to EN60068-2-6 (vibration with resonance)
- Rod probe 1 g with 5 ... 200 Hz according EN60068-2-6 (vibration at resonance) with rod length 50 cm (19.69 in)

Shock resistance

- Instrument housing 100 g, 6 ms according to EN60068-2-27 (mechanical shock)
- Rod probe 25 g, 6 ms according to EN60068-2-27 (mechanical shock) with rod length 50 cm (19.69 in)

Electromechanical data - version IP 66/IP 67 and IP 66/IP 68; 0.2 bar

Options of the cable entry

- Cable gland M20 x 1.5 (cable: \varnothing 5 ... 9 mm)
- Cable entry 1/2 NPT
- Blind stopper M20 x 1.5; 1/2 NPT
- Closing cap M20 x 1.5; 1/2 NPT

Plug options

- Signal circuit M12 x 1, according to ISO 4400, Harting HAN, 7/8" FF
- Indication circuit M12 x 1

Wire cross-section (spring-loaded terminals)

- Massive wire, cord 0.2 ... 2.5 mm² (AWG 24 ... 14)
- Stranded wire with end sleeve 0.2 ... 1.5 mm² (AWG 24 ... 16)

Electromechanical data - version IP 66/IP 68 (1 bar)

Options of the cable entry

41834-EN-120726

– Cable gland with integrated connection cable	M20 x 1.5 (cable: ø 5 ... 9 mm)
– Cable entry	½ NPT
– Blind stopper	M20 x 1.5; ½ NPT

Connection cable

– Wire cross-section	0.5 mm ² (AWG 20)
– Wire resistance	< 0.036 Ω/m
– Tensile strength	< 1200 N (270 lbf)
– Standard length	5 m (16.4 ft)
– Max. length	180 m (590.6 ft)
– Min. bending radius	25 mm (0.984 in) with 25 °C (77 °F)
– Diameter approx.	8 mm (0.315 in)
– Colour - Non-Ex version	Blue
– Colour - Ex-version	Blue

Indicating and adjustment module

Voltage supply and data transmission	through the sensor
Indication	LC display in dot matrix
Measured value indication	
– Number of digits	5
– Size of digits	W x H = 7 x 13 mm
Adjustment elements	4 keys
Protection rating	
– unassembled	IP 20
– mounted into the sensor without cover	IP 40
Materials	
– Housing	ABS
– Inspection window	Polyester foil

Integrated clock

Date format	Day.Month.Year
Time format	12 h/24 h
Time zone Ex factory	CET

Measurement electronics temperature

Resolution	1 °C (1.8 °F)
Accuracy	±1 °C (1.8 °F)

Voltage supply

Operating voltage

- Non-Ex instrument, Ex-d instrument 9.6 ... 35 V DC
- Ex-ia instrument 9.6 ... 30 V DC
- Ex-d-ia instrument 14 ... 35 V DC
- Ex-d-ia instrument with ship approval 15 ... 35 V DC

Operating voltage with illuminated indicating and adjustment module

- Non-Ex instrument, Ex-d instrument 16 ... 35 V DC
- Ex-ia instrument 16 ... 30 V DC
- Ex-d-ia instrument 20 ... 35 V DC

Interpolation protection Available

Permissible residual ripple - Non-Ex, Ex-ia instrument

- for $9.6 \text{ V} < U_N < 14 \text{ V}$ $\leq 0.7 V_{\text{eff}}$ (16 ... 400 Hz)
- for $18 \text{ V} < U_N < 36 \text{ V}$ $\leq 1.0 V_{\text{eff}}$ (16 ... 400 Hz)

Permissible residual ripple - Ex-d-ia instrument

- for $18 \text{ V} < U_N < 35 \text{ V}$ $\leq 1 V_{\text{eff}}$ (16 ... 400 Hz)

Load see diagram

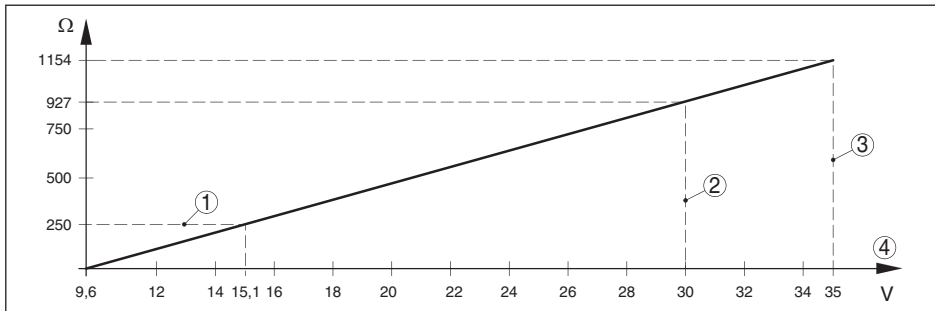

Fig. 41: Voltage diagram

- 1 HART load
- 2 Voltage limit non-Ex instrument, Ex-d-ia instrument
- 3 Voltage limit non-Ex/Ex-d instrument
- 4 Operating voltage

Electrical protective measures

Protection, depending on housing version

- Plastic housing IP 66/IP 67
- Aluminium housing, stainless steel housing - investment casting, stainless steel housing - electro-polished IP 66/IP 68 (0.2 bar)⁶⁾
- Aluminium and stainless housing, investment casting (optionally available) IP 66/IP 68 (1 bar)

Overvoltage category III

⁶⁾ The prerequisites for maintaining the protection rating are a suitable cable as well as correct mounting.

Approvals

Instruments with approvals can have different technical data depending on the version.

That's why the associated approval documents of these instruments have to be carefully noted. They are part of the delivery or can be downloaded under www.vega.com and "VEGA Tools" as well as under "[Downloads](#)" and "[Approvals](#)".

11.2 Dimensions

The following dimensional drawings represent only an extract of the possible versions. Detailed dimensional drawings can be downloaded on www.vega.com/downloads and "[Drawings](#)".

Plastic housing

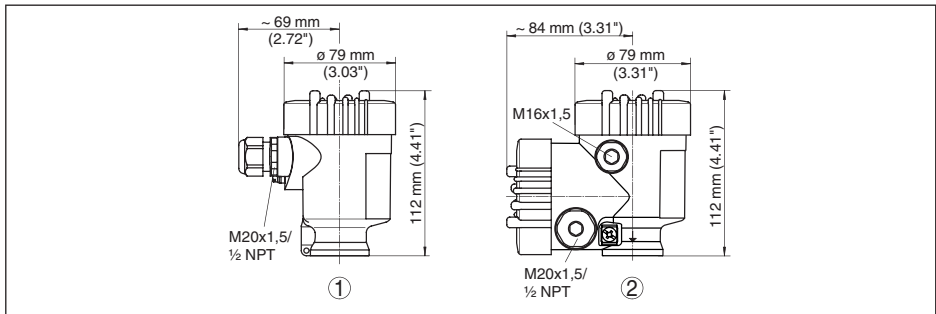

Fig. 42: Housing versions in protection IP 66/IP 68 (0.2 bar) - with integrated indicating and adjustment module the housing is 9 mm/0.35 in higher

- 1 Single chamber version
- 2 Double chamber version

Aluminium housing

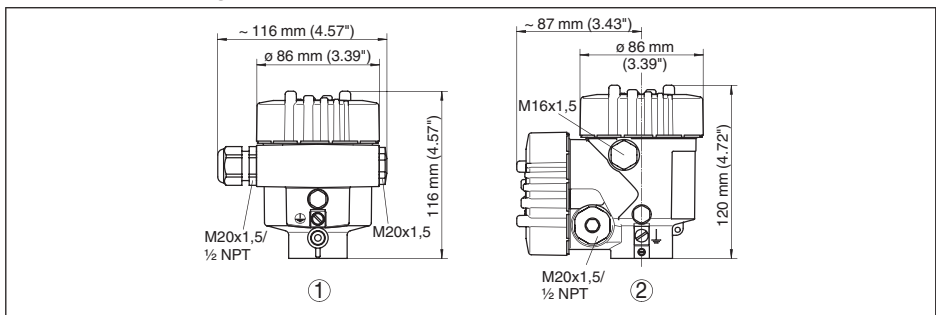

Fig. 43: Housing versions in protection IP 66/IP 68 (0.2 bar) - with integrated indicating and adjustment module the housing is 9 mm/0.35 in higher

- 1 Single chamber version
- 2 Double chamber version

Aluminium housing in protection rating IP 66/IP 68 (1 bar)

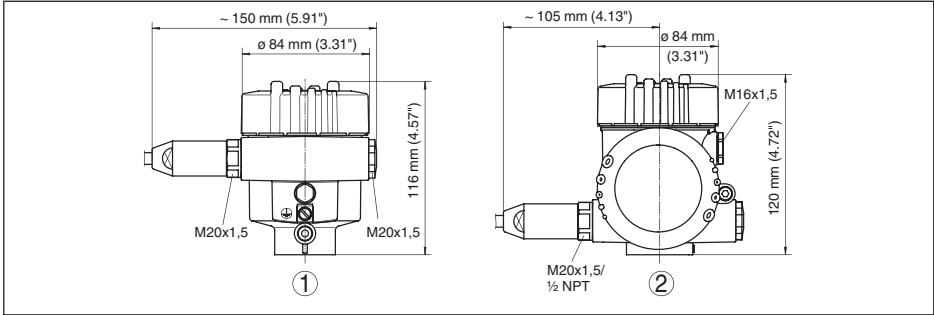

Fig. 44: Housing versions in protection IP 66/IP 68 (1 bar) - with integrated indicating and adjustment module the housing is 9 mm/0.35 in higher

- 1 Single chamber version
- 2 Double chamber version

Stainless steel housing

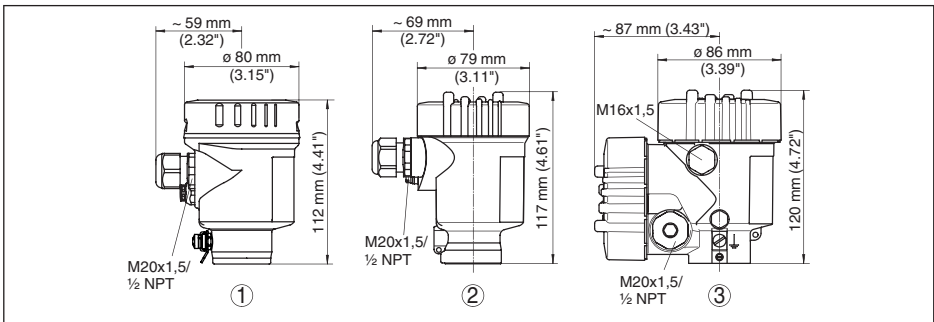

Fig. 45: Housing versions in protection IP 66/IP 68 (0.2 bar) - with integrated indicating and adjustment module the housing is 9 mm/0.35 in higher

- 1 Single chamber version, electropolished
- 2 Single chamber version, precision casting
- 3 Double chamber version, precision casting

Stainless steel housing in protection rating IP 66/IP 68, 1 bar

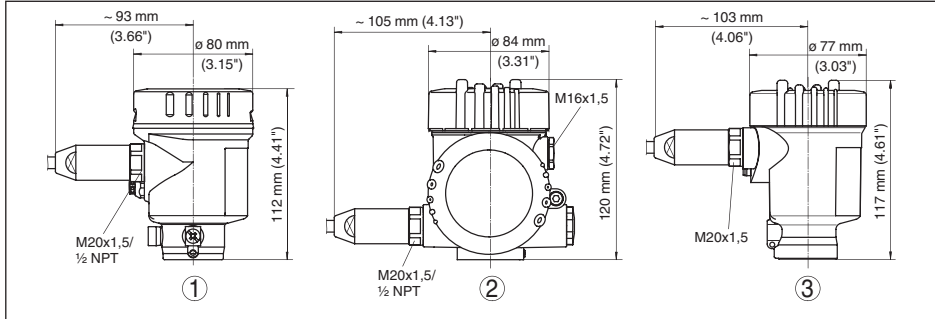

Fig. 46: Housing versions in protection IP 66/IP 68 (1 bar) - with integrated indicating and adjustment module the housing is 9 mm/0.35 in higher

- 1 Single chamber version, electropolished
- 2 Single chamber version, precision casting
- 3 Double chamber version, precision casting

VEGAFLEX 83, cable version \varnothing 4 mm (0.157 in) - PFA coated

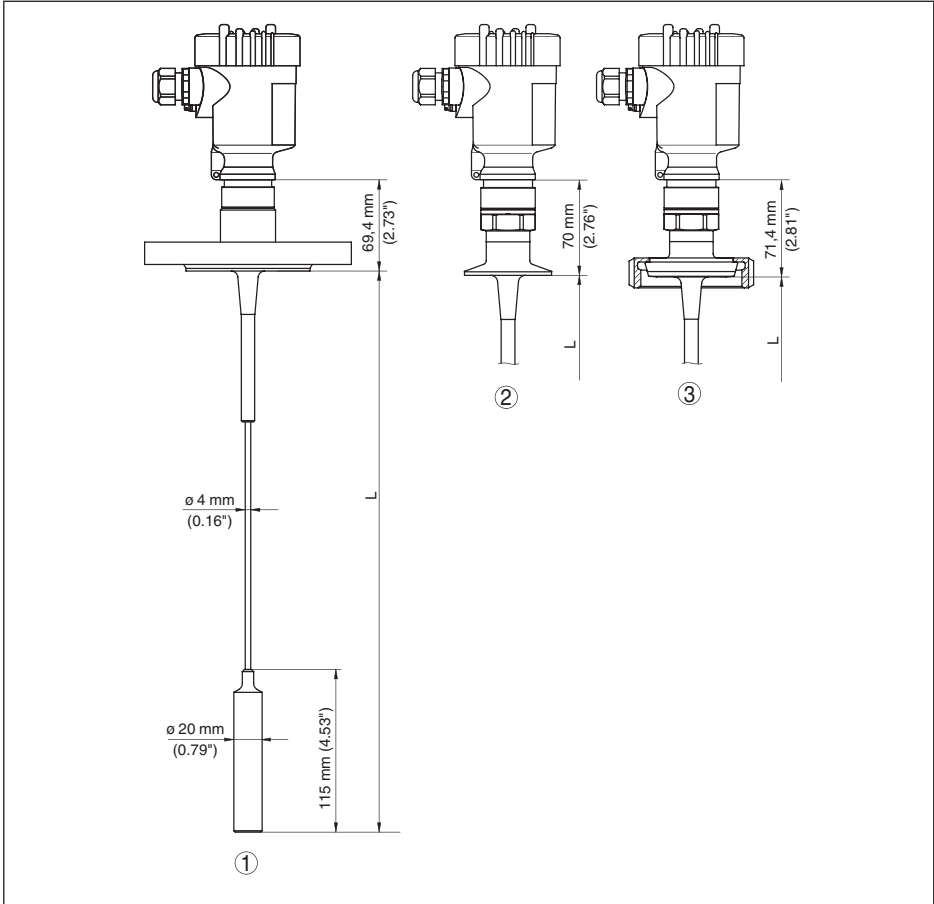

Fig. 47: VEGAFLEX 83, cable version with gravity weight

- L Sensor length, see chapter "Technical data"
- 1 Cable version, \varnothing 4 mm (0.157 in) with flange
- 2 Cable version with Clamp
- 3 Cable version with bolting

VEGAFLEX 83, rod version \varnothing 10 mm (0.394 in) - PFA coated

Fig. 48: VEGAFLEX 83, rod version

- L Sensor length, see chapter "Technical data"
 1 Rod version, \varnothing 10 mm (0.394 in) with flange
 2 Rod version with Clamp
 3 Rod version with bolting

11.3 Industrial property rights

Линии продукции фирмы ВЕГА защищаются по всему миру правами на интеллектуальную собственность. Дальнейшую информацию смотрите на сайте _____

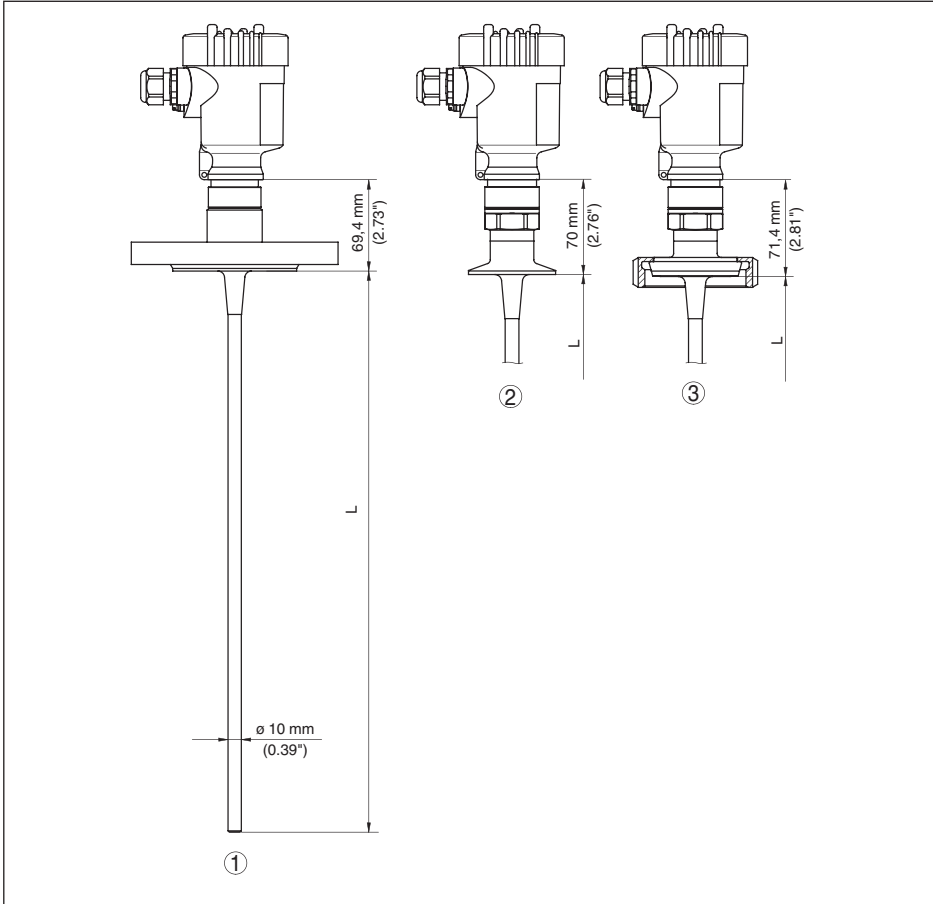
VEGA系列产品在全球享有知识产权保护。

进一步信息请参见网站<_____>。

11.4 Trademark

All the brands as well as trade and company names used are property of their lawful proprietor/originator.

INDEX

A

Accessories

- External indicating and adjustment unit 10, 11
- External radio unit 11
- Flanges 11
- Indicating and adjustment module 10
- Interface adapter 10
- Protective cover 11

Adjustment

- Max. adjustment 30, 31
- Min. adjustment 31

Adjustment system 27

Application area 8

Applications 29, 30

B

Backlight 36

C

Cable entry 18

Calibration date 43

Check signal 57

Connection cable 18

Connection procedure 19

Connection technology 19

Copy sensor settings 41

Current output, adjustment 34

Current output Min./Max. 34

Current output, size 34

Curve indication

- Echo curve 38

D

Damping 32

Date/Time 40

DD (Device Description) 52

Default value 40

Deviation 58

E

Echo curve memory 53

Echo curve of the setup 39

EDD (Enhanced Device Description) 52

Electronics and connection compartment, single chamber housing 21

Electronics compartment, double chamber housing 21

Electronics compartment with Ex-d double chamber housing 23

Error messages 54

Event memory 53

F

Factory calibration date 43

False signal suppression 35

Fault rectification 57

Functional principle 8

G

Gas phase 30

Grounding 18

H

HART address 42

HART resistor 45

HART variables 35

I

Inflowing medium 15

Installation position 13

Instrument version 43

K

Key function 26

L

Language 36

Linearisation 32

Lock operation 28

M

Main menu 27

Meas. reliability 37

Measured value indication 36

Measured value memory 53

Measurement loop name 28

Moisture 13

N

NAMUR NE 107

– Failure 55

– Function check 56

– Maintenance 56

– Out of specification 56

P

Packaging 10

Peak value 37, 38

PIN 39

Potential equalisation 19

Probe length 28
Probe type 42
Product type 29

R

Read out info 43
Repair 61
Replacement parts
– Electronics module 11
– Indicating and adjustment module with heating 11
– Rod extension 11
– Spacer 12
Reset 40

S

Scaling measured value 33, 34
Sensor characteristics 43
Sensor status 37
Service hotline 60
Shielding 18
Simulation 38
Special parameters 42
Status messages 54
Storage 10

T

Type label 7

U

Units 28

V

Voltage supply 18

Printing date:

VEGA

All statements concerning scope of delivery, application, practical use and operating conditions of the sensors and processing systems correspond to the information available at the time of printing.

Subject to change without prior notice

© VEGA Grieshaber KG, Schiltach/Germany 2012



41834-EN-120726

VEGA Grieshaber KG
Am Hohenstein 113
77761 Schiltach
Germany

Phone +49 7836 50-0
Fax +49 7836 50-201
E-mail: info.de@vega.com
www.vega.com