

Operating Instructions

Radar sensor for continuous level
measurement of bulk solids

VEGAPULS 69

4 ... 20 mA/HART - four-wire



Document ID: 47249



VEGA

Contents

1	About this document	
1.1	Function	4
1.2	Target group	4
1.3	Symbols used.....	4
2	For your safety	
2.1	Authorised personnel	5
2.2	Appropriate use.....	5
2.3	Warning about incorrect use.....	5
2.4	General safety instructions	5
2.5	CE conformity.....	6
2.6	NAMUR recommendations	6
2.7	Radio license for Europe	6
2.8	Environmental instructions	7
3	Product description	
3.1	Configuration.....	8
3.2	Principle of operation.....	9
3.3	Packaging, transport and storage.....	10
3.4	Accessories and replacement parts	10
4	Mounting	
4.1	General instructions	13
4.2	Mounting versions, plastic horn antenna	13
4.3	Mounting preparations, mounting strap	16
4.4	Mounting instructions	16
5	Connecting to power supply	
5.1	Preparing the connection	27
5.2	Connection.....	28
5.3	Wiring plan, double chamber housing	29
5.4	Double chamber housing with DIS-ADAPT	31
5.5	Switch-on phase.....	31
6	Set up with the display and adjustment module	
6.1	Insert display and adjustment module	33
6.2	Adjustment system	34
6.3	Measured value indication - Selection national language	34
6.4	Parameter adjustment - Quick setup	35
6.5	Parameter adjustment - Extended adjustment.....	36
6.6	Saving the parameter adjustment data.....	50
7	Setup with PACTware	
7.1	Connect the PC.....	52
7.2	Parameter adjustment	53
7.3	Saving the parameter adjustment data.....	54
8	Set up with other systems	
8.1	DD adjustment programs	55
8.2	Field Communicator 375, 475	55
9	Diagnosis, asset management and service	
9.1	Maintenance	56

9.2	Measured value and event memory	56
9.3	Asset Management function.....	57
9.4	Rectify faults.....	61
9.5	Exchanging the electronics module.....	64
9.6	Software update	65
9.7	How to proceed if a repair is needed	65
10	Dismount	
10.1	Dismounting steps.....	66
10.2	Disposal	66
11	Supplement	
11.1	Technical data	67
11.2	Radio astronomy stations.....	74
11.3	Dimensions	75



Safety instructions for Ex areas

Please note the Ex-specific safety information for installation and operation in Ex areas. These safety instructions are part of the operating instructions manual and come with the Ex-approved instruments.

Editing status:2014-07-07

1 About this document

1.1 Function

This operating instructions manual provides all the information you need for mounting, connection and setup as well as important instructions for maintenance and fault rectification. Please read this information before putting the instrument into operation and keep this manual accessible in the immediate vicinity of the device.

1.2 Target group

This operating instructions manual is directed to trained specialist personnel. The contents of this manual should be made available to these personnel and put into practice by them.

1.3 Symbols used



Information, tip, note

This symbol indicates helpful additional information.



Caution: If this warning is ignored, faults or malfunctions can result.



Warning: If this warning is ignored, injury to persons and/or serious damage to the instrument can result.



Danger: If this warning is ignored, serious injury to persons and/or destruction of the instrument can result.



Ex applications

This symbol indicates special instructions for Ex applications.



List

The dot set in front indicates a list with no implied sequence.



Action

This arrow indicates a single action.



Sequence of actions

Numbers set in front indicate successive steps in a procedure.



Battery disposal

This symbol indicates special information about the disposal of batteries and accumulators.

2 For your safety

2.1 Authorised personnel

All operations described in this operating instructions manual must be carried out only by trained specialist personnel authorised by the plant operator.

During work on and with the device the required personal protective equipment must always be worn.

2.2 Appropriate use

VEGAPULS 69 is a sensor for continuous level measurement.

You can find detailed information about the area of application in chapter "*Product description*".

Operational reliability is ensured only if the instrument is properly used according to the specifications in the operating instructions manual as well as possible supplementary instructions.

2.3 Warning about incorrect use

Inappropriate or incorrect use of the instrument can give rise to application-specific hazards, e.g. vessel overflow or damage to system components through incorrect mounting or adjustment.

2.4 General safety instructions

This is a state-of-the-art instrument complying with all prevailing regulations and guidelines. The instrument must only be operated in a technically flawless and reliable condition. The operator is responsible for the trouble-free operation of the instrument.

During the entire duration of use, the user is obliged to determine the compliance of the necessary occupational safety measures with the current valid rules and regulations and also take note of new regulations.

The safety instructions in this operating instructions manual, the national installation standards as well as the valid safety regulations and accident prevention rules must be observed by the user.

For safety and warranty reasons, any invasive work on the device beyond that described in the operating instructions manual may be carried out only by personnel authorised by the manufacturer. Arbitrary conversions or modifications are explicitly forbidden.

The safety approval markings and safety tips on the device must also be observed.

Depending on the instrument version, the emitting frequencies are in the C or K band range. The low emitting frequencies are far below the internationally approved limit values. When used correctly, there is no danger to health.

2.5 CE conformity

The device fulfills the legal requirements of the applicable EC guidelines. By affixing the CE marking, we confirm successful testing of the product.

You can find the CE Certificate of Conformity in the download section of our homepage.

Electromagnetic compatibility

Instruments in four-wire or Ex-d-ia version are designed for use in an industrial environment. Nevertheless, electromagnetic interference from electrical conductors and radiated emissions must be taken into account, as is usual with class A instruments according to EN 61326-1. If the instrument is used in a different environment, the electromagnetic compatibility to other instruments must be ensured by suitable measures.

2.6 NAMUR recommendations

NAMUR is the automation technology user association in the process industry in Germany. The published NAMUR recommendations are accepted as the standard in field instrumentation.

The device fulfills the requirements of the following NAMUR recommendations:

- NE 21 – Electromagnetic compatibility of equipment
- NE 43 – Signal level for malfunction information from measuring transducers
- NE 53 – Compatibility of field devices and display/adjustment components
- NE 107 – Self-monitoring and diagnosis of field devices

For further information see www.namur.de.

2.7 Radio license for Europe

The instrument meets the LPR (Level Probing Radar) radio standard EN 302729-1/2.

It is approved for unrestricted use inside and outside of closed vessels in countries of the EU and EFTA that have implemented this standard.

For operation outside of closed vessels, the following conditions must be fulfilled:

- The installation must be carried out by trained qualified personnel
- The instrument must be stationary mounted and the antenna directed vertically downward
- The mounting location must be at least 4 km away from the radio astronomy stations, unless special permission was granted by the responsible national approval authority
- When installed within 4 to 40 km of a radio astronomy station, the instrument must not be mounted higher than 15 m above the ground.

You can find a list with the respective radio astronomy stations in chapter "*Supplement*".

2.8 Environmental instructions

Protection of the environment is one of our most important duties. That is why we have introduced an environment management system with the goal of continuously improving company environmental protection. The environment management system is certified according to DIN EN ISO 14001.

Please help us fulfill this obligation by observing the environmental instructions in this manual:

- Chapter "*Packaging, transport and storage*"
- Chapter "*Disposal*"

3 Product description

3.1 Configuration

Type label

The type label contains the most important data for identification and use of the instrument:

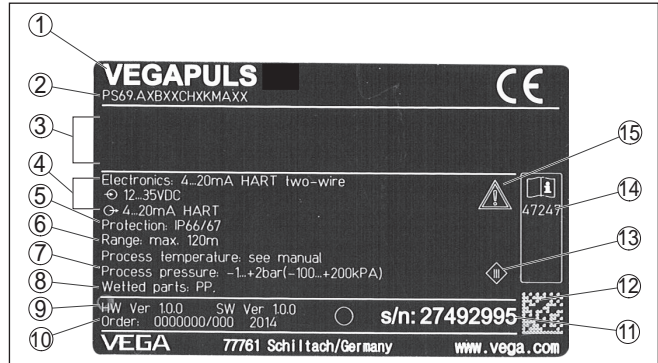

Fig. 1: Layout of the type label (example)

- 1 Instrument type
- 2 Product code
- 3 Approvals
- 4 Power supply and signal output, electronics
- 5 Protection rating
- 6 Measuring range
- 7 Process and ambient temperature, process pressure
- 8 Material, wetted parts
- 9 Hardware and software version
- 10 Order number
- 11 Serial number of the instrument
- 12 Data-Matrix-Code for Smartphone-App
- 13 Symbol of the device protection class
- 14 ID numbers, instrument documentation
- 15 Reminder to observe the instrument documentation
- 16 Notified authority for CE marking
- 17 Approval directive

Serial number - Instrument search

The type label contains the serial number of the instrument. With it you can find the following instrument data on our homepage:

- Product code (HTML)
- Delivery date (HTML)
- Order-specific instrument features (HTML)
- Operating instructions and quick setup guide at the time of shipment (PDF)
- Order-specific sensor data for an electronics exchange (XML)
- Test certificate (PDF) - optional

Go to www.vega.com, "VEGA Tools" and "Instrument search". Enter the serial number.

Alternatively, you can access the data via your smartphone:

- Download the smartphone app "VEGA Tools" from the "Apple App Store" or the "Google Play Store"
- Scan the Data Matrix code on the type label of the instrument or
- Enter the serial number manually in the app

Scope of this operating instructions manual

This operating instructions manual applies to the following instrument versions:

- Hardware version from 1.0.0
- Software version from 1.0.1

Scope of delivery

The scope of delivery encompasses:

- Radar sensor
- Documentation
 - Quick setup guide VEGAPULS 69
 - Instructions for optional instrument features
 - Ex-specific "Safety instructions" (with Ex versions)
 - if necessary, further certificates
- DVD "Software & Documents", containing
 - Operating instructions
 - Safety instructions
 - PACTware/DTM-Collection
 - Driver software



Information:

In this operating instructions manual, the optional instrument features are described. The respective scope of delivery results from the order specification.

3.2 Principle of operation

Application area

The VEGAPULS 69 is a radar sensor for continuous level measurement of bulk solids even under the most difficult process conditions and in wide measuring ranges.

It is ideal for use in high, slender silos, with poorly reflective bulk solids such as flyash, plastic granules or wood chips as well as strong false reflections by installations. This is made possible thanks to the functional principle, a distance measurement through frequency shifting with a particularly small antenna opening angle.

The instrument is available with different antenna systems and equipment for virtually all applications and processes:

- Plastic horn antenna or metal jacketed lens antenna
- Optional or integrated rinsing air connection
- Swivelling holder with seal against the process

Functional principle

The instrument emits a continuous radar signal via its antenna. This signal is frequency modulated with a sawtooth form. The emitted signal is reflected by the medium and received by the antenna as echo.

The frequency of the received signal always deviates from the actual emitting frequency. The frequency difference is proportional to the distance and thus to the filling height. This difference is calculated

via special algorithms in the sensor electronics. The determined filling height is then converted into a corresponding output signal and outputted as the measured value.

3.3 Packaging, transport and storage

Packaging

Your instrument was protected by packaging during transport. Its capacity to handle normal loads during transport is assured by a test based on ISO 4180.

The packaging of standard instruments consists of environment-friendly, recyclable cardboard. For special versions, PE foam or PE foil is also used. Dispose of the packaging material via specialised recycling companies.

Transport

Transport must be carried out in due consideration of the notes on the transport packaging. Nonobservance of these instructions can cause damage to the device.

Transport inspection

The delivery must be checked for completeness and possible transit damage immediately at receipt. Ascertained transit damage or concealed defects must be appropriately dealt with.

Storage

Up to the time of installation, the packages must be left closed and stored according to the orientation and storage markings on the outside.

Unless otherwise indicated, the packages must be stored only under the following conditions:

- Not in the open
 - Dry and dust free
 - Not exposed to corrosive media
 - Protected against solar radiation
 - Avoiding mechanical shock and vibration
- Storage and transport temperature see chapter "*Supplement - Technical data - Ambient conditions*"
 - Relative humidity 20 ... 85 %

Storage and transport temperature

3.4 Accessories and replacement parts

PLICSCOM

The display and adjustment module PLICSCOM is used for measured value indication, adjustment and diagnosis. It can be inserted into the sensor or the external display and adjustment unit and removed at any time.

You can find further information in the operating instructions "*Display and adjustment module PLICSCOM*" (Document-ID 27835).

VEGACONNECT

The interface adapter VEGACONNECT enables the connection of communication-capable instruments to the USB interface of a PC. For parameter adjustment of these instruments, the adjustment software PACTware with VEGA-DTM is required.

You can find further information in the operating instructions "*Interface adapter VEGACONNECT*" (Document-ID 32628).

VEGADIS 81	<p>The VEGADIS 81 is an external display and adjustment unit for VEGA plics® sensors.</p> <p>For sensors with double chamber housing the interface adapter "<i>DIS-ADAPT</i>" is also required for VEGADIS 81.</p> <p>You can find further information in the operating instructions "<i>VEGADIS 81</i>" (Document-ID 43814).</p>
DIS-ADAPT	<p>The adapter "<i>DIS-ADAPT</i>" is an accessory part for sensors with double chamber housings. It enables the connection of VEGADIS 81 to the sensor housing via an M12 x 1 plug.</p> <p>You can find further information in the supplementary instructions "<i>Adapter DISADAPT</i>" (Document-ID 45250).</p>
VEGADIS 82	<p>VEGADIS 82 is suitable for measured value indication and adjustment of sensors with HART protocol. It is looped into the 4 ... 20 mA/HART signal cable.</p> <p>You can find further information in the operating instructions "<i>VEGADIS 82</i>" (Document-ID 45300).</p>
PLICSMOBILE T61	<p>PLICSMOBILE T61 is an external GSM/GPRS radio unit for transmission of measured values and for remote parameter adjustment of plics® sensors. Adjustment is carried out via PACTware/DTM and the integrated USB connection.</p> <p>You can find further information in the supplementary instructions "<i>PLICSMOBILE T61</i>" (Document-ID 37700).</p>
Protective cap	<p>The protective cover protects the sensor housing against soiling and intense heat from solar radiation.</p> <p>You will find additional information in the supplementary instructions manual "<i>Protective cover</i>" (Document-ID 34296).</p>
Flanges	<p>Screwed flanges are available in different versions according to the following standards: DIN 2501, EN 1092-1, BS 10, ANSI B 16.5, JIS B 2210-1984, GOST 12821-80.</p> <p>You can find additional information in the supplementary instructions manual "<i>Flanges according to DIN-EN-ASME-JIS</i>" (Document-ID 31088).</p>
Flanges with plastic horn antenna	<p>For mounting the instrument with plastic horn antenna to a socket, two flange versions are available: the combi compression flange and the adapter flange</p> <p>You can find additional information in chapter "<i>Mounting</i>" of this operating instruction.</p>
Mounting strap with plastic horn antenna	<p>A mounting strap is available for mounting the instrument with plastic horn antenna to the wall or ceiling.</p> <p>You can find additional information in chapter "<i>Mounting</i>" of this operating instruction.</p>

Electronics module

Electronics module "VEGAPULS series 60" is a replacement part for radar sensors of VEGAPULS series 60. A different version is available for each type of signal output.

You can find further information in the operating instructions "*Electronics module VEGAPULS series 60*" (Document-ID 36801).

Supplementary electronics 4 ... 20 mA/HART - four-wire

The supplementary electronics is a replacement part for the following sensors with 4 ... 20 mA/HART - two-wire:

- VEGAPULS series 60
- VEGAFLEX 80 series
- VEGABAR series 80

You can find further information in the operating instructions "*Supplementary electronics for 4 ... 20 mA/HART - four-wire*" (Document-ID 42766).

4 Mounting

4.1 General instructions

Protection against moisture

Protect your instrument against moisture ingress through the following measures:

- Use the recommended cable (see chapter "Connecting to power supply")
- Tighten the cable gland
- Loop the connection cable downward in front of the cable gland

This applies particularly to:

- Outdoor mounting
- Installations in areas where high humidity is expected (e.g. through cleaning processes)
- Installations on cooled or heated vessels

Suitability for the process conditions

Make sure that all parts of the instrument exposed to the process are suitable for the existing process conditions.

These are mainly:

- Active measuring component
- Process fitting
- Process seal

Process conditions are particularly:

- Process pressure
- Process temperature
- Chemical properties of the medium
- Abrasion and mechanical influences

You can find detailed information on the process conditions in chapter "Technical data" as well as on the type label.

4.2 Mounting versions, plastic horn antenna

Mounting strap

The optional mounting strap allows simple mounting of the instrument on a wall, ceiling or boom. Especially with open vessels, this is a simple and effective way to align the sensor to the surface of the bulk solid material.

The following versions are available:

- Length 300 mm
- Length 170 mm

Mounting strap - Ceiling mounting

The instrument is normally mounted with a strap vertically on the ceiling.

This allows swivelling the sensor up to 180° for optimal orientation and rotating for optimal connection.

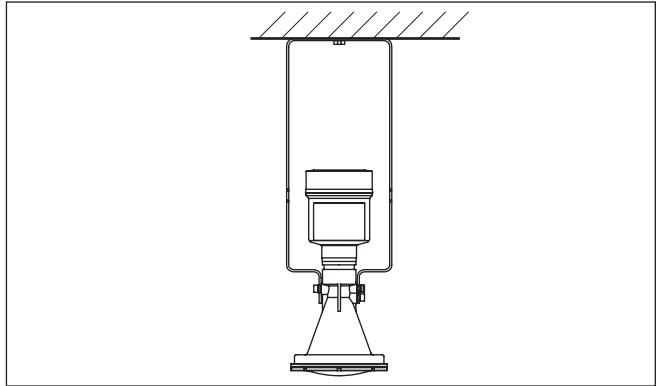

Fig. 2: Ceiling mounting via the mounting strap with length 300 mm

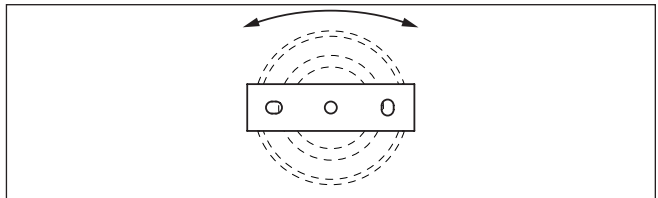

Fig. 3: Rotating with ceil mounting

Mounting strap - Wall mounting

As an alternative the strap mounting is carried out horizontally or obliquely.

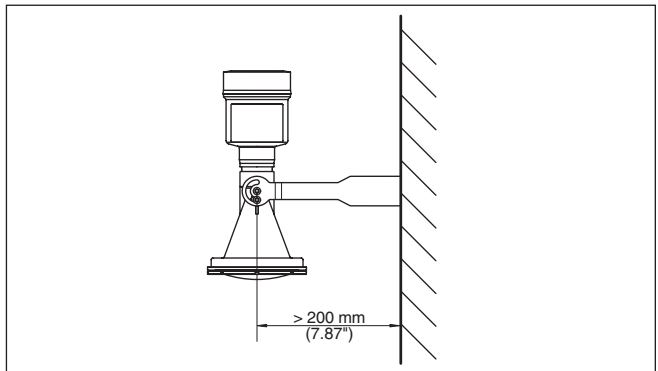

Fig. 4: Wall mounting horizontally via the mounting strap with length 170 mm

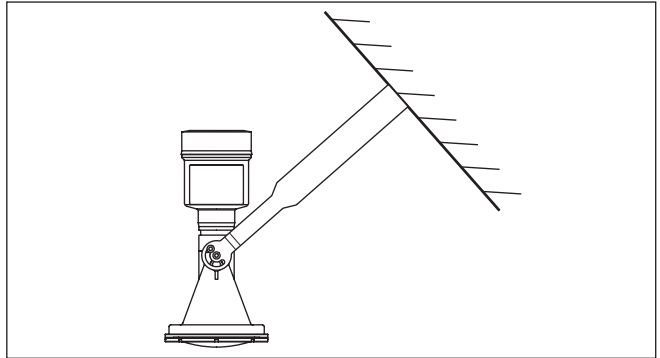

Fig. 5: Wall mounting with inclined wall via the mounting strap with length 300 mm

Flange

Two versions are available for mounting the instrument on a socket:

- Combi compression flange fitting to DN 80 (ASME 3" and JIS 80)
- Adapter flange from DN 100 (ASME 4" or JIS 100)

In the case of instruments with single chamber housing, the compression flange can be passed directly over the housing. With double chamber housings, a later mounting this way is not possible, the mounting method must be specified when ordering.

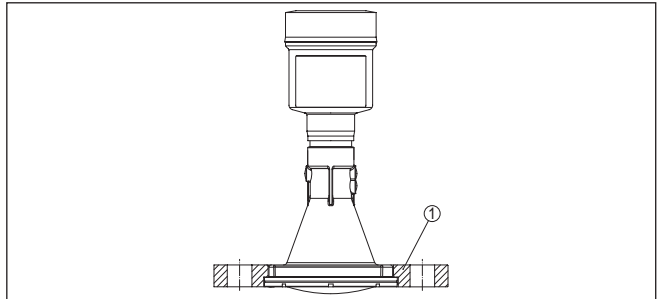

Fig. 6: Combi compression flange

1 Combi compression flange

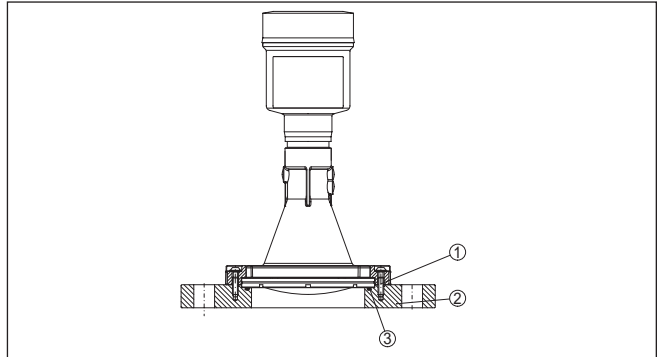

Fig. 7: Adapter flange

- 1 Connection screw
- 2 Adapter flange
- 3 Process seal

You can find drawings of these mounting options in chapter "Dimensions".

4.3 Mounting preparations, mounting strap

The strap is supplied unassembled and must be screwed to the sensor before setup with three hexagon screws M5 x 10 and spring washers. Max. torque, see chapter "Technical data". Required tools: Allen wrench size 4.

There are two ways to screw the strap onto the sensor. Depending on the selected version, the sensors can be swivelled in the strap as follows:

- Single chamber housing
 - Angle of inclination 180°, infinitely variable
 - Angle of inclination in three steps 0°, 90° and 180°
- Double chamber housing
 - Angle of inclination 90°, infinitely variable
 - Angle of inclination in two steps 0° and 90°

4.4 Mounting instructions

Polarisation

Radar sensors for level measurement emit electromagnetic waves. The polarization is the direction of the electrical component of these waves.

The polarization direction is marked by a nose on the housing, see following drawing:

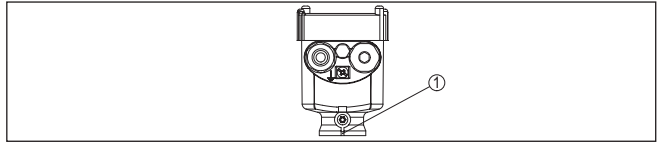

Fig. 8: Position of the polarisation

1 Nose for marking the direction of polarisation



Information:

When the housing is rotated, the direction of polarization changes and hence the influence of the false echo on the measured value. Please keep this in mind when mounting or making changes later.

Installation position

Mount the sensor at least 200 mm (7.874 in) away from the vessel wall.

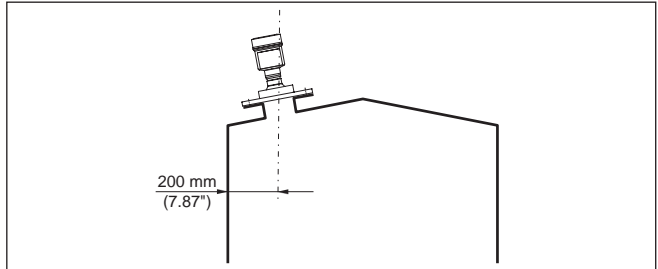

Fig. 9: Mounting the radar sensor on the vessel top

If you cannot maintain this distance, you should carry out a false signal storage during setup. This applies particularly if buildup on the vessel wall is expected. In such cases, we recommend repeating the false signal storage at a later date with existing buildup.

Inflowing medium

The instrument should not be mounted too close to the inflowing medium, as the microwave signal could be disrupted.

Silo with filling from top

The optimal mounting position is opposite the filling aperture. To avoid heavy soiling, the distance to any filter or dust exhauster should be as large as possible.

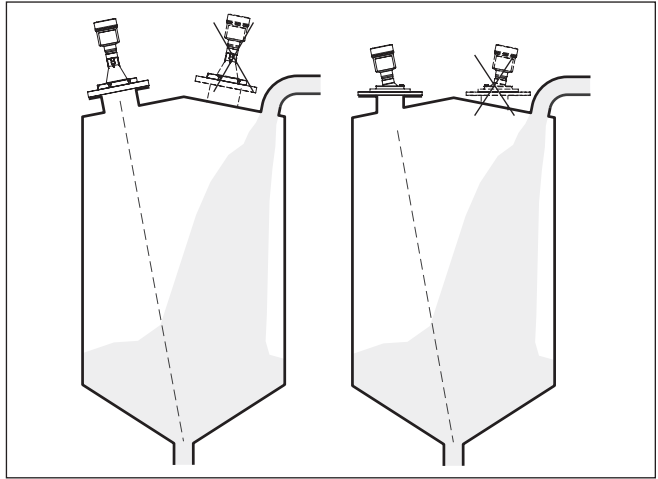

Fig. 10: Mounting of the radar sensor with inflowing medium

Silo with lateral filling

In bulk solids silos with lateral pneumatic filling the instrument should not be mounted above the filling stream, as the microwave signal will be disrupted. The optimal mounting position is next to the filling aperture. To avoid heavy soiling, the distance to any filter or dust exhauster should be as large as possible.

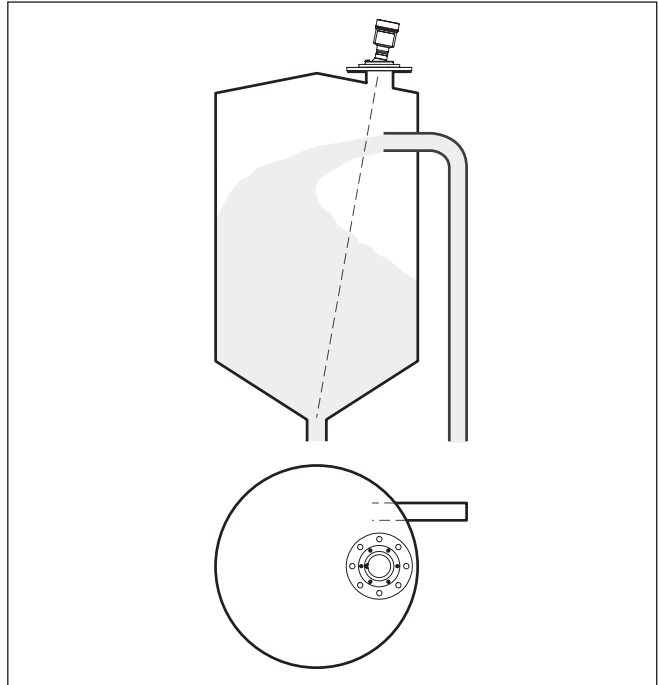

Fig. 11: Mounting of the radar sensor with inflowing medium

Type of socket



Information:

The mounting socket should be as short as possible and its end rounded. This reduces false echoes from the vessel mounting socket.

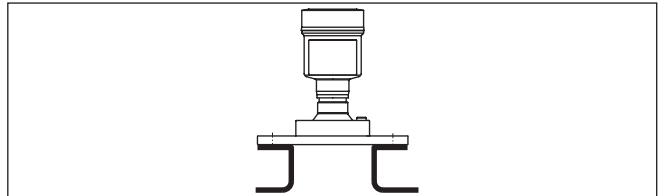

Fig. 12: Recommended socket mounting

If the medium has good reflective properties, you can also mount the VEGAPULS 69 on longer sockets. Approximate socket heights are shown in the following illustration.



Information:

When mounting on longer sockets, we recommend carrying out a false echo storage (see chapter "Parameter adjustment").

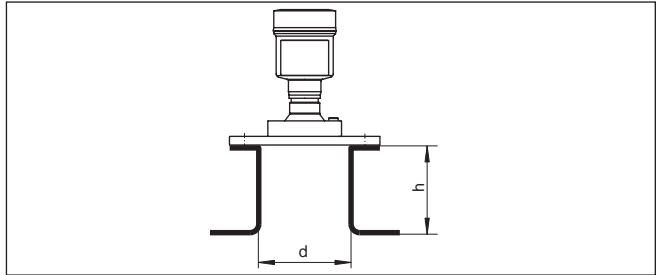

The below charts specify the max. socket piece h depending on the diameter d.

Socket diameter d	Socket length h
80 mm	≤ 200 mm
100 mm	≤ 300 mm
150 mm	≤ 500 mm

Socket diameter d	Socket length h
3"	≤ 7.87 in
4"	≤ 11.8 in
6"	≤ 19.7 in

Orientation

In order to measure as much of the vessel volume as possible, the sensor should be aligned so that the measuring beam reaches the lowest level in the vessel. In a cylindrical silo with conical outlet, the sensor is mounted anywhere from one third to one half of the vessel radius from outside wall (see following drawing).

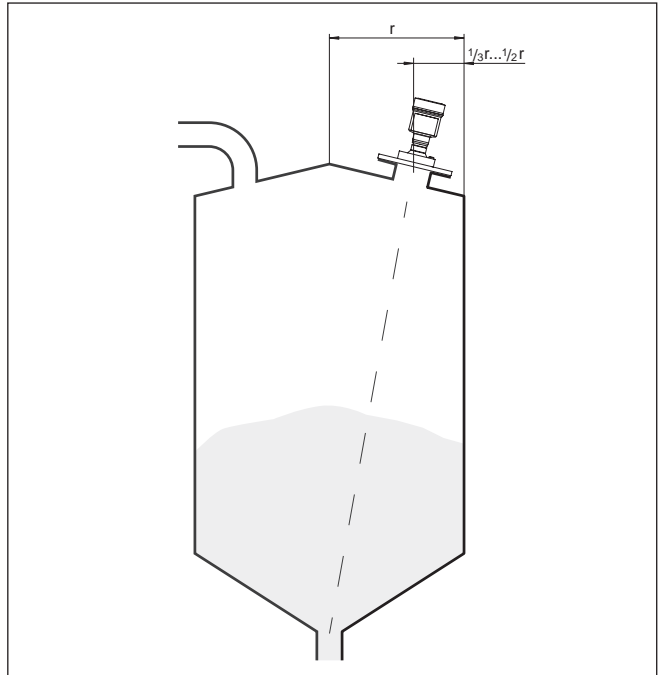

Fig. 14: Mounting position and orientation

With the help of an optional swivelling holder, the sensor can be easily aligned to the vessel centre. The necessary angle of inclination depends on the vessel dimensions. It can be easily checked with a suitable bubble tube or mechanic's level on the sensor.

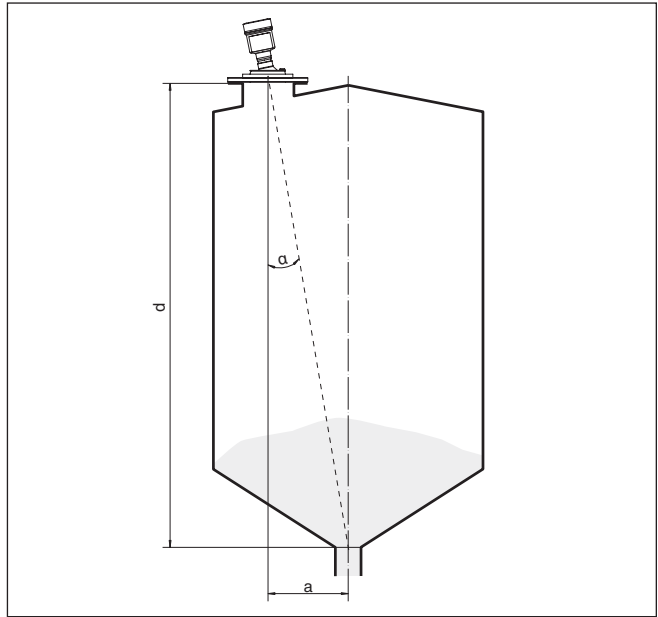

Fig. 15: Proposal for installation after orientation VEGAPULS 69

The following table shows the necessary angle of inclination. It depends on the measuring distance and the distance "a" between vessel centre and installation position.

Distance d (m)	2°	4°	6°	8°	10°
2	0.1	0.1	0.2	0.3	0.4
4	0.1	0.3	0.4	0.6	0.7
6	0.2	0.4	0.6	0.8	1.1
8	0.3	0.6	0.8	1.1	1.4
10	0.3	0.7	1.1	1.4	1.8
15	0.5	1.0	1.6	2.1	2.6
20	0.7	1.4	2.1	2.8	3.5
25	0.9	1.7	2.6	3.5	4.4
30	1	2.1	3.2	4.2	5.3
35	1.2	2.4	3.7	4.9	6.2
40	1.4	2.8	4.2	5.6	7.1
45	1.6	3.1	4.7	6.3	7.9
50	1.7	3.5	5.3	7	8.8
60	2.1	4.2	6.3	8.4	10.5
70	2.4	4.9	7.3	9.7	12.2

Distance d (m)	2°	4°	6°	8°	10°
80	2.8	5.6	8.4	11.1	13.9
90	3.1	6.3	9.4	12.5	15.6
100	3.5	7	10.5	13.9	17.4
110	3.8	7.7	11.5	15.3	19.1
120	4.2	8.4	12.5	16.7	20.8

Example:

In a vessel 20 m high, the installation position of the sensor is 1.4 m from the vessel centre.

The necessary angle of inclination of 4° can be read out from this chart.

Proceed as follows to adjust the angle of inclination with the swivelling holder:

1. Loosen the six clamping screws on the swivelling holder with a size 5 Allen wrench.
2. Align the sensor, check angle of inclination



Information:

The max. angle of inclination of the swivelling holder is approx. 10°

3. Tighten the clamping screws, torque max. 8 Nm.

Vessel installations

The mounting location of the radar sensor should be a place where no other equipment or fixtures cross the path of the microwave signals.

Vessel installations, such as e.g. ladders, limit switches, heating spirals, struts, etc., can cause false echoes and impair the useful echo. Make sure when planning your measuring site that the radar sensor has a "clear view" to the measured product.

In case of existing vessel installations, a false echo storage should be carried out during setup.

If large vessel installations such as struts or supports cause false echoes, these can be attenuated through supplementary measures. Small, inclined sheet metal baffles above the installations scatter the radar signals and prevent direct interfering reflections.

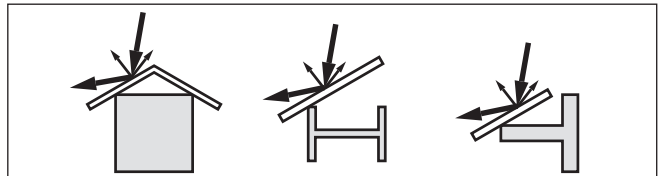

Fig. 16: Cover flat, large-area profiles with deflectors

Material heaps

Large material heaps are best measured with several instruments, which can be mounted on e.g. traverse cranes. For this type of application it is advantageous to orient the sensor perpendicular to the bulk solid surface.

The sensors do not influence each other.



Information:

Keep in mind that for these applications, the sensors are designed for relatively slow level changes. If the sensor is used on a movable boom, the max. measuring rate must be observed (see chapter "Technical data").

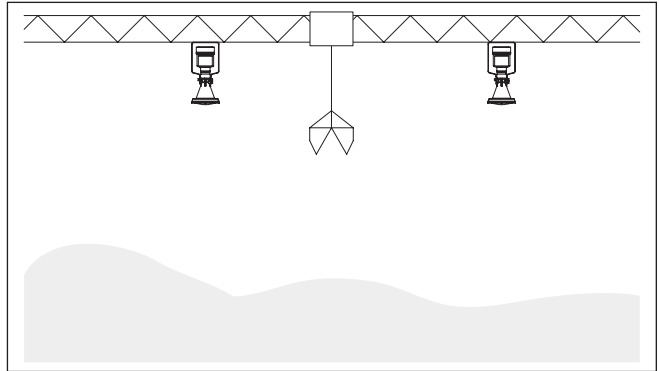

Fig. 17: Radar sensors on traverse crane

Mounting in the vessel insulation

Instruments for a temperature range up to 200° C have a spacer between process fitting and electronics housing. This spacer is used to thermally decouple the electronics from the high process temperatures.



Information:

The spacer may only be incorporated up to a maximum of 50 mm into the vessel insulation. Only then is a reliable temperature decoupling guaranteed.

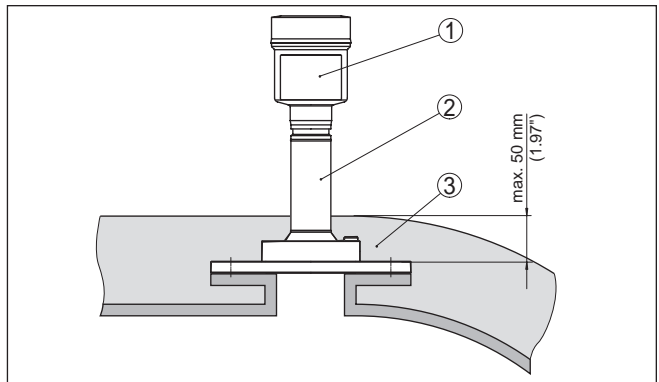

Fig. 18: Mounting the instrument on insulated vessels.

- 1 Electronics housing
- 2 Spacer
- 3 Vessel insulation

Mounting in multiple chamber silo

The walls of multiple-chamber silos are often made of profile material, e.g. profile sheeting, to ensure the required stability. If the radar sensor is mounted very close to a heavily structured vessel wall, substantial interfering reflections can be generated. Thus the sensor should be mounted at the largest possible distance from the separating wall.

The best mounting location is on the outer wall of the silo, with the sensor pointing towards the discharge opening in the silo centre. This can be accomplished, for example, with the mounting strap.

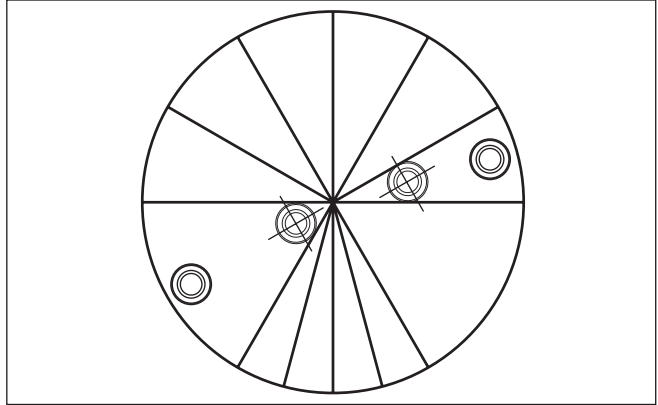

Fig. 19: Installation and orientation in multiple chamber silos

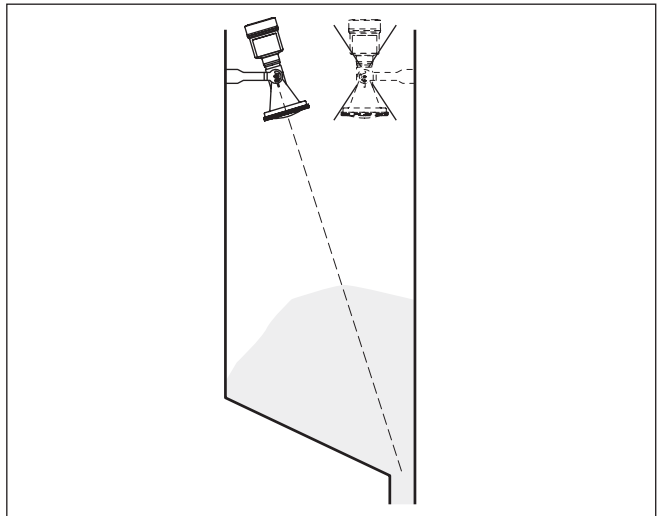

Fig. 20: Installation and orientation in multiple chamber silos

Dust deposits

To avoid heavy buildup and dust on the antenna, the sensor should not be mounted close to the dust exhauster inside the vessel.

To avoid buildup, especially with strong condensation, air rinsing is recommended.

Metal jacketed lens antenna

The VEGAPULS 69 with metal jacketed lens antenna is equipped with a rinsing air connection as a standard feature.

Plastic horn antenna

The VEGAPULS 69 with plastic horn antenna is optionally available with rinsing air connection. The mechanical configuration differs according to the flange version.

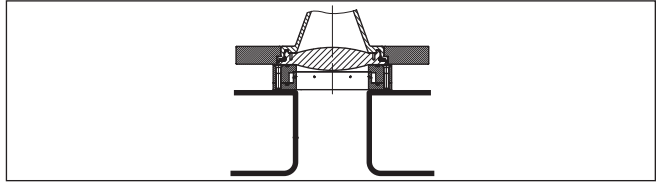

Fig. 21: Rinsing air connection with compression flange

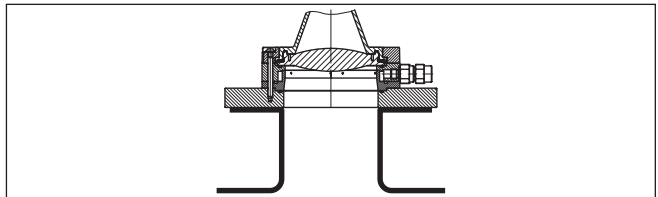

Fig. 22: Rinsing air connection with adapter flange

5 Connecting to power supply

5.1 Preparing the connection

Safety instructions

Always keep in mind the following safety instructions:



Warning:

Connect only in the complete absence of line voltage.

- The electrical connection must only be carried out by trained personnel authorised by the plant operator.
- Generally connect the instrument that connecting and disconnecting is possible in idle state.
- If overvoltage surges are expected, overvoltage arresters should be installed.

Voltage supply via mains voltage

In this case, the instrument is designed in protection class I. To maintain this protection class, it is absolutely necessary that the ground conductor be connected to the internal ground terminal. Take note of the national installation regulations.

Supply voltage and current signal are carried on separate connection cables if reliable separation is required. The supply voltage range can differ depending on the instrument version.

The data for power supply are specified in chapter "*Technical data*".

Voltage supply via low voltage

In this case, the instrument is designed in protection class II. Generally connect the instrument to vessel ground (potential equalization) or with plastic vessels to the next ground potential. For this purpose, a ground terminal is located laterally on the instrument housing.

Connection cable

An approved, three-wire installation cable with PE conductor is required for voltage supply with mains voltage.

The 4 ... 20 mA current output is connected with standard two-wire cable without screen. If electromagnetic interference is expected which is above the test values of EN 61326-1 for industrial areas, screened cable should be used.

Use cable with round cross section for instruments with housing and cable gland. To ensure the seal effect of the cable gland (IP protection rating), find out which cable outer diameter the cable gland is suitable for.

Use a cable gland fitting the cable diameter.

Cable gland ½ NPT

With plastic housing, the NPT cable gland or the Conduit steel tube must be screwed without grease into the threaded insert.

Max. torque for all housings see chapter "*Technical data*".

Cable screening and grounding

If screened cable is required, we recommend connecting the cable screen on both ends to ground potential. In the sensor, the screen must be connected directly to the internal ground terminal. The ground terminal on the outside of the housing must be connected to the ground potential (low impedance).

In Ex systems, the grounding is carried out according to the installation regulations.

5.2 Connection

Connection technology

The voltage supply and signal output are connected via the spring-loaded terminals in the housing.

Connection to the display and adjustment module or to the interface adapter is carried out via contact pins in the housing.



Information:

The terminal block is pluggable and can be removed from the electronics. To do this, lift the terminal block with a small screwdriver and pull it out. When reinserting the terminal block, you should hear it snap in.

Connection procedure

Proceed as follows:

1. Unscrew the housing cover
2. Loosen compression nuts of the cable glands
3. Remove approx. 10 cm (4 in) of the cable mantle (signal output), strip approx. 1 cm (0.4 in) insulation from the ends of the individual wires
4. Insert the cable into the sensor through the cable entry



Fig. 23: Connection steps 5 and 6

5. Insert the wire ends into the terminals according to the wiring plan



Information:

Solid cores as well as flexible cores with wire end sleeves are inserted directly into the terminal openings. In case of flexible cores without end sleeves, press the terminal from above with a small screwdriver, the terminal opening is then free. When the screwdriver is released, the terminal closes again.

6. Check the hold of the wires in the terminals by lightly pulling on them
7. Connect the screen to the internal ground terminal, connect the outer ground terminal to potential equalisation in case of power supply via low voltage
8. Connect the lead cable for power supply in the same way according to the wiring plan, in addition connect the ground conductor to the inner ground terminal when powered with mains voltage.
9. Tighten the compression nut of the cable glands. The seal ring must completely encircle the cables
10. Screw the housing cover back on

The electrical connection is finished.



Information:

The terminal blocks are pluggable and can be removed from the housing insert. To do this, lift the terminal block with a small screwdriver and pull it out. When inserting the terminal block again, you should hear it snap in.

5.3 Wiring plan, double chamber housing



The following illustrations apply to the non-Ex as well as to the Ex-d version.

Electronics compartment

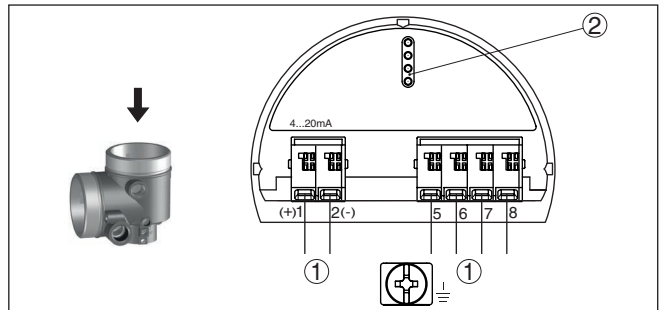

Fig. 24: Electronics compartment, double chamber housing

- 1 Internal connection to the terminal compartment
- 2 For display and adjustment module or interface adapter
- 3 Internal connection to the plug connector for external display and adjustment unit (optional)



Information:

The connection of an external display and adjustment unit is not possible with this double chamber housing.

Connection compartment with mains voltage

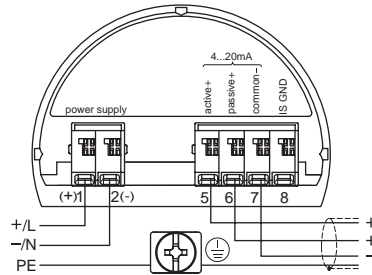

Fig. 25: Connection compartment with double chamber housing with mains voltage

Terminal	Function	Polarity
1	Voltage supply	+/L
2	Voltage supply	-/N
5	4 ... 20 mA output (active)	+
6	4 ... 20 mA output (passive)	+
7	Mass - output	-
8	Function ground with installation according to CSA	

Connection compartment with low voltage

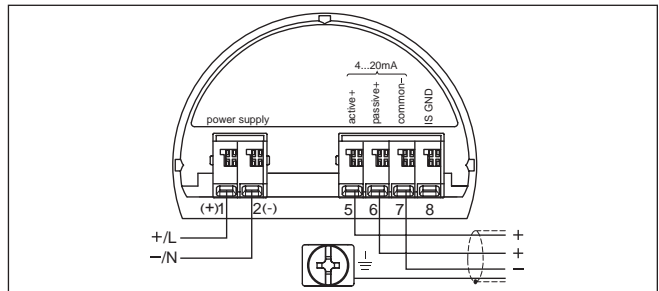

Fig. 26: Connection compartment with double chamber housing with low voltage

Terminal	Function	Polarity
1	Voltage supply	+/L
2	Voltage supply	-/N
5	4 ... 20 mA output (active)	+
6	4 ... 20 mA output (passive)	+
7	Mass - output	-
8	Function ground with installation according to CSA	

5.4 Double chamber housing with DIS-ADAPT

Electronics compartment

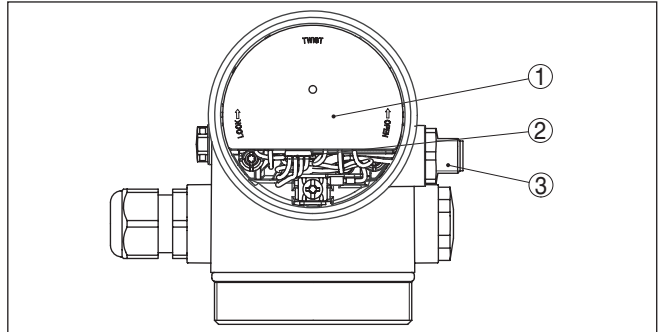

Fig. 27: View to the electronics compartment with DISADAPT for connection of the external display and adjustment unit

- 1 DIS-ADAPT
- 2 Internal plug connection
- 3 Plug connector M12 x 1

Assignment of the plug connector

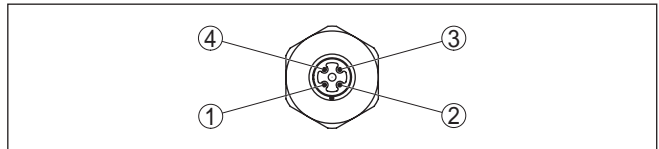

Fig. 28: View to the plug connector M12 x 1

- 1 Pin 1
- 2 Pin 2
- 3 Pin 3
- 4 Pin 4

Contact pin	Colour connection cable in the sensor	Terminal, electronics module
Pin 1	Brown	5
Pin 2	White	6
Pin 3	Blue	7
Pin 4	Black	8

5.5 Switch-on phase

After connecting the instrument to power supply or after a voltage recurrence, the instrument carries out a self-check for approx. 30 s:

- Internal check of the electronics
- Indication of the instrument type, hardware and software version, measurement loop name on the display or PC
- Indication of the status message "F 105 Determine measured value" on the display or PC
- The output signal jumps to the set fault current

As soon as a plausible measured value is found, the corresponding current is outputted to the signal cable. The value corresponds to the actual level as well as the settings already carried out, e.g. factory setting.

6 Set up with the display and adjustment module

6.1 Insert display and adjustment module

The display and adjustment module can be inserted into the sensor and removed again at any time. You can choose any one of four different positions - each displaced by 90°. It is not necessary to interrupt the power supply.

Proceed as follows:

1. Unscrew the housing cover
2. Place the display and adjustment module on the electronics in the desired position and turn it to the right until it snaps in.
3. Screw housing cover with inspection window tightly back on

Disassembly is carried out in reverse order.

The display and adjustment module is powered by the sensor, an additional connection is not necessary.



Fig. 29: Insertion of the display and adjustment module with single chamber housing



Note:

If you intend to retrofit the instrument with a display and adjustment module for continuous measured value indication, a higher cover with an inspection glass is required.

6.2 Adjustment system

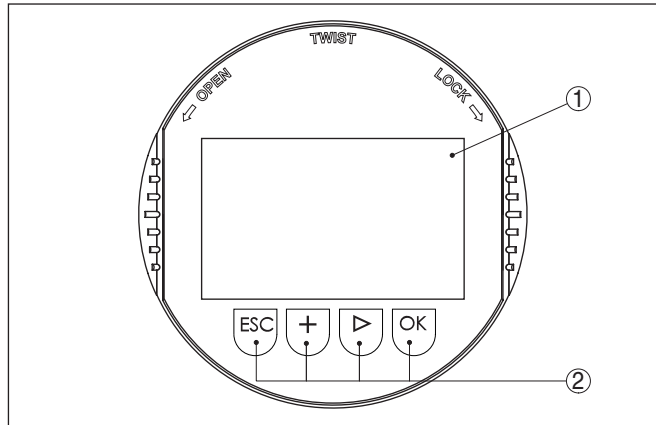

Fig. 30: Display and adjustment elements

- 1 LC display
- 2 Adjustment keys

Key functions

- **[OK]** key:
 - Move to the menu overview
 - Confirm selected menu
 - Edit parameter
 - Save value
- **[->]** key:
 - Presentation, change measured value
 - Select list entry
 - Select editing position
- **[+]** key:
 - Change value of the parameter
- **[ESC]** key:
 - Interrupt input
 - Jump to next higher menu

Adjustment system

The instrument is adjusted via the four keys of the display and adjustment module. The LC display indicates the individual menu items. The functions of the individual keys are shown in the above illustration. Approx. 60 minutes after the last pressing of a key, an automatic reset to measured value indication is triggered. Any values not confirmed with **[OK]** will not be saved.

6.3 Measured value indication - Selection national language

Measured value indication

With the **[->]** key you move between three different indication modes. In the first view, the selected measured value is displayed in large digits.

In the second view, the selected measured value and a corresponding bar graph presentation are displayed.

In the third view, the selected measured value as well as a second selectable value, e.g. the temperature of the electronics, are displayed.

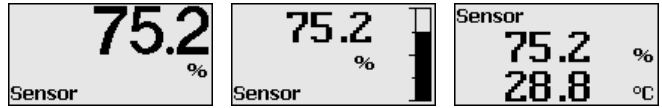

During the initial setup of an instrument shipped Ex works, use the "OK" key to get to the menu "National language".

Selection of national language

This menu item is used to select the national language for further parameter adjustment. You can change the selection via the menu item "Setup - Display, Menu language".

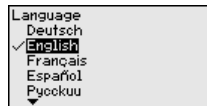

With the "OK" key you move to the main menu.

6.4 Parameter adjustment - Quick setup

To quickly and easily adapt the sensor to the application, select the menu item "Quick setup" in the start graphic on the display and adjustment module.



Carry out the following steps in the below sequence.

You can find "Extended adjustment" in the next sub-chapter.

1. Measurement loop name

In the first menu item you assign a suitable measurement loop name. Permitted are names with max. 19 characters.

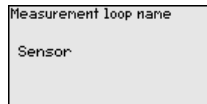

2. Medium

In this menu item you select the type of bulk solid. The selection comprises different granulate sizes.

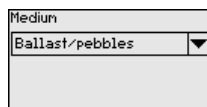

3. Application/Vessel bottom

In this menu item you specify the application and the form of the vessel bottom.

Application	Silo
Vessel bottom	Conical

4. Vessel height/Measuring range

In this menu item you enter the height of the vessel and hence the active measuring range.

Vessel height/Meas. range	120.00 m
---------------------------	----------

5. Max. adjustment

In this menu item you carry out the max. adjustment.

Enter the measuring distance for 100 % filling.

Max. adjustment	100.00 %	
	≙	
	0.00 m	
	4.96 m	

6. Min. adjustment

In this menu item you carry out the min. adjustment.

Enter the measuring distance for 0 % filling.

Min. adjustment	0.00 %	
	≙	
	120.00 m	
	4.96 m	

The quick setup is finished.

6.5 Parameter adjustment - Extended adjustment

The main menu is divided into five sections with the following functions:

Setup
Display
Diagnostics
Additional adjustments
Info

Setup: Settings, e.g., for measurement loop name, units, application, adjustment, signal output

Display: Settings, e.g., for language, measured value display, lighting

Diagnosis: Information, for example, of device status, peak value, simulation, echo curve

Additional adjustments: Date/Time, reset, copy function, scaling, current output, false signal suppression, linearization, HART mode, special parameters

Main menu

Info: Instrument name, hardware and software version, calibration date, instrument features

In the main menu point "Setup", the individual submenu points should be selected one after the other and provided with the correct parameters to ensure optimum adjustment of the measurement. The procedure is described in the following.

Setup - Measurement loop name

Here you can assign a suitable measurement loop name. Push the "OK" key to start the processing. With the "+" key you change the sign and with the "->" key you jump to the next position.

You can enter names with max. 19 characters. The character set comprises:

- Capital letters from A ... Z
- Numbers from 0 ... 9
- Special characters + - / _ blanks

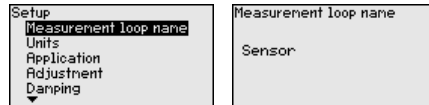

Setup - Units

In this menu item you select the distance unit and the temperature unit.

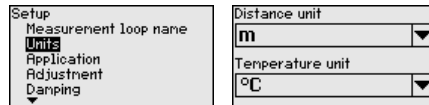

For the distance units you can choose between m, in and ft and for the temperature units °C, °F and K.

Setup - Application

With this menu item, the sensor can be optimally adapted to the application, the installation location or the measurement conditions. It includes selection options for medium, application as well as vessel height/measuring range.

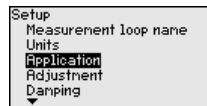

Medium:

Every medium has a different reflective behaviour. With this selection, the sensor can be perfectly adapted to the medium and measurement reliability, particularly with media with poor reflective properties, is considerably increased.

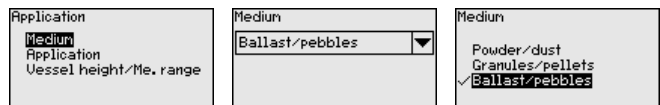

Application:

Depending on the type of bulk solids application, material cones and additional echoes from the vessel wall or bottom can become further interfering factors. Through this selection, the sensor is adapted perfectly to the application.

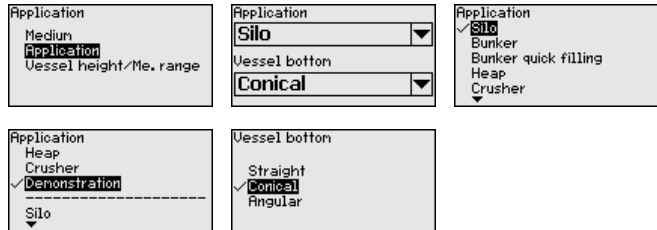
**Vessel height/Measuring range:**

The VEGAPULS 69 is a radar sensor for bulk solids in high, slender vessels. For this reason, it covers a measuring range of up to 120 m. This menu item allows a limitation of the active measuring range in which the sensor searches for level echoes.

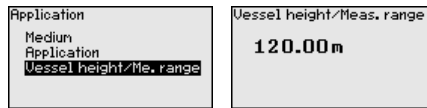
**Information:**

The min. adjustment must be carried out independently of this. The following features form the basis of the applications:

Silo (slender and high):

- Vessel of metal: weld joints
- Process/measurement conditions:
 - Filling aperture too close to the sensor
 - System noise in completely empty silo increased
- Properties, sensor:
 - Stable measured values through higher averaging
 - False signal suppression during setup recommended, required for automatic false signal suppression
 - Automatic false signal suppression with partly filled vessel¹⁾

Bunker (large-volume):

- Vessel of concrete or metal:
 - Structured vessel walls
 - Installations present
- Process/measurement conditions:
 - Large distance to the medium
 - Large angles of repose
- Properties, sensor:

¹⁾ The instrument recognizes if a manual false signal suppression was carried out with empty vessel and high system noise. An automatic false signal suppression is then carried out if a product echo was detected at the beginning of the filling process.

- Mean averaging
- High measured value jumps are accepted

Bunker with fast filling:

- Vessel of concrete or metal, also multiple chamber silo:
 - Structured vessel walls
 - Installations present
- Process/measurement conditions:
 - Measured value jumps, e.g. through truck loading
 - Large distance to the medium
 - Large angles of repose
- Properties, sensor:
 - Lower averaging
 - Very high measured value jumps are accepted

Heap:

- Sensor mounting on movable conveyor belts
- Detection of the heap profile
- Height detection during filling
- Process/measurement conditions:
 - Measured value jumps, e.g. by the profile of the heap or traverses
 - Large angles of repose
 - Measurement near the filling stream
- Properties, sensor:
 - Mean averaging
 - High measured value jumps are accepted

Crusher:

- Vessel: installations, wear and protective facilities available
- Process/measurement conditions:
 - Measured value jumps, e.g. through truck loading
 - Fast reaction time
 - Large distance to the medium
- Properties, sensor:
 - Little averaging
 - Max. reaction speed, very high measured value jumps are accepted

Demonstration:

- Adjustment for all applications which are not typically level measurement
 - Instrument demonstration
 - Object recognition/monitoring (additional settings required)
- Properties, sensor:
 - Sensor accepts all measured value changes within the measuring range immediately
 - High sensitivity against interferences, because virtually no averaging

Enter the requested parameters via the appropriate keys, save your settings with **[OK]** and jump to the next menu item with the **[ESC]** and the **[->]** key.

Setup - Adjustment

Since the radar sensor is a distance measuring instrument, the distance from the sensor to the product surface is measured. For indication of the real level, an allocation of the measured distance to the percentage height must be carried out.

To perform the adjustment, enter the distance with full and empty vessel, see the following example:

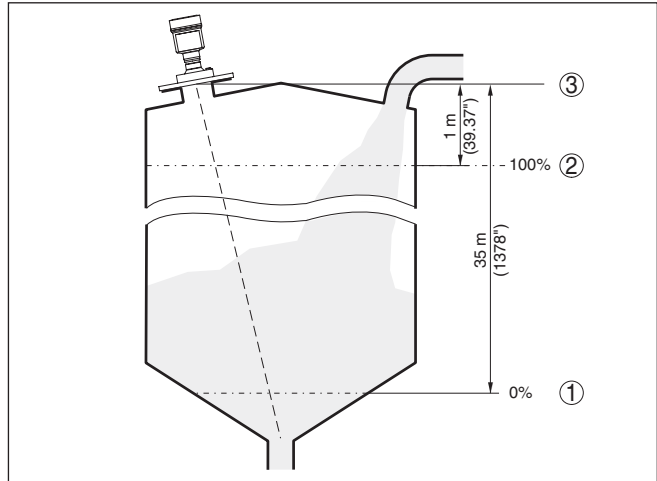

Fig. 31: Parameter adjustment example min./max. adjustment

- 1 Min. level = max. meas. distance
- 2 Max. level = min. meas. distance
- 3 Reference plane

If these values are not known, an adjustment with the distances of for example 10 % and 90 % is possible. Starting point for these distance specifications is always the seal surface of the thread or flange. You can find specifications of the reference plane in chapter "Technical data". By means of these settings, the real level will be calculated.

The real product level during this adjustment is not important, because the min./max. adjustment is always carried out without changing the product level. These settings can be made ahead of time without the instrument having to be installed.

Setup - Max. adjustment

Proceed as follows:

1. Select with [**->**] the menu item "Max. adjustment" and confirm with [**OK**].

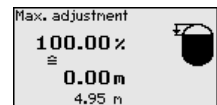
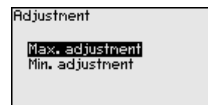
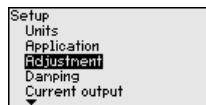

2. Prepare the percentage value for editing with [**OK**] and set the cursor to the requested position with [**->**].

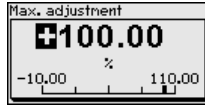

- Set the requested percentage value with **[+]** and save with **[OK]**.
The cursor jumps now to the distance value.

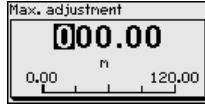

- For the full vessel, enter the distance value in m matching the percentage value.
- Save settings with **[OK]** and move with **[ESC]** and **[->]** to the min. adjustment.

Setup - Min. adjustment

Proceed as follows:

- Select with **[->]** the menu item "Min. adjustment" and confirm with **[OK]**.

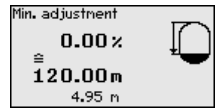
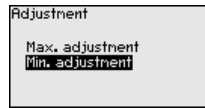
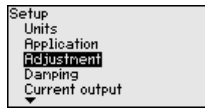

- Edit the percentage value with **[OK]** and set the cursor to the requested position with **[->]**.

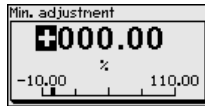

- Set the requested percentage value with **[+]** and save with **[OK]**.
The cursor jumps now to the distance value.

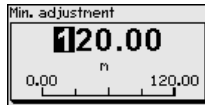

- Enter the suitable distance value in m for the empty vessel (e.g. distance from the sensor to the vessel bottom) corresponding to the percentage value.

Setup - Damping

To damp process-dependent measured value fluctuations, set an integration time of 0 ... 999 s in this menu item.

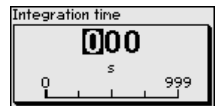
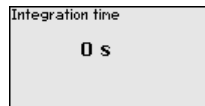
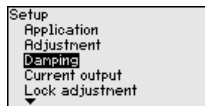

The default setting is a damping of 0 s.

Setup - Current output mode

In the menu item "Current output mode" you determine the output characteristics and reaction of the current output in case of failure.

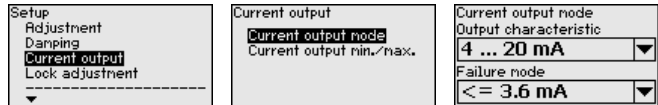

The default setting is output characteristics 4 ... 20 mA, failure mode < 3.6 mA.

Setup - Current output Min./Max.

In the menu item "Current output Min./Max.", you determine the reaction of the current output during operation.

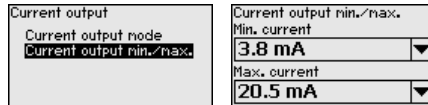

The default setting is min. current 3.8 mA and max. current 20.5 mA.

Lock/unlock setup - Adjustment

In the menu item "Lock/unlock adjustment", you can protect the sensor parameters against unauthorized or inadvertent modification. The PIN is activated/deactivated permanently.

With active PIN, only the following adjustment functions are possible without entering a PIN:

- Select menu items and show data
- Read data from the sensor into the display and adjustment module.



Caution:

With active PIN, adjustment via PACTware/DTM as well as other systems is also blocked.

Display - Language

This menu item enables the setting of the requested national language.

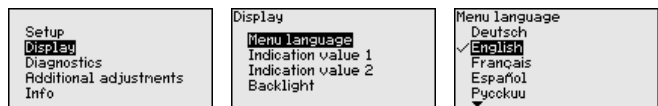

The following languages are available:

- German
- English
- French
- Spanish
- Russian
- Italian
- Dutch
- Portuguese
- Polish
- Czech

- Turkish

In the delivery status, the VEGAPULS 69 is set to the ordered national language.

Display - Displayed value 1 and 2

In this menu item you can define the way measured values are indicated on the display.

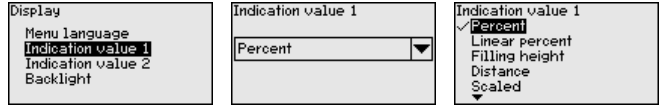

The default setting for the display value is "Percent".

Display - Backlight

The display and adjustment module has a backlight for the display. In this menu item you can switch on the lighting. You can find the required operating voltage in chapter "Technical data".

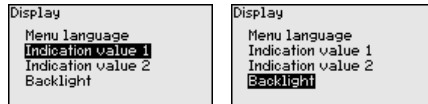

The lighting is switched off in delivery status.

Diagnostics - Device status

In this menu item, the device status is displayed.

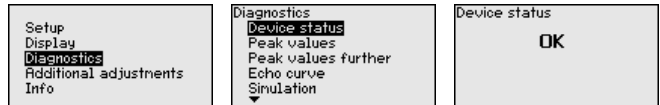

Diagnosis - Peak value

The min. and max. measured value, the measurement reliability as well as the min. and max. electronics temperature are stored in the sensor. The values are displayed in the menu item "Peak value".

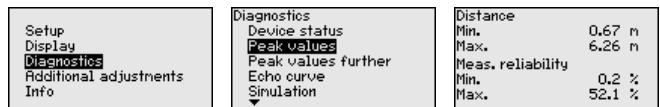

A reset menu is opened with the [OK] key in the respective peak value window:

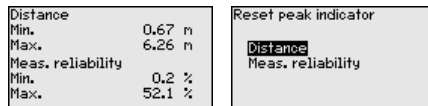

With the [OK] key, the peak values are reset to the actual measured value.

Diagnostics - Echo curve

The "Echo curve" shows the signal strength of the echoes over the measuring range in dB. The signal strength enables an evaluation of the quality of the measurement.

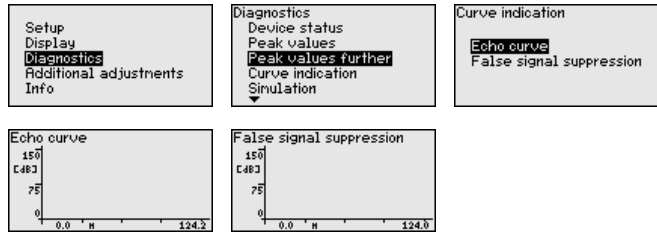

The selected curve is continuously updated. A submenu with zoom functions is opened with the **[OK]** key:

- "X-Zoom": Zoom function for the meas. distance
- "Y-Zoom": 1, 2, 5 and 10x signal magnification in "dB"
- "Unzoom": Reset the presentation to the nominal measuring range without magnification

Diagnosis - Simulation

In this menu item you can simulate measured values via the current output. This allows the signal path to be tested, e.g. through downstream indicating instruments or the input card of the control system.

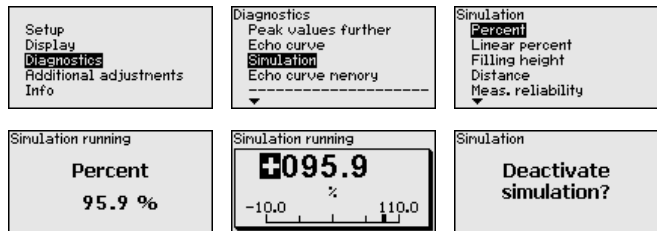

Select the requested simulation variable and set the requested value.



Caution:

During simulation, the simulated value is outputted as 4 ... 20 mA current value and as digital HART signal. The status message within the context of the asset management function is "Maintenance".

Push the **[ESC]** key to deactivate the simulation.



Information:

The simulation is terminated automatically 60 minutes after the last key has been pressed.

Diagnosics - Echo curve memory

The function "Setup" allows the echo curve to be saved at the time of setup.



Information:

This is generally recommended, however, for use of the Asset Management functions it is absolutely necessary. Saving should be carried out with a very low level.

The function "Echo curve memory" allows up to ten individual echo curves to be stored, for example to detect the measurement behaviour of the sensor in different operating conditions.

With the adjustment software PACTware and the PC, the stored echo curves can be displayed with high resolution and used to recognize signal changes over time. In addition, the echo curve saved during setup can also be displayed in the echo curve window and compared with the actual echo curve.

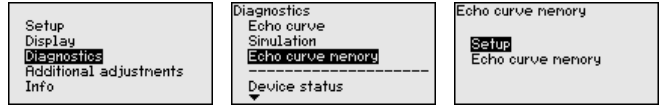

Additional adjustments - Date Time

In this menu item, the internal clock of the sensor is set to the requested time and time format. At the time of shipment from factory, the instrument is set to CET (Central European Time).

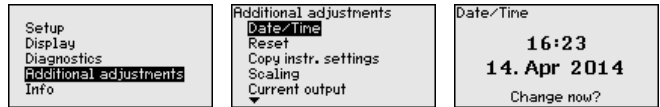

Additional adjustments - Reset

During a reset, the parameter settings carried out by the user are reset to the default values (see below table).

Proceed as follows:

1. Select with **[->]** under "Additional adjustment" the menu item "Reset" and confirm with **[OK]**.

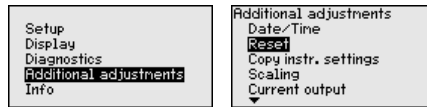

2. Confirm with **[OK]** and select the requested reset function with **[->]**



3. Confirm with **[OK]**, for approx. 5 s the message "Resetting" is displayed, then the selection window appears.



Caution:

For the duration of the reset, the set trouble signal is outputted via the current output. Within the context of the asset management function, the message "Maintenance" is outputted.

The following reset functions are available:

Delivery status: Restores the parameter settings at the time of shipment from the factory, incl. the order-specific settings. Any created false signal suppression, user-programmable linearization curve as

well as measured value and echo curve memory is deleted. The event and parameter modification memories remain unaffected.

Basic settings: Resets the parameter settings, incl. special parameters, to the default values of the respective instrument. Any stored false signal suppression or user programmable linearisation curve, as well as the measured value memory, is deleted. Order-related settings are not taken over into the current parameters after this reset.

The following table shows the scope of the reset function and the default values of the instrument:

Menu	Menu item	Default value
Setup	Measurement loop name	Sensor
	Units	Distance in m Temperature in °C
	Application	Medium: Crushed stones/gravel Application: Silo Vessel bottom: Flat Vessel height/Measuring range: 120 m
	Min. adjustment	120 m
	Max. adjustment	0,000 m(d)
	Damping	0.0 s
	Current output mode	Output characteristics: 4 ... 20 mA Failure mode: < 3.6 mA ▼
	Current output Min./Max.	Min. current: 3.8 mA ▼ Max. current: 20.5 mA
Display	Displayed value 1	Filling height
	Displayed value 2	Temperature
	Backlight	Switched off
Additional adjustments	Date/Time	Time format: 24 h
	Scaling size	Volume l
	Scaling format	100.00 lin %, 100 l 0.00 lin %, 0 l
	Current output 1 and 2 size	Lin %
	Current output 1 and 2 adjustment	100.00 %, 100 l 0.00 %, 0 l
	Linearization	Linear
	HART mode	HART address: 0 Loop current mode: Analogue current output

Additional adjustments - Copy instrument settings

The instrument settings are copied with this function. The following functions are available:

Read from sensor: Read data from sensor and store into the display and adjustment module

Write into sensor: Store data from the display and adjustment module back to the sensor

The following data or settings for adjustment of the display and adjustment module are saved:

- All data of the menu "Setup" and "Display"
- The menu items "Reset, Date/Time" in the menu "Additional settings"
- The user-programmable linearization curve

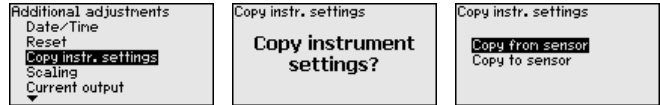

The copied data are permanently saved in an EEPROM memory in the display and adjustment module and remain there even in case of power failure. From there, they can be written into one or more sensors or kept as backup for a possible electronics exchange.



Note:

Before saving the data in the sensor, a safety check is made if the data match with the sensor. For this purpose the sensor type of the source data as well as the target sensor are displayed. If the data do not match, a failure message is outputted or the function is blocked. The data are only saved after release.

Additional settings - Scaling

In the menu item "Scaling" you define the scaling variable and the scaling format for the indication of the level measured value for 0 % and 100 % on the display, for example as volume in l.

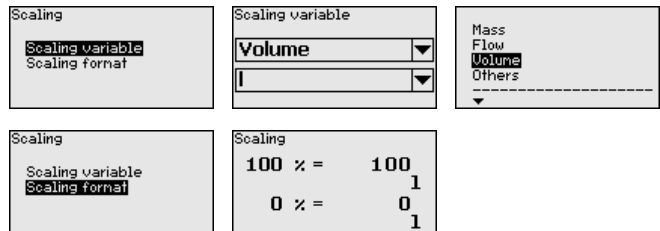

Additional settings - Current output 1 and 2 (size)

In menu item "Current output, variable" you specify which measured variable the current output refers to.

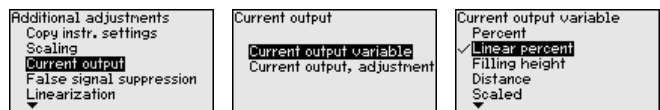

Additional settings - Current output 1 and 2 (adjustment)

In menu item "Current output, adjustment" you can assign a respective measured value to the current output.

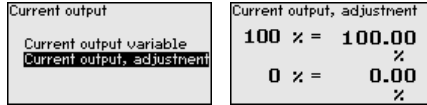

Additional adjustments - False signal suppression

The following circumstances cause interfering reflections and can influence the measurement:

- High sockets
- Vessel installations such as struts
- Agitators
- Buildup or welded joints on vessel walls



Note:

A false signal suppression detects, marks and saves these false signals so that they are no longer taken into account in the level measurement.

This should be done with a low level so that all potential interfering reflections can be detected.

Proceed as follows:

1. Select with [**->**] the menu item "False signal suppression" and confirm with [**OK**].

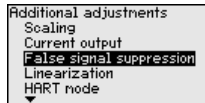

2. Confirm again with [**OK**].



3. Confirm again with [**OK**].

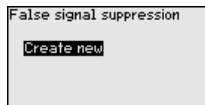

4. Confirm again with [**OK**] and enter the actual distance from the sensor to the product surface.

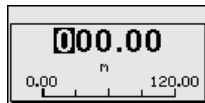

5. All interfering signals in this section are detected by the sensor and stored after confirming with [**OK**].



Note:

Check the distance to the product surface, because if an incorrect (too large) value is entered, the existing level will be saved as false signal. The filling level would then no longer be detectable in this area.

If a false signal suppression has already been created in the sensor, the following menu window appears when selecting "*False signal suppression*":

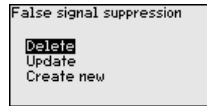

Delete: An already created false signal suppression will be completely deleted. This is useful if the saved false signal suppression no longer matches the metrological conditions in the vessel.

Extend: is used to extend an already created false signal suppression. This is useful if a false signal suppression was carried out with a too high level and not all false signals could be detected. When selecting "*Extend*", the distance to the product surface of the created false signal suppression is displayed. This value can now be changed and the false signal suppression can be extended to this range.

Setup - Linearization

A linearization is necessary for all vessels in which the vessel volume does not increase linearly with the level. Corresponding linearization curves are preprogrammed for these vessels. They represent the correlation between the level percentage and vessel volume. The linearization applies to the measured value indication and the current output.

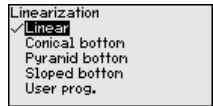
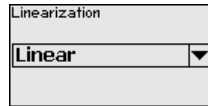
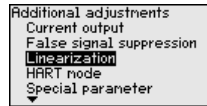

Additional adjustments - HART mode

In this menu item you determine the HART mode and enter the address for multidrop mode.

In the mode "*Fixed current output*" up to 63 sensors can be operated on one two-wire cable (Multidrop operation). An address between 0 and 63 must be assigned to each sensor.

When choosing the function "*Analogue current output*", then a 4 ... 20 mA signal is outputted in multidrop mode.

With the mode "*Fixed current (4 mA)*" a fixed 4 mA signal is outputted independently of the actual level.

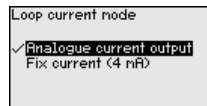
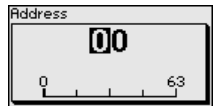
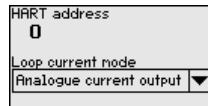
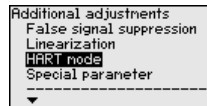

The default setting is "*Analogue current output*" and the address "00".

Additional adjustments - Special parameters

In this menu item you gain access to the protected area where you can enter special parameters. In exceptional cases, individual

parameters can be modified in order to adapt the sensor to special requirements.

Change the settings of the special parameters only after having contacted our service staff.

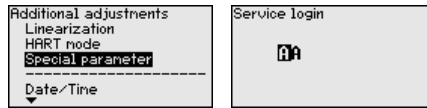

Info - Instrument name

In this menu item, you can read out the instrument name and the instrument serial number:

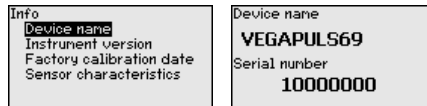

Info - Instrument version

In this menu item, the hardware and software version of the sensor is displayed.

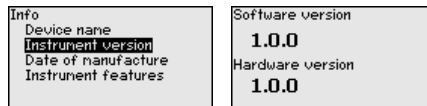

Info - Factory calibration date

In this menu item, the date of factory calibration of the sensor as well as the date of the last change of sensor parameters are displayed via the display and adjustment module or via the PC.

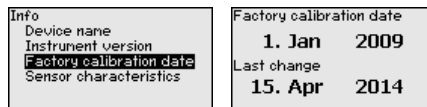

Info - Sensor characteristics

In this menu item, the features of the sensor such as approval, process fitting, seal, measuring range, electronics, housing and others are displayed.

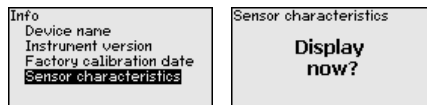

6.6 Saving the parameter adjustment data

We recommend noting the adjusted data, e.g. in this operating instructions manual, and archiving them afterwards. They are thus available for multiple use or service purposes.

If the instrument is equipped with a display and adjustment module, the data in the sensor can be saved in the display and adjustment module. The procedure is described in the operating instructions manual "Display and adjustment module" in the menu item "Copy sensor data". The data remain there permanently even if the sensor power supply fails.

The following data or settings for adjustment of the display and adjustment module are saved:

- All data of the menu "Setup" and "Display"
- In the menu "Additional adjustments" the items "Sensor-specific units, temperature unit and linearization"
- The values of the user programmable linearization curve

The function can also be used to transfer settings from one instrument to another instrument of the same type. If it is necessary to exchange a sensor, the display and adjustment module is inserted into the replacement instrument and the data are likewise written into the sensor via the menu item "Copy sensor data".

7 Setup with PACTware

7.1 Connect the PC

Via the interface adapter directly on the sensor

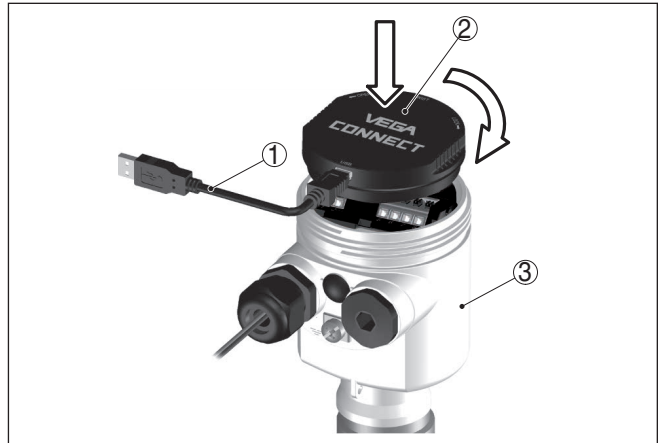

Fig. 32: Connection of the PC directly to the sensor via the interface adapter

- 1 USB cable to the PC
- 2 Interface adapter VEGACONNECT
- 3 Sensor

Connection via HART

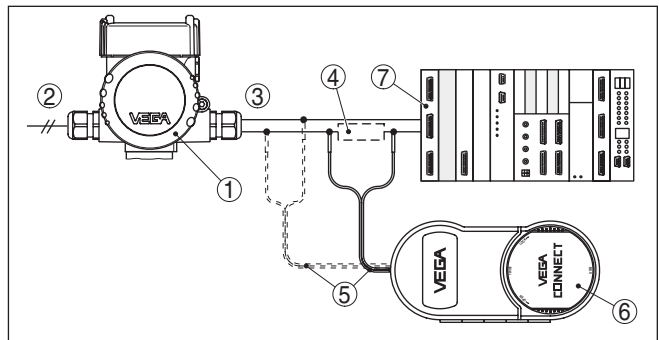

Fig. 33: Connecting the PC via HART to the signal cable

- 1 VEGAPULS 69
- 2 Voltage supply
- 3 4 ... 20 mA signal output
- 4 HART resistance approx. 250 Ω (optional depending on processing)
- 5 Connection cable with 2 mm pins and terminals
- 6 VEGACONNECT
- 7 Processing system/PLC

Necessary components:

- VEGAPULS 69
- PC with PACTware and suitable VEGA DTM

- VEGACONNECT
- HART resistance approx. 250 Ω
- Processing system/PLC



Note:

With power supply units with integrated HART resistance (internal resistance approx. 250 Ω), an additional external resistance is not necessary. This applies, e.g. to the VEGA instruments VEGATRENN 149A, VEGAMET 381 and VEGAMET 391). Commercially available Ex separators are also usually equipped with sufficient current limitation resistance. In such cases, VEGACONNECT can be connected parallel to the 4 ... 20 mA cable.

7.2 Parameter adjustment

Prerequisites

For parameter adjustment of the instrument via a Windows PC, the configuration software PACTware and a suitable instrument driver (DTM) according to FDT standard are required. The latest PACTware version as well as all available DTMs are compiled in a DTM Collection. The DTMs can also be integrated into other frame applications according to FDT standard.



Note:

To ensure that all instrument functions are supported, you should always use the latest DTM Collection. Furthermore, not all described functions are included in older firmware versions. You can download the latest instrument software from our homepage. A description of the update procedure is also available in the Internet.

Further setup steps are described in the operating instructions manual "DTM Collection/PACTware" attached to each DTM Collection and which can also be downloaded from the Internet. Detailed descriptions are available in the online help of PACTware and the DTMs.

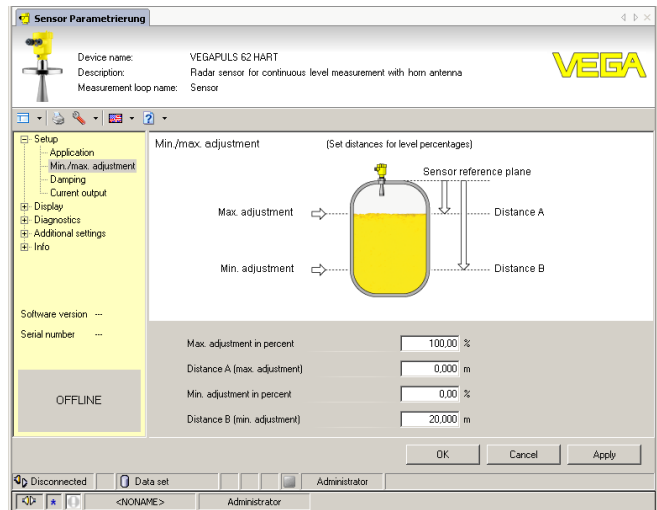

Fig. 34: Example of a DTM view

Standard/Full version

All device DTMs are available as a free-of-charge standard version and as a full version that must be purchased. In the standard version, all functions for complete setup are already included. An assistant for simple project configuration simplifies the adjustment considerably. Saving/printing the project as well as import/export functions are also part of the standard version.

In the full version there is also an extended print function for complete project documentation as well as a save function for measured value and echo curves. In addition, there is a tank calculation program as well as a multiviewer for display and analysis of the saved measured value and echo curves.

The standard version is available as a download under www.vega.com/downloads and "*Software*". The full version is available on CD from the agency serving you.

7.3 Saving the parameter adjustment data

We recommend documenting or saving the parameter adjustment data via PACTware. That way the data are available for multiple use or service purposes.

8 Set up with other systems

8.1 DD adjustment programs

Device descriptions as Enhanced Device Description (EDD) are available for DD adjustment programs such as, for example, AMS™ and PDM.

The files can be downloaded at www.vega.com/downloads under "Software".

8.2 Field Communicator 375, 475

Device descriptions for the instrument are available as EDD for parameter adjustment with the Field Communicator 375 or 475.

For the integration of the EDD in the Field Communicator 375 or 475, the software "Easy Upgrade Utility" is required which is available from the manufacturer. This software is updated via the Internet and new EDDs are automatically taken over into the device catalogue of this software after they are released by the manufacturer. They can then be transferred to a Field Communicator.

9 Diagnosis, asset management and service

9.1 Maintenance

If the device is used correctly, no maintenance is required in normal operation.

In some applications, buildup on the antenna system can influence the measuring result. Depending on the sensor and application, make arrangements to avoid strong pollution of the antenna system. If necessary, clean the antenna system in certain intervals.

9.2 Measured value and event memory

The instrument has several memories which are available for diagnosis purposes. The data remain even with voltage interruption.

Measured value memory

Up to 100,000 measured values can be stored in the sensor in a ring memory. Each entry contains date/time as well as the respective measured value. Storable values are for example:

- Distance
- Filling height
- Percentage value
- Lin. percent
- Scaled
- Current value
- Meas. reliability
- Electronics temperature

When the instrument is shipped, the measured value memory is active and stores distance, measurement reliability and electronics temperature every 3 minutes.

The requested values and recording conditions are set via a PC with PACTware/DTM or the control system with EDD. Data are thus read out and also reset.

Event memory

Up to 500 events are automatically stored with a time stamp in the sensor (non-deletable). Each entry contains date/time, event type, event description and value. Event types are for example:

- Modification of a parameter
- Switch-on and switch-off times
- Status messages (according to NE 107)
- Error messages (according to NE 107)

The data are read out via a PC with PACTware/DTM or the control system with EDD.

Echo curve memory

The echo curves are stored with date and time and the corresponding echo data. The memory is divided into two sections:

Echo curve of the setup: This is used as reference echo curve for the measurement conditions during setup. Changes in the measurement conditions during operation or buildup on the sensor can thus be recognized. The echo curve of the setup is stored via:

- PC with PACTware/DTM
- Control system with EDD
- Display and adjustment module

Further echo curves: Up to 10 echo curves can be stored in a ring buffer in this memory section. Further echo curves are stored via:

- PC with PACTware/DTM
- Control system with EDD

9.3 Asset Management function

The instrument features self-monitoring and diagnostics according to NE 107 and VDI/VDE 2650. In addition to the status messages in the following tables there are more detailed error messages available under the menu item "Diagnostics" via the display and adjustment module, PACTware/DTM and EDD.

Status messages

The status messages are divided into the following categories:

- Failure
- Function check
- Out of specification
- Maintenance requirement

and explained by pictographs:

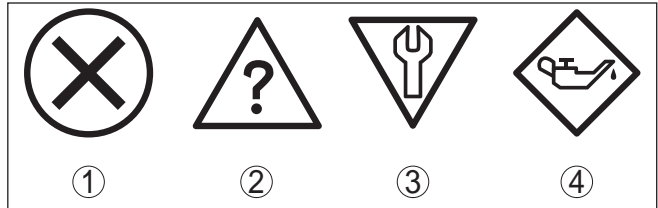

Fig. 35: Pictographs of the status messages

- 1 Failure - red
- 2 Out of specification - yellow
- 3 Function check - orange
- 4 Maintenance - blue

Failure: Due to a malfunction in the instrument, a failure message is outputted.

This status message is always active. It cannot be deactivated by the user.

Function check: The instrument is in operation, the measured value is temporarily invalid (for example during simulation).

This status message is inactive by default. It can be activated by the user via PACTware/DTM or EDD.

Out of specification: The measured value is unstable because the instrument specification is exceeded (e.g. electronics temperature).

This status message is inactive by default. It can be activated by the user via PACTware/DTM or EDD.

Maintenance: Due to external influences, the instrument function is limited. The measurement is affected, but the measured value is still valid. Plan in maintenance for the instrument because a failure is expected in the near future (e.g. due to buildup).

This status message is inactive by default. It can be activated by the user via PACTware/DTM or EDD.

Failure

The following table shows the error codes in the status message "Failure" and gives information on the reason and rectification. Keep in mind that some information is only valid with four-wire instruments.

Code Text message	Cause	Rectification
F013 no measured value available	<ul style="list-style-type: none"> - Sensor does not detect an echo during operation - Antenna system dirty or defective 	<ul style="list-style-type: none"> - Check or correct installation and/or parameter adjustment - Clean or exchange process component or antenna
F017 Adjustment span too small	<ul style="list-style-type: none"> - Adjustment not within specification 	<ul style="list-style-type: none"> - Change adjustment according to the limit values (difference between min. and max. ≥ 10 mm)
F025 Error in the linearization table	<ul style="list-style-type: none"> - Index markers are not continuously rising, for example illogical value pairs 	<ul style="list-style-type: none"> - Check linearization table - Delete table/Create new
F036 No operable software	<ul style="list-style-type: none"> - Failed or interrupted software update 	<ul style="list-style-type: none"> - Repeat software update - Check electronics version - Exchanging the electronics - Send instrument for repair
F040 Error in the electronics	<ul style="list-style-type: none"> - Hardware defect 	<ul style="list-style-type: none"> - Exchanging the electronics - Send instrument for repair
F080 General software error	<ul style="list-style-type: none"> - General software error 	<ul style="list-style-type: none"> - Disconnect operating voltage briefly
F105 Determine measured value	<ul style="list-style-type: none"> - The instrument is still in the start phase, the measured value could not yet be determined 	<ul style="list-style-type: none"> - Wait for the end of the switch-on phase - Duration depending on the version and parameter adjustment up to approximately 3 min.
F113 Communication error	<ul style="list-style-type: none"> - EMC interference - Transmission error with the external communication with 4-wire power supply unit 	<ul style="list-style-type: none"> - Remove EMC influences - Exchange 4-wire power supply unit or electronics

Code Text message	Cause	Rectification
F125 Impermissible electronics temperature	<ul style="list-style-type: none"> - Temperature of the electronics in the non-specified range 	<ul style="list-style-type: none"> - Check ambient temperature - Isolate electronics - Use instrument with higher temperature range
F260 Error in the calibration	<ul style="list-style-type: none"> - Error in the calibration carried out in the factory - Error in the EEPROM 	<ul style="list-style-type: none"> - Exchanging the electronics - Send instrument for repair
F261 Error in the instrument settings	<ul style="list-style-type: none"> - Error during setup - False signal suppression faulty - Error when carrying out a reset 	<ul style="list-style-type: none"> - Repeat setup - Carry out a reset
F264 Installation/ Setup error	<ul style="list-style-type: none"> - Adjustment not within the vessel height/measuring range - Max. measuring range of the instrument not sufficient 	<ul style="list-style-type: none"> - Check or correct installation and/or parameter adjustment - Use an instrument with bigger measuring range
F265 Measurement function disturbed	<ul style="list-style-type: none"> - Sensor no longer carries out a measurement - Operating voltage too low 	<ul style="list-style-type: none"> - Check operating voltage - Carry out a reset - Disconnect operating voltage briefly

Function check

The following table shows the error codes and text messages in the status message "*Function check*" and provides information on causes as well as corrective measures.

Code Text message	Cause	Rectification
C700 Simulation active	<ul style="list-style-type: none"> - A simulation is active 	<ul style="list-style-type: none"> - Finish simulation - Wait for the automatic end after 60 mins.

Out of specification

The following table shows the error codes and text messages in the status message "*Out of specification*" and provides information on causes as well as corrective measures.

Code Text message	Cause	Rectification
S600 Impermissible electronics temperature	<ul style="list-style-type: none"> - Temperature of the electronics in the non-specified range 	<ul style="list-style-type: none"> - Check ambient temperature - Isolate electronics - Use instrument with higher temperature range

Code Text message	Cause	Rectification
S603 Impermissible operating voltage	– Operating voltage below specified range	– Check electrical connection – if necessary, increase operating voltage

Maintenance

The following table shows the error codes and text messages in the status message "Maintenance" and provides information on causes as well as corrective measures.

Code Text message	Cause	Rectification
M500 Error with the reset delivery status	– With the reset to delivery status, the data could not be restored	– Repeat reset – Load XML file with sensor data into the sensor
M501 Error in the non-active linearization table	– Hardware error EEPROM	– Exchanging the electronics – Send instrument for repair
M502 Error in the event memory	– Hardware error EEPROM	– Exchanging the electronics – Send instrument for repair
M503 Meas. reliability too low	– The echo/noise ratio is too small for reliable measurement – Antenna dirty or defective	– Check installation and process conditions – Change polarisation direction – Use instrument with higher sensitivity – Clean the antenna
M504 Error on an device interface	– Hardware defect	– Check connections – Exchanging the electronics – Send instrument for repair
M505 No echo available	– Sensor does not detect an echo during operation – Antenna dirty or defective	– Clean the antenna – Use a more suitable antenna/sensor – Remove possible false echoes – Optimize sensor position and orientation
M506 Installation/ Setup error	– Error during setup	– Check or correct installation and/or parameter adjustment

Code Text message	Cause	Rectification
M507 Error in the instrument settings	<ul style="list-style-type: none"> - Error during setup - Error when carrying out a reset - False signal suppression faulty 	<ul style="list-style-type: none"> - Carry out reset and repeat setup

9.4 Rectify faults

Reaction when malfunctions occur

The operator of the system is responsible for taking suitable measures to rectify faults.

Procedure for fault rectification

The first measures are:

- Evaluation of fault messages, for example via the display and adjustment module
- Checking the output signal
- Treatment of measurement errors

Further comprehensive diagnostics options are available with a PC with PACTware and the suitable DTM. In many cases, the reasons can be determined in this way and faults rectified.

Check the 4 ... 20 mA signal

Connect a multimeter in the suitable measuring range according to the wiring plan. The following table describes possible errors in the current signal and helps to remove them:

Error	Cause	Rectification
4 ... 20 mA signal not stable	<ul style="list-style-type: none"> - Fluctuations of the measured variable 	<ul style="list-style-type: none"> - Set damping according to the instrument via the display and adjustment module or PACTware/DTM
4 ... 20 mA signal missing	<ul style="list-style-type: none"> - Electrical connection faulty 	<ul style="list-style-type: none"> - Check connection according to chapter "<i>Connection steps</i>" and if necessary, correct according to chapter "<i>Wiring plan</i>"
	<ul style="list-style-type: none"> - Voltage supply missing 	<ul style="list-style-type: none"> - Check cables for breaks; repair if necessary
	<ul style="list-style-type: none"> - Operating voltage too low or load resistance too high 	<ul style="list-style-type: none"> - Check, adapt if necessary
Current signal greater than 22 mA or less than 3.6 mA	<ul style="list-style-type: none"> - Electronics module in the sensor defective 	<ul style="list-style-type: none"> - Exchange the instrument or send it in for repair

Treatment of measurement errors with bulk solids

The below tables show typical examples for application-relevant measurement errors with bulk solids. A distinction is made between measurement errors during:

- Constant level

- Filling
- Emptying

The images in column "Error pattern" show the real level with a broken line and the level displayed by the sensor as a continuous line.

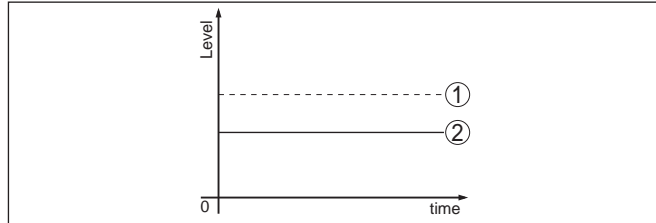

- 1 Real level
- 2 Level displayed by the sensor

Notes:

- Wherever the sensor displays a constant value, the reason could also be the fault setting of the current output to "Hold value"
- If the level indication is too low, the reason could be a line resistance that is too high

Measurement error with constant level

Fault description	Error pattern	Cause	Rectification
1. Measured value shows a too low or too high level		- Min./max. adjustment not correct	- Adapt min./max. adjustment
		- Incorrect linearization curve	- Adapt linearization curve
2. Measured value jumps towards 100 %		- Due to the process, the amplitude of the product echo decreases	- Carry out a false signal suppression
		- A false signal suppression was not carried out	
		- Amplitude or position of a false signal has changed (e.g. condensation, buildup); false signal suppression no longer matches actual conditions	- Determine the reason for the changed false signals, carry out false signal suppression, e.g. with condensation

Measurement error during filling

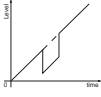
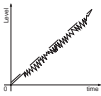
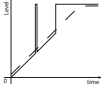
Fault description	Error pattern	Cause	Rectification
3. Measured value jumps towards 0 % during filling		- Amplitude of a multiple echo (vessel top - product surface) is larger than the level echo	- Check parameter "Application", especially vessel top, type of medium, dished bottom, high dielectric constant, and adapt if necessary
		- The level echo cannot be distinguished from the false signal at a false signal position (jumps to multiple echo)	- Remove/reduce false signal: minimize interfering installations by changing the polarization direction - Chose a more suitable installation position
		- Transverse reflection from an extraction funnel, amplitude of the transverse reflection larger than the level echo	- Direct sensor to the opposite funnel wall, avoid crossing with the filling stream
4. Measured value fluctuates around 10 ... 20 %		- Various echoes from an uneven product surface, e.g. a material cone	- Check parameter "Type of medium" and adapt, if necessary - Optimize installation position and sensor orientation
		- Reflections from the product surface via the vessel wall (deflection)	- Select a more suitable installation position, optimize sensor orientation, e.g. with a swiveling holder
5. Measured value jumps sporadically to 100 % during filling		- Changing condensation or contamination on the antenna	- Carry out a false signal suppression or increase false signal suppression with condensation/contamination in the close range by editing - With bulk solids use radar sensor with purging air connection or flexible antenna cover

Measurement error during emptying

Fault description	Error pattern	Cause	Rectification
6. Measured value remains unchanged in the close range during emptying		- False signal larger than the level echo - Level echo too small	- Remove false signals in the close range. Check: Antenna must protrude out of the socket - Remove contamination on the antenna - Minimize interfering installations in the close range by changing the polarization direction - After removing the false signals, the false signal suppression must be deleted. Carry out a new false signal suppression

47249-EN-140707

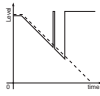
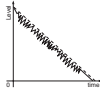
Fault description	Error pattern	Cause	Rectification
7. Measured value jumps sporadically towards 100 % during emptying		– Changing condensation or contamination on the antenna	– Carry out false signal suppression or increase false signal suppression in the close range by editing – With bulk solids use radar sensor with purging air connection or flexible antenna cover
8. Measured value fluctuates around 10 ... 20 %		– Various echoes from an uneven product surface, e.g. an extraction funnel – Reflections from the product surface via the vessel wall (deflection)	– Check parameter "Type of medium" and adapt, if necessary – Optimize installation position and sensor orientation

Reaction after fault rectification

Depending on the reason for the fault and the measures taken, the steps described in chapter "*Setup*" must be carried out again or must be checked for plausibility and completeness.

24 hour service hotline

Should these measures not be successful, please call in urgent cases the VEGA service hotline under the phone no. **+49 1805 858550**.

The hotline is also available outside normal working hours, seven days a week around the clock.

Since we offer this service worldwide, the support is provided in English. The service itself is free of charge, the only costs involved are the normal call charges.

9.5 Exchanging the electronics module

If the electronics module is defective, it can be replaced by the user.



In Ex applications, only instruments and electronics modules with appropriate Ex approval may be used.

If there is no electronics module available on site, the electronics module can be ordered through the agency serving you. The electronics modules are adapted to the respective sensor and differ in signal output or voltage supply.

The new electronics module must be loaded with the default settings of the sensor. These are the options:

- In the factory
- Or on site by the user

In both cases, the serial number of the sensor is needed. The serial numbers are stated on the type label of the instrument, on the inside of the housing as well as on the delivery note.

When loading on site, first of all the order data must be downloaded from the Internet (see operating instructions manual "*Electronics module*").



Caution:

All user-specific settings must be entered again. Hence, you have to carry out a new setup after the electronics exchange.

If you have stored the data of the parameter adjustment during the first setup of the sensor, you can transfer these to the replacement electronics module. A new setup is no more necessary.

9.6 Software update

The following components are required to update the instrument software:

- Instrument
- Voltage supply
- Interface adapter VEGACONNECT
- PC with PACTware
- Current instrument software as file

You can find the current instrument software as well as detailed information on the procedure under "www.vega.com/downloads" and "*Software*".



Caution:

Instruments with approvals can be bound to certain software versions. Therefore make sure that the approval is still effective after a software update is carried out.

You can find detailed information at www.vega.com/downloads and "*Approvals*".

9.7 How to proceed if a repair is needed

You can find a repair form as well as detailed information on how to proceed at www.vega.com/downloads and "*Forms and certificates*".

By doing this you help us carry out the repair quickly and without having to call back for needed information.

If a repair is necessary, please proceed as follows:

- Print and fill out one form per instrument
- Clean the instrument and pack it damage-proof
- Attach the completed form and, if need be, also a safety data sheet outside on the packaging
- Please contact the agency serving you to get the address for the return shipment. You can find the agency on our home page www.vega.com.

10 Dismount

10.1 Dismounting steps

**Warning:**

Before dismantling, be aware of dangerous process conditions such as e.g. pressure in the vessel or pipeline, high temperatures, corrosive or toxic products etc.

Take note of chapters "*Mounting*" and "*Connecting to power supply*" and carry out the listed steps in reverse order.

10.2 Disposal

The instrument consists of materials which can be recycled by specialised recycling companies. We use recyclable materials and have designed the parts to be easily separable.

Correct disposal avoids negative effects on humans and the environment and ensures recycling of useful raw materials.

Materials: see chapter "*Technical data*"

If you have no way to dispose of the old instrument properly, please contact us concerning return and disposal.

WEEE directive 2002/96/EG

This instrument is not subject to the WEEE directive 2002/96/EG and the respective national laws. Pass the instrument directly on to a specialised recycling company and do not use the municipal collecting points. These may be used only for privately used products according to the WEEE directive.

11 Supplement

11.1 Technical data

General data

316L corresponds to 1.4404 or 1.4435

Materials, wetted parts

- Process fitting 316L, Alloy C22, Alloy 400
- Process seal On site
- Antenna 316L, PP, PEEK
- seal, antenna system FKM (SHS FPM 70C3 GLT), EPDM (COG AP310)

Materials, non-wetted parts

- Plastic housing plastic PBT (Polyester)
- Aluminium die-casting housing Aluminium die-casting AlSi10Mg, powder-coated - basis: Polyester
- Stainless steel housing 316L
- Seal between housing and housing cover NBR (stainless steel housing, precision casting), silicone (aluminium/plastic housing; stainless steel housing, electropolished)
- Inspection window in housing cover (optional) Polycarbonate
- Ground terminal 316L

Process fitting

- Flanges DIN from DN 80, ASME from 3"

Weights

- Instrument (depending on housing, process fitting and antenna) approx. 2 ... 17.2 kg (4.409 ... 37.92 lbs)

Torque for NPT cable glands and Conduit tubes

- Plastic housing max. 10 Nm (7.376 lbf ft)
- Aluminium/Stainless steel housing max. 50 Nm (36.88 lbf ft)

Input variable

Measured variable The measured variable is the distance between the process fitting of the sensor and the product surface. The reference plane is the seal surface of the flange.

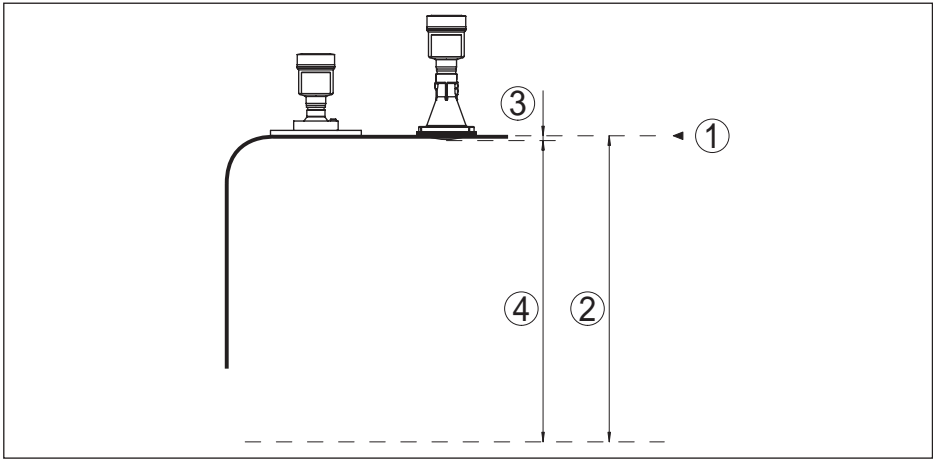

Fig. 45: Data of the input variable

- 1 Reference plane
- 2 Measured variable, max. measuring range
- 3 Antenna length
- 4 Useful measuring range

Max. measuring range 120 m (393,7 ft)

Output variable

Output signals	4 ... 20 mA/HART - active; 4 ... 20 mA/HART - passive
Range of the output signal	3.8 ... 20.5 mA/HART (default setting)
Terminal voltage passive	9 ... 30 V DC
Shortcircuit protection	Available
Potential separation	Available
Signal resolution	0.3 μ A
Failure signal current output (adjustable)	mA-value unchanged 20.5 mA, 22 mA, < 3.6 mA
Max. output current	22 mA
Starting current	\leq 3.6 mA
Load (4 ... 20 mA/HART - active)	< 500 Ω
Damping (63 % of the input variable)	0 ... 999 s, adjustable
HART output values	
– PV (Primary Value)	Distance to the level
– SV (Secondary Value)	Level as percentage value
– TV (Third Value)	Linearised percentage value
– QV (Fourth Value)	Scaled measured value
Resolution, digital	< 1 mm (0.039 in)

Accuracy (according to DIN EN 60770-1)

Process reference conditions according to DIN EN 61298-1

- Temperature +18 ... +30 °C (+64 ... +86 °F)
- Relative humidity 45 ... 75 %
- Air pressure 860 ... 1060 mbar/86 ... 106 kPa (12.5 ... 15.4 psig)

Installation reference conditions

- Min. distance to internal installations > 200 mm (7.874 in)
- Reflector Flat plate reflector
- False reflections Biggest false signal, 20 dB smaller than the useful signal

Deviation See following diagrams

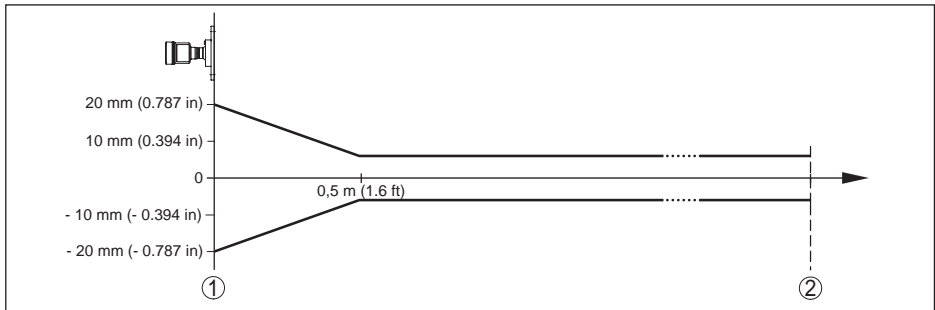

Fig. 46: Deviation under reference conditions

- 1 Reference plane
- 2 Measuring range end

- Repeatability $\leq \pm 1$ mm
- Deviation with bulk solids The values depend to a great extent on the application. Binding specifications are thus not possible.
- Deviation under EMC influence $\leq \pm 50$ mm

Variables influencing measurement accuracy

Specifications apply to the digital measured value

- Temperature drift - Digital output ± 3 mm/10 K, max. 10 mm
- Additional deviation through electromagnetic interference acc. to EN 61326 $< \pm 50$ mm

Specifications apply also to the current output

- Temperature drift - Current output ± 0.03 %/10 K relating to the 16 mA span max. ± 0.3 %
- Deviation on the current output through analogue/digital conversion $< \pm 15$ μ A
- Deviation on the current output due to strong, high frequency electromagnetic fields acc. to EN 61326 $< \pm 150$ μ A

Characteristics and performance data

- Measuring frequency W-band (79 GHz technology)

47249-EN-140707

Measuring cycle time approx.	700 ms
Step response time ²⁾	≤ 3 s
Beam angle ³⁾	
– Plastic horn antenna	3.5°
– Metal jacketed lens antenna	4°
Emitted HF power (depending on the parameter adjustment) ⁴⁾	
– Average spectral transmission power density	-3 dBm/MHz EIRP
– Max. spectral transmission power density	+34 dBm/50 MHz EIRP
– Max. power density at a distance of 1 m	< 3 μW/cm ²

Ambient conditions

Ambient, storage and transport temperature -40 ... +80 °C (-40 ... +176 °F)

Process conditions

For the process conditions, please also note the specifications on the type label. The lowest value always applies.

Process temperature

Seal	Antenna lens	Process temperature (measured on the process fitting)
FKM (SHS FPM 70C3 GLT)	PEEK	-40 ... +130 °C (-40 ... +266 °F)
	PEEK	-40 ... +200 °C (-40 ... +392 °F)
FKM (SHS FPM 70C3 GLT)	PP	-40 ... +80 °C (-40 ... +176 °F)
EPDM (COG AP310)	PP	-40 ... +80 °C (-40 ... +176 °F)

Ambient temperature - Process temperature

²⁾ Time span (after a sudden measuring distance change of max. 2 m in bulk solids applications) until the output signal has taken on 90 % of the final value for the first time (IEC 61298-2).

³⁾ Outside the specified beam angle, the energy of the radar signal is reduced by 50 % (-3 dB)

⁴⁾ EIRP: Equivalent Isotropic Radiated Power

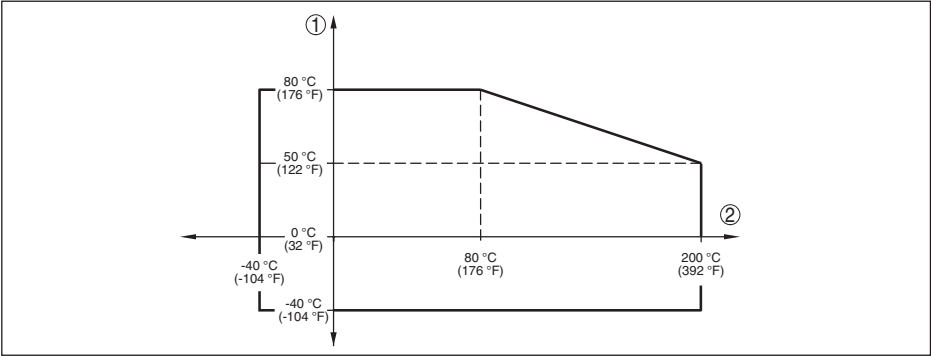

Fig. 47: Ambient temperature - Process temperature, metal jacketed lens antenna up to +200 °C (392 °F)

- 1 Ambient temperature
- 2 Process temperature

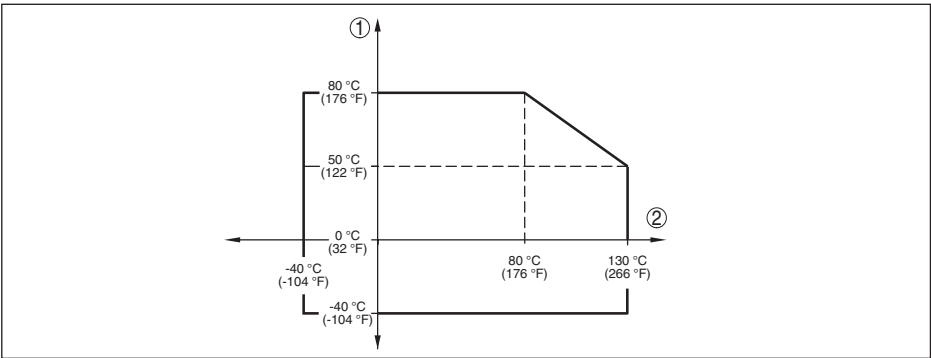

Fig. 48: Ambient temperature - Process temperature, metal jacketed lens antenna up to +130 °C (266 °F)

- 1 Ambient temperature
- 2 Process temperature

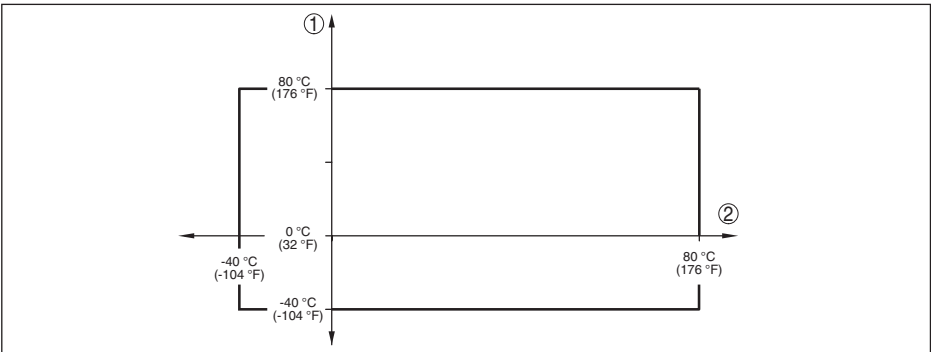

Fig. 49: Ambient temperature - Process temperature, plastic horn antenna

- 1 Ambient temperature
- 2 Process temperature

47249-EN-140707

Vessel pressure

Vessel pressure

- Metal jacketed lens antenna -1 ... 3 bar (-100 ... 300 kPa/-14.5 ... 43.5 psig)
- Plastic horn antenna -1 ... 2 bar (-100 ... 200 kPa/-14.5 ... 29.1 psig)
- Plastic horn antenna - Version with adapter flange from DN 100 PP or PP-GF 30 -1 ... 1 bar (-100 ... 100 kPa/-14.5 ... 14.5 psig)

Vessel pressure relating to the flange nominal pressure stage

see supplementary instructions manual "*Flanges according to DIN-EN-ASME-JIS*"

Mechanical stresses

Vibration resistance - Metal jacketed lens antenna 4 g at 5 ... 200 Hz according to EN 60068-2-6 (vibration with resonance)

Vibration resistance - Plastic horn antenna

- With adapter flange 2 g at 5 ... 200 Hz according to EN 60068-2-6 (vibration with resonance)
- with mounting strap 1 g at 5 ... 200 Hz according to EN 60068-2-6 (vibration with resonance)

Shock resistance

100 g, 6 ms according to EN 60068-2-27 (mechanical shock)

Data rinsing air connection - Metal jacketed lens antenna

Max. permissible pressure 6 bar (87.02 psig)

Air volume, depending on pressure (recommended area)

Pressure	Air volume	
	Without reflux valve	With reflux valve
0.2 bar (2.9 psig)	1.7 m ³ /h	-
0.4 bar (5.8 psig)	2.5 m ³ /h	-
0.6 bar (8.7 psig)	2.9 m ³ /h	0.8 m ³ /h
0.8 bar (11.6 psig)	3.3 m ³ /h	1.5 m ³ /h
1 bar (14.5 psig)	3.6 m ³ /h	2.0 m ³ /h
1.2 bar (17.4 psig)	3.9 m ³ /h	2.3 m ³ /h
1.4 bar (20.3 psig)	4.0 m ³ /h	2.7 m ³ /h
1.6 bar (23.2 psig)	4.3 m ³ /h	3.0 m ³ /h
1.8 bar (20.3 psig)	4.5 m ³ /h	3.5 m ³ /h
2 bar (23.2 psig)	4.6 m ³ /h	4.0 m ³ /h

Thread G $\frac{1}{8}$

Closure Threaded plug of 316Ti

Reflux valve - unmounted (as option with non-Ex version, included in the scope of delivery with Ex version)

- Material 316Ti
- Thread G $\frac{1}{8}$

- Seal	FKM (SHS FPM 70C3 GLT), EPDM (COG AP310)
- For connection	G¼
- opening pressure	0.5 bar (7.25 psig)
- Nominal pressure stage	PN 250

Electromechanical data - version IP 66/IP 67

Cable gland M20 x 1.5 or ½ NPT

Wire cross-section (spring-loaded terminals)

- Massive wire, stranded wire	0.2 ... 2.5 mm ² (AWG 24 ... 14)
- Stranded wire with end sleeve	0.2 ... 1.5 mm ² (AWG 24 ... 16)

Display and adjustment module

Display element Display with backlight

Measured value indication

- Number of digits	5
- Size of digits	W x H = 7 x 13 mm

Adjustment elements 4 keys

Protection rating

- unassembled	IP 20
- mounted in the housing without lid	IP 40

Materials

- Housing	ABS
- Inspection window	Polyester foil

Interface to the external display and adjustment unit

Data transmission digital (I²C-Bus)

Configuration, connection cable 4-wire, screened

Cable length max. 25 m

Integrated clock

Date format Day.Month.Year

Time format 12 h/24 h

Time zone Ex factory CET

Rate deviation max. 10.5 min/year

Measurement electronics temperature

Resolution 0.1 °C (1.8 °F)

Accuracy ±1 °C (1.8 °F)

Permissible temperature range -40 ... +85 °C (-40 ... +185 °F)

Voltage supply

Operating voltage

- Version for low voltage	9.6 ... 48 V DC, 20 ... 42 V AC, 50/60 Hz
---------------------------	---

– Version for mains voltage	90 ... 253 V AC, 50/60 Hz
Reverse voltage protection	Integrated
Max. power consumption	4 VA; 2.1 W

Electrical protective measures

Protection rating	IP 66/IP 67 (NEMA 4X)
Overtoltage category	III ⁵⁾
Protection class	I ⁶⁾

Approvals

Instruments with approvals can have different technical specifications depending on the version.

For that reason the associated approval documents of these instruments have to be carefully noted. They are part of the delivery or can be downloaded under www.vega.com, "VEGA Tools" and "Instrument search" as well as under www.vega.com/downloads and "Approvals".

11.2 Radio astronomy stations

The following table shows the geographic position of the radio astronomy stations in Europe:

Country	Name of the Station	Geographic Latitude	Geographic Longitude
Finland	Metsähovi	60°13'04" N	24°23'37" E
	Tuorla	60°24'56" N	24°26'31" E
France	Plateau de Bure	44°38'01" N	05°54'26" E
	Floirac	44°50'10" N	00°31'37" W
Germany	Effelsberg	50°31'32" N	06°53'00" E
Hungary	Penc	47°47'22" N	19°16'53" E
Italy	Medicina	44°31'14" N	11°38'49" E
	Noto	36°52'34" N	14°59'21" E
	Sardinia	39°29'50" N	09°14'40" E
Poland	Krakow- Fort Skala	50°03'18" N	19°49'36" E
Russia	Dmitrov	56°26'00" N	37°27'00" E
	Kalyazin	57°13'22" N	37°54'01" E
	Pushchino	54°49'00" N	37°40'00" E
	Zelenchukskaya	43°49'53" N	41°35'32" E
Spain	Yebes	40°31'27" N	03°05'22" W
	Robledo	40°25'38" N	04°14'57" W
Switzerland	Bleien	47°20'26" N	08°06'44" E
Sweden	Onsala	57°23'45" N	11°55'35" E

⁵⁾ IEC 61010-1

⁶⁾ IEC 61010-1

Country	Name of the Station	Geographic Latitude	Geographic Longitude
UK	Cambridge	52°09'59" N	00°02'20" E
	Darnhall	53°09'22" N	02°32'03" W
	Jodrell Bank	53°14'10" N	02°18'26" W
	Knockin	52°47'24" N	02°59'45" W
	Pickmere	53°17'18" N	02°26'38" W

11.3 Dimensions

The following dimensional drawings represent only an extract of all possible versions. Detailed dimensional drawings can be downloaded at www.vega.com/downloads under "Drawings".

Housing

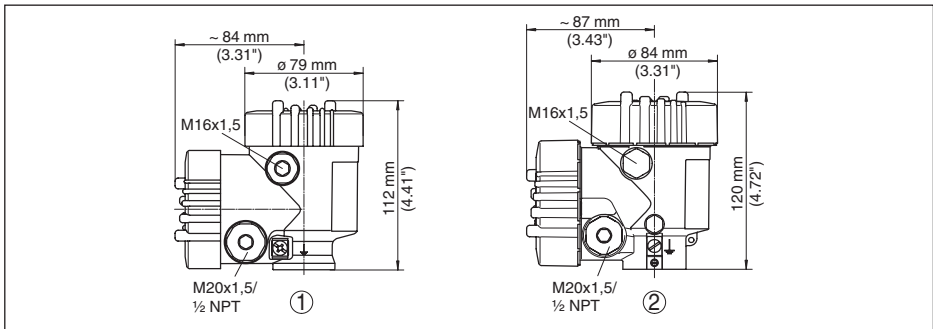

Fig. 50: Dimensions housing - with integrated display and adjustment module the housing is 9 mm/0.35 in higher

- 1 Plastic housing
- 2 Aluminium/Stainless steel housing

VEGAPULS 69, plastic horn antenna with compression flange

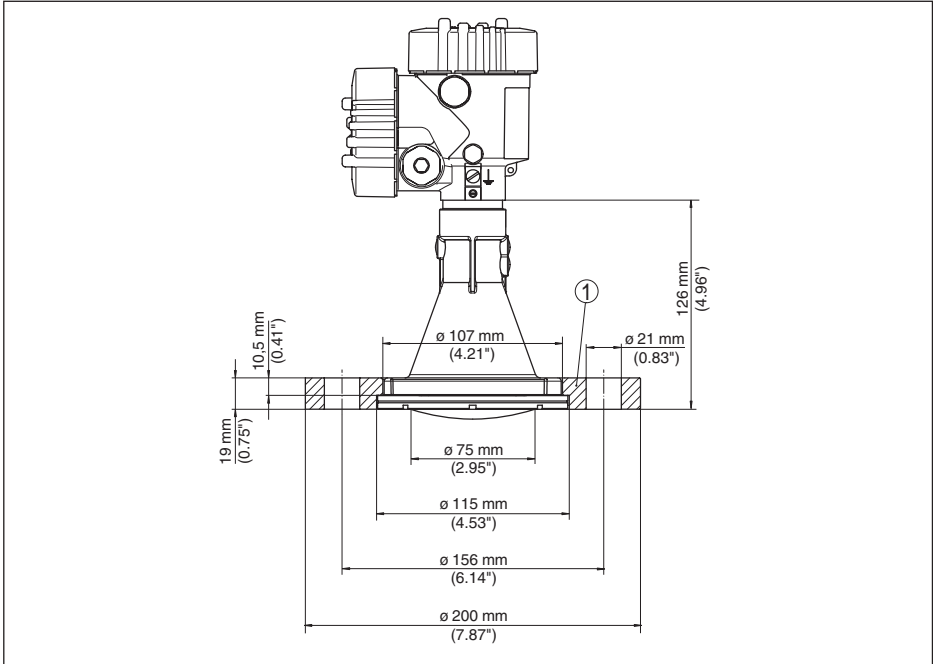

Fig. 51: VEGAPULS 69, plastic horn antenna, compression flange

1 Compression flange

VEGAPULS 69, plastic horn antenna with adapter flange

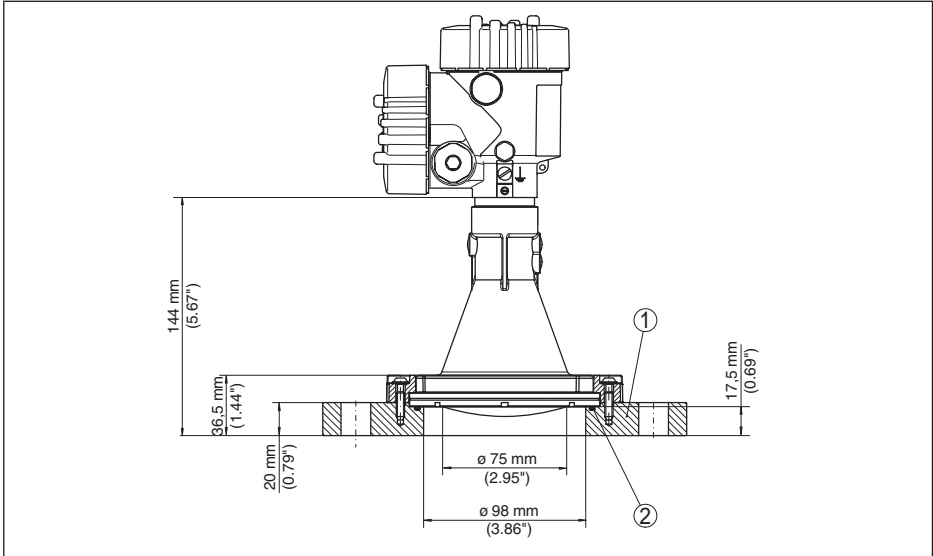

Fig. 52: VEGAPULS 69, plastic horn antenna, adapter flange

VEGAPULS 69, plastic antenna and mounting strap

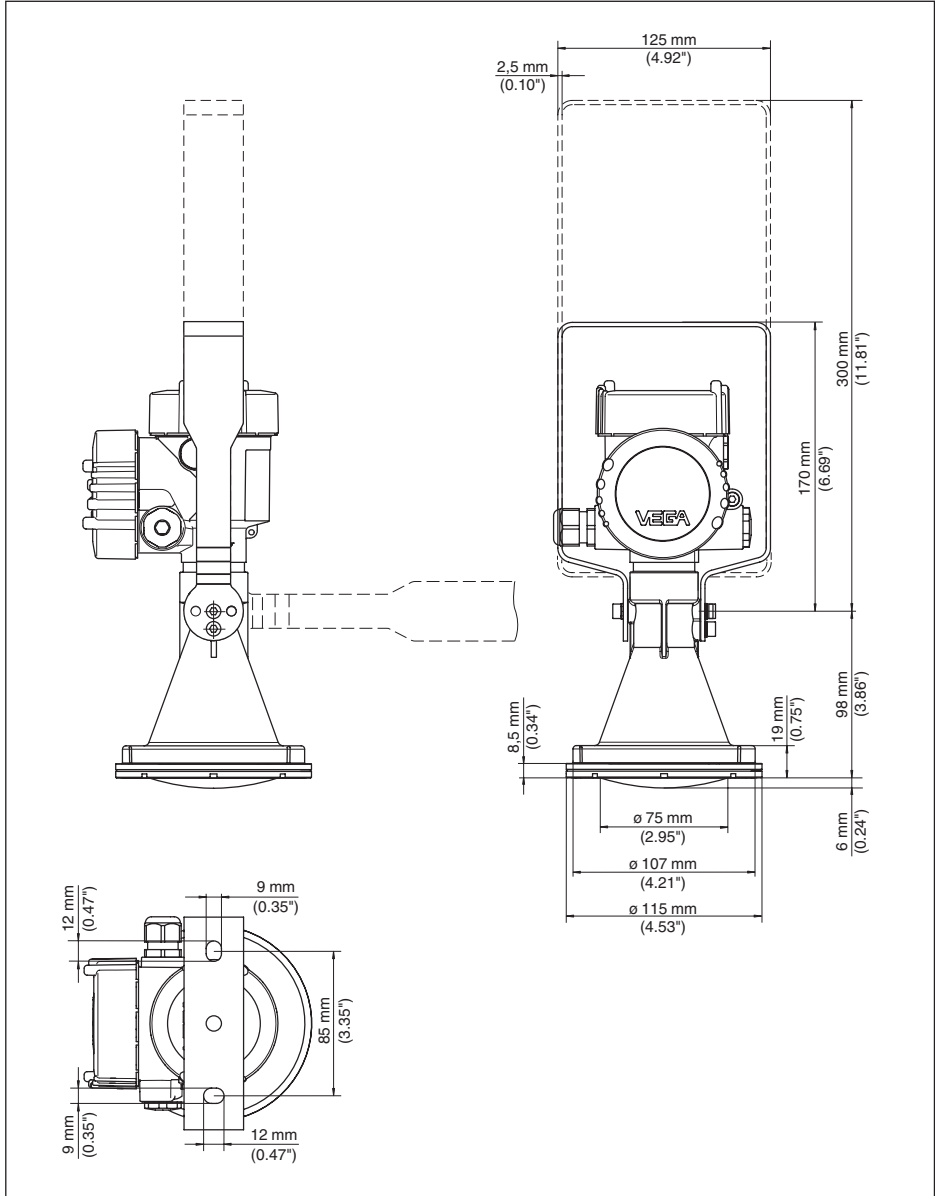

Fig. 53: VEGAPULS 69, plastic antenna and mounting strap in 170 or 300 mm length

47249-EN-140707

VEGAPULS 69, metal jacketed lens antenna

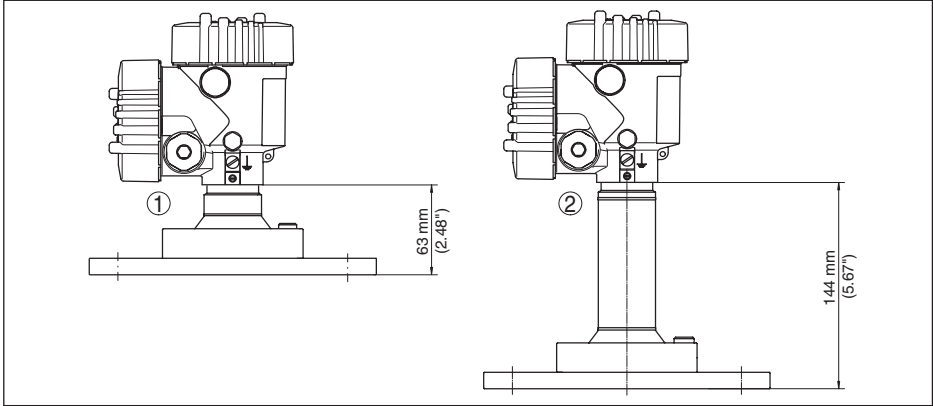

Fig. 54: VEGAPULS 69, metal jacketed lens antenna

VEGAPULS 69, metal jacketed lens antenna and swivelling holder

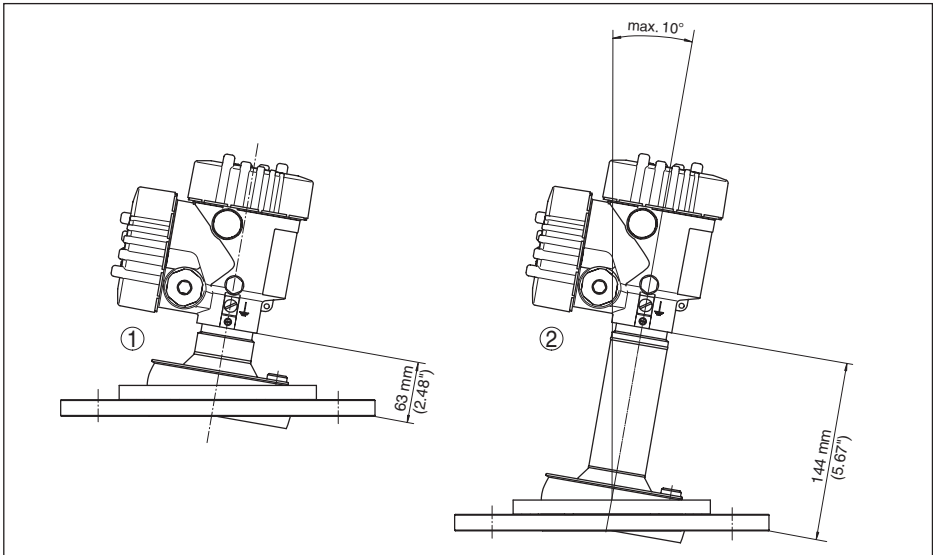

Fig. 55: VEGAPULS 69, metal jacketed lens antenna and swivelling holder

11.4 Industrial property rights

VEGA product lines are global protected by industrial property rights. Further information see www.vega.com.

Only in U.S.A.: Further information see patent label at the sensor housing.

VEGA Produktfamilien sind weltweit geschützt durch gewerbliche Schutzrechte.

Nähere Informationen unter www.vega.com.

Les lignes de produits VEGA sont globalement protégées par des droits de propriété intellectuelle. Pour plus d'informations, on pourra se référer au site www.vega.com.

VEGA líneas de productos están protegidas por los derechos en el campo de la propiedad industrial. Para mayor información revise la página web www.vega.com.

Линии продукции фирмы ВЕГА защищаются по всему миру правами на интеллектуальную собственность. Дальнейшую информацию смотрите на сайте www.vega.com.

VEGA系列产品在全球享有知识产权保护。

进一步信息请参见网站www.vega.com。

11.5 Trademark

All the brands as well as trade and company names used are property of their lawful proprietor/originator.

INDEX

A

Adjustment 40, 41
Adjust the current output 47
Adjust the indication 43

C

Change the language 42
Check output signal 61
Connecting
– To the PC 52
Connection cable 27
Connection procedure 28
Connection technology 28
Copy sensor settings 46
Current output 41
Current output Min./Max. 42
Curve indication
– Echo curve 43

D

Damping 41
Date/Time 45
Default values 46
Deviation 61
Display lighting 43

E

Echo curve memory 56
Echo curve of the setup 44
EDD (Enhanced Device Description) 55
Electronics compartment, double chamber housing 29
Error codes 59
Event memory 56

F

False signal suppression 48
Fault rectification 61
Functional principle 9

G

Grounding 27

H

HART address 49

L

Linearization 49
Lock adjustment 22

M

Main menu 36
Measured value memory 56
Measurement loop name 37
Mounting
– Flange 15
– Strap 13

N

NAMUR NE 107 58, 60

O

Operation
– System 34

P

Peak value indicator 43
Polarisation 16
Protection class 27

R

Repair 65
Replacement parts
– Supplementary electronics 4 ... 20 mA/
HART - four-wire 12
Reset 45

S

Sensor status 43
Service hotline 64
Setup
– Quick setup 35
Shielding 27
Simulation 44
Socket 19
Special parameters 49
Status messages - NAMUR NE 107 57

T

Terminal compartment
– Double chamber housing 30
Type label 8

U

Units 37

V

Vessel installations 23
Vessel insulation 24
Voltage supply 27, 73



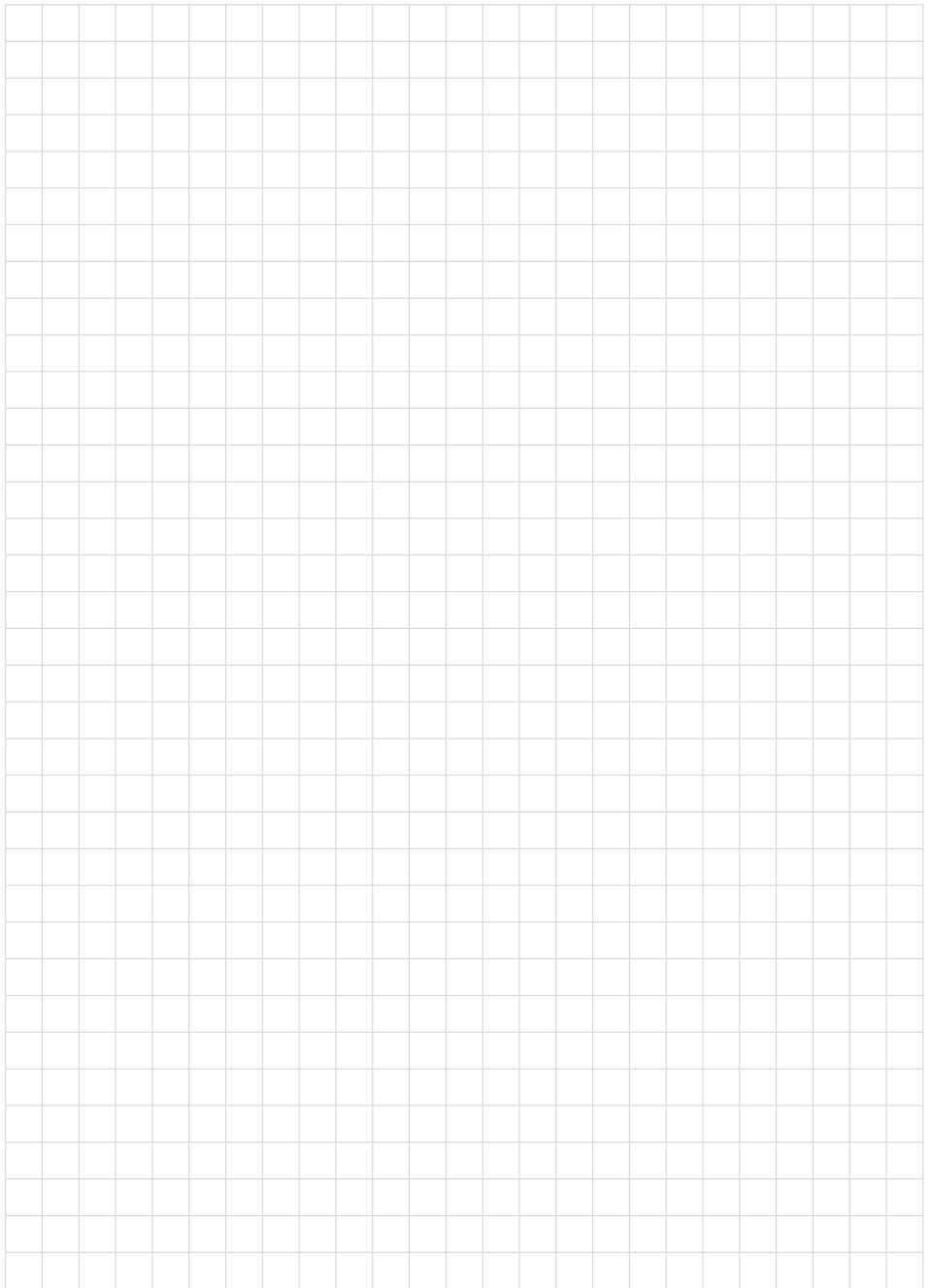

Printing date:

VEGA

All statements concerning scope of delivery, application, practical use and operating conditions of the sensors and processing systems correspond to the information available at the time of printing.

Subject to change without prior notice

© VEGA Grieshaber KG, Schiltach/Germany 2014



47249-EN-140707

VEGA Grieshaber KG
Am Hohenstein 113
77761 Schiltach
Germany

Phone +49 7836 50-0
Fax +49 7836 50-201
E-mail: info.de@vega.com
www.vega.com