

Operating Instructions

VEGACAP 64

with contactless electronic switch

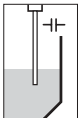

Contents

1	About this document	
1.1	Function	4
1.2	Target group	4
1.3	Symbolism used	4
2	For your safety	
2.1	Authorised personnel	5
2.2	Appropriate use	5
2.3	Warning about misuse	5
2.4	General safety instructions	5
2.5	CE conformity	5
2.6	Safety information for Ex areas	6
2.7	Manufacturer declaration	6
2.8	Environmental instructions	7
3	Product description	
3.1	Configuration	8
3.2	Principle of operation	8
3.3	Adjustment	10
3.4	Storage and transport	10
4	Mounting	
4.1	General instructions	11
4.2	Mounting information	12
5	Connecting to power supply	
5.1	Preparing the connection	14
5.2	Connection steps	14
5.3	Wiring plans, single chamber housing	15
6	Set up	
6.1	General	18
6.2	Adjustment elements	18
6.3	Function chart	22
7	Maintenance and fault rectification	
7.1	Maintenance	23
7.2	Fault rectification	23
7.3	Exchange of the electronics module	24
7.4	Instrument repair	26
8	Dismounting	
8.1	Dismounting steps	27

8.2	Disposal	27
9	Supplement	
9.1	Technical data.	28
9.2	Dimensions	31
9.3	Industrial property rights.	34

1 About this document

1.1 Function

This operating instructions manual has all the information you need for quick setup and safe operation. Please read this manual before you start setup.

1.2 Target group

This operating instructions manual is directed to trained, qualified personnel. The contents of this manual should be made available to these personnel and put into practice by them.

1.3 Symbolism used



Information, tip, note

This symbol indicates helpful additional information.



Caution, warning, danger

This symbol informs you of a dangerous situation that could occur. Ignoring this cautionary note can impair the person and/or the instrument.



Ex applications

This symbol indicates special instructions for Ex applications.



List

The dot set in front indicates a list with no implied sequence.



Action

This arrow indicates a single action.



Sequence

Numbers set in front indicate successive steps in a procedure.

2 For your safety

2.1 Authorised personnel

All operations described in this operating instructions manual must be carried out only by trained specialist personnel authorised by the operator. For safety and warranty reasons, any internal work on the instruments must be carried out only by personnel authorised by the manufacturer.

2.2 Appropriate use

VEGACAP 64 is a sensor for level detection.

Detailed information on the application range of VEGACAP 64 is available in chapter "*Product description*".

2.3 Warning about misuse

Inappropriate or incorrect use of the instrument can give rise to application-specific hazards, e.g. vessel overfill or damage to system components through incorrect mounting or adjustment.

2.4 General safety instructions

VEGACAP 64 is a high-tech instrument requiring the strict observance of standard regulations and guidelines. The user must take note of the safety instructions in this operating instructions manual, the country-specific installation standards (e.g. the VDE regulations in Germany) as well as all prevailing safety regulations and accident prevention rules.

2.5 CE conformity

VEGACAP 64 is in CE conformity with EMC (89/336/EWG) and LVD (73/23/EWG).

Conformity has been judged acc. to the following standards:

- EMC:
 - Emission EN 61326: 2004 (class B)
 - Susceptibility EN 61326: 2004/Supplement A
- LVD: EN 61010-1: 2001

2.6 Safety information for Ex areas

Please note the Ex-specific safety information for installation and operation in Ex areas. These safety instructions are part of the operating instructions manual and come with the Ex-approved instruments.

2.7 Manufacturer declaration

In conformity with DIN EN 60079-14/2004, para. 5.2.3, point c1, the capacitive probe VEGACAP 64 is suitable for use in zone 2.

The operator must use the instrument correctly and follow the specifications of the following documents:

- this operating instructions manual
- this manufacturer declaration (24643)
- the corresponding installation regulations

Max. increase of the surface temperature during operation:
40 K (individual components in the instrument)

With an ambient temperature of +70°C (+158°F) on the housing and a process temperature of +70°C (+158°F), the max. ambient temperature during operation is +110°C (+230°F).

Measures for maintaining explosion protection during operation:

- Operate the instrument in the range of the specified electrical limit values. Permissible supply voltage: see "*Technical data*"
- Mount and operate the instrument in such a way that no ignition danger is expected by electrostatic charges. The process fitting, the plastic-coated/covered probe part or the housing are made of electrically non-conductive plastic (depending on the version).
- Make sure that the seal is mounted correctly between lower part of the housing and cover. Screw the cover on tightly.
- Make sure that there is no explosive atmosphere, if you want to operate the instrument with open cover
- Make sure that the cable gland is tight and strain-relieved. The outer diameter of the connection cable must be adapted to the cable gland. Tighten the pressure screw of the cable gland carefully.
- Cover unused openings for cable glands tightly

- Mount the instrument in such a position that the sensor cannot touch the vessel wall or vessel installations. Keep the influences of product movements in the vessel in mind.
- The surface temperature on the housing must not exceed the ignition temperature of the concerned explosive atmosphere

This instrument was judged by a person that fulfils the requirements acc. to DIN EN 60079-14.

2.8 Environmental instructions

Protection of the environment is one of our most important duties. That is why we have introduced an environment management system with the goal of continuously improving company environmental protection. The environment management system is certified acc. to DIN EN ISO 14001.

Please help us fulfil this obligation by observing the environmental instructions in this manual:

- Chapter "*Storage and transport*"
- Chapter "*Disposal*"

3 Product description

3.1 Configuration

Scope of delivery

The scope of delivery encompasses:

- VEGACAP 64 level sensor
- Documentation
 - this operating instructions manual
 - Ex specific safety instructions (with Ex versions), if necessary further certificates

Components

VEGACAP 64 consists of the following components:

- Housing cover
- Housing with electronics
- Process fitting with electrode

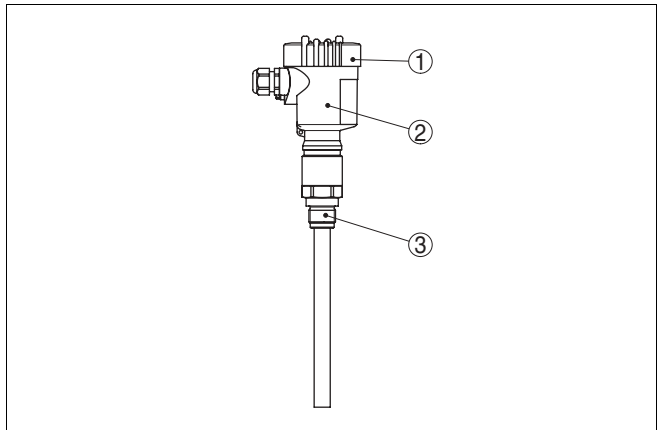

Fig. 1: VEGACAP 64 - with plastic housing

- 1 Housing cover
- 2 Housing with electronics
- 3 Process fitting

3.2 Principle of operation

Area of application

VEGACAP 64 is a level sensor with fully insulated capacitive electrode for level detection.

VEGACAP 64 is very rugged and maintenance-free and can be used in all areas of industrial process technology.

Fully insulated probes such as VEGACAP 64 are preferably used in liquids.

VEGACAP 64 is particularly suitable for use in very adhesive, conductive liquids.

Typical applications are overfill and dry run protection.

The capacitive measuring principle places no special requirements on installation. Hence, many different applications can be equipped with VEGACAP 64.

The instrument can also be used problem-free in corrosive products.

Physical principle

The probe, the measured product and the vessel wall form an electrical capacitor. The capacitance is influenced by three main factors.

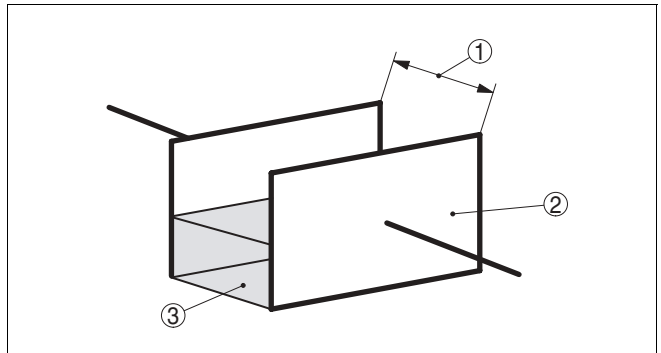

Fig. 2: Functional principle - Plate capacitor

1 Distance between the electrode surfaces

2 Size of the electrode surfaces

3 Type of dielectric between the electrodes

The probe and the vessel wall are the capacitor plates. The measured product is the dielectric. Due to the higher dielectric constant (DK value) of the product compared to air, the capacitance increases as the probe is gradually covered.

The capacitance change is converted by the oscillator into a switching command.

Supply

VEGACAP 64 is a compact instrument, i.e. it can be operated without external evaluation system. The integrated electronics evaluates the level signal and outputs a switching signal. With this switching signal, a connected device can be operated directly (e.g. a warning system, a PLC, a pump etc.).

The exact range of the supply voltage is specified in the "*Technical data*" in the "*Supplement*".

3.3 Adjustment

The probe can be adapted to the dielectric constant of the product directly on the electronics module.

A switching command can be triggered when the probe is covered or laid bare.

On the electronics module you will find the following indicating and adjustment elements:

- signal lamp for indication of the switching condition (green/red)
- Potentiometer for switching point adaptation
- DIL switch for measuring range selection
- DIL switch for mode adjustment

3.4 Storage and transport

Packaging

Your instrument was protected by packaging during transport. Its capacity to handle normal loads during transport is assured by a test acc. to DIN 55439.

The packaging of standard instruments consists of environment-friendly, recyclable cardboard. For special versions, PE foam or PE foil is also used. Dispose of the packaging material via specialised recycling companies.

Storage and transport temperature

- Storage and transport temperature see "*Supplement - Technical data - Ambient conditions*"
- Relative humidity 20 ... 85 %

4 Mounting

4.1 General instructions

- Switching point** In general, VEGACAP 64 can be mounted in any position. The instrument must be mounted in such a way that the probe is at the height of the requested switching point.
- Handling** With screwed versions, the housing must not be used for screwing in! Tightening can cause damages on the locking piston of the housing.
- To screw in, use the hexagon above the thread.
- Moisture** Use the recommended cable (see chapter "Connecting to power supply") and tighten the cable gland.
- You can give your VEGACAP 64 additional protection against moisture penetration by leading the connection cable downward in front of the cable entry. Rain and condensation water can thus drain off. This applies mainly to mounting outdoors, in areas where moisture is expected (e.g. by cleaning processes) or on cooled or heated vessels.

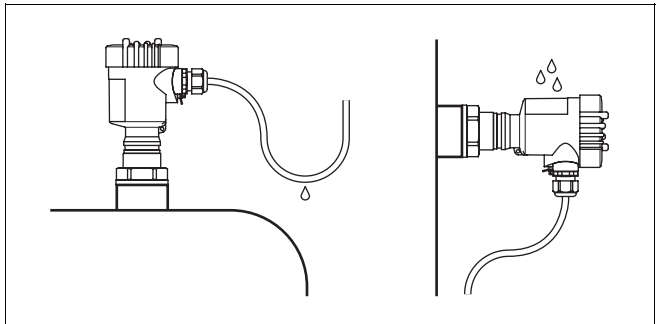

Fig. 3: Measures against moisture penetration

- Transport** Do not hold VEGACAP 64 on the probe. Especially with heavy flange versions or long rod versions, the sensor can be damaged simply by the weight of the instrument.
- Pressure/Vacuum** The process fitting must be sealed if there is gauge or low pressure in the vessel. Before use, check if the seal material is resistant against the measured product and the process temperature.

4.2 Mounting information

Agitators and fluidization

Agitators, equipment vibration, etc., can cause the level switch to be subjected to strong lateral forces. For this reason, do not use an overly long probe for VEGACAP 64, but check if you can mount a short level switch on the side of the vessel in horizontal position.

Extreme vibration caused by the system, e.g. due to agitators or turbulence in the vessel from fluidization can cause the probe of VEGACAP 64 to vibrate in resonance. If a longer rod version is necessary, you can secure the probe by fastening a suitable brace or guy directly above the end of the rod.

Inflowing material

If VEGACAP 64 is mounted in the filling stream, unwanted false measurements may be generated. Mount VEGACAP 64 at a location in the vessel where no disturbing influence from e. g. filling openings, agitators, etc. can occur.

This applies particularly to instrument versions with a longer probe.

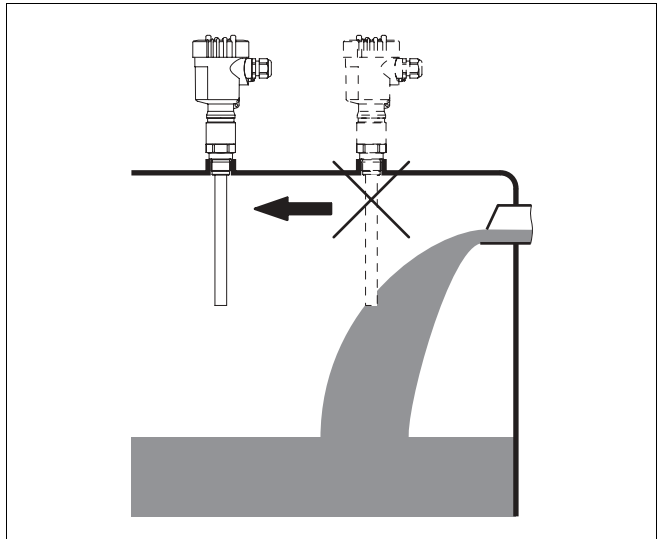

Fig. 4: Inflowing material

Socket

The probe should protrude into the vessel to avoid buildup. For that reason, avoid using mounting bosses for flanges and screwed fittings. This applies particularly to use with adhesive products.

5 Connecting to power supply

5.1 Preparing the connection

Note safety instructions

Always observe the following safety instructions:

- Connect only in the complete absence of line voltage

Select power supply

Connect the power supply acc. to the following diagrams. Oscillator CP60C is designed in protection class 1. To maintain this protection class, it is absolutely necessary that the ground conductor is connected to the internal ground terminal. Take note of the general installation regulations. As a rule, connect VEGACAP 64 to vessel ground (PA), or in case of plastic vessels, to the next ground potential. On the side of the housing there is a ground terminal between the cable entries. This connection serves to drain off electrostatic charges.

The data for power supply are stated in the "*Technical data*" in the "*Supplement*".

Select connection cable

VEGACAP 64 is connected with standard cable with round wire cross section. An outer cable diameter of 5 ... 9 mm (0.2 ... 0.35 in) ensures the seal effect of the cable entry.

If cable with a different diameter or wire cross section is used, exchange the seal or use an appropriate cable connection.

5.2 Connection steps



With Ex instruments, the housing cover may only be opened if there is no explosive atmosphere present.

Proceed as follows:

- 1 Unscrew the housing cover
- 2 Loosen compression nut of the cable entry
- 3 Remove approx. 10 cm (4 in) of the cable mantle, strip approx. 1 cm (0.4 in) insulation from the ends of the individual wires
- 4 Insert the cable into the sensor through the cable entry
- 5 Lift the opening levers of the terminals with a screwdriver (see following illustration)
- 6 Insert the wire ends into the open terminals according to the wiring plan

- 7 Press down the opening levers of the terminals, you will hear the terminal spring closing
 - 8 Check the hold of the wires in the terminals by lightly pulling on them
 - 9 Tighten the compression nut of the cable entry, the seal ring must completely encircle the cable
 - 10 Screw the housing cover back on
- The electrical connection is finished.



Fig. 5: Connection steps 5 and 6

5.3 Wiring plans, single chamber housing

Housing overview

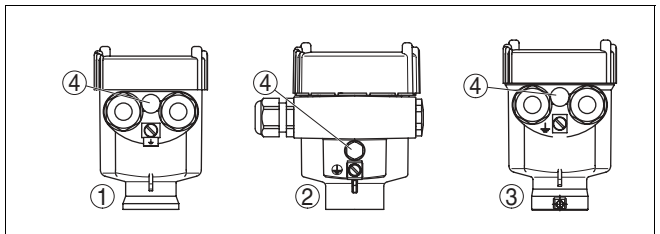

Fig. 6: Material versions, single chamber housing

- 1 Plastic (not with dust-Ex)
- 2 Aluminium
- 3 Stainless steel
- 4 Filter element for pressure compensation

Electronics and connection compartment

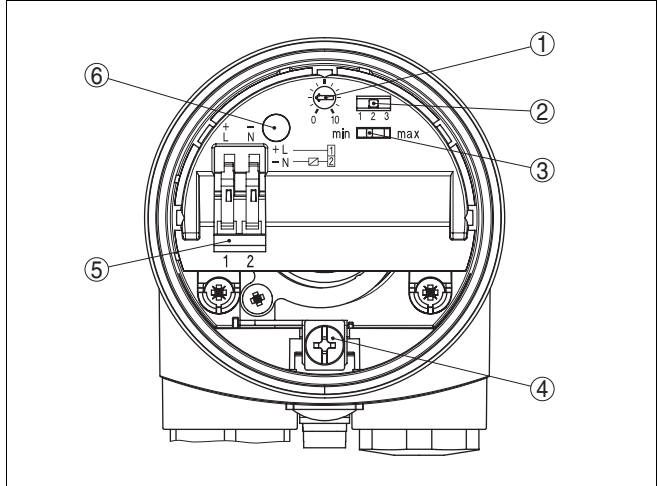

Fig. 7: Electronics and connection compartment

- 1 Potentiometer for switching point adaptation
- 2 DIL switch for measuring range selection
- 3 DIL switch for mode adjustment
- 4 Ground terminal
- 5 Terminals
- 6 Control lamp

Wiring plan

We recommend connecting VEGACAP 64 in such a way that the switching circuit is open when there is a level signal, line break or failure (safe condition).

The contactless electronic switch is always shown in non-operative condition.

The instrument is used for direct control of relays, contactors, magnet valves, warning lights, horns etc. It must not be operated without an intermediately connected load, because the electronics would be destroyed if connected directly to the mains. It is not suitable for connection to low voltage PLC inputs.

The domestic current briefly below 1 mA after switching off the load so that contactors the holding current of which is lower than the permanently flowing domestic current of the electronics are nevertheless switched off reliably.

When VEGACAP 64 is used as part of an overfill protection system acc. to WHG, also note the regulations of the general type approval.

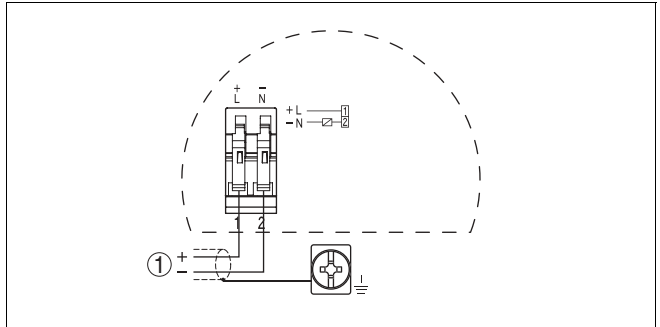

Fig. 8: Wiring plan
1 Voltage supply

6 Set up

6.1 General

The numbers in brackets refer to the following illustrations.

Function/Configuration

On the electronics module you will find the following indicating and adjustment elements:

- Potentiometer for switching point adaptation
- DIL switch for measuring range selection
- DIL switch for mode adjustment - min./max.
- Control lamp



Note:

As a rule, always set the mode with the mode switch (3) before starting setup VEGACAP 64. The switching output will change if you set the mode switch (3) afterwards. This could possibly trigger other connected instruments or devices.

6.2 Adjustment elements

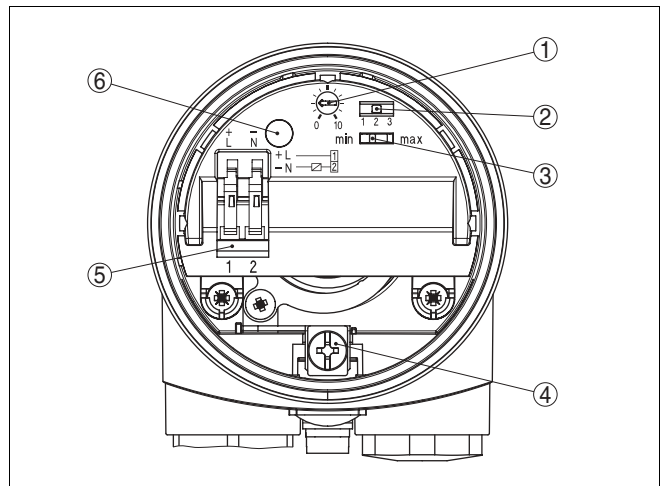

Fig. 9: Oscillator - Contactless electronic switch

- 1 Potentiometer for switching point adaptation
- 2 DIL switch for measuring range selection
- 3 DIL switch for mode adjustment
- 4 Ground terminal
- 5 Terminals
- 6 Control lamp

The switching status of the electronics can be checked with closed housing (only plastic housing), see "*Function chart*".

**Note:**

Screw the housing cover tightly to the point where the inspection glass is above the control lamp (LED).

To adjust VEGACAP 64, first of all remove the housing cover.

Switching point adaptation (1)

You can adapt the switching point to the solid with the potentiometer.

As a default setting, the potentiometer of VEGACAP 64 is set to mid position. To make the instrument less sensitive, turn the potentiometer clockwise. VEGACAP 64 can then detect products with high dielectric value (e.g. water) more reliably.

To make the instrument more sensitive, turn the potentiometer anticlockwise. VEGACAP 64 can then detect products with low dielectric value (e.g. oil) more reliably.

Measuring range selection switch (2)

With the potentiometer (1) and the meas. range selection switch (2) you can change the switching point of the probe or adapt the sensitivity of the probe to the electrical properties of the product and the conditions in the vessel. This is necessary so that the level switch can also reliably detect products e.g. with very low or very high dielectric value.

Range 1: 0 ... 20 pF

Range 2: 0 ... 85 pF

Range 3: 0 ... 450 pF

Mode adjustment (3)

With the mode switch (3) you can change the switching status of the output. The required mode can be set acc. to the function chart.

max. - max. detection or overflow protection

min. - min. detection or dry run protection.

We recommend connecting acc. to the quiescent current principle (contactless electronic switch is open when the switching point is reached) because the contactless electronic switch takes on the same (safe) condition if a failure is detected.

Signal lamp (6)

Control lamp for indication of the switching condition.

- green = switch closed
- red = switch open
- red (flashing) = failure

Switching point adjustment

The adjustment of the switching point is only possible in installed condition.

The specifications in parenthesis refer to the above illustration.

Mode max. [mode min.]**Horizontally mounted probes, angled probes**

- 1 Set mode switch (3) to mode max [min.].
- 2 Set meas. range selection switch (2) to position 1.
- 3 Make sure the probe is not covered by the medium.
- 4 Turn the potentiometer (1) to 0; the control lamp (6) lights red [lights green].
- 5 To determine the empty switch point, turn the potentiometer (1) very slowly clockwise until the control lamp lights green [lights red]. If the control lamp still lights red [lights green], then you have to set the meas. range selection switch (2) to the next higher stage and repeat the setting with the potentiometer (1) until the control lamp lights green [lights red].
- 6 Note the position of the potentiometer (1).
In some cases the lowest range (range 1 = highest sensitivity) is not sufficient to adjust the full switch point. This would make another filling procedure necessary.
For this reason we recommend setting and noting the empty switch point in all three meas. ranges. Set the meas. range selection switch (2) to the next higher range and repeat the setting. Also note the values for the next ranges.
- 7 Reset meas. range selection switch (2) to the next lower range in which the control lamp lights green [lights red].
- 8 Fill the vessel until the probe is completely covered.
- 9 Turn the potentiometer (1) very slowly clockwise until the control lamp lights green [lights red].
- 10 Note the position of the potentiometer (1). We recommend documenting the value of the empty switch point and the full switch point as well as the range.
- 11 If the control lamp does not light green [light red], then you have to set the meas. range switch (2) to the next higher stage and repeat the setting with the potentiometer until the control lamp lights green [lights red].

12 Set the potentiometer (1) to the average value of the two noted values.

The measuring system is now ready for operation.

	Empty adjustment	Full adjustment
range 1		
range 2		
range 3		

Tab. 16: Note the position of the potentiometer.



Note:

If you do not find the full switch point in one of the ranges, we recommend setting the meas. range selection switch (2) to the lowest range in which you have found the empty switch point. Set the potentiometer (1) to the average value between empty switch point and 10.

Vertically mounted probes

Mode max. (max. detection)

- 1 Set mode switch (3) to mode max.
- 2 Set meas. range selection switch (2) to range 1.
- 3 Fill the vessel up to the requested level.
- 4 Turn the potentiometer (1) to 10; the control lamp (6) lights green.
- 5 Turn the potentiometer (1) very slowly anticlockwise until the control lamp (6) lights red. If the control lamp does not light red, then you have to set the meas. range selection switch (2) to the next higher stage and repeat the setting with the potentiometer (1) until the control lamp lights red.

The measuring system is now ready for operation.

















Mode min. (min. detection)

- 1 Set mode switch (3) to mode min.
- 2 Set meas. range selection switch (2) to position 1.
- 3 Lower the level to the requested min. level.
- 4 Turn the potentiometer (1) to 0; the control lamp (6) lights green.
- 5 Turn the potentiometer (1) very slowly clockwise until the control lamp (6) lights red. If the control lamp does not light red, set the meas. range selection switch (2) to the next higher stage and repeat the setting with the potentiometer (1) until the control lamp lights red.

The measuring system is now ready for operation.

6.3 Function chart

The following chart provides an overview of the switching conditions depending on the adjusted mode and level.

	Level	Switching status	Control lamp
max. mode Overfill protection		 Switch closed	 Green
max. mode Overfill protection		 Switch open	 Red
min. mode Dry run protection		 Switch closed	 Green
min. mode Dry run protection		 Switch open	 Red
Failure of the supply voltage (min./max. mode)	any	 Switch open	
Failure	any	 Switch open	 flashes red

7 Maintenance and fault rectification

7.1 Maintenance

When used as directed in normal operation, VEGACAP 64 is completely maintenance-free.

7.2 Fault rectification

Causes of malfunction

VEGACAP 64 offers maximum reliability. Nevertheless faults can occur during operation. These may be caused by the following, e.g.:

- Sensor
- Process
- Supply
- Signal processing

Fault rectification

The first measures to be taken are checking the output signal. By doing this, the reasons can be determined in many cases and faults can be rectified.

24 hour service hotline

Should the following measures not be successful, please call in urgent cases the VEGA service hotline under the phone number **+49 1805 858550**.

The hotline is available to you 7 days a week round-the-clock. Since we offer this service world-wide, the support is only available in the English language. The service is free of charge, only the standard telephone costs will be charged.

Checking the switching signal

- ? VEGACAP 64 signals "covered" when the vibrating element is not submerged (overflow protection)
- ? VEGACAP 64 signals "uncovered" when the vibrating element is submerged (dry run protection)
 - Supply voltage too low
 - Check the power supply
 - Electronics defective
 - Press the mode switch (min./max.). If the instrument then changes the mode, the instrument may be mechanically damaged. Should the switching function in the correct mode still be faulty, return the instrument for repair.
 - Press the mode switch. If the instrument then does not change the mode, the oscillator may be defective. Exchange the oscillator.

- Check if there is buildup on the probe, and if so, remove it.
 - Unfavourable installation location
 - Mount the instrument at a location in the vessel where no dead zones or mounds can form.
 - Check if the probe is covered by buildup on the socket.
 - Wrong mode selected
 - Set the correct mode on the mode switch (max.: overflow protection; min.: dry run protection). Wiring should be carried out acc. to the quiescent current principle.
- ?
- Signal lamp flashes red
 - Electronics has detected a failure
 - Exchange instrument or return it for repair

7.3 Exchange of the electronics module

In general, all oscillators of series CP60 can be interchanged. If you want to use an oscillator with a different signal output, you can download the corresponding operating instructions manual from our homepage under Downloads.

Proceed as follows:

- 1 Switch off power supply
- 2 Unscrew the housing cover
- 3 Lift the opening levers of the terminals with a screwdriver
- 4 Pull the connection cables out of the terminals
- 5 Loosen the two screws with a Phillips screwdriver (size 1)

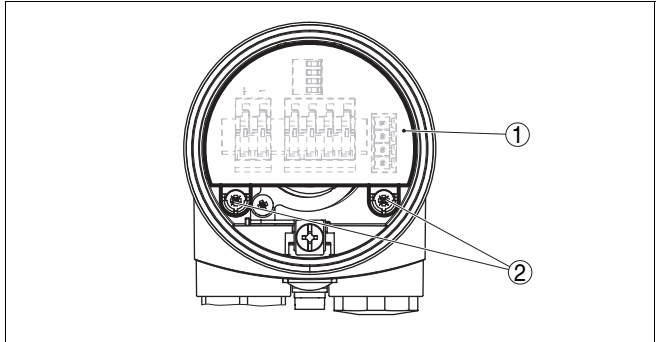

Fig. 10: Loosen the screws

- 1 Electronics module
- 2 Screws (2 pcs.)

- 6 Remove the old oscillator
- 7 Compare the new oscillator with the old one. The type label of the oscillator must correspond to that of the old oscillator. This applies particularly to instruments used in hazardous areas.
- 8 Compare the settings of the two oscillators. Set the adjustment elements of the new oscillator to the settings of the old oscillator.



Information:

Make sure that the housing is not rotated during the electronics exchange. Otherwise the plug may be in a different position later.

- 9 Insert the oscillator carefully. Make sure that the plug is in the correct position.
 - 10 Screw in and tighten the two screws with a Phillips screwdriver.
 - 11 Insert the wire ends into the open terminals according to the wiring plan
 - 12 Press down the opening levers of the terminals, you will hear the terminal spring closing
 - 13 Check the hold of the wires in the terminals by lightly pulling on them
 - 14 Check the tightness of the cable entry. The seal ring must completely encircle the cable.
 - 15 Screw the housing cover back on
- The electronics exchange is finished.

7.4 Instrument repair

If a repair is necessary, please proceed as follows:

From our homepage in the Internet www.vega.com, you can download a return form (23 KB) under: "*Downloads – Forms and Certificates – Repair form*"

By doing this you help us carry out the repair quickly and without having to call back for needed information.

- Print and fill out one form per instrument
- Clean the instrument and pack it damage-proof
- Attach the completed form and possibly also a safety data sheet to the instrument
- Please contact your respective agency for the address of your return shipment!

8 Dismounting

8.1 Dismounting steps

**Warning:**

Before dismounting, be aware of dangerous process conditions such as e.g. pressure in the vessel, high temperatures, corrosive or toxic products etc.

Take note of chapters "*Mounting*" and "*Connecting to power supply*" and carry out the listed steps in reverse order.

8.2 Disposal

VEGACAP 64 consists of materials which can be recycled by specialised recycling companies. We have purposely designed the electronic modules to be easily separable.

WEEE directive 2002/96/EG

This instrument is not subject to the WEEE directive 2002/96/EG and the respective national laws (in Germany, e.g. ElektroG). Pass the instrument directly on to a specialised recycling company and do not use the municipal collecting points. These may only be used for privately used products acc. to the WEEE directive.

Correct disposal avoids negative effects to persons and environment and ensures recycling of useful raw materials.

Materials: see "*Technical data*"

If you cannot dispose of the instrument properly, please contact us about disposal methods or return.

9 Supplement

9.1 Technical data

General data

Material 316L corresponds to 1.4404 or 1.4435

Materials, wetted parts

– Process fitting - Thread	316L
– Process fitting - Flange	316L
– Process seal	Klingsil C-4400
– insulation (fully insulated)	PTFE
– Probe (rod PFTE fully insulated ø 16 mm/ø 0.63 in)	316L

Materials, non-wetted parts

– Housing	plastic PBT (Polyester), Alu-die casting powder-coated, 316L
– Seal ring between housing and housing cover	NBR (stainless steel housing), silicone (Alu/plastic housing)
– Ground terminal	316L

Weights

– with plastic housing	1150 g (40 oz)
– with Aluminium housing	1600 g (56 oz)
– with stainless steel housing	1950 g (69 oz)
– Rod weight ø 16 mm (ø 0.63 in)	1100 g/m (12 oz/ft)

Sensor length (L)	0.2 ... 6 m (0.7 ... 20 ft)
Max. lateral load	10 Nm (7.4 lbf ft)
Max. torque (process fitting thread)	100 Nm (73 lbf ft)

Output variable

Output	Contactless electronic switch
Modes (adjustable)	min./max.
Integration time	
– when immersed	approx. 0.7 s
– when laid bare	approx. 0.7 s
– in case of failure	approx. 1 s

Ambient conditions

Ambient temperature on the housing	-40 ... +80°C (-40 ... +176°F)
Storage and transport temperature	-40 ... +80°C (-40 ... +176°F)

Process conditions

Process pressure	-1 ... 64 bar/-100 ... 6400 kPa (-14.5 ... 928 psi)
Process temperature VEGACAP 64 of 316L	-50 ... +150°C (-58 ... +302°F)
Process temperature (thread or flange temperature) with temperature adapter (option)	-50 ... +200°C (-58 ... +392°F)

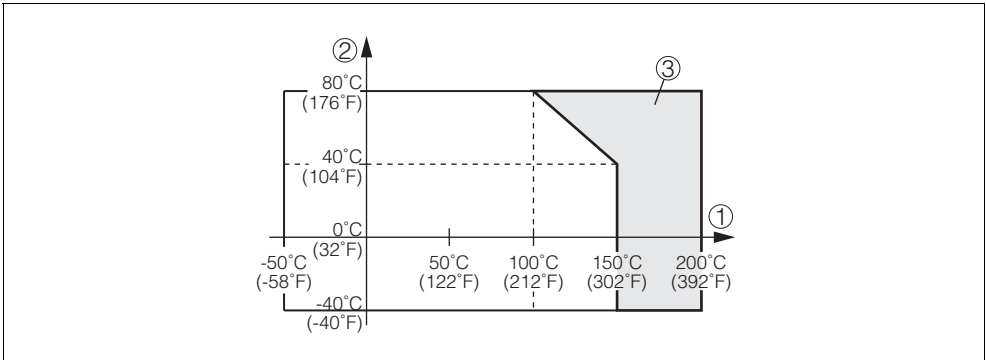

Fig. 11: Ambient temperature - Product temperature

- 1 Product temperature
- 2 Ambient temperature
- 3 Temperature range with temperature adapter

Dielectric figure >1.5

Electromechanical data

Cable entry/plug (dependent on the version)

- Single chamber housing
 - 1x cable entry M20x1.5 (cable-ø5 ... 9 mm), 1x blind stopper M20x1.5, attached 1x cable entry M20x1.5
 - or:
 - 1x cable entry ½ NPT, 1x blind stopper ½ NPT, 1x cable entry ½ NPT
 - or:
 - 1x plug M12x1, 1x blind stopper M20x1.5 for wire cross section up to 1.5 mm² (0.0023 in²)

Spring-loaded terminals

Adjustment elements

Mode switch

- min. min. detection or dry run protection
- max. max. detection or overflow protection

DIL switch for measuring range selection

- range 1 0 ... 20 pF
- range 2 0 ... 85 pF
- range 3 0 ... 450 pF

Trim potentiometer

Switching point adaptation

Voltage supply

Supply voltage

20 ... 253 V AC, 50/60 Hz, 20 ... 253 V DC

Domestic current requirement

approx. 3 mA (via load circuit)

Load current

- min. 10 mA
 - max. 400 mA (with I >300 mA the ambient temperature can be max. +60°C/+140°F) max. 4 A up to 40 ms
-

Electrical protective measures

Protection

IP 66/IP 67

Overvoltage category

III

Protection class

I

Approvals¹⁾

Overflow protection acc. to WHG

Ship approvals

¹⁾ Deviating data with Ex applications: see separate safety instructions.

9.2 Dimensions

VEGACAP 64²⁾

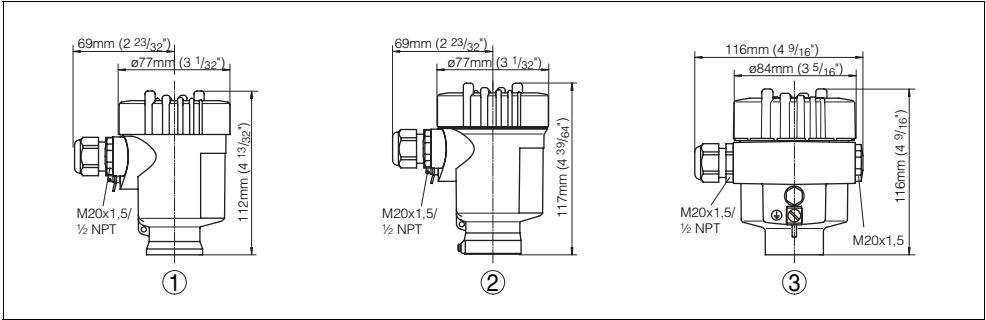

Fig. 12: Housing versions

- 1 Plastic housing
- 2 Stainless steel housing
- 3 Aluminium housing

²⁾ All dimensions in mm (inch).

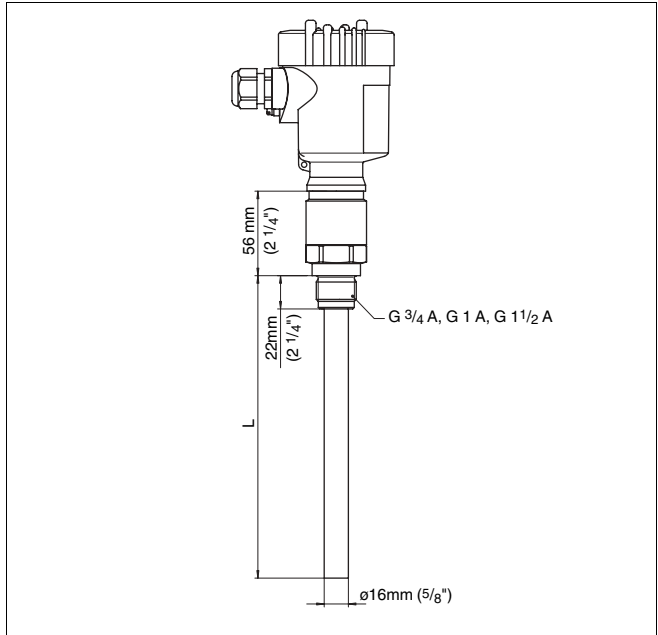

Fig. 13: VEGACAP 64 - Threaded version G1 A
 L = Sensor length, see "Technical data"

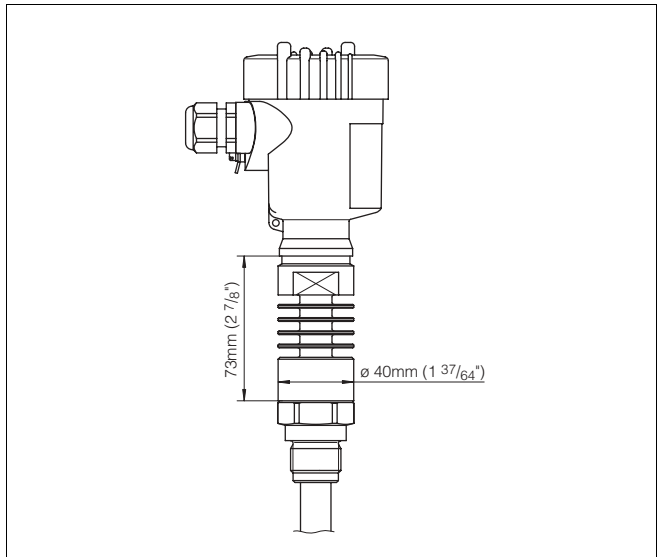

Fig. 14: Temperature adapter

9.3 Industrial property rights

VEGA product lines are global protected by industrial property rights.

Further information see <http://www.vega.com>.

Only in U.S.A.: Further information see patent label at the sensor housing.

VEGA Produktfamilien sind weltweit geschützt durch gewerbliche Schutzrechte.

Nähere Informationen unter <http://www.vega.com>.

Les lignes de produits VEGA sont globalement protégées par des droits de propriété intellectuelle.

Pour plus d'informations, on pourra se référer au site <http://www.vega.com>.

VEGA líneas de productos están protegidas por los derechos en el campo de la propiedad industrial.

Para mayor información revise la pagina web <http://www.vega.com>.

Линии продукции фирмы ВЕГА защищаются повсему миру правами на интеллектуальную собственность.

Дальнейшую информацию смотрите на сайте <http://www.vega.com>.

德（VEGA）系列产品在全球享有知保。
一步信息网站<<http://www.vega.com>>。



VEGA Grieshaber KG
Am Hohenstein 113
77761 Schiltach
Germany
Phone +49 7836 50-0
Fax +49 7836 50-201
E-mail: info@de.vega.com
www.vega.com



All statements concerning scope of delivery, application, practical use and operating conditions of the sensors and processing systems correspond to the information available at the time of printing.

© VEGA Grieshaber KG, Schiltach/Germany 2006