



PSN90 & PSN100 Operating Instructions



CONSTRUCTION PRODUCTS

Unpacking the PSN90/PSN100 Strip Nailer



Check contents:

- ▶ Strip Nailer
- ▶ Safety Glasses
- ▶ Allen Keys
- ▶ PSN90/PSN100 Operating Manual
- ▶ General Safety Operating Manual

Daily Maintenance



Check for:

1. Smooth safety yoke movement
2. Trigger movement
3. Excessively worn or cracked handle
4. All screws and bolts are tight

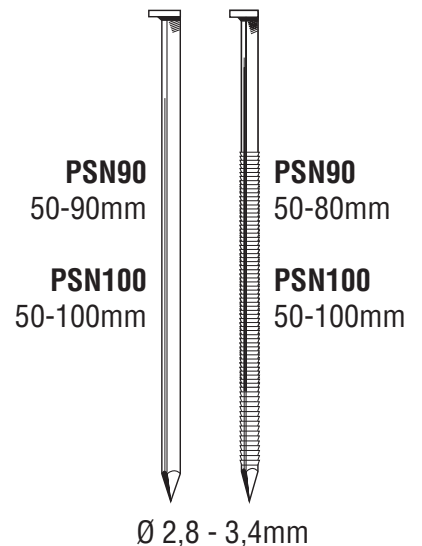
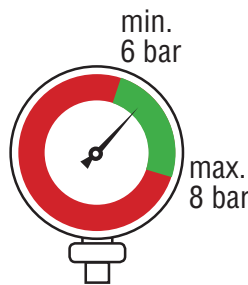
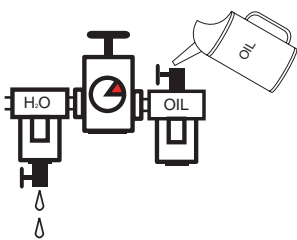

Check contents:

D	Prüfen Sie den Inhalt: <ul style="list-style-type: none">▶ Streifenagler▶ Schutzbrille▶ Schlüssel für Innensechskantschrauben▶ PSN90/PSN100 bedienungsanleitung▶ Allgemeine Paslode Sicherheitshinweise	S	Kontrollera att följande finns med: <ul style="list-style-type: none">▶ Spikpistol▶ Säkerhetsglasögon▶ Insexnyckel▶ Bruksanvisning▶ Paslodes Allmänna Säkerhetsbruksanvisning
F	votre carton doit contenir: <ul style="list-style-type: none">▶ un cloueur à bande▶ une paire de lunettes de sécurité▶ un jeu de clés allen▶ un manuel d'utilisation PSN90/PSN100▶ un manuel de consignes de sécurité	FIN	Tarkista pakkauksen sisältö: <ul style="list-style-type: none">▶ Vinolipasnaulain▶ Suojalasit▶ Kuusiokoloavaimet▶ PSN90/PSN100 käyttöohje▶ Yleinen Paslode turvallisuusohje
E	Revision de contenidos: <ul style="list-style-type: none">▶ Clavadora para clavos en peine▶ Gafas protectoras▶ LLaves Allen▶ Manual de funcionamiento de la PSN90/PSN100▶ Manual General de Seguridad Paslode	N	Kontroller innholdet: <ul style="list-style-type: none">▶ Spikerpistol▶ Beskyttelsesbriller▶ Smøreolje i flaske▶ Bruksanvisning
NL	Controleer de inhoud: <ul style="list-style-type: none">▶ Stripapparaat▶ Veiligheidsbril▶ Inbussleutels▶ Gebruikershandleiding PSN90/PSN100▶ Algemene veiligheidsvoorschriften Paslode	P	Inclui <ul style="list-style-type: none">▶ Máquina de prego bobine▶ Oculos de segurança▶ Chaves Allen▶ Manual de instruções da CNW 65.1▶ Manual Geral de Segurança da Paslode
DK	Check indholdet: <ul style="list-style-type: none">▶ Sømpistol▶ Sikkerheds briller▶ Hexagonal nøgle▶ PSN90/PSN100 Betjeningsvejledning▶ Generel Paslode sikkerhedsmanual	I	Controllare il contenuto: <ul style="list-style-type: none">▶ Chiodatrice a rullo▶ Occhiali antinfortunistici▶ Chiavi a brugola▶ Libretto di uso e manutenzione di CNW 65.1▶ Manuale di sicurezza generale Paslode

Daily maintenance:

D	Bitte überprüfen Sie täglich: <ol style="list-style-type: none">1. Leichtgängige Sicherheitsnase (WCE)2. Schalterbewegung3. Übermässig abgenutzter oder gebrochener Handgriff4. Alle Schrauben und Bolzen müssen fest sein	S	Dagligt underhåll: <ol style="list-style-type: none">1. Säkerhetsbygeln ska fungera mjukt vid manöver.2. Kontrollera avtryckaren.3. Handtaget får inte vara överdrivet nedslitet eller ha sprickor.4. Kontrollera att alla skruvar och bultar är ordentligt fastskruvade.
F	maintenance quotidienne: <ol style="list-style-type: none">1. s'assurer que le palpeur de sécurité coulisse librement2. vérifier que la gâchette soit libre3. vérifier que la poignée de l'appareil ne présente pas de fissures ou d'usure importante.4. vérifier que toutes les vis de l'appareil sont bien serrées	FIN	Päivittäinen tarkistus: <ol style="list-style-type: none">1. Tarkista varmistimen liikkuvuus2. Tarkista liipasimen liikkuvuus3. Tarkista rungon kunto4. Tarkista ruuvien ja pulttien kireys
E	Mantenimiento Diario: <ol style="list-style-type: none">1. Desplazamiento del Seguro2. Colocacion del Gatillo3. Empuñadura excesivamente desgastada o agrietada4. Ajuste de todos los tornillos y tuercas	N	Daglig vedlikehold: <ol style="list-style-type: none">1. Sikkerhetsbøylens bevegelse2. Avtrekkerbevegelse3. Ekstrem slitasje eller sprekker i pistolhuset4. Sitter alle skruer og bolter fast?
NL	Dagelijks onderhoud: <ol style="list-style-type: none">1. Soepele werking van de veiligheidsbeugel2. Trekker mechaniek3. Uitzonderlijk versleten of gescheurd handvat4. Alle schroeven en moeren zitten vast	P	Manutenção: <ol style="list-style-type: none">1. Movimento do sistema de segurança2. Movimento do gatilho3. Punho partido ou excessivamente gasto4. Todos os parafusos e porcas estão apertados
DK	Daglig vedligehold: <ol style="list-style-type: none">1. Check sikring går let og ubesværet2. Check aftrækker kan bevæges ubesværet3. Check for slidtage eller revner i materialet4. Alle skruer og bolte sidder fastspændt	I	Manutenzione quotidiana: <ol style="list-style-type: none">1. Scorrimento agevole del meccanismo2. Corretto movimento del grilletto3. Buono stato dell'impugnatura (non troppo usurata o rotta)4. Serraggio corretto di tutte le viti

Prepare for use



User settings

Depth control

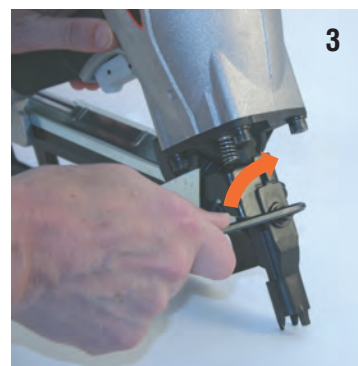
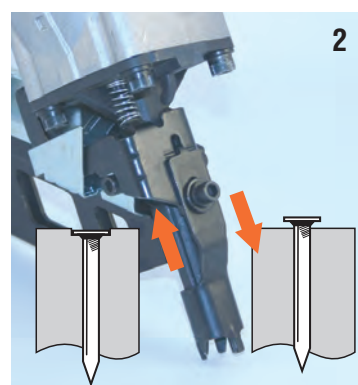
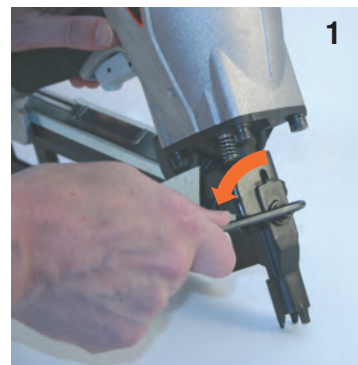

Prepare for use
User settings
Depth control

D

Vor dem Gebrauch
Grundeinstellungen vor nehmen
Tiefeneinstellung

F

mise en service
installation
réglage de profondeur

E

Preparacion para el uso
Ajuste de la maquina
Control de profundidad

NL

Vorbereiding ingebruikname
Gebruikersinstellingen
Diepteregeling

DK

Gør klar til brug
Operatør indstilling
Dybde regulering

S

Före användning
Ställ in verktyget för användning
Kontrollera djupinställningen

FIN

Ennen käyttöä
Käyttöasetukset
Syvyyden säätö

N

Klargjør for bruk
Brukerinnstillinger
Innskytingsdybde

P

Preparar para utilizar
Colocar em posição
Controlar a profundidade

I

Preparazione all'uso
Regolazioni dell'utilizzatore
Controllo di profondità

Clearing a jam

 Always disconnect from compressed air supply before servicing, adjusting the tool, or clearing a jam.

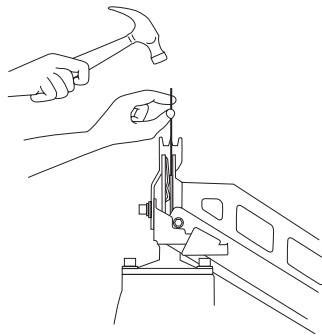

Take the tool out of service immediately and have it serviced by an authorised service engineer



Clearing a jam



Always disconnect from compressed air supply before servicing, adjusting the tool, or clearing a jam.



Take tool out of service immediately and have it serviced by an authorised service engineer.

D

Lösen eines verklemmten Nagels



Die Druckluftzufuhr vor Einstellung bzw. Reparatur des Geräts stets unterbrechen.



Gerät sofort aus dem Verkehr ziehen und nur von autorisiertem Fachpersonal überprüfen lassen.

F

Recherche des pannes



Débrancher l'outil de son alimentation en air comprimé avant toute opération de maintenance, de réglage ou de déblocage.



Ne travailler jamais avec un appareil défectueux. Si la panne persiste envoyer votre appareil au service après vente qualifié.

E

Desatascar la maquina



Desconecte siempre la herramienta del suministro de aire comprimido, antes de llevar a cabo operaciones de mantenimiento o ajuste, o de despejar un atasco.



Deje de utilizar la maquina inmediatamente y lleve a un servicio tecnico autorizado.

NL

Een storing oplossen



Koppel altijd de aan voer van perslucht los voordat u onderhoud gaat plegen, het apparaat afstelt of een storing wegneemt.



Het apparaat onmiddellijk uit gebruik nemen en laten repareren door een hiertoe gemachtigde service monteur.

DK

Hvordan fjerner man evt. Fastklemte befæstelseselementer



Afbryd altid tryklufften før justering eller reparation af sømpistolen.



Tag værktøjet ud af brug omgående og hav det serviceret af et autoriseret værksted

S

Rensa vid fastkörning



Avbryt alltid trycklufttillförseln innan du justerar eller utför reparationsarbete på spikningsverktygen.



Stäng av verktyget omedelbart och låt en auktoriserad serviceman åtgärda felet.

FIN

Jumiutuneiden naulojen poistaminen



Irrrota työkalu paineilmajärjestelmästä aina ennen huoltoa, työkalun säätöä tai tukoksen selvittämistä.



Poista naulain käytöstä välittömästi ja korjauta valtuutetussa huollossa.

N

Reparere en forkiling



Steng alltid av tryklufften før justering eller reparasjon av stiftepistolen.



Ta verktøyet ut av bruk omgående og lever det inn til service hos en godkjent service-mann

P

Desempenar a máquina



Desligue sempre a a máquina do compressor de ar antes de fazer a manutenção, ajustar a máquina ou desenravar um prego.



Retire a máquina de serviço imediatamente e ponha-a ao dispor de um engenheiro autorizado.

I

Eliminazione di un inceppamento



Prima di intervenire su di un attrezzo, ripararlo o eliminare un inceppamento, scollegare sempre la fonte di aria compressa.



Interrompere immediatamente l'utilizzo dell'attrezzo e farlo riparare presso un centro autorizzato

**GB****GB: DECLARATION OF CONFORMITY**

We declare that this product is in conformity with the following standards or other normative documents.

EN 292-1:1991; EN 292-2:1995; EN349:1993; EN 792-13:2000

Following the provision of EEC Directives

D**KONFORMITÄTSERKLÄRUNG**

Wir erklären, dass dieses Produkt mit den folgenden Normen oder normativen Dokumenten übereinstimmt.

EN 292-1:1991; EN 292-2:1995; EN349:1993; EN 792-13:2000

Gemäß den Bestimmungen der EWG

F**DÉCLARATION DE CONFORMITÉ**

Nous déclarons que ce produit est conforme aux normes ou autres documents normatifs.

EN 292-1:1991; EN 292-2:1995; EN349:1993; EN 792-13:2000

Conformément aux dispositions des Directives du EEC

E**DECLARACION DE CONFORMIDAD**

Nosotros declaramos que este producto está en conformidad con los siguientes estándares u otras normas de documentación.

EN 292-1:1991; EN 292-2:1995; EN349:1993; EN 792-13:2000

NL**KONFORMITEITS VERKLARING**

Wij verklaren dat dit produkt conform de volgende standaarden of andere norm stellingen is.

EN 292-1:1991; EN 292-2:1995; EN349:1993; EN 792-13:2000

DK**OVERENSTEMMELSESERKLAERING**

Erklærer herved, at produktet er i overensstemmelse med nedenstående normer eller normative dokumenter.

EN 292-1:1991; EN 292-2:1995; EN349:1993; EN 792-13:2000

I henhold til bestemmelserne i EU's direktiv

S**KONFORMITETSDEKLARATION**

Deklarerar att denna produkt är i konformitet med följande standard eller andra normativa dokument.

EN 292-1:1991; EN 292-2:1995; EN349:1993; EN 792-13:2000

I enlighet med föreskrifterna i EEC Direktiven

FIN**VAATIMUKSEN MUKAISUUSVAKUUTUS**

Vahvistaa, että tämä tuote Paineilmanalain on seuraavien vaatimusten tai normidokumenttien mukainen.

EN 292-1:1991; EN 292-2:1995; EN349:1993; EN 792-13:2000

N**SAMSVAR SERKÆRING**

Vi erklærer at dette produkt samsvarer med følgende standarder eller normer.

EN 292-1:1991; EN 292-2:1995; EN349:1993; EN 792-13:2000

Som følger bestemmelser i EU-direktiv

P**DECLARAÇÃO DE CONFORMIDADE**

Declaramos que este produto está em conformidade com as seguintes normas standard ou outros documentos normativos.

EN 292-1:1991; EN 292-2:1995; EN349:1993; EN 792-13:2000

Seguindo as directivas EEC

I**DICHIARZIONE DE CONFORMITA**

Noi dichiariamo che questo prodotto è conforme alle norme o ad altri documenti normativi.

EN 292-1:1991; EN 292-2:1995; EN349:1993; EN 792-13:2000

In conformita alle disposizioni delle Directive

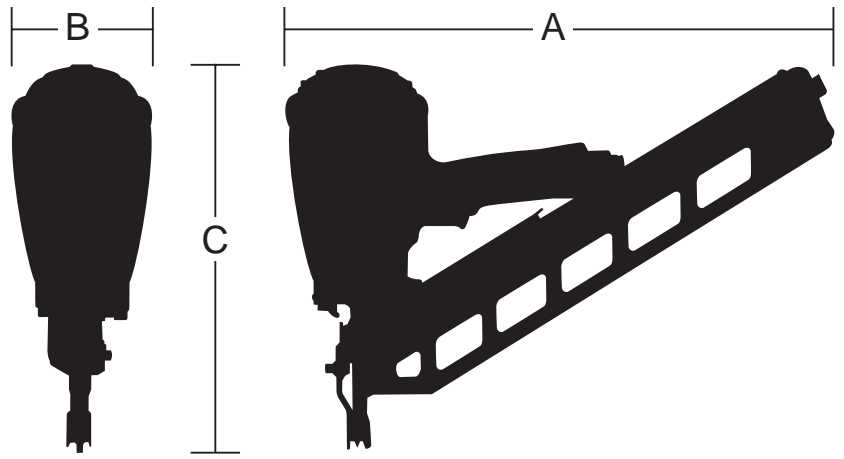

Technische Daten / Spécification Techniques / Technical Specifications

D	F	UK	Dim.	PSN90	PSN100
Spezifikat.Befestig.-mittel	Spécification des moyens de fixation	Fastener Specification	Ø	2.8 - 3.4mm	2.8 - 3.4mm
			L	50 - 90mm	50 - 100mm
Geräte gewicht	Poids	Tool Weight		3,6kg	3,9kg
Abmessung	Spécification	Dimensions	A	500mm	500mm
			B	130mm	130mm
			C	350mm	380mm
Luftverbrauch	Consommation d'air	Air consumption		2,4 litre	2,7 litre
Betriebsdruck	Pression d'opération	Operating Pressure	min. - max.	5 - 8 bar	5 - 8 bar
Lade kapazität	Capacité du magasin	Load Capacity	max.	90	90
Schallpegel	Valeurs du bruit	Noise Level	L WA, 1s	104dB	104dB
			L pA, 1s	96dB	96dB
			L pC peak		
Vibrations-werte	Valeurs de vibration	Vibration Value	a hwz	3,9m/s²	4,3m/s²

Normative Dokumente / Documents Normatifs / Normative Documents
 EN 12549: 1999/2, EN ISO 8662-11: 1999

Tools are suitable for use with PL collated strip nails according ITW Paslode specification.

ITW Paslode – van Heemskerckweg 5; 5928 RB Venlo; The Netherlands.

Erik Mul – Design

PSN90

501560

Strip Nailer

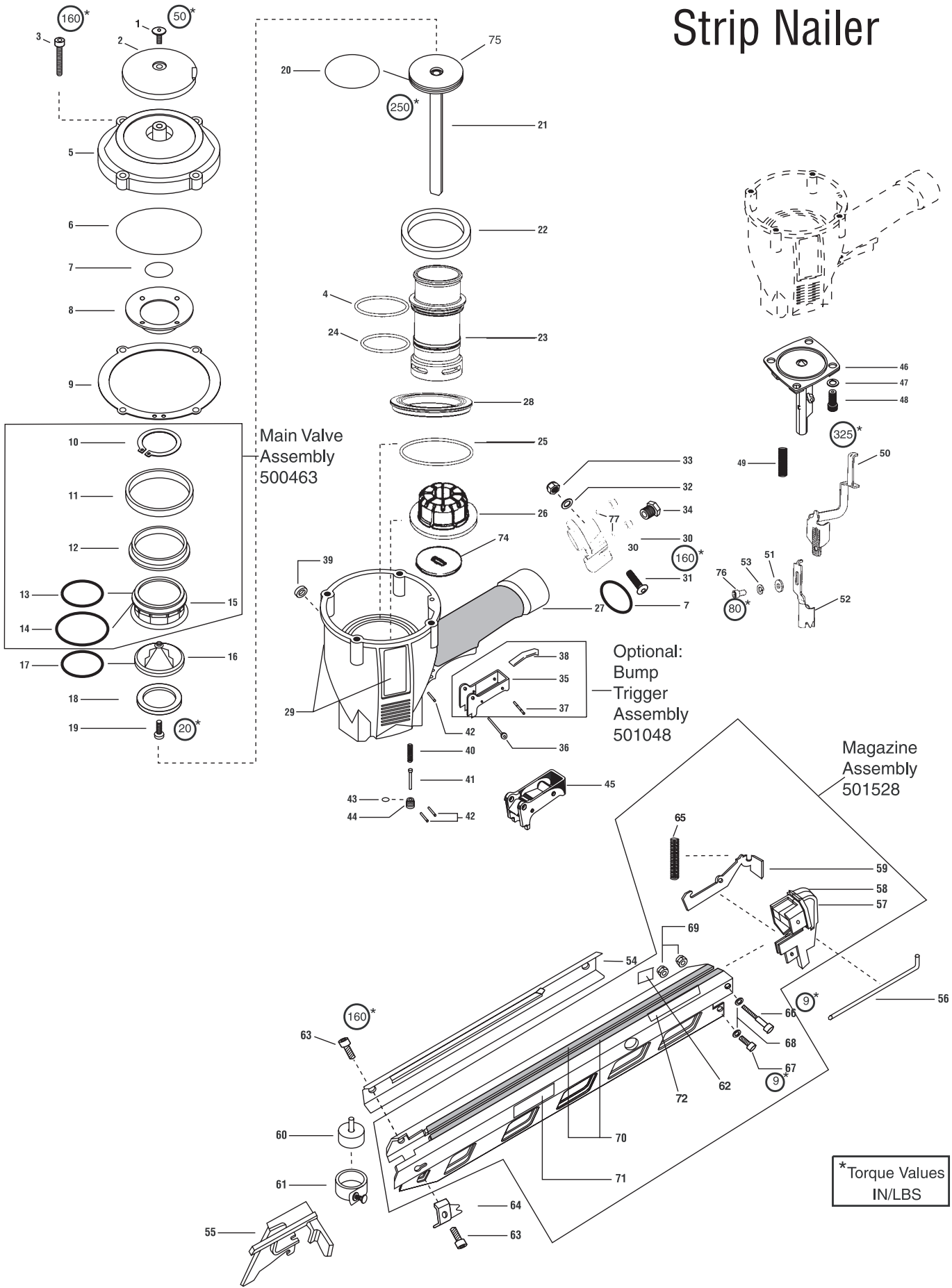

*Torque Values
IN/LBS

Ref. No.	Part No.	Qty	Description
1	501043	1	T.H.S.C.S. 1/4 -20 x 1/2"
2	501016	1	Air Deflector
3	501300	4	S.H.C.S. 1/4-20 x 1-1/4"
4	500249	1	O-Ring, Sleeve
5	501017	1	Cap
6	500461	1	O-Ring
7	092042	2	O-Ring
8	500407	1	Spring, Main Valve
9	501001	1	Gasket, Cap
10	406041	1	Retaining Ring
11	500455	1	Upper Valve Piston
12	401946	1	Seal, Main Valve
13	091208	1	O-Ring
14	401950	1	O-Ring
15	500456	1	Lower Valve Piston
16	500454	1	Post
17	095432	1	O-Ring
18	500453	1	Bumper, Post
19	402906	1	B.H.S.C.S.10-32 x 5/8"
20	092971	1	O-Ring, Piston
21	501218	1	Driver Blade
22	402011	1	Seal Sleeve
23	501283	1	Sleeve
24	092235	1	O-Ring, Sleeve
25	501002	1	O-Ring
26	500866	1	Bumper
27	501286	1	Housing
28	500779	1	Flange, Sleeve
29	501333	1	Label, Housing - Left
	501334	1	Label, Housing - Right
30	501219	1	End Cap, Housing
31	500516	1	B.H.S.C.S. - Special
32	404274	1	Flat Washer
33	500525	1	Locknut, 5/16-24
34	091622	1	Reducing Pipe Bushing
35	501010	1	Bump Trigger
36	402669	1	Pin, Trigger
37	501009	1	Spirol Pin
38	501008	1	Lever, Bottom Trip
39	402668	1	Retaining Ring
40	097748	1	Spring, Valve Pin
41	097746	1	Valve Pin
42	071297	3	Roll Pin 1/8 x 1-1/8"
43	092174	1	O-Ring, Valve Body
44	401958	1	Valve Body
45	501039	1	Sequential Trigger

Ref. No.	Part No.	Qty	Description
46	501052	1	Nose 30°
47	095417	4	Lockwasher 5/16
48	009016	4	S.H.C.S. 5/16-18 x 1"
49	501006	1	Spring, W.C.E.
50	501363	1	Upper W.C.E.
51	404800	1	Washer, W.C.E.
52	500731	1	Lower W.C.E.
53	002187	1	Lock Washer
54	500717	1	Nail Cover
55	500531	1	Follower
56	501044	1	3/16 Hex Key, Long Arm
57	501024	1	End Cap, Magazine-LF
58	501025	1	End Cap, Magazine-RT
59	501027	1	Latch
60	501046	1	Drum Pin Assembly
61	500513	1	Negator Assembly
62	501524	1	Nameplate
63	404904	2	Screw 1/4-28 x 5/8"
64	500509	1	Front Bracket
65	501028	1	Spring, Latch
66	501026	1	S.H.C.S. 8-32 x 2"
67	066840	1	S.H.C.S. 8-32 x 3/4"
68	404414	2	Flatwasher #8
69	404325	2	Stop Nut
70	500520	2	Wear Strip
71	500458	1	Warning Label
72	501055	1	Logo Label
74	500729	1	Blade Seal
75	501337	1	Piston
76	091618	1	S.H.C.S. 1/4-20 x 1/2"
77	501299	2	S.H.C.S. 1/4-20 x 1"

PSN100

500705

Strip Nailer

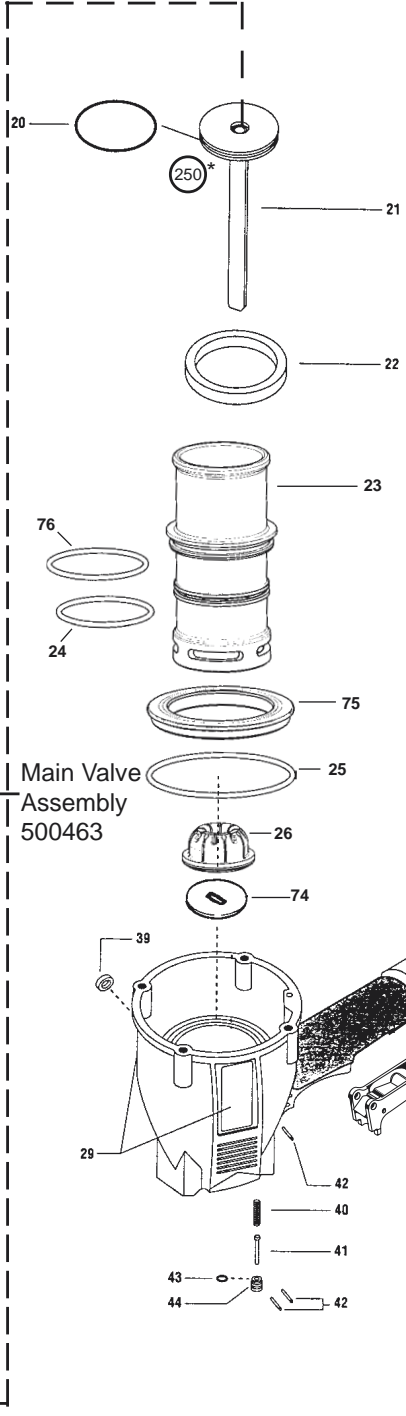
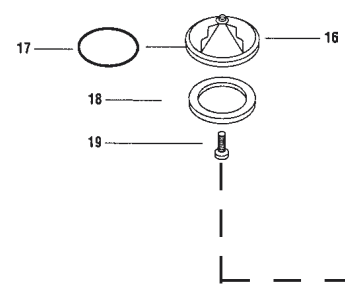
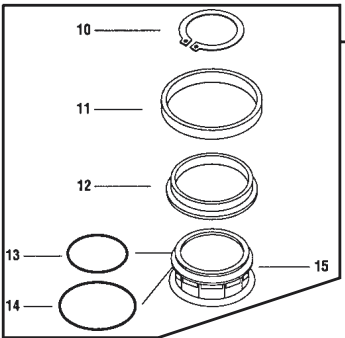
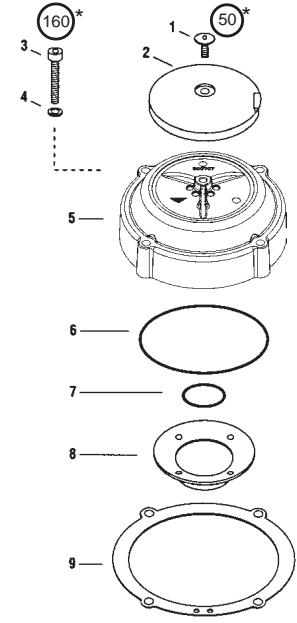

Main Valve Assembly
500463

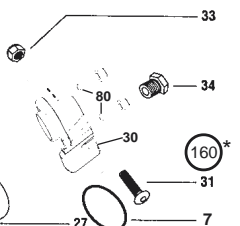
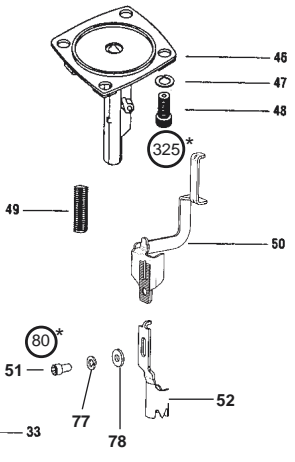
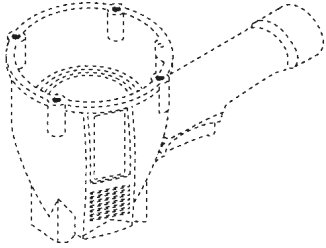

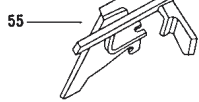
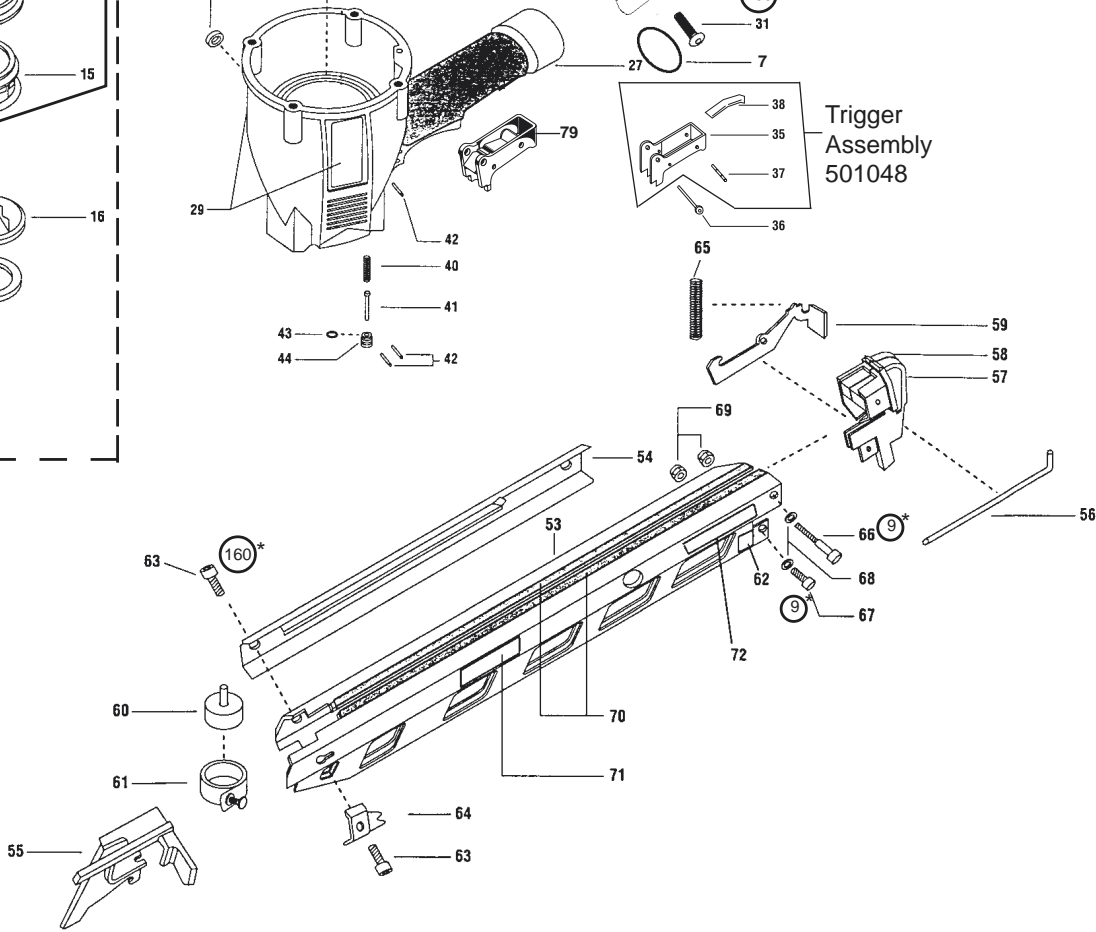

Trigger Assembly
501048



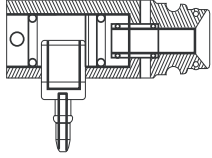
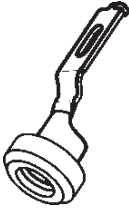

Ref. No.	Part No.	Qty	Description
1	501043	1	T.H.S.C.S. 1/4 -20 x 1/2"
2	501016	1	Air Deflector
3	091873	4	S.H.C.S. 1/4-20 x 2"
4	092757	4	Flatwasher 1/4"
5	500707	1	Cap
6	500461	1	O-Ring
7	092042	2	O-Ring
8	500407	1	Spring, Main Valve
9	501001	1	Gasket, Cap
10	406041	1	Retaining Ring
11	500455	1	Upper Valve Piston
12	401946	1	Seal, Main Valve
13	091208	1	O-Ring
14	401950	1	O-Ring
15	500456	1	Lower Valve Piston
16	500454	1	Post
17	095432	1	O-Ring
18	500453	1	Bumper, Post
19	402906	1	B.H.S.C.S.10-32 x 5/8"
20	092971	1	O-Ring, Piston
21	500709	1	Piston Assembly
22	402011	1	Seal Sleeve
23	500710	1	Sleeve
24	092235	1	O-Ring, Sleeve
25	501002	1	O-Ring
26	500866	1	Bumper
27	501286	1	Housing
29	501333	1	Label, Housing-Leftside
	501334	1	Label, Housing-Rightside
30	501219	1	End Cap, Housing
31	500516	1	B.H.S.C.S. - Special
32	404274	1	Flatwasher
33	500525	1	Locknut, 5/16-24
34	091622	1	Reducing Pipe Bushing
35	501010	1	Trigger
36	402669	1	Pin, Trigger
37	501009	1	Spirol Pin
38	501008	1	Lever, Bottom Trip
39	402668	1	Retaining Ring
40	097748	1	Spring, Valve Pin
41	097746	1	Valve Pin
42	071297	3	Roll Pin 1/8 x 1-1/8"
43	092174	1	O-Ring, Valve Body
44	401958	1	Valve Body
46	500712	1	Nose 30°
47	095417	4	Lockwasher 5/16

Ref. No.	Part No.	Qty	Description
48	009016	4	S.H.C.S. 5/16-18 x 1"
49	501006	1	Spring, W.C.E.
50	501363	1	Upper W.C.E.
51	091618	1	S.H.C.S. 1/4-20 x 1/2"
52	500713	1	Lower W.C.E.
53	501491	1	Magazine with Wear Strips
54	500717	1	Nail Cover
55	500531	1	Follower
56	501044	1	3/16 Hex Key, Long Arm
57	501024	1	End Cap, Magazine-LF
58	501025	1	End Cap, Magazine-RT
59	501027	1	Latch
60	501046	1	Drum Pin Assembly
61	500513	1	Negator Assembly
62	500839	1	Nameplate
63	404904	2	Screw 1/4-28 x 5/8"
64	500509	1	Front Bracket
65	501028	1	Spring, Latch
66	501026	1	S.H.C.S. 8-32 x 2"
67	066840	1	S.H.C.S. 8-32 x 3/4"
68	404414	2	Flatwasher #8
69	404325	2	Stop Nut
70	500520	2	Wear Strip
71	500458	1	Warning Label
72	500838	2	Logo Label
74	500729	1	Blade Seal
75	500779	1	Flange, Sleeve
76	500249	1	O-Ring, Sleeve
77	002187	1	Lock Washer
78	404800	1	Flat Washer
79	501039	1	Sequential Trigger
80	501299	2	S.H.C.S. 1/4-20 x 1"

Accessories

		PSN90	PSN100
	Remote Fire Valve This valve via a positive air signal allows a machine mounted tool to be operated from an automatic air valve or foot pedal system.	1X0713	1X0713
	Trigger Valve Kit Repairs trigger valve air leaks	219224	219224
	No-Mar Work Contacting Element W.C.E. with a rubber tip prevents you from marring wood surfaces	219228	500903
	No-Mar Tip Replacement tip for No-Mar Work Contacting Element	501022	501022
	Lubricants and Loctite Loctite 242 (Blue) 093500 093500 Lubricating Oil 16 oz 403720 403720 Lubricating Oil with Antifreeze 219090 219090 Chemplex 710 Lubricant 1 lb 403734 403734 Lubricant 5 gram tube 219188 219188		
	Degreaser Cleaner Ideal cleaner for all Paslode tools	219086	219086
	Safety Glasses Clear 402510 402510 Tinted 402512 402512		

- GB** For safe operation of Paslode pneumatic tools, use only those fasteners identified in the operating manual.
- D** Für sicheres Arbeiten der pneumatischen Paslode Geräte bitte nur in der Gebrauchsanleitung spezifizierte Verbindungsmittel benutzen.
- F** Pour une utilisation en toute sécurité de vos cloueurs pneumatiques Paslode, utilisez uniquement les consommables spécifiés dans le manuel opératoire
- E** Por razones de seguridad, con las máquinas neumáticas Paslode utilice sólo los “fasteners” especificados en el manual de instrucciones de la máquina.
- NL** Voor een veilige werking van Paslode pneumatisch apparaat; gebruik ten allen tijde alleen de voorgeschreven (zie gebruiksvorschriften) verbruiksmaterialen.
- DK** Tænk på dine kollegers og din egen sikkerhed! Anvend kun de af producenten specificerede søm til denne pistol.
- S** För säker användning av Paslode lufttryckverktyg, använd endast i användarmanualen angivna fästelement.
- FIN** Paslode paineilmanaulaimien turvallisen toimivuuden varmistamiseksi, käytäkää vain tässä käyttöohjeessa eriteltyjä nauvoja.
- N** For sikker bruk av Paslode trykkluftverktøy, må det kun brukes spiker som er angitt i instruksjonsheftet.
- P** Por questões de segurança das máquinas pneumáticas Paslode, use apenas os produtos identificados no manual de procedimentos
- I** Per utilizzare in sicurezza le chiodatrici pneumatiche Paslode, usare solo i chiodi prescritti nel libretto di uso e manutenzione.

+

=

EN792-13
European
Safety
Standard

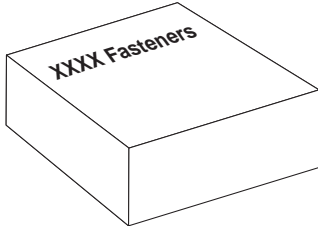
For safe operation of Paslode pneumatic tools, use only those fasteners identified in the operating manual.

+

=

EN792-13
European
Safety
Standard