

Operating Instructions

VEGAWAVE 61

- contactless electronic switch



Document ID:
32246



Vibration

Contents

1	About this document	
1.1	Function	4
1.2	Target group	4
1.3	Symbolism used	4
2	For your safety	
2.1	Authorised personnel	5
2.2	Appropriate use	5
2.3	Warning about misuse	5
2.4	General safety instructions	5
2.5	Safety label on the instrument	6
2.6	CE conformity	6
2.7	SIL conformity	6
2.8	Safety instructions for Ex areas	6
2.9	Environmental instructions	6
3	Product description	
3.1	Structure	7
3.2	Principle of operation	8
3.3	Operation	8
3.4	Storage and transport	9
4	Mounting	
4.1	General instructions	10
4.2	Instructions for installation	11
5	Connecting to power supply	
5.1	Preparing the connection	15
5.2	Connection procedure	15
5.3	Wiring plan, single chamber housing	16
6	Set up	
6.1	General information	19
6.2	Adjustment elements	19
6.3	Function chart	20
7	Maintenance and fault rectification	
7.1	Maintenance	22
7.2	Remove interferences	22
7.3	Exchanging the electronics module	23
7.4	Instrument repair	24
8	Dismounting	
8.1	Dismounting steps	25
8.2	Disposal	25
9	Supplement	
9.1	Technical data	26

9.2	Dimensions	29
-----	----------------------	----

Supplementary documentation



Information:

Supplementary documents appropriate to the ordered version come with the delivery. You can find them listed in chapter "*Product description*".

Instructions manuals for accessories and replacement parts



Tip:

To ensure reliable setup and operation of your VEGAWAVE 61, we offer accessories and replacement parts. The corresponding documentations are:

- 32357 - External housing - VEGAWAVE
- 32356 - Electronics module VEGAWAVE series 60
- 34296 - Protective cover

Editing status: 2012-04-12

1 About this document

1.1 Function

This operating instructions manual provides all the information you need for mounting, connection and setup as well as important instructions for maintenance and fault rectification. Please read this information before putting the instrument into operation and keep this manual accessible in the immediate vicinity of the device.

1.2 Target group

This operating instructions manual is directed to trained qualified personnel. The contents of this manual should be made available to these personnel and put into practice by them.

1.3 Symbolism used



Information, tip, note

This symbol indicates helpful additional information.



Caution: If this warning is ignored, faults or malfunctions can result.

Warning: If this warning is ignored, injury to persons and/or serious damage to the instrument can result.

Danger: If this warning is ignored, serious injury to persons and/or destruction of the instrument can result.



Ex applications

This symbol indicates special instructions for Ex applications.



List

The dot set in front indicates a list with no implied sequence.



Action

This arrow indicates a single action.



Sequence

Numbers set in front indicate successive steps in a procedure.

2 For your safety

2.1 Authorised personnel

All operations described in this operating instructions manual must be carried out only by trained specialist personnel authorised by the plant operator.

During work on and with the device the required personal protective equipment must always be worn.

2.2 Appropriate use

The VEGAWAVE 61 is a sensor for level detection.

You can find detailed information on the application range in chapter "*Product description*".

Operational reliability is ensured only if the instrument is properly used according to the specifications in the operating instructions manual as well as possible supplementary instructions.

For safety and warranty reasons, any invasive work on the device beyond that described in the operating instructions manual may be carried out only by personnel authorised by the manufacturer. Arbitrary conversions or modifications are explicitly forbidden.

2.3 Warning about misuse

Inappropriate or incorrect use of the instrument can give rise to application-specific hazards, e.g. vessel overfill or damage to system components through incorrect mounting or adjustment.

2.4 General safety instructions

This is a high-tech instrument requiring the strict observance of standard regulations and guidelines. The user must take note of the safety instructions in this operating instructions manual, the country-specific installation standards as well as all prevailing safety regulations and accident prevention rules.

The instrument must only be operated in a technically flawless and reliable condition. The operator is responsible for trouble-free operation of the instrument.

During the entire duration of use, the user is obliged to determine the compliance of the necessary occupational safety measures with the current valid rules and regulations and also take note of new regulations.

2.5 Safety label on the instrument

The safety approval markings and safety tips on the device must be observed.

2.6 CE conformity

This device fulfills the legal requirements of the applicable EC guidelines. By attaching the CE mark, VEGA provides a confirmation of successful testing. You can find the CE conformity declaration in the download area of "www.vega.com".

2.7 SIL conformity

VEGAWAVE 61 meets the requirements to the functional safety according to IEC 61508. Further information is available in the Safety Manual "*VEGAWAVE series 60*".

2.8 Safety instructions for Ex areas

Please note the Ex-specific safety information for installation and operation in Ex areas. These safety instructions are part of the operating instructions manual and come with the Ex-approved instruments.

2.9 Environmental instructions

Protection of the environment is one of our most important duties. That is why we have introduced an environment management system with the goal of continuously improving company environmental protection. The environment management system is certified according to DIN EN ISO 14001.

Please help us fulfil this obligation by observing the environmental instructions in this manual:

- Chapter "*Packaging, transport and storage*"
- Chapter "*Disposal*"

3 Product description

3.1 Structure

Scope of delivery

The scope of delivery encompasses:

- VEGAWAVE 61 point level switch
- Documentation
 - this operating instructions manual
 - Safety Manual "*Functional safety (SIL)*" (optional)
 - Supplementary instructions manual "*Plug connector for level sensors*" (optional)
 - Ex-specific "*Safety instructions*" (with Ex versions)
 - if necessary, further certificates

Constituent parts

The VEGAWAVE 61 consists of the components:

- Housing cover
- Housing with electronics
- Process fitting with tuning fork

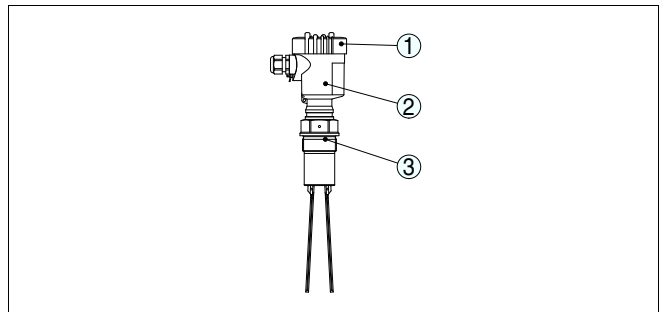

Fig. 1: VEGAWAVE 61 - with plastic housing

- 1 Housing cover
- 2 Housing with electronics
- 3 Process fitting

Type label

The type label contains the most important data for identification and use of the instrument:

- Article number
- Serial number
- Technical data
- Article numbers, documentation
- SIL identification (with SIL rating ex works)

With the serial number, you can access the delivery data of the instrument via www.vega.com, "VEGA Tools" and "*serial number search*". In addition to the type label outside, you can also find the serial number on the inside of the instrument.

3.2 Principle of operation

Application area

VEGAWAVE 61 is a point level sensor with tuning fork for level detection.

It is designed for industrial use in all areas of process technology and is preferably used for bulk solids.

Typical applications are overflow and dry run protection. Thanks to its simple and robust measuring system, VEGAWAVE 61 is virtually unaffected by the chemical and physical properties of the bulk solid.

It also works when subjected to strong external vibrations or changing products.

Solid detection in water

If VEGAWAVE 61 was ordered for solids detection in water, the tuning fork is set to the density of water. In air or when immersed in water (density: 1 g/cm³/0.036 lbs/in³), VEGAWAVE 61 signals "uncovered". Only when the vibrating element is also covered with solids (e.g. sand, sludge, gravel etc.) will the sensor signal "covered".

Fault monitoring

The electronics module of VEGAWAVE 61 monitors continuously the following criteria:

- Correct vibrating frequency
- Line break to the piezo drive

If one of the stated malfunctions is detected or in case of power failure, the electronics takes on a defined switching condition, i.e. the contactless electronic switch opens (safe condition).

Functional principle

The tuning fork is piezoelectrically energised and vibrates at its mechanical resonance frequency of approx. 150 Hz. When the tuning fork is submerged in the product, the vibration amplitude changes. This change is detected by the integrated electronics module and converted into a switching command.

Voltage supply

VEGAWAVE 61 is a compact instrument, i.e. it can be operated without external evaluation system. The integrated electronics evaluates the level signal and outputs a switching signal. With this switching signal, a connected device can be operated directly (e.g. a warning system, a pump etc.).

The data for power supply are specified in chapter "*Technical data*".

3.3 Operation

With the factory setting, products with a density of > 0.02 g/cm³ (0.0008 lbs/in³) can be measured. The instrument can also be adapted to products with lower density > 0.008 g/cm³ (0.0003 lbs/in³).

On the electronics module you will find the following indicating and adjustment elements:

- Signal lamp for indication of the switching condition (green/red)
- Potentiometer for adaptation to the product density
- Mode switch for selecting the switching condition (min./max.)

3.4 Storage and transport

Packaging	<p>Your instrument was protected by packaging during transport. Its capacity to handle normal loads during transport is assured by a test according to DIN EN 24180.</p> <p>The packaging of standard instruments consists of environment-friendly, recyclable cardboard. In addition, the sensor is provided with a protective cover of cardboard. For special versions PE foam or PE foil is also used. Dispose of the packaging material via specialised recycling companies.</p>
Transport	<p>Transport must be carried out under consideration of the notes on the transport packaging. Nonobservance of these instructions can cause damage to the device.</p>
Transport inspection	<p>The delivery must be checked for completeness and possible transit damage immediately at receipt. Ascertained transit damage or concealed defects must be appropriately dealt with.</p>
Storage	<p>Up to the time of installation, the packages must be left closed and stored according to the orientation and storage markings on the outside.</p> <p>Unless otherwise indicated, the packages must be stored only under the following conditions:</p> <ul style="list-style-type: none">● Not in the open● Dry and dust free● Not exposed to corrosive media● Protected against solar radiation● Avoiding mechanical shock and vibration
Storage and transport temperature	<ul style="list-style-type: none">● Storage and transport temperature see chapter "<i>Supplement - Technical data - Ambient conditions</i>"● Relative humidity 20 ... 85 %

4 Mounting

4.1 General instructions

Suitability for the process conditions

Make sure that all parts of the instrument exposed to the process, in particular the sensor element, process seal and process fitting, are suitable for the existing process conditions. These include above all the process pressure, process temperature as well as the chemical properties of the medium.

You can find the specifications in chapter "*Technical data*" and on the type label.

Switching point

In general, VEGAWAVE 61 can be installed in any position. The instrument only has to be mounted in such a way that the vibrating element is at the height of the desired switching point.

Moisture

Use the recommended cables (see chapter "*Connecting to power supply*") and tighten the cable gland.

You can give your instrument additional protection against moisture penetration by leading the connection cable downward in front of the cable entry. Rain and condensation water can thus drain off. This applies mainly to outdoor mounting as well as installation in areas where high humidity is expected (e.g. through cleaning processes) or on cooled or heated vessels.

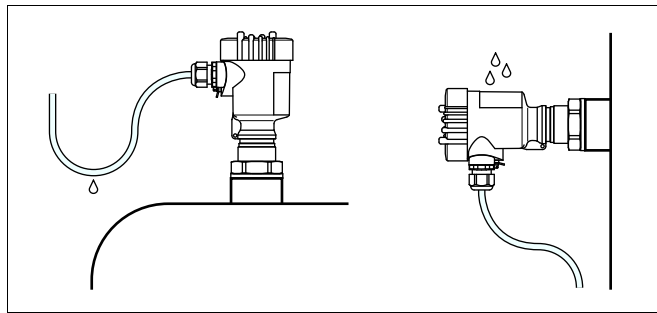

Fig. 2: Measures against moisture penetration

Transport

Do not hold VEGAWAVE 61 on the vibrating element. Especially with flange and tube versions, the sensor can be damaged by the weight of the instrument.

Remove the protective cover just before mounting.

Pressure/Vacuum

The process fitting must be sealed if there is gauge or low pressure in the vessel. Before use, check if the seal material is resistant against the measured product and the process temperature.

The max. permissible pressure is specified in chapter "Technical data" or on the type label of the sensor.

Handling

The vibrating level switch is a measuring instrument and must be treated accordingly. Bending the vibrating element will destroy the instrument.



Warning:

The housing must not be used to screw the instrument in! Applying tightening force can damage internal parts of the housing.

Use the hexagon above the thread for screwing in.

4.2 Instructions for installation

Socket

The vibrating element should protrude into the vessel to avoid buildup. For that reason, avoid using mounting bosses for flanges and screwed fittings. This applies particularly to use with adhesive products.

Filling opening

Mount the instrument in such a way that the tuning fork does not protrude directly into the filling stream.

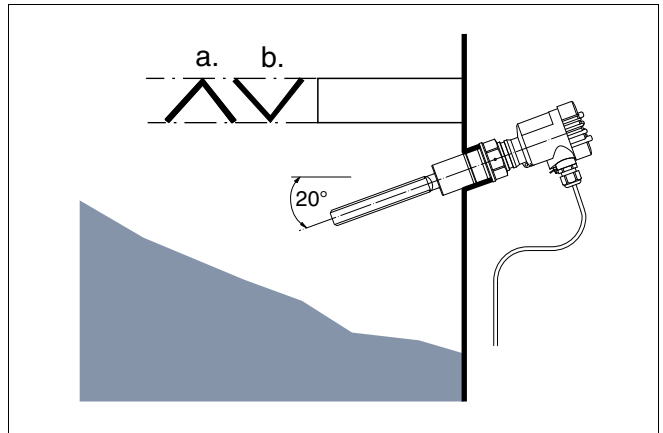

Fig. 3: Horizontal installation

- a Protective sheet
- b Concave protective sheet for abrasive solids

If such an installation location should be necessary, mount a suitable protective sheet above or in front of the vibrating element, see illustration "a").

In abrasive solids, mounting according to illustration "b" has proven. A spout forms in the concave protective sheet preventing wear of the protective sheet.

Horizontal installation

To achieve a very precise switching point, you can install VEGAWAVE 61 horizontally. However, if the switching point can have a tolerance of a few centimeters, we recommend mounting VEGAWAVE 61 approx. 20° inclined to the vessel bottom to avoid buildup.

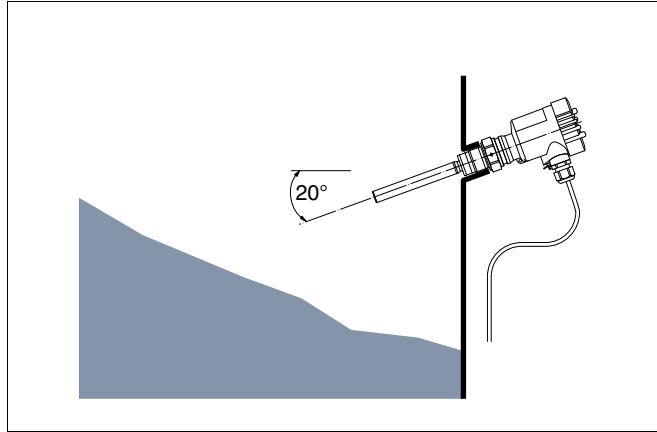

Fig. 4: Horizontal installation

Inflowing medium

If VEGAWAVE 61 is mounted in the filling stream, unwanted false measurement signals can be generated. For this reason, mount VEGAWAVE 61 at a position in the vessel where no disturbances, e.g. from filling openings, agitators, etc., can occur.

Flows

To minimise flow resistance caused by the tuning fork, VEGAWAVE 61 should be mounted in such a way that the surfaces of the blades are parallel to the product movement.

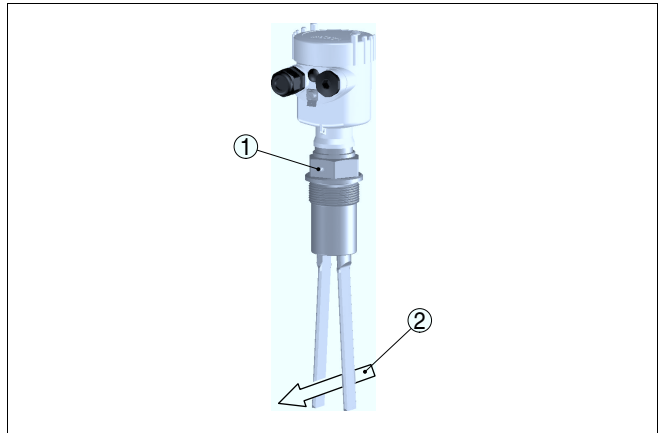

Fig. 5: Flow orientation of the tuning fork

- 1 Marking with screwed version
- 2 Direction of flow

Adhesive products

In case of horizontal mounting in adhesive products, the surfaces of the tuning fork should be vertical in order to reduce buildup on the tuning fork. On the screwed version you will find a marking on the hexagon. With this, you can check the position of the tuning fork when screwing it in. When the hexagon touches the seal, the thread can still be turned by approx. half a turn. This is sufficient to reach the recommended installation position.

With flange versions, the fork is directed to the flange holes.

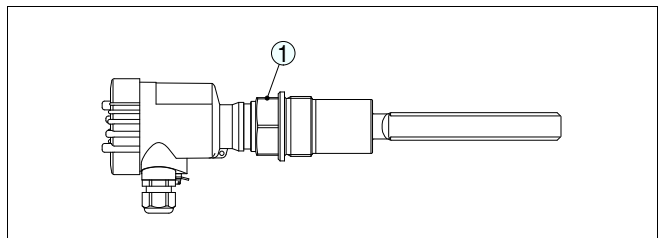

Fig. 6: Horizontal installation - marking

- 1 Marking on top with screwed version

Baffle protection against falling rocks

In applications such as grit chambers or settling basins for coarse sediments, the vibrating element must be protected against damage with a suitable baffle.

This baffle must be manufactured by you.

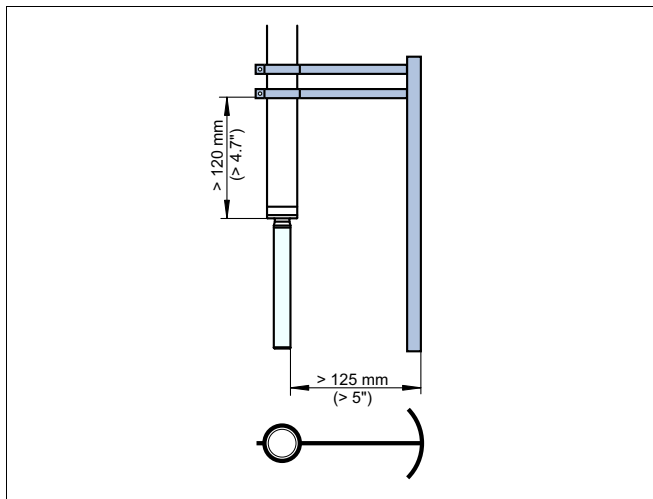

Fig. 7: Baffle for protection against mechanical damage

5 Connecting to power supply

5.1 Preparing the connection

Note safety instructions

Always keep in mind the following safety instructions:

- Connect only in the complete absence of line voltage

Take note of the safety instructions for Ex applications Voltage supply



In hazardous areas you must take note of the respective regulations, conformity and type approval certificates of the sensors and power supply units.

Connect the operating voltage according to the connection diagrams. The electronics module with contactless electronic switch is designed in protection class I. To maintain this protection class, it is absolutely necessary that the earth conductor is connected to the inner earth conductor terminal. Keep the general installation regulations in mind. Take note of the corresponding installation regulations for hazardous areas with Ex applications.

The data for power supply are specified in chapter "*Technical data*".

Connection cable

The instrument is connected with standard three-wire cable without screen. If electromagnetic interference is expected which is above the test values of EN 61326 for industrial areas, screened cable should be used.

Use cable with round cross-section. A cable outer diameter of 5 ... 9 mm (0.2 ... 0.35 in) ensures the seal effect of the cable gland. If you are using cable with a different diameter or cross-section, exchange the seal or use a suitable cable gland.



In hazardous areas, only use approved cable connections for VEGAWAVE 61.

Connection cable for Ex applications



Take note of the corresponding installation regulations for Ex applications.

Cover all housing openings conforming to standard according to EN 60079-1.

5.2 Connection procedure



With Ex instruments, the housing cover may only be opened if there is no explosive atmosphere present.

Proceed as follows:

- 1 Unscrew the housing cover
- 2 Loosen compression nut of the cable entry
- 3 Remove approx. 10 cm (4 in) of the cable mantle, strip approx. 1 cm (0.4 in) of insulation from the ends of the individual wires
- 4 Insert the cable into the sensor through the cable entry

- 5 Lift the opening levers of the terminals with a screwdriver (see following illustration)

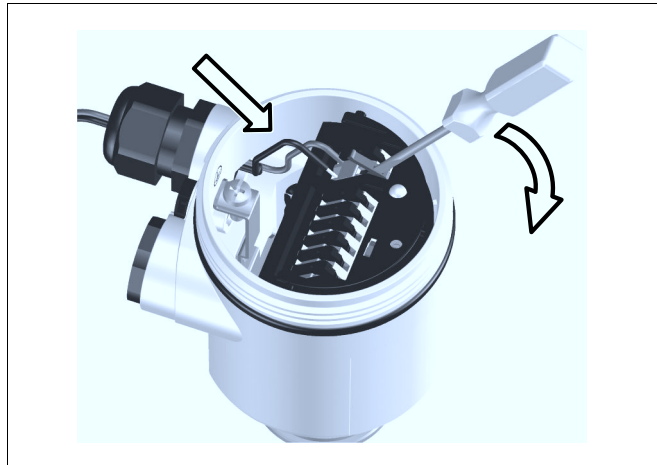

Fig. 8: Connection steps 5 and 6

- 6 Insert the wire ends into the open terminals according to the wiring plan
 - 7 Press down the opening levers of the terminals, you will hear the terminal spring closing
 - 8 Check the hold of the wires in the terminals by lightly pulling on them
 - 9 Tighten the compression nut of the cable entry. The seal ring must completely encircle the cable
 - 10 If necessary, carry out a fresh adjustment
 - 11 Screw the housing cover back on
- The electrical connection is finished.

5.3 Wiring plan, single chamber housing



The following illustrations apply to the non-Ex as well as to the EEx-d version.

Housing overview

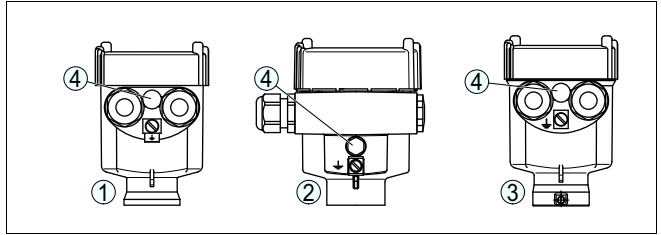

Fig. 9: Material versions, single chamber housing

- 1 Plastic (not with EEx d)
- 2 Aluminium
- 3 Stainless steel (not with EEx d)
- 4 Filter element for pressure compensation (not with EEx d)

Wiring plan

We recommend connecting VEGAWAVE 61 in such a way that the switching circuit is open when there is a level signal, line break or failure (safe condition).

The contactless electronic switch is always shown in non-operative condition.



Warning:

The instrument must not be operated without an intermediately connected load, because the electronics would be destroyed if connected directly to the mains. It is not suitable for connection to low voltage PLC inputs.

Examples for typical applications:

- Load resistance at 24 V DC: 88 ... 1800 Ω
- Rated power, relay 253 V AC: > 2.5 VA
- Rated power, relay 24 V AC: > 0.5 VA

For direct control of relays, contactors, magnet valves, warning lights, horns etc.

Domestic current is temporarily lowered below 1 mA after switching off the load so that contactors, whose holding current is lower than the constant domestic current of the electronics, are reliably switched off.

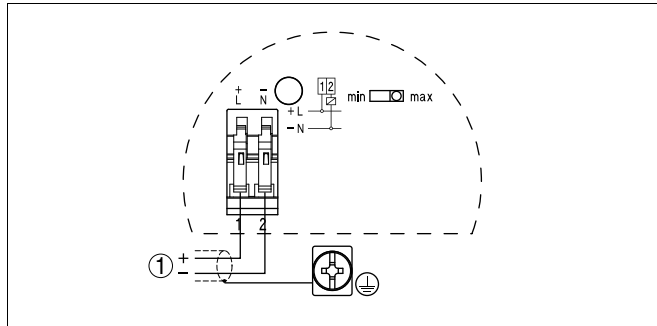

Fig. 10: Wiring plan

1 Shielding

6 Set up

6.1 General information

The figures in brackets refer to the following illustrations.

Function/Configuration

On the electronics module you will find the following indicating and adjustment elements:

- Potentiometer for adaptation to the product density (1)
- DIL switch for mode adjustment - min./max. (2)
- Signal lamp (5)



Note:

As a rule, always set the mode with mode switch (2) before starting the setup of VEGAWAVE 61. The switching output will change if you set the mode switch (2) afterwards. This could possibly trigger other connected instruments or devices.

6.2 Adjustment elements

Electronics and connection compartment

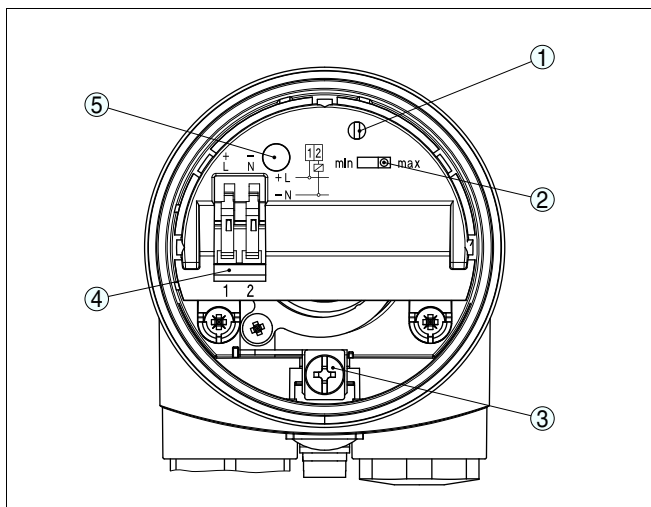

Fig. 11: Electronics and connection compartment - contactless electronic switch

- 1 Potentiometer for switching point adaptation
- 2 DIL switch for mode adjustment
- 3 Ground terminal
- 4 Connection terminals
- 5 Control lamp

Switching point adaptation (1)

With the potentiometer you can adapt the switching point to the solid. It is already preset and must only be modified in special cases.

By default, the potentiometer of VEGAWAVE 61 is set to the right stop (> 0.02 g/cm³ or 0.0008 lbs/in³). In case of very light-weight solids, turn the potentiometer to the left stop (> 0.008 g/cm³ or 0.0003 lbs/in³). VEGAWAVE 61 will thus be more sensitive and can detect light-weight solids more reliably.

For instruments detecting solids in water, these settings are not applicable. The switching point adaptation is preset and must not be changed.

Mode adjustment (2)

With the mode adjustment (min./max.) you can change the switching condition of the output. You can set the required mode according to the "Function chart" (max. - max. detection or overflow protection, min. - min. detection or dry run protection).

We recommend connecting according to the quiescent current principle (contactless electronic switch is open when the switching point is reached) because the contactless electronic switch takes on the same (safe) condition if a failure is detected.













Signal lamp (5)





Control lamp for indication of the switching status

- green = switch closed
- red = switch open
- red (flashing) = failure

6.3 Function chart

The following chart provides an overview of the switching conditions depending on the adjusted mode and level.

	Level	Switching status	Control lamp
Mode max. Overflow protection		 Switch closed	 Green
Mode max. Overflow protection		 Switch open	 Red
Mode min. Dry run protection		 Switch closed	 Green
Mode min. Dry run protection		 Switch open	 Red

	Level	Switching status	Control lamp
Failure of the supply voltage (min./max. mode)	any	 <p>Switch open</p>	
Malfunction	any	 <p>Switch open</p>	 <p>flashes red</p>

7 Maintenance and fault rectification

7.1 Maintenance

If the instrument is used properly, no special maintenance is required in normal operation.

7.2 Remove interferences

Reaction when malfunctions occur

The operator of the system is responsible for taking suitable measures to rectify faults.

Failure reasons

VEGAWAVE 61 offers maximum reliability. Nevertheless, faults can occur during operation. These may be caused by the following, e.g.:

- Sensor
- Process
- Voltage supply
- Signal processing

Fault rectification

The first measure to be taken is to check the output signal. In many cases, the causes can be determined this way and the faults rectified.

24 hour service hotline

Should these measures not be successful, please call in urgent cases the VEGA service hotline under the phone no. **+49 1805 858550**.

The hotline is available to you 7 days a week round-the-clock. Since we offer this service world-wide, the support is only available in the English language. The service is free of charge, only the standard telephone costs will be charged.

Checking the switching signal

Error	Cause	Rectification
VEGAWAVE 61 signals "covered" without being submerged (overflow protection) VEGAWAVE 61 signals "uncovered" when being submerged (dry run protection)	Operating voltage too low	Check operating voltage
	Electronics defective	Press the mode switch. If the instrument then changes the mode, the vibrating element may be covered with buildup or mechanically damaged. Should the switching function in the correct mode still be faulty, return the instrument for repair.
		Press the mode switch. If the instrument then does not change the mode, the electronics module may be defective. Exchange the electronics module.
	Unfavourable installation location	Mount the instrument at a location in the vessel where no dead zones or mounds can form.
Buildup on the vibrating element	Check the vibrating element and the sensor if there is buildup and remove it.	

Error	Cause	Rectification
	Wrong mode selected	Set the correct mode on the mode switch (overflow protection, dry run protection). Wiring should be carried out according to the quiescent current principle.
Signal lamp flashes red	Error on the vibrating element	Check if the vibrating element is damage or extremely corroded.
	Interference on the electronics module	Exchanging the electronics module
	instrument defective	Exchange the instrument or send it in for repair

Reaction after fault rectification

Depending on the reason for the fault and the measures taken, the steps described in chapter "Set up" may have to be carried out again.

7.3 Exchanging the electronics module

In general, all electronics modules of series WE60 can be interchanged. If you want to use an electronics module with a different signal output, you can download the corresponding operating instructions manual from our homepage under Downloads.



With EEx d instruments, the housing cover may only be opened if there is no explosive atmosphere present.

Proceed as follows:

- 1 Switch off power supply
- 2 Unscrew the housing cover
- 3 Lift the opening levers of the terminals with a screwdriver
- 4 Pull the connection cables out of the terminals
- 5 Loosen the two screws with a screw driver (Torx size T10 or slot 4)

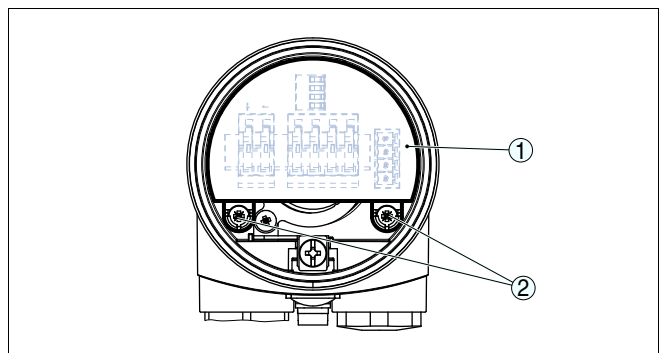

Fig. 28: Loosening the holding screws

- 1 Electronics module
- 2 Screws (2 pcs.)

- 6 Pull out the old electronics module
- 7 Compare the new electronics module with the old one. The type label of the electronics module must correspond to that of the old electronics module. This applies particularly to instruments used in hazardous areas.
- 8 Compare the settings of the two electronics modules. Set the adjustment elements of the new electronics module to the same setting of the old one.



Information:

Make sure that the housing is not rotated during the electronics exchange. Otherwise the plug may be in a different position later.

- 9 Insert the electronics module carefully. Make sure that the plug is in the correct position.
 - 10 Screw in and tighten the two holding screws with a screwdriver (Torx size T10 or Phillips 4)
 - 11 Insert the wire ends into the open terminals according to the wiring plan
 - 12 Press down the opening levers of the terminals, you will hear the terminal spring closing
 - 13 Check the hold of the wires in the terminals by lightly pulling on them
 - 14 Check cable gland on tightness. The seal ring must completely encircle the cable.
 - 15 Screw the housing cover back on
- The electronics exchange is now finished.

7.4 Instrument repair

If a repair is necessary, please proceed as follows:

You can download a return form (23 KB) from our homepage at www.vega.com under: "*Downloads - Forms and certificates - Repair form*".

By doing this you help us carry out the repair quickly and without having to call back for needed information.

- Print and fill out one form per instrument
- Clean the instrument and pack it damage-proof
- Attach the completed form and, if need be, also a safety data sheet outside on the packaging
- Please ask the agency serving you for the address of your return shipment. You can find the respective contact data on our website www.vega.com under: "*Company - VEGA worldwide*"

8 Dismounting

8.1 Dismounting steps

**Warning:**

Before dismounting, be aware of dangerous process conditions such as e.g. pressure in the vessel, high temperatures, corrosive or toxic products etc.

Take note of chapters "*Mounting*" and "*Connecting to power supply*" and carry out the listed steps in reverse order.



With Ex instruments, the housing cover may only be opened if there is no explosive atmosphere present.

8.2 Disposal

The instrument consists of materials which can be recycled by specialised recycling companies. We use recyclable materials and have designed the electronics to be easily separable.

WEEE directive 2002/96/EG

This instrument is not subject to the WEEE directive 2002/96/EG and the respective national laws. Pass the instrument directly on to a specialised recycling company and do not use the municipal collecting points. These may be used only for privately used products according to the WEEE directive.

Correct disposal avoids negative effects on humans and the environment and ensures recycling of useful raw materials.

Materials: see chapter "*Technical data*"

If you have no way to dispose of the old instrument properly, please contact us concerning return and disposal.

9 Supplement

9.1 Technical data

General data

Material 316L corresponds to 1.4404 or 1.4435

Materials, wetted parts

– Process fitting - thread	316L
– Process fitting - flange	316L
– Process seal	Klingersil C-4400
– Tuning fork	316L
– Extension tube ø 43 mm (1.7 in)	316L

Materials, non-wetted parts

– Plastic housing	plastic PBT (Polyester)
– Aluminium die-casting housing	Aluminium die-casting AlSi10Mg, powder-coated - basis: Polyester
– Stainless steel housing - precision casting	316L
– Stainless steel housing, electropolished	316L
– Seal between housing and housing cover	NBR (stainless steel housing, precision casting), silicone (aluminium/plastic housing; stainless steel housing, electropolished)
– Light guide in housing cover (plastic)	PMMA (Makrolon)
– Ground terminal	316L

Process fittings

– Pipe thread, cylindrical (DIN 3852-A)	G1½ A
– American pipe thread, conical (ASME B1.20.1)	1½ NPT

Instrument weight (depending on process fitting) 0.8 ... 4 kg (0.18 ... 8.82 lbs)

Max. lateral load 600 N (135 lbf)

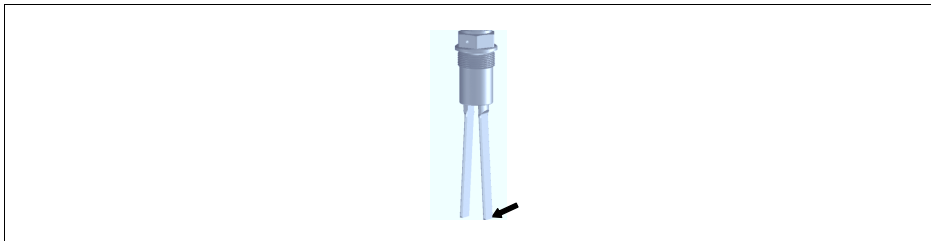

Fig. 29: Max. lateral load alongside fork side (narrow fork side)

Output variable

Output	Contactless electronic switch
Modes (switchable)	min./max.
Switching delay	
- When immersed	0.5 s
- When laid bare	1 s

Ambient conditions

Ambient temperature on the housing	-40 ... +80 °C (-40 ... +176 °F)
Storage and transport temperature	-40 ... +80 °C (-40 ... +176 °F)

Process conditions

Measured variable	Limit level of solids
Process pressure	-1 ... 25 bar/-100 ... 2500 kPa (-14.5 ... 363 psig)
VEGAWAVE 61 of 316L	-50 ... +150 °C (-58 ... +302 °F)
Process temperature (thread or flange temperature) with temperature adapter (option)	-50 ... +250 °C (-58 ... +482 °F)

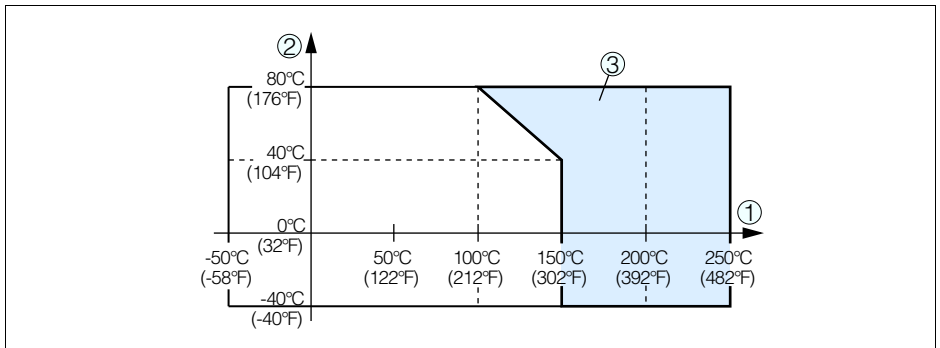

Fig. 30: Ambient temperature - Process temperature

- 1 Process temperature
- 2 Ambient temperature
- 3 Temperature range with temperature adapter

Product density

- Standard	> 0.02 g/cm ³ (0.0007 lbs/in ³)
- adjustable	> 0.008 g/cm ³ (0.0003 lbs/in ³)

Granular size

max. 10 mm (0.4 in)

Electromechanical data

Cable entry/plug (dependent on the version)

- Single chamber housing
 - 1 x cable entry M20 x 1.5 (cable: \varnothing 5 ... 9 mm), 1 x blind stopper M20 x 1.5; attached 1 x cable entry M20 x 1.5
 - or:
 - 1 x cable entry ½ NPT, 1 x blind stopper ½ NPT, 1 x cable entry ½ NPT
 - or:
 - 1 x plug M12 x 1; 1 x blind stopper M20 x 1.5 for wire cross-section up to 1.5 mm² (AWG 16)
- Spring-loaded terminals

Adjustment elements

Mode switch

- Min. Min. detection or dry run protection
- Max. Max. detection or overflow protection

Voltage supply

- Operating voltage 20 ... 253 V AC, 50/60 Hz, 20 ... 253 V DC
- Domestic current requirement approximately 3 mA (via load circuit)
- Load current
- Min. 10 mA
 - Max. 400 mA (at I > 300 mA the ambient temperature can be max. 60 °C/140 °F) max. 4 A up to 40 ms

Electrical protective measures

- Protection rating IP 66/IP 67
- Overvoltage category III
- Protection class I

Approvals

Instruments with approvals can have different technical data depending on the version.

That's why the associated approval documents have to be noted with these instruments. They are part of the delivery or can be downloaded under www.vega.com via "VEGA Tools" and "serial number search" as well as via "Downloads" and "Approvals".

9.2 Dimensions

VEGAWAVE 61 - housing

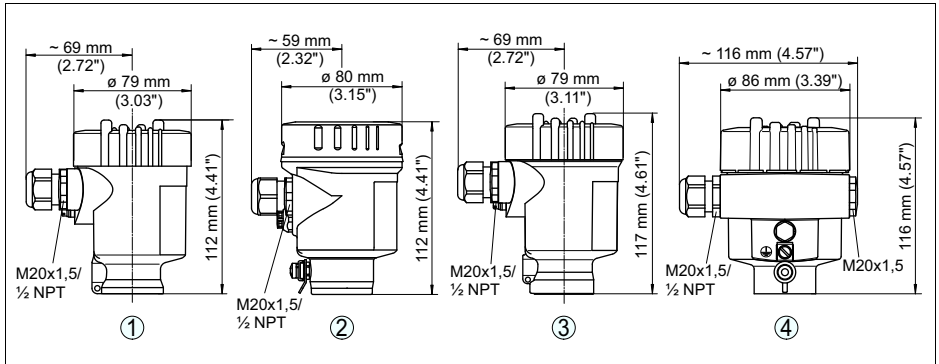

Fig. 31: Housing versions

- 1 Plastic housing
- 2 Stainless steel housing, electropolished
- 3 Stainless steel housing - precision casting
- 4 Aluminium housing

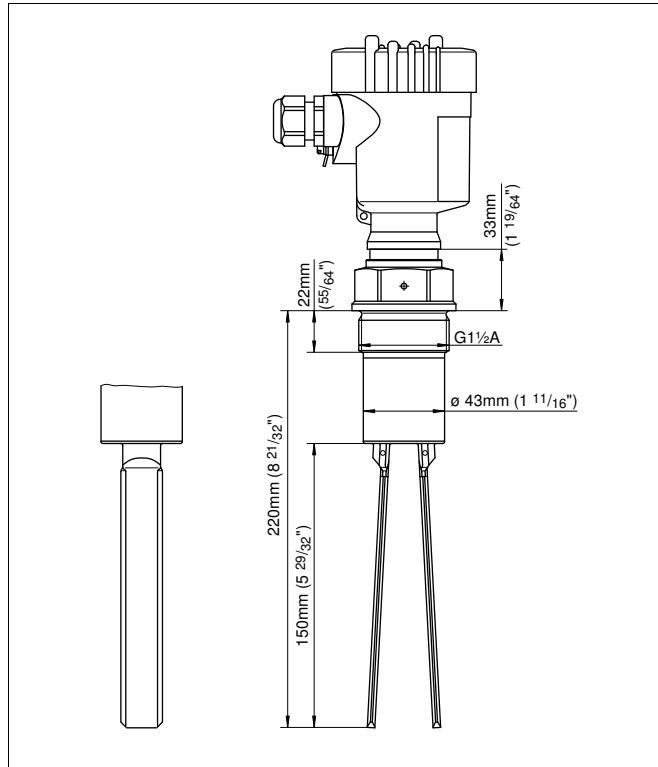

Fig. 32: VEGAWAVE 61, threaded version G1 1/2 A (DIN ISO 228/1)

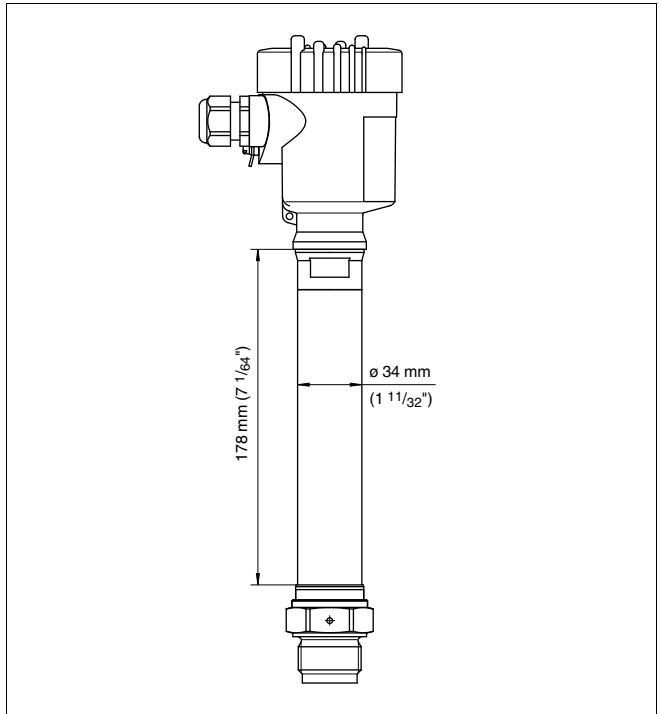

Fig. 33: Temperature adapter

9.3 Industrial property rights

VEGA product lines are global protected by industrial property rights.
Further information see <http://www.vega.com>.

Only in U.S.A.: Further information see patent label at the sensor housing.

VEGA Produktfamilien sind weltweit geschützt durch gewerbliche Schutzrechte.

Nähere Informationen unter <http://www.vega.com>.

Les lignes de produits VEGA sont globalement protégées par des droits de propriété intellectuelle.

Pour plus d'informations, on pourra se référer au site <http://www.vega.com>.

VEGA líneas de productos están protegidas por los derechos en el campo de la propiedad industrial.

Para mayor información revise la pagina web <http://www.vega.com>.

Линии продукции фирмы ВЕГА защищаются по всему миру правами на интеллектуальную собственность.

Дальнейшую информацию смотрите на сайте <http://www.vega.com>.

VEGA系列产品在全球享有知识产权保护。

进一步信息请参见网站<<http://www.vega.com>>。

9.4 Trademark

All the brands as well as trade and company names used are property of their lawful proprietor/originator.



Printing date:

VEGA Grieshaber KG
Am Hohenstein 113
77761 Schiltach
Germany
Phone +49 7836 50-0
Fax +49 7836 50-201
E-mail: info.de@vega.com
www.vega.com



All statements concerning scope of delivery, application, practical use and operating conditions of the sensors and processing systems correspond to the information available at the time of printing.

© VEGA Grieshaber KG, Schiltach/Germany 2012