

# VEGA

## Operating Instructions

### VEGACAP 62

with two-wire output

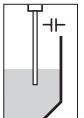

## Contents

### 1 About this document

1.1	Function . . . . .	4
1.2	Target group . . . . .	4
1.3	Symbolism used . . . . .	4

### 2 For your safety

2.1	Authorised personnel . . . . .	5
2.2	Appropriate use . . . . .	5
2.3	Warning about misuse . . . . .	5
2.4	General safety instructions . . . . .	5
2.5	CE conformity . . . . .	5
2.6	Safety information for Ex areas . . . . .	6
2.7	Manufacturer declaration . . . . .	6
2.8	Environmental instructions . . . . .	7

### 3 Product description

3.1	Configuration . . . . .	8
3.2	Principle of operation . . . . .	8
3.3	Adjustment . . . . .	10
3.4	Storage and transport . . . . .	10

### 4 Mounting

4.1	General instructions . . . . .	11
4.2	Mounting information . . . . .	12

### 5 Connecting to power supply

5.1	Preparing the connection . . . . .	15
5.2	Connection procedure . . . . .	15
5.3	Wiring plans, single chamber housing . . . . .	17
5.4	Wiring plans, version IP 66/IP 68, (1 bar) . . . . .	18
5.5	Start-up reaction . . . . .	18

### 6 Set up

6.1	General . . . . .	20
6.2	Adjustment elements . . . . .	20

### 7 Maintenance and fault rectification

7.1	Maintenance . . . . .	22
7.2	Fault rectification . . . . .	22
7.3	Exchange of the electronics module . . . . .	23
7.4	Instrument repair . . . . .	25

<b>8</b>	<b>Dismounting</b>	
8.1	Dismounting procedure . . . . .	26
8.2	Disposal . . . . .	26
<b>9</b>	<b>Supplement</b>	
9.1	Technical data. . . . .	27
9.2	Dimensions . . . . .	31
9.3	Industrial property rights. . . . .	34

# 1 About this document

## 1.1 Function

This operating instructions manual has all the information you need for quick setup and safe operation. Please read this manual before you start setup.

## 1.2 Target group

This operating instructions manual is directed to trained, qualified personnel. The contents of this manual should be made available to these personnel and put into practice by them.

## 1.3 Symbolism used



### Information, tip, note

This symbol indicates helpful additional information.



### Caution, warning, danger

This symbol informs you of a dangerous situation that could occur. Ignoring this cautionary note can impair the person and/or the instrument.



### Ex applications

This symbol indicates special instructions for Ex applications.



### List

The dot set in front indicates a list with no implied sequence.



### Action

This arrow indicates a single action.



### Sequence

Numbers set in front indicate successive steps in a procedure.

## 2 For your safety

### 2.1 Authorised personnel

All operations described in this operating instructions manual must be carried out only by trained specialist personnel authorised by the operator. For safety and warranty reasons, any internal work on the instruments must be carried out only by personnel authorised by the manufacturer.

### 2.2 Appropriate use

VEGACAP 62 is a sensor for level detection.

Detailed information on the application range of VEGACAP 62 is available in chapter "*Product description*".

### 2.3 Warning about misuse

Inappropriate or incorrect use of the instrument can give rise to application-specific hazards, e.g. vessel overfill or damage to system components through incorrect mounting or adjustment.

### 2.4 General safety instructions

VEGACAP 62 is a high-tech instrument requiring the strict observance of standard regulations and guidelines. The user must take note of the safety instructions in this operating instructions manual, the country-specific installation standards (e.g. the VDE regulations in Germany) as well as all prevailing safety regulations and accident prevention rules.

### 2.5 CE conformity

VEGACAP 62 is in CE conformity with EMC (89/336/EWG) and NSR (73/23/EWG).

Conformity has been judged acc. to the following standards:

- EMC:
  - Emission EN 61326: 2004 (class B)
  - Susceptibility EN 61326: 2004/Supplement A
- LVD: EN 61010-1: 2001

## 2.6 Safety information for Ex areas

Please note the Ex-specific safety information for installation and operation in Ex areas. These safety instructions are part of the operating instructions manual and come with the Ex-approved instruments.

## 2.7 Manufacturer declaration

In conformity with DIN EN 60079-14/2004, para. 5.2.3, point c1, the capacitive probe VEGACAP 62 is suitable for use in zone 2.

The operator must use the instrument correctly and follow the specifications of the following documents:

- this operating instructions manual
- this manufacturer declaration (24645)
- the applicable installation regulations

Max. increase of the surface temperature during operation:  
40 K (individual components in the instrument)

With an ambient temperature of +70°C (+158°F) on the housing and a process temperature of +70°C (+158°F), the max. ambient temperature during operation is +110°C (+230°F).

Measures for maintaining explosion protection during operation:

- Operate the instrument in the range of the specified electrical limit values. Permissible supply voltage: see "*Technical data*"
- Mount and operate the instrument in such a way that no ignition danger is expected by electrostatic charges. The process fitting, the plastic-coated/covered probe part or the housing are made of electrically non-conductive plastic (depending on the version).
- Make sure that the seal is mounted correctly between lower part of the housing and cover. Screw the cover on tightly.
- Make sure that there is no explosive atmosphere, if you want to operate the instrument with open cover
- Make sure that the cable gland is tight and strain-relieved. The outer diameter of the connection cable must be adapted to the cable gland. Tighten the pressure screw of the cable gland carefully.
- Cover unused openings for cable glands tightly

- Mount the instrument in such a position that the sensor cannot touch the vessel wall or vessel installations. Keep the influences of product movements in the vessel in mind.
- The surface temperature on the housing must not exceed the ignition temperature of the concerned explosive atmosphere

This instrument was judged by a person that fulfils the requirements acc. to DIN EN 60079-14.

## 2.8 Environmental instructions

Protection of the environment is one of our most important duties. That is why we have introduced an environment management system with the goal of continuously improving company environmental protection. The environment management system is certified acc. to DIN EN ISO 14001.

Please help us fulfil this obligation by observing the environmental instructions in this manual:

- Chapter "*Storage and transport*"
- Chapter "*Disposal*"

## 3 Product description

### 3.1 Configuration

#### Scope of delivery

The scope of delivery encompasses:

- VEGACAP 62 level sensor
- Documentation
  - this operating instructions manual
  - Ex specific safety instructions (with Ex versions), if necessary further certificates

#### Components

VEGACAP 62 consists of the following components:

- Housing cover
- Housing with electronics
- Process fitting with electrode

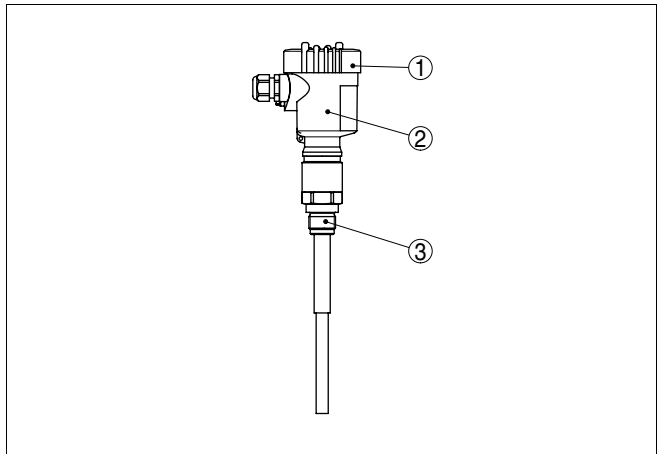

Fig. 1: VEGACAP 62 with plastic housing

- 1 Housing cover
- 2 Housing with electronics
- 3 Process fitting

### 3.2 Principle of operation

#### Area of application

VEGACAP 62 is a level sensor with partly insulated capacitive electrode for level detection.

VEGACAP 62 is very rugged and maintenance-free and can be used in all areas of industrial process technology.

Partly insulated probes such as VEGACAP 62 are preferably used in bulk solids.



The level switch can also be used in non-conductive liquids such as e.g. oil.

Typical applications are overflow and dry run protection.

The capacitive measuring principle places no special requirements on installation. Hence, many different applications can be equipped with VEGACAP 62.

The instrument can also be used problem-free in adhesive products.

### Physical principle

The probe, the measured product and the vessel wall form an electrical capacitor. The capacitance is influenced by three main factors:

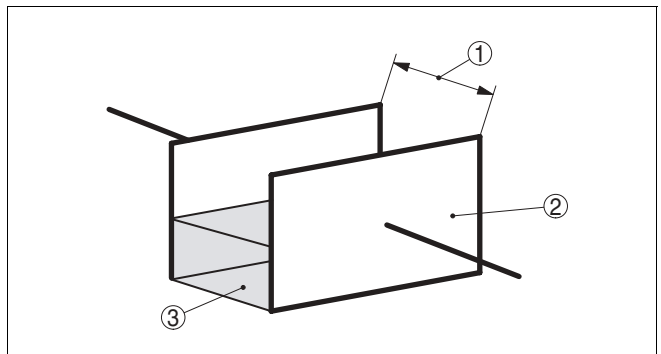

Fig. 2: Functional principle - Plate capacitor

- 1 Distance between the electrode surfaces
- 2 Size of the electrode surfaces
- 3 Type of dielectric between the electrodes

The probe and the vessel wall are the capacitor plates. The measured product is the dielectric. Due to the higher dielectric constant (DK value) of the product compared to air, the capacitance increases as the probe is gradually covered.

The capacitance change is converted by the oscillator into a switching command.

### Supply

Depending on your requirements, VEGACAP 62 with two-wire electronics can be connected to different signal conditioning instruments. Compatible signal conditioning instruments are listed under "*Technical data*".

The exact range of the voltage supply is specified in the "*Technical data*" in the "*Supplement*".

### 3.3 Adjustment

The probe can be adapted to the dielectric constant of the product directly on the electronics module.

A switching command can be triggered when the probe is covered or laid bare.

On the electronics module you will find the following indicating and adjustment elements:

- Signal lamp for indication of the device status.

### 3.4 Storage and transport

#### Packaging

Your instrument was protected by packaging during transport. Its capacity to handle normal loads during transport is assured by a test acc. to DIN 55439.

The packaging of standard instruments consists of environment-friendly, recyclable cardboard. For special versions, PE foam or PE foil is also used. Dispose of the packaging material via specialised recycling companies.

#### Storage and transport temperature

- Storage and transport temperature see "*Supplement - Technical data - Ambient conditions*"
- Relative humidity 20 ... 85 %

## 4 Mounting

### 4.1 General instructions

- Switching point** In general, VEGACAP 62 can be mounted in any position. The instrument must be mounted in such a way that the probe is at the height of the requested switching point.
- Handling** With screwed versions, the housing must not be used for screwing in! Tightening can cause damages on the locking piston of the housing.
- To screw in, use the hexagon above the thread.
- Moisture** Use the recommended cable (see chapter "Connecting to power supply") and tighten the cable gland.
- You can give your VEGACAP 62 additional protection against moisture penetration by leading the connection cable downward in front of the cable entry. Rain and condensation water can thus drain off. This applies mainly to mounting outdoors, in areas where moisture is expected (e.g. by cleaning processes) or on cooled or heated vessels.

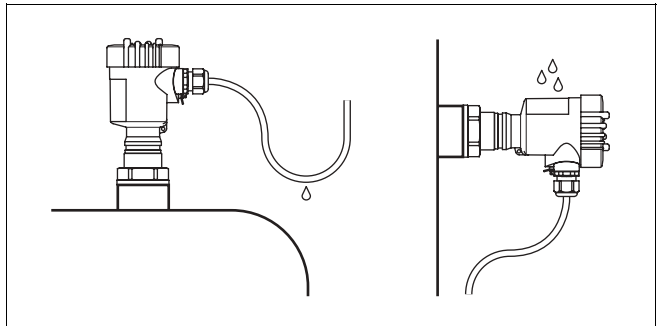

Fig. 3: Measures against moisture penetration

- Transport** Do not hold VEGACAP 62 on the probe. Especially with heavy flange versions or long rod versions, the sensor can be damaged simply by the weight of the instrument.
- Pressure/Vacuum** The process fitting must be sealed if there is gauge or low pressure in the vessel. Before use, check if the seal material is resistant against the measured product and the process temperature.

## 4.2 Mounting information

### Agitators and fluidization

Due to agitators, vibrations or similar, the level switch can be subjected to strong lateral forces. For this reason, do not use an overly long probe for VEGACAP 62, but check if you can mount a short level switch on the side of the vessel in horizontal position.

Extreme vibration caused by the system, e.g. due to agitators or turbulence in the vessel from fluidization can cause the probe of VEGACAP 62 to vibrate in resonance. If a longer rod version is necessary, you can secure the probe by fastening a suitable insulating brace or guy directly above the rod of the rod.

### Inflowing material

If VEGACAP 62 is mounted in the filling stream, unwanted false measurements may be generated. Mount VEGACAP 62 at a location in the vessel where no disturbing influence from e. g. filling openings, agitators, etc. can occur.

This applies particularly to instrument versions with a longer probe.

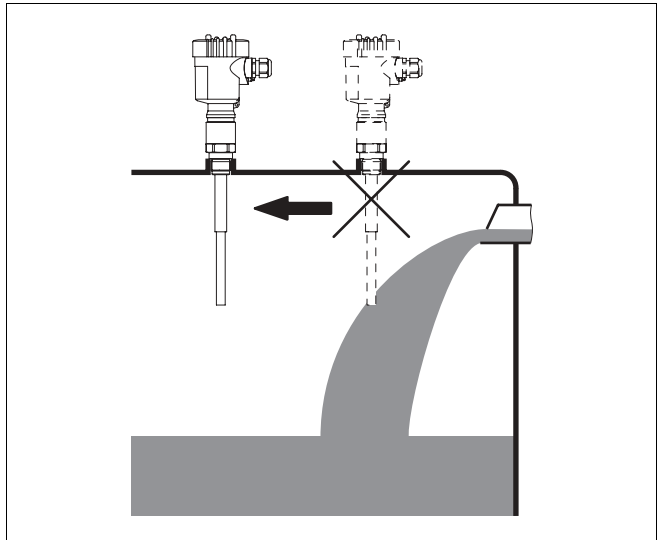

Fig. 4: Inflowing material

**Socket**

The probe should protrude into the vessel to avoid buildup. For that reason, avoid using mounting bosses for flanges and screwed fittings. This applies particularly to use with adhesive products.

**Material cone**

In silos with bulk solids, material cones can form which change the switching point. Please keep this in mind when installing the sensor in the vessel. We recommend selecting an installation location where the probe detects the average value of the material cone.

The measuring probe must be mounted in a way that takes the arrangement of the filling and emptying apertures into account.

To compensate measurement errors caused by the material cone in cylindrical vessels, the sensor must be mounted at a distance of  $d/6$  from the vessel wall.

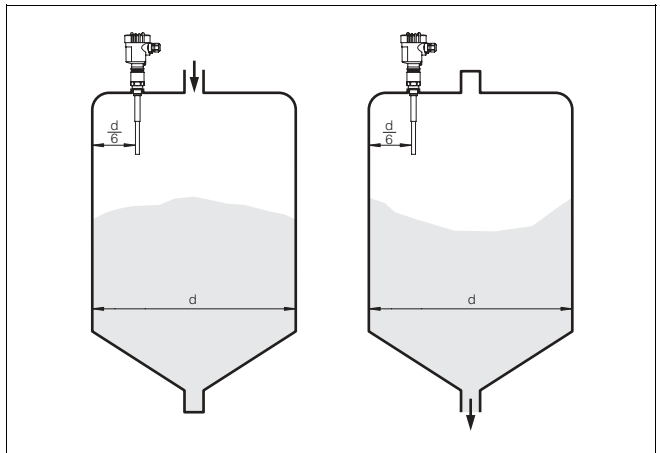

Fig. 5: Filling and emptying centered

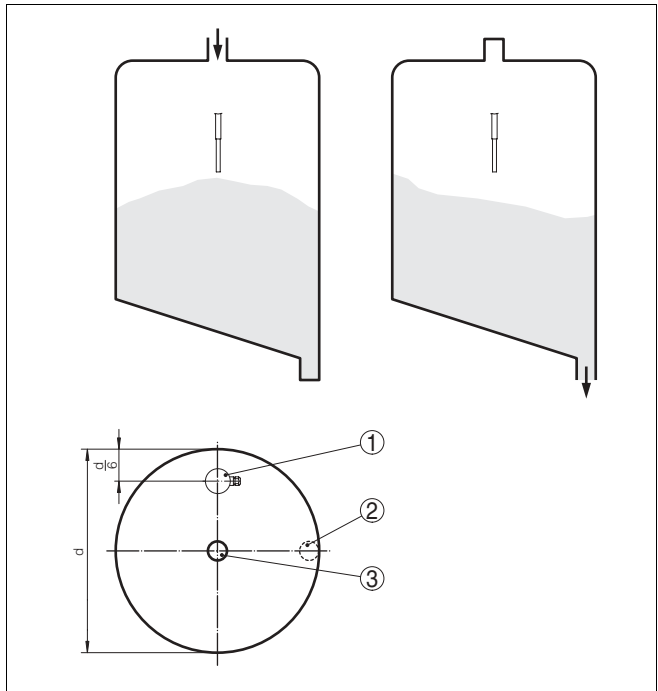

Fig. 6: Filling in the center, emptying laterally

- 1 VEGACAP 62
- 2 Emptying opening
- 3 Filling opening

## 5 Connecting to power supply

### 5.1 Preparing the connection

#### Note safety instructions

Always observe the following safety instructions:

- Connect only in the complete absence of line voltage

#### Take note of safety instructions for Ex applications



In hazardous areas you should take note of the appropriate regulations, conformity and type approval certificates of the sensors and power supply units.

#### Select power supply

Connect the power supply acc. to the following diagrams. Take note of the general installation regulations. As a rule, connect VEGACAP 62 to vessel ground (PA), or in case of plastic vessels, to the next ground potential. On the side of the instrument housing there is a ground terminal between the cable entries. This connection serves to drain off electrostatic charges. In Ex applications, the installation regulations for hazardous areas must be given priority.

The data for power supply are stated in the "*Technical data*" in the "*Supplement*".

#### Select connection cable

VEGACAP 62 is connected with standard cable with round wire cross section. An outer cable diameter of 5 ... 9 mm (0.2 ... 0.35 in) ensures the seal effect of the cable entry.

If cable with a different diameter or wire cross section is used, exchange the seal or use an appropriate cable connection.



In hazardous areas, only use approved cable connections for VEGACAP 62.

#### Select connection cable for Ex applications



Take note of the corresponding installation regulations for Ex applications.

### 5.2 Connection procedure



With Ex instruments, the housing cover may only be opened if there is no explosive atmosphere present.

Proceed as follows:

- 1 Unscrew the housing cover
- 2 Loosen compression nut of the cable entry

- 3 Remove approx. 10 cm (4 in) of the cable mantle, strip approx. 1 cm (0.4 in) insulation from the ends of the individual wires
  - 4 Insert the cable into the sensor through the cable entry
  - 5 Lift the opening levers of the terminals with a screwdriver (see following illustration)
  - 6 Insert the wire ends into the open terminals according to the wiring plan
  - 7 Press down the opening levers of the terminals, you will hear the terminal spring closing
  - 8 Check the hold of the wires in the terminals by lightly pulling on them
  - 9 Tighten the compression nut of the cable entry, the seal ring must completely encircle the cable
  - 10 Screw the housing cover back on
- The electrical connection is finished.

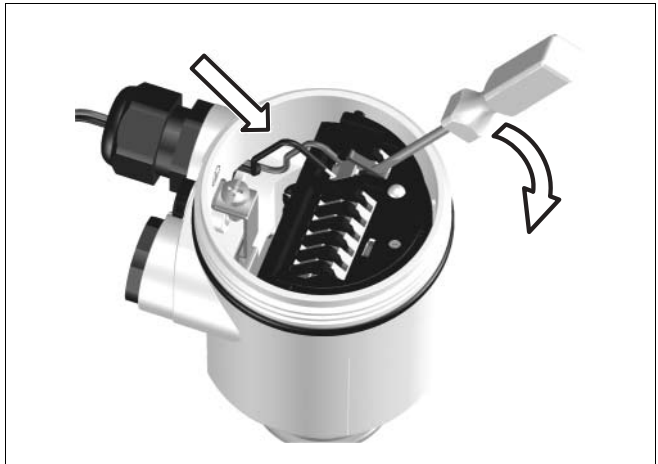

Fig. 7: Connection steps 5 and 6



### 5.3 Wiring plans, single chamber housing

#### Housing overview

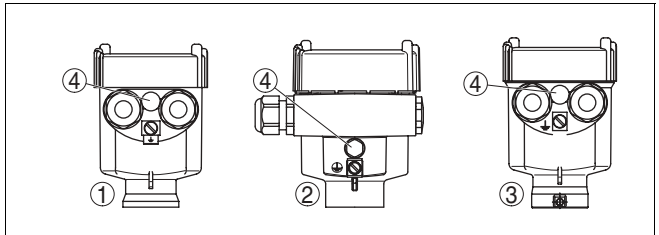

Fig. 8: Material versions, single chamber housing

- 1 Plastic (not with dust-Ex)
- 2 Aluminium
- 3 Stainless steel
- 4 Filter element for pressure compensation or blind stopper with version IP 66/ IP 68, 1 bar

#### Electronics and connection compartment

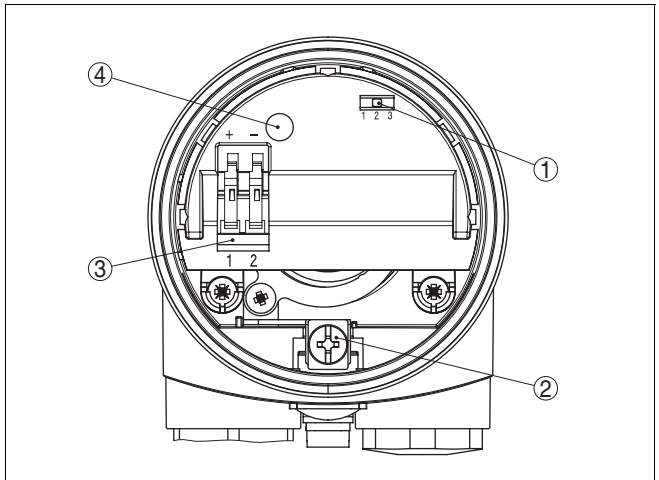

Fig. 9: Electronics and connection compartment

- 1 DIL switch for measuring range selection
- 2 Ground terminal
- 3 Terminals
- 4 Control lamp

#### Wiring plan

For connection to a signal conditioning instrument. The sensor is powered by the connected signal conditioning instrument. Further information is available in the "Technical data" in the "Supplement", Ex-technical data are available in the supplied safety information manual.

The wiring example is applicable for all suitable signal conditioning instruments.

Take note of the operating instructions manual of the signal conditioning instrument. Suitable signal conditioning instruments are listed in the "Technical data".

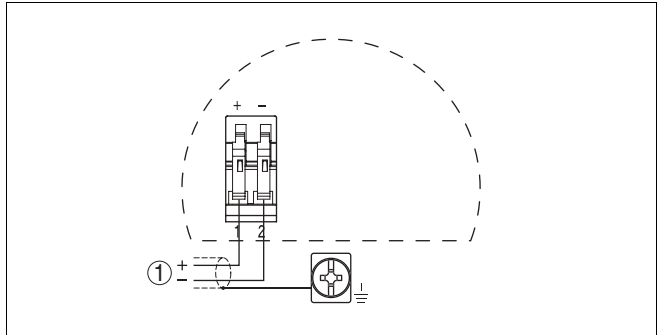

Fig. 10: Wiring plan  
1 Voltage supply

## 5.4 Wiring plans, version IP 66/IP 68, (1 bar)

### Wire assignment, connection cable

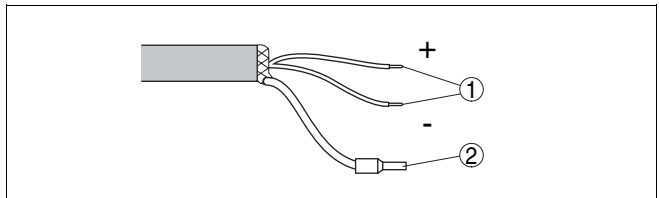

Fig. 11: Wire assignment, connection cable  
1 br (+) and bl (-) for power supply or to the processing system  
2 Screen

## 5.5 Start-up reaction

After connecting to voltage supply or after a voltage recurrence, the instrument passes a certain switch on routine.

By lowering the current value when switching on, the instrument can output briefly a fault message.

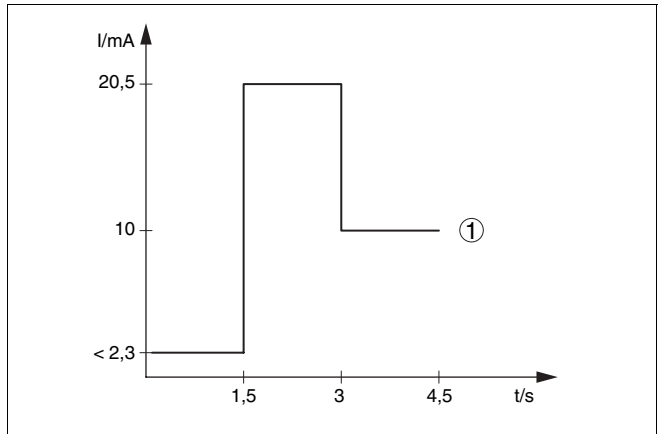

Fig. 12: Start-up reaction

1 Measured value

## 6 Set up

### 6.1 General

The numbers in brackets refer to the following illustrations.

#### Function/Configuration

On the electronics module you will find the following indicating and adjustment elements:

- DIL switch for measuring range selection
- Control lamp



#### Note:

As a rule, always set the mode with the mode switch of the signal conditioning instrument before starting setup VEGACAP 62. The switching output will change if you set the mode switch afterwards. This could possibly trigger other connected instruments or devices.

### 6.2 Adjustment elements

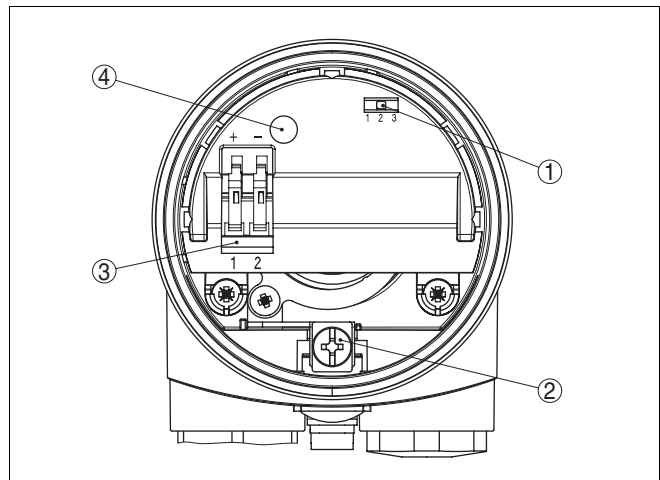

Fig. 13: Oscillator - two-wire output

- 1 DIL switch for measuring range selection
- 2 Ground terminal
- 3 Terminals
- 4 Control lamp

A failure can be displayed when the housing is closed (only plastic housing), see "Function chart".

**Note:**

Screw the housing cover tightly to the point where the inspection glass is above the control lamp (LED).

To adjust VEGACAP 62, first of all remove the housing cover.

**Measuring range selection switch (1)**

With the potentiometer on the signal conditioning instrument and the meas. range selection switch (1) on VEGACAP 62 you can change the switching point of the probe or adapt the sensitivity of the probe to the electrical properties of the product and the conditions in the vessel. This is necessary so that the level switch can also reliably detect products e.g. with very low or very high dielectric value.

Range 1: 0 ... 20 pF

Range 2: 0 ... 85 pF

Range 3: 0 ... 450 pF

**Signal lamp (4)**

Signal lamp for indication of the device status.

- green = instrument functions
- red (flashing) = failure

**Switching point adjustment**

The adjustment of the switching point is only possible in installed condition.

The detailed adjustment of VEGACAP 62 is described in the "*Operating instructions manual of the signal conditioning instrument*".

## 7 Maintenance and fault rectification

### 7.1 Maintenance

When used as directed in normal operation, VEGACAP 62 is completely maintenance-free.

### 7.2 Fault rectification

#### Causes of malfunction

VEGACAP 62 offers maximum reliability. Nevertheless faults can occur during operation. These may be caused by the following, e.g.:

- Sensor
- Process
- Supply
- Signal processing

#### Fault rectification

The first measure to be taken is to check the output signal. In many cases the causes can be determined and faults quickly rectified by doing this.

#### 24 hour service hotline

Should the following measures not be successful, please call in urgent cases the VEGA service hotline under the phone number **+49 1805 858550**.

The hotline is available to you 7 days a week round-the-clock. Since we offer this service world-wide, the support is only available in the English language. The service is free of charge, only the standard telephone costs will be charged.

#### Checking the switching signal

- ? VEGACAP 62 signals "covered" when the vibrating element is not submerged (overflow protection)
- ? VEGACAP 62 signals "uncovered" when the vibrating element is submerged (dry run protection)
  - Supply voltage too low
    - Check the power supply
  - Electronics defective
    - Push the mode switch (A/B) on the signal conditioning instrument. If the signal conditioning instrument then changes the mode, the instrument may be mechanically damaged. Should the switching function in the correct mode still be faulty, return the instrument for repair.
    - Check if there is buildup on the probe, and if so, remove it.

- Unfavourable installation location
  - Mount the instrument at a location in the vessel where no dead zones or mounds can form.
  - Check if the probe is covered by buildup on the socket.
- Wrong mode selected on the signal conditioning instrument
  - Set the correct mode on the mode switch of the signal conditioning instrument (A: overflow protection; B: dry run protection). Wiring should be carried out acc. to the quiescent current principle.
- ? Signal lamp flashes red
  - Electronics module of VEGACAP 62 has detected a failure
    - Exchange instrument or return it for repair

### 7.3 Exchange of the electronics module

In general, all oscillators of series CP60 can be interchanged. If you want to use an oscillator with a different signal output, you can download the corresponding operating instructions manual from our homepage under Downloads.

Proceed as follows:

- 1 Switch off power supply
- 2 Unscrew the housing cover
- 3 Lift the opening levers of the terminals with a screwdriver
- 4 Pull the connection cables out of the terminals
- 5 Loosen the two screws with a Phillips screwdriver (size 1)

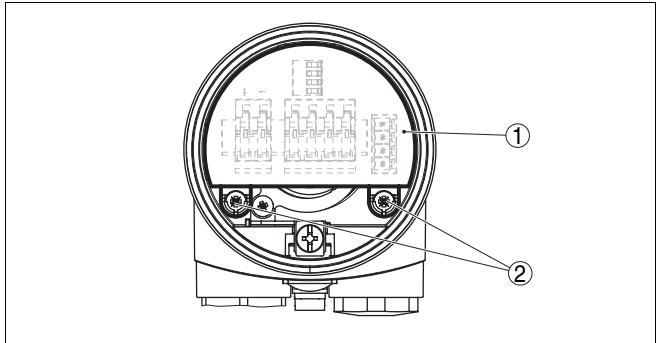

Fig. 14: Loosen the screws

- 1 Electronics module
- 2 Screws (2 pcs.)

- 6 Remove the old oscillator
- 7 Compare the new oscillator with the old one. The type label of the oscillator must correspond to that of the old oscillator. This applies particularly to instruments used in hazardous areas.
- 8 Compare the settings of the two oscillators. Set the adjustment elements of the new oscillator to the settings of the old oscillator.



#### Information:

Make sure that the housing is not rotated during the electronics exchange. Otherwise the plug may be in a different position later.

- 9 Insert the oscillator carefully. Make sure that the plug is in the correct position.
  - 10 Screw in and tighten the two screws with a Phillips screwdriver.
  - 11 Insert the wire ends into the open terminals according to the wiring plan
  - 12 Press down the opening levers of the terminals, you will hear the terminal spring closing
  - 13 Check the hold of the wires in the terminals by lightly pulling on them
  - 14 Check the tightness of the cable entry. The seal ring must completely encircle the cable.
  - 15 Screw the housing cover back on
- The electronics exchange is finished.



## 7.4 Instrument repair

If a repair is necessary, please proceed as follows:

From our homepage in the Internet [www.vega.com](http://www.vega.com), you can download a return form (23 KB) under: "*Downloads – Forms and Certificates – Repair form*"

By doing this you help us carry out the repair quickly and without having to call back for needed information.

- Print and fill out one form per instrument
- Clean the instrument and pack it damage-proof
- Attach the completed form and possibly also a safety data sheet to the instrument
- To get the address for your return shipment, please contact the agency serving you!

## 8 Dismounting

### 8.1 Dismounting procedure



**Warning:**

Before dismounting, be aware of dangerous process conditions such as e.g. pressure in the vessel, high temperatures, corrosive or toxic products etc.

Take note of chapters "*Mounting*" and "*Connecting to power supply*" and carry out the listed steps in reverse order.



With Ex instruments, the housing cover may only be opened if there is no explosive atmosphere present.

### 8.2 Disposal

VEGACAP 62 consists of materials which can be recycled by specialised recycling companies. We have purposely designed the electronic modules to be easily separable.

**WEEE directive 2002/96/EG**

This instrument is not subject to the WEEE directive 2002/96/EG and the respective national laws (in Germany, e.g. ElektroG). Pass the instrument directly on to a specialised recycling company and do not use the municipal collecting points. These may only be used for privately used products acc. to the WEEE directive.

Correct disposal avoids negative effects to persons and environment and ensures recycling of useful raw materials.

Materials: see "*Technical data*"

If you cannot dispose of the instrument properly, please contact us about disposal methods or return.

## 9 Supplement

### 9.1 Technical data

#### General data

---

Material 316 L corresponds to 1.4404 or 1.4435

#### Material wetted parts

– Process fitting - Thread	316L
– Process fitting - Flange	316L
– Process seal	Klingersil C-4400
– insulation (partly insulated)	PTFE
– Probe (rod PTFE partly insulated ø 12 mm/ø 0.47 in)	316L

#### Materials, non-wetted parts

– Housing	plastic PBT (Polyester), Alu-die casting powder-coated, 316L
– Seal ring between housing and housing cover	NBR (stainless steel housing), silicone (Alu/plastic housing)
– Ground terminal	316L

#### Weights

– with plastic housing	1150 g (40 oz)
– with Aluminium housing	1600 g (56 oz)
– with stainless steel housing	1950 g (69 oz)
– Rod weight ø 12 mm (ø 0.47 in)	900 g/m (10 oz/ft)

Sensor length (L)	0.2 ... 6 m (0.7 ... 20 ft)
Max. lateral load	10 Nm (7.4 lbf ft)
Max. torque (process fitting thread)	100 Nm (73 lbf ft)

---

#### Output variable

---

Output	Two-wire output
Suitable signal conditioning instruments	VEGATOR 521, 527, 620, 621 and 622
Output signal	>4 ... <20 mA (not standardised)
Fault signal	<2.3 mA
Integration time	
– when immersed	approx. 0.7 s
– when laid bare	approx. 0.7 s
– in case of failure	approx. 1 s

---

**Ambient conditions**

---

Ambient temperature on the housing	-40 ... +80°C (-40 ... +176°F)
Storage and transport temperature	-40 ... +80°C (-40 ... +176°F)

---

**Process conditions**

---

Process pressure	-1 ... 64 bar/-100 ... 6400 kPa (-14.5 ... 928 psi)
Process temperature VEGACAP 62 of 316L	-50 ... +150°C (-58 ... +302°F)
Process temperature (thread or flange temperature) with temperature adapter (option)	-50 ... +200°C (-58 ... +392°F)

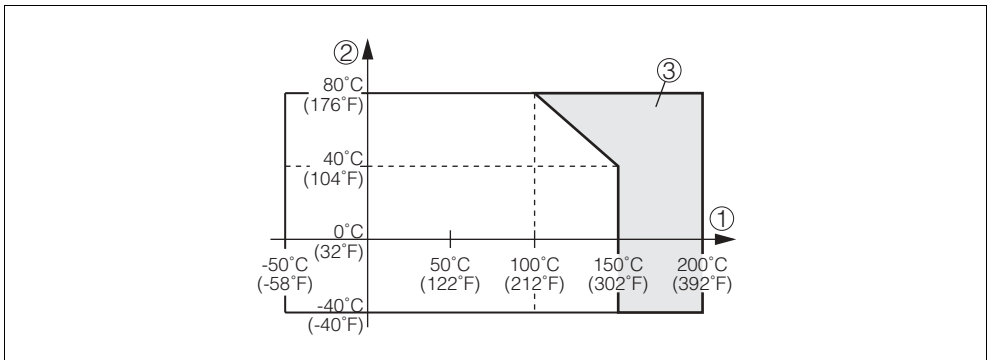

Fig. 15: Ambient temperature - Product temperature

- 1 Product temperature  
 2 Ambient temperature  
 3 Temperature range with temperature adapter

Dielectric figure >1.5

---

**Electromechanical data - version IP 66/IP 67 and IP 66/IP 68; 0.2 bar**

---

Cable entry/plug<sup>1)</sup>

- Single chamber housing
  - 1x cable entry M20x1.5 (cable-ø 5 ... 9 mm), 1x blind plug M20x1.5
  - or:
  - 1x closing cap ½ NPT, 1x blind plug ½ NPT
  - or:
  - 1x plug (depending on the version), 1x blind plug M20x1.5

<sup>1)</sup> Depending on the version M12x1, acc. to DIN 43650, Harting, Amphenol-Tuchel, 7/8" FF

Spring-loaded terminals for wire cross section up to 1.5 mm<sup>2</sup> (0.0023 in<sup>2</sup>)

---

### Electromechanical data - version IP 66/IP 68, 1 bar

---

#### Cable entry

- Single chamber housing
  - 1x IP 68 cable entry M20x1.5; 1x blind stopper M20x1.5
- or:
  - 1x closing cap ½ NPT, 1x blind plug ½ NPT

#### Connection cable

- Configuration four cores, one suspension cable, one breather capillary, screen braiding, foil, mantle
- wire cross section 0.5 mm<sup>2</sup>
- wire resistance <0.036 Ohm/m
- tensile load >1200 N (270 pounds force)
- Standard length 5 m (16.4 ft)
- max. length 1000 m (3280 ft)
- Min. bending radius 25 mm (at +25°C/+77°F)
- Diameter approx. 8 mm
- Colour - standard PE Black
- Colour - standard PUR Blue
- Colour - Ex version Blue

---

### Adjustment elements

---

#### DIL switch for measuring range selection

- range 1 0 ... 20 pF
- range 2 0 ... 85 pF
- range 3 0 ... 450 pF

---

### Voltage supply

---

Supply voltage 10 ... 36 V DC (via the signal conditioning instrument)

---

## Electrical protective measures

---

### Protection

- |   |                                     |
|---|-------------------------------------|
| – Plastic housing                                 | IP 66/IP 67                         |
| – Alu and stainless steel standard                | IP 66/IP 68 (0.2 bar) <sup>2)</sup> |
| – Alu and stainless housing, optionally available | IP 66/IP 68 (1 bar)                 |

Overvoltage category	III
----------------------	-----

Protection class	II
------------------	----

---

## Approvals (option)<sup>3)</sup>

---

ATEX II 1G, 1/2G, 2G EEx ia IIC T6

ATEX II 1/2 D, 2 D IP6X T<sup>4)</sup>

Overfill protection acc. to WHG (applied for)

Ship approvals (applied for)

<sup>2)</sup> Requirement to maintain the protection is the suitable cable.

<sup>3)</sup> Deviating data with Ex applications: see separate safety instructions.

<sup>4)</sup> Only in conjunction with Aluminium and stainless steel housing.

## 9.2 Dimensions

### Housing versions in protection IP 66/IP67 and IP 66/IP 68; 0.2 bar

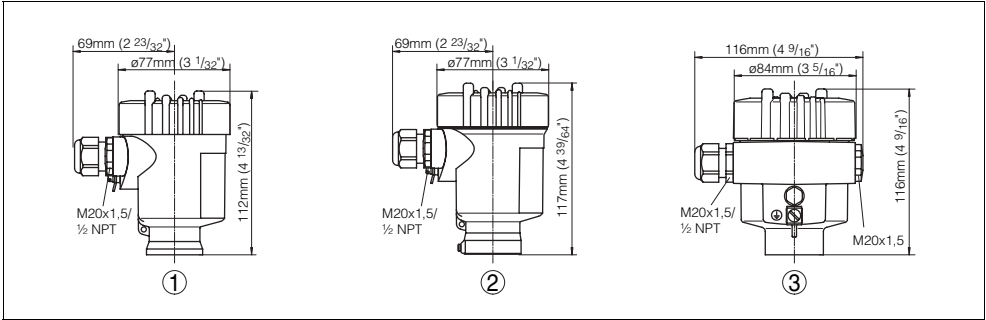

Fig. 16: Housing versions in protection IP 66/IP 67 and IP 66/IP 68; 0.2 bar

- 1 Plastic housing
- 2 Stainless steel housing
- 3 Aluminium housing

### Housing in protection IP 66/IP 68, 1 bar

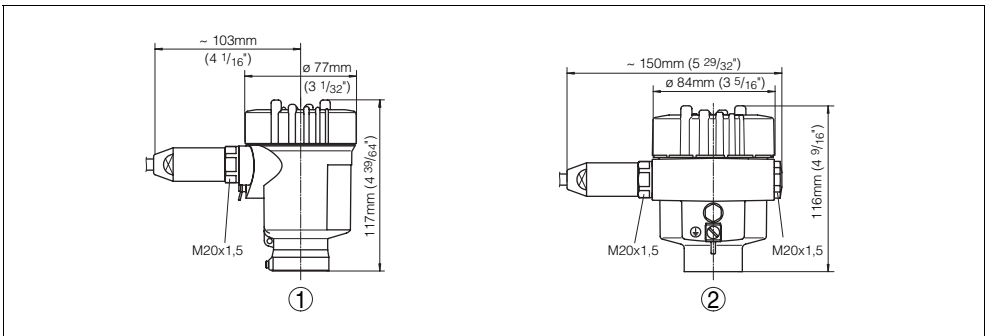

Fig. 17: Housing versions in protection IP 66/IP 68, 1 bar

- 1 Stainless steel housing
- 2 Aluminium housing

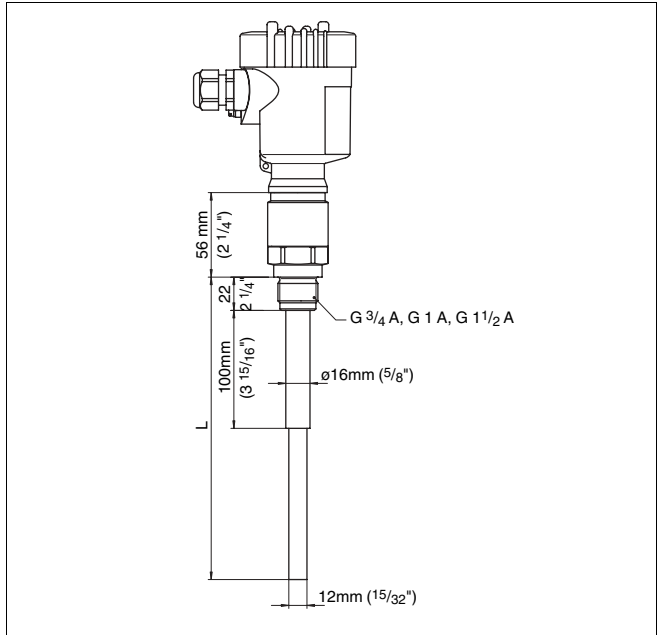

Fig. 18: VEGACAP 62 - Threaded version G1 A  
 L = Sensor length, see "Technical data"

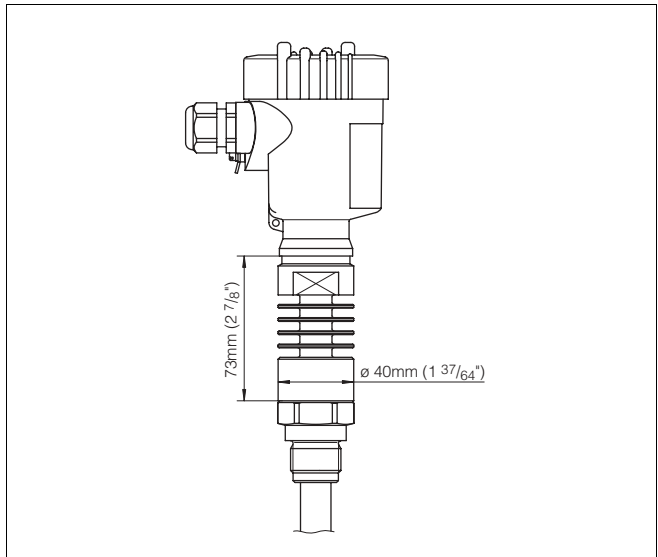

Fig. 19: Temperature adapter





### 9.3 Industrial property rights

VEGA product lines are global protected by industrial property rights.

Further information see <http://www.vega.com>.

Only in U.S.A.: Further information see patent label at the sensor housing.

VEGA Produktfamilien sind weltweit geschützt durch gewerbliche Schutzrechte.

Nähere Informationen unter <http://www.vega.com>.

Les lignes de produits VEGA sont globalement protégées par des droits de propriété intellectuelle.

Pour plus d'informations, on pourra se référer au site <http://www.vega.com>.

VEGA líneas de productos están protegidas por los derechos en el campo de la propiedad industrial.

Para mayor información revise la pagina web <http://www.vega.com>.

Линии продукции фирмы ВЕГА защищаются повсему миру правами на интеллектуальную собственность.

Дальнейшую информацию смотрите на сайте <http://www.vega.com>.

德（VEGA）系列产品在全球享有知保。  
一步信息网站<<http://www.vega.com>>。





VEGA Grieshaber KG  
Am Hohenstein 113  
77761 Schiltach  
Germany  
Phone +49 7836 50-0  
Fax +49 7836 50-201  
E-mail: [info@de.vega.com](mailto:info@de.vega.com)  
[www.vega.com](http://www.vega.com)



All statements concerning scope of delivery, application, practical use and operating conditions of the sensors and processing systems correspond to the information available at the time of printing.

© VEGA Grieshaber KG, Schiltach/Germany 2006