

# HP OCR + BARCODE Cartridge, SIMM or DIMM

## User Guide and Programming Manual

Revision 1.6

- sos8026S: For all HP LaserJet Series 4, 5 and 6 except L-Versionen, Color LaserJet, (Enhanced) Color LaserJet 5, CopyJet all DeskJet Series 1200 and 1600,*
- sos8026D: For all HP LaserJet Series 2100, 4000, 4050, 4100, 5000, 5100, 8000 8100, 8150, 9000 incl. all mfp Series Color LaserJet 4500, 4550, 4600*
- sos8026C: For all HP LaserJet Series 8500 and 8550*
- sos8026L: For all HP LaserJet Series 1200, 1220, 2200 and 3200*

---

## — Deutsche Anleitung

Dieses Dokument ist auch auf der beiliegenden Diskette als PDF Datei um Unterverzeichnis MANUALS verfügbar.

Um die Anleitung auszudrucken laden Sie die PDF Datei **MAN\_GR8026.PDF** in den Adobe Acrobat Reader 3.0 oder höher.

Falls Sie den Adobe Acrobat Reader nicht oder nur ein einer älteren Version besitzen, so können Sie diesen unter der Adresse <http://www.adobe.com/prodindex/acrobat/readstep.html> im Internet herunterladen.

Bitte beachten Sie, dass die aktuelle Anleitung immer im Internet auf unserer Homepage verfügbar ist.

---

## Notice

HEWLETT-PACKARD GMBH® (HP) AND STETHOS SYSTEMHAUS GMBH® (stethos) MAKE NO WARRANTY OF ANY KIND WITH REGARD TO THIS MATERIAL, INCLUDING, BUT NOT LIMITED TO, THE IMPLIED WARRANTIES OF MERCHANTABILITY AND FITNESS FOR A PARTICULAR PURPOSE.

HP and stethos shall not be liable for errors contained herein or for incidental or consequential damages in connection with the furnishing, performance, or use of this material, especially for the SIMM or DIMM module.

This document contains proprietary information which is protected by copyright. All rights are reserved. No part of this document may be photocopied, reproduced, or translated to another language without the prior written consent of HP and stethos.

The information contained in this document is subject to change without notice.

Microsoft®, Microsoft Windows™, Windows 95™, MS Windows and MS are registered Trademarks of Microsoft Corporation.

All named company names and/or products are trade names or registered trade names of the named companies.

© 1999 stethos Systemhaus GmbH®

Printed in Germany  
Version from: July 2002

---

## Content

Deutsche Anleitung .....	2
Notice .....	3
Content .....	4
Introduction .....	6
Installation .....	7
Installation Notes .....	7
Testing the Installation .....	8
Driver .....	9
Introducing the World of Barcodes .....	9
General Remarks .....	10
Alphanumerically Barcodes .....	10
Numeric Barcodes .....	10
Construction of the Codes .....	11
Readability .....	12
Programming .....	13
Conventions .....	13
Tips and Restrictions .....	13
Cursor positioning .....	14
Don't change the printing position .....	14
Selection of Barcodes and Fonts .....	15
First complete Example .....	16
Rotate for 90 degrees .....	16
Enlarging the Barcode .....	17
Reduce the barcode size using PCL .....	18
Independent scaling of Barcode width and height .....	19
Symbols .....	20
EURO-Symbols .....	21
LineDraw of „Bar Codes & More“ .....	21
OCR-A1 and OCR-B .....	22
Code-39 (3of9) .....	23
PZN Pharma-Central-Number .....	24
CODE-39 extended .....	25
CODE-93 .....	26
CODE-93 extended .....	28
Codabar .....	29

---

AIM Codabar .....	29
2of5 interleaved.....	30
German Post AG .....	32
2of5 industrial .....	33
2of5 matrix.....	33
EAN 13 .....	34
EAN 8 .....	35
EAN 10mil of „Bar Codes & More“ .....	36
EAN 13mil from „Bar Codes & More“ .....	36
EAN-Velocity.....	36
EAN 128 .....	36
UPC-A.....	37
UPC-E .....	38
EAN / UPC Addon 2.....	39
EAN / UPC Addon 5.....	40
MSI .....	41
USPS ZIP of „Bar Codes & More“ .....	42
CODE 128.....	43
UPC-128 .....	47
CMC 7 Font .....	48
MICR Font .....	49
KIX Code.....	50
4state KIX Code.....	50
Adresses .....	51
Macro (Form).....	52
VDA 4902 form .....	53
sos8026 and SAP R/2 and R/3 .....	54
Hex table .....	55
ASCII table .....	55
Trouble shooting? .....	56
Additional Products.....	57
Technical support.....	58

---

## Introduction

Thank you for purchasing the sos8026S or sos8026D font product. This modules do enhance the supported HP printers to print:

- OCR-A1 for check and bank transmission forms printing
- OCR-B as machine readable type
- Symbols like green point, recycling and much more
- Barcodes for data recognition
- A macro for testing of build in printable forms

The implementation requires, that the calculation of necessary check digits or the „Interleaving“ of the barcodes „2of5 interleaved“ and „Deutsche Post AG“ has to be done by the application software.

The sos8026S Font-SIMM or sos8026D Font-DIMM contains with the exception of the Letter Gothic all fonts of the HP Font-Cartridge „Bar Codes & More“, part number „C2053A #C06“. The Letter Gothic fonts are already implemented in the printer in scaling technology. For this reason the fonts were not added to the product. The OCR fonts do print characters like German „Umlaute“ and the „§“ sign.

The product is CE- and low voltage certified.

This package does contain:

- sos8026S Font-SIMM or sos8026D Font-DIMM
- Utility disk with drivers, examples and manuals
- English documentation

---

## Installation

---

**WARNING** For installation please follow the SIMM/DIMM installation advises in the printer's User Reference Manual. Especially follow all instructions to reduce the risk of damage the device by static electricity.

---

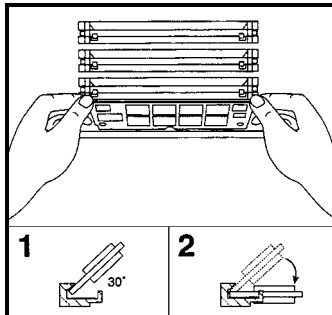

### Installation Notes

The sos8026S Font-**SIMM** work's in the following printer models:

- HP LaserJet 4x, 5x and 6P (excluding the L-Versions)
- HP Color LaserJet, HP (Enhanced) Color LaserJet 5x
- HP CopyJet
- HP DeskJet 1200Cx and 1600Cx

The sos8026D Font-**DIMM** can be used in the following printers:

- HP LaserJet Series 2100x, 4000x, 4050x, 4100x, 5000x, 5100x, 8000x, 8100x, 8150x, 9000x Color LaserJet 4500x, 4550x and 4600x

The sos8026C Font-**DIMM** can be used in the following printers:

- HP Color LaserJet Series 8500x and 8550x

The sos8026L Font-**DIMM** can be used in the following printers:

- HP LaserJet Series 1200x, 1200x, 2200x and 3200x

The board can be plugged into any free SIMM or DIMM slot. For installation please follow carefully the advises in the printer's User Reference Manual.

There is a 100% compatible **cartridge** product available for the HP LaserJet printers series III, IIID, IIP and IIISi.

---

## Testing the Installation

The generation of the **PCL Font List** at your printer confirms the proper installation of the SIMM or DIMM Board. The necessary steps are explained very detailed in the printer's User Reference Manual.

---

NOTE            The PCL Font List doesn't print readable barcode. The printer documents only the available fonts and their ESC sequences.

---

**PCL** is the shortage for **Printer Command Language** which is the name of the printer access language developed by HP. Further detailed documentation for any PCL command is published by HP in the manual „PCL5 printer language technical reference manual“.

A quick additional test for correct installation is to print the file **8026TEST.TXT** from the utility disk. Therefor the MS DOS-Command could be like this:

```
COPY /B A:\8026TEST.TXT LPT1
```

The utility disk contains for each font and barcode comprehensive test files, see subdirectory **TEST8026**. The following command does print all files to the printer device LPT1:

```
COPY /B A:\TEST8026\*. * LPT1
```

All files in this directory do generate for each type of font a printout with all available characters. The barcodes are readable with any proper device.



---

## Driver

All not scaleable (also named „**bitmapped**“) fonts (OCR-A1, OCR-B, Code EAN and 39) are the original fonts out of the cartridge „Bar Codes & More“, HP part number „**C2053A #C06**“ or out of the previous versions „**92286-X**“ and „**92286-W1**“.

The sos8026S Font-SIMM or sos8026D Font-DIMM is with some restrictions also usable in Microsoft Windows. The utility disk do contain two description files (\*.PCM) which add the new functionality to the standard HP printer drivers.

This method does only add printer fonts and no screen fonts. That's why there are no lines displayed on screen. The printout of barcodes without „interleaving“ and without check digits is easily possible.

- Windows 3.x    Open the Control Panel and select the printer, then Settings and Printer Settings. Select Fonts, New, Add, Floppy disk drive, and copy the two description files to the left window. After exiting the font installation window, both „modules“ are displayed at the very end of the cartridges/SIMM/DIMM selection list box. Activate the requested module(s).
- Windows 95    The installation is quite similar to Windows 3.x. Just in case the systems doesn't recognize the description files, install the Windows 3.x printer driver.
- Windows NT    The installation disk does also contain a LaserJet printer driver developed by HP. See the readme file in the directory WIN\_NT for further information.
- MS Word        The Utility disk contains a Microsoft Word Macro for barcode and mail merge printing, see subdirectory WINWORD. The macro also contains in „Basic“ for all barcodes the routines for interleaving and check digits.
- NOTE:**        If you need to enter any character above 127 via the keyboard, you need to add a zero in front of the ASCII value, like Alt+0129. Also teh charaters above 127 are repeated at position 200.

## Introducing the World of Barcodes

---

## General Remarks

Barcodes do influence our daily business very much. In deed, each product in the food stores is labeled with the EAN barcode. This unique mark helps for inventory and detailed customers bills.

Other barcodes do help to minimize the letter and package delivery time, and in case of being lost, the system does know where the part was at least recognized.

The following list explains the major benefits and disadvantages of the different barcode types:

### Alphanumerically Barcodes

- |                        |  |
|------------------------|--|
| Code 39<br>(also 3of9) | <ul style="list-style-type: none"><li>+ Easy construction, reliable readable</li><li>+ Possibly most used code</li><li>+ Self proofing, even without check digits</li><li>+ Additional check digit possible</li><li>+ US-ASCII Table can be coded</li><li>- Needs a lot of space</li></ul> |
| Code 93                | Pretty similar to Code 39, needs less space.   |
| Code 128               | <ul style="list-style-type: none"><li>+ US-ASCII Table can be coded</li><li>+ Compression routine for numeric contents</li><li>+ No reading failure because of check digit</li><li>- Complex Usage</li></ul>   |
| UCC 128                | Similar to Code 128, with an additional control sign   |
| EAN 128                | Similar to Code 128, with an additional control sign   |

### Numeric Barcodes

- |         |  |
|---------|--|
| UPC/EAN | <ul style="list-style-type: none"><li>+ High Information on few space</li><li>+ Readable up to an angle of 45 degrees</li><li>+ No reading failure because of check digit</li><li>- Only 8 or 13 digits</li><li>- Very tiny tolerances</li></ul> |
|---------|--|

---

Code 2of5 matrix, Code 2of5 industrial, Codabar	+ High tolerances + Additional check digit possible
Code 2/5 interleaved	+ Very high information on very few space + Additional check digit possible - Tiny tolerance
MSI	+ Additional check digit possible + High tolerances - Needs lots of Space

### Construction of the Codes

Each barcode do start with a **guard bar** (start character), followed by the **message**, and the **check digit** (if requested or necessary) and ends with **another guard bar** (stop character). Some types of barcodes do have the same start and stop character.

Around the printed barcode is mostly requested a **space zone** (not printed area). This zone is either defined by the reading application or part of the specification of the barcodes reading system. Usually about 5 to 6 mm space should be enough.

Some types of barcode can be used in different modes:

- With and without check digit
- Different proportions (see next chapter)
- Expansion for upper- and lower case characters
- With and without readable text

As explained, some of the codes do have the possibility to add an optional check digit. Those sign is always represented by a regular character out of the barcode character set. If the reading device is not programmed for proof checking the **optional check digit** is mostly treated as a regular „message“ sign.

---

## Readability

Within certain tolerances the statement, that the bigger (wider) the code the better the readability, is quite true. Some barcodes do quite good in printing a lot of information on a small space, like for example Code 2of5 interleaved or Code 128 C.

Some type of barcodes can be used with different **proportions**, also known as **module width**. This width is defined by the smallest bar/space. A proportion of 1:3 claims, that the next thicker bar/ space is three times wider then the smallest one. Of course a code with module width 1:3 compared to 1:2 needs more printing space, but on the other hand proportion 1:3 is easier readable.

---

NOTE	Mostly very thin bars are printed a little big more bold than they should be. This is not very helpful for the readability of the code, but can be compensated by reducing the <b>toner density</b> .
------	---

---

On some printers, a slight degradation of image quality may occur immediately after replacing the toner cartridge. To assure that the barcode images are printed for later reading with sufficient quality, follow these instructions:

- Be certain that the storage and care instructions for toner cartridge had been fulfilled.
- Be sure to change the EP cartridge when necessary. Carefully follow the installation instructions.
- Check on regular bases the print quality through the first 50 pages.

The used **Paper** or **transparency Film** do have a major influence on the later readability of the barcode. The basic paper color should provide a good **contrast** to the toner color. Rub with your finger nails on the paper, the tone should not take off.

In order to print barcodes with a small module width, please use printer with a higher resolution (600 dpi).

---

## Programming Conventions

In the following some characters are shown in **Decimal Form**. These values are always surrounded by smaller and greater as signs, some examples are:

- <27> defines the ESC character, or hexadecimal 0x1b.
- <65> is defined in the ASCII Table as characters A, or hex 0x41

### Tips and Restrictions

- The differentiation of the character 'O' and the number '0' is sometimes in the control sequences (**ESC-Sequence**) not very clear. On the print out of the PCL Font List each zero is marked with an additional slash.
- Does the printer driver of your software allow for additional fonts only to enter a selection and a de-selection sequence, please note the following:  
Because of the font technology of the product, there might be no way to access any type of barcode with „interleaving“ and/or check digits (for example like **SAP R/2 and R/3** and **KHK DOS-Software**).  
For those applications we do recommend the intelligent **JetCAPS BarSIMM®**.
- An interleaving and check digit example for all type of barcodes can be found in MS Word „basic“ on the utility disk.
- The sos8026S Font-SIMM or sos8026D Font-DIMM and the BarSIMM do only support the printer language PCL.
- If you are not familiar to the barcode technology, it is recommended to start with the Code 39. In the beginning you shouldn't use any special sign and also try avoid the space character. Just reduce the message information to upper case characters and numbers, and frame it with the multiplication sign like:

\*TEST4711\*

results in

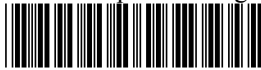

---

## Cursor positioning

In order to move the cursor on the printers page, PCL offers three different possibilities. One of the those methods depend on the actual resolution (300/600 dpi), another on the actual used font. Therefore we do recommend to use the only positioning command, which is fully independent of any actual printer setting:

<27>&a###H (Horizontal) and <27>&a###V (Vertical)

The value ### is measured in 1/720 Inch (=2.54cm). The decimal sign is the point. As an example <27>&a566.9h1133.86V positions the cursor about 2 cm of the left and 4 cm of the top **printing origin**.

---

Note	The printing origin depends upon the hardware restrictions of the print engine. For HP laser printer the printing origin is about 6 mm from top and left of the physical page.
------	--

---

A plus or minus sign in front of the positioning value causes the printer to perform at the actual cursor position a **relative movement**. For example <27>&a-720V positions the cursor 1 inch towards the top of page.

---

Note	If two followed ESC-Sequences do have the same first three characters, the last character of the first sequence could be written in lower case, and the next three characters can be eliminated.
------	--

---

## Don't change the printing position

PCL is able to store any cursor position, reposition the cursor and return to the initial position.

<27>&fS (**Push Cursor**)

.... any PCL statement including cursor positioning ...

<27>&f1S (**Pop Cursor**)

---

## Selection of Barcodes and Fonts

Printing barcode is equivalent to change to any other font. This requires at least three different steps: The ESC-Sequence for **addressing** the font, the **message** itself and the selection of the **follow-up font**. For example:

Selection of Code 39 20pt	<27>(10Q<27>(s1p20v0s0b10004T
Message information	*12345*
Standard Courier 10pt	<27>(10U<27>(s0p10h12v0s0b4099T

The necessary PCL sequences for barcode and standard build in font selection are listed in the PCL Font List.

An easier and faster way to select any font is to use the **primary** and **secondary** font set.

PCL allows to define two font sets at the „same“ time. Secondary fonts are defined with the same ESC Sequence, but instead of the opening the closing ‘)’ parenthesis has to be used. In order to switch between the sets, use **Shift-Out** <14> for the secondary and **Shift-In** <15> to return to the primary setting.

The advantage of this method is to keep the definition of the primary font. An example:

Code 39 as secondary	<27>)10Q<27>)s1p12vsb10004T
Standard font as primary	<27>(10U<27>(s0p10h12vsb4099T
Printout: Part No	<14>*12345*<15> Storage <14> *4711* <15>

Part No  Storage 

---

### First complete Example

The file EXAMPLE1.TXT in the root directory of the utility disk does print a slightly different example. This file can be loaded and printed with any ASCII Editor like for example the DOS Editor EDIT.

... normal printing data	
<27>&fS	Save the original printing position
<27>&a###h####V	Set the barcode printing position
<27>)10Q<27>)a1p20vsb10004T	
	Select code 39, secondary font set
<14>	Activate the secondary font set
*12345*	Message, including start-stop-signs
<15>	Return to the primary font set
<27>&f1S	Return to original print position
further printing data ...	
<12>	Form feed.

---

NOTE	The single ESC-Sequences in the description above have to be entered all in one flow, and not row by row. Any CR-LF influences the positioning of the printer cursor!
------	---

---

A small trick is necessary to enter with the DOS editor EDIT special characters like <27>, <14> and <15>. First press the combination for keyboard entry: Strg-P, than hold down the ALT-key and enter the ASCII number on the right number pad of your keyboard.

### Rotate for 90 degrees

In order to rotate the barcode or any other font to 90 or 240 degrees, PCL offers the sequences <27>&a90P and <27>&a240P.

The printer needs to receive <27>&aP to return to the normal printing direction.

The file EXAMPLE2.TXT on the utility disk prints an example.



---

## Enlarging the Barcode

The next example demonstrates one way to enlarge a barcode by printing the same code twice, but at a moved up/down position.

<27>)10Q<27>)a1p20vsb10000T

Select code 39, secondary font set

... normal printing data

<27>&fS

Save the original printing position

<27>&a####h####V

Set the barcode printing position

<14>

Activate the secondary font set

<27>&fS

Save the barcode printing origin

<27>&a-##V

Move the printing position up

\*12345\*

Message, including start-stop-signs

<27>&fIS

Return to the barcode printing origin

In order to even further enlarge the barcode you may restart the loop at „Save the barcode printing origin“ and move the printing position further up.

\*12345\*

Message, including start-stop-signs for the lowest strip

<15>

Return to the primary font set

<27>&fIS

Return to original print position

further printing data ...

---

NOTE

If you would like to get readable text below the barcode, change before printing the last strip to the font with readable text.

---

The file EXAMPLE3.TXT on the utility disk prints an example.

Please keep in mind, that the most important barcodes are implemented into the sos8026 product in four different sizes.

---

## Reduce the barcode size using PCL

This example demonstrates how to reduce the size of the barcode. This is only necessary if the code is already too tall at it's needed width:

<27>)10Q<27>)a1p20vsb10004T

... normal printing data

<27>&fS

<27>&a###h###V

<14>

<27>&fS

\*12345\*

<27>&f1S

<15>

<27>&a-##V

<27>\*c###h###v1P

<27>&f1S

further printing data ...

Select code 39, secondary font set

Save the original printing position

Set the barcode printing position

Activate the secondary font set

Save the barcode printing origin

Message, including start-stop-signs

Return to the barcode printing origin

Return to the primary font set

Move printing position to top of barcode

Print a white rectangular, ### in 1/720 Inch.

Return to original print position

---

### NOTE

If the printed barcode is so large, that it is already printing in the upper text, just set the barcode printing position lower. In this case you have to cut the bottom part of the code.

---

The file EXAMPLE4.TXT on the utility disk prints an example.

---

## Independent scaling of Barcode width and height

HP-GL/2 is able to print any scaleable PCL font (not the „bitmapped“ fonts out of the „Bar Codes & More“) in any user defined width/height ratio. Therefore you need only one ESC sequence to print the code.

---

NOTE                    The new HP Laser printer are only able to scale the Y direction.  
                             This means you should set in PCL the font already to the requested  
                             X width.

---

<27>&fS	Save the original printing position
<27>&a####h####V	Set the barcode printing position
<14>	Activate the secondary font set
<27>*c28D	Definition of a new font ID: 28
<27>)10Q<27>)s1p20vsb10004T	Select code 39, secondary font set
<27>*c6F	Assign the font to ID 28
<15>	Return to the primary font set
<27>%1BSP1;SA;FN28;	Start HP-GL/2, keep the PCL printing position, use Pen 1, secondary font set and font ID 28
AD1,341	Choose again 10Q for symbol set
DT#;	Definition of the character ‘#’ as end of text. Is this sign used in your message data, take any other unused character, Like ‘.’.
SI###,###;	Define the new width and height in cm of the font, for example SI1,5.5;
LB*12345*#;	Prints the message with the LB command, ended by the ‘#’ sign
<27>%0A	Return to PCL
<27>&f1S	Return to original print position

The file EXAMPLE5.TXT on the utility disk prints an example.

## Symbols

### ESC-Sequence

<27>(10Q<27>(s1p###vsb10400T

### font size in point

D-L									
M-U									
V-]									
-									
a-i									
j-r									
s-t									

### Examples

Green point <14><27>)10Q<27>)s1p20vsb10400TE<15>  
 with text <14><27>)10Q<27>)s1p20vsb10400TDE<15>  
 gray arrows <14><27>)10Q<27>)s1p20vsb10400Td  
 <27>\*c15G <27>\*v2Te<27>\*vT<15>  
 Recycling logo <27>(10Q<27>(s1p20vsb10400Tghij<8>123  
 Explosion <14><27>)10Q<27>)s1p20vsb10400Tst<15>

### ESC-Sequence

<27>(10Q<27>(s1p###vs3b10400T

### font size in point

33-42									
43-51									
52-60									
=									
A-G									
H-P									
Q-Y									
Z-[ ]									
b-e									
f-n									
o-q									

Those symbols are coming from the font library of Elsner und Flake Fontinform GmbH, Hamburg. Those fonts are only available for the HW solution.

## EURO-Symbols

<27>(\_\_\_\_<27>(s1p###vsb10452T      Symbols scalable

\_\_\_\_ any symbol set, see User Reference Manual

### font size in point

A-G	€	€	€	£	¢	¤	¥
a-g	€	€	€	€	€	€	€
h-l	€	€	€	€	€		

### Example I

European currency symbol inverse:

<14><27>)10U<27>)s1p20vsb10452TC<15>

## LineDraw of „Bar Codes & More“

ESC-Sequence

<27>(0B<27>(sp10h12vsb0T

32	33	34	35	36	37	38	39	40	41	42	43
44	45	46	47	48	49	50	51	52	53	54	55
56	57	58	59	60	61	62	63	64	65	66	67
68	69	70	71	72	73	74	75	76	77	78	79
80	81	82	83	84	85	86	87	88	89	90	91
92	93	94	95	96	97	98	99	100	101	102	103
104	105	106	107	108	109	110	111	112	113	114	115
116	117	118	119	120	121	122	123	124	125	126	127

This font is implemented for compatibility reasons to the HP font cartridge Bar Codes & More.

## OCR-A1 and OCR-B

### ESC-Sequences

<27>(00<27>(sp10h12vsb104T      OCR-A of „Bar Codes & More“  
 <27>(10<27>(sp10h12vsb110T      OCR-B of „Bar Codes & More“  
 <27>(\_\_\_\_<27>(s1p###vsb10451T      OCR-A scaleable  
 <27>(\_\_\_\_<27>(s1p###vsb10450T      OCR-B scaleable  
 \_\_\_\_ any symbol set, see User Reference Manual\*  
 ### font size in point

### Valid OCR-A1 characters

	0	1	2	3	4	5	6	7	8	9	10	11	12	13	14	15
32		!		#	\$	%	&		(	)	*	+	,	-	.	/
48	0	1	2	3	4	5	6	7	8	9	:	;	<	=	>	?
64	@	A	B	C	D	E	F	G	H	I	J	K	L	M	N	O
80	P	Q	R	S	T	U	V	W	X	Y	Z	(	\	)	^	~
96	µ	a	B	c	d	e	f	g	h	i	j	k	l	M	n	o
112	P	q	R	s	t	u	v	w	x	y	z	{		}	²	
128		ü			ä										Ä	
144					Ö				Ö	Ü				B		
160													ä		Ö	ü
208								Ä		Ö	Ü				B	
224		B														

OCR-B of the „Bar Codes & More“ does print the same characters, except <95>, <96> and <126>.

### Example for printing checks with OCR-A1

<27>)00<27>)sp10h12vsb104T<14>  
 <27>&a1400H<Check number><126>  
 <27>&a2500H<Account number><96>  
 <27>&a4250H<swift code><126>01<96>

00001126802²      289301009µ      60390000²      01µ

\* Please note, that the symbol set 10Q is used for the shown table. If you want to use another table, the character positioning might be different.

---

## Code-39 (3of9)

### ESC-Sequences

<27>(10Q<27>(s1p###vsb10000T	scal. no readable text	P1:3
<27>(10Q<27>(s1p###vsb10001T	scal. no readable text	P1:3
<27>(10Q<27>(s1p###vsb10004T	scal. readable text	P1:3
<27>(10Q<27>(s1p###vs*b10006T	scal. no read. text	P1:2.5
<27>(10Q<27>(s1p###vsb10007T	scaleable read. text	P1:2.5
<27>(10Q<27>(s1p###vsb10003T	scal. no readable text	P1:2
<27>(10Q<27>(s1p###vsb10005T	scaleable read. text	P1:2
<27>(0Y<27>(s0p8.1h12v0s0b0T	of „Bar Codes & More“	
<27>(0Y<27>(s0p4.6h12v0s0b0T	of „Bar Codes & More“	

### Font size in point  
\* 0->3 different Height/Width relations.

### Valid characters

01-89 AB-YZ \$ % + - . / space

PCL is unfortunately not able to print the space sign (it just performs a cursor movement). The scaleable fonts do have the space mapped to character '@' (<64>) and the bitmapped fonts to the comma sign.

The Code with the proportion 1:2 and readable text do have the start-/stop sign also on the characters '(' and ')'. However, both characters do not print the '\*' sign below. The bar length of the closing parenthesis are even longer than the other ones, so the readable message text looks like embedded.

### Usage

The message has to be embedded between the start-/stop bar '\* <42>'. The recommended minimum barcode height is 20 mm or 25% of the width. The amount of message characters is only limited by capabilities of the reading device.

### Check digit (Optional)

The type of character coding already enables the reader to verify the read information. However, on request there can be added a **check digit** right after the message information and before the stop bar.

---

In order to calculate the check digit each message character is related with a unique **reference number**: 0-9 gets 0-9, A-Z gets 10-35, minus 36, point 37, space 38, dollar sign 39, slash 40, plus 41 and percentage 42. The start-/stop sign is not referenced. The check digit is finally calculated **modulo 43** out of the sum of the reference numbers.

**Example:** CODE12 results in \*CODE12N\*  
 $12+24+13+14+1+2 = 66 / 43 = 1 \text{ Rest } 23 = N$

**Example**

'66789 ER' proportion 1:2 and readable text   
<14><27>)10Q<27>)s1p20vsb10005T\*66789@ER\*<15>

## PZN Pharma-Central-Number

### Usage

This code is based upon the Code 39. In addition a minus sign '-' has to follow direct after the start bar. The message length is fixed to six digits, followed by a check digit and the regular code 39 stop bar.

The code should be used with proportion 1:3. For module width larger then 0,5 mm the proportion 1:2 is recommended.

The minimum code size is 6 mm.

### Check digit

Each of the six message numbers has to be multiplied with it's position plus 1. The check digit is calculated **modulo 11** out of the multiplication sum. Any PZN number, whose check digit would be 10 is not handed out.

**Example**

123456



Check digit:  $2+6+12+20+30+42 = 112 / 11 = 10 \text{ Rest } 2$   
<14><27>)0Y<27>)sp4.6h12vsbT\*-123456\*<15>



## CODE-39 extended

The **usage** and **calculation** of the optional **check digit** is identical to the code 39. Even the range of valid characters are the same.

In addition the full **US-ASCII** table can be coded by setting in front of every character an additional control character: \$, %, / or +.

ASCII	39 ext	ASCII	39 ext	ASCII	39 ext	ASCII	39 ext
NUL	%U	DC2	\$R	\$	/D	?	%J
SOH	\$A	DC3	\$S	%	/E	@,\$	%V
STX	\$B	DC4	\$T	&	/F	A..Z	A-Z
ETX	\$C	NAK	\$U	'	/G	[,Ä	%K
EOT	\$D	SYN	\$V	(	/H	\,Ö	%L
ENQ	\$E	ETB	\$W	)	/I	] ,Û	%M
ACK	\$F	CAN	\$X	*	/J	^	%N
BEL	\$G	EM	\$Y	+	/K	¯	%O
BS	\$H	SUB	\$Z	,	/L	˘	%W
HT	\$I	ESC	%A	-	/M	a..z	+A .. +Z
LF	\$J	FS	%B	.	/N	{,ä	%P
VT	\$K	GS	%C	/	/O	\,ö	%Q
FF	\$L	RS	%D	0..9	0..9	},ü	%R
CR	\$M	US	%E	:	/Z	~,ß	%S
So	\$N	SP	space	;	%F	DEL	%T
SI	\$O	!	/A	<	%G		
DLE	\$P	„	/B	=	%H		
DC1	\$Q	#	/C	>	%I		

**NOTE** To recognize the Codes 39 extended, your reader usually must be set to this code. Otherwise it may return the control signs as pure message information.

### Example

h-p proportion 1:3 no check digit



<14><27>)10Q<27>)s1p12vsb10001T\*+H/M+P\*<15>

---

## CODE-93

### ESC-Sequences

<27>(10Q<27>(s1p###v0s0b10250T           no readable text  
<27>(10Q<27>(s1p###v0s0b10251T           readable text  
### Font size in point

### Valid characters

Numbers 01..89, upper case characters A-Z, special signs \$%+-. / space @ <64>.

### Usage

The start bar, opening parenthesis ‘(’, is followed by message, two check digits and the stop bar, closing parenthesis ‘)’.

### Check digits

The Code 93 needs 2 check digits. The first one is calculated out of the sum of the multiplication from right to left of each reference value with its position number. After each 20th position, the multiplication factor is reset to 1. Finally the reference value of the first check digit is calculated out of the sum by **modulo 47**.

The second check digit follows the same algorithm. The first check digit is already multiplied with position 1, and the multiplication factor is reset after each 15th character to 1.

The reference values of the message characters are:

Val.	Ref.	Val.	Ref.	Val.	Ref.	Value	Ref.	Value	Ref.
0	0	A	10	K	20	U	30	/	40
1	1	B	11	L	21	V	31	+	41
2	2	C	12	M	22	W	32	%	42
3	3	D	13	N	23	X	33		
4	4	E	14	O	24	Y	34		
5	5	F	15	P	25	Z	35		
6	6	G	16	Q	26	-	36	a	43
7	7	H	17	R	27	.	37	b	44
8	8	I	18	S	28	Space	38	l	45
9	9	J	19	T	29	\$	39	h	46

---

Example for character calculation: CODE 93

1. Example:

$$3 + 2*9 + 3*38 + 4*14 + 5*13 + 6*24 + 7*12 = 484$$

484 Modulo 47 = 10 rest 14 => ASCII E

2. Example:

$$14 + 2*3 + 3*9 + 4*38 + 5*14 + 6*13 + 7*24 + 8*12 = 611$$

611 Modulo 47 = 13 rest 0 => ASCII 0

**Example**

CODE 93



<14><27>)10Q<27>)s1p12vsb10251T(CODE@93E0)<15>

---

## CODE-93 extended

### ESC-Sequences

Identical to code 93.

### Valid characters

Identical to code 93, additional control characters 'a', 'b', 'h' and 'l'.

### Usage

In order to handle with the same valid characters like Code 93 the full ASCII character set there is a two byte coding necessary. In front of each character there must be printed on of the following control characters 'a', 'b', 'h' or 'l':

Val.	Codi.	Val.	Codi.	Val.	Coding	Val.	Coding
NUL	bU	DC2	aR	\$	ID	?	bJ
SOH	aA	DC3	aS	%	IE	@,\$	bV
STX	aB	DC4	aT	&	IF	A..Z	A-Z
ETX	aC	NAK	aU	'	IG	[,Ä	bK
EOT	aD	SYN	aV	(	IH	\,Ö	bL
ENQ	aE	ETB	aW	)	II	]„Ü	bM
ACK	aF	CAN	aX	*	IJ	^	bN
BEL	aG	EM	aY	+	IK or +	¯	bO
BS	aH	SUB	aZ	,	IL	˘	bW
HT	aI	ESC	bA	-	IM oder -	a..z	hA .. hZ
LF	aJ	FS	bB	.	IN or .	{,ä	bP
VT	aK	GS	bC	/	IO od /	\,ö	bQ
FF	aL	RS	bD	0..9	IP..IY or 0.9	},ü	bR
CR	aM	US	bE	:	LZ	~,ß	bS
So	aN	SP	space	;	bF	DEL	bT
SI	aO	!	lA	<	bG		
DLE	aP	„	lB	=	bH		
DC1	aQ	#	lC	>	bI		

### Example

Code 93   
<14><27>)10Q<27>)s1p12vsb10251T(ChOhDhE@93a8)<15>

---

## Codabar

### ESC-Sequences

<27>(10Q<27>(s1p###vsb10002T      no readable text  
<27>(10Q<27>(s1p###vsb15007T      readable text  
### Font size in point

### Valid characters

01..89 \$ + - . / :

### Usage

According to the application, the Start-/Stop signs can be used out of the following character range: 'A', 'B', 'C' or 'D'.

### Example

6789012   
<14><27>)10Q<27>)s1p20vsb15007TA6789012B<15>

## AIM Codabar

The AIM codabar does need an additional check digit in front of the stop bar.

### Check digit

The numbers 0-9 do get the **reference value** 0-9, minus 10, dollar sign 11, colon 12, slash 13, point 14, plus sign 15 and start- stop signs A-D 16-19.

The check number is calculated through the addition of the reference values of all bars, including start and stop. The final number is the difference to the next 16th multiplier.

Example:	Message information	A01234B
	Sum of the reference values	16+0+1+2+3+4+17 = 43
	check digit algorithm	3 * 16 = 48 - 43 = 5
	printing information	A012345B

Further information is available at AIM USA, 634 Alpha Drive, Pittsburgh, PA 15238-2802, USA, phone (412) 963-8588, fax (412) 963-8753.

---

## 2of5 interleaved

**ESC-Sequences** (not supported in Color LJ 8500 and 8550)

<27>(10Q<27>(s1p###v0s0b13000T	no readable text	V1:3
<27>(10Q<27>(s1p###v0s0b13100T	no readable text	V1:3
<27>(10Q<27>(s1p###v0s0b13001T	readable text	V1:3
<27>(10Q<27>(s1p###v0s*b13020T	no readable text	V1:2.5
<27>(10Q<27>(s1p###v0s0b13011T	readable text	V1:2.5
<27>(10Q<27>(s1p###v0s*b13010T	no readable text	V1:2
<27>(10Q<27>(s1p###v0s0b13011T	readable text	V1:2

### Font size in point

\* 0->3 different Height/Width relations.

### Valid characters

Numeric numbers 0-9

### Usage

Using the interleaving method for printing digits, the code is very compact. Therefore always two digits are coded at a time. The first digit is represented by the bar lines, the second by the spaces.

Start sign '#', stop sign '\$'

The number of message characters including optional check digit is always even. In order to print the code 2of5 interleaved you have to add a small calculation routine to your application. Each pair of numbers is printed directly as one character using this is the algorithm:

$$\text{Value first digit} * 10 + \text{Value second digit} + 40.$$

**Examples:** Number 12 results in  $1*10+2+40 = 52 = \text{number '4'}$   
Number 57 results in  $5*10+7+40 = 97 = \text{character 'a'}$

### Check digit (optional)

Sum all values of the odd positioned digits beginning with position 1. Multiply the result by 3 and add the values of the even digits.

The check digit is calculated out of the subtraction to the next by 10 dividable number (modulo).

Example: message information 1632534 needs check digit 0  
 $(1+3+5+4) * 3 + 6 + 2 + 3 = 50 + 0 = 50$

---

## Notes

The utility disk contains detailed **examples** including some **C source** code for printing code 2of5 interleaved. The following C code shows the minimum routine:

```
void Barcode2of5interl(int Value)
{
    char ValStr[50];
    int i = 0;
    printf(„%c(10Q%c(s1p12vsb13001T#“, 27, 27);
    itoa(Value, ValStr, 10);
    while(i < strlen(ValStr)
    {
        char PrintCh=(ValStr[i]-‘0‘)*10 + (ValStr[i+1]-‘0‘)+40;
        /* PrintChar += 72; */      /* see below */
        printf(„%c“, PrintCh);
        i = i + 2;
    }
    printf(„$“);
}
```

Some Computer Systems as e.g. AS/400 have problems to send characters above ASCII 128. The fonts with the additional name HOST, type face number 13050, 13051 (1:3); 13150 (1:3 Post) and 13052 (1:2) do print all characters starting position 91, but moved down to starting position 41.

The characters above 127 are also again implemented at position 200 and above within the same master fonts.

You may switch using Shift-In and Out between both fonts.

## Examples

123456 readable text without check digit (even)

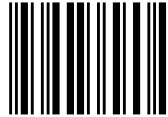

<14><27>)10Q<27>)s1p10vsb13001T#<52><84><96>\$<15>

324690 readable text without check digit (even message characters)

<27>(10Q<27>(s1p10vsb13001T#<72><86><130>\$

32469085 readable text without check digit, using „host“ fonts

<27>(10Q<27>(s1p10vsb13000T<27>)10Q  
<27>)s1p10vsb13050T#<72><86><14><80><75><15>\$

---

## German Post AG

This code is based upon the 2of5 interleaved and therefore not implemented on the sos8026C product. For differentiation to this code on the packaging materials, the German Post do calculate the check digit in a slightly different way.

### ESC-Sequence

<27>(10Q<27>(s1p16.5v0s3b13020T V1:2.5  
<27>(10Q<27>(s1p72v0s0b13100T V1:2

### Usage

The detailed information of how to use this code is available from German Post AG in Marburg.

The „Leitcode“ does represent 13 message digits:

digits 1-5	=	Zip code
digits 6-8	=	Reference number of the street
digits 9-11	=	House number
digits 12-13	=	Product code
digit 14	=	check digit

The „Identcode“ needs 11 message digits:

digits 1-2	=	First distribution center number
digits 3-5	=	customer number
digits 6-11	=	mailing number
digit 12	=	check digit

The line with readable text has to be compiled by the software.

### Check digit

The calculation uses the same algorithm as the standard 2of5 interleaved code, but the odd numbers (remember from right to left) are multiplied by 4 and the even numbers by 9.

1234567890123:

$$(1+3+5+7+9+1+3)*4 + (2+4+6+8+0+2)*9 = 014+1 = 020$$

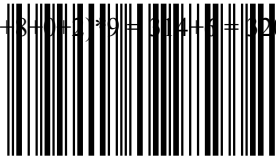

### Example

1324354657687 check digit 1

<14><27>)10Q<27>)s1p72vsb13100T#5@KValy\$<15>



---

## 2of5 industrial

### ESC-Sequences

<27>(10Q<27>(s1p###v0s0b12004T	no readable text
<27>(10Q<27>(s1p###v0s0b12005T	readable text

### Font size in point

### Valid characters

Numeric numbers 0..9

### Usage

The start bar is coded on character 'A' or 'a', the stop bar 'B' or 'b'.  
The message length is unlimited.

### Check digit (Optional)

The check digit calculation uses the same algorithm as code 2aus5 interleaved, **modulo 10** with multiplier 3. The even/odd multiplier is calculated from right to left. This direction is also given for the 2of5 interleaved, but is there because of the always even number of message digits not necessary.

Example 789012 results in 7890123  
 $(2+0+8) * 3 + 1 + 9 + 7 = 47 + 3 = 50$

### Example

6789012 <14><27>)10Q<27>)s1p20vsb12005TA6789012B<15>

## 2of5 matrix

### ESC-Sequences

<27>(10Q<27>(s1p###vsb10500T	no readable text
<27>(10Q<27>(s1p###vsb10501T	readable text

### Font size in point

### Valid characters and Usage

See 2of5 industrial.

### Example

6789012 <14><27>)10Q<27>)s1p20vsb10500TA6789012B<15>

---

## EAN 13

### ESC-Sequences

<27>(10Q<27>(s1p###v0s\*b10100T

no readable text

<27>(10Q<27>(s1p###v0s0b10101T

readable text

### Font size in point

\* 0->3 different Height/Width relations.

### Valid characters

Numbers 0..9 are coded on the following 4 positions: 0..9, P..Y, p..y and as text A..J. The start-stop-middle-signs are 'b', 'e' and 'm' or 'g', 'f' and 'm'.

### Usage

The code contains always one start code (**begin/g**), 6 numbers, middle sign (**middle/n**), 5 numbers, check digit and one end bar (**end/f**). If you use 'bme' then the code will look like fully embedded, 'gnf' half embedded.

EAN does code the numbers 0..9 three times, depending of the printing position. The printed number in front of the code do represent the first message digit, usually the country code. Use text printing pool A..J.

The 6 numbers after the middle sign are always taken out of number pool 2. The 6 numbers before the middle sign do represent the message numbers 2 to 7. Depending upon the first message digit, they are taken out of the number pool 0 or 1. This coding mechanism enables the reader to recalculate the first digit.

<i>First digit</i>	<i>Pos 1</i>	<i>Pos 2</i>	<i>Pos 3</i>	<i>Pos 4</i>	<i>Pos 5</i>	<i>Pos 6</i>
<b>1</b>	0	0	1	0	1	1
<b>2</b>	0	0	1	1	0	1
<b>3</b>	0	0	1	1	1	0
<b>4</b>	0	1	0	0	1	1
<b>5</b>	0	1	1	0	0	1
<b>6</b>	0	1	1	1	0	0
<b>7</b>	0	1	0	1	0	1
<b>8</b>	0	1	0	1	1	0
<b>9</b>	0	1	1	0	1	0
<b>0</b>	0	0	0	0	0	0

The pool **0** is represented by the numbers 0..9. Decimal 48 to 57

The pool **1** is represented from P..Y. Dec. 80 to 89 (Value+32)

The pool **2** is represented from p..y. Dec. 112 to 121(Value+64)

---

EAN 13 do code 12 message digits, but only the right eleven are printed.

For German products, country code 4 (represented by character 'E'), the digits come out of the following pools: Eb010011m222222e.

### Check digit

Add all even positioned numbers, multiply the result by 3 and add all odd numbers. The check digit is calculated out of the subtraction to the next by 10 dividable number (modulo).

Example: 009623900115, check digit = 4  
 $(0+6+3+0+1+5)*3 + (0+9+2+9+0+1) = 66 + 4 = 70$

### Example

401234598765 check digit: 2  4 012345 987652  
<27>(10Q<27>(s1p30vsb10101TEg0Q23TUnyxwvurf

## EAN 8

ESC-Sequences, valid characters and check digit is according to EAN 13.

### Usage

The code construction is one start code (**begin/g**), 4 numbers, middle sign (**middle/n**), 3 numbers, check digit and one end sign (**end/f**).

The numbers 0..9 are, compared to EAN 13, only coded in two pools. Depending on the print position, they have to be taken according to the following positioning table b0000m2222e.

The pool **0** are the numbers 0..9 themselves, Decimal 48 to 57  
The pool **2** are characters p..y, Decimal 112 to 121 (Value+64)

### Example

4018273 results in check digit 5  4018 2735  
<14><27>)10Q<27>)s1p30vsb10101Tg4018nrwsuf<15>

---

## **EAN 10mil of „Bar Codes & More“**

### **ESC-Sequence**

<27>(8Y<27>(s1p12v0s0b0T

### **Valid characters**

start bar ‘(’, middle sign ‘-’, stop bar ‘(’, number pools: 0..9, A..J, a..j

### **Usage**

See EAN 13 scaleable, but the numbers are coded in different pools.

The number pool **0** is represented by the numbers 0..9. Dec. 48 to 57

The number pool **1** is represented from a..j. Dec. 97 to 107

The number pool **2** is represented from A..J. Dec. 112 to 121

### **Example**

001234567890

<14><27>)8Y<27>)s1p12vsbT(012345-GHIJAF(<15>

## **EAN 13mil from „Bar Codes & More“**

### **ESC-Sequence**

<27>(8Y<27>(s1p12v0s3b0T

**Valid characters** and **Usage** see 10mil.

## **EAN-Velocity**

### **Usage**

This code is similar to EAN 8, but first digit is always 0.

## **EAN 128**

**Usage** (not supported in Color LJ 8500 and 8550)

This code is identical to the code 128. The control bar FC1 must be printed direct after the start bar. The check digit calculation starts with FC1 at position 1. The first message character will be multiplied with position 2.

The maximum amount of message characters is limited to 48, however, the maximum amount of printed characters is 35. This limitation includes start-, stop- and control bars.

---

## UPC-A

**ESC-Sequence** see EAN-13

### Usage

This code is quite similar to EAN-13, the first digit is always set to 0 and is not sent to the printer. The first 6 digits are coded out of the pool **0** and the remaining 5+1 digits after the middle sign from pool **2**. The coding of the first digit is not used. The pool positions are: b000000m222222e

### Check digit

Multiply the sum of all odd positioned digits with 3 and add the remaining digits. The check digit is the value to add in order to reach the next fully by 10 dividable number.

Example: 12131415161, Check digit = 2  
 $(1+1+1+1+1+1)*3 + (2 + 3 + 4 + 5 + 6) = 38 + 2 = 40$

### Readable text

The following rules apply to print the codes including readable text:

1. The first sign is printed as text in front of the code, pool (A..J)
2. The check digit is printed as text direct after the stop sign, using pool (A..J)
3. The code information of the first digit and the check sum are printed in the same length as the start-, stop- and middle signs.

In order to do this, you have to switch between the fonts for non and readable text.

### Example

12345678901 Check digit 2  
<27>(10Q<27>(s1p70vsb10101T Initialize readable text as primary font  
<27>)10Q<27>)s1p70vsb10100T Initialize non readable text as secondary  
font  
B<14>b1<15>23456mwxypq<14>re<15>C

---

## UPC-E

**ESC-Sequence** see EAN-13

### Valid characters

Start bar 'b', Stop bar 'a', 0..9, A..J

### Usage

This codes does represent 7 digits. The first one can be either 0 or 1 and defines the final encoding: E0 or E1.

The remaining 6 digits are coded depending upon the check digit. The pool **0** corresponds to (0..9) and **1** (P..Y).

CD	Coding E0						Coding E1					
	P2	P3	P4	P5	P6	P7	P2	P3	P4	P5	P6	P7
<b>1</b>	1	1	0	1	0	0	0	0	1	0	1	1
<b>2</b>	1	1	0	0	1	0	0	0	1	1	0	1
<b>3</b>	1	1	0	0	0	1	0	0	1	1	1	0
<b>4</b>	1	0	1	1	0	0	0	1	0	0	1	1
<b>5</b>	1	0	0	1	1	0	0	1	1	0	0	1
<b>6</b>	1	0	0	0	1	1	0	1	1	1	0	0
<b>7</b>	1	0	1	0	1	0	0	1	0	1	0	1
<b>8</b>	1	0	1	0	0	1	0	1	0	1	1	0
<b>9</b>	1	0	0	1	0	1	0	1	1	0	1	0
<b>0</b>	1	1	1	0	0	0	0	0	0	1	1	1

### Check digit

In order to calculate the check digit, the barcode number has to be enlarged by some additional digits at various positions. The enlargement is in strict relation to the last digit. The table below illustrates the method:

Last digit x	Enlargement	Example 12345x
0	##0000###	1200000345
1	##1000###	1210000345
2	##2000###	1210000345
3	###00000##	1230000045
4	####00000#	1234000005
5..9	#####0000x	123450000x x = 5..9

---

The needed check sum is calculated as described in UPC-A.

Example: E1 789012 -> 17820000901 -> Check digit = 4  
(1+8+0+0+9+1) \* 3 + (7+2+0+0+0) = 66 + 4 = 70

### Readable text

The „coding digit“ is set in front and the check digit after the stop bar.

### Example

0876548 Check digit 2  
<14>AbXW65T8aC<15>



## EAN / UPC Addon 2

**ESC-Sequence** see EAN-13

### Valid characters

Start bar 'c', middle bar 'd', <33>..<<42>, <130>..<<139>

### Usage

To be able to verify the 2 digits, they are taken out of two different pools. The pool **0** is coded <33>..<<42> and **1** <130>..<<139>. The pool usage is calculated of the remaining value of the division of the printing information by 4

Remain value	Pool for 1. digit	Pool for 2. digit
0	0	0
1	0	1
2	1	0
3	1	1

The final coding is: c#d#, where # stands for the number coming out of the various pools.

### Examples

40	<14>c%d!<15>	01	<14>c!d<131><15>
10	<14>c<131>d!<15>	03	<14>c<131>!<133><15>

---

## EAN / UPC Addon 5

ESC-Sequence see EAN-13

### Valid signs

Start bar 'c', sign separator 'd', <33>..<<42>, <130>..<<139>

### Usage

The start bar is followed by the usage digit. The separator sign has to be inserted between each digit. Similar to 2 the digits are taken out of pool **0** <33>..<<42> and **1** <130>..<<139>. The variation of the pools is calculated out of an unprinted check sum.

CD	P1	P2	P3	P4	P5
1	1	0	1	0	0
2	1	0	0	1	0
3	1	0	0	0	1
4	0	1	1	0	0
5	0	0	1	1	0
6	0	0	0	1	1
7	0	1	0	1	0
8	0	1	0	0	1
9	0	0	1	0	1
0	1	1	0	0	0

This results into the following coding advise: c#d#d#d#d#. The sign # is the user digits coming out of the via check digit calculated pools.

### Check digit

All even positioned digits are added and has to be multiplied by 3. The sum of the remaining digits has to be multiplied by 9. Add both results. The check digit is the remaining value of the division by 10.

Example: 20617 Check digit = 9  
 $(2 + 6 + 7) * 3 + (0 + 1) * 9 = 54$

### Example

20617 <14>c<35>d<130>d<136>d<34>d<40><15>





---

## MSI

### Esc-Sequences

<27>(10Q<27>(s1p###v0s0b10750T	without readable text
<27>(10Q<27>(s1p###v0s0b10751T	with readable text

### size in point

### Valid signs

numbers 01..89

### Usage

The start bar 'A' is followed by the user digits, the check sign(s) and the stop bar 'B'. The maximum length is 13 digits.

If you use readable test and Start- Stop bar 'A' and 'B' the readable text looks like embedded. Using 'a' and 'b' will print the readable text below the bars.

The calculation of the check signe is optional.

### Check digit mode 1

In order to calculate the check digit generate first a new number of all even positioned digits, beginning from right hand side. Then double the number. Sum all digits from the new number and the remaining digits. The check digit results out of the difference to the next full by 10 dividable number.

Example:

Coding information	987654
New number of odd positions from right	864
Multiply by 2	1728
Add	$1+7+2+8 = 18$
Add remaining coding digits	$18+9+7+5 = 39$
Check digit	$40 - 39 = 1$

### Check digit mode 2

For the two digit check sum calculate the first digit like mode 1. This first digit will be now the last number of the new coding information. Just redo the calculation according mode 1.

---

### Check digit mode 3

For the first digit multiply all digits by their position. Go from right to left. The multiplication factor starts with 2 and is again set to 2 after the 8<sup>th</sup> position. The check digit is calculated from 11 minus the remaining value of the factor sum divided by 11.

The second check digit has to be calculated like mode 1.

Example: 612345

Factor sum:  $5*2 + 4*3 + 3*4 + 2*5 + 1*6 + 6*7 = 92$

Modulo 11  $92 \text{ Modulo } 11 = 9 \text{ Rest } 4$

First check digit  $11 - 4 = 7$

Second check digit according mode 1: 1

### Examples

98765	no Check digit		<14>A98765B<15>
012345	CD Modus 1	CD: 5	<14>A0123455B<15>
012345	CD Modus 1	CD: 5	<14>A0123455B<15>
712345	CD Modus 2	CD1: 8 CD2: 7	<14>A71234587B<15>
612345	PZ Modus 3	CD1: 7 CD2: 1	<14>A61234571B<15>

### USPS ZIP of „Bar Codes & More“

This code is exclusively used by the US post offices. On any business letter and post card there can be printed beside the stamp the FIM sign and at the bottom of the envelope the UPSZIP code.

### ESC-Sequence

<27>(15Y<27>(s1p12vsbT

### Valid characters

# - 0..9 <124> FIM signs: A..D Start-Stop: \*

### Usage

The usage is very detailed explained in the publication „A Guide to Business Mail Preparation“. This booklet is available at any US post office.

### Example

8370799340 <14><27>)15Y<27>)s1p12vsbT\*8370799340\*<15>

---

## CODE 128

**ESC-Sequence** (not supported in Color LJ 8500 and 8550)

<27>(10Q<27>(s1p##vsb11000T

### Font size in point

### Valid characters

The code does realize in total 107 characters. The complete US-ASCII table is coded beside the necessary control signs. This code do work within three different modes:

CODE A, B and C. Depending of the used control signs, each bar do represent one of the following three contents:

Ref.	A	B	C	Ref.	A	B	C	Ref.	A	B	C
0	SP	SP	00	27	:	:	27	55	W	W	55
1	!	!	01	28	<	<	28	56	X	X	56
2	”	”	02	29	=	=	29	57	Y	Y	57
3	#	#	03	30	>	>	30	58	Z	Z	58
4	\$	\$	04	31	?	?	31	59	Ä,[	Ä,[	59
5	%	%	05	32	§,@	§,@	32	60	Ö,\	Ö,\	60
6	&	&	06	33	A	A	33	61	Ü,]	Ü,]	61
7	‘	‘	07	34	B	B	34	62	^	^	62
8	(	(	08	35	C	C	35	63			63
9	)	)	09	36	D	D	36	64	NUL	`	64
10	*	*	10	37	E	E	37	65	SOH	a	65
11	+	+	11	38	F	F	38	66	STX	b	66
12	,	,	12	39	G	G	39	67	ETX	c	67
13	-	-	13	40	H	H	40	68	EOT	d	68
14	.	.	14	41	I	I	41	69	ENQ	e	69
15	/	/	15	42	J	J	42	70	ACK	f	70
16	0	0	16	43	K	K	43	71	BEL	g	71
17	1	1	17	44	L	L	44	72	BS	h	72
18	2	2	18	45	M	M	45	73	HT	i	73
19	3	3	19	46	N	N	46	74	LF	j	74
20	4	4	20	47	O	O	47	75	VT	k	75
21	5	5	21	48	P	P	48	76	FF	l	76
22	6	6	22	49	Q	Q	49	77	CR	m	77
23	7	7	23	50	R	R	50	78	SO	n	78
24	8	8	24	51	S	S	51	79	SI	o	79
25	9	9	25	52	T	T	52	80	DLE	p	80
26	:	:	26	53	U	U	53	81	DC1	q	81
27	;	;	27	54	V	V	54	82	DC2	r	82

Ref	A	B	C	Ref	A	B	C	Ref	A	B	C
83	DC3	s	83	91	ESC	ä,{	91	99	Co C	Co C	99
84	DC4	t	84	92	FS	ö,	92	100	Co B	FC4	Co B
85	NAK	u	85	93	GS	ü,}	93	101	FC4	Co A	Co A
86	SYN	v	86	94	RS	ß	94	102	FC1	FC1	FC1
87	ETB	w	87	95	US	DEL	95	103	Start	Code	A
88	CAN	x	88	96	FC3	FC3	96	104	Start	Code	B
89	EM	y	89	97	FC2	FC2	97	105	Start	Code	C
90	SUB	z	90	98	Shift	Shift	98	106	Stopp		

### Usage

The code consist of minimum 4 units: start bar, message, check digit and the stop bar.

The start bar defines the code mode (A/B/C or Reference 103 to 105), in which the following data begin to be coded.

With the usage of additional **control signs** it is possible to change the mode within the message data. (Reference 100 to 102).

For code 128 the **characters to print** are calculated by adding 33 to the reference value. This makes it easy for code A and B, just add 1 to the ASCII-value of the message sign.

**Examples:** Code A character 'C' is printed as <68> = 'D'  
Code B character 'c' is printed as <100> = 'd'  
Code C number combination 99 is printed as <132>

Some Computer Systems as e.g. AS/400 have problems to send characters above ASCII 128. The fonts with the additional name HOST, type face number 11050 and 11051 do print all characters starting position 91, but moved down to starting position 41.

You may switch using Shift-In and Out between both fonts. Some examples are explained at chapter 2of5 interleaved.

The characters above 127 are also again implemented at position 200 and above within the same master fonts.

---

### Check digit

The check digit is the **modulo 103** result of the addition of all reference values multiplied with their position.

Example: CODE 128:

Message	St.B	C	O	D	E	space	1	2	8
Reference value	104	35	47	36	37	0	17	18	24
Multiplicator	1	1	2	3	4	5	6	7	8
Sum	104	+ 35	+ 94	+ 108	+ 148	+ 0	+ 102	+ 126	+ 192
Check digit	= 909 Module 103 = 85 (reference digit)								

### Example 1

Using CODE B to print: CODE 128



Message	St.B	C	O	D	E	space	1	2	8	check	end
Reference.	104	35	47	36	37	0	17	18	24	85	106
Print char.	137	68	80	69	70	33	50	51	57	118	139

The calculation of the check digit is shown in the above example.

### Example 2

The message is: 1234Abc. The numbers are printed in compression mode C, the characters in mode B:

The check digit: 1349 modulo 103 = reference 10.

Message	St.C	12	34	C B	A	b	c	check	end
Reference	105	12	34	100	33	66	67	10	106
Multiplicator	1	1	2	3	4	5	6		
Check digit	105	12	68	300	132	330	402		
Print char.	138	45	67	133	66	99	100	43	139

---

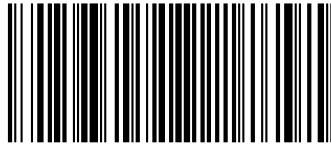
**Example 3: UPS Barcode**

Message: 1Z645413530102336

Message	Reference	Print char.	UPS check digit	Code 128 check
Start B	104	137		104
1	17	50		17 * 1 = 17
Z	58	91		58 * 2 = 116
6	22	55	6	22 * 3 = 66
4	20	53	+ 8	20 * 4 = 80
5	21	54	+ 5	21 * 5 = 105
4	20	53	+ 8	20 * 6 = 120
1	17	50	+ 1	17 * 7 = 119
3	19	52	+ 6	19 * 8 = 152
Co C	99	132		99 * 9 = 891
53	53	86	+ 5 + 6	53 * 10 = 530
01	01	34	+ 0 + 2	1 * 11 = 11
02	02	35	+ 0 + 4	2 * 12 = 24
33	33	66	+ 3 + 6	33 * 13 = 429
64	64	97	+ 6 = 66 -> 4	64 * 14 = 896
55	55	88		
Stop	106	139		

Code 128 check digit:  $3660 \text{ modulo } 103 = 35 \text{ Rest } 55$ 

The detailed description of the code is available at any UPS office.

Position 1-2 = FACT control ("1Z")  
Position 3-8 = UPS customer number  
Position 9-10 = Service code  
Position 11-17 = shipment number  
Position 18 = check sum

Service code: 53 = Standard collection, 54 = Express plus  
55 = Express, 56 = Standard.

---

## **UPC-128**

The code 128 UPC Shipping Container is a numeric version of code 128 C with the fixed length of 10 digits. In addition to the regular modulo 103 check digit the code is enhanced with a module 10 check digit.

This results in the following structure:

Start C, FNC 1, [19 digits of numeric data], m10 check digit, modulo 103 check digit, Stop bar.

### **Modulo 10 check digit**

All odd positioned digits are multiplied by 3 and the result is summed with the even positioned digits. The check digit is calculated by 10 minus sum modulo 10.

### **Example**

0223456789123456789

UCC check digit: 9,  
Code 128 check digit 41

---

## CMC 7 Font

### ESC-Sequence

<27>(\_<27>(s1p##vs3b10453T

\_\_\_\_\_ any symbol set, see User Reference Manual

### Font size in point

### Valid characters

01..89 0 1 2 3 4 5 6 7 8 9  
: ; < = >

### Usage

This font is used in some countries for check printing.

### Example

<27>(10U<27>(s1p12vs3b10453T<1972675>0013< 0267> 0100027073;

197267540013 0267 0100027073

### Important Note

This font was carefully developed, but it is not certified by the test authority. For certified fonts please replace this product with the JetCAPS MICR SIMM/DIMM.



---

## **MICR Font**

### **ESC-Sequence**

<27>(\_<27>(s1p##vsb10453T

\_\_\_\_\_ any symbol set, see User Reference Manual

### Font size in point

### **Valid characters**

01..89 0 1 2 3 4 5 6 7 8 9

A A B B C X D Δ

### **Usage**

This font was carefully developed, but it is not certified by the test authority. For certified fonts and a even much more secure implementation, please have a closer look to the JetCAPS MicrSIMM/ DIMM.

---

## KIX Code

The KIX Barcode is used by the Netherlands post office. Please have a look in the KIX subdirectory of the sos8026 utility disk. For addressing the font, see next Barcode

### Singapore 4state KIX Code

#### ESC-Sequence

<27>(15Y<27>(slp14.4vsb

#### Valid signs

numbers 01..89 and AB..YZ, start-sign ‘(’, stop-sign ‘)’

#### Usage

The start bar ‘(’ is followed by the user digits, the check sign and the stop bar ‘)’.

#### Check sum calculation

For all user characters of the code, calculate the Ascender sum. Then divide it by six and keep the remainder for the new Ascender Check sum.

Proceed the same calculation method with the Descender.

The check digit is the crossing of the Ascender and Descender remainders.

		Descender Value					
		1	2	3	4	5	0
Ascender Value	1	0	1	2	3	4	5
	2	6	7	8	9	A	B
	3	C	D	E	F	G	H
	4	I	J	K	L	M	N
	5	O	P	Q	R	S	T
	0	U	V	W	X	Y	Z

#### Example:

For the postal code “122346”:

A) Ascender Sum =  $(1+1+1+1+1+2) = 7 \% 6 = 1$  Remainder 1

B) Descender Sum =  $(2+3+3+4+5+1) = 18 \% 6 = 3$  Remainder 0

The check sum = 5

---

## **Addresses**

Further written information for bar-coding could be requested at the following addresses:

- AIM: AIM USA, 634 Alpha Drive, Pittsburgh, PA 15238-2802, (412) 963-8588.
- Code 39: (ANSI MH10.8-1983, Chapter 4.4) American National Standards Institute (ANSI), Sales Dept., 1430 Broadway, NY, NY 10018, (212) 642-4900
- EAN: EAN International, Rue de Colonies 54, BTE 8, 1000 Bruxelles, Belgium, (02) 2187675
- JAN: Japan Industrial Standard Organization, The Distribution Code Center, No. 2 TOC-Bldg 7-23-1, Nishigotanda, Shinagawa-ku, Tokyo 141
- UPC: Uniform Product Code Council, Inc., 7051 Corporate Way, Suite 201, Dayton, OH 45459-4294, (513) 435-3870.

---

## Macro (Form)

The sos8026 Version 1.1 and higher contains a macro or form. Printing this macro will result in sos8026 version statement.

Storing forms as macros into a printer will provide the following benefits:

- Significant reduction of data stream
- Faster printout of documents
- Security of „unchangeable“ forms
- Separation from data and form. This will prevent of reprinting old data on old forms, e.g. letters heads.

The utility disk provides the following test files for evaluation:

- VERSION.TXT (ASCII Format)
- WINWORD\FORMULAR.DOC

The macro is called through the following printer ESC-Sequence:

<27>&fs100y3x1S

Generally every application software is able to use automatic overlaid forms. There any PCL driver is needed. For SAP just define a new print control and call it an ABAB or SAPScript.

---

Note	The application will still have to position the variable data as it is doing right now.
------	---

---

For the implementation of additional fonts, forms or logos, you may choose out of the following methods:

1. Purchasing the sos8036 fonts as soft fonts in conjunction with an HP Flash SIMM (Euroform!).
2. Send any PCL print file on floppy to stethos Systemhaus GmbH® or one of the distribution addresses, listed on the next pages. For an additional fee we can implement your customization into the standard product.

## VDA 4902 form

This form is added in its third edition and is movable. The macro number 300 activates the form. The top left corner is printed at the actual cursor position. In order to print 2 forms on a A4 page in portrait, you need the following ESC-Sequences:

<27>&l1E	Definition of top margin at column 1.
<27>&a0h0V	Set printer cursor top left
<27>&fs300y3x1S	Call macros 300
<27>&a0h4100V	Set cursor down to the lower half of page
<27>&fs300y3x1S	Call macro 300

English: Macro 301, French: Macro 302, Italien: Macro 303  
 Spanish: Makro 304, Version 4: English: Macro 311, German: Macro 312

A complete print sample is stored on the utility disk at VDA4902.TXT.

You will find the safety symbol  described on page 20. The barcodes are generated with 3of9 V1:2.5: <27>(10Q<27>(s1p17vs1b10006T.

The space signs in the field Sach-Nummer have to be printed using the ,@' sign. If this conversion is cannot be made, you do need the JetCAPS BarSIMM!

(1) Warenempfänger stethos Systemhaus GmbH Weimarer Strasse 48 71065 Sindelfingen		(2) Abladestelle - Lagerort - Verwendungsschlüssel <b>4711</b>	
(3) Lieferschein-Nr. (N) <b>1234567</b> 		(4) Lieferantenanschrift (Kurzname, Werk, PLZ, Ort) stethos Systemhaus GmbH Weimarer Strasse 48, 71065 Sindelfingen	
		(5) Gewicht netto 1000,5	(6) Gewicht brutto 1010.8
		(7) Anzahl Packstücke 12	
(8) Sach-Nr. Kunde (P) <b>X 123 456 78 90</b> 			
(9) Füllmenge (C) <b>XY STÜCK</b> 		(10) Bezeichnung Lieferung, Leistung sos8026s HP OCR+BARCODE	
(12) Lieferanten-Nr. (V) 123-12345 		(11) Sach-Nr. Lieferant (308) <b>ABC01 2345 DE5F</b>	
		(13) Datum 25.01.98	(14) Änderungsstand Konstruktion
(16) Packungs-Nr. (8) 12345-1 		(15) Chargen-Nr. (H)	
(17) Warenanhänger VDA 4902, Version 3, stethos Systemhaus GmbH			

---

## **sos8026 and SAP R/2 and R/3**

### **OCR-A1 and OCR-B**

For both fonts the sos8026 module is fully compatible to the JetCAPS BarSIMM/DIMM and the Barcode & More cartridge, which are SAP certified. SAP supplies those PRINT-Controls in the HP LaserJet printer driver:

OCR-A          SF400                                  OCR-B          SF500

### **Barcodes**

Because of the reasons, which are already explained on page 13, most barcodes of the sos8026 module are not able to be used from SAP applications. However, the following barcodes can be used:

Code 3of9                                  Codabar                                  Code 2of5 matrix  
Code 2of5 industrial  
Code 2of5 interleaved (See on utility disk, directory SAP)

You need to define your own print controls for selection and de-selection. The selection sequence must end with the start sign, and the de-selection sequence must start with the stop sign. Example for Code 3of9:

Selection sequence:                  <27>(10Q><27>(s1p20vsb10000T\*  
De-selection sequence:              \*<27>(0N<28>(sp10hsb4099T

Another example can be found on the utility disk directory SAP.

How to define a Print-Control using the German version of SAP  
R/3: Tools->Administration, Spool->Spool-Administration, Print-Control for device types, Change, HP LaserJet 4, insert Print-Control  
R/4: CCMS, Spool Administration, Output device types, HP Laser, „Hilfsmittel“, Print-Control.

Notes: You may have in the future the need to print some of the others barcodes. That is why we do recommend in stead of the sos8026 module the JetCAPS BarSIMM/DIMM!

Well, for the most used code 3of9 the sos8026 module is quite similar to the BarSIMM/DIMM.

---

## Hex table

	0	1	2	3	4	5	6	7	8	9	10	11	12	13	14	15
0	00	01	02	03	04	05	06	07	08	09	0A	0B	0C	0D	0E	0F
16	10	11	12	13	14	15	16	17	18	19	1A	1B	1C	1D	1E	1F
32	20	21	22	23	24	25	26	27	28	29	2A	2B	2C	2D	2E	2F
48	30	31	32	33	34	35	36	37	38	39	3A	3B	3C	3D	3E	3F
64	40	41	42	43	44	45	46	47	48	49	4A	4B	4C	4D	4E	4F
80	50	51	52	53	54	55	56	57	58	59	5A	5B	5C	5D	5E	5F
96	60	61	62	63	64	65	66	67	68	69	6A	6B	6C	6D	6E	6F
112	70	71	72	73	74	75	76	77	78	79	7A	7B	7C	7D	7E	7F
128	80	81	82	83	84	85	86	87	88	89	8A	8B	8C	8D	8E	8F
144	90	91	92	93	94	95	96	97	98	99	9A	9B	9C	9D	9E	9F
160	A0	A1	A2	A3	A4	A5	A6	A7	A8	A9	AA	AB	AC	AD	AE	AF
176	B0	B1	B2	B3	B4	B5	B6	B7	B8	B9	BA	BB	BC	BD	BE	BF
192	C0	C1	C2	C3	C4	C5	C6	C7	C8	C9	CA	CB	CC	CD	CE	CF
208	D0	D1	D2	D3	D4	D5	D6	D7	D8	D9	DA	DB	DC	DD	DE	DF
224	E0	E1	E2	E3	E4	E5	E6	E7	E8	E9	EA	EB	EC	ED	EE	EF
240	F0	F1	F2	F3	F4	F5	F6	F7	F8	F9	FA	FB	FC	FD	FE	FF

## ASCII table

	0	1	2	3	4	5	6	7	8	9	10	11	12	13	14	15	
32	“	‘	!	“	#	\$	%	&	‘	(	)	*	+	,	-	.	/
48	0	1	2	3	4	5	6	7	8	9	:	;	<	=	>	?	
64	@	A	B	C	D	E	F	G	H	I	J	K	L	M	N	O	
80	P	Q	R	S	T	U	V	W	X	Y	Z	[	\	]	^	_	
96	`	a	b	c	d	e	f	g	h	i	j	k	l	m	n	o	
112	p	q	r	s	t	u	v	w	x	y	z	{		}	~		

---

## Trouble shooting?

### The printer doesn't print barcode:

1. Is the module correct installed? Generate a PCL font list print out and verify if the module is recognized in the slot.
2. Copy one of the demo print out files of the utility disk to the printer. Don't load it into MS Windows applications.

If this all do work, and your application still doesn't print the barcode, verify again the ESC-Sequence. It should start with the <ESC> sign and end with an uppercase 'T'. The barcode data should directly follow after this termination character.

Another good way to start the search is to replace the <ESC> by any printable characters. The printer must print now the sequence as readable text. If not, then the sequence is definitively not received by the printer.

### How to stop barcode printing:

Just send any other font selection sequence after the barcode message. Example: For Courier 12 pt in PC850 symbol set use: <28>(12U<27>(sp10hsb4099T.

### The barcodes of the PCL font list are not readable:

The printer does print only some characters as an example for the font style of the PCL font list. Therefor the barcode format like start/stop signs and check sums are missing! However the correct font esc sequences are printed.

**LJ 4P and Color LaserJet 5:** Please call stethos for further help.

### The space problem:

The alpha numerical barcodes are able to define also a stroke/space set for the space sign. This sign is unfortunately the only unprintable sign for HP laser printers. The sos8026 module does have the space sign codes for those fonts at the character '@'. If you are not able to convert your barcode data, you should use the JetCAPS BarSIMM/DIMM.

### 2of5 interleaved and Code 128 on Color LaserJet 8500 and 8550

Those two types of barcode are not supported on this printers

### LJ 2200 Typeface list

Some Hebrew fonts are listed instead of the names with barcodes. This doesn't effect the printing of those fonts.



---

## Additional Products

Further information to the following products are available via Internet. The URL-Address of stethos is listed on the next page.

### sos8026S compatible products

sos8026K This product is compatible to **sos8026s**. The cartridge is suitable in the following HP laser printer:

Series III, IIID, IIIP, IIISi, 4, 4M, 4 Plus, 4M Plus, 4P, 4Si and 4Si Mx.

Flash-SIMM The HP Flash-SIMM realizes the permanent storage of forms, graphics and fonts in the printer. All in this documentation described barcodes and fonts are available in consumption with a Flash-SIMM as soft fonts.

BarSIMM The JetCAPS<sup>®</sup> BarSIMM is a firmware enhancement for HP laser printers series 4 and newer (not L- and ML-Versions). The Module realizes about 40 in X- and Y-direction free scaleable barcodes. Check digits and the „Interleaving“ is done by the printer. Some software packages like KHK or SAP for realization of barcode printing this product. The ESC-Sequence maybe up to 39 characters.

### Barcodes for Windows

Special MS Windows solution based on TrueType fonts. The attached software do work on all Windows versions and is responsible for all calculations. The result is copied to the clipboard and can be pasted into nearly all applications. The easy to handle DDE interface of the program realizes data communication between your DDE capable application and the software. For example, it will take only view minutes to do mail merging with Word for Windows, including printing data base fields in barcode format.

Barcodes without check digits and „Interleaving“ are suitable in connection with the TrueType fonts without the attached software.

---

## **Barcode Reader**

All listed types of readers are available for keyboard and serial connectivity and portable solutions. The data can be transferred via cable, infrared and bi-directional radio controlled communication. The fully portable systems are also available programmable for your own functionality and with voice control.

Pen readers for easy contact scanning.

CCD Scanner Contact or distance scanner with reading width of 6, 8 and more cm.

Laser scanner Distance scanner beginning of about 15 cm up to several meters with high scanning frequency.

Portable Systems

All above named readers are available for portable systems.

## **Technical support**

For questions, inputs and other reasons, please contact the following addresses:

### **Austria**

Leadtech Marketing Cons. GmbH  
Plunkergasse 3-5  
1150 Wien  
Phone [+43] 1 2 1550-0

### **Czech Republic**

Pro futura consulting s.r.o.  
Freyova 12  
190 00 Praha 9  
Phone: [+420] (0) 2 66316727

### **Denmark:**

EuroForm ApS  
Riskær 15  
DK-2765 Smørum  
Phone: [+45] (0) 4466 8338

### **France:**

DANEL ELECTRONIC SA  
25Bis Avenue Pierre Grenier  
FR-92517 Boulogne Cedex  
Phone: [+33] (0) 1 46104300

---

**Germany**

stethos Systemhaus GmbH®  
Weimarer Str. 48  
D-71065 Sindelfingen  
Phone: [+49] (0) 7031 860910

**Israel**

AutoFont Ltd  
Moshav Olesh #85  
42855 Hashron  
Phone: [+972] (0) 9 8986935/6

**Norway**

Fingerprint  
Gamle Ringeriksvei 6  
NO-1369 STABEKK  
Phone: [+47] (0) 67106660

**Spain**

LISVA  
Ronda de Poniente, 18  
28760 Tres Cantos (Madrid)  
Phone: [+27] (0) 11 7281344

**Sweden**

Swedish Print Solutions AB  
Janne Gustavssons väg 3  
185 34 Vaxholm  
08-544-304-10

**USA**

Capella Technologies, LLC.  
8 Varderbilt, Suite 10  
Irvine, California 92618  
Phone: (949) 597-0402  
WWW: [www.capellatech.com](http://www.capellatech.com) a&l1H

**Hungary**

Controll Training Ltd  
Csalogány u. 23  
Hu-1027 Budapest  
Phone: [+36] (1) 457 69909

**Italy**

Oberon services srl  
Via Bergignone 27  
I-20146 Milan  
Phone: [+39] (0) 2 58104299

**Poland**

Unicorn Sp.z.o.o  
ul. Pasaz Ursynowski 3  
02-784 Warszawa  
Phone: [+48] (0) 22 6488525

**South Africa**

Lindsay Information Syst. LTD  
151 William Rd, Grant Park 2051  
Norwood Johannesburg  
Phone: [+349] (0) 1 8039495

**Turkey**

Sibnet  
Bagdad Cad 204/6 Kadiköy  
81030 Istanbul  
Phone: [+90] (0) 2 164782975

---

HP OCR + Barcode

SIMM sos8026S or  
DIMM sos8026D or  
DIMM sos8026C or  
Cartridge sos8026K

**provides the following functionality:**

- OCR-A1 and OCR-B free scaleable
- All barcodes, OCR and Line Draw fonts of the „Bar Codes & More C2053A#C06” font cartridge
- Scalable Barcodes: Code 39 (Code 3aus9) and 39 extended, 2aus5 interleaved, 2aus5 industrial, 2aus5 matrix, Code 128 A/B/C, UCC-128, EAN 8/13/128, UPC-A, UPC-E 0 und 1, EAN/UPC Addon 2, EAN/UPC Addon 5, EAN Velocity, MSI, Leit- und Identcode der Deutschen Post AG, Code 93 und 93 extended, Codabar
- Printing readable text is optional possible (except Code 128)
- KIX Barcode for the Netherlands Post Office
- For Check-Printing: Micro font, CMC7 and OCR-A1
- Scaleable symbols like broken glass, green point, explosive, recycling, dead head and much more
- VDA 4902 form in 5 different languages
- A test form

Developed and produced by stethos Systemhaus GmbH®.

Distribution Hewlett-Packard GmbH Germany,  
All companies listed in technical support chapter

© stethos Systemhaus GmbH®, Germany