

aurelia
ambera

User Manual



Congratulations on your excellent choice of loudspeaker!

We hope that you will have a great deal of happy audio moments with your Aurelia Ambera loudspeakers for many years to come!

We recommend that you carefully read the user manual through and follow the guidelines which are provided. This will ensure that the installation and first use of the loudspeaker will be both simple and easy.

Thereafter, you will be able to confidently switch your sound reproduction equipment on and enjoy an unprecedented quality of sound.

Installing a stand

The loudspeakers are supplied with stand plates which can be attached to the loudspeakers using the screws which are provided in an equipment bag. The aforementioned equipment bag contains the following:

- Attachment screws 8 pcs
- Platform sleeves 8 pcs
- Pieces of felt 12 pcs

The stand plate is attached to the bottom of the loudspeaker as shown in Figure 2. At the beginning, there is good reason to place the loudspeaker on its side on supports, so that the stand plate can be easily attached to the base of the loudspeaker. The stand plate is attached by the following stages:

1. Remove the pieces of felt from the Velcro band and attach them to the base of the stand plate at the marked locations (see Fig 1). Each base plate should have six pieces of felt.
2. Insert the screws (4 pcs), into the screw holes, located on the bottom of the stand plate.
3. Place the platform sleeves to each screw on the upper side of the plate.
4. Adjust the screws into the holes on the base of the loudspeaker and screw them first, hand tight, to the bottom of the loudspeaker. The holes on the base of the loudspeakers are pre-machined for M5 threaded stand attachment.
5. Finally, the screws are tightened, using a cross-point screwdriver (Phillips). **IMPORTANT!** Avoid excessive tightening of the screws. Excessive tightening may damage the threads on the base of the loudspeakers.
6. Place the loudspeaker in the upright position and move it to the listening location. **IMPORTANT!** Never lift a loudspeaker by its reflex tube.

Fig 1. Attaching the pieces of felt

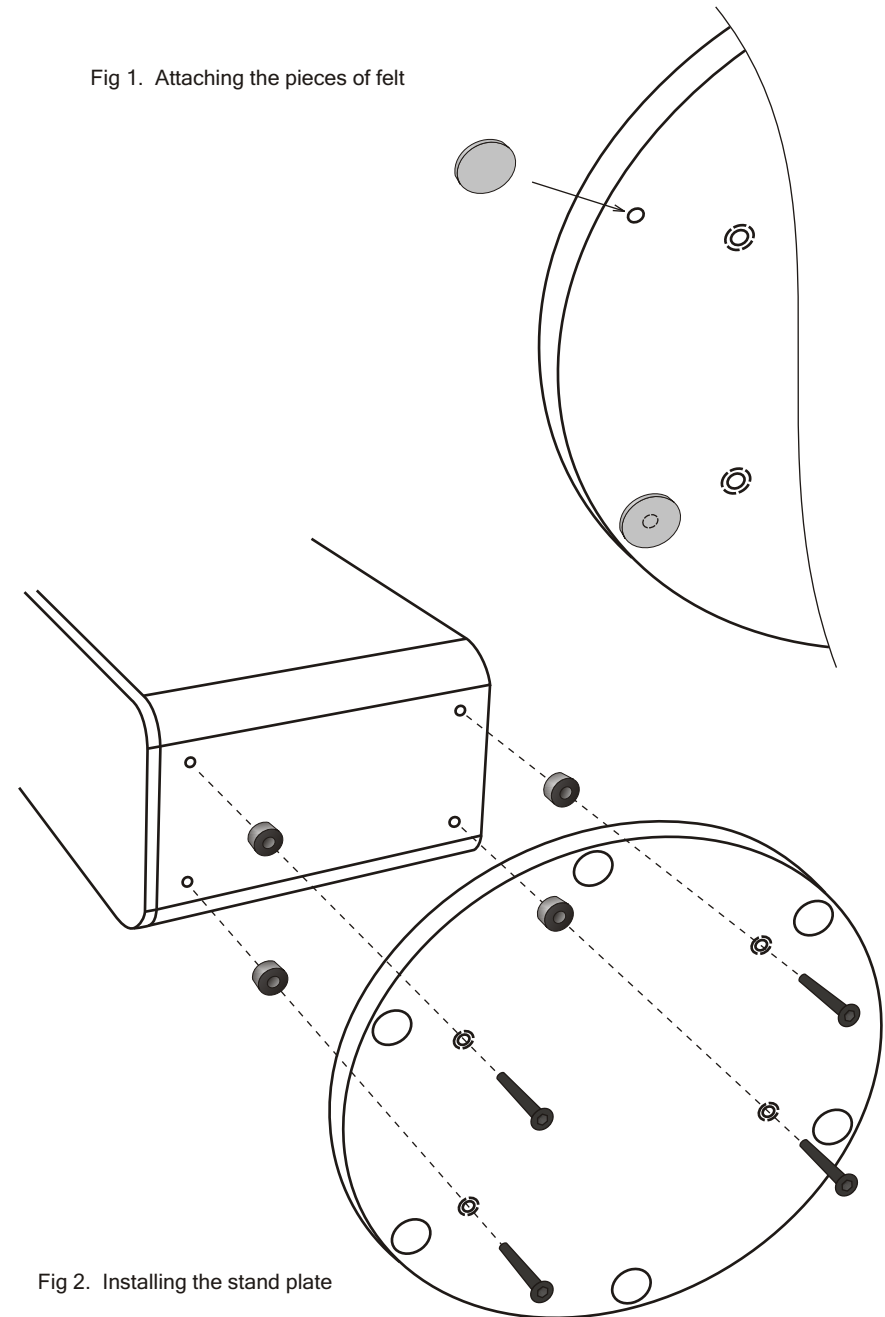

Fig 2. Installing the stand plate

The connection of an amplifier to the loudspeakers

NOTE! Always switch the amplifier off before connecting or disconnecting loudspeaker cables.

The loudspeakers are connected to an amplifier through the connections and speaker cables, located behind the loudspeakers. The right loudspeaker is connected to the amplifier's right channel (R) and the left loudspeaker is connected to the left channel (L). When using a home theatre amplifier, we recommend that compatible Aurelia Magenta loudspeakers are used with Ambera central and rear loud speakers. These are connected to the home theatre amplifiers' central and rear channel outputs. Fork connectors or banana plugs can be used when connecting the loudspeakers. The cables can also be connected to the loudspeakers without connectors, by unpeeling the insulator of the loudspeaker cable for about 10 mm and placing the peeled end in the hole on the side of the connector. The connector screw is rotated open thus that the hole alongside the connector screw becomes visible. The cable is placed in the hole and then the screw is tightened to an appropriate hand tightness. A spanner may also be used for the tightening process. In this case, note should be taken that excessive tightness is not used. The black jack is the (-) pole and the red is the (+) pole. The (+) lead from the loudspeaker is attached to the amplifier's (+) terminal and the (-) lead to the (-) connector.

IMPORTANT! Make sure that the (+) and (-) connectors, leads or their cords do not come into contact with each other, as the amplifier may be damaged. Carefully tighten the connectors so that the cables do not later become loose, possibly resulting in a short circuit. Also, read the user manual for the amplifier to ensure that the connectors to the loudspeakers have been completed correctly.

The positioning of loudspeakers in the listening area

Aurelia Ambera speakers are more directional than ordinary speakers and therefore, their positioning in the listening area is easier than normal. Due to the directionality, sound reflected from walls, the floor and the ceiling is less than normal and as a result of this, high standard sound can also be enjoyed in locations which are acoustically difficult.

The best quality of sound is achieved when the loudspeakers are placed far enough away (min. 50 cm) from the room walls, corners, or other surfaces. The loudspeakers should, if possible, be positioned in such a way that they are equal distance from the listener. The distance between the loudspeakers should be about $2/3$ of their distance from the listening position (Fig 3).

Wider positioning could be tested in softer room acoustics. Generally, it is not recommended to place the speakers farther apart, than their distance from the listening position. It is worthwhile thus, to place the loudspeakers so that the elements are directed towards the listener. In some cases, better results can be achieved by turning the loudspeakers away from the listener, slightly outwards from the shoulder line (Fig 4).

The positioning can affect the clarity of the upper treble. If a darker sound is desired, turn the loudspeakers outwards from the listener, whilst turning the loudspeakers towards the listener will attain a brighter sound. The form, size, building materials and interior decoration of the listening location also have a significant affect on the sound. The most appropriate location for the loudspeakers is found through personal listening and experimenting.

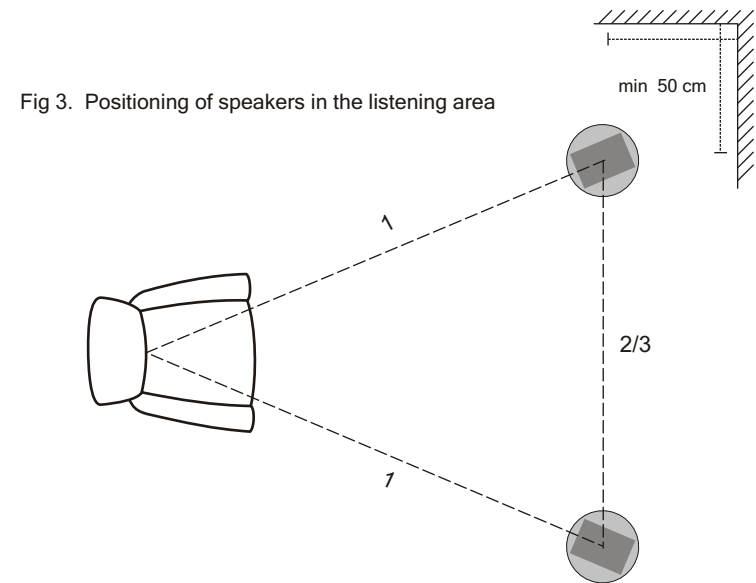
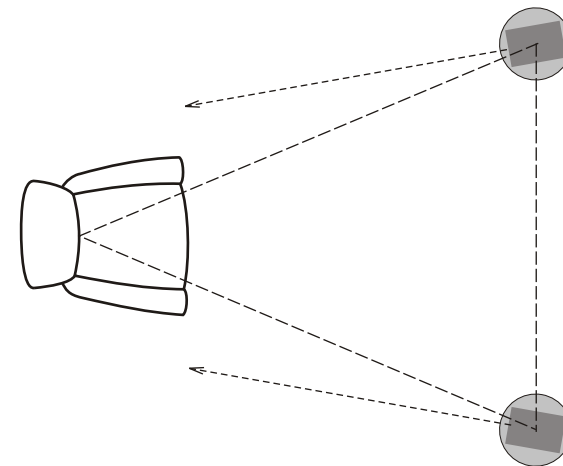

Fig 4. Turning the speakers outwards from the listener



Reflex tube blocking

The blocking of the reflex tubes is recommended in the event that the loudspeakers are placed close to a wall and / or the bass reproduction is accentuated. If a subwoofer is used with the loudspeakers, the best and most uniform sound is often attained when the reflex tubes are blocked.

Cleaning the loudspeakers

When cleaning the surface of the loudspeakers, we recommend using a dry microfiber cloth. To remove difficult stains, the cloth can be moistened with water and when necessary, a mild soapy solution. When using a cleaning fluid to clean a painted or polished surface, there is reason to first try the rear plate of the loudspeaker to ensure that the surface of the loudspeaker is not damaged. For cleaning an aluminium profile, we recommend that the same substances are used as when cleaning painted and varnished surfaces.

Fault situations

All Aurelia loudspeakers are measured, tested and checked at the factory during their manufacture. If an error nonetheless occurs with the loudspeakers, they should be returned to the relevant retailer.

The most common cause of faults are improper cable connections. Ensure that the cabling and connections are made correctly. In the event that no sound can be heard from the loudspeakers, you can check the functionality by switching it to an operating loudspeaker channel. If, in this event, the loudspeaker works, the fault is in another location than the loudspeaker. In so far as the speaker remains silent, it is possible that the speaker has been damaged.

Warranty

The warranty of the loudspeaker is five (5) years, from the date of purchase. The warranty covers faults resulting from the manufacturing process and materials, but not damages as a result of incorrect use of the product. The most common fault caused by incorrect use is related to damage to the tweeter element by an audio level which is too high. Although the Aurelia Ambera tweeter elements have a protection circuit to prevent damage due to wrong use, the tweeter element may however become damaged in extreme cases. The bass units may be damaged when excessive volumes levels are used.

In so far as the sound of the loudspeaker becomes distorted, it may a sign of an excess volume level. In this case, the volume must be lowered immediately. The warranty does compensate for damages caused by audio levels that are too high.

The opening or removal of the loudspeaker's elements, connector panel or any other part will result in the warranty becoming invalid.

Technical specifications

Operational principle	2-way bass reflex
Tweeter element	25 mm titanium, ECW
Bass element	2 x 140 mm DDC
Crossover frequency	1800 Hz
Impedance	8 ohm
Sensitivity	87 dB
Frequency Response	38-20 000 Hz, -6dB
Recommended amplifier power	20-200 W
Dimensions mm (H x W x D)	1020 x 145 x 218
Weight	14.0 kg

aurelia loudspeakers
Tel +358-44-5303935
info@aurelia.fi
www.aurelia.fi

aurelia is a registered trademark, owned by ASL Technosystems OY.