

Compressor Service Manual

for
TM-08
TM-13
TM-15
TM-16
TM-21
TM-31
Compressors



**INTERNATIONAL
COMPONENTS ENGINEERING**

Copyright 2003 • International Components Engineering
Minneapolis, MN, U.S.A. • Printed in U.S.A.
ICE No. 51068 (Rev. 2a, 12/03)



This manual is published for informational purposes only and the information so provided should not be considered as all-inclusive or covering all contingencies. If further information is required, International Components Engineering should be consulted.

Sale of product shown in this manual is subject to International Components Engineering terms and conditions including, but not limited to, the International Components Engineering Limited Express Warranty. Such terms and conditions are available upon request.

International Components Engineering warranty will not apply to any equipment which has been "so repaired or altered outside the manufacturer's plants as, in the manufacturer's judgment, to effect its stability."

No warranties, express or implied, including warranties of fitness for a particular purpose or merchantability, or warranties arising from course of dealing or usage of trade, are made regarding the information, recommendations, and descriptions contained herein. Manufacturer is not responsible and will not be held liable in contract or in tort (including negligence) for any special, indirect or consequential damages, including injury or damage caused to vehicles, contents or persons, by reason of the installation of any product or its mechanical failure.

The compressor is designed for use with R-12 and R-134a for vehicle air conditioning only. Use with other refrigerants will void any warranty.

The ICE compressor is not intended nor designed for use on aircraft.

TM Advantages

Wide Range of Applications

- Single Operator Cabs to Large Trucks, Buses, RVs, and other Specialty Applications.

Smooth Operation

- Balanced Swash Plate design offers low pulsation noise, quiet and smooth operation, less vibration, and lower horsepower requirements.

High Efficiency

- Cooling capacity is stable throughout the entire RPM operating range.

High Durability

- MoS₂ coated steel swash plate provides additional protection during liquid slugging and high load conditions.
- Ball and shoe design promotes lubrication for better compressor durability.
- Needle bearings insure high durability for long life and high speed operation.
- Lip Shaft Seal insures excellent sealing integrity and extends compressor life.

TM-31 ALSO INCLUDES

TM-31 Compressor with Oil Sight Glass

- Ease of maintenance.

Optimized Lubrication System

- Pressure lubrication system provides superior lubrication to cylinder walls, pistons, bearings, and shaft seals.

Recover Refrigerant

At International Components Engineering, we recognize the need to preserve the environment and limit potential harm to the ozone layer that can result from allowing refrigerant to escape into the atmosphere.

We strictly adhere to a policy that promotes the responsible use and handling of CFC/HCFC/HFC refrigerants by using approved recovery and recycling methods and equipment that limits the loss of refrigerant into the atmosphere.

Table of Contents

Safety Precautions	7
Safety Definitions	7
General Safety	7
Refrigerant	8
First Aid	8
Refrigerant Handling	8
Refrigerant Oil	8
First Aid	8
Leak Detection	8
R-134a Applications	9
Polyalkylene Glycol (PAG) Oil Handling Procedures	9
Equipment for R-134a Use Only	9
Compressor Identification Label	10
Introduction	11
Swash Plate System	11
Piston Drive System	11
Compressor System Guidelines	11
Suggested Operating Region	12
Clutch Application Guidelines	13
Compressor Clutch and Fitting Options	15
Dimensions and Specifications	17
TM-08 Ear Mount Dimensions and Specifications	17
TM-08 Alternator Mount Dimensions and Specifications	18
TM-08 Ear Mount Pad-Type Fittings	19
TM-13 Dimensions and Specifications	20
TM-15 Dimensions and Specifications	21
TM-15 Direct Mount Dimensions and Specifications	22
TM-16 Dimensions and Specifications	23
TM-21 Dimensions and Specifications	24
TM-31HD Dimensions and Specifications	25
TM-08 Exploded View	28
TM-13, TM-15, TM-16, TM-21 Exploded View	29
TM-31 Exploded View	30
Tightening Torques	31
Compressor Maintenance: TM-08, TM-13, TM-15, TM-16, TM-21	33
Safety	33
Refrigerant Recovery	33
Compressor Handling	34
Compressor Storage	34
Compressor Removal	34
Operating Compressor	34
Non-Operating Compressor	34
Compressor Installation	34
Installation Precautions	34
Installation Position	35
Mounting Compressors	35
Leak Testing the Compressor	36
Compressor Oil Procedures	36
Compressor Oil Caution Statements	36
Oil Charge Considerations	36
Oil Type Considerations	36
Oil Check Interval	37
Oil Check Procedure	37

Table of Contents

Compressor Maintenance: TM-08, TM-13, TM-15, TM-16, TM-21 (continued)

Clutch Procedures	39
Clutch Run-In	39
Clutch Test	39
Clutch Removal	39
Clutch Inspection	40
Clutch Installation	41
Electrical Connection	42
Shaft Seal Procedures	42
Shaft Seal Removal	42
Shaft Seal Inspection	43
Shaft Seal Installation	43
Shaft Seal Cover Installation (When Equipped)	44
Cylinder Head Procedures	44
Cylinder Head Disassembly—Front and Rear	44
Cylinder Head Inspection	46
Cylinder Head Reassembly	47
Compressor Maintenance: TM-31	51
Safety	51
Refrigerant Recovery	51
Compressor Handling	52
Compressor Storage	52
Compressor Removal	52
Compressor Installation	52
Oil Procedures	53
Clutch Procedures	53
Clutch Run-In	53
Clutch Removal	53
Clutch Inspection	54
Clutch Installation	55
Shaft Seal Procedures	56
Shaft Seal Removal	56
Shaft Seal Installation	56
Appendix – Tools and Kits	59

Safety Precautions

Safety Definitions

Hazard precautions come in the following levels, which you should be familiar with:

 **DANGER:** Denotes the possibility of serious injury or death.

 **WARNING:** Denotes the possibility of serious equipment damage or serious personal injury.

 **CAUTION:** Denotes the possibility of minor to severe equipment damage or personal injury.

 **WARNING:** Make sure all mounting bolts are tight and are the correct length for their particular application. Using an incorrect length bolt may cut a wire and cause an electrical short or penetrate air conditioning components.

 **DANGER:** Use caution with a refrigeration system in a closed or confined area with a limited air supply (for example, a bus or garage). Refrigerant displaces air and can cause oxygen depletion, resulting in suffocation and possible death.

General Safety

 **DANGER:** Refrigerants in the presence of an open flame, spark or electrical short produce toxic gases that are severe respiratory irritants capable of causing death.

 **DANGER: EXPLOSIVE HAZZARD!** Do not close the compressor discharge valve with the unit in operation. Do not start the compressor with the discharge valve closed. This increases internal pressure on the compressor which will cause the compressor to explode.

 **WARNING:** Keep your hands, clothing and tools clear of the fans when the unit is running. This should also be considered when opening and closing the compressor service valves (when equipped).

 **WARNING:** Make sure the gauge manifold hoses are in good condition. Keep them away from belts, fan motors, engine pulleys, and hot surfaces.

 **WARNING:** Do not apply heat to a sealed refrigeration system or container. This increases internal pressure and can cause an explosion.

 **WARNING:** Do not wear jewelry, watches or rings. These items can short out, causing severe burns to the wearer.

 **WARNING:** Wear eye protection when handling compressors. Refrigerant liquid and battery acid can permanently damage the eyes

Refrigerant

 **CAUTION:** When removing refrigerant from a compressor, use a recovery process that minimizes refrigerant loss to the atmosphere. Although fluorocarbon refrigerants are classified as safe, precautions must be observed when handling them.

First Aid

Objectives of first aid for frostbite are to protect the frozen area from further injury, to warm the affected area rapidly, and to maintain respiration.

EYES: For contact with liquid, immediately flush eyes with large amounts of water and get prompt medical attention.

SKIN: Flush area with large amounts of lukewarm water. Do not apply heat. Remove contaminated clothing and shoes. Wrap burns with dry, sterile, bulky dressing to protect from infection/injury. Get medical attention. Wash contaminated clothing before reuse.

INHALATION: Move victim to fresh air and use CPR or mouth-to-mouth ventilation, if necessary. Stay with victim until arrival of emergency medical personnel.

Refrigerant Handling

 **CAUTION:** Never directly heat service cans or put them in hot water heated above 104 F (40 C) since the can may explode and cause personal injury. When it is necessary to heat service cans for charging in cold weather, use warm water at a temperature below 104 F (40 C).

 **CAUTION:** Do not put the charge valve in the warm water.

 **DANGER:** Never put service cans on the engine or the radiator when charging.

 **DANGER:** Never store service cans in direct sunlight, near flame or where the temperature exceeds 104 F (40 C). Always store service cans in a cool dry place.

 **DANGER:** Never throw or strike service cans and never handle the packing carton roughly. Do not use service cans which are damaged or dented. Store service cans out of reach of children.

Refrigerant Oil

 **DANGER:** Avoid refrigeration oil contact with the eyes. Avoid prolonged or repeated contact of refrigeration oil with skin or clothing. Wash thoroughly after handling refrigeration oil to prevent irritation.

First Aid

In case of eye contact, immediately flush with plenty of water for at least 15 minutes. CALL A PHYSICIAN. Wash skin with soap and water.

Leak Detection

 **DANGER:** Do not use a Halide torch for lead detection. When a flame contacts refrigerant, toxic gases are produced which may cause suffocation or even death.

Check manufactures information when using leak detectors. All leak detectors must detect fluorine.

Leaks can be detected by using soap bubbles and with Halogen leak detectors such as G.E. H10G or a portable leak detector. These are commercially available.

R-134a Applications

R-134a is a Hydrofluoro-carbon (HFC) because it contains hydrogen, fluorine, and carbon. It does not contain chlorine.

Always use recommended procedures when servicing equipment:

- Do not vent refrigerant to the atmosphere.
- Recover and reclaim all refrigerants.

 **DANGER:** Store refrigerants in proper containers, out of direct sunlight and away from intense heat.

 **DANGER:** Do not breathe vapors. Use in well-ventilated areas. Refrigerants cause oxygen depletion and death.

 **WARNING:** Wear eye protection and avoid contact with skin. Refrigerant can cause severe frostbite.

 **CAUTION:** Use butyl-lined gloves when handling refrigerants to prevent frostbite.

 **DANGER:** Do not use open flame near refrigerant. Do not burn it as toxic fumes may be released.

 **DANGER:** Do not use Oxygen (O₂) or compressed air for leak testing. An explosion may occur.

Polyalkylene Glycol (PAG) Oil Handling Procedures

 **CAUTION:** Use dedicated equipment for systems containing R-134a to prevent contaminating the system with oil from other systems.

 **CAUTION:** Store oil in sealed containers.

Polyalkylene Glycol (PAG) oil is a hygroscopic oil, which means it absorbs or attracts moisture from the air. Therefore, this oil requires special care and handling procedures. Discard partially used cans of PAG oil.

Equipment for R-134a Use Only

 **CAUTION:** Use dedicated equipment for R-134a to prevent contamination from other refrigerants and compressor oils. If you cannot use dedicated equipment, clean, flush, or purge equipment before using to avoid contamination.

 **CAUTION:** Mixing of refrigerants or oils in the compressor may damage your pump.

- Gauge Manifold.
- All service hoses.
- All adaptors and fittings.
- Micron Gauge optional, but must be used with refrigerant dedicated hoses.
- Vacuum pump. (5 cfm size [0.14 meter³/min.] or larger recommended).
- Recovery and recycling equipment.
- Proper storage equipment for refrigerants and oils.
- Suction service filter(s) for system clean-up (if needed).

NOTE: The larger the size of the vacuum pump, the faster the evacuation process.

Compressor Identification Label

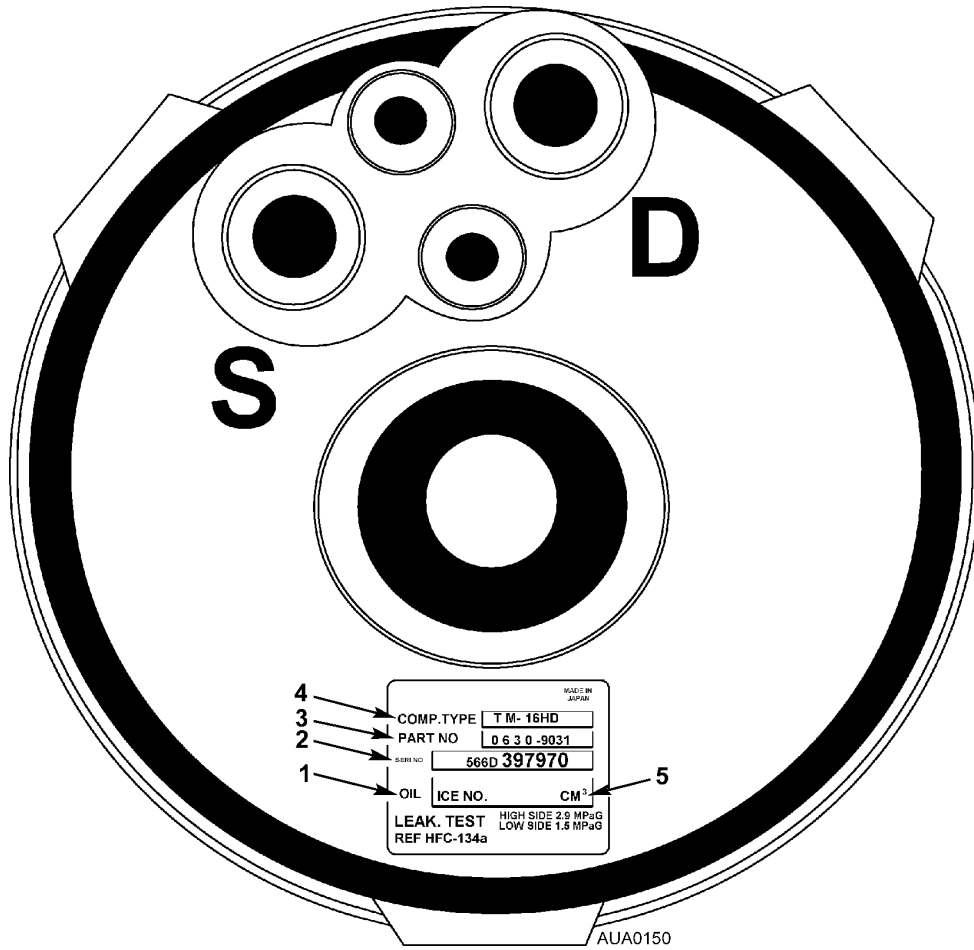

1.	ICE Oil Number	4.	Compressor Type (Model)
2.	Manufactures Serial Number	5.	Compressor Oil Charge
3.	ICE Part Number 4		

Compressor Identification Label

Introduction

Swash Plate System

The driveshaft is supported by two radial bearings and two thrust bearings. As the swash plate reciprocates through the rotation of the drive shaft, the pistons are driven back and forth.

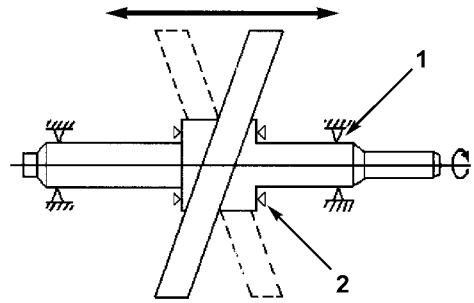

1.	Radial Bearing
2.	Thrust Bearing

Piston Drive System

The pistons in the cylinders are mounted on the swash plate through a ball and shoe disk. Each piston has a compression head at each end. Swash plate rotation results in reciprocating piston movement parallel to the driveshaft. The cylinders are arranged at intervals around the driveshaft, providing 5 front and 5 rear bores.

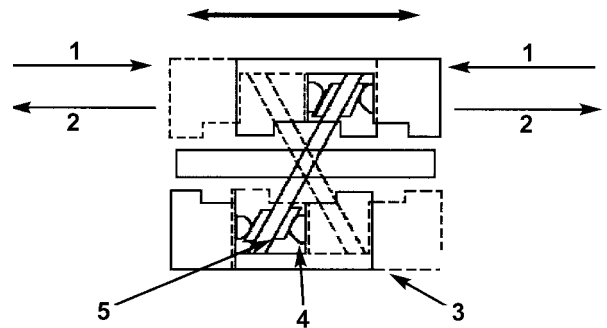

1.	Suction
2.	Compression
3.	Pistons
4.	Ball
5.	Shoe Disk

Compressor System Guidelines

- The specified rotation of the TM-08, TM-13, TM-15, TM-16, and TM-21 is clockwise or counterclockwise.
- The specified rotation of the TM-31 is clockwise as viewed from the clutch side.
- The compressor must be operated within the conditions shown below.

Item	Condition
Ambient Temperature	Under 212 F (100 C)
Speed	6000 rpm maximum
Pressure	Max: 284 psig (1960 KPa)



CAUTION: The A/C system pressure must not exceed 284 psig (1960 KPa).

Suggested Operating Region

The figure below shows the suggested operating region for compressors using R-134a refrigerant:

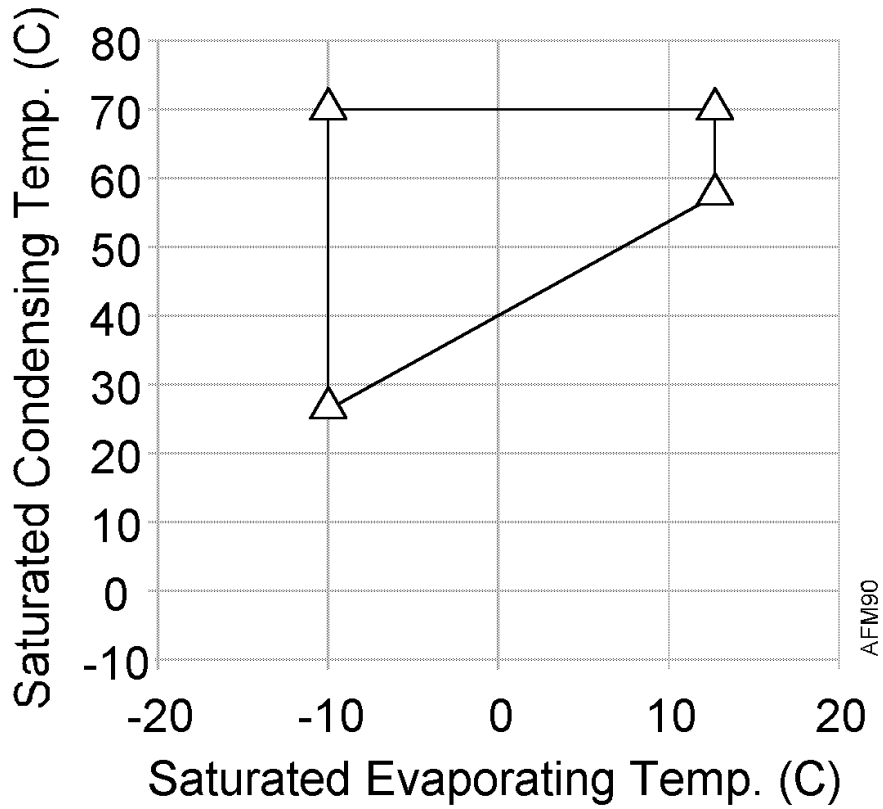
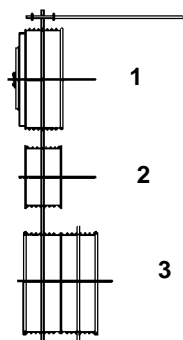

Figure 1: R-134a Compressor Operation Map

Clutch Application Guidelines



1.	Magnetic Clutch
2.	Idle Pulley
3.	Drive Pulley

- Ratio of magnetic clutch to drive pulley:

NOTE: *Pulley ratio is defined as the ratio of the magnetic clutch diameter to the drive pulley diameter.*

- To avoid vibration and resonance, avoid pulley ratio ranges between 1:0.92 and 1:1.08.
- Compressor speed must not exceed the specified speed.
- Pulley alignment tolerance is less than 0.049 in. (1 mm).
- Belt tension must be adjusted to the specified tension. See belt manufacturer or system specifications for tension guidelines.

Compressor Clutch and Fitting Options

Compatible
with
R-134a & R-12

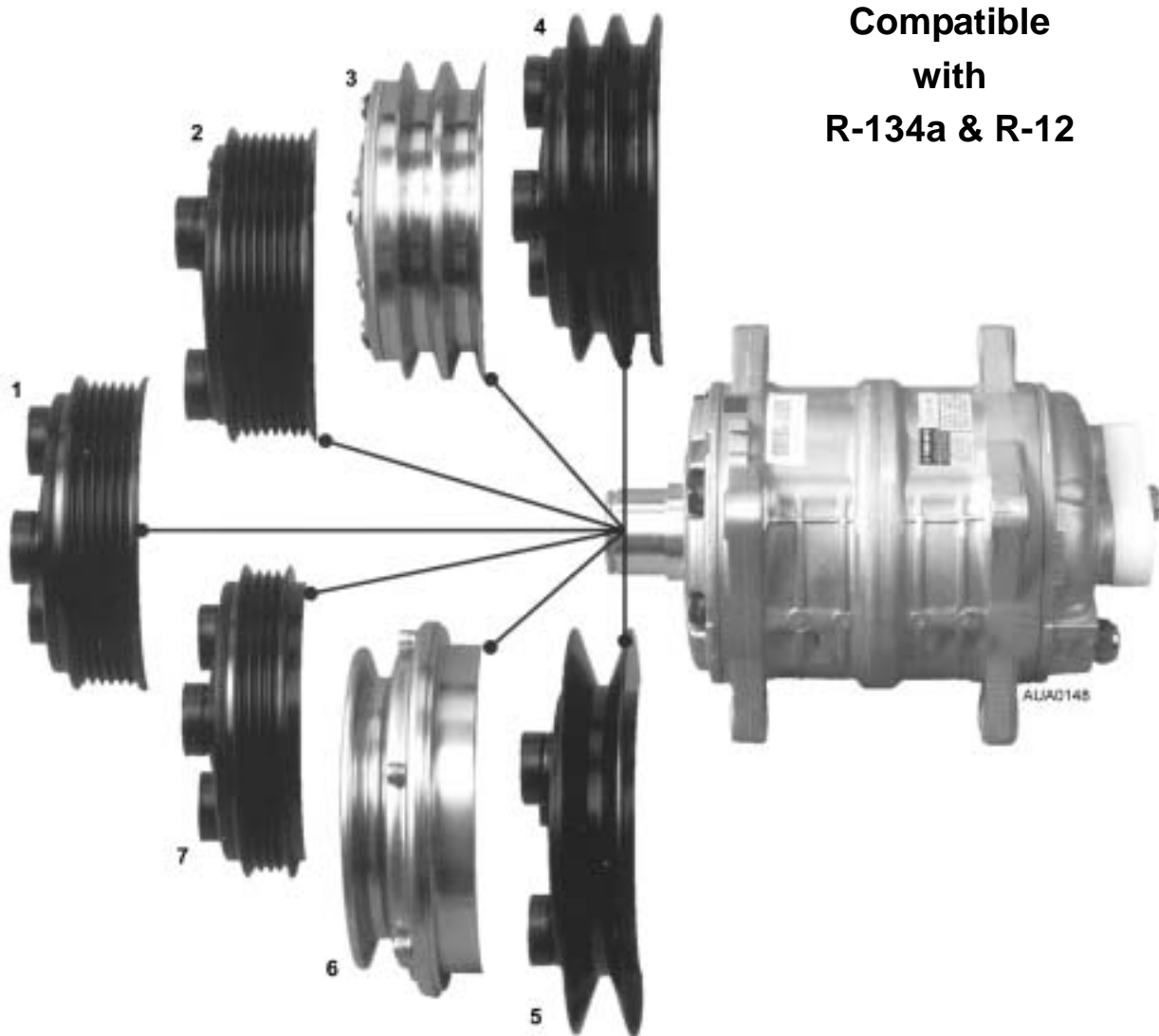

Clutch Options

1.	6 Groove
2.	8 Groove
3.	125 mm Double A Groove
4.	135 mm Double A Groove
5.	Variable Groove
6.	Overhang
7.	4 Groove

Capacities Available

TM-08 (82 cc)
TM-13 (131 cc)
TM-15 (147 cc)
TM-16 (163 cc)
TM-21 (215 cc)

**Compatible
with
R-134a & R-12**

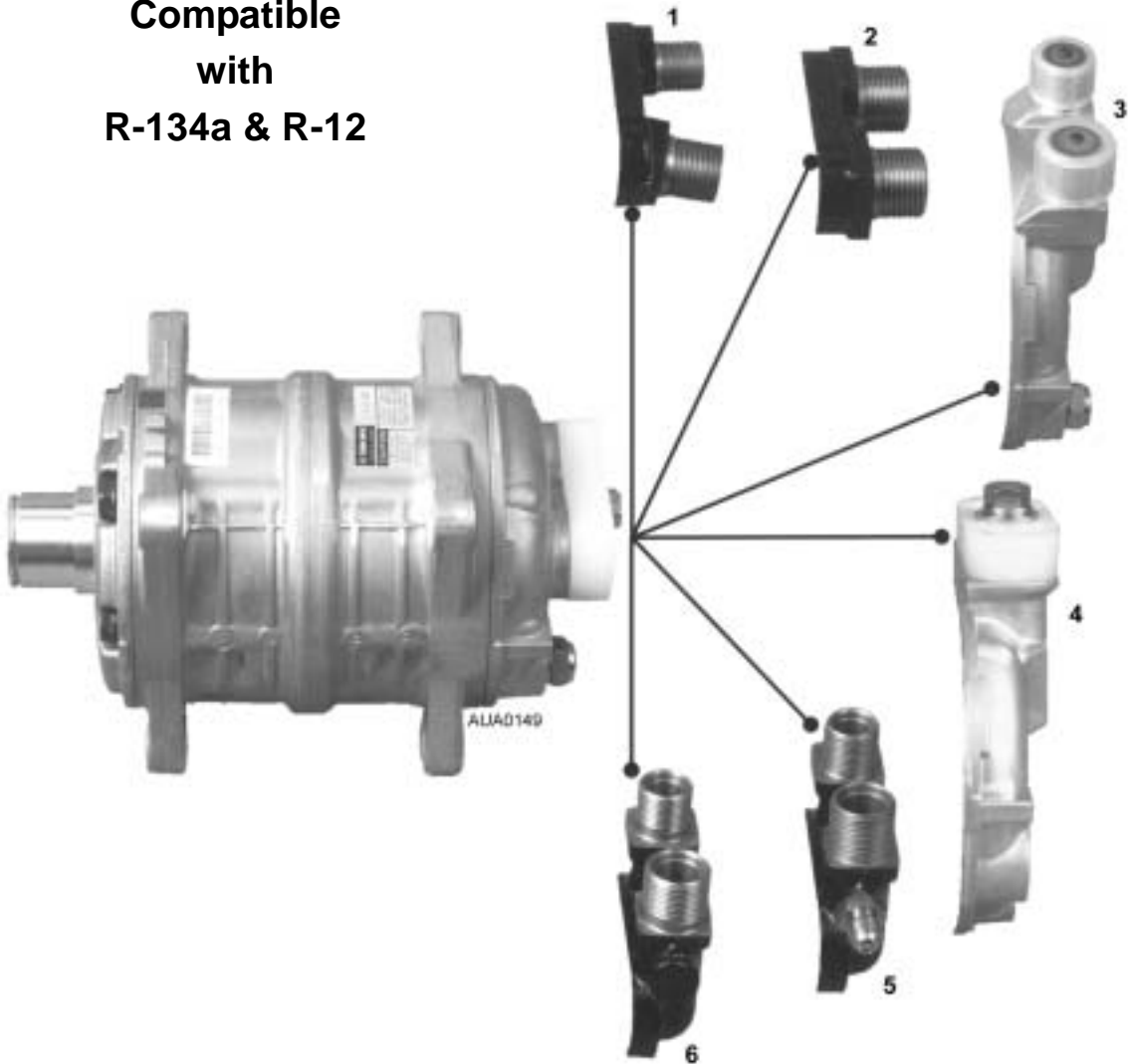

Fitting Options

1.	3/4 X 7/8 Horizontal O-ring
2.	1 X 14 Horizontal O-ring
3.	Most ICE Compressors are available with 3/4 X 7/8 Monolithic O-ring Configuration
4.	Vertical Pad
5.	3/4 X 7/8 Vertical O-ring (R-12)
6.	3/4 X 7/8 or 1X14 Vertical O-ring

Capacities Available

TM-08 (82 cc)
TM-13 (131 cc)
TM-15 (147 cc)
TM-16 (163 cc)
TM-21 (215 cc)

Dimensions and Specifications

TM-08 Ear Mount Dimensions and Specifications

NOTE: Sample configuration shown. Some specifications may vary.

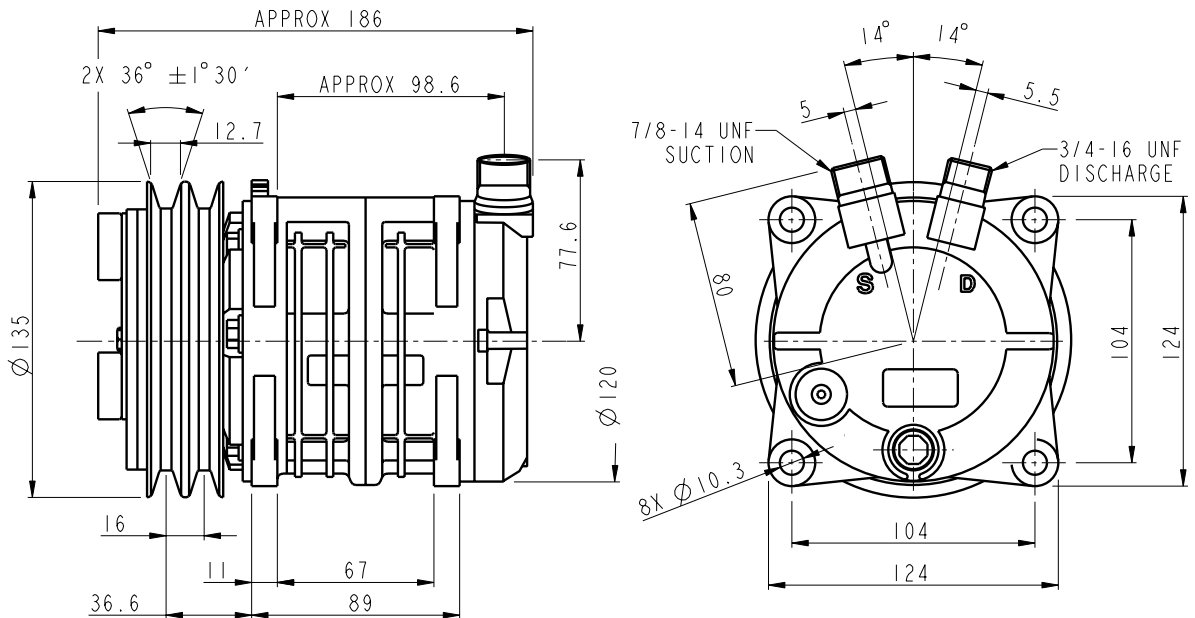

Compressor Specifications

Model	TM-08HD
Type	Swash Plate type
Number of Cylinders	6
Bore	36 mm (1.42 in)
Stroke	13.4 mm (0.53 in.)
Displacement	82 cm ³ (5 cu. in)
Permissible Speed	700-6000 rpm
Refrigerant	R-134a
Lubricant	Oil - ICE No. 2560101 (1 L PAG)
Oil Charge	150 ⁺²⁰ cm ³
Mass	4.1kg (9.1 lbs)

Magnetic Clutch Specifications

Type	Electromagnetic Single-Plate Dry Clutch
Rated Voltage	12/24 volts DC
Belt	2A Type
Current Consumption	3.75 amperes (max)
Static Torque	Initial: 35 N•m (3.5 kgfm) After burnishing: 49 N•m (5 kgfm)
Rotation	CW/CCW
Weight	2.2 kg (4.9 lbs)



CAUTION: Check system decals and operation manual for oil type. Mixing incompatible oils causes system damage. Compressor Oil ICE No. 2560101 (1L PAG) recommended for R-134a Systems.

TM-08 Alternator Mount Dimensions and Specifications

NOTE: Sample configuration shown. Some specifications may vary.

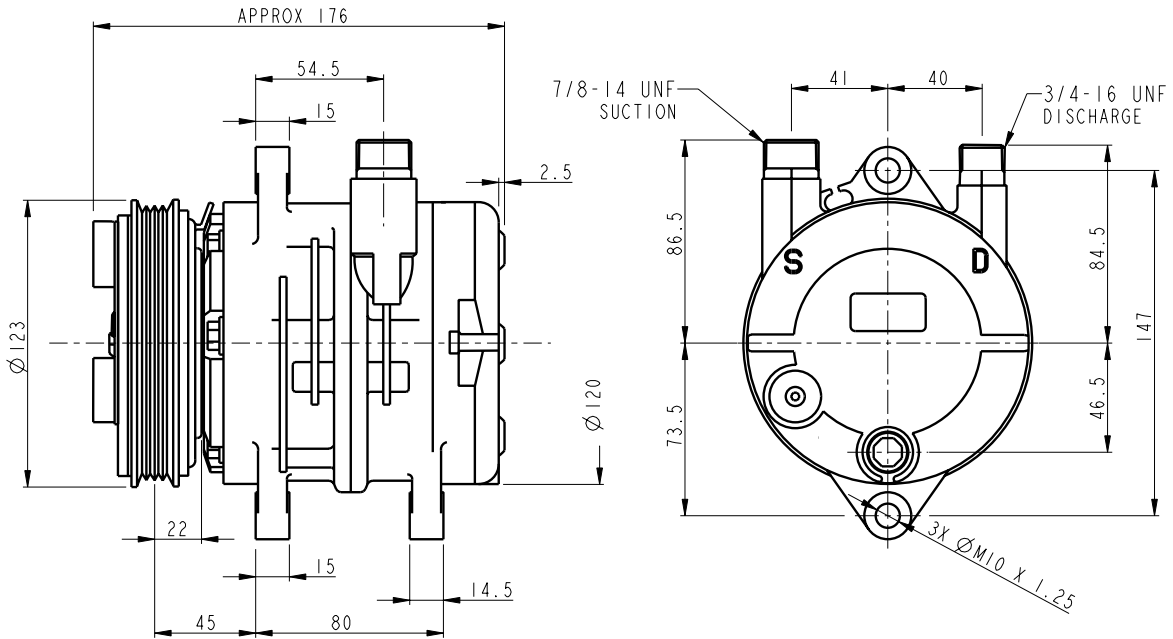

Compressor Specifications

Model	TM-08HD
Type	Swash Plate type
Number of Cylinders	6
Bore	36 mm (1.42 in)
Stroke	13.4 mm (0.53 in)
Displacement	82 cm ³ (5 cu. in)
Permissible Speed	700-6000 rpm
Refrigerant	R-134a
Lubricant	Oil-ICE No. 2560101 (1 L PAG)
Oil Charge	150 ⁺²⁰ cm ³
Mass	4.1kg (9.1 lbs)

Magnetic Clutch Specifications

Type	Electromagnetic Single Plate Dry Clutch
Rated Voltage	12/24 volts DC
Belt	Ply "V" 4K type
Current Consumption	3.75 amperes (max)
Static Torque	Initial: 35 N•m (3.5 kgfm) After burnishing: 49 N•m (5 kgfm)
Rotation	CW/CCW
Weight	2.2 kg (4.9 lbs)



CAUTION: Check system decals and operation manual for oil type. Mixing incompatible oils causes system damage. Compressor Oil ICE No. 2560101 (1L PAG) recommended for R-134a Systems.

TM-08 Ear Mount Pad-Type Fittings

NOTE: Sample configuration shown. Some specifications may vary.

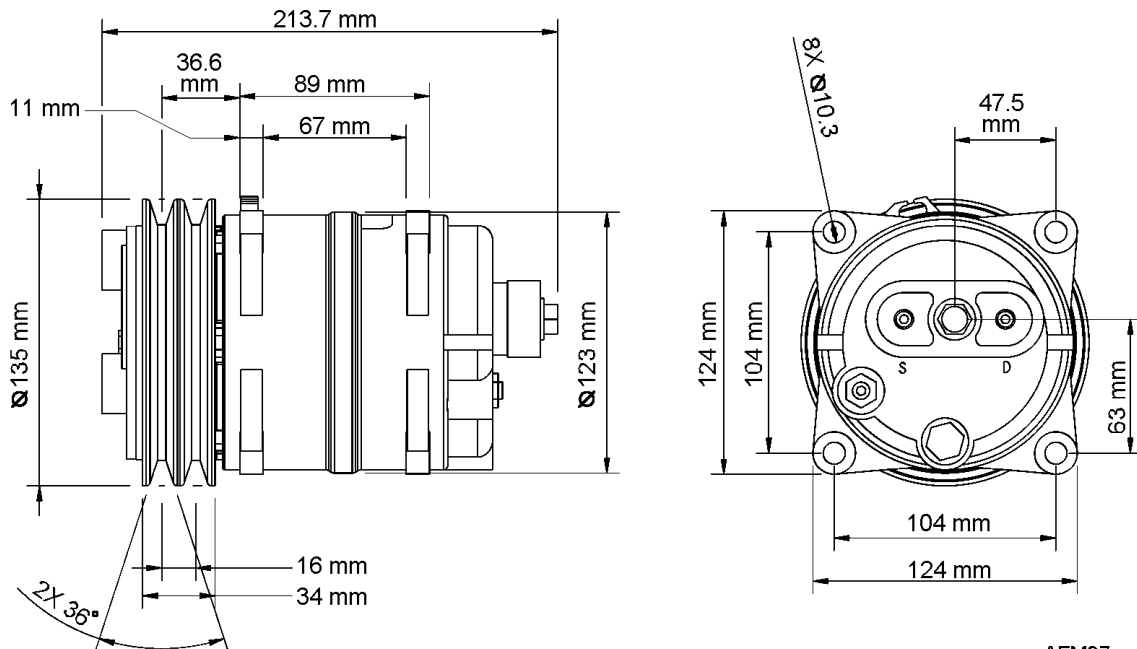

AFM97

Compressor Specifications

Model	TM-08HD
Type	Swash Plate type
Number of Cylinders	6
Bore	36 mm (1.42 in)
Stroke	13.4 mm (0.53 in)
Displacement	82 cm ³ (5 cu. in)
Permissible Speed	700-6000 rpm
Refrigerant	R-134a
Lubricant	Oil-ICE No. 2560101 (1 L PAG)
Oil Charge	150 ⁺²⁰ cm ³
Mass	4.1kg (9.1 lbs)

Magnetic Clutch Specifications

Type	Electromagnetic Single Plate Dry Clutch
Rated Voltage	12/24 volts DC
Belt	Ply "V" 8K type
Current Consumption	3.75 amperes (max)
Static Torque	Initial: 35 N•m (3.5 kgfm) After burnishing: 49 N•m (5 kgfm)
Rotation	CW/CCW
Weight	2.2 kg (4.9 lbs)



CAUTION: Check system decals and operation manual for oil type. Mixing incompatible oils causes system damage. Compressor Oil ICE No. 2560101 (1L PAG) recommended for R-134a Systems.

TM-13 Dimensions and Specifications

NOTE: Sample configuration shown. Some specifications may vary.

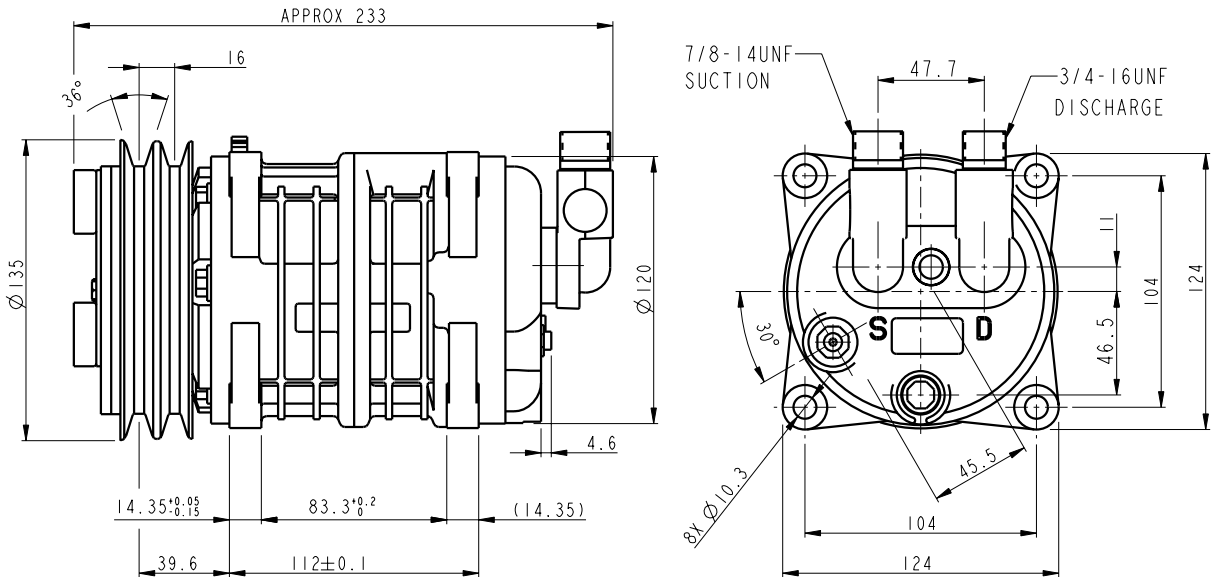

Compressor Specifications

Model	TM-13HD
Type	Swash Plate type
Number of Cylinders	6
Bore	36 mm (1.42 in)
Stroke	21.4 mm (0.84 in)
Displacement	131 cm ³ (8 cu. in)
Permissible Speed	700-6000 rpm
Refrigerant	R-134a
Lubricant	Oil -ICE No. 2560101 (1 L PAG)
Oil Charge	150 ⁺²⁰ cm ³
Mass	4.4 kg (9.7 lbs)

Magnetic Clutch Specifications

Type	Electromagnetic Single Plate Dry Clutch
Rated Voltage	12/24 volts DC
Belt	2A type
Current Consumption	3.75 amperes (max)
Static Torque	Initial: 35 N•m (3.5 kgfm) After burnishing: 49 N•m (5 kgfm)
Rotation	CW/CCW
Weight	2.25 kg (5.0 lbs)



CAUTION: Check system decals and operation manual for oil type. Mixing incompatible oils causes system damage. Compressor Oil ICE No. 2560101 (1L PAG) recommended for R-134a Systems.

TM-15 Dimensions and Specifications

NOTE: Sample configuration shown. Some specifications may vary.

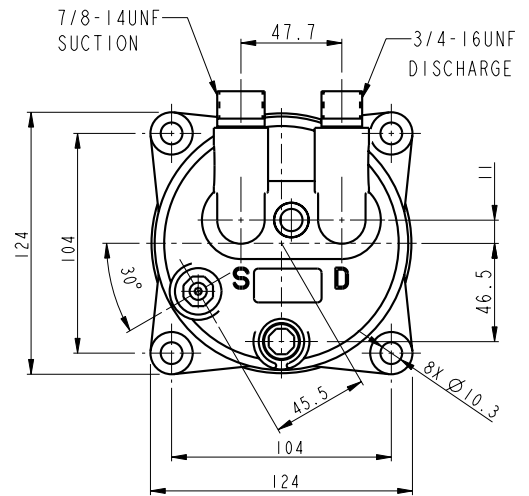
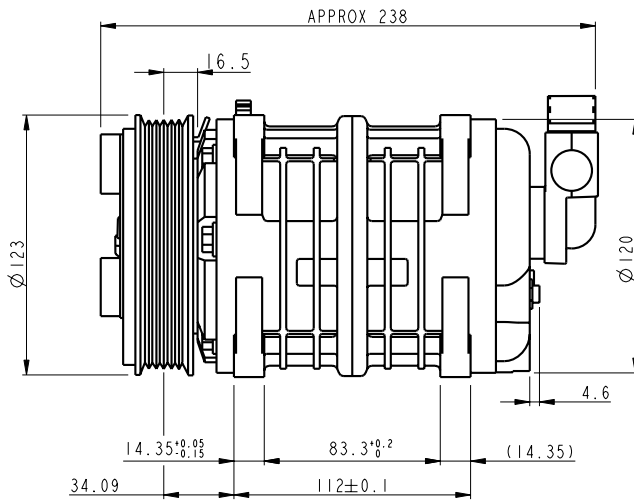

Compressor Specifications

Model	TM-15HD
Type	Swash-Plate type
Number of Cylinders	6
Bore	36 mm (1.42 in)
Stroke	24 mm (0.94 in)
Displacement	146 cm ³ (8.9 cu. in)
Permissible Speed	700-6000 rpm
Refrigerant	R-134a
Lubricant	Oil - ICE No. 2560101 (1 L PAG) 150 ⁺²⁰ cm ³
Mass	4.4 kg (9.7 lbs)

Magnetic Clutch Specifications

Type	Electromagnetic Single-Plate Dry Clutch
Rated Voltage	12/24 volts DC
Belt	Ply "V" 6K type
Current Consumption	3.75 amperes (max)
Static Torque	Initial: 35 N•m (3.5 kgfm) After burnishing: 49 N•m (5 kgfm)
Rotation	CW/CCW
Weight	2.28 kg (5 lbs)



CAUTION: Check system decals and operation manual for oil type. Mixing incompatible oils causes system damage. Compressor Oil ICE No. 2560101 (1L PAG) recommended for R-134a Systems.

TM-15 Direct Mount Dimensions and Specifications

NOTE: Sample configuration shown. Some specifications may vary.

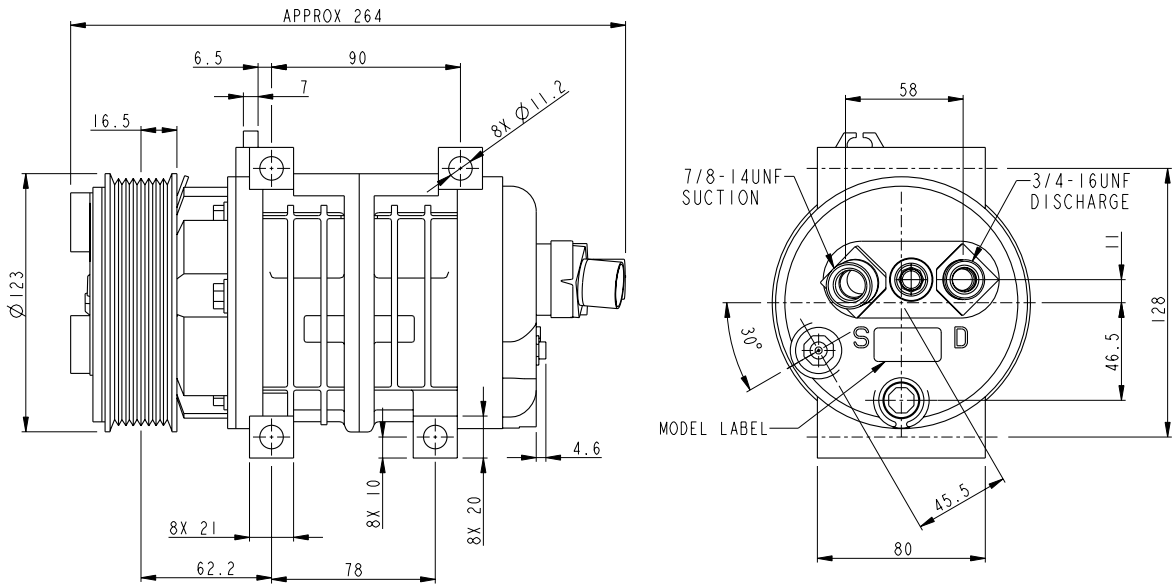

Compressor Specifications

Model	TM-15HD-Direct Mount
Type	Swash Plate type
Number of Cylinders	6
Bore	36 mm (1.42 in)
Stroke	24.0 mm (0.94 in)
Displacement	147cm ³ (8.97 cu. in)
Permissible Speed	700-6000 rpm
Refrigerant	R-134a
Lubricant	Oil-ICE No. 2560101 (1 L PAG)
Oil Charge	180 ⁺²⁰ cm ³
Mass	4.5 kg (9.9 lbs)

Magnetic Clutch Specifications

Type	Electromagnetic Single Plate Dry Clutch
Rated Voltage	12/24 volts DC
Belt	Ply "V" 8K type
Power Consumption	45 max 45 W @ 25 C (77 F)
Static Torque	Initial: 35 N•m (3.5 kgfm) After Burnishing: 49 N•m (5 kgfm)
Rotation	CW/CCW
Weight	2.3 kg (5.07 lbs)



CAUTION: Check system decals and operation manual for oil type. Mixing incompatible oils causes system damage. Compressor Oil ICE No. 2560101 (1L PAG) recommended for R-134a Systems.

TM-16 Dimensions and Specifications

NOTE: Sample configuration shown. Some specifications may vary.

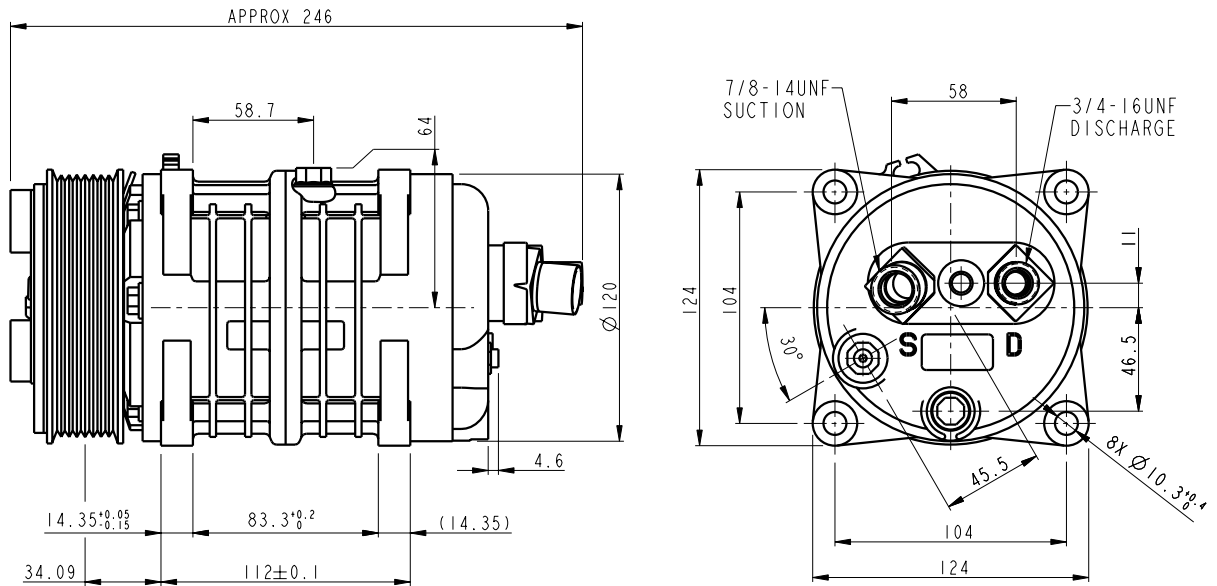

Compressor Specifications

Model	TM-16HD
Type	Swash Plate type
Number of Cylinders	6
Bore	36 mm (1.42 in)
Stroke	26.7 mm (1.05 in)
Displacement	163 cm ³ (9.95 cu. in)
Permissible Speed	700-6000 rpm
Refrigerant	R-134a
Lubricant	Oil-ICE No. 2560101 (1 L PAG)
Oil Charge	150 cm ³
Mass	4.9 kg (10.8 lbs)

Magnetic Clutch Specification

Type	Electromagnetic Single Plate Dry Clutch
Rated Voltage	12/24 volts DC
Belt	Ply "V" 8K
Current Consumption	3.75 amperes (max)
Static Torque	Initial: 35 N•m (3.5 kgfm) After burnishing: 49 N•m (5 kgfm)
Rotation	CW/CCW
Weight	2.3 kg (5.1 lbs)



CAUTION: Check system decals and operation manual for oil type. Mixing incompatible oils causes system damage. Compressor Oil ICE No. 2560101 (1L PAG) recommended for R-134a Systems.

TM-21 Dimensions and Specifications

NOTE: Sample configuration shown. Some specifications may vary.

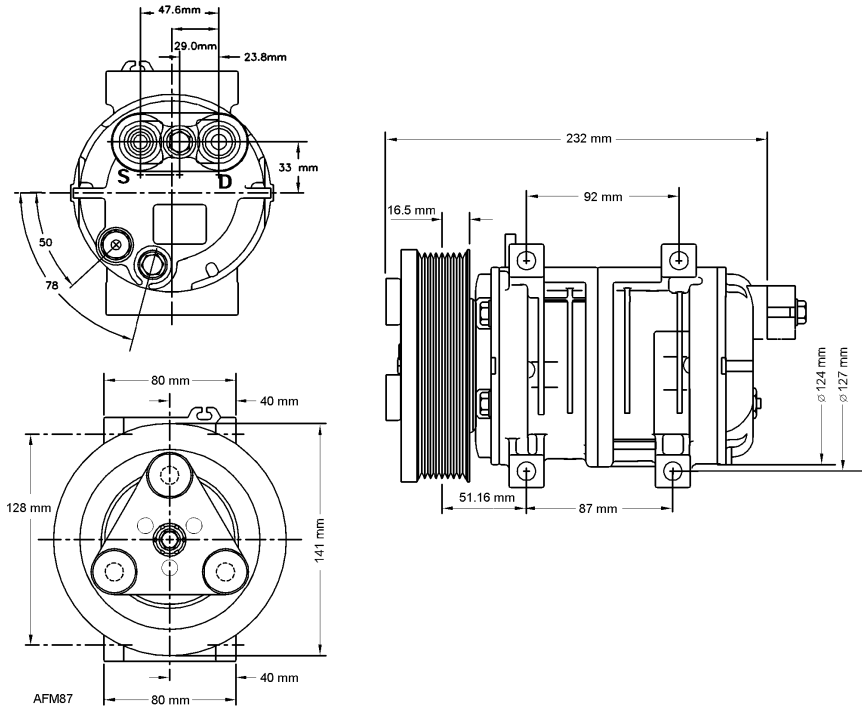

TM-21 Compressor Dimensions

Model	TM 21HD
Type	Swash-plate type
Number of Cylinders	10
Bore	1.26 in. (32 mm)
Stroke	1.05 in. (26.7 mm)
Displacement	13 cu. in. (215 cm ³)
Permissible Speed	700 to 6000 rpm
Refrigerant	R-134a
Compressor Oil ¹	See note below
Mass	11.3 lbs (3.1 kg)

¹ Depending on application, this compressor can be used with different and non-compatible compressor oils. See unit labels for proper oil. The initial installer is responsible for proper labeling.

Magnetic Clutch

Type	Electromagnetic, single-plate dry clutch
Rated Voltage	12 or 24 Volts dc
Current Consumption	3.75 amperes (MAX)
Stalling Torque	59 N•m (43.5 ft. lb)
Rotation	CW/CCW
Mass	6.8 lbs (3.1 kg)



CAUTION: Check system decals and operation manual for oil type. Mixing incompatible oils causes system damage. Compressor Oil ICE No. 2560101 (1L PAG) recommended for R-134a Systems.

TM-31HD Dimensions and Specifications

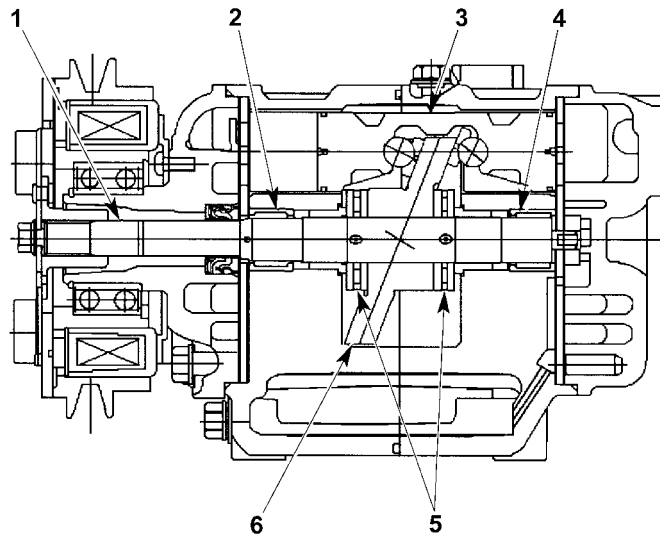

1.	Drive Shaft
2.	Radial Bearing
3.	Piston
4.	Radial Bearing
5.	Thrust Bearing
6.	Swash Plate

TM-31 Internal Components

Dimensions and Specifications

NOTE: Sample configuration shown. Some specifications may vary.

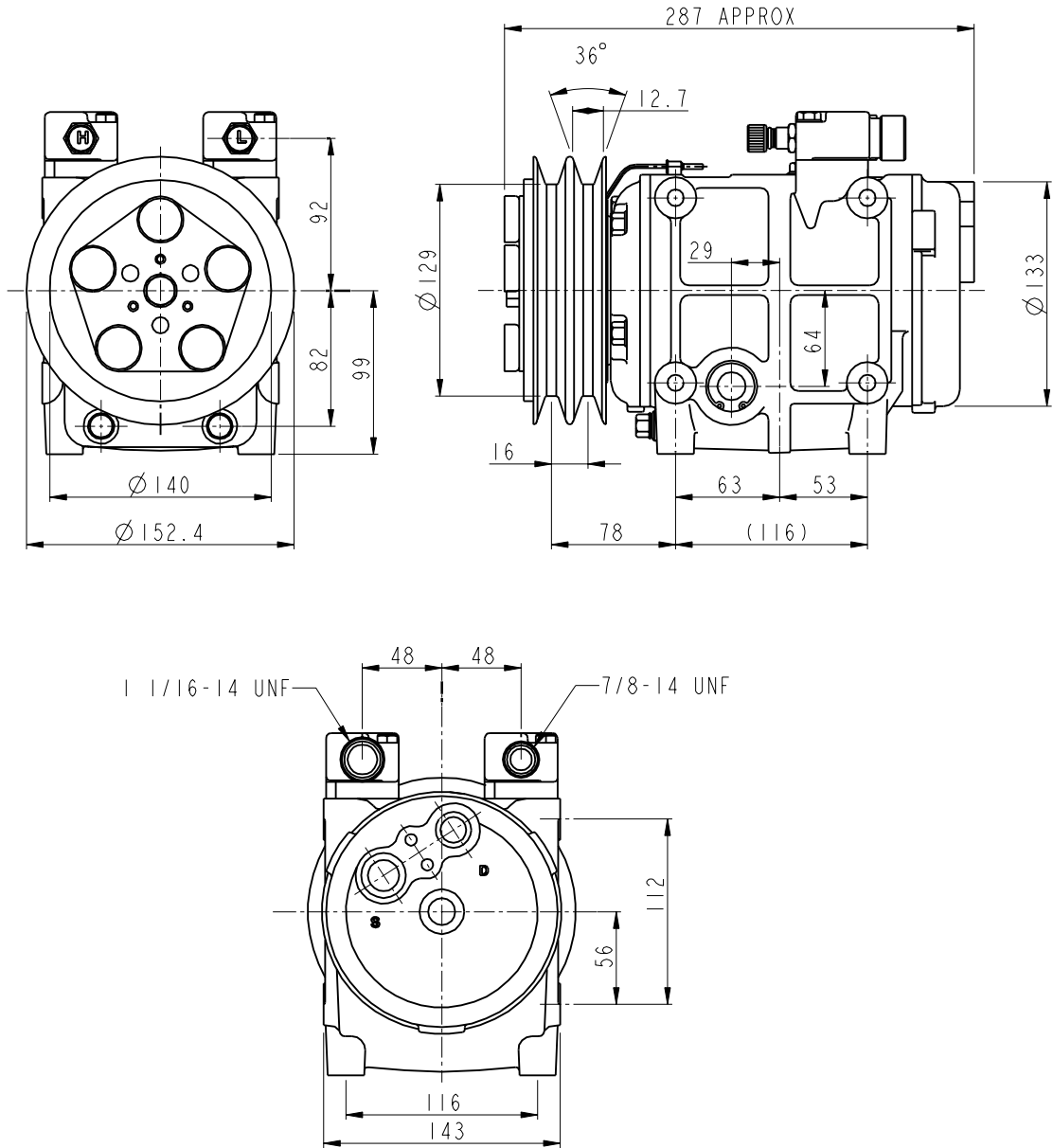

Figure 2: TM-31

Model	TM-31
Type	Swash Plate
Number of Cylinders	10
Bore	36 mm (1.42 in.)
Stroke	30.7 mm (1.21 in.)
Displacement	313 cm ³ (19.1 cu. in.)
Maximum Speed	6000 rpm
Direction of Rotation	Clockwise, viewed from clutch
Lubrication System	Gear Driven Positive Pressure
Lubricant	Oil - ICE No. 2560101 (1 L PAG)
Oil Charge	500 cc (16.9 fl. oz.)
Refrigerant	R-134a
Shaft Seal	Shaft Seal Lip Seal Type
Weight	9.5 kg (21 lbs)

TM-31 Compressor Specifications

Type	Electro Magnetic Single Plate Dry Clutch
Rated Voltage	12 V DC/ 24 V DC
Current Consumption	46 Watts @ 25 C
Static Torque	78.1 N•m (8.0 kgf-m, 58 ft-lb)
Direction of Rotation	Clockwise, viewed from clutch
Weight	Approximate 4.7 kg (10 lbs)

TM-31 Magnetic Clutch Specifications



CAUTION: Check system decals and operation manual for oil type. Mixing incompatible oils causes system damage. Compressor Oil ICE No. 2560101 (1L PAG) recommended for R-134a Systems.

TM-08 Exploded View

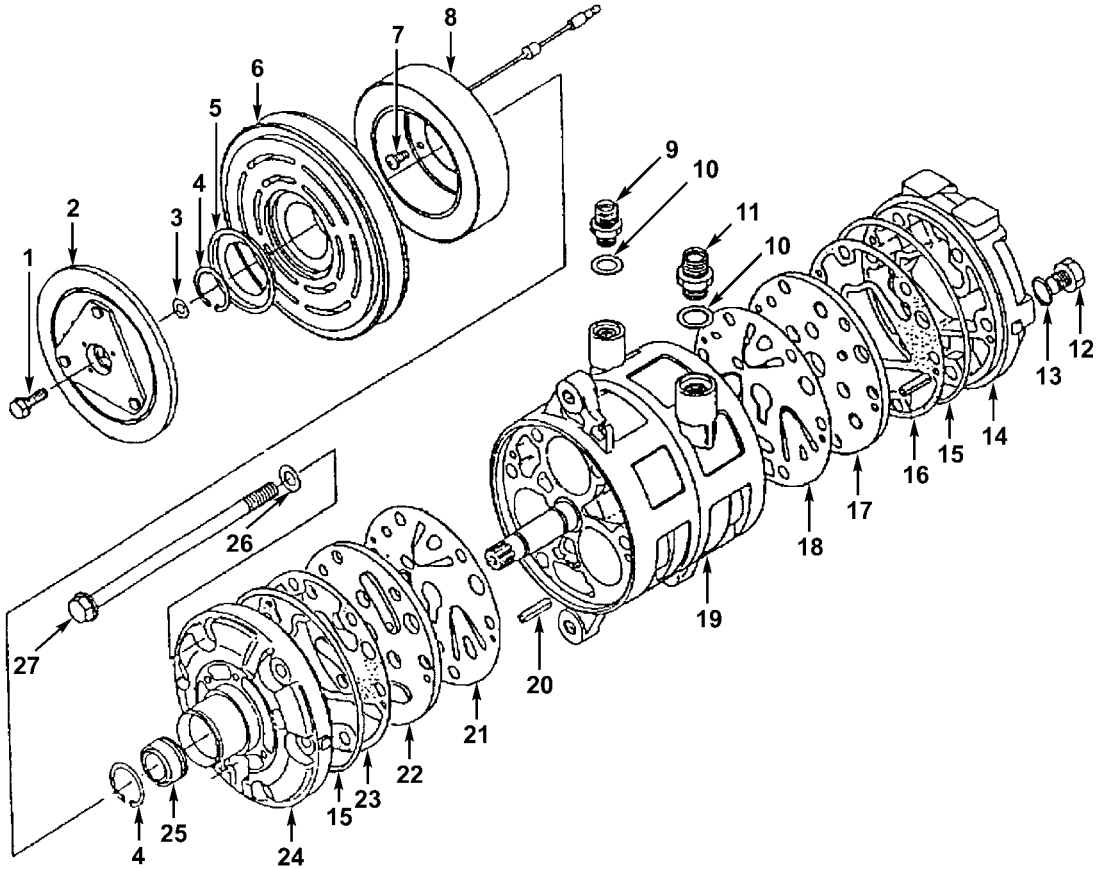

1.	Armature Bolt	15.	O-ring Body
2.	Armature Plate	16.	Rear Gasket
3.	Shim	17.	Rear Valve Plate
4.	Snap Ring	18.	Rear Suction Valve
5.	Cover	19.	Cylinder Shaft Assembly
6.	Pulley Assembly	20.	Pressure Relief Valve
7.	Coil Screw	21.	Front Suction Valve
8.	Coil	22.	Front Valve Plate
9.	Discharge Fitting	23.	Front Gasket
10.	Gasket Fitting	24.	Front Cylinder Head
11.	Suction Fitting	25.	Shaft Seal
12.	Oil Fill Plug	26.	Washer
13.	O-ring	27.	Body Bolt
14.	Rear Cylinder Head		

TM-13, TM-15, TM-16, TM-21 Exploded View

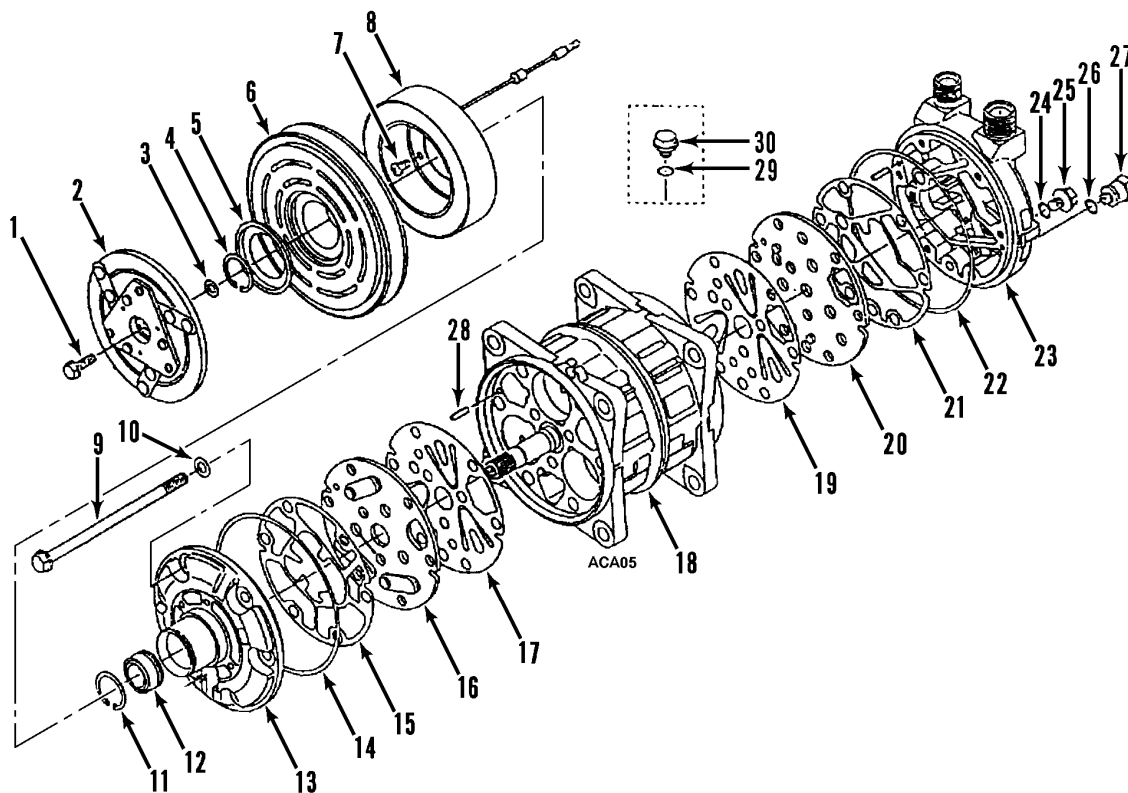

1.	Bolt, Armature	16.	Front Valve Plates
2.	Armature Plate	17.	Front Suction Valve
3.	Shim	18.	Cylinder Shaft Assembly
4.	Snap Ring	19.	Rear Suction Valve
5.	Cover	20.	Rear Valve Plate
6.	Pulley Assembly	21.	Rear Gasket
7.	Screw, Coil	22.	O-ring, Body
8.	Coil	23.	Rear Cylinder Head
9.	Body Bolt	24.	O-ring, Drain Plug
10.	Washer	25.	Drain Plug
11.	Snap Ring	26.	Pressure Relief Valve
12.	Shaft Seal	27.	Pressure Relief Valve
13.	Front Cylinder Head	28.	Pin, Alignment
14.	O-ring, Body	29.	O-ring, Oil Fill Plug (TM16)
15.	Front Gasket	30.	Oil Fill Plug (TM16)

TM-31 Exploded View

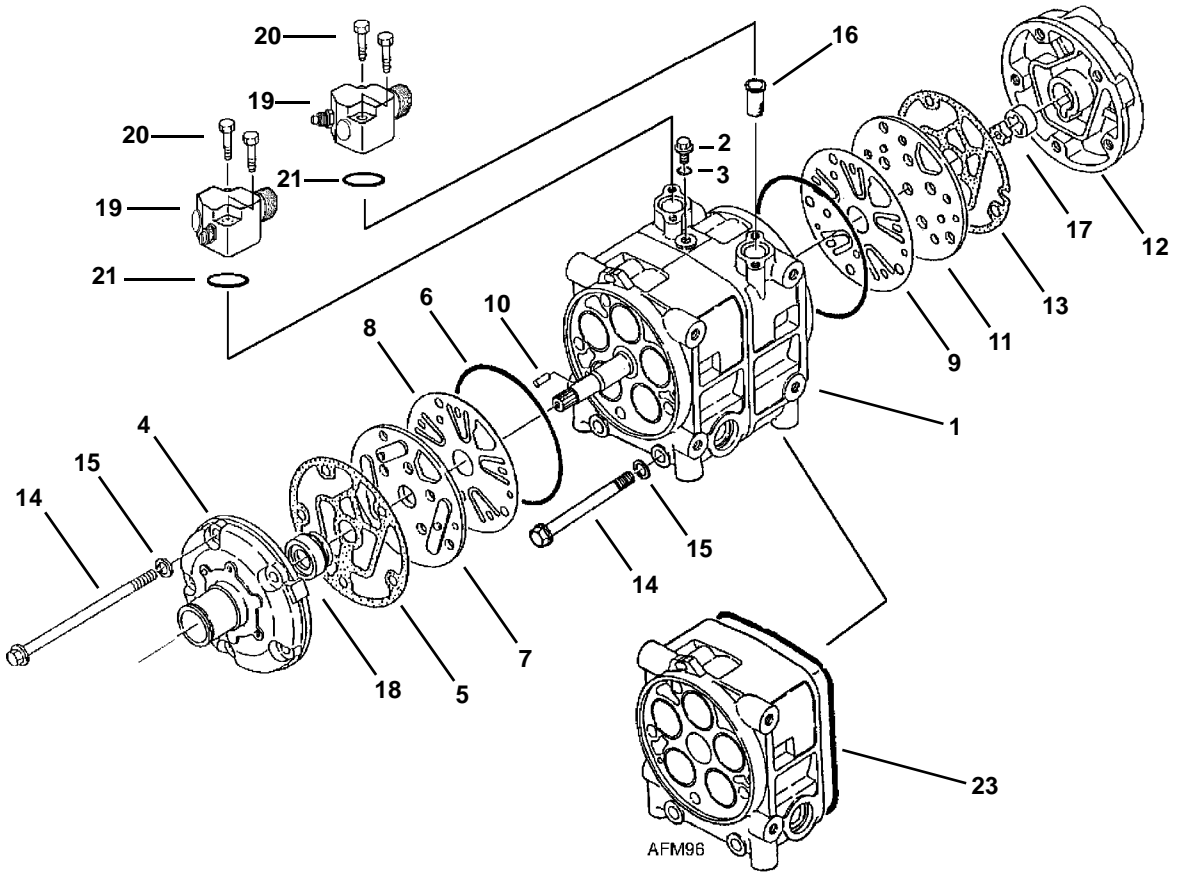

1.	Compressor Body	13.	Rear Gasket
2.	Oil Fill Plug	14.	Body Bolt
3.	Oil Plug O-ring	15.	Body Bolt Washer
4.	Front Cylinder Head	16.	Suction Screen
5.	Front Gasket	17.	Oil Pump
6.	Body O-ring	18.	Shaft Seal
7.	Front Valve Plate	19.	Manifold
8.	Front Valves	20.	Manifold Bolt
9.	Rear Valves	21.	Manifold O-ring
10.	Alignment Pin	22.	Sight Glass
11.	Rear Valve Plate	23.	Body Center O-ring
12.	Rear Cylinder Head		

Tightening Torques

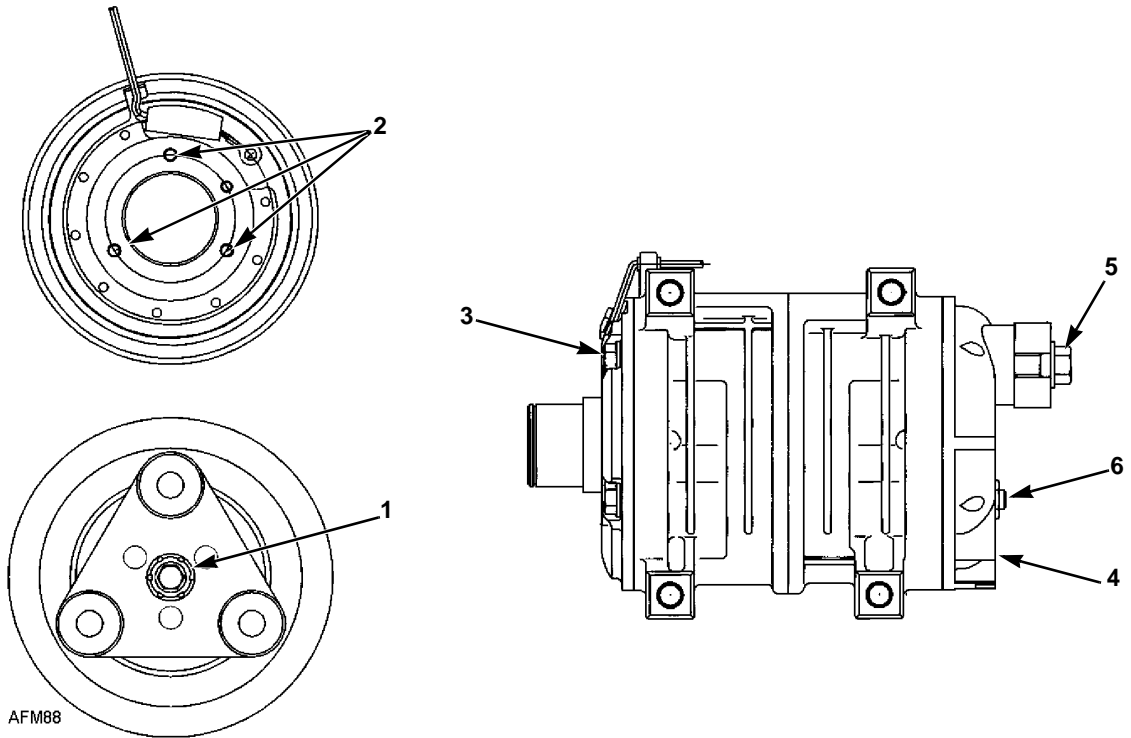

TM-08–TM-21 Thread Size and Torque Specifications

	Part	Thread Size	Tightening Torque
1.	Armature Bolt	M6 x 1.0	8.7 to 10.1 ft-lb (12 to 14 N•m)
2.	Field Coil Screw	M5 x 0.8	2.9 to 4.3 ft-lb (4 to 6 N•m)
3.	Body Bolt	M8 x 1.25	12.5 to 15.5 ft-lb (17 to 21 N•m)
4.	Oil Drain Plug	M8 x 1.25	9.4 to 10.8 ft-lb (13 to 15 N•m)
5.	Manifold Bolt	M8 x 1.25	14.5 to 17.3 ft-lb (20 to 24 N•m)
6.	Pressure Relief Valve	3/8-24 UNF	5.9 to 7.4 ft-lb (8 to 10 N•m)

TM-31 Thread Size and Torque Specifications

	Part	Thread Size	Tightening Torque
1.	Armature Bolt	M10 x 1.5	14.8 to 16.2 ft-lb (20 to 22 N•m)
2.	Field Coil Screws	M6 x 1	5.9 to 7.4 ft-lb (8 to 10 N•m)
3.	Body Bolts	M10 x 1.5	18.4 to 22.1 ft-lb (25 to 30 N•m)
4.	Oil Fill Plug	M8 x 1.25	10.3 to 11.8 ft-lb (14 to 16 N•m)
5.	Manifold Bolts	M8 x 1.25	14.8 to 16.2 ft-lb (20 to 22 N•m)

Compressor Maintenance: TM-08, TM-13, TM-15, TM-16, TM-21

Safety

⚠ *DANGER: Explosion Hazard! Do not throw or strike service cans. Do not handle the packing carton roughly. Do not use damaged or dented service cans. Store service cans out of reach of children.*

⚠ *DANGER: Explosion Hazard! Do not directly heat service cans or put them in water above 104 F (40 C). Do not put service cans on the engine or radiator when charging. If is necessary to heat service cans for charging in cold weather, use water below 104 F (40 C).*

⚠ *DANGER: Explosion Hazard! Do not store service cans in direct sunlight, near flame, or where temperature exceeds 104 F (40 C).*

⚠ *CAUTION: Do not put the charge valve in the warm water.*

Refrigerant Recovery

Avoid releasing refrigerant into the atmosphere. If you are removing refrigerant from an air conditioning system, use a refrigerant recovery unit.

Consult your recovery unit operators manual for hookup and operating procedures.



Figure 3: Recovery Unit – ICE No. 2590119

Compressor Handling

CAUTION: Do not strike or turn the compressor upside down. If the compressor is turned upside down, rotate it 5 to 6 times to circulate oil.

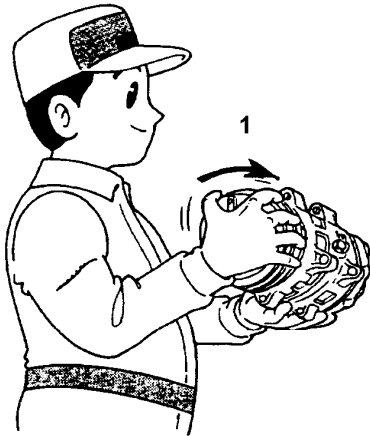

1.	Rotate Compressor Drive Shaft Several Times
----	---

Compressor Storage

Store new and rebuilt compressors:

- With the correct oil charge.
- Within the orientation range shown in Figure 4 on page 35. If the compressor sits outside that orientation for more than one minute, turn compressor manually (slowly) to clear oil from the cylinders.
- With a holding charge of refrigerant or nitrogen to a pressure of 7 to 21 psig (48 to 145 kPa). This protects internal parts from moisture and corrosion.

Compressor Removal

Operating Compressor

1. Perform the Oil Return Operation. See “Returning Oil to the Compressor” on page 37).
2. Recover the refrigerant. (See “Refrigerant Recovery” on page 33 and your system manual).
3. Remove the compressor from the system. Consult system manual if necessary.

Non-Operating Compressor

1. Perform the Refrigerant Recovery” (For more information, see “Refrigerant Recovery” on page 33.)
2. Remove the compressor from the system.

Compressor Installation

Installation Precautions

The new compressor has a specified quantity of compressor oil and nitrogen gas (N₂). When mounting the compressor, take the following steps:

- Loosen the discharge side connector cap. Gently release N₂ from compressor.

NOTE: This may be applicable to new compressors only.





CAUTION: Do not let oil escape.

- Manually rotate the drive shaft several times to distribute oil that has settled in the cylinders.



- Check and adjust the oil quantity before replacing the compressor. (see “Returning Oil to the Compressor” on page 37.) Follow system specifications.

Installation Position

Install the compressor within the range shown in Figure 4 below.

NOTE: The compressor has a pressure-feed lubrication system that cannot function if the compressor is installed outside this range.

When the compressor is mounted in its final position, turn it over manually approximately 10 revolutions before hooking the drive belt up to the pulley. If you do not do this, damage to the compressor valves can result from oil slugging. This is not covered under warranty!

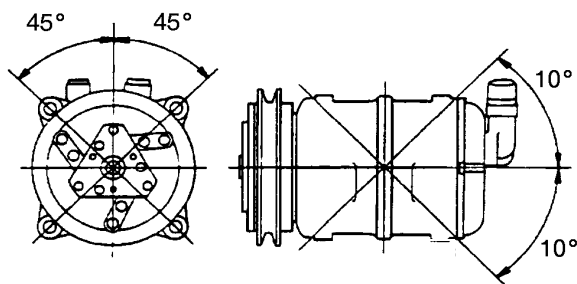
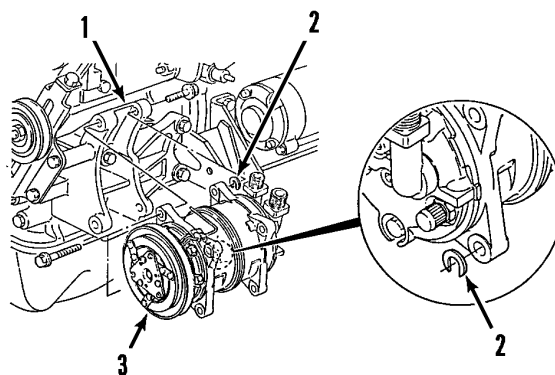

Figure 4: Compressor Installation Range

Mounting Compressors

- Range of Motion.** Verify the range of motion positioning at both extremes of the belt adjustment. Figure 4 shows the range of motion for the compressor.
- Clearance.** Clearance between the compressor mounting supports and bracket must be less than 0.004 inches (0.10 mm). Use shims as necessary to adjust this clearance (Shim Kit ICE No. 2570101). This reduces stress on the compressor.
- Pulley alignment.** Maintain correct pulley alignment for the drive belt.



1.	Bracket
2.	Shim ICE No. 257101
3.	Compressor

Figure 5: Shim Installation

Leak Testing the Compressor

After repairs and before installation, check a compressor for refrigerant leaks:

1. Install the discharge and suction caps on the connector.



2. Fill the compressor with refrigerant gas (same type used in the system) through the connector suction port. Raise the pressure to at least 70 psig (483 Kpa).
3. Check the compressor for leaks using a reliable leak detector.

NOTE: Use a leak tester being capable of detecting fluorine-based refrigerants.

Compressor Oil Procedures

Compressor Oil Caution Statements

⚠ CAUTION: Do not leave a system or oil containers open to the air longer than necessary. Compressor oils (POE and PAG) absorb moisture. Moisture-contaminated oil will damage system components.

⚠ CAUTION: Do not open refrigeration system unnecessarily. Doing so increases chances of contamination.

⚠ CAUTION: Discard used oil containers. These containers are hazardous.

⚠ CAUTION: Do not store PAG oil in plastic containers. PAG oil absorbs moisture through the plastic container.

Oil Charge Considerations

Most compressors come with a factory oil charge, which is listed on the rear label. This oil charge is for an average system that is already “wet.” The actual oil charge needed is application-specific, and may be different than the factory oil charge. Consult your application manual for the specific oil charge needed.

If you are replacing the compressor in an already “wet” system which has had no leaks, follow the procedure “Returning Oil to the Compressor” on page 37 to determine the oil charge needed for the new compressor.

If you are placing the compressor in a new, “un-wet” installation, use the amount of oil specified in the application manual. If no amount is specified, you will have to determine the amount experimentally. New systems require an additional oil charge to “wet” system components.

⚠ CAUTION: Not using the correct oil charge will damage your system.

Oil Type Considerations

Your compressor comes with an oil charge that may not be compatible with your system. Check system decals and operation manual for correct oil type.

If the oil charge in a new compressor is not compatible with your air conditioning system, remove and replace the oil.

Compressor Oil ICE No. 2560101 (1L PAG) is recommended for R-134a Systems.

⚠ CAUTION: Mixing incompatible oils will damage your system.

Oil Check Interval

Check and replenish or replace the compressor oil:

- At the start of the season
- Every 3,200 miles (5000 km) or every 5 months for commercial vehicles and vehicles that are in constant use
- When the compressor, evaporator, condenser, or receiver-drier is replaced
- When refrigerant has leaked from the system (for example, high pressure relief valve discharges)
- When gas or refrigerant leaks from the compressor
- When oil-related problems occur in the cooling cycle.

Oil Check Procedure

To check the compressor oil on an operating compressor, follow these steps:

- Return oil to the compressor
- Recover the refrigerant
- Remove the compressor
- Drain and inspect the oil.

Oil return, draining, and inspection procedures are described in this section. For compressor removal, see “Compressor Removal” on page 34. For refrigerant recovery, consult your system and recovery unit manuals.

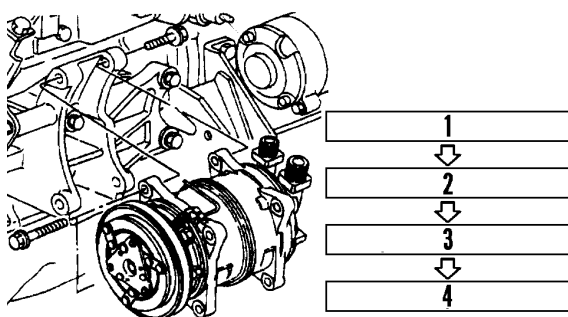

1.	Return Oil to Compressor
2.	Recover Refrigerant

Figure 6: Oil Check Procedure

3.	Compressor Removal
4.	Inspect the Oil

Figure 6: Oil Check Procedure

Returning Oil to the Compressor

During operation, oil circulates with refrigerant in a system. Before checking the oil, you must return as much as possible to the compressor. Not doing so will result in an incorrect measurement.

To return oil to the compressor:

1. Open the vehicles doors and windows to raise the interior air temperature to 75 to 80 degrees [25 to 27 C]. (The ambient air temperature should be above 85 degrees F (29 C). If not, partially block the condenser air flow to raise the compressor discharge pressure above 170 psig (1172 kPa).)
2. Run the A/C system at idle or high idle (800 and 1500 rpm) for approximately 20 minutes.
3. Turn the A/C system off.
4. Recover the refrigerant. See your system and recovery unit manuals for this procedure.
5. Remove the compressor from the system. See “Compressor Removal” on page 34.
6. Drain the oil as described below.

Draining the Oil

1. Perform the “Returning Oil to the Compressor” procedure above.
 2. Remove the drain plug from the compressor.
 3. Drain oil from the compressor drain plug and all other ports.
 4. Remove remaining oil through the discharge side connector by manually rotating the drive plate until all oil is removed.
 5. Measure oil in a measuring cylinder.
- NOTE:** See your application specifications for the correct oil amount.
6. Inspect oil for contamination (see “Checking Compressor Oil for Contamination” on page 38).

7. Replace the oil drain plug and tighten it per specifications (see “Tightening Torques” on page 31).
8. If necessary add oil. See “Adding Compressor Oil” on page 38.
9. Install the compressor (see “Compressor Installation” on page 34). Tighten bolts to the specified torque (see “Tightening Torques” on page 31).

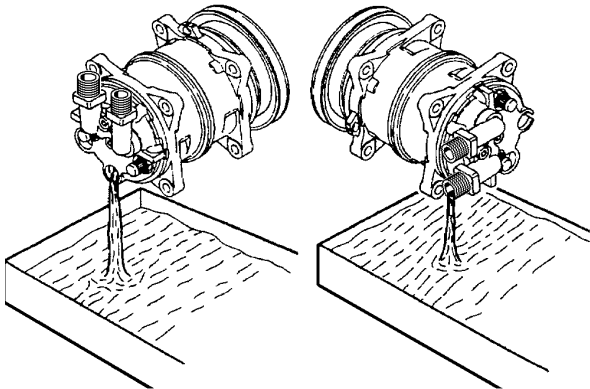

Figure 7: Draining Oil

Checking Compressor Oil for Contamination

Inspect extracted oil for the following:

- Dirt
- Color changed to red or black
- Presence of foreign substances, metal shavings, etc. in the oil.

Black oil indicates a severely contaminated system. To determine the extent of contamination, remove the filter-drier, then check if the black colored oil is present there. If so, flush the system. If flushing is required, use industry approved materials.

If the oil is clean at the filter-drier, install a new filter-drier and replace the oil with new oil. See “Adding Compressor Oil” below.

Adding Compressor Oil

To add oil:

1. Verify the correct oil type on the compressor label.

2. Verify the correct oil amount in your system specifications.
3. If oil is contaminated, replace old oil with new oil.
4. Add oil to the compressor through the suction port as shown in Figure 8.
5. Turn the shaft manually several times while adding oil to distribute oil evenly.

NOTE: Replace oil with fresh oil taken only from a sealed metal container.

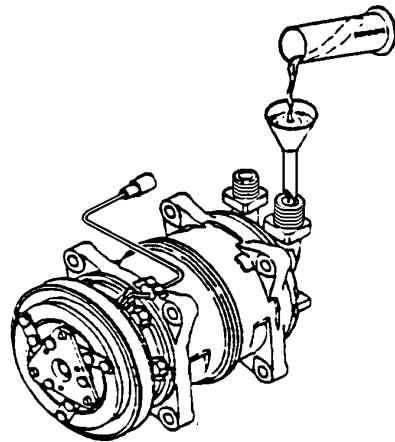

Figure 8: Typical Compressor Oil Fill Procedure

Clutch Procedures

For application guidelines, see “Clutch Application Guidelines” on page 13.

Clutch Run-In

Use this procedure to break in a new magnetic clutch.

1. Install the clutch on the compressor. For more information, see “Clutch Installation” on page 41.
2. Install the compressor on the engine. Charge the system. Operate the compressor by running the system.
3. Maintain the compressor speed at idle. Operate the A/C Switch through the on/off cycle at least 10 times (on for 10 seconds, off for 10 seconds).

Clutch Test

If the field coil lead wire is broken, replace the field coil. Check the amperage and voltage. The amperage range should be:

System	Amperage
12 Volt System	3.6 to 4.2
24 Volt System	1.8 to 2.1

Amperage indications:

- A very high amperage reading indicates a short within the field coil.
- No amperage reading indicates an open circuit in the winding.
- An intermittent or poor system ground results in lower voltage at the clutch. Check for a tight fit on the coil retaining snap ring, or for good ground at the coil retaining screws.

Clutch Removal

NOTE: See the Appendix for correct tools. Contact your local International Components Engineering Dealer for more information.

1. Remove the center armature bolt.



1.	Holder
----	--------

Figure 9: Remove Center Bolt

2. Remove the armature plate using the armature plate puller. Remove the shims from the armature shaft or the armature plate.



Figure 10: Remove Drive Plate

3. Remove the snap ring using external snap ring pliers. Remove the cover (if equipped).

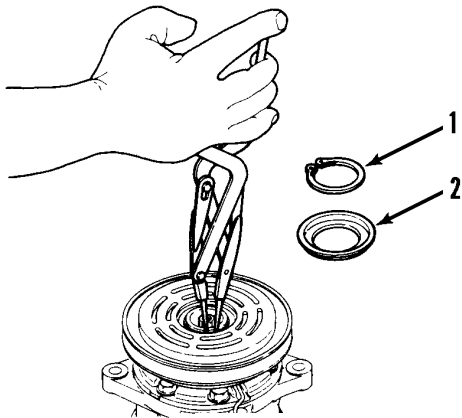

1.	Snap Ring
2.	Cover (If Equipped)

Figure 11: Remove Snap Ring and Cover

- Remove the pulley assembly using the pulley remover and the spacer positioned on the cylinder head hub.

CAUTION: To avoid damaging the pulley groove, hook the puller claws into, not under, the pulley groove.

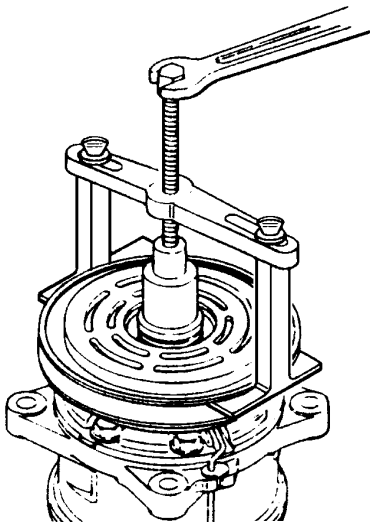

Figure 12: Remove Pulley

- Remove the coil lead wire from the holder on the top of the compressor.
- Remove the three screws that attach the coil to the compressor. Remove the coil.

NOTE: Do not hold the coil by the lead wire.

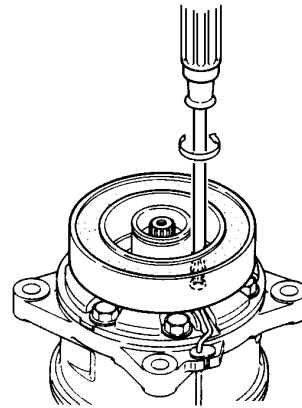

Figure 13: Remove Coil

Clutch Inspection

- Armature Plate**

If the contact surface is scorched, replace the armature plate and pulley.

- Pulley Assembly**

Inspect the appearance of the pulley assembly. If the pulley contact surface is excessively grooved due to slippage, replace the coil, pulley assembly, and armature plate. There should also be no foreign matter, such as oil or grit, lodged between the clutch plate and pulley. Clean these contact surfaces and the drive plate with a suitable solvent before installation.

- Coil**

Inspect the coil for a loose connector or cracked insulation. If the insulation is cracked, replace the coil. Repair or replace the wire or the connector if either is loose or damaged.

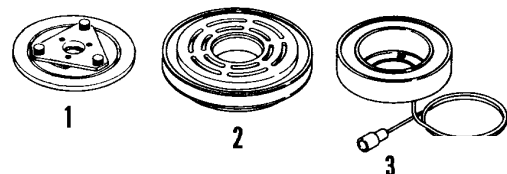

1.	Drive Plate
2.	Pulley Assemble
3.	Coil

Figure 14: Inspect Components

Clutch Installation

See “Clutch Inspection” before installing the clutch.

1. Install the coil on the compressor with the lead wire on top. Tighten the mounting screws to the specified torque. See “Tightening Torques” on page 31.
2. Install the lead wire in the wire holder on the compressor.

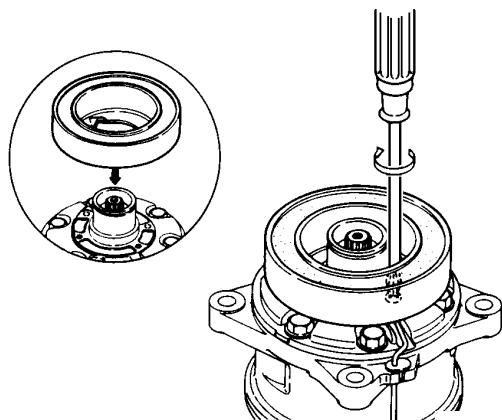

Figure 15: Install Coil

3. Install the pulley assembly using the Installer (ICE No. 2590118) and a hand press.

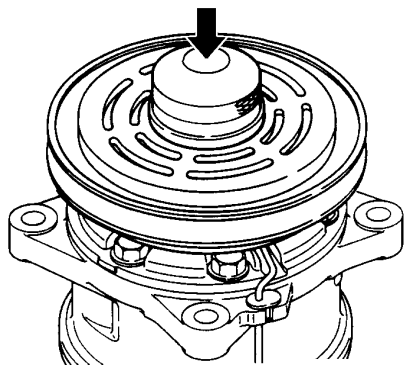

Figure 16: Install Pulley

4. Install the cover and the snap ring using external ring pliers.



1.	Snap Ring
2.	Cover (If Equipped)

Figure 17: Install Cover and Snap Ring (1)

NOTE: Install the snap ring with the chamfered inner edge outward (facing away from seal).

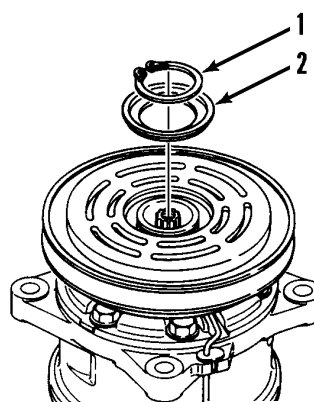

1.	Snap Ring
2.	Cover (If Equipped)

Figure 18: Install Cover and Snap Ring (2)

5. Install the driver plate on the drive shaft, together with the original shim(s). Press the drive plate down by hand.

NOTE: If replacement or additional shims are required, a clutch hardware kit is available (ICE No. 2530109).

6. Tighten the bolt to the specified torque using the Arbor puller (ICE No. 2590113) to prevent drive-plate rotation. See “Tightening Torques” on page 31.

After tightening the bolt, ensure that the pulley rotates smoothly.

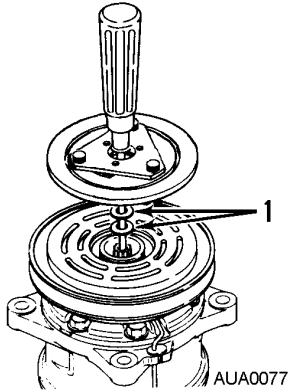

1.	Shims
----	-------

Figure 19: Install Shims and Drive Plate

7. Ensure that the clutch clearance is as specified. If necessary, adjust the clearance using shims.

NOTE: Adjusting shims are available in the clutch Hardware kit ICE No. 2530109.

NOTE: Specified clearance: 0.012 to 0.024 in. (0.3 to 0.6 mm).

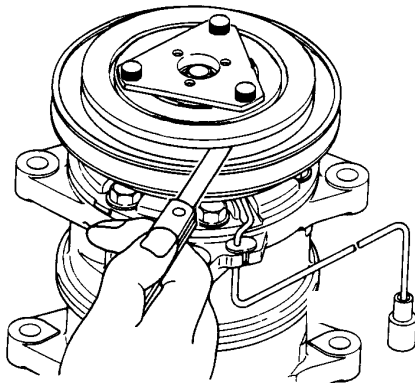

Figure 20: Check Clearance

Electrical Connection

1. Connect the lead wire to the electrical circuit.

NOTE: The stationary field is grounded at the factory. Connect the hot (lead) wire only.

2. Engage and disengage the clutch several times to check the engagement. The disc should snap firmly against the pulley.

Shaft Seal Procedures

Shaft Seal Removal

1. Remove the magnetic clutch assembly See “Clutch Removal” on page 39.
2. Use the seal remover (from the shaft seal kit ICE No. 2590114) to remove the shaft seal cover. Turn the seal remover to engage the hook on the seal remover with the hook on the shaft seal cover, then slowly pull the shaft seal cover out of the cylinder head (some models).
3. Remove the snap ring using internal snap ring pliers.



1.	Snap Ring
2.	Cover (When equipped)

NOTE: Do not reuse the shaft seal cover. Use a new shaft seal cover when reassembling a compressor.

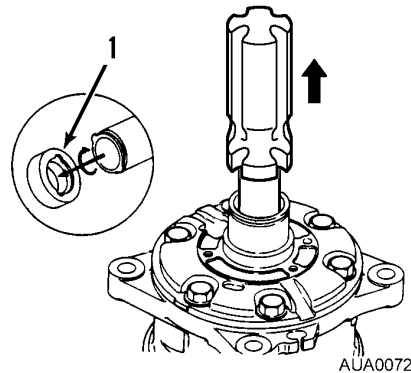

1.	Shaft Seal Cover (Some Models)
----	--------------------------------

Figure 21: Remove Shaft Seal Cover

- Use the seal remover (from the shaft seal kit ICE No. 259114) to remove the shaft seal. Turn the seal remover to engage the hook on the seal remover with the hook on the shaft seal, then slowly pull the shaft seal housing out of the cylinder head.

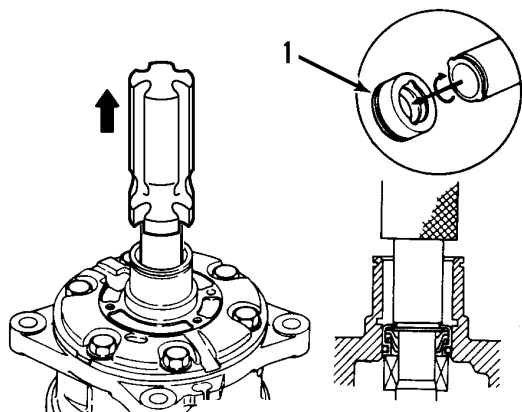

1.	Shaft Seal
----	------------

Figure 22: Remove Shaft Seal

Shaft Seal Inspection

Use a new shaft seal when reassembling the compressor. Inspect the lip of the new shaft seal for scratches and other damage. Make sure the shaft seal is free from lint and dirt.

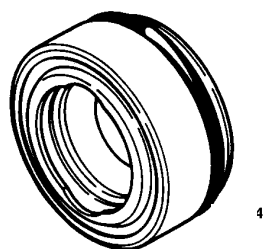

Figure 23: Inspect Shaft Seal

Shaft Seal Installation

Before installing a shaft seal inspect it carefully (see “Shaft Seal Inspection” above).

- Clean the seal section of the front cylinder head that holds shaft seal.
- Apply clean compressor oil to the new shaft seal and front cylinder head. If the slip surfaces are dirty, clean them with thinners,

dry the clean surfaces, and apply clean compressor oil. Use the same oil in the system.

- Place the seal guide (from the shaft seal kit ICE No. 2590114) on the end of the spline shaft.

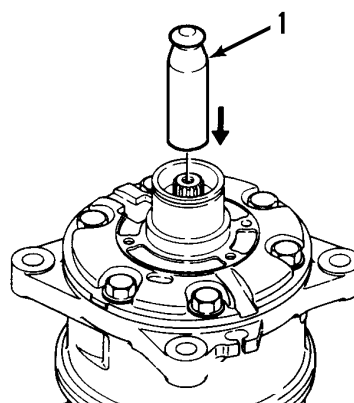

1.	Seal Guide
----	------------

Figure 24: Place Guide on Shaft

- Place the shaft seal over the seal guide. Slide the seal into the front cylinder head.

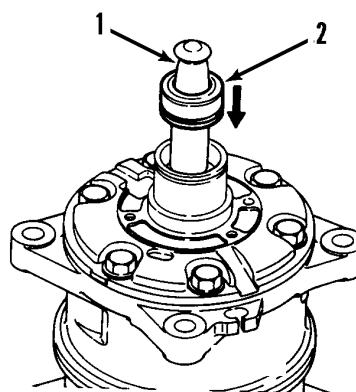

1.	Seal Guide
2.	Shaft Seal

Figure 25: Place Shaft Seal on Guide

- Use the seal installer (from the shaft seal kit ICE No. 2590116) to press the shaft seal into the cylinder head as far as possible.
- Remove the seal guide from the spline shaft.

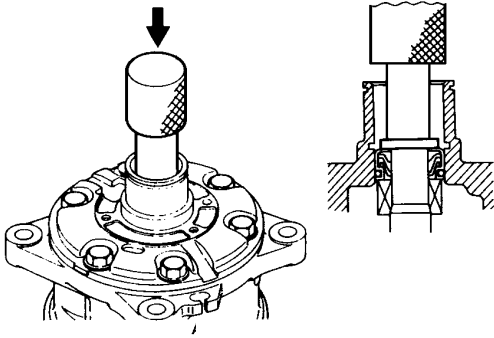

Figure 26: Press Seal Into Cylinder Head

7. Install the snap ring using internal snap ring pliers. Press the snap ring using the installing end of the remover until you hear a “click.”

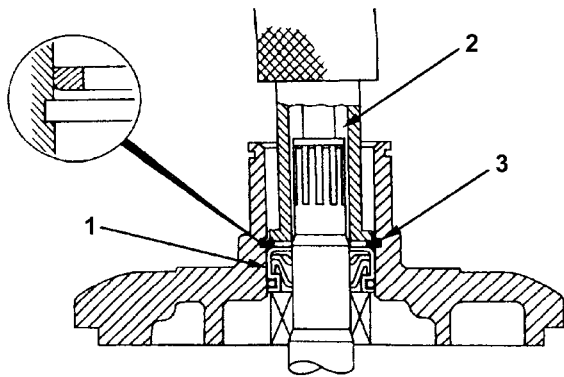

Figure 27: Shaft Seal Cover (When equipped)

3. Use the seal installer (from the shaft seal kit ICE No. 2590114) to press the shaft seal cover into the cylinder.
4. Remove the seal guide from the spline shaft.

NOTE: Position the shaft seal cover as shown in the illustration.

1.	Shaft Seal
2.	Guide
3.	Snap Ring

NOTE: Install the snap ring with the chamfered edge facing upward.

Shaft Seal Cover Installation (When Equipped)

1. Place the seal guide (from the shaft seal kit ICE No. 2590116) on the end of the shaft.
2. Place the shaft seal cover on the seal guide and slide the shaft seal cover into the cylinder head.

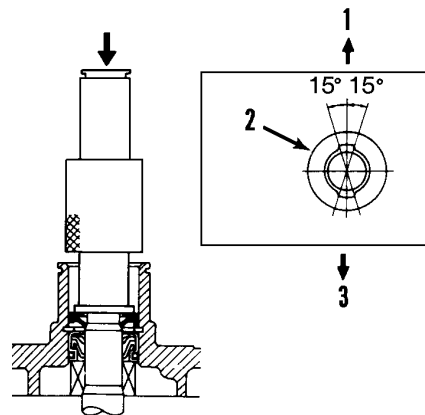

1.	Top
2.	Shaft Seal Cover
3.	Bottom

Figure 28: Shaft Seal Cover Position

Cylinder Head Procedures

Cylinder Head Disassembly—Front and Rear

1. Remove the magnetic clutch assembly, as outlined in “Clutch Removal” on page 39.
2. Remove the connector caps and the drain
Drain the oil. See “Draining the Oil” on page 37.

3. Remove the shaft seal cover and shaft seal.
See "Shaft Seal Removal" on page 42.
4. Remove the six body bolts securing the head using a socket wrench.

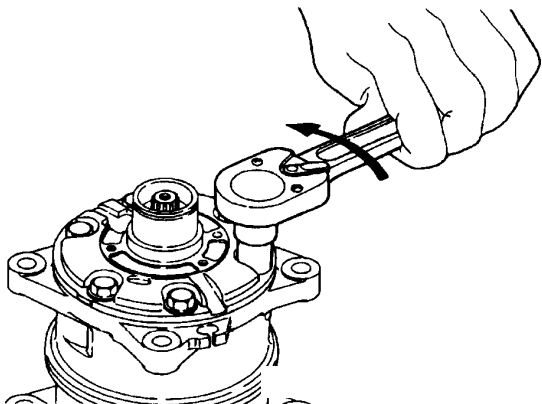

5. To remove the front cylinder head, alternately tap the two projections on the circumference of the front cylinder head with a screwdriver and a plastic mallet.

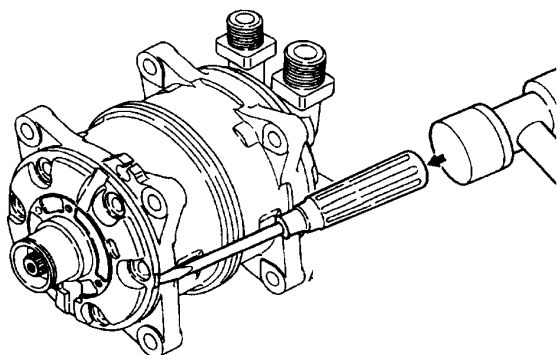

6. Remove the O-ring from the front cylinder head. Remove the gasket material from the front cylinder head.

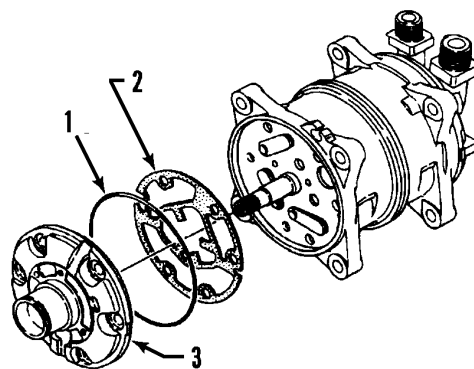

1.	O-ring
2.	Gasket
3.	Front Cylinder Head

7. Remove the valve plate and suction valve from the cylinder shaft assembly. Remove the gasket material from the valve plate.

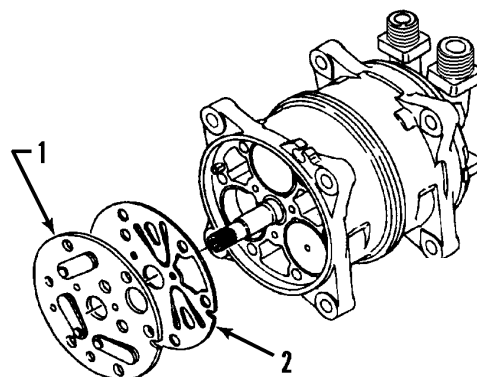

1.	Valve Plate
2.	Suction Valve

8. To remove the rear cylinder head, alternately tap the projections on the circumference of the rear head with a screwdriver and a plastic mallet.

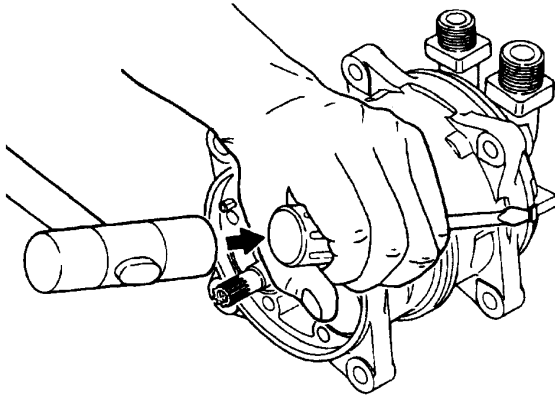

9. Remove the O-ring from the rear cylinder head. Remove the gasket material from the rear cylinder head.

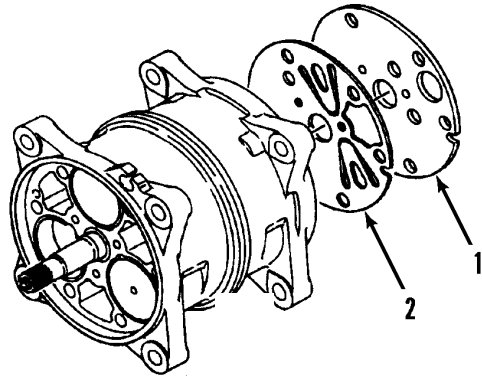

1.	Valve Plate
2.	Suction Valve

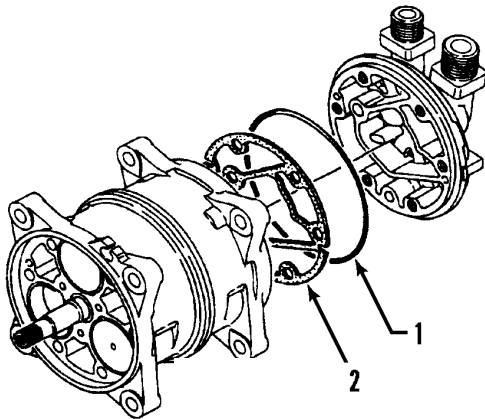

1.	O-ring
2.	Gasket

10. Remove the valve plate and suction valve from the cylinder shaft assembly. Remove the gasket material from the valve plate.

Cylinder Head Inspection

- Check the front and rear valve plates for scratched, bent, or damaged parts.
- Inspect both cylinder heads and both valve plate assemblies for nicks and burrs on the sealing surfaces. Clean or replace them if damaged.
- Ensure that all passages in the valve plate are unobstructed. If the cylinder head or valve plate is cracked, replace it.

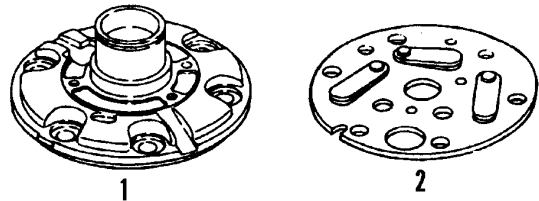

1.	Front Cylinder
2.	Valve Plate

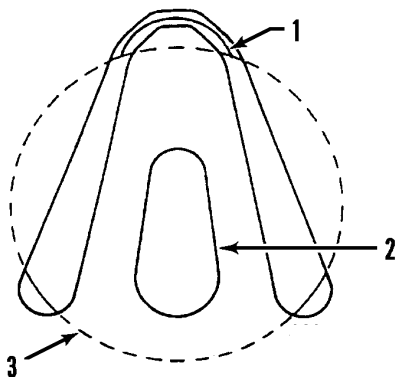

1.	Escape Groove
2.	Suction Valve
3.	Piston



2. Install the rear suction valve so that it aligns with the alignment pin.

CAUTION: *Ensure that the valve is aligned with the valve escape groove of each cylinder.*

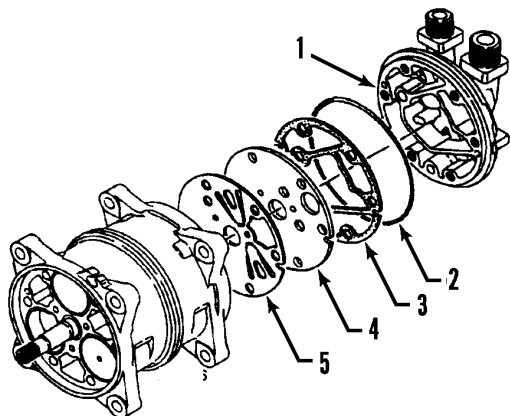

1.	Rear Cylinder Head
2.	O-ring
3.	Gasket
4.	Valve Plate
5.	Suction Valve

Cylinder Head Reassembly

Rear Cylinder Head

1. Place the cylinder shaft assembly on the bench with the rear side up.

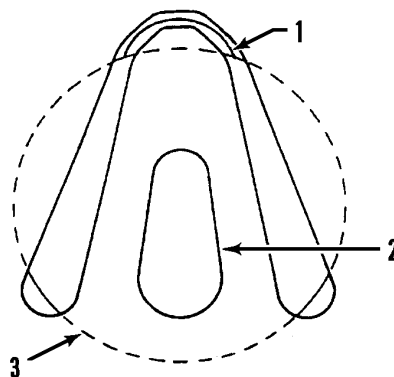

1.	Escape Groove
2.	Suction Valve
3.	Piston

3. Install the rear valve plate on the rear suction valve.

CAUTION: *Do not mistake the front valve plate for the rear valve plate.*

4. Coat the new gasket with clean compressor oil. Install it on the rear valve plate. Use the same oil used in the system.

5. Thinly coat the new O-ring with clean compressor oil (same type of oil that is used in the system). Install it on the rear cylinder head.
6. Install the rear cylinder head. If the rear cylinder head is difficult to install, tap the cylinder head lightly with a mallet.

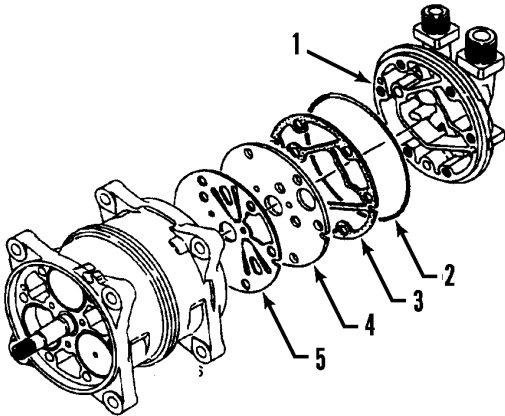

1.	Rear Cylinder Head
2.	O-ring
3.	Gasket
4.	Valve Plate
5.	Suction Valve

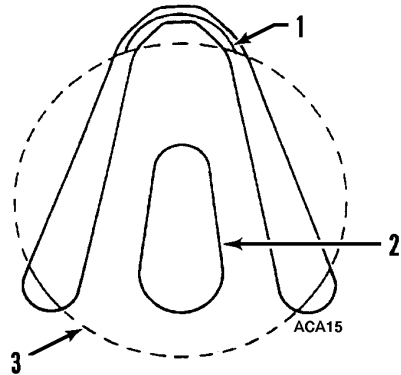

1.	Escape Groove
2.	Suction Valve
3.	Piston

⚠ CAUTION: *Ensure that the valve is aligned with the valve escape groove of each cylinder.*

3. Install the front valve plate on the front suction valve.

⚠ CAUTION: *Do not to mistake the rear valve plate for the front valve plate.*

Front Cylinder Head

1. Place the cylinder shaft assembly on the bench with the front side up.
2. Install the front suction valve so that it aligns with alignment pin.

4. Coat the new gasket with clean compressor oil (same oil used in the system). Install it on the front valve plate.
5. Thinly coat the new O-ring with clean compressor oil (same oil used in the system). Install it on the front cylinder head.
6. Install the front cylinder head. If the front cylinder head is difficult to install, tap the cylinder head lightly with a plastic mallet.

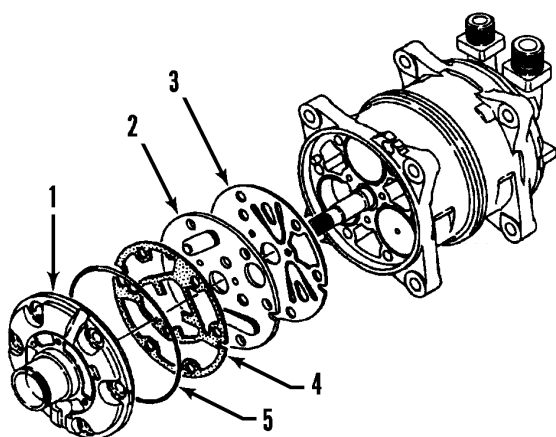

1.	Front Cylinder Head
2.	Valve Plate
3.	Suction Valve
4.	Gasket
5.	O-ring

NOTE: Air Gap—An incorrect air gap could cause erratic engagement or disengagement and/or clutch rattle. Check the air gap with a feeler gauge (0.012 to 0.024 in. [0.3 to 0.6 mm]). Adjust based on “Clutch Installation” on page 41.

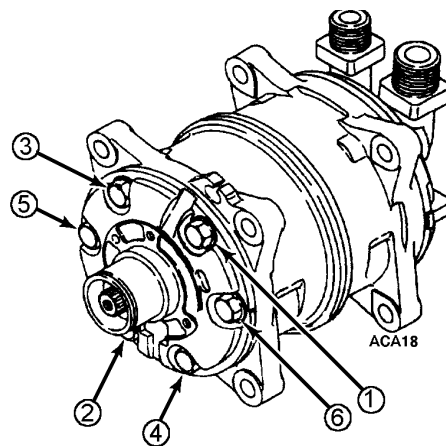
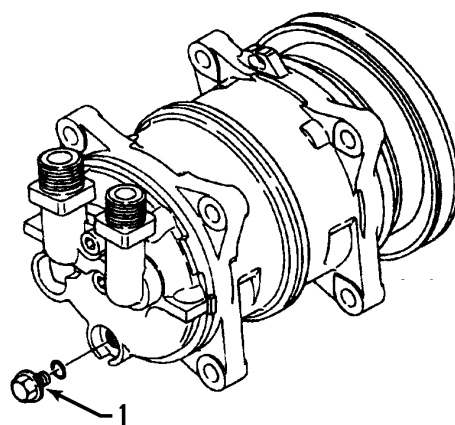

Figure 29: Tightening Sequence

7. Install new gaskets on the body bolts. Insert the six body bolts from the front cylinder head side and tighten them to the specified torque. Tighten each bolt gradually in three or more stages to ensure the specified torque (see “Tightening Torques” on page 31). Tighten bolts in the order shown in Figure 29 on page 49.

Turn the drive shaft 2 to 3 times manually to ensure that the shaft rotates smoothly.

8. Install the oil drain plug with a new O-ring, thinly coated with clean compressor oil, and tighten it to the specified torque. See “Tightening Torques” on page 31.
9. Fill the compressor with the specified amount of clean compressor oil. See “Adding Compressor Oil” on page 38.



1.	Drain Plug
----	------------

CAUTION: Check label to verify you are using the correct oil for the system.

10. Install the magnetic clutch (see “Clutch Installation” on page 41).
11. Leak test the system. See “Leak Testing the Compressor” on page 36.

Compressor Maintenance: TM-31

Safety

⚠ **DANGER: Explosion Hazard!** Do not throw or strike service cans. Do not handle the packing carton roughly. Do not use damaged or dented service cans. Store service cans out of reach of children.

⚠ **DANGER: Explosion Hazard!** Do not directly heat service cans or put them in water above 104 F (40 C). Do not put service cans on the engine or radiator when charging. If is necessary to heat service cans for charging in cold weather, use water below 104 F (40 C).

⚠ **DANGER: Explosion Hazard!** Do not store service cans in direct sunlight, near flame, or where temperature exceeds 104 F (40 C).

⚠ **CAUTION:** Do not put the charge valve in the warm water.

Refrigerant Recovery

Avoid the release of refrigerant into the atmosphere. If releasing refrigerant from an air conditioning system, use a refrigerant recovery unit to recover the refrigerant.

Consult your recovery unit operators manual for hookup and operating procedures.



Figure 30: Recovery Unit – ICE No. 2590119

Compressor Handling

CAUTION: Do not strike or turn the compressor upside down. If the compressor is turned upside down, rotate it 5 to 6 times to circulate oil.

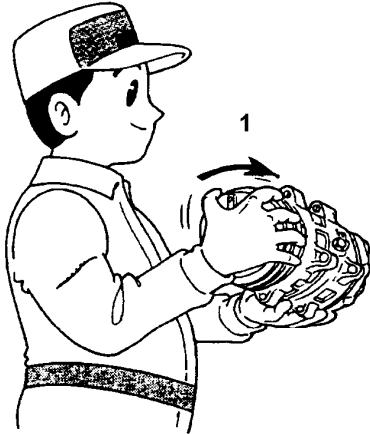

1.	Rotate Compressor's Magnetic Clutch 5 to 6 Times
----	--

Compressor Storage

Store new and rebuilt compressors:

- With the correct oil charge.
- Within the orientation range shown in Figure 31 on page 52. If the compressor sits outside that orientation for more than one minute, turn compressor manually (slowly) to clear oil from the cylinders.
- With a holding charge of refrigerant or nitrogen to a pressure of 7 to 21 psig (48 to 145 kPa). This protects internal parts from moisture and corrosion.

Compressor Removal

See "Compressor Removal" on page 34.

Compressor Installation



1.	Compressor Oil Sight Glass
----	----------------------------

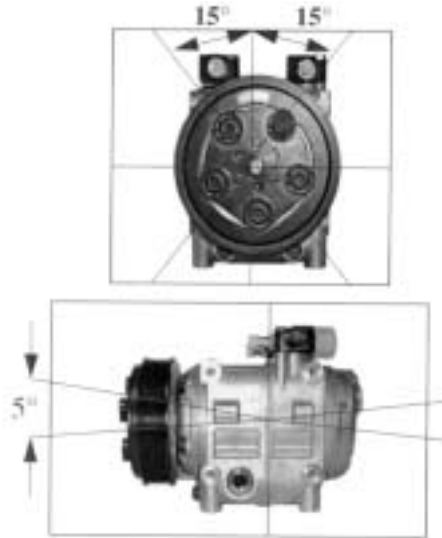

Figure 31: Inclusion Limit

NOTE: Inclination limit at installation must be within the range shown above.

NOTE: If mounting shims are required for installation, use Shim Kit (ICE No. 2570101).

Oil Procedures

NOTE: For Compressor Oil Caution Statements, Compressor Oil Charge Considerations, Compressor Oil Type Considerations, Oil Check Interval, Draining the Oil, and all Oil Check procedures, see “Compressor Oil Procedures” on page 36 in this manual.

To check oil level:

1. Return the oil to the compressor. See “Returning Oil to the Compressor” on page 37)
2. Use a flashlight to observe the compressor oil sight glass. Oil level should be approximately in the middle of the sight glass.

CAUTION: If compressor installation does not permit easy viewing, use a mirror to view the sight glass. Be careful of moving belts and pulleys.



1. Compressor Oil Sight Glass

Clutch Procedures

NOTE: See “Clutch Application Guidelines” on page 13 for application information.

Clutch Run-In

See “Clutch Run-In” on page 39.

Clutch Removal

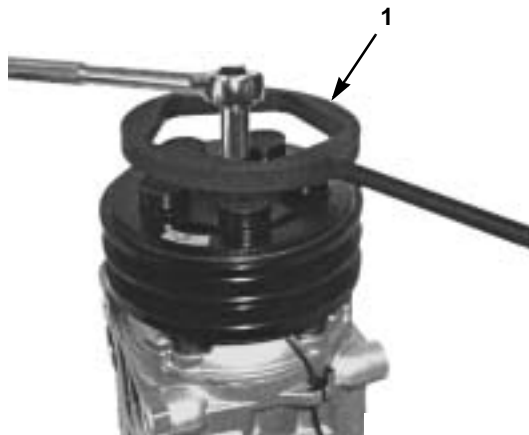

1. Drive Plate Holder -Typical

1. Remove the center bolt using a drive plate holder to prevent armature assembly rotation.



1. Drive Plate Puller

2. Remove the armature assembly using the drive plate puller. Remove the shims from the compressor driveshaft or armature assembly.

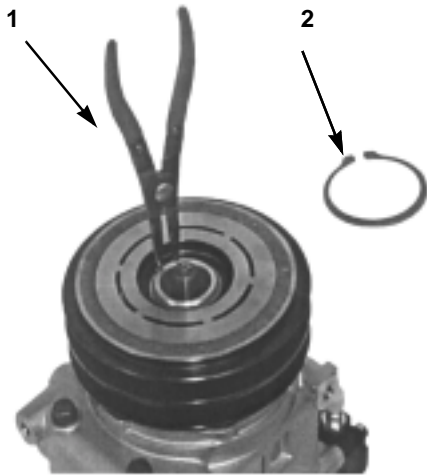

1.	Snap Ring Pliers ICE No. 2590117
2.	Snap Ring

3. Remove the snap ring using external snap ring pliers.

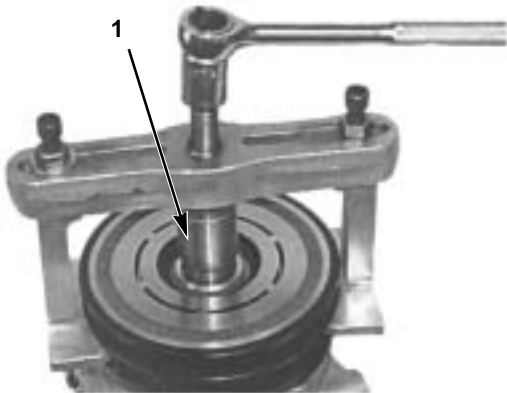

1.	Pulley Puller Center ICE No. 2590115
----	--------------------------------------

4. Position the pulley puller center on the end of the driveshaft. Remove the pulley assembly using a suitable pulley puller.

CAUTION: Clip the puller claws into the pulley groove to prevent pulley groove damage.



5. Remove the field coil by releasing the lead wire grommet from the compressor, then removing the three screws that secure the coil.

CAUTION: Do not hold the field coil by the harness.

Clutch Inspection

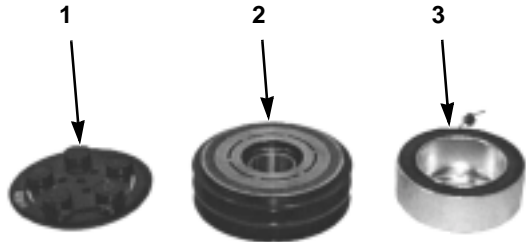

1.	Armature Assembly
2.	Pulley Assembly
3.	Field Coil

1. If the contact surface has been damaged by excessive heat, replace the armature and pulley.
2. Check the appearance of the pulley assembly. If the contact surface of the pulley is excessively grooved due to slippage, replace both the pulley and armature. Clean the contact surfaces of the pulley assembly with a suitable solvent before reinstallation.
3. Check the field coil for a loose connector or cracked insulation.

Clutch Installation



1. Install the field coil on the compressor (with the harness on top). Tighten the mounting screws to the specified torque.

Specified Torque: 6 to 7 ft-lbs (8 to 10 N•m)

2. Install the wire harness/strain relief.



1. Pulley Installer

3. Install the pulley assembly using the pulley installer and a hand press.
4. Install the snap ring using external snap ring pliers. Install the snap ring with the chamfered inner edge outward (facing away from the seal).

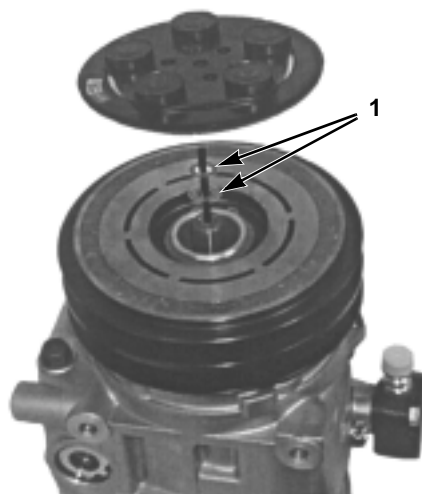

1. Shim(s)

5. Install the armature assembly on the driveshaft together with the original shim(s). Press the armature assembly down by hand.

NOTE: If required, additional shims are available. Use clutch hardware kit ICE No. 2530109.

6. Install the armature bolt and tighten the bolt to the specified torque using the drive plate holder to prevent armature assembly rotation.

Specified Torque: 14 to 16 ft-lbs (20 to 22 N•m)

CAUTION: After tightening the center bolt, check that the pulley rotates smoothly



Clutch Clearance: 0.012 t 0.024 in. (0.3 to 0.6 mm)

- Check that the clutch clearance is as specified. If necessary, adjust the clearance using shim(s).

NOTE: Clutch hardware kit is available (ICE No. 2530109).

Shaft Seal Procedures

Shaft Seal Removal

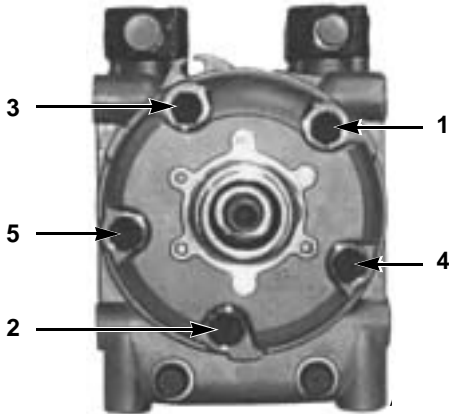
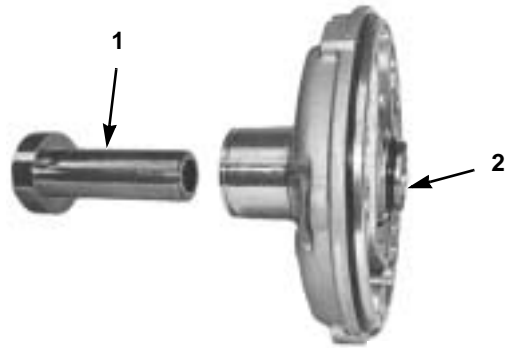

Figure 32: Torque Sequence

- Remove the magnetic clutch assembly See “Clutch Removal” on page 53.
- Remove the connector caps and oil drain plug. Drain the oil. See “Draining the Oil” on page 37.
- Remove the five through-bolts securing the head using a hexagon wrench.



- Remove the front cylinder head by tapping the three projections on the circumference of the front cylinder head with a screwdriver (flat head) and a plastic or rubber mallet.



1.	Remover - Shaft Seal Kit ICE No. 2590114
2.	Shaft Seal

- Remove the shaft seal, pushing the remover until the shaft seal is pushed out the back of the head.

Shaft Seal Installation

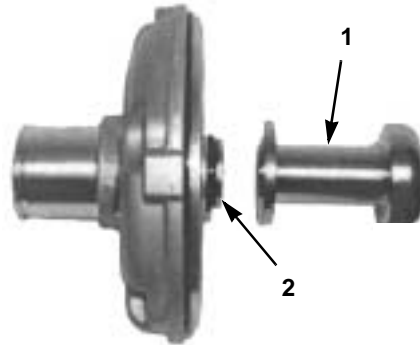

1.	Installer- ICE No. 2590117
2.	Shaft Seal

- Clean the sealed section of the front cylinder head.
- Apply clean compressor oil to the new shaft seal.



CAUTION: Use same oil type in the system.

- Insert the shaft seal as far as possible into the front cylinder head using the installer.

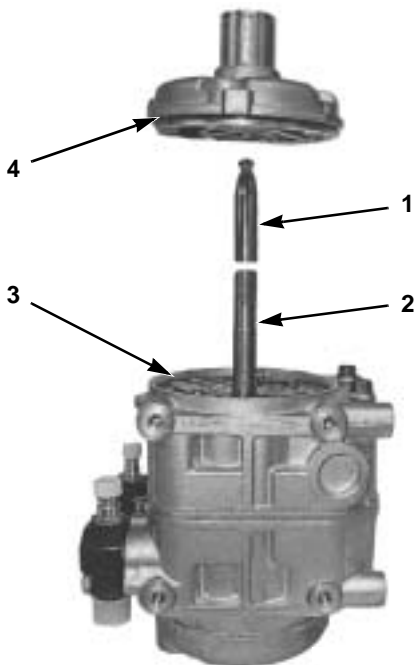

1.	Guide
2.	Shaft
3.	Gasket
4.	O-ring

- Thinly coat the new O-ring and gasket with clean compressor oil. Use the same oil used in the system.
- Fit the guide onto the end of the drive shaft. Install the front cylinder head. If the front cylinder head is difficult to install, tap the cylinder head lightly with a plastic or rubber mallet.



- Mount the new gaskets on the through-bolts.
- Insert the five through-bolts from the front cylinder head side and tighten them to the specified torque.

NOTE: Tighten the bolts in the order shown in the torque sequence photo. See “Torque Sequence” on page 56..

Specified Torque: 18.4-22.1 ft-lbs (25 to 30 N•m)

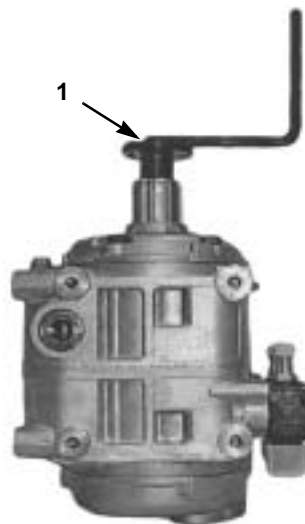

1.	Handle
----	--------

- Turn the drive shaft two or three times manually to ensure that the shaft rotates smoothly.
- Fill the compressor with the specified amount of clean compressor oil through the oil filler. Tighten the oil filler plug to the specified torque.

Specified Torque: 10-12 ft-lbs (14 to 16 N•m)

- Install the magnetic clutch. See “Clutch Installation” on page 55.
- Do a clutch run-in (see “Clutch Run-In” on page 39) and leak test (see “Leak Testing the Compressor” on page 36).

Appendix – Tools and Kits

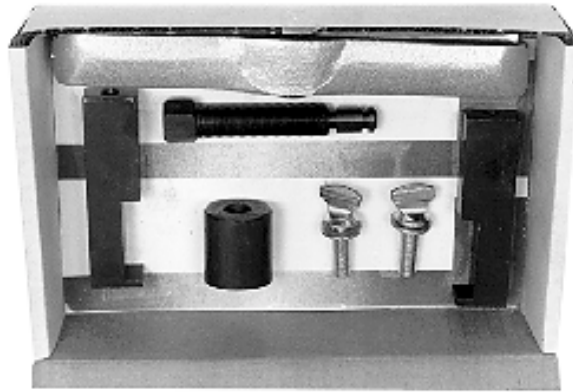

Clutch Remover – ICE No. 2590115

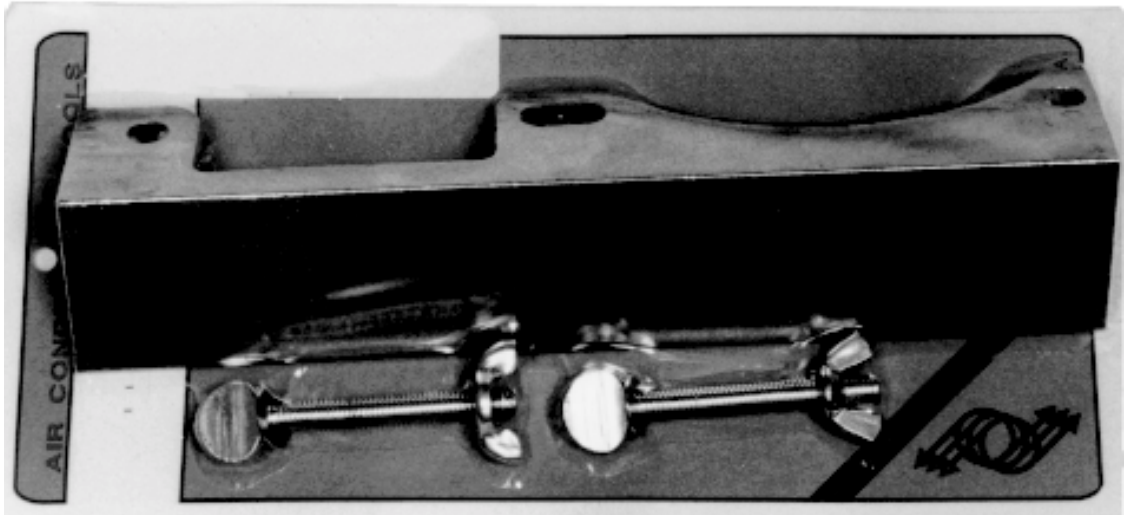

Compressor Holder – ICE No. 2590116



Clutch Installation Kit – ICE No. 2590118



Shaft Seal Kit – ICE No. 2590114



Snap Ring Pliers – ICE No. 2590117



Clutch Hardware Kit – ICE No. 2530109



Shim Kit – ICE No. 2570101



*Customer Service: Phone 952-886-6088
Visit our Web site at www.intl-comp.com
or contact our Customer Service at
952-886-6088
Fax: 952-886-6099*

