

GeoMax Zenith25 Series User Manual



Version 1.0

Introduction

Validity of this manual





This manual applies to the Zenith25 GNSS instrument with the models GSM (without TNC plug) and GSM/UHF.



This manual contains important safety directions as well as instructions for setting up the product and operating it. Refer to "1 Safety Directions" for further information. Read carefully through the User Manual before you switch on the product.

Symbols

The symbols used in this manual have the following meanings:

Type	Description
 DANGER	Indicates an imminently hazardous situation which, if not avoided, will result in death or serious injury.
 WARNING	Indicates a potentially hazardous situation or an unintended use which, if not avoided, could result in death or serious injury.
 CAUTION	Indicates a potentially hazardous situation or an unintended use which, if not avoided, may result in minor or moderate injury.
NOTICE	Indicates a potentially hazardous situation or an unintended use which, if not avoided, may result in appreciable material, financial and environmental damage.
	Important paragraphs which must be adhered to in practice as they enable the product to be used in a technically correct and efficient manner.

Trademarks

- Windows is a registered trademark of Microsoft Corporation in the United States and other countries
 - *Bluetooth*[®] is a registered trademark of Bluetooth SIG, Inc.
 - microSD Logo is a trademark of SD-3C, LLC.
- All other trademarks are the property of their respective owners.

Table of Contents

In this manual	Chapter	Page
1	Safety Directions	4
1.1	General Introduction	4
1.2	Definition of Use	4
1.3	Limits of Use	4
1.4	Responsibilities	4
1.5	Hazards of Use	5
1.6	Electromagnetic Compatibility EMC	7
1.7	FCC Statement, Applicable in U.S.	8
1.8	Conformity to National Regulations	9
2	Description of the System	10
2.1	System Components	10
2.2	Container Contents	10
2.3	System Concept	11
2.3.1	Software Concept	11
2.3.2	Power Concept	11
2.3.3	Data Storage Concept	11
2.4	Instrument Components	11
2.5	Pin Assignments	11
2.6	The Mechanical Reference Plane, MRP	12
3	User Interface	13
3.1	Keyboard	13
3.2	LED Indicators	14
4	Operation	15
4.1	Guidelines for Correct Results with GNSS Surveys	15
4.2	Equipment Setup	15
4.2.1	Setting up as a Real-Time Base	15
4.2.2	Setting up as a Post-Processing Base	16
4.2.3	Setting Up as a Real-Time Rover	17
4.2.4	Fixing the handheld to a holder and pole	17
4.2.5	Connecting to a Personal Computer	18
4.3	Batteries	18
4.3.1	Operating Principles	18
4.3.2	Inserting and removing the Battery	19
4.4	Inserting a microSD card	20
4.5	Inserting a SIM card	21
5	Care and Transport	22
5.1	Transport	22
5.2	Storage	22
5.3	Cleaning and Drying	22
6	Technical Data	23
6.1	Technical Data	23
6.1.1	Tracking Characteristics	23
6.1.2	Accuracy	23
6.1.3	GNSS antenna specifications	23
6.1.4	Internal devices	23
6.1.5	Technical Data	23
6.1.6	Environmental specifications	24
	Index	25

1 Safety Directions

1.1 General Introduction

Description The following directions enable the person responsible for the product, and the person who actually uses the equipment, to anticipate and avoid operational hazards.

The person responsible for the product must ensure that all users understand these directions and adhere to them.

1.2 Definition of Use

Intended use

- Computing with software.
- Recording measurements.
- Carrying out measurement tasks using various GNSS measuring techniques.
- Recording GNSS and point related data.
- Remote control of product.
- Data communication with external appliances.
- Measuring raw data and computing coordinates using carrier phase and code signal from GNSS satellites.

Reasonably foreseeable misuse

- Use of the product without instruction.
- Use outside of the intended use and limits.
- Disabling safety systems.
- Removal of hazard notices.
- Opening the product using tools, for example screwdriver, unless this is permitted for certain functions.
- Modification or conversion of the product.
- Use after misappropriation.
- Use of products with recognisable damages or defects.
- Use with accessories from other manufacturers without the prior explicit approval of GeoMax.
- Inadequate safeguards at the working site.
- Controlling of machines, moving objects or similar monitoring application without additional control- and safety installations.

1.3 Limits of Use

Environment Suitable for use in an atmosphere appropriate for permanent human habitation: not suitable for use in aggressive or explosive environments.



DANGER

Local safety authorities and safety experts must be contacted before working in hazardous areas, or close to electrical installations or similar situations by the person in charge of the product.

1.4 Responsibilities

Manufacturer of the product GeoMax AG, CH-9443 Widnau, hereinafter referred to as GeoMax, is responsible for supplying the product, including the user manual and original accessories, in a safe condition.

Person responsible for the product The person responsible for the product has the following duties:

- To understand the safety instructions on the product and the instructions in the user manual.
- To ensure that it is used in accordance with the instructions.
- To be familiar with local regulations relating to safety and accident prevention.
- To inform GeoMax immediately if the product and the application becomes unsafe.
- To ensure that the national laws, regulations and conditions for the operation of e.g. radio transmitters, lasers are respected.

	DANGER	<p>Because of the risk of electrocution, it is dangerous to use poles and extensions in the vicinity of electrical installations such as power cables or electrical railways.</p> <p>Precautions: Keep at a safe distance from electrical installations. If it is essential to work in this environment, first contact the safety authorities responsible for the electrical installations and follow their instructions.</p>
	WARNING	<p>During dynamic applications, for example stakeout procedures there is a danger of accidents occurring if the user does not pay attention to the environmental conditions around, for example obstacles, excavations or traffic.</p> <p>Precautions: The person responsible for the product must make all users fully aware of the existing dangers.</p>
	WARNING	<p>Inadequate securing of the working site can lead to dangerous situations, for example in traffic, on building sites, and at industrial installations.</p> <p>Precautions: Always ensure that the working site is adequately secured. Adhere to the regulations governing safety and accident prevention and road traffic.</p>
	CAUTION	<p>If the accessories used with the product are not properly secured and the product is subjected to mechanical shock, for example blows or falling, the product may be damaged or people can sustain injury.</p> <p>Precautions: When setting-up the product, make sure that the accessories are correctly adapted, fitted, secured, and locked in position. Avoid subjecting the product to mechanical stress.</p>
	WARNING	<p>If the product is used with accessories, for example masts, staffs, poles, you may increase the risk of being struck by lightning.</p> <p>Precautions: Do not use the product in a thunderstorm.</p>
	DANGER	<p>If the product is used with accessories, for example on masts, staffs, poles, you may increase the risk of being struck by lightning. Danger from high voltages also exists near power lines. Lightning, voltage peaks, or the touching of power lines can cause damage, injury and death.</p> <p>Precautions:</p> <ul style="list-style-type: none"> • Do not use the product in a thunderstorm as you can increase the risk of being struck by lightning. • Be sure to remain at a safe distance from electrical installations. Do not use the product directly under or close to power lines. If it is essential to work in such an environment contact the safety authorities responsible for electrical installations and follow their instructions. • If the product has to be permanently mounted in an exposed location, it is advisable to provide a lightning conductor system. A suggestion on how to design a lightning conductor for the product is given below. Always follow the regulations in force in your country regarding grounding antennas and masts. These installations must be carried out by an authorised specialist. • To prevent damages due to indirect lightning strikes (voltage spikes) cables, for example for antenna, power source or modem should be protected with appropriate protection elements, like a lightning arrester. These installations must be carried out by an authorised specialist. • If there is a risk of a thunderstorm, or if the equipment is to remain unused and unattended for a long period, protect your product additionally by unplugging all systems components and disconnecting all connecting cables and supply cables, for example, instrument - antenna.

Lightning conductors

Suggestion for design of a lightning conductor for a GNSS system:

1) On non-metallic structures

Protection by air terminals is recommended. An air terminal is a pointed solid or tubular rod of conducting material with proper mounting and connection to a conductor. The position of four air terminals can be uniformly distributed around the antenna at a distance equal to the height of the air terminal.

The air terminal diameter should be 12 mm for copper or 15 mm for aluminium. The height of the air terminals should be 25 cm to 50 cm. All air terminals should be connected to the down conductors. The diameter of the air terminal should be kept to a minimum to reduce GNSS signal shading.

2) On metallic structures

Protection is as described for non-metallic structures, but the air terminals can be connected directly to the conducting structure without the need for down conductors.

Air terminal arrangement, plan view

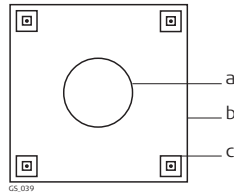

- a) Antenna
- b) Support structure
- c) Air terminal

Grounding the instrument/antenna

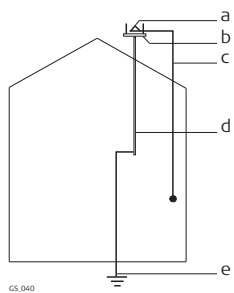

- a) Antenna
- b) Lightning conductor array
- c) Antenna/instrument connection
- d) Metallic mast
- e) Connection to earth



CAUTION

During the transport, shipping or disposal of batteries it is possible for inappropriate mechanical influences to constitute a fire hazard.

Precautions:

Before shipping the product or disposing of it, discharge the batteries by running the product until they are flat.

When transporting or shipping batteries, the person in charge of the product must ensure that the applicable national and international rules and regulations are observed. Before transportation or shipping contact your local passenger or freight transport company.



WARNING

High mechanical stress, high ambient temperatures or immersion into fluids can cause leakage, fire or explosions of the batteries.

Precautions:

Protect the batteries from mechanical influences and high ambient temperatures. Do not drop or immerse batteries into fluids.



WARNING

If battery terminals are short circuited e.g. by coming in contact with jewellery, keys, metalized paper or other metals, the battery can overheat and cause injury or fire, for example by storing or transporting in pockets.

Precautions:

Make sure that the battery terminals do not come into contact with metallic objects.



WARNING

Incorrect fastening of the external antenna to vehicles or transporters poses the risk of the equipment being broken by mechanical influence, vibration or airstream. This may result in accident and physical injury.

Precautions:

Attach the external antenna professionally. The external antenna must be secured additionally, for example by use of a safety cord. Ensure that the mounting device is correctly mounted and able to carry the weight of the external antenna (>1 kg) safely.

WARNING

If the product is improperly disposed of, the following can happen:

- If polymer parts are burnt, poisonous gases are produced which may impair health.
- If batteries are damaged or are heated strongly, they can explode and cause poisoning, burning, corrosion or environmental contamination.
- By disposing of the product irresponsibly you may enable unauthorised persons to use it in contravention of the regulations, exposing themselves and third parties to the risk of severe injury and rendering the environment liable to contamination.

Precautions:

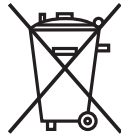

The product must not be disposed with household waste.
 Dispose of the product appropriately in accordance with the national regulations in force in your country.
 Always prevent access to the product by unauthorised personnel.

Product-specific treatment and waste management information is available from GeoMax AG.

WARNING

Only GeoMax authorised service workshops are entitled to repair these products.

1.6

Electromagnetic Compatibility EMC

Description

The term Electromagnetic Compatibility is taken to mean the capability of the product to function smoothly in an environment where electromagnetic radiation and electrostatic discharges are present, and without causing electromagnetic disturbances to other equipment.

WARNING

Electromagnetic radiation can cause disturbances in other equipment.

Although the product meets the strict regulations and standards which are in force in this respect, GeoMax cannot completely exclude the possibility that other equipment may be disturbed.

CAUTION

There is a risk that disturbances may be caused in other equipment if the product is used with accessories from other manufacturers, for example field computers, personal computers or other electronic equipment, non-standard cables or external batteries.

Precautions:

Use only the equipment and accessories recommended by GeoMax. When combined with the product, they meet the strict requirements stipulated by the guidelines and standards. When using computers or other electronic equipment, pay attention to the information about electromagnetic compatibility provided by the manufacturer.

CAUTION

Disturbances caused by electromagnetic radiation can result in erroneous measurements. Although the product meets the strict regulations and standards which are in force in this respect, GeoMax cannot completely exclude the possibility that the product may be disturbed by intense electromagnetic radiation, for example, near radio transmitters, two-way radios or diesel generators.

Precautions:

Check the plausibility of results obtained under these conditions.

CAUTION

If the product is operated with connecting cables attached at only one of their two ends, for example external supply cables, interface cables, the permitted level of electromagnetic radiation may be exceeded and the correct functioning of other products may be impaired.

Precautions:

While the product is in use, connecting cables, for example product to external battery, product to computer, must be connected at both ends.

Radios or digital cellular phones

Use of product with radio or digital cellular phone devices:

WARNING

Electromagnetic fields can cause disturbances in other equipment, in installations, in medical devices, for example pacemakers or hearing aids and in aircraft. It can also affect humans and animals.

Precautions:

Although the product meets the strict regulations and standards which are in force in this respect, GeoMax cannot completely exclude the possibility that other equipment can be disturbed or that humans or animals can be affected.

- Do not operate the product with radio or digital cellular phone devices in the vicinity of filling stations or chemical installations, or in other areas where an explosion hazard exists.
- Do not operate the product with radio or digital cellular phone devices near to medical equipment.
- Do not operate the product with radio or digital cellular phone devices in aircraft.



The greyed paragraph below is only applicable for products without radio.

WARNING

This equipment has been tested and found to comply with the limits for a Class B digital device, pursuant to part 15 of the FCC rules.

These limits are designed to provide reasonable protection against harmful interference in a residential installation.

This equipment generates, uses and can radiate radio frequency energy and, if not installed and used in accordance with the instructions, may cause harmful interference to radio communications. However, there is no guarantee that interference will not occur in a particular installation.

If this equipment does cause harmful interference to radio or television reception, which can be determined by turning the equipment off and on, the user is encouraged to try to correct the interference by one or more of the following measures:

- Reorient or relocate the receiving antenna.
- Increase the separation between the equipment and the receiver.
- Connect the equipment into an outlet on a circuit different from that to which the receiver is connected.
- Consult the dealer or an experienced radio/TV technician for help.

WARNING

Changes or modifications not expressly approved by GeoMax for compliance could void the user's authority to operate the equipment.

Labelling Zenith25



Labelling internal battery ZBA200

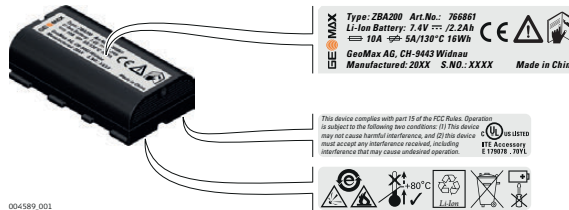

WARNING

This Class (B) digital apparatus complies with Canadian ICES-003.
Cet appareil numérique de la classe (B) est conforme à la norme NMB-003 du Canada.

Conformity to national regulations

- FCC Part 15 (applicable in US)
- Hereby, GeoMax AG, declares that the product Zenith25 is in compliance with the essential requirements and other relevant provisions of Directive 1999/5/EC and other applicable European Directives. The declaration of conformity is available from GeoMax AG.
- This Class 2 equipment may be operated in: AT, BE, CY, CZ, DK, EE, FI, FR, DE, GR, HU, IE, IT, LV, LT, LU, MT, NL, PL, PT, SK, SI, ES, SE, GB, IS, LI, NO, CH, BG, RO and TR.



Class 2 equipment according European Directive 1999/5/EC (R&TTE) for which following EEA Member States apply restrictions on the placing on the market or on the putting into service or require authorisation for use:

- France
- Italy
- Norway (if used in the geographical area within a radius of 20km from the centre of Ny-Ålesund)
- The conformity for countries with other national regulations not covered by the FCC part 15 or European directive 1999/5/EC has to be approved prior to use and operation.

Frequency band

Type	Frequency band (MHz)
GNSS receiver:	GPS L1: 1575.42 GPS L2: 1227.60 GLONASS L1: 1602.5625 - 1611.50 GLONASS L2: 1246.4375 - 1254.30
Bluetooth:	2402 - 2480
Radio:	406 - 480
2G GSM:	Quad-Band EGSM 850 / 900 / 1800 / 1900 GPRS multi-slot class 10

Output power

Type	Output power [mW]
GNSS:	Receive only
Bluetooth:	5
Radio:	500, 1000
2G GSM EGSM850/900:	2000
2G GSM GSM1800/1900:	1000

Antenna

Type	Antenna	Gain [dBi]
GNSS:	Internal GNSS antenna element (receive only)	33
Bluetooth:	Internal Microstrip antenna	2 max.
UHF:	Detachable $\lambda/2$ antenna	4 max.
2G GSM:	Integrated antenna	1 max. @ 850 / 900 (preliminary) 4 max. @ 1800 / 1900 (preliminary)

2 Description of the System

2.1 System Components

Main components

Component	Description
Instrument	A GNSS receiver with integrated communication devices.
Getac	A multi-purpose handheld enabling the control of GeoMax instruments.
GeoMax Geo Office	An office software used for the processing of raw GNSS data.

2.2 Container Contents

Container for Zenith25 instrument and accessories part 1 of 2

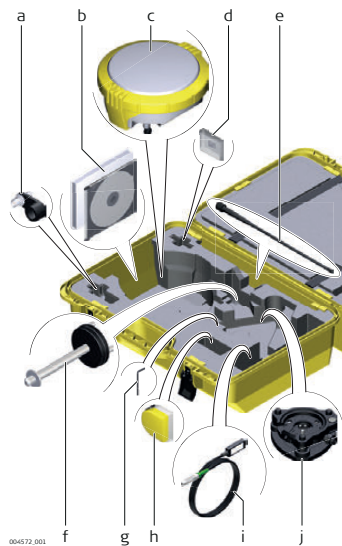

- a) ZAR200 antenna arm
- b) Quick Guide and CDs
- c) Zenith25 instrument
- d) microSD card in holder
- e) UHF radio antenna
- f) ZCA100 carrier
- g) Adjusting tool for tribrach
- h) Measuring tape
- i) Serial-to-USB converter cable
- j) ZTR100 tribrach

Container for Zenith25 instrument and accessories part 2 of 2

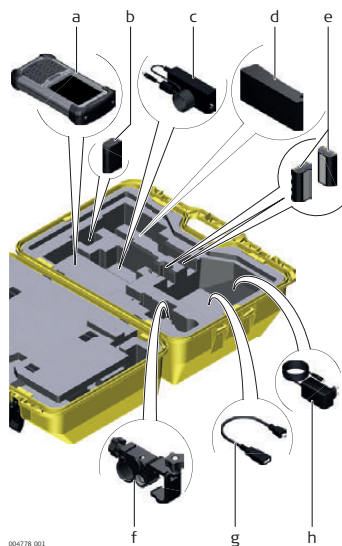

- a) Getac PS236 handheld
- b) Battery for handheld
- c) AC adapter for handheld
- d) ZCH201 battery charger
- e) ZBA200 batteries for instrument
- f) ZHR200 pole holder
- g) USB host cable for handheld
- h) AC adapter for battery charger

2.3 System Concept

2.3.1 Software Concept

Software upload

The software can be uploaded using GeoMax Assistant.

-  Ensure that a microSD card is inserted into the instrument before starting the upload. Refer to "4.4 Inserting a microSD card".

2.3.2 Power Concept

General

Use the GeoMax batteries, chargers and accessories or accessories recommended by GeoMax to ensure the correct functionality of the instrument.

Power options

Power for the instrument can be supplied either internally or externally.

Internal power supply: One ZBA200 battery fitting into the instrument.
External power supply: 10.5 V to 28 V DC power supply via ZDC225 cable.

2.3.3 Data Storage Concept

Description

GNSS raw data can be recorded on the microSD card.

Memory device

The instrument has a microSD card slot fitted as standard. A microSD card can be inserted and removed.

2.4 Instrument Components

Zenith25 components



- a) TNC-connector for external UHF antenna, only for models with UHF radio
- b) Battery compartment with microSD and SIM card slot
- c) Keyboard with LEDs, ON/OFF button and Function button
- d) Serial, USB and power port
- e) Mechanical Reference Plane (MRP) is where the instrument heights are measured to

2.5 Pin Assignments

Pin assignments for serial, USB and power port

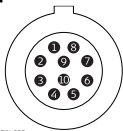

Pin	Signal Name	Function
1	USB_D+	USB data line
2	USB_D-	USB data line
3	GND	Signal ground
4	RxD	RS232, receive data
5	TxD	RS232, transmit data
6	ID	Identification pin
7	GPIO	RS232, general-purpose signal
8	PWR	Power input, 10.5 V-28 V
9	NC	Not used
10	NC	Not used

Plug type

10 pin LEMO EEG. 1B. 310. CLNP

2.6

The Mechanical Reference Plane, MRP

Description

The **Mechanical Reference Plane**:

- is where the instrument heights are measured to.
- is where the phase centre variations refer to.
- varies for different instruments.

MRP for instrument

The MRP for the instrument is shown in the diagram.



- a) The mechanical reference plane is the underside of the thread.
-

3 User Interface

3.1 Keyboard

Using the keyboard

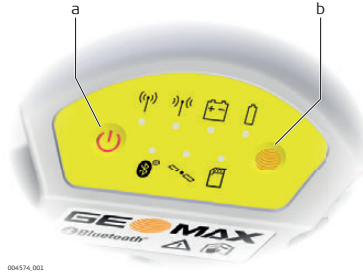



a) ON/OFF button
b) Function button

ON/OFF button



Button		Function
ON/OFF		<p>If Zenith25 is off: Turns on Zenith25 when held for 2 s. While the Zenith25 is booting the two Power LEDs flash.</p> <p>If Zenith25 is already on: Turns off Zenith25 when held for 2 s.</p>

Function button

 All functions described assume the Zenith25 is already on.

Button		Function
Function		<p>Press and hold button for <1 s.</p> <p>Switches the Zenith25 between rover or base mode.</p> <p>Press and hold button for 3 s.</p> <p>Updates the base position coordinates when Zenith25 is in base mode. The RTK base LED flashes for 2 s. When no position is available, the LED flashes red.</p> <p>Press and hold button for 5 s.</p> <p>Connects to the configured RTK base station or NTRIP server when the Zenith25 is in rover mode. The RTK rover LED flashes for 2 s. No action if a rover mode is not configured.</p>

Button combinations

Button		Function
ON/OFF		Press and hold buttons for 1 s.
Function		<p>The current almanacs stored on the GNSS instrument are deleted and new almanacs are downloaded. The Position LED flashes red three times.</p> <p>Press and hold buttons for 5 s.</p> <p>The Memory LED flashes red quickly three times. The microSD card of the GNSS instrument is formatted. The Memory LED continues to flash red as the SD card is formatted.</p> <p>Press and hold buttons for 10 s.</p> <p>The System RAM on the GNSS instrument is formatted. Settings of all installed software will be deleted. The Storage, RTK Base and RTK Rover LEDs flash red. The Position LED flashes yellow quickly three times. After the formatting the System RAM, the GNSS instrument is turned off.</p> <p>Press and hold buttons for 15 s.</p> <p>The registry of the GNSS instrument is deleted. Windows CE and Bluetooth communication settings will be reset to factory defaults. The Storage, RTK Base and RTK Rover LEDs flash red. The Position LED flashes yellow quickly three times. After deleting the registry, the GNSS instrument is turned off.</p>

LED indicators

Description

The Zenith25 has Light Emitting Diode indicators. They indicate the basic instrument status.

Diagram

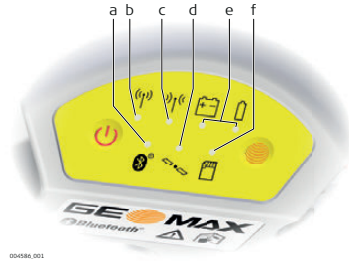

- a) Bluetooth LED
- b) RTK Base LED
- c) RTK Rover LED
- d) Position LED
- e) Power LEDs
- f) Storage LED

Description of the LEDs

IF the	is	THEN
Bluetooth LED	green	Bluetooth is in data mode and ready for connecting.
	blue	Bluetooth has connected.
RTK Base LED	green	Zenith25 is in RTK base mode. No RTK data is being passed to the interface of the communication device.
	flashing green	Zenith25 is in RTK base mode. Data is being passed to the interface of the communication device.
RTK Rover LED	green	Zenith25 is in rover mode. No RTK data is being received at the interface of the communication device.
	flashing green	Zenith25 is in rover mode. RTK data is being received at the interface of the communication device.
Position LED	off	no satellites are tracked.
	flashing yellow	less than four satellites are tracked, a position is not yet available.
	yellow	a navigated position is available.
	flashing green	a code-only position is available.
	green	a fixed RTK position is available.
Power LED	off	battery is not connected, flat or Zenith25 is switched off.
	green	power is 20% - 100%.
	red	power is 5% - 20%. The remaining time for which enough power is available depends on the type of survey, the temperature and the age of the battery.
	fast flashing red	power is low (<5%).
Storage LED	off	no microSD card is inserted.
	green	microSD card is inserted but no raw data is being logged.
	flashing green	raw data is being logged.
	flashing red	raw data is being logged but only 5% memory left.
	red	microSD card is full, no raw data is being logged or no microSD card is inserted but Zenith25 is configured to log raw data.

4 Operation

4.1 Guidelines for Correct Results with GNSS Surveys

Undisturbed satellite signal reception

Successful GNSS surveys require undisturbed satellite signal reception, especially at the instrument which serves as a base. Set up the instrument in locations which are free of obstructions such as trees, buildings or mountains.

Steady instrument for static surveys

For static surveys, the instrument must be kept perfectly steady throughout the whole occupation of a point. Place the instrument on a tripod or pillar.

Centred and levelled instrument

Centre and level the instrument precisely over the marker.

4.2 Equipment Setup

4.2.1 Setting up as a Real-Time Base

Use

The following equipment setup is used for real-time base stations. Raw observation data can also be collected for post-processing.

Equipment setup - Zenith25

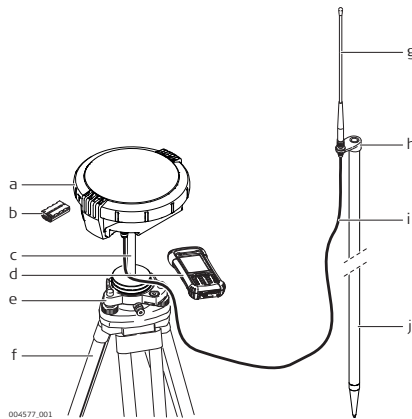

- a) Zenith25 instrument
- b) ZBA200 battery
- c) ZCA100 carrier
- d) Getac PS236 handheld
- e) Tribach
- f) Tripod
- g) UHF antenna
- h) ZAR200 antenna arm
- i) ZDC202 antenna cable
- j) ZPC200 pole

Equipment setup step-by-step

Step	Description
1.	Set up the tripod.
2.	Mount the tribach on the tripod.
3.	Ensure that the tribach is over the marker.
4.	Mount and level the carrier on the tribach.
5.	Insert the battery into the instrument.
6.	Connect the UHF antenna to the instrument using the ZAR200 arm and the ZDC202 cable.
7.	Press the ON/OFF button on the instrument for 2 s to switch on the instrument.
8.	Screw the instrument onto the carrier.
9.	Check that the tribach and carrier are still level.
10.	Connect the handheld to the instrument through Bluetooth.
11.	Measure the instrument height using the measuring tape. Refer to "2.6 The Mechanical Reference Plane, MRP" for information on the instrument height.

4.2.2

Setting up as a Post-Processing Base

Use

The following equipment setup is used for static operations over markers.

Equipment setup - Zenith25

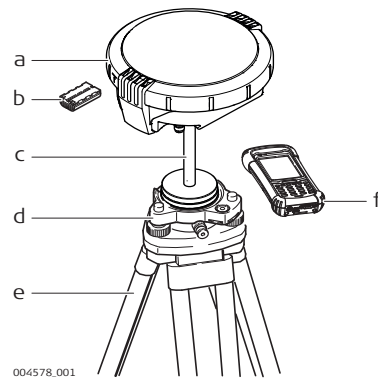

- a) Zenith25 instrument
- b) ZBA200 battery
- c) ZCA100 carrier
- d) Tribrach
- e) Tripod
- f) Getac PS236 handheld

Equipment setup step-by-step

Step	Description
1.	Set up the tripod.
2.	Mount the tribrach on the tripod.
3.	Ensure that the tribrach is over the marker.
4.	Mount and level the carrier on the tribrach.
5.	Insert the battery into the instrument.
6.	Press the ON/OFF button on the instrument for 2 s to switch on the instrument.
7.	Screw the instrument onto the carrier.
8.	Check that the tribrach and carrier are still level.
9.	Connect the handheld to the instrument through Bluetooth.
10.	Measure the instrument height using the measuring tape. Refer to "2.6 The Mechanical Reference Plane, MRP" for information on the instrument height.

4.2.3

Setting Up as a Real-Time Rover

Use

The following equipment setup is used for real-time rover.

Equipment setup - Zenith25

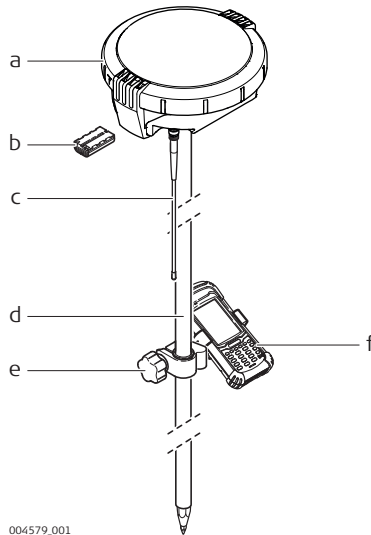

004579_001

- a) Zenith25 instrument
- b) ZBA200 battery
- c) UHF antenna
- d) ZPC200 pole
- e) ZHR200 holder
- f) Getac PS236 handheld

Equipment setup step-by-step

Step	Description
1.	Attach the ZHR200 holder to the ZPC200 pole. Refer to "4.2.4 Fixing the handheld to a holder and pole".
2.	Clip the handheld into the holder and lock it by tightening the screw on the holder.
3.	Turn on the handheld.
4.	Insert the battery into the instrument.
5.	Connect the UHF antenna to the instrument (only required when using the internal radio).
6.	Press ON/OFF button on the instrument for 2 s to switch on the instrument.
7.	Screw the instrument to the top of the pole.
8.	Connect the handheld to the instrument through Bluetooth.  When receiving RTK corrections with the Getac 3G, then the handheld must be connected to the instrument by serial cable.

4.2.4

Fixing the handheld to a holder and pole

Components of the ZHR200 holder

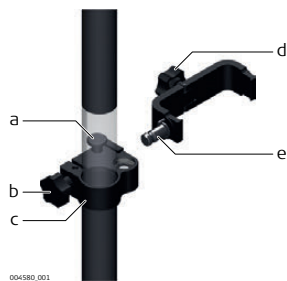

004580_001

Clamp

- a) Locking pin
- b) Tightening screw
- c) Pole clamp

Holder

- d) Tightening screw
- e) Pin

Fixing the handheld to the holder step-by-step

Step	Description
1.	Insert the pole into the clamp hole.
2.	Tighten the clamp with the tightening screw.
3.	To attach the holder to the clamp insert the pin into the catch of the clamp while pushing down the locking pin.
4.	Place the handheld in the holder.
5.	Tighten the screw of the holder to fix the handheld to the holder.

4.2.5

Connecting to a Personal Computer

Description

The instrument is connected to a Personal Computer via serial cable. After establishing a connection, the GeoMax Assistant software can be used to set up and configure the instrument, export data from the microSD card, enter licence keys and upload firmware.

Install software

Step	Description
1.	Start the PC.
2.	Download the GeoMax Assistant installation software and the Serial-to-USB cable driver from the GeoMax website.
3.	Install GeoMax Assistant and the cable driver.

Connect instrument to PC

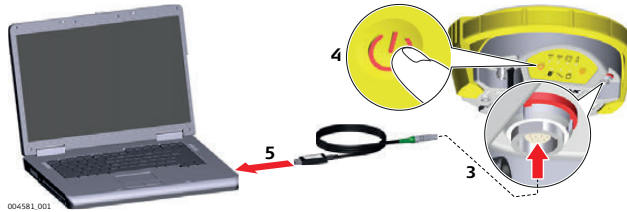

Step	Description
1.	Start the PC.
2.	Start GeoMax Assistant by double-clicking the shortcut from the desktop of your PC.
3.	Plug the included cable into the port of the instrument.
4.	Turn on the instrument.
5.	Plug the cable into the USB port of the PC. If Windows Hardware Wizard starts up, check CLOSE .

4.3

Batteries

4.3.1

Operating Principles

Charging / first-time use

- The battery must be charged prior to using it for the first time because it is delivered with an energy content as low as possible.
- The permissible temperature range for charging is between 0°C to +40°C/+32°F to +104°F. For optimal charging we recommend charging the batteries at a low ambient temperature of +10°C to +20°C/+50°F to +68°F if possible.
- It is normal for the battery to become warm during charging. Using the chargers recommended by GeoMax, it is not possible to charge the battery if the temperature is too high.
- For new batteries or batteries that have been stored for a long time (> three months), it is effectual to make only one charge/discharge cycle.
- For Li-Ion batteries, a single discharging and charging cycle is sufficient. We recommend carrying out the process when the battery capacity indicated on the charger or on a GeoMax product deviates significantly from the actual battery capacity available.

Operation / Discharging

- The batteries can be operated from -20°C to +55°C/-4°F to +131°F.
- Low operating temperatures reduce the capacity that can be drawn; high operating temperatures reduce the service life of the battery.

Change battery step-by-step

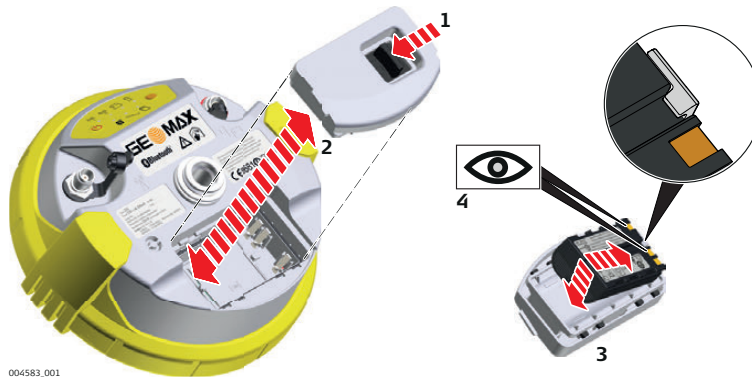

004583_001

Step	Description
	The battery is inserted in the bottom part of the instrument.
1.	Push the slide fastener of the battery compartment in the direction of the arrow with the open-lock symbol.
2.	Remove the cover from the battery compartment.
3.	With the battery contacts facing upwards, slide the battery into the cover of the battery compartment.
4.	Push the battery downwards so that it locks into position.
5.	Insert the cover of the battery compartment into the compartment and push the slide fastener in the direction of the arrow with the close-lock symbol.
6.	To remove a battery, push the slide fastener of the battery compartment in the direction of the arrow with the open-lock symbol and remove the cover.
7.	Push the battery slightly upwards and at the same time pull out the bottom part of the battery. This releases the battery from its fixed position.
8.	Remove the battery.

4.4

Inserting a microSD card



- Keep the card dry.
- Use it only within the specified temperature range.
- Do not bend the card.
- Protect the card from direct impacts.



Failure to follow these instructions could result in data loss and/or permanent damage to the card.

Insert a microSD card step-by-step

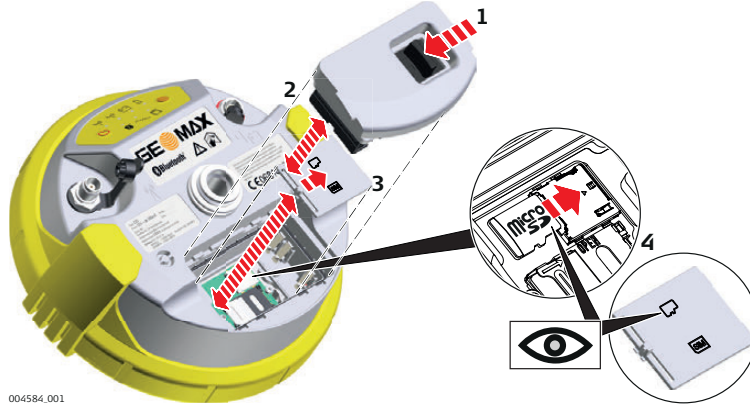

004584_001

Step	Description
	Removing the microSD card while the instrument is turned on can cause loss of data. Only remove the microSD card or unplug connecting cables when the instrument is switched off.
	The microSD card is inserted into a slot inside the battery compartment of the instrument.
1.	Push the slide fastener of the battery compartment in the direction of the arrow with the open-lock symbol.
2.	Remove the cover from the battery compartment.
3.	Press the latch of the SIM/microSD card cover and remove the cover.
4.	Slide the microSD card with the logo facing upwards firmly into the slot until it clicks into position.

Inserting a SIM card step-by-step

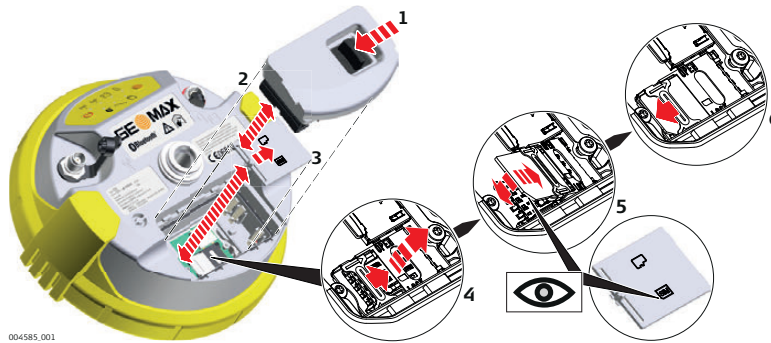

004585_001

Step	Description
	Inserting/removing the SIM card while the Zenith25 is turned on can result in permanent damage to the card. Only insert/remove the SIM card when the Zenith25 is switched off.
	The SIM card is inserted into a slot inside the battery compartment.
1.	Push the slide fastener of the battery compartment in the direction of the arrow with the open-lock symbol.
2.	Remove the cover from battery compartment.
3.	Press the latch of the SIM/microSD card cover and remove the cover.
4.	Push the SIM card holder in the direction of the OPEN arrow and flip it up.
5.	Place the SIM card into the SIM card holder, the chip facing the connectors inside the slot - as shown on the SIM/microSD card cover. Press the SIM card holder down.
6.	Push the SIM card holder in the direction of the LOCK arrow to close.

5 Care and Transport

5.1 Transport

Transport in the field	When transporting the equipment in the field, always make sure that you <ul style="list-style-type: none">• either carry the product in its original transport container,• or carry the tripod with its legs splayed across your shoulder, keeping the attached product upright.
Transport in a road vehicle	Never carry the product loose in a road vehicle, as it can be affected by shock and vibration. Always carry the product in its transport container and secure it.
Shipping	When transporting the product by rail, air or sea, always use the complete original GeoMax packaging, transport container and cardboard box, or its equivalent, to protect against shock and vibration.
Shipping, transport of batteries	When transporting or shipping batteries, the person in charge of the product must ensure that the applicable national and international rules and regulations are observed. Before transportation or shipping, contact your local passenger or freight transport company.

5.2 Storage

Product	Respect the temperature limits when storing the equipment, particularly in summer if the equipment is inside a vehicle. Refer to "6 Technical Data" for information about temperature limits.
Li-Ion batteries	<ul style="list-style-type: none">• Refer to "6 Technical Data" for information about storage temperature range.• Remove batteries from the product and the charger before storing.• After storage recharge batteries before using.• Protect batteries from damp and wetness. Wet or damp batteries must be dried before storing or use.• A storage temperature range of 0°C to +30°C / +32°F to +86°F in a dry environment is recommended to minimize self-discharging of the battery.• At the recommended storage temperature range, batteries containing a 40% to 50% charge can be stored for up to one year. After this storage period the batteries must be recharged.

5.3 Cleaning and Drying

Product and accessories	<ul style="list-style-type: none">• Use only a clean, soft, lint-free cloth for cleaning. If necessary, moisten the cloth with water or pure alcohol. Do not use other liquids; these may attack the polymer components.
Damp products	Dry the product, the transport container, the foam inserts and the accessories at a temperature not greater than 40°C/104°F and clean them. Remove the battery cover and dry the battery compartment. Do not repack until everything is dry. Always close the transport container when using in the field.
Cables and plugs	Keep plugs clean and dry. Blow away any dirt lodged in the plugs of the connecting cables.
Connectors with dust caps	Wet connectors must be dry before attaching the dust cap.

6 Technical Data

6.1 Technical Data

6.1.1 Tracking Characteristics

Tracking	GNSS receiver:	NovAtel OEM615 dual frequency with 120 channels
	Signals tracked:	GPS: L1, L2, L2C GLONASS: L1, L2 Galileo: *
	Initialization:	Initialization time < 10 s Initialization reliability > 99.9%

* The optional Galileo tracking will be made available once there are sufficient of these satellites.

6.1.2 Accuracy

Differential code The baseline precision of a differential code solution for static and kinematic surveys is 25 cm.

Static	Horizontal:	5 mm + 0.5 ppm
	Vertical:	10 mm + 0.5 ppm

Kinematic	Horizontal:	10 mm + 1 ppm
	Vertical:	20 mm + 1 ppm

Static with long observations	Horizontal:	3 mm + 0.1 ppm
	Vertical:	3.5 mm + 0.4 ppm



Accuracy is dependent upon various factors including the number of satellites tracked, constellation geometry, observation time, ephemeris accuracy, ionospheric disturbance, multipath and resolved ambiguities.

The accuracies, given as root mean square, are based on measurements processed using GeoMax Geo Office and on real-time measurements.

6.1.3 GNSS antenna specifications

GNSS antenna specifications	Phase centre error:	± 2 mm
	LNA gain:	Typically 33 dBi
	Noise figure:	Typically ≤ 3dBi

6.1.4 Internal devices

Internal devices	GSM/GPRS module:	Cinterion BGS2-W Quad-Band EGSM 850/900/1800/1900 MHz
	UHF radio module:	Microhard nL400, transceiver Transmission power 0.5 and 1.0 W Frequency range 406 to 480 MHz
	Bluetooth:	Class 2

6.1.5 Technical Data

Dimensions	Height:	95 mm (3.7")
	Diameter:	198 mm (7.8")

Weight	1.20 kg/2.65 lbs including ZBA200 battery
--------	---

Recording	GNSS raw data can be recorded on a microSD card. 1 GB capacity is typically sufficient for about 7000 h dual frequency logging at a 15 s rate (average constellation).
-----------	---

Power	ZBA200 internal battery:	Li-Ion 7.4 V / 2.2 Ah
	External power input:	10.5 V to 28 V DC with ZDC225 cable
	Power consumption:	Typically 2.0 W without radio

Internal battery ZBA200	Battery:	Li-Ion
	Voltage:	7.4 V
	Capacity:	2.2 Ah

Operating times	Equipment type	Operating time
	Static:	
Rover (radio; Microhard nL400, receive):		5 h
Rover (Digital cellular phone; Cinterion BGS2-W):		5 h

 Operating times may vary depending on the temperature and battery age.

6.1.6 Environmental specifications

Environmental specifications	Temperatures (°C):		
	Instrument:	-40 to +65 (operation)	-40 to +80 (storage)
	ZBA200 battery:	-20 to +55 (operation)	-40 to +70 (storage)
	Protection:		
	IP68 (IEC 60529)		
	Vibration:		
	Vibration test according to ISO 9022-36-05		
	Shock:		
	Withstands a 2 m (6.6 ft) pole topple over onto hard surface.		
	Humidity:		
100% condensing			
The effects of condensation are to be effectively counteracted by periodically drying out the instrument.			

Index

A	
Antenna	
Technical Data	9
B	
Batteries	
Operation, Discharging	18
Battery	
Change in instrument	19
For internal power supply	11
Bluetooth	
LED on instrument	14
Buttons	
Combined pressing	13
Function	13
ON/OFF	13
D	
Data recording	
GNSS raw data	23
RINEX	23
Definition of Use	4
Description of the system	10
Dimensions	23
E	
Environmental specifications	
Instrument	24
External power supply	11
F	
FCC Statement	8
G	
GeoMax Geo Office	10
I	
Indicators, LED	
Instrument	14
Insert	
SIM card	21
Instrument	
Insert microSD card	20
Remove microSD card	20
Status	14
Instrument components	11
Internal power supply	11
K	
Keyboard	
Instrument	13
L	
Labelling	
Instrument	8
ZBA200	8
LED, Description	
Instrument	14
Light Emitting Diode	
Instrument	14
Li-Ion battery	
Storage	22
M	
Mechanical Reference Plane	12
Memory device	
Available	11
microSD card	
Insert	20
Remove	20
MRP	12
O	
Operating times	
Instrument	24
Output power	
Instrument	9
P	
Pin Assignment	11
Position	
LED on Instrument	14
Power	
Instrument	24
Power LED	
Instrument	14
Power supply	11
R	
Raw data logging	
GNSS	23
RINEX	23
Recording	23
Remove	
SIM card	21
Responsibilities	4
RTK Base	
LED on instrument	14
RTK Rover	
LED on instrument	14
S	
Safety Directions	4
SIM card	
Insert	21
Remove	21
Software	
Upload	11
Specifications, environmental	
Instrument	24
Status	
Instrument	14
Storage	
LED on instrument	14
T	
Temperature range	
Product, drying	22
Time, operating	24
U	
Upload software	11
User Interface	13
User Manual	
Validity of	2

W

Weight

Instrument 23

GeoMax Zenith25



797033(CD)-1.0.0en

Original text

© 2013 GeoMax AG, Widnau, Switzerland

GeoMax AG
www.geomax-positioning.com