

---

***Mini-indicator***

***User Manual***













---



---

---

# Table of Contents

Safety Precaution .....	2
Chapter 1 Keypad Instruction .....	3
Chapter 2 Specifications.....	4
Chapter 3 Front and Rear Panels.....	5
3-1 Front Panel.....	5
3-2 Rear Panel .....	6
Chapter 4 Installation .....	7
4-1 Load Cell.....	7
4-2 Dimensions .....	8
4-3 Battery Assemblage.....	9
Chapter 5 External Function Parameter Setting.....	10
5-1   F  External Function Setting.....	11
5-2   RS-232 Setting.....	13
Chapter 6 Internal Calibration .....	18
6-1   S P Specification Calibration .....	19
6-2   A L Weight Calibration .....	22
6-3   F  Internal Function Setting.....	24
6-4 Error Messages.....	26
Chapter 7 Special Function .....	27
7-1 Animal Scale Setting .....	27
7-2 Dual Range Resolution Switch Function .....	28
7-3 Pre-Tare Function .....	29
7-4 Resolution Switch Function .....	29
7-5 Maintain Beeper Value Setting .....	30
Chapter 8 Interface .....	31
8-1 OP-01 RS-232 / RS-485 Serial Output with RTC.....	31
Chapter 9 Maintenance .....	33
9-1 Restore Default Setting for All Parameters(General Certification).....	33
9-2 Restore Default Setting for All Parameters (OIML Certification) .....	33
9-3 Restore Default Setting for General Function Parameters.....	33
9-4 Self-test Mode .....	33
9-4-1 Program Version Number.....	35
9-4-2 7-segment Display Testing.....	35
9-4-3 Keypad & Calibration Switch Testing.....	35
9-4-4 A/D Conversion Value.....	35
9-4-5 EEPROM Testing .....	35
9-4-6 RTC Time & Date Testing.....	35
9-4-7 RS-232 Serial Output Interface Testing ( OP - 01 ).....	35
Appendix 7-Segment Display Characters .....	36







---

---





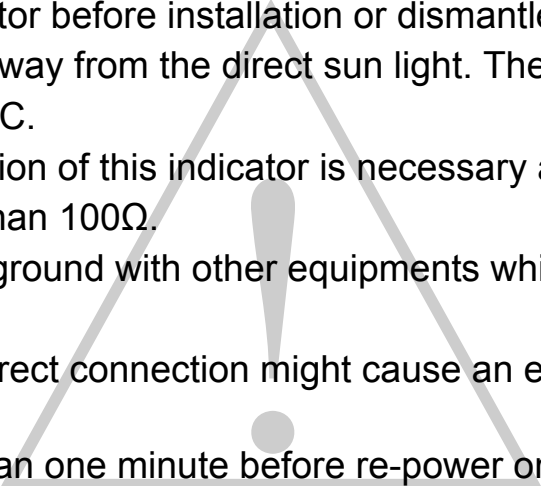

## ***Before using the product***

Thanks for your purchase of this indicator. In order to operate it smoothly, extend its durability and reduce the chance of breakdown, please read this user manual carefully.

## ***Safety Precaution***

-  Switch off the indicator before installation or dismantlement.
  -  Keep the indicator away from the direct sun light. The operation temperature is between 0 ~ +40°C.
  -  The ground connection of this indicator is necessary and this ground impedance is less than 100Ω.
  -  Do not connect the ground with other equipments which need huge power consumption.
  -  Non-ground or incorrect connection might cause an electric shock or a product breakdown.
  -  Please wait more than one minute before re-power on.
- 

# Chapter 1 Keypad Instruction

Function	Operation	Description
General Function Setting	Press and hold  , then press 	Refer to <Chapter 5> External Function Parameter Setting for details
Weighing Parameter Setting	Adjust calibration switch to ON	Setting for decimal point, capacity, division, zero tracking, and unstable detection, etc. Refer to 6-1 Specification Setting for details.
Calibration	Adjust calibration switch to ON	Refer to 6-2 Weight Calibration for details.
Self-test Mode	During the countdown of power on, press and hold 	Refer to 9-4 Self-test Mode for details.
Restore Default Setting for All Parameters	Adjust calibration switch to ON, and then press and hold  and 	Refer to 9-1 for details.
Restore Default Setting for General Function Parameters	During the countdown of power on, press and hold  and 	Refer to 9-3 for details.

 During the operation, use the following keys to complete all works.



⇒ Increase the flash value by one



⇒ Move the cursor rightward



⇒ Decrease the flash value by one



⇒ Save setting



⇒ Move the cursor leftward



⇒ Abort setting / Exit

---

---

# Chapter 2 Specifications

## Analog Specification

- ◆ Load Cell Current : DC 5 V  $\pm$ 5% 60 mA (Up to Four 350  $\Omega$  Load Cells)
- ◆ Max. Load Cell Input Voltage : 16 mV
- ◆ Input Sensitivity : 0.15  $\mu$ V/d or more
- ◆ Conversion Rate : Approximately 120 times/s (max.)
- ◆ Resolution : 20 bits

## Digital Specification

- ◆ Display : LCD, 6 digits, 25.4 x 10 mm (W x H), LED backlight
- ◆ Display Frequency : 50 times/s (max)
- ◆ Display Range : - 999999 ~ 999999
- ◆ Min. Division : 1, 2, 5, 10, 20, 50
- ◆ Decimal Point : 0, 0.0, 0.00, 0.000, 0.0000
- ◆ Memory : Calibration parameters and function settings are all stored in EEPROM.

## Optional Interface Card

- ◆ OP-01 RS-232 / RS-485 (Includes RTC Function)

## Power Requirement

- ◆ Adaptor Spec : Input 120 / 230 V AC 50 ~ 60 Hz  
Output 9 V / 1000 mA
- ◆ Optional 2 types of batteries : 6 V NiMH rechargeable battery kit (5 pcs) (1800 mA/hr) or general batteries (5 pcs)
- ◆ Max. Power Consumption : 110 mA (with 4 Load Cells + backlight + RS-232 interface)  
NiMH battery  $\rightarrow$  15 hours  
General battery  $\rightarrow$  24 hours  
45 mA (with 1 Load Cell + no backlight + no RS-232 interface)  
NiMH battery  $\rightarrow$  36 hours  
General battery  $\rightarrow$  60 hours

☞ Please charge the Ni-MH battery at least 12~14 hours for first use.

## Others

- ◆ Operation Temperature : 0 ~ 40  $^{\circ}$ C
- ◆ Operation Humidity : < 85% R.H.
- ◆ Dimensions (W  $\times$  D  $\times$  H) (mm) : 193  $\times$  49.5  $\times$  94.4 (excluding protrusions)  
225  $\times$  60  $\times$  134.7 (including protrusions)
- ◆ Weight : 700 g

---



---

# Chapter 3 Front and Rear Panels

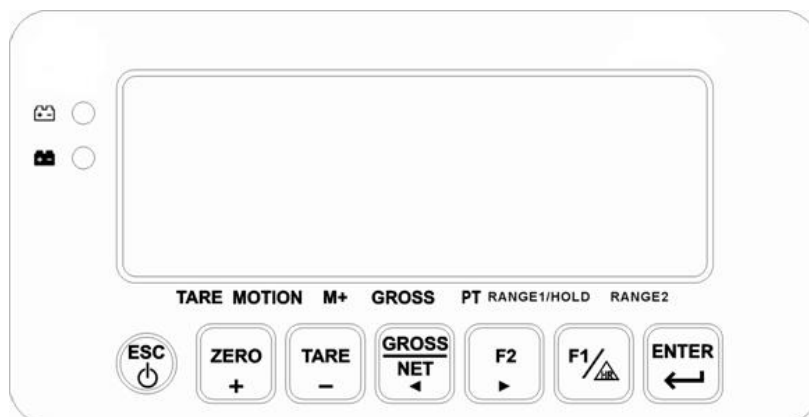
## 3-1 Front Panel



### Indication:







-  : Battery is charged (only available for rechargeable model)
-  : Battery is charging (only available for rechargeable model)
- TARE : Tare mode
- MOTION : Unstable weighing
- M+ : Accumulation mode
- GROSS : Gross weight
- PT : Pre-Tare
- RANGE1/HOLD : Dual-range resolution indication (1)
- RANGE2 : Dual-range resolution indication (2)

Description of RANGE1 and HOLD:

The light is default on. When using CFN-05 Animal Scale Mode or FNC-07 Maintain Beeper Value, it works as HOLD LED light. When opening dual-range resolution, it works as RANGE1 LED light.

CFN-05 Animal Scale Mode and FNC-07 Maintain Beeper Value can't be run at the same time.

### Keypad:

-  1) Power ON / OFF. Press and hold this key for 3 seconds to shut down.  
2) Abort or exit when setting.
-  1) Weight backs to zero.  
2) Increase the flash value by one when setting.
-  1) Eliminate the gross weight.  
2) Decrease the flash value by one when setting.
-  1) Switch Gross / Net weight shown on display.  
2) Move the cursor leftward when setting.
-  1) Keypad function (FNC-02 & FNC-03).  
2) Move the cursor rightward when setting.
-  Keypad function (FNC-02 & FNC-03).
-  Confirm key.

---

## 3-2 Rear Panel

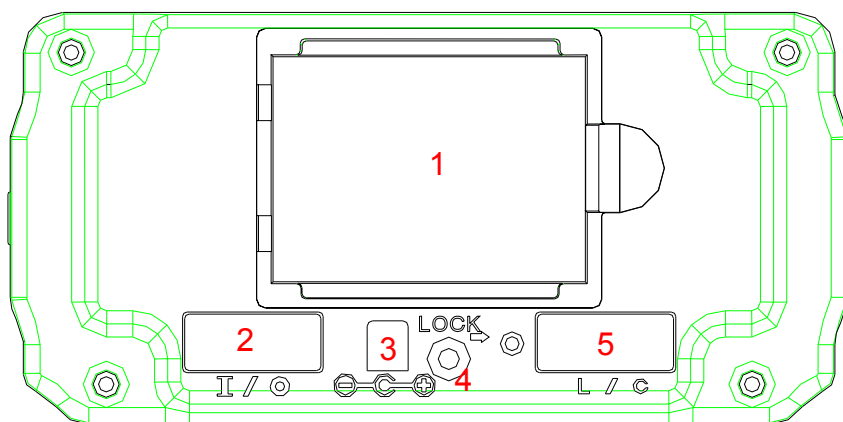

1. Battery Case
2. RS-232 / RS-485 Input / Output
3. DC 9 V Power Input
4. Calibration Switch
5. Load Cell Connect Socket



---

---

# Chapter 4 Installation

## 4-1 Load Cell

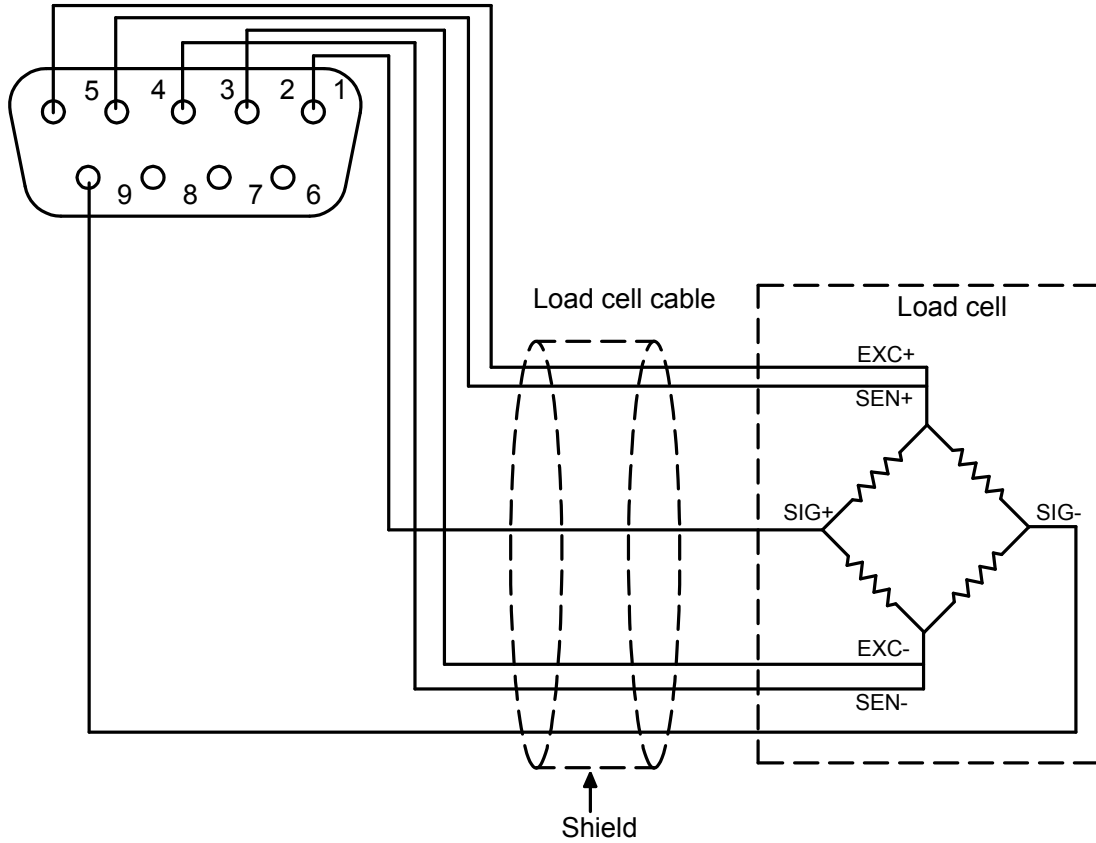

### 4-wired (5-wired) Load Cell

- Pin 1 connects with SIG+
- Pin 2, 3 short to connect with EXC-
- Pin 4, 5 short to connect with EXC+
- Pin 6, 7, 8 connect with shield
- Pin 9 connects with SIG-

### 6-wired (7-wired) Load Cell

- Pin 1 connects with SIG+
- Pin 2 connects with SEN-
- Pin 3 connects with EXC-
- Pin 4 connects with SEN+
- Pin 5 connects with EXC+
- Pin 6, 7, 8 connect with shield
- Pin 9 connects with SIG-

## 4-2 Dimensions

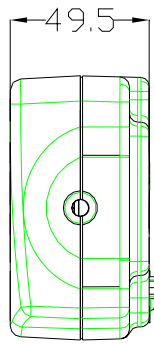
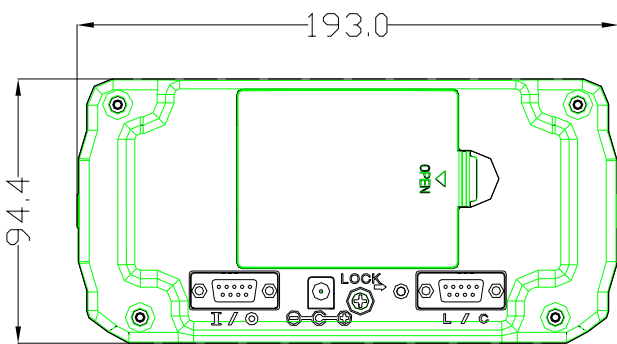
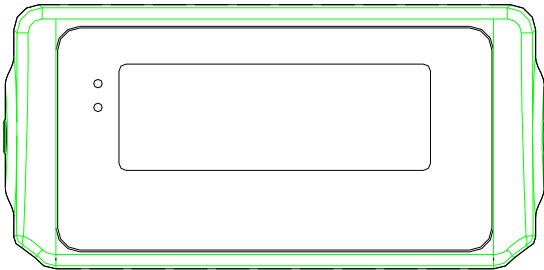
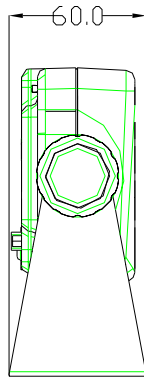
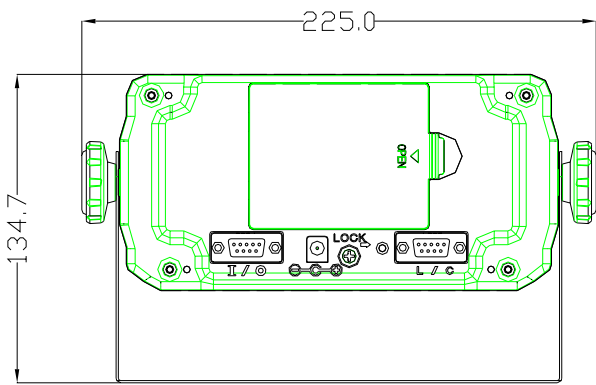
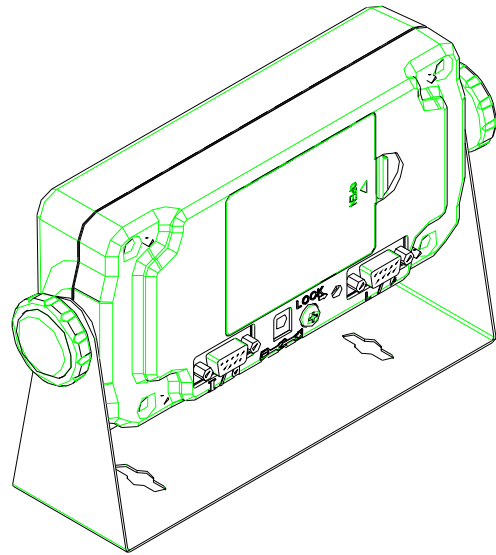
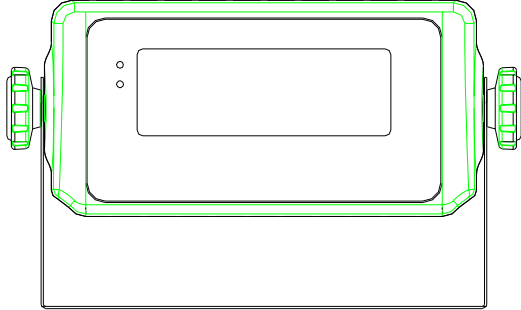

---

## 4-3 Battery Assemblage

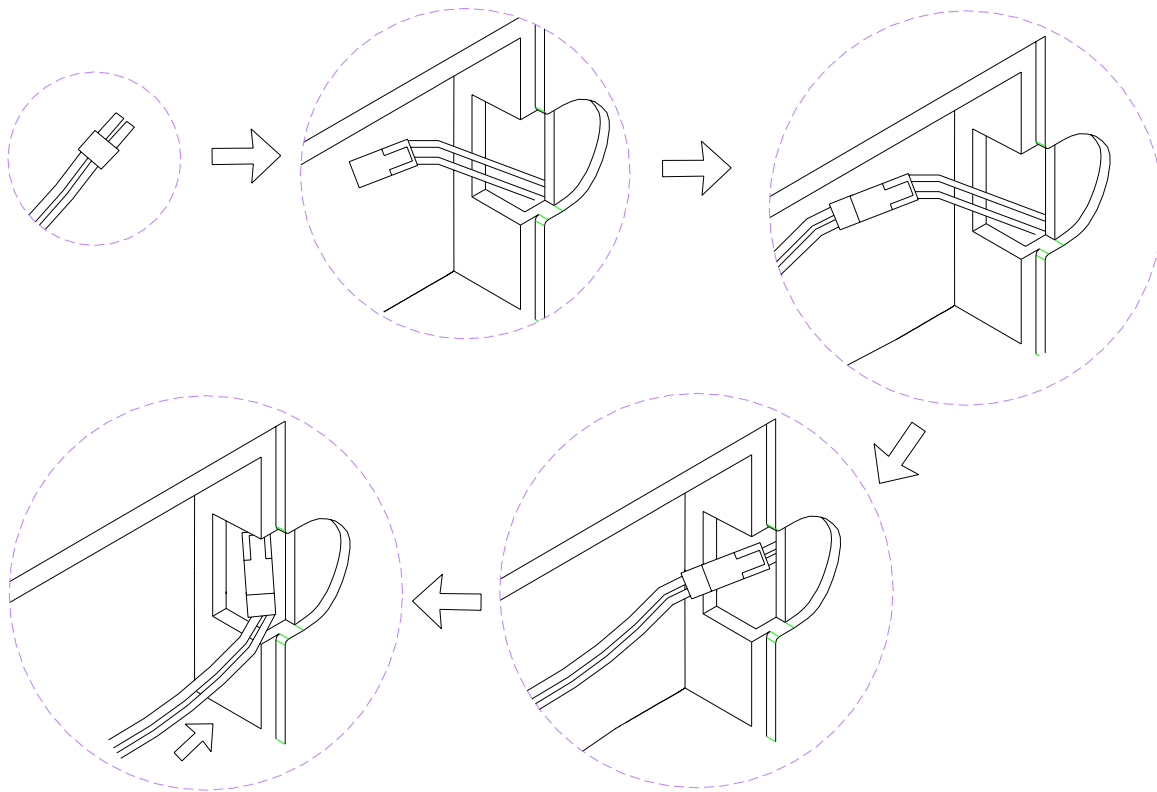

Stuff the surplus wires into the battery case.

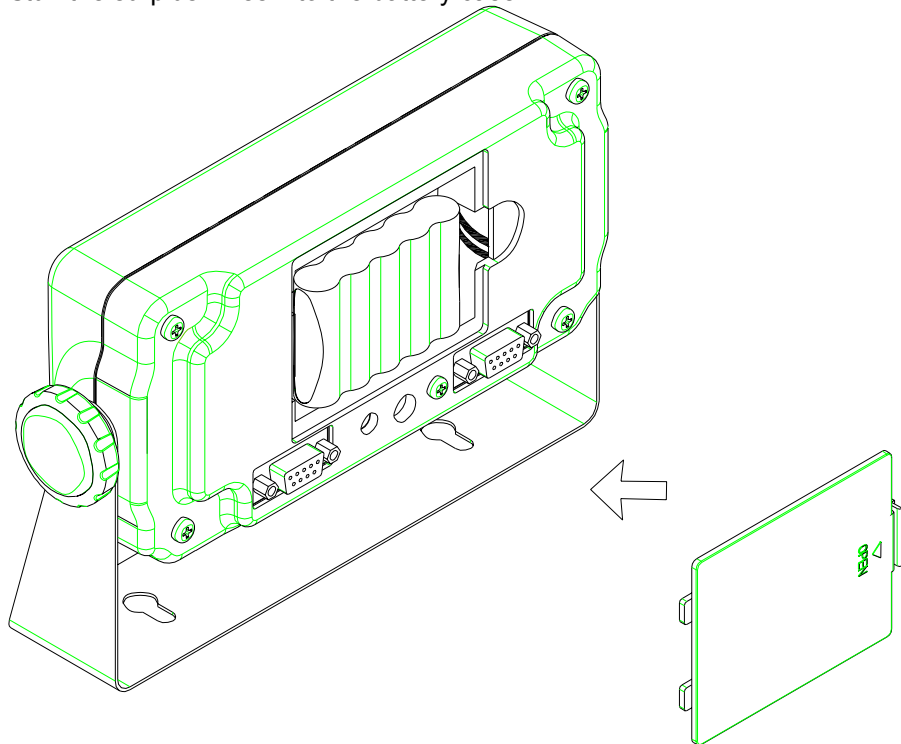

# Chapter 5 External Function Parameter Setting

Under general weighing condition, press   , and the screen will show:

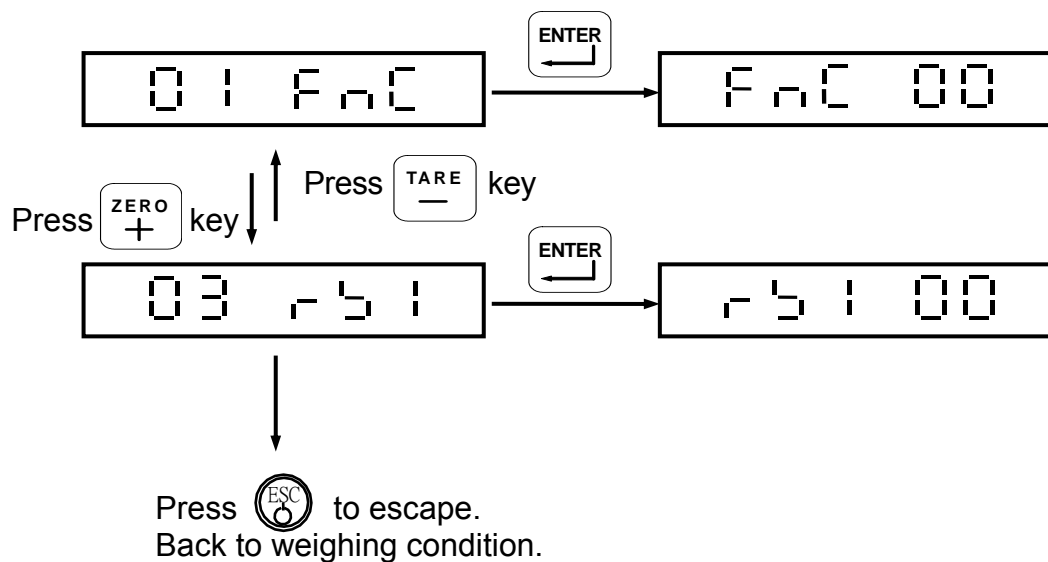

0 1 F n C ⇒ External function setting

0 3 r b i ⇒ RS-232 / RS-485 interface function

## 5-1 0 1 F n C External Function Setting

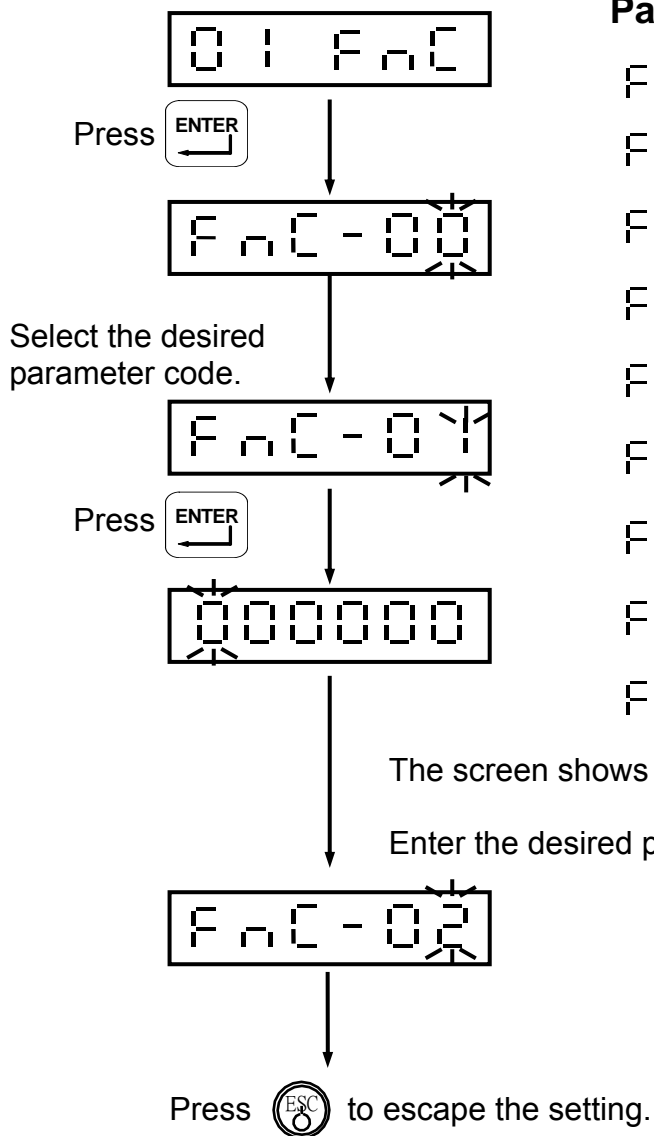





### Parameter Code

- F n C - 0 0 ⇒ Key Disable
- F n C - 0 1 ⇒ DSP Update (Display Update)
- F n C - 0 2 ⇒ F1 Setting
- F n C - 0 3 ⇒ F2 Setting
- F n C - 0 4 ⇒ ENTER + F2 Setting
- F n C - 0 5 ⇒ Backlight Function Setting
- F n C - 0 6 ⇒ Beeper Setting
- F n C - 0 7 ⇒ Maintain Beeper Value
- F n C - 0 8 ⇒ Auto-power Off

	⇒ Increase the flash value by one
	⇒ Decrease the flash value by one
	⇒ Move the cursor leftward
	⇒ Move the cursor rightward
	⇒ Save setting
	⇒ Abort setting or exit

## External Function Parameter Setting

Parameter Code	Function	Setting Value				Default Setting
		Parameter	Description			
FNC-00	Key disable	0000	0	ON	0000 is corresponding to:(from left to right)    	0*000
		↓ 1111	1	OFF		
FNC-01	DSP Update	0	No Limit			1
		1	20 times/s			
		2	10 times/s			
		3	5 times/s			
		4	1 times/s			
FNC-02	F1 Setting	0	Print (printing)			5
		1	Units (units switch)			
		2	M+ (accumulation and printing)			
		3	MC (memory clearing)			
		4	Weight / Times Accumulation / Weight Accumulation Display Switch			
		5	HR (high resolution switch)			
		6	Pre-Tare (Pre-Tare function)			
FNC-03	F2 Setting	0	Print (printing)			1
		1	Units (units switch)			
		2	M+ (accumulation and printing)			
		3	MC (memory clearing)			
		4	Weight / Times Accumulation / Weight Accumulation Display Switch			
		5	HR (high resolution switch)			
		6	Pre-Tare (Pre-Tare function)			
FNC-04	ENTER+F2 Setting	0	Print (printing)			0
		1	Units (units switch)			
		2	M+ (accumulation and printing)			
		3	MC (memory clearing)			
		4	Weight / Times Accumulation / Weight Accumulation Display Switch			
		5	HR (high resolution switch)			
		6	Pre-Tare (Pre-Tare function)			
FNC-05	Backlight Setting	0	Auto Backlight On (backlight on in operation only)			1
		1	Backlight On (backlight always on)			
		2	Backlight Off			
FNC-06	Beeper Setting	0	Beeper off			1
		1	Beeper on			
FNC-07	Maintain Beeper Value	0*	No function			0
		1	Mode 1			
		2	Mode 2			
FNC-08	Auto-power Off (Minutes)	0	No function			0
		1 ~ 60	It works when the weight is stable and non-key is pressed in weighing mode.			

The symbol "\*" is standard for OIML Certification in context.

## 5-2 03 r51 RS-232 Setting

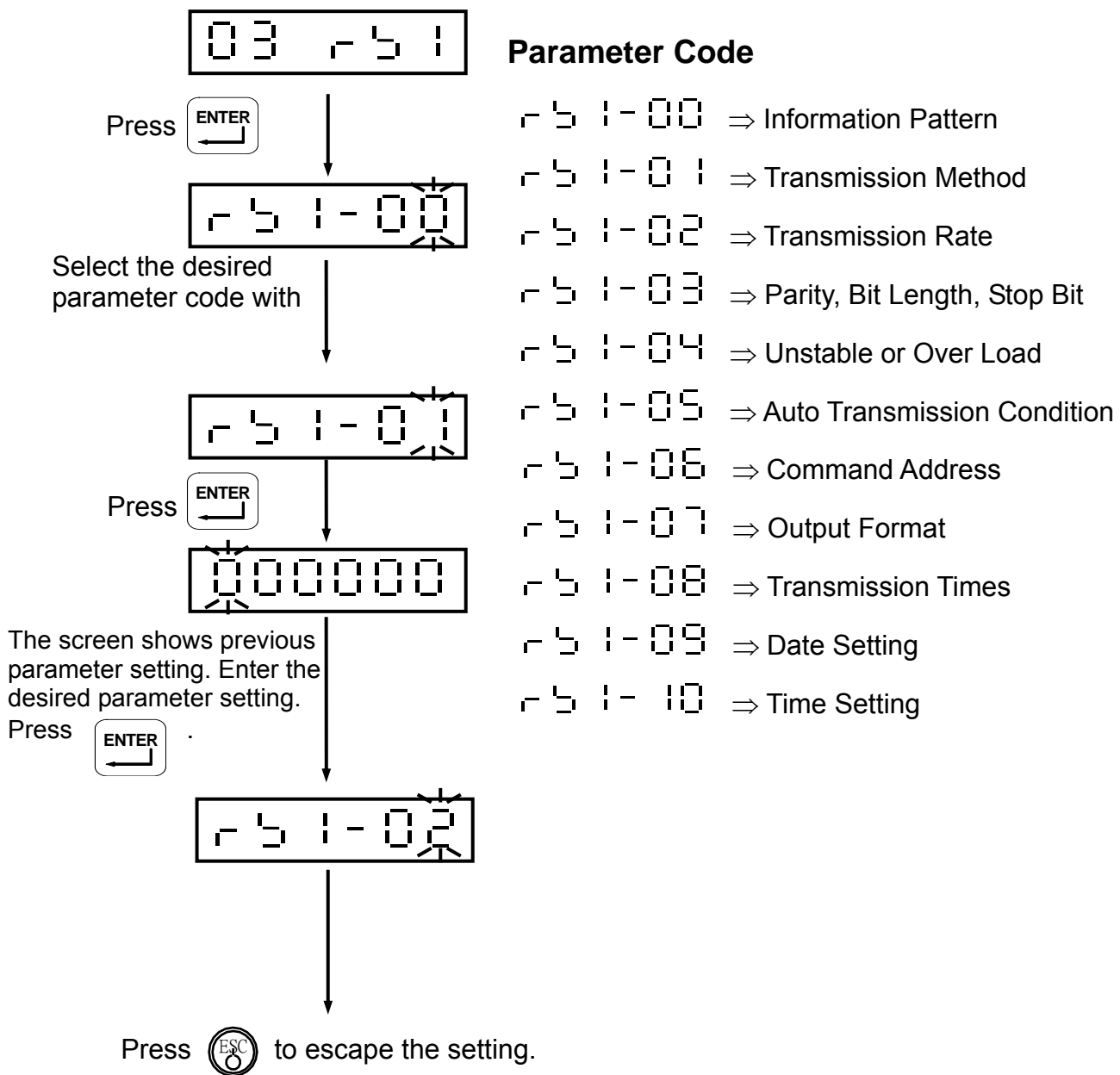



### Parameter Code

- r51-00 ⇒ Information Pattern
- r51-01 ⇒ Transmission Method
- r51-02 ⇒ Transmission Rate
- r51-03 ⇒ Parity, Bit Length, Stop Bit
- r51-04 ⇒ Unstable or Over Load
- r51-05 ⇒ Auto Transmission Condition
- r51-06 ⇒ Command Address
- r51-07 ⇒ Output Format
- r51-08 ⇒ Transmission Times
- r51-09 ⇒ Date Setting
- r51-10 ⇒ Time Setting

	⇒ Increase the flash value by one
	⇒ Decrease the flash value by one
	⇒ Move the cursor leftward
	⇒ Move the cursor rightward
	⇒ Save setting
	⇒ Abort setting or exit

## OP-01/ RS-232 / RS-485 Interface Function

Parameter Code	Function	Setting Value		Default Setting
		Parameter	Description	
RS1-00	Information Pattern	0	Display Correspondingly	0
		1	Gross Weight	
		2	Net Weight	
		3	Tare	
		4	Weight Accumulation Value	
		5	Times Accumulation Value	
		6	Output with Date & Time	
		7	PT Output with Date & Time	
RS1-01	Transmission Method	0	Continuous Transmission	0
		1	Auto Transmission	
		2	Press  or  for transmission	
		3	Command Mode (no address)	
		4	Command Mode (with address)	
RS1-02	Transmission Rate	0	1 200	3
		1	2 400	
		2	4 800	
		3	9 600	
RS1-03	Parity, Bit Length, Stop Bit	0	N,8,1 No Parity 8 Bits Length 1 Stop Bit	0
		1	O,7,1 Odd Parity, 7 Bits Length, 1 Stop Bit	
		2	E,7,1 Even Parity, 7 Bits Length, 1 Stop Bit	
RS1-04	Unstable or Over Load	0	Continuous Output	0
		1	Stop Output	
RS1-05	Auto Transmission Condition	0	Positive (over + 10d)	0
		1	Positive / Negative (over + 10d, under - 10d)	
RS1-06	Command Address	00 ↓ 99	Available only if RS1-01 setting is "4"	0
RS1-07	Output Format	0*	Standard Format	0
		1	UMC 600	

The symbol "\*" is standard for OIML Certification in context.



RS1-08	Transmission Times	0	No Limit	4
		1	1 times/s	
		2	2 times/s	
		3	5 times/s	
		4	10 times/s	
		5	20 times/s	
RS1-09	Date Setting			
RS1-10	Time Setting			

**Remark:**

- ☰ This is general certification option when the parameter is set for “0~5” in RS1-00 and the data is transmitted to printer.
- ☰ This is general certification option when the parameter is set for “6” in RS1-00 and the parameter is set for “6” in FNC-02 (or the parameter is set for “6” in FNC-03).
- ☰ This is general certification option when the parameter is set for “0” in RS1-04 and the parameter is set for “6” in RS1-00.

**☰ Transmission Format**

**RS1-00 ⇒ 0 ~ 3**

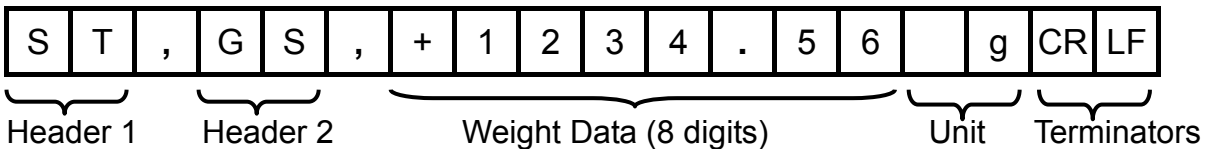

**Header 1**

ST: Stable Weight / US: Unstable Weight / OL: Weight Overload

**Header 2**

GS: Gross Weight / NT: Net Weight / TR: Tare

**Weight Data (8 digits)**

The first digit of weight data indicates “+ / -” value of weight. The other 7 digits, including decimal point, indicate the weight value. If the weight is over load (Header 1: OL), the screen only shows “+ / -” and decimal point.

**Unit**

(kg, t or “blank”)\* or kg, lb, t or “blank”

**Terminators**

CR and LF are data termination code.

**RS1-00 = 4**

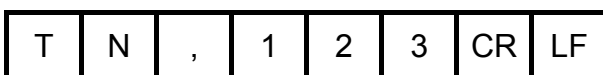

- ☰ The symbol “\*” is standard for OIML Certification in context.

---

---

RS1-00 = 5

T	W	,	+	1	2	3	4	.	5	6	k	g	CR	LF
---	---	---	---	---	---	---	---	---	---	---	---	---	----	----

RS1-00 = 6

D	A	T	E		:	2	0	X	X	/	X	X	/	X	X	CR	LF
T	I	M	E		:	X	X	:	X	X	:	X	X	CR	LF		
G	R	O	S	S	:	+	1	2	3	4	.	5	6	k	g	CR	LF
N	E	T			:	+	1	2	3	4	.	5	6	k	g	CR	LF
T	A	R	E		:	+	1	2	3	4	.	5	6	k	g	CR	LF
T	N				:	X	X	X	CR	LF							
T	W				:	+	1	2	3	4	.	5	6	k	g	CR	LF

RS1-00 = 7

D	A	T	E		:	2	0	X	X	/	X	X	/	X	X	CR	LF
T	I	M	E		:	X	X	:	X	X	:	X	X	CR	LF		
G	R	O	S	S	:	+	1	2	3	4	.	5	6	k	g	CR	LF
N	E	T			:	+	1	2	3	4	.	5	6	k	g	CR	LF
T	A	R	E		:	+	1	2	3	4	.	5	6	k	g	CR	LF
P	T				:	+	1	2	3	4	.	5	6	K	g	CR	LF
T	N				:	X	X	X	CR	LF							
T	W				:	+	1	2	3	4	.	5	6	k	g	CR	LF

## ☞ Command Mode

Command	Function	Command	Function
READ / RW	Weight Reading	CT	Tare Clearing
ZERO / MZ	Weight Re-zeroing	RI	Weight Accumulation
TARE / MT	Gross Weight Deducting	Rm	Times Accumulation
NTGS	Gross / Net Switch	Rn	Date
MG	Gross Weight Indicating	Ro	Time
MN	Net Weight Indicating	AT	Weight and Times Accumulation
		DT	Weight and Times Accumulation Clearing

- ❶ After setting above commands, it must add the termination code “CR (0DH) and LF (0AH)”.
- ❷ If the command is not correct, it shows “E” + “Command Unidentified”.
- ❸ If the command mode is chosen with address (RS1-01 = 4), add “@ address” in front of each command.

**Example:** When RS1-06 = 1, for reading weight value, the whole complete command should be “@01RW (CR) (LF)”.

---

---

# Chapter 6 Internal Calibration

Adjust calibration switch to “ON”, and the screen displays:

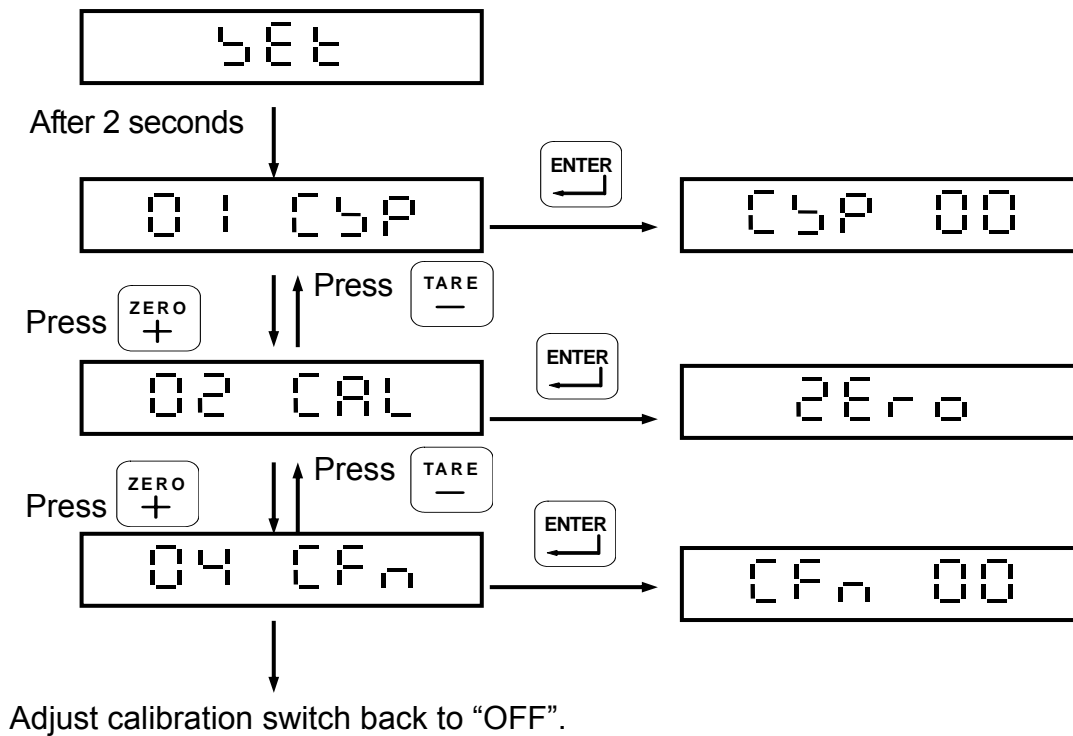

01 C5P ⇒ Specification Calibration

02 CAL ⇒ Weight Calibration

04 CFn ⇒ Internal Function Setting

## 6-1 0 1 C5P Specification Calibration

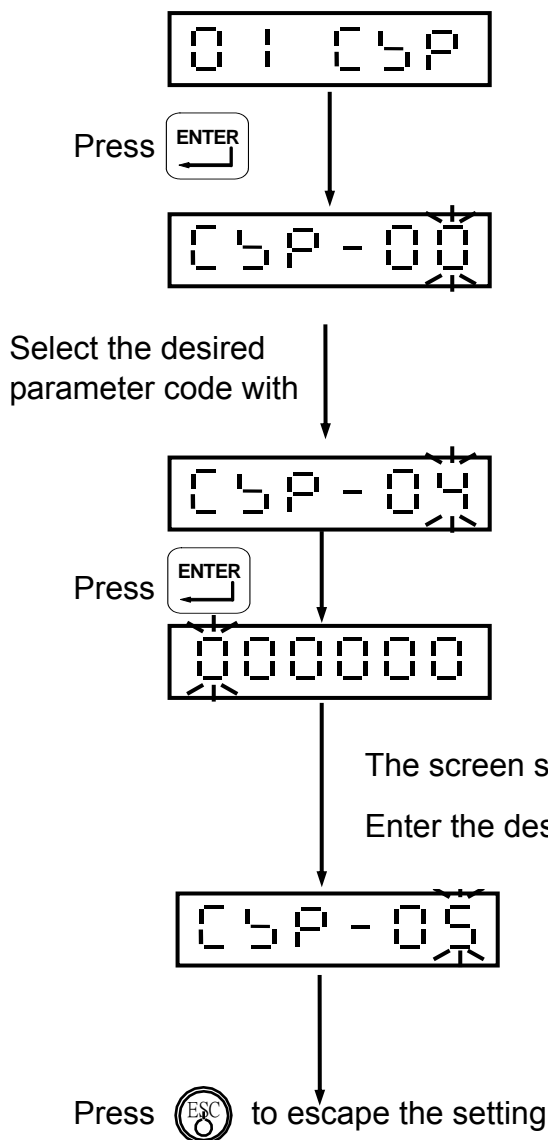

### Parameter Code

- C5P-00 ⇒ Decimal Point
- C5P-01 ⇒ Maximum Weighing Capacity
- C5P-02 ⇒ Division 1
- C5P-03 ⇒ Division 2
- C5P-04 ⇒ Zero Tracking Setting
- C5P-05 ⇒ Unstable Detection Setting

	⇒ Increase the flash value by one
	⇒ Decrease the flash value by one
	⇒ Move the cursor leftward
	⇒ Move the cursor rightward
	⇒ Save setting
	⇒ Abort setting or exit

## ☐ Specification Parameter Description

Parameter Code	Function	Setting Value		Default Setting
		Parameter	Description	
CSP-00	Decimal Point		Refer to descriptions in next page.	0
CSP-01	Maximum Weighing Capacity	999999 ↓ 000000	Max. value for weight display	999999
CSP-02	Division 1	1	Min. value for weight display	1
		2		
		5		
		10		
		20		
		50		
CSP-03	Division 2	1	Min. value for weight display	1
		2		
		5		
		10		
		20		
		50		
CSP-04	Zero Tracking Setting		Refer to descriptions in next page.	0.25d
CSP-05	Unstable Detection Setting		Refer to descriptions in next page.	0.25d

## Parameter Display Description

### CSP-00 Decimal Point

Display	Decimal Point Digit
d 0	None
d 00	1 digit
d 000	2 digits
d 0000	3 digits
d 00000	4 digits

### CSP-04 Zero Tracking Setting

Display	Division/Time
0.25 d	0.25 d / 1 s*
0.5 d	0.5 d / 1 s*
0.75 d	0.75 d / 1 s
1 d	1d / 1 s
1.25 d	1.25 d / 2 s
1.5 d	1.5 d / 2 s
1.75 d	1.75 d / 2 s
2 d	2 d / 2 s
no	No Zero Tracking

### CSP-05 Unstable Detection Setting

Display	Division / Time
0.25 d	0.25 d / 1 s*
0.5 d	0.5 d / 1 s*
0.75 d	0.75 d / 1 s
1 d	1d / 1 s
1.25 d	1.25 d / 2 s
1.5 d	1.5 d / 2 s
1.75 d	1.75 d / 2 s
2 d	2 d / 2 s
no	No Unstable Detection

The symbol "\*" is standard for OIML Certification in context.

---

---

## 6-2 O2 CAL Weight Calibration

Turn on and warm up the machine for 15 to 30 minutes before calibration.

Adjust the calibration switch to “ON”, and the screen will show **SEt**.

Press **TARE** or **ZERO** to select **O2 CAL**.

### Procedure

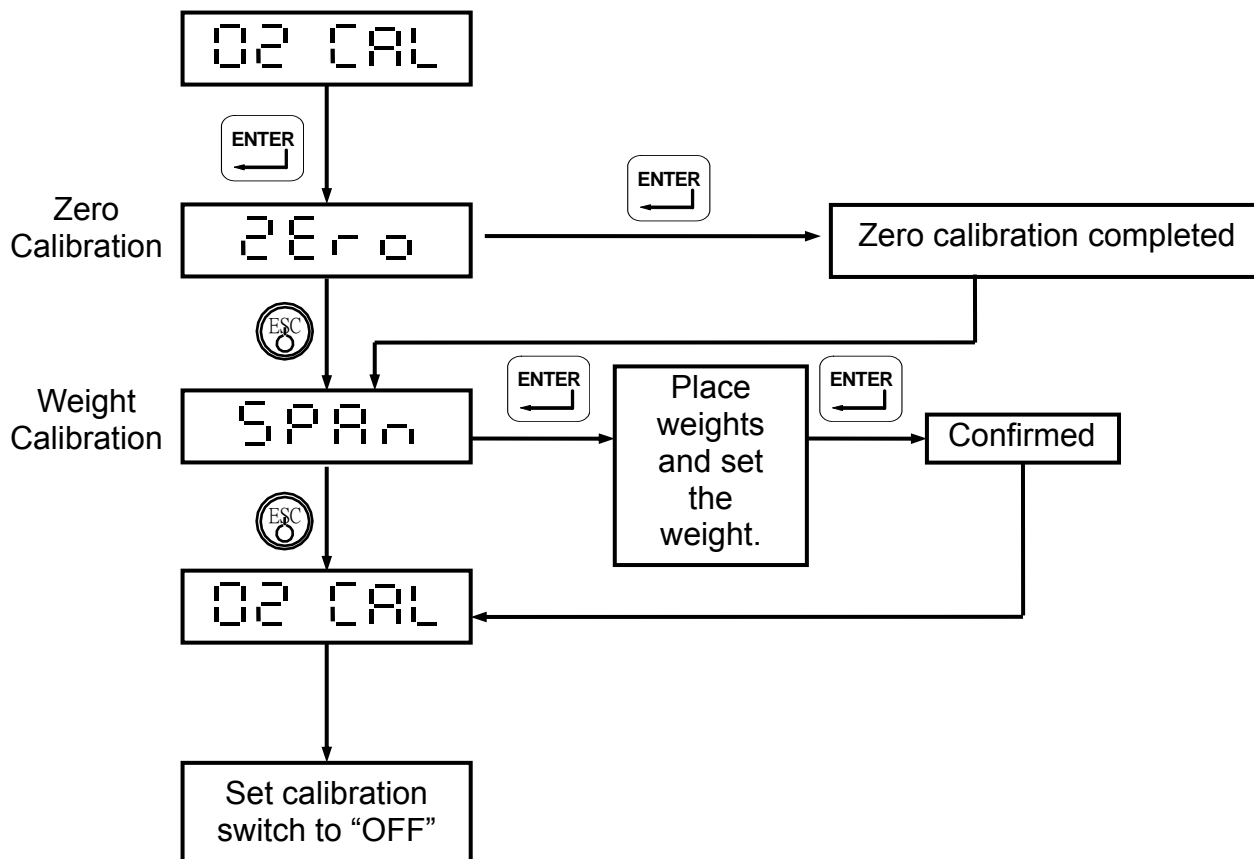

### Zero Calibration

- Ensure nothing on the platter. After the scale being stable, press **ENTER**, and the screen will display “.....”. The zero calibration will be completed after 5 seconds.
- To abort zero calibration, just press **ESC**.

### Weight Calibration

- Place an object which weight is known on the platter. Input the weight value and wait the scale to be stable, then press **ENTER**. The screen will show “-----”. The weight calibration will be completed after 5 seconds.
- To abort weight calibration, just press **ESC**.



---

---

## Password Setting

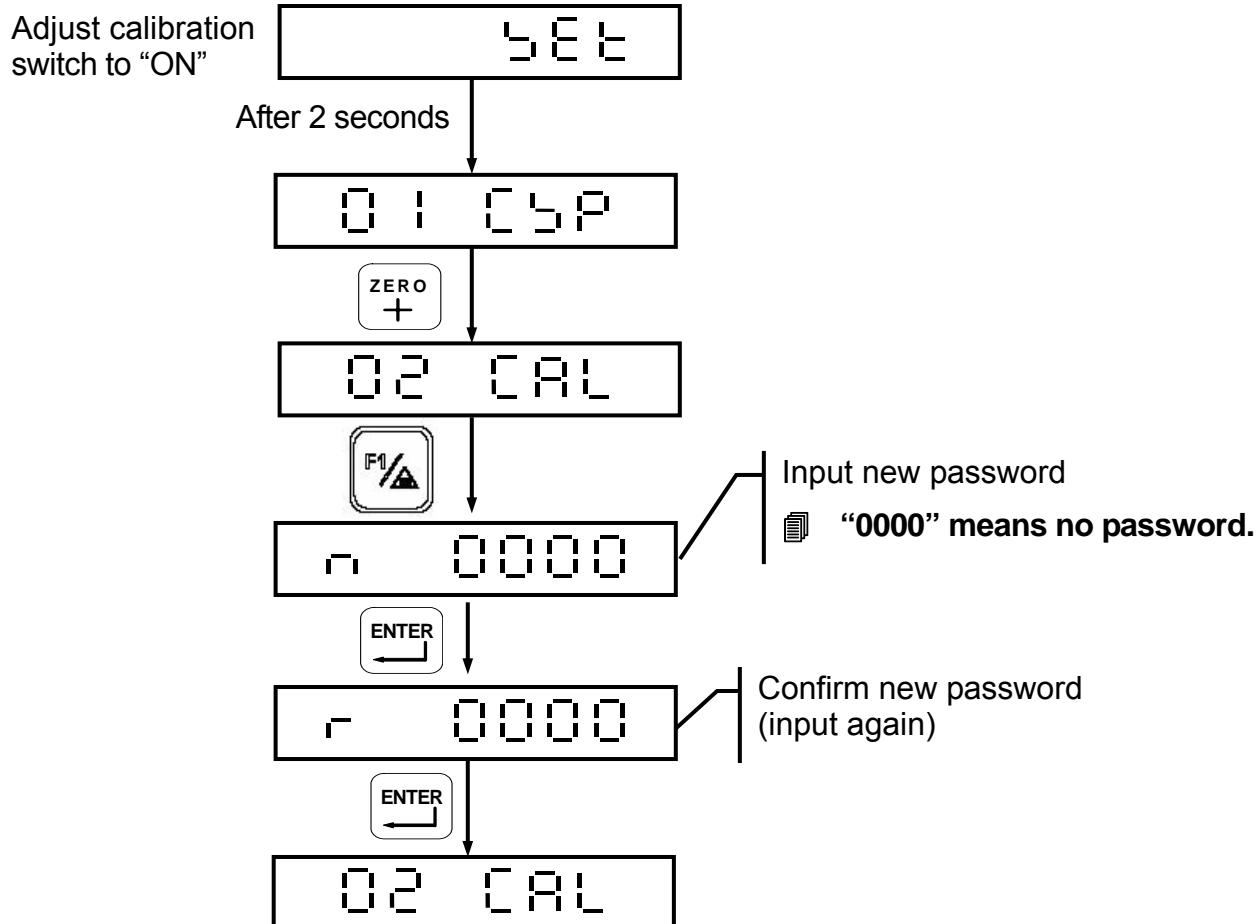

After complete password setting, when entering calibration mode or function setting mode, the screen shows  $P \bar{U}$  for 1 second, and then 0000. It's necessary to input the correct password to continue each setting.

If the input password is incorrect, the screen shows  $E r r$ .

## 6-3 04 [Fn] Internal Function Setting

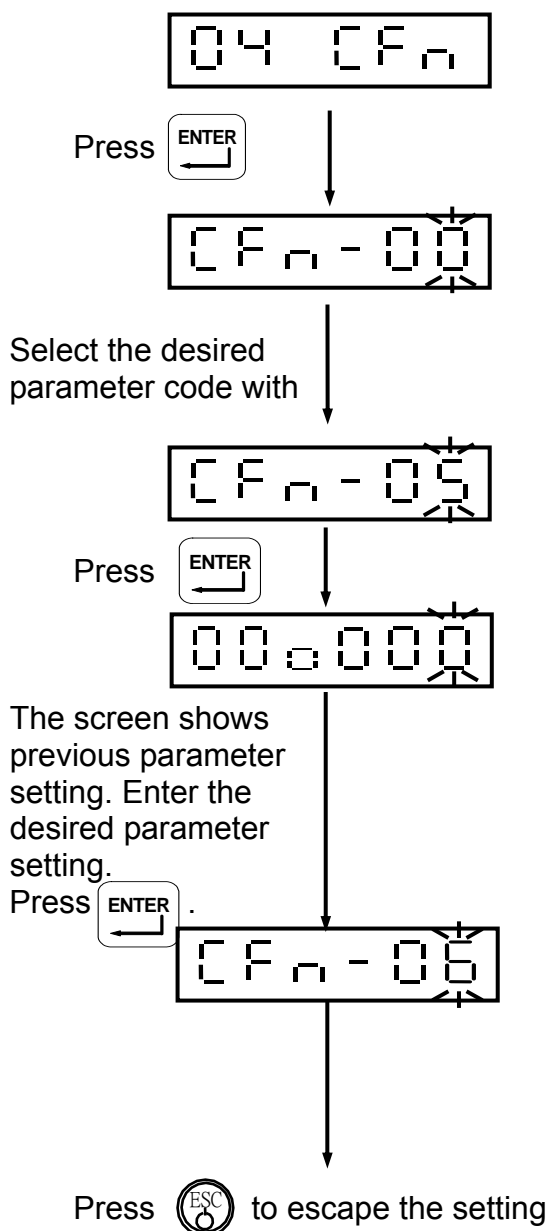

### Parameter Code

- [Fn-00] ⇒ Tare or Zero Function under Unstable Status
- [Fn-01] ⇒ Zero when Scale Turned on
- [Fn-02] ⇒ Back to Zero Range
- [Fn-03] ⇒ Filter Sampling Rate
- [Fn-04] ⇒ Filter Strength
- [Fn-05] ⇒ Animal Scale Mode
- [Fn-06] ⇒ Animal Scale Stable Range
- [Fn-07] ⇒ Animal Scale Sampling Frequency
- [Fn-08] ⇒ Dual Range Resolution Setting
- [Fn-09] ⇒ Midpoint Setting for Dual Range Resolution
- [Fn-10] ⇒ Gravity Calibration
- [Fn-11] ⇒ Operation of Accumulative Value/ Times upon Unstable Condition

## Internal Function Parameter Description

Parameter Code	Function	Setting Value		Default Setting
		Parameter	Description	
CFN-00	Tare or Zero Function under Unstable Status	0	ON	1
		1*	OFF	
CFN-01	Zero when Scale Turned on	0	OFF	1
		1	ON	
CFN-02	Back to zero range	0% ~ 30%	0%: Full range re-zero 1% ~ 30%: Capacity × ± setting value% <b>(The parameter is less than or equal to 2.) *</b>	2
CFN-03	Filter Sampling Rate	0 ~ 9	The larger number setting, the lower speed rate is.	6
CFN-04	Filter Strength	0 ~ 5	The larger number setting, the stronger filter is.	2
CFN-05	Animal Scale Mode	0	OFF	0
		1	Mode 1: The weight value won't be shown if the weighing condition is unstable.	
		2	Mode 2: The weight value shows in stable or unstable weighing condition.	
CFN-06	Animal Scale Stable Range	0 ~ 100%	Mode 2: Stable Range Setting <b>(The parameter is less than or equal to 10.) *</b>	10
CFN-07	Animal Scale Sampling Frequency	0	8 times	2
		1	16 times	
		2	32 times	
		3	64 times	
		4	128 times	
CFN-08	Dual Range Resolution Setting	0	Multi - interval	0
		1	Multi - range	
CFN-09	Midpoint Setting for Dual Range Resolution	0 ~ 999999	Set the demarcation point for dual range resolution.	5 000
CFN-10	Gravity Calibration	9.78032   9.83218	Gravity calibration for the different using & production zone.	9.79423
		1	Zero when Scale turned on.	
CFN-11	Operation of Accumulative Value/ Times upon Unstable Condition	0	ON	1
		1*	OFF	

The symbol "\*" is standard for OIML Certification in context.

---

---

## 6-4 Error Messages

- |           |   |
|-----------|---|
| (1) Err 0 | Load Cell or A/D circuit is abnormal.                     |
| (2) Err 2 | Real weighing value is lower than or equal to zero value. |
| (3) Err 5 | Internal resolution is lower than 0.15 $\mu$ V/d range.   |
| (4) Err.  | Incorrect password  |
| (5) E 1   | Internal value is lower than zero range.                  |
| (6) E 2   | Internal value is higher than zero range.                 |

---

---

# Chapter 7 Special Function

## 7-1 Animal Scale Setting

### ☐ CFN-05 = 1

(Animal Scale Mode1: The weight value won't be shown if the weighing condition is unstable.)

When there is nothing on the platter, the screen will show:

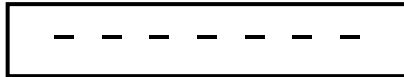

When an object is on the platter, take a 20-gram object for example, the screen will show:

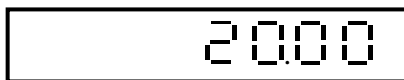

The weight value will be kept on the display if the weight is lower than 10d or you can push "Enter" key to reset weighing process, then the screen will show:



### ☐ CFN-05 = 2

(Animal Scale Mode 2: The weight value shows in stable or unstable weighing condition The weight value shows on the display under the stable or unstable weighing condition.)

When the weight value reaches the range of CFN-06 and CFN-07 setting, the screen will keep showing the weight value.

When the weight value is over the range of CFN-06 and CFN-07 setting, the screen will show the normal weight measurement.

For example: CFN-06=30      CFN-07=2

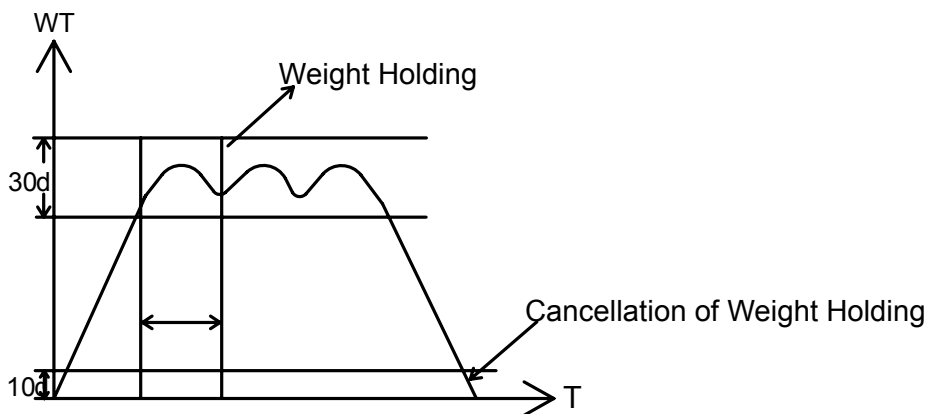

---

---

## 7-2 Dual Range Resolution Switch Function

The dual range resolution will be available when the parameter settings of CSP-02 and CSP-03 are different.

### **CFN-08 = 0 Multi - interval**

If CFN-09 = 5 000

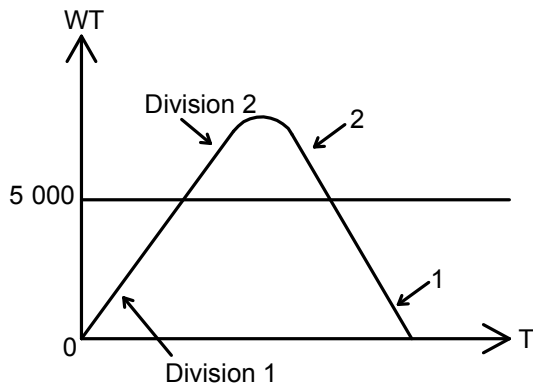

### **CFN-08 = 1 Multi - range**

If CFN-09 = 5 000

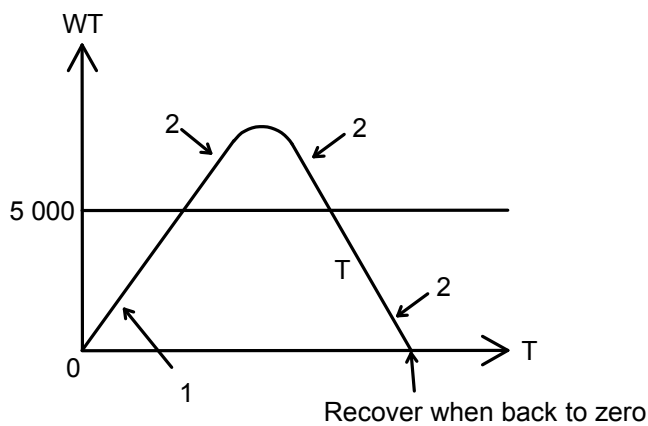



---

---

## 7-3 Pre-Tare Function

☐ FNC-02 or FNC-03 setting is at parameter 6. (Pre-Tare Function)

Under weight display status, press  or  key (according to FNC setting), the screen will show:

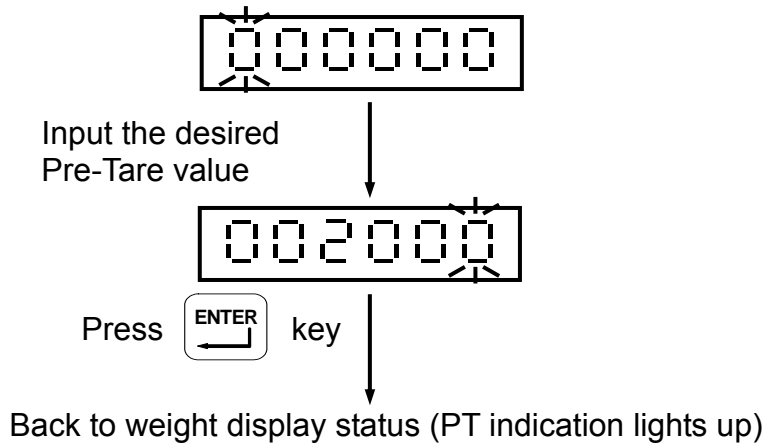

## Pre-Tare Cancellation

When the gross weight column shows "0", press  key to cancel the Pre-Tare value.

## 7-4 Resolution Switch Function

☐ FNC-02 or FNC-03 setting is at parameter 5.

Under weight display status, press  or  key (according to FNC setting), the display will show 10 times of the original division value and it will return back to the original one after 5 seconds.

---

---

## 7-5 Maintain Beeper Value Setting

### Mode 1

RS-232 transmission mode enters into HOLD value transmission mode automatically. When the weight is higher than 10d, the indicator holds the max value of weight. Press  key to unlock HOLD mode.

RS-232 transmits one data of PEAK of HOLD value when press  .

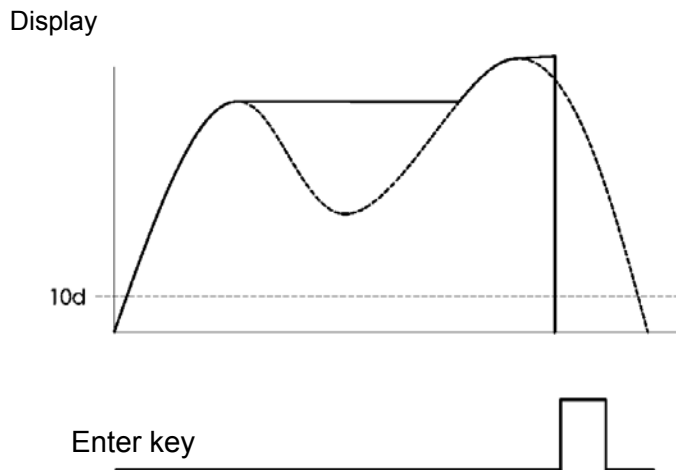

### Mode 2

RS-232 transmission mode enters into HOLD value transmission mode automatically.

When the weight is higher than 10d, the indicator holds the max value of weight.

When the weight is lower than 10d, the indicator unlocks HOLD value automatically and shows the weight value which is lower than 10d.

RS-232 transmits one data of PEAK HOLD value. The data point is from PEAK HOLD value to lower than 10d.

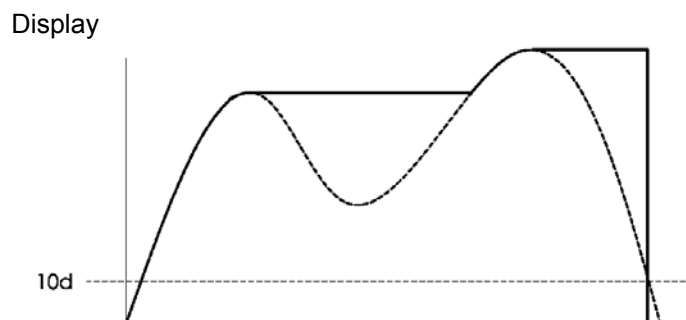



---

---

# Chapter 8 Interface

## 8-1 OP-01 RS-232 / RS-485 Serial Output with RTC (Real Time Clock)

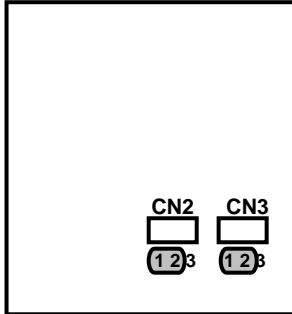

Short 1 and 2 pins to get RS-485 output.

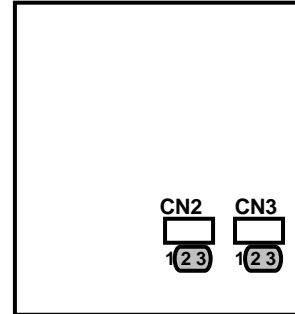

Short 2 and 3 pins to get RS-232 output.

### Pin Allocation of Rear Panel

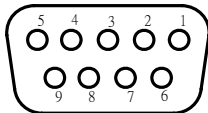

Pin	Function
2	RXD
3	TXD
5	SG
6	DA
7	DB

 RS-485 interface is capable to connect up to 10 mini-indicators.

---

---

## Connection Description (RS-485)

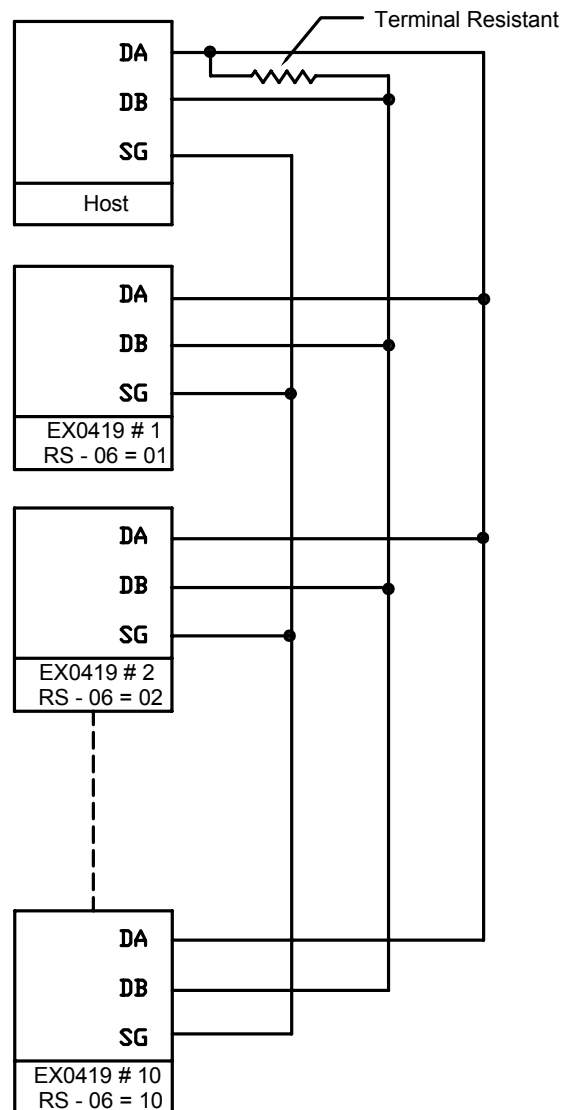

### Notice

- ◆ If the terminal resistor is built-in the host interface, it's not necessary to connect with another one from outside.
- ◆ If the host computer is no signal ground (SG), it's not necessary to connect with it.

---

---

# Chapter 9 Maintenance

## 9-1 Restore Default Setting for All Parameters (General Certification)

(1) Adjust the calibration switch to “ON” during the countdown of power on, press



and hold them simultaneously.

(2) The screen will show `In It . ALL`

(3) To confirm, press  and hold until showing `End`, and then adjust the calibration switch to “OFF”.

## 9-2 Restore Default Setting for All Parameters (OIML Certification)

(1) Adjust the calibration switch to “ON” during the countdown of power on, press

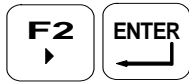

and hold them simultaneously.

(2) The screen will show `In It . ALL`

(3) To confirm, press  and hold until showing `End`, and then adjust the calibration switch to “OFF”.

## 9-3 Restore Default Setting for General Function Parameters

(1) Press  and hold simultaneously during the countdown of power on.

(2) The screen will show `In It . Fn`

(3) To confirm, press  and hold until re-turning on.

## 9-4 Self-test Mode

(1) Press  and hold it during the countdown of power on.

(2) The screen will show `U E r`, which means entered self-test mode.

(3) Use  or  keys to select test program.

Press  key to enter self-test, and press  key to exit.

Item	Display	Testing Item
1	0Er	Program Version Number Displaying
2	d5P	7-Segment Display Testing
3	EEY	Keypad and Calibration Switch Testing
4	AdC	A/D Conversion Value Displaying
5	EEP	EEPROM Testing
6	rEC	RTC Date & Time Testing
7	232	OP-1 RS-232 Serial Output Interface Testing

---

---

### 9-4-1 Program Version Number

7-Segment display shows program version number XXXXXX.



Press  again to show

1	: General certification
2	: OIML certification
3	: No meaning

### 9-4-2 7-segment Display Testing

7-Segment display shows  to  and “.”.

### 9-4-3 Keypad & Calibration Switch Testing

Adjust calibration switch to “ON”, and press any key, the corresponding bit will be changed from  to .

### 9-4-4 A/D Conversion Value

7-Segment display shows the internal value of the scale.

### 9-4-5 EEPROM Testing

Showing  represents in normal condition.

Showing  represents in abnormal condition.

### 9-4-6 RTC Time & Date Testing

Press  key to enter the testing mode, and the screen will show date YY.MM.DD.

For example: “05.11.03” represents 3rd of November, 2005.

Press  key again to show time HH.MM.SS.



For example: “09.45.50” represents 9 o'clock, 45 minutes and 50 seconds.

### 9-4-7 RS-232 Serial Output Interface Testing ( OP - 01 )

(1) Short Pin 2 and Pin 3 of the 9-pin D-SUB socket of serial output.

Showing  represents in normal condition.

Showing  represents in abnormal condition.

(2) If connected with a computer (protocol must be corresponding), the screen will show  to , which means RS-232 output is in normal condition.

# Appendix 7-Segment Display Characters

Number	Display	Letter	Display	Letter	Display
0		A		N	
1		B		O	
2		C		P	
3		D		Q	
4		E		R	
5		F		S	
6		G		T	
7		H		U	
8		I		V	
9		J		W	
		K		X	
		L		Y	
°C		M		Z	



