

Operating instructions

METTLER TOLEDO MultiRange ID7sx-Base weighing terminal

METTLER TOLEDO

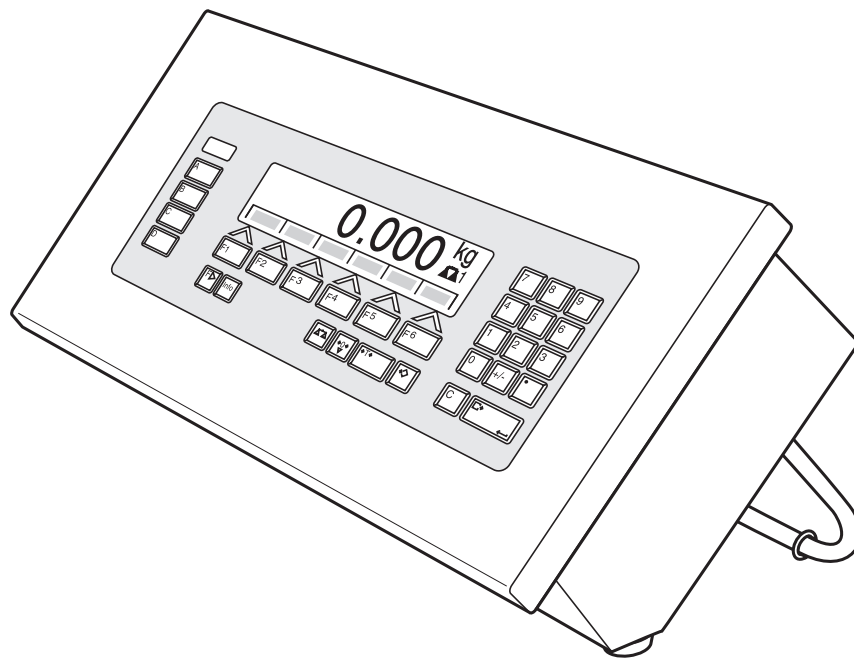

These operating instructions 22008168A describe the following components:

ID7sx-Base

IDNet-ID7sx (1 x standard)

CL20mA-ID7sx (1 x standard)

RS232-ID7sx

8 I/O-ID7sx

Memory-ID7sx

Profibus-DP-ID7sx

Contents

	Page
1 Introduction and commissioning	3
1.1 Safety precautions	3
1.2 Applications	4
1.3 ID7sx-Base weighing terminal	5
1.4 Commissioning	6
1.5 Cleaning	8
2 Basic functions	9
2.1 Setting to zero	9
2.2 Taring	9
2.3 Weighing	10
2.4 Switch over weighing platform	11
3 Additional functions	12
3.1 Weighing with the DeltaTrac	12
3.2 Dynamic weighing	15
3.3 Change weight unit	15
3.4 Working in a higher resolution	16
3.5 Display gross weight	16
3.6 Specifying dynamic set points	16
3.7 Multiplicative tare function	17
3.8 Additive tare function	17
3.9 Sandwich tare	17
3.10 Display ID code and test weighing platform	18
3.11 Identifications	18
3.12 Recall information	19
3.13 Print or transfer data	20
3.14 Enter values with barcode reader	21
3.15 Working with a second display	21
3.16 Recall data from memory module	23
4 Settings in the master mode	26
4.1 Overview of the master mode	26
4.2 Operating the master mode	27
4.3 TERMINAL master mode block	29
4.4 SCALE master mode block	35
4.5 INTERFACE master mode block	38
5 Interface description	51
5.1 MMR command set	51
5.2 METTLER TOLEDO continuous mode	61
5.3 METTLER TOLEDO SICS command set	63
5.4 Profibus-DP – communication with a PLC	78

6	Application blocks	87
6.1	Syntax and formats.....	87
6.2	TERMINAL, SCALE application blocks.....	90
6.3	INTERFACE application blocks.....	94
7	What to do if ...?.....	96
8	Technical data and accessories.....	99
8.1	Technical data	99
8.2	Accessories	103
9	Appendix	105
9.1	ASCII table	105
10	Index.....	106

1 Introduction and commissioning

1.1 Safety precautions



The ID7sx-Base weighing terminal is approved for operation in zone 1 and 21 hazardous areas. It may only be used in areas in which the causes of static electricity build-up, which lead to propagating brush discharges, have been eliminated.

If the ID7sx-Base weighing terminal is used in hazardous areas, special care must be taken. The code of practice is oriented to the "Safe Distribution" concept drawn up by METTLER TOLEDO.

- Competence** ▲ The weighing system may only be installed, maintained and repaired by authorised METTLER TOLEDO service personnel.
- Ex approval** ▲ No modifications may be made to the terminal and no repair work may be performed on the modules. Any weighing platform or system modules that are used must comply with the specifications contained in the installation instructions. Non-compliant equipment jeopardises the intrinsic safety of the system, cancels the Ex approval and renders any warranty or product liability claims null and void.
- ▲ The safety of the weighing system is only guaranteed when the weighing system is operated, installed and maintained in accordance with the respective instructions.
- ▲ Also comply with the following:
- the instructions for the system modules
 - the regulations and standards in the respective country
 - the statutory requirement for electrical equipment installed in hazardous areas in the respective country
 - all instructions related to safety issued by the owner
- ▲ The explosion-protected weighing system must be checked to ensure compliance with the requirements for safety before being put into service for the first time, following any service work and every 3 years, at least.
- Operation** ▲ Prevent the build-up of static electricity. Always wear suitable working clothes when operating or performing service work in a hazardous area.
- ▲ Do not use protective coverings for the device.
- ▲ Avoid damage to the system components.

1.2 Applications

The ID7sx-Base weighing terminal can be operated with the PSU or PSUx power supply unit.

1.2.1 ID7sx-Base with PSU power supply unit

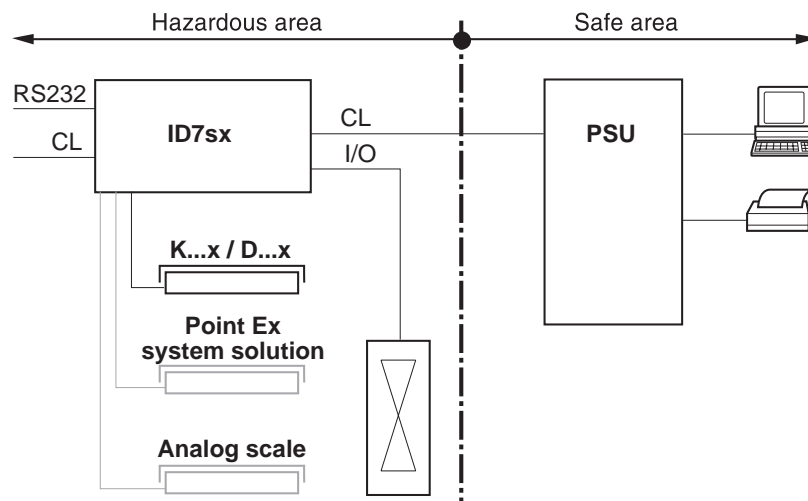

In this configuration the following possibilities are available:

- Multi-scale operation with up to 3 weighing platforms (K...x, D...x or Point Ex system solution)
- Up to 3 data interfaces and one I/O interface
 - for printing,
 - for data exchange with a computer,
 - for control, e.g. of valves or flaps.
- Memory module for storing the individual configuration data as well as weighing data.

1.2.2 ID7sx-Base with PSUx power supply unit

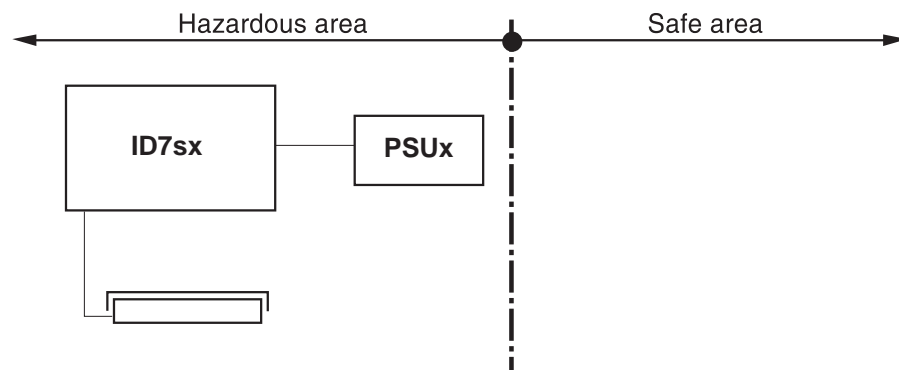

Only one weighing platform (K...x, D...x with Point Ex A/D converter or Point Ex system solution) is permissible in this configuration.

1.3 ID7sx-Base weighing terminal

1.3.1 Display

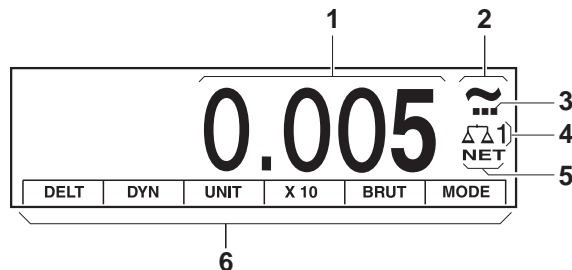

- 1 Weight display with sign and decimal point
- 2 Stability monitor: lights up until the weighing platform has levelled out, then the weight unit appears here
- 3 Range display for multi-range weighing platforms
- 4 Number of the weighing platform: shows the weighing platform just selected
- 5 NET symbol for marking net weight values
- 6 Assignment of the function keys

1.3.2 Keypad

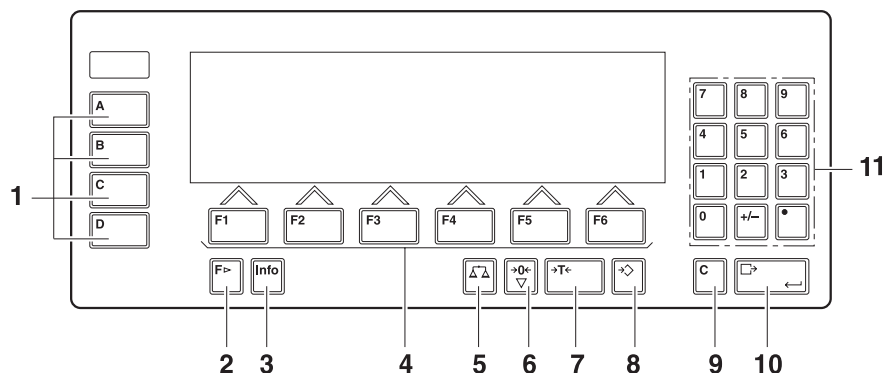

- 1 CODE A ... CODE D keys – enter identification data
- 2 FUNCTION CHANGE key – display additional functions when entering weight values: switch over unit
- 3 INFO key – recall memory contents and system information
- 4 Function keys F1 ... F6 – the current assignment is shown in the display above the key
- 5 SCALE key – select scale
- 6 ZERO-SET key – set scale to zero, test scale
- 7 TARA key – tare scale
- 8 TARE SPECIFICATION key – enter known tare values numerically
- 9 CLEAR key – clear entries and values
- 10 ENTER key – accept and transfer data
- 11 Numeric keypad with decimal point and signs

1.4 Commissioning

1.4.1 Control drawings and guides for installers

The explosion-protected weighing system with the ID7sx-Base weighing terminal may only be installed according to the respective guide for installers and the accompanying control drawing, depending on the power supply unit.

Component	Guide for installers	Control drawing
ID7sx	ME-22008316	PSU-ID7sx ME-22006478
PSU	ME-22006472	
PSUx/230V	ME-22006386	PSUx/230V-ID7sx ME-22006397
PSUx/120V	ME-22006395	PSUx/120V-ID7sx ME-22006399

1.4.2 Marking and sealing of certified weighing platforms

ID code With the ID code it can be checked whether certified weighing platforms have been tampered with since the last certification. The ID code can be displayed on the terminal at any time, see section 3.10.

During certification the currently displayed ID code is recorded and sealed.

During each change to the configuration the displayed ID code increases. It then no longer matches the sealed ID code; the certification is not longer valid.

Certification To mark and certify your weighing system, please contact METTLER TOLEDO Service or your local board of weights and measures.

Check certification

1. Display ID code, see section 3.10; press ZERO-SET key until IDENTCODE = ... is displayed.
No value is shown for noncertified weighing platforms, but instead:
IDENTCODE ===.
2. Compare ID code displayed with sealed ID code on ID card.
The certification of the weighing system is only valid when both values are identical.

Table version

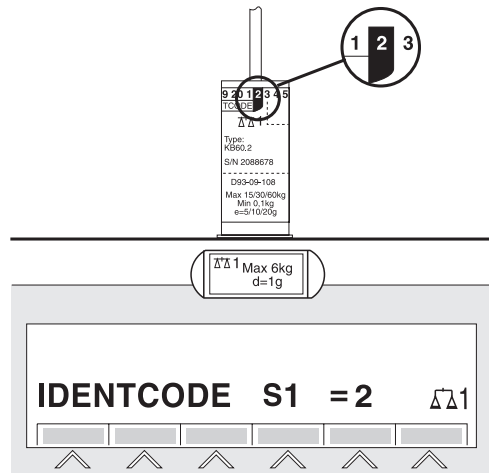

Panel version

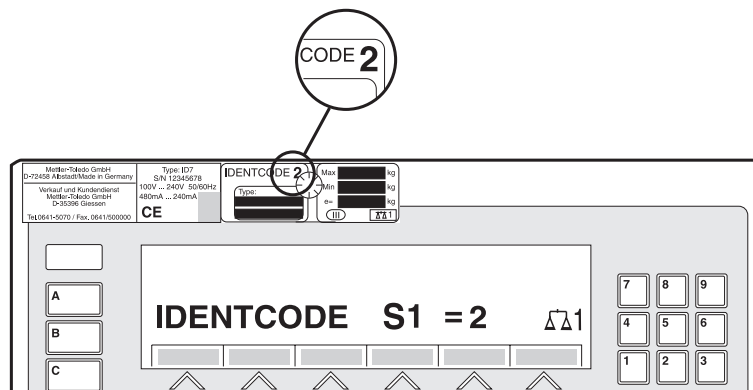

- Press ZERO-SET key again.
The connected weighing platform is checked. The display shows CHECK SCALE and after the test is completed SCALE IS OK.
Then the ID7sx-Base automatically returns to normal operation.

1.5 Cleaning



DANGER OF SHOCK

→ Do not open ID7sx-Base weighing terminal to clean.

CAUTION

→ Make sure that unused connection sockets are covered with the corresponding protective caps. Ensure the correct position of the seals when doing so.

→ Do not use high-pressure cleaners.

Cleaning

→ Wipe off ID7sx-Base weighing terminal with a commercially available glass or plastic cleaner.

→ When used in category 2, zone 21 hazardous areas, the weighing terminal must be cleaned regularly. See also standard EN 50281-1-1 / 50281-1-2.

2 Basic functions

2.1 Setting to zero

Setting to zero corrects the influence of minor dirt on the load plate.
In the case of excessive dirt which cannot be compensated by setting to zero, the display shows OUT OF RANGE.

Manual zero set

1. Relieve weighing platform.
2. Press ZERO-SET key.
The display shows 0.000 kg.

Automatic zero set

On certified weighing platforms the zero point of the weighing platform is automatically corrected when the weighing platform is relieved.
The automatic zero set can be switched off in the master mode on noncertified weighing platforms.

2.2 Taring

2.2.1 Manual taring

1. Place empty container on scale.
2. Press TARE key.
The tare weight is saved and the weight display set to zero.
The display shows the NET symbol.

Notes

- When the weighing platform is relieved, the saved tare weight is displayed with a negative sign.
- The weighing platform only saves **one** tare value.

2.2.2 Automatic taring

Prerequisite

AUTOTARA ON must be set in the master mode, see section 4.4.

- Place empty container on scale.
The container weight is automatically saved and the weight display set to zero.
The display shows the NET symbol.

Note

When the weighing platform is relieved, the saved tare weight is cleared.

2.2.3 Specify tare weight

Enter numerically

1. Press TARE SPECIFICATION key.
2. Enter tare weight (container weight) and confirm with ENTER.
When weighing platform is relieved, the entered tare weight is displayed with a negative sign.

Note

With the FUNCTION CHANGE key you can select the weight unit for entering the tare weight.

Correct entry

→ Clear the entry character by character with the CLEAR key and repeat correctly.

Copy tare constant

The ID7sx-Base has 999 tare memories for frequently used tare weights programmed in the master mode.

1. Enter memory number: 1... 999.
2. Press TARE SPECIFICATION key.
The display shows the NET symbol and the net weight based on the recalled tare weight.

2.2.4 Recall currently saved tare weight

The saved tare weight can be recalled at any time.

- Enter INFO, TARE SPECIFICATION key sequence.
The saved tare weight is displayed.

2.2.5 Clear tare weight

- Relieve weighing platform and tare.
– or –
→ Specify tare weight 0.
– or –
→ Enter TARE SPECIFICATION, CLEAR key sequence.

2.3 Weighing

Weighing without taring

- Lay weighing sample on weighing platform.
Gross weight (total weight) is displayed.

Weighing with taring

1. Place the empty container on the weighing platform and tare.
2. Pour in weighing sample.
The display shows the net weight and the NET symbol.

Weighing with tare specification

1. Place filled container on weighing platform.
The display shows the gross weight (total weight).
2. Specify tare weight or recall tare memory.
The display shows the net weight (container content) and the NET symbol.

Note

If a **multi-range weighing platform** is chosen, a display for the currently active range appears above the scale symbol.

2.4 Switch over weighing platform

Up to 3 weighing platforms can be connected to the ID7sx-Base.
The weighing platform currently selected is shown on the terminal.

→ Press SCALE key.

The next weighing platform is selected.

– or –

→ Enter number of weighing platform and press SCALE key.

The desired weighing platform is selected.

3 Additional functions

The assignment of the 6 function keys of the ID7sx-Base weighing terminal differs depending on the weighing task. The current assignment is shown above the function keys.

With the FUNCTION CHANGE key it is possible to switch over to other function key assignments.

Independent of the application software, the ID7sx-Base has the following additional functions:

DELT	DYN	UNIT	X 10	GROSS	MODE
Weighing with the DeltaTrac, see 3.1	Dynamic weighing, see 3.2	Change weight unit, see 3.3	Increase resolution, see 3.4. This key is not assigned when the control mode is continually switched on.	Display gross weight, see 3.5	Activate master mode, see Chapter 4

MULT-TARE	ADD-TARE	SANDWICH-T
Multiplicative tare function, see 3.7	Additive tare function, see 3.8	Sandwich tare, see 3.9

If at least one dynamic switching point is configured in the master mode (see page 48), the second row of function keys is given the following assignment:

SETP			MUL-T	ADD-T	SW-T
Set dynamic set points, see 3.6			Multiplicative tare function, see 3.7	Additive tare function, see 3.8	Sandwich tare, see 3.9

3.1 Weighing with the DeltaTrac

The DeltaTrac is an analog display which makes it easier to read the weighing results.

In the master mode you can select how the DeltaTrac is displayed for the various weighing tasks FILLING, CLASSIFYING or CHECKWEIGHING.

Note

With the DeltaTrac signals you can also control lamps, flaps or valves, see section 4.5.3.

Application FILLING

For weighing-in to a target weight with tolerance monitoring.

Example: Target weight = 1.000 kg, tolerance = 1 %

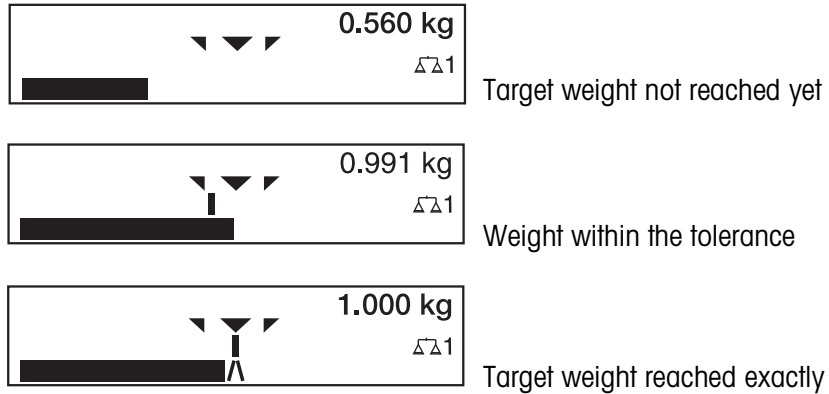

Application CLASSIFYING

To evaluate test samples as OKAY, TOO LIGHT or TOO HEAVY, based on a target weight and specified +/- tolerances.

Example: Target weight = 1.000 kg, tolerance = 1 %

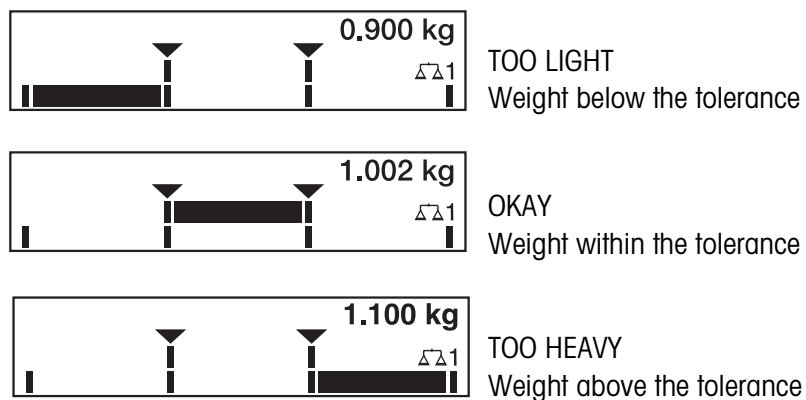

Application CHECKWEIGHING

For determining the difference between the target and actual weight.

Example: Target weight = 1.000 kg, tolerance = 1 %

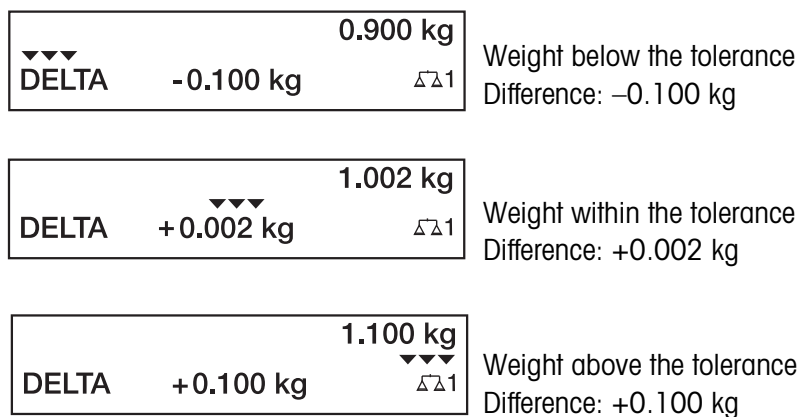

3.1.1 Preset DeltaTrac target values

- Enter numerically**
1. Press DELT key.
 2. Enter target weight and confirm with ENTER.
 3. Enter tolerance in % of target weight and confirm with ENTER.

Note

With the FUNCTION CHANGE key you can select the weight unit for entering the DeltaTrac target values.

Correct entry → With the CLEAR key the entry is corrected character by character.

Copy constants The ID7sx-Base weighing terminal has 999 DeltaTrac memories for frequently used target values and tolerances, which are programmed in the master mode.

1. Enter number of DeltaTrac memory: 1 ... 999.
2. Press DELT key.

- Reference sample**
1. Press DELT key.
 2. Lay sample on weighing platform and confirm with SCALE key.
 3. Only for FILLING and CLASSIFYING: Enter tolerance and confirm with ENTER.
 4. Remove sample from weighing platform.

Limits	Minimum target value	40 Digit
	Maximum target value	configured maximum load
	Minimum tolerance	1 Digit
	Maximum tolerance	10 % for the applications FILLING, CHECKWEIGHING 50 % for the application CLASSIFYING

Note

If the limits are not observed, a message appears in the display, e.g. MIN-DEL = ..., for too small a target value.

Clear DeltaTrac target value → Press DELT CLEAR key sequence.
DELTA CLEARED appears briefly in the display, then the weight is shown.

3.2 Dynamic weighing

With the dynamic weighing function you can weigh restless weighing samples, e.g. live animals. To do this, specify the number of weighing cycles for which the mean weight value is to be taken.

1. Set container on the weighing platform.
2. Tare weighing platform.
3. Place weighing sample in container.
4. Press DYN key and enter number of weighing cycles.
Possible values: 1 ... 255.
5. Start dynamic weighing with ENTER key.
6. After cycle time has expired, center line of display shows:
RESULT x.xxxx kg.
This display is retained until the next weighing is started or until it is cleared.

Delete result → Press CLEAR key.

Notes

- Dynamic weighing results are automatically printed when AUTO PRINT is set in the master mode, see section 4.3.2.
- Dynamic weighing can also be started with the interface command AW016..., see section 6.2.

3.3 Change weight unit

If an additional, second weight unit is configured in the master mode, it is possible to switch back and forth between the two weight units.

- Press UNIT key.
The weight value is shown in the second unit.

Note

Possible second weight units are: mg, g, kg, lb, oz, ozt, dwt.

3.4 Working in a higher resolution

Depending on the setting of the master mode block CONTROL MODE (see page 32), the weight value can be displayed in a higher resolution continuously or when called. Weight values in a higher resolution are marked with a *.

Displaying weight values in higher resolution

- Press X 10 key.
 - The weight value is displayed in at least a 10x higher resolution.
 - The higher resolution is displayed until the X 10 key is pressed again.

Note

With certified weighing platforms, the weight value only appears in a higher resolution as long as the X 10 key is pressed.

3.5 Display gross weight

The gross weight can only be displayed when a tare weight has been saved.

- Press GROSS key and hold down.
 - The gross weight is displayed.

3.6 Specifying dynamic set points

Conditions

- 8 I/O-ID7sx interface installed and connected.
- SETPOINT MODE ON and at least one dynamic set point is configured in the master mode.

Use If the specified set point values are exceeded or dropped below, digital outputs are set, e.g. for controlling lamps, flaps, valves etc. Dynamic set points can be set for each weighing procedure individually. The set points are retained until they are overwritten with a new value or deleted.

Specifying set points

1. Press the SETP key; the entry prompt for the first dynamic set point appears.
2. Enter the desired weight value and confirm with ENTER.
3. If additional dynamic set points are configured, the entry prompt appears for the next dynamic set point.
4. Enter the desired weight value and confirm with ENTER.
5. Repeat the procedure until all set points have been entered.

Deleting set points

- Press the SETP key and delete the value with the CLEAR key.

3.7 Multiplicative tare function

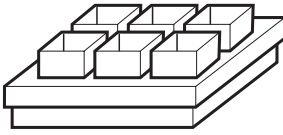

The multiplicative tare function is particularly suitable when pallets with identical containers are filled. If the number of containers and tare of the individual container are known, the ID7sx-Base weighing terminal calculates the total tare.

1. Press MULT TARE key.
2. Enter known tare weight of individual container and confirm with ENTER.
3. Enter number of containers and confirm with ENTER.
When the weighing platform is relieved, the total tare value is shown in the display with a negative sign.

Note

With the FUNCTION CHANGE key you can select the weight unit for entering the tare weight.

3.8 Additive tare function

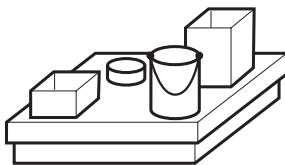

With the additive tare function you can subtract the tare of additional containers with a known tare weight for related weighings, e.g. if containers with different weights are filled on one pallet.

1. Place container on scale and press ADD TARE key.
2. Enter known tare weight and confirm with ENTER.
The total net weight appears in the weight display.

Note

With the FUNCTION CHANGE key you can select the weight unit for entering the tare weight.

3.9 Sandwich tare

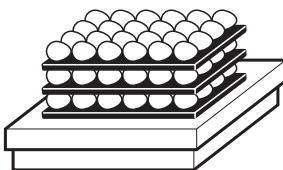

With the sandwich tare function you can detect additional tare weights for related weighings without losing the total gross and total net.

Example

In production or shipping boxes are laid between individual layers in the transport container. The weight of these boxes can be subtracted with this function.

1. Press SANDWICH-T key.
2. Place sandwich tare, e.g. box, on scale and confirm with ENTER.
The net weight is retained.

3.10 Display ID code and test weighing platform

Each time the weighing platform configuration is changed the ID code counter is increased by 1. On certified weighing platforms the displayed ID code must match the ID code on the ID code sticker, otherwise the calibration is no longer valid.

Display ID code

→ Press ZERO-SET key and hold until IDENTCODE = ... appears in the display and press again.

Test weighing platform

→ Press ZERO-SET key again.
The connected weighing platform is checked. The display shows CHECK SCALE and then SCALE IS OK after completing the test.

Note

If weighing platform is defective, display shows SCALE ERROR.

3.11 Identifications

The ID7sx-Base weighing terminal is equipped with 4 identification data memories for storing identification data Code A ... Code D.

The memories have a name, e.g. Article No., and a content which identifies the current weighing, e.g. 1234567.

The memories are named in the master mode, and the names can be noted on the keyboard. When the CODE keys are pressed, the name appears in the display.

Identification data Code A ... Code D can be entered or recalled for each weighing and are printed immediately.

3.11.1 Enter identification

An identification may contain a maximum of 30 characters.

Enter numerical identification

1. Press one of the keys CODE A ... CODE D.
2. Enter identification data Code A ... Code D via the numeric keypad and confirm with ENTER.

Enter alphanumeric identification

1. Press one of the keys CODE A ... CODE D.
The function keys are given the following assignment:

ABCDE	FGHIJ	KLMNO	PQRST	UVWXY	Z/(-)
Selection of letters A to E	Selection of letters F to J	Selection of letters K to O	Selection of letters P to T	Selection of letters U to Y	Selection of letter Z and special characters

2. Select desired group of letters, e. g. press KLMNO key.
3. Select desired letter.
The display changes again to the above selection.
4. Repeat entry in steps 2 and 3 for additional characters.

Note

Letters and numbers can be combined as desired.

Recall fixed text memory

The ID7sx-Base weighing terminal is equipped with 999 memories for fixed texts which can be programmed in the master mode and used as identifications.

1. Enter memory number: 1 ... 999.
2. Press a key CODE A ... CODE D.
The saved fixed text is now assigned to the selected identification Code A ... Code D.

3.11.2 Clear identifications

→ Press desired key CODE A ... CODE D and clear memory content with CLEAR key.

3.12 Recall information

On the ID7sx-Base weighing terminal memory contents and system information can be recalled.

1. Press INFO key.
Then the following function key assignment appears:

DELT	TARE	TEXT	ALIBI	DATE	VERS
Display DeltaTrac values	Display tare weight	Display fixed texts and name of keys CODE A ... CODE D	Recall content of alibi memory. This selection only appears when Memory-ID7sx is installed.	Display date and time	Display version numbers of installed software modules

2. Select desired information.
The information is displayed for approx. 5 seconds, then the ID7sx-Base changes to the weighing mode again.

Notes

- When several values are displayed, the ID7sx-Base automatically changes to the next value after approx. 5 seconds.
- With the CLEAR key it is possible to switch to the next value or back to the weighing mode.

3.12.1 Recall memory

1. Press INFO key.
2. Enter number of memory and press DELT, TARA or TEXT key depending on desired memory.

Recall name of CODE A ... CODE D keys

1. Press INFO key.
2. Press one of the keys CODE A ... CODE D.
The display shows the current Code.

3.13 Print or transfer data

If a printer or computer is connected, weighing results can be printed out or transferred to the computer.

In the master mode you can set the following for this purpose:

- Data to be printed or transferred,
- Manual or automatic data transfer,
- Key which triggers printing or data transfer.

Factory setting

- Manual triggering with the ENTER key.
- The content of the display is transferred or printed.

3.14 Enter values with barcode reader

If you have connected an explosion-protected barcode reader to the ID7sx-Base weighing terminal, you can make all required entries, such as identifications or target specifications, easily with the barcode reader.

3.14.1 Read in any desired entries with the barcode reader

Example Read in identification Code A

1. Press CODE A key; the ID7sx-Base expects the entry of Code A.
2. Enter identification Code A with the barcode reader.
3. Confirm barcode entry with ENTER.

3.14.2 Read in a frequently used entry directly with the barcode reader

If your working procedure repeatedly requires the same entry, you can configure the barcode reader in the master mode (see section 4.5.2) so that no additional keys need to be pressed on the ID7sx-Base terminal for barcode entry.

Example Barcodes are automatically read in as Code A

If the working procedure requires the entry of Code A:

→ Enter identification Code A with barcode reader.

The read-in information is automatically processed by ID7sx-Base as Code A.

3.15 Working with a second display

The ID7sx weighing terminal can be connected to another METTLER TOLEDO weighing terminal for use as a second display. Conversely, another METTLER TOLEDO weighing terminal can be connected to the ID7sx weighing terminal for use as a second display. Both terminals must support the AUTO-DIR or TOLEDO CONTINUOUS protocols for this.

3.15.1 ID7sx used as a second display of another ID7sx

- An Active CL/IDNet module must be installed in the ID7sx weighing terminal used as the second display.
- Connection in accordance with terminal diagram 22006478, Sheet 3, see PSU guide for installers 22006472, Index C or greater.
- The AUTO-DIR operating mode must be set for the COM port used in the ID7sx serving as the weighing terminal. No special settings are required in the second display device.
- With ID7sx as a second display, the weight value fills the entire display (BIG WEIGHT® display ON).

3.15.2 ID7sx used as a second display on a weighing terminal in the safe area

- COM1 of the ID7sx weighing terminal must be lead to the safe area via a slotcard interface in the PSU. See terminal diagram 22006478, Sheet 2, in PSU guide for installers 22006472.
- The weighing terminal in the safe area must be connected to the CL output of the PSU power supply via one of its COM ports. Ensure that the CL interface configured as active in the weighing terminal is configured as passive in the PSU.
- IDNET must be set as the operating mode of COM1 at the ID7sx in mastermode. The proper baud rate is selected automatically here.
- The operating mode AUTO-DIR or TOLEDO CONTINUOUS with checksum must be set in the weighing terminal in the safe area for the COM port used.
- With TOLEDO CONTINUOUS with checksum, the following communication parameters must be set explicitly: 9600 baud, 7 data bits, even parity, 1 stop bit. With AUTO-DIR, the correct communication parameters are set automatically.
- With ID7-... as a second display, the weight value fills the entire display (BIG WEIGHT® display ON).

3.15.3 Weighing terminal in the safe area as a second display of an ID7sx

- COM1, COM2 or COM3 of the ID7sx weighing terminal must be lead to the safe area via a slotcard interface in the PSU. See terminal diagram 22006478, Sheet 2, in guide for installers 22006472.
- The weighing terminal in the safe area must be connected to the CL output of the PSU power supply via its ID-Net interface. Ensure that the CL interface is configured as passive in the PSU here.
- AUTO-DIR must be selected as the operating mode of the selected port at the ID7sx. No special settings are required at the second display in the safe area.

3.15.4 Operation possibilities on second display

The following functions are also possible on the second display:

- Setting to zero
- Taring

3.16 Recall data from memory module

With the Memory-ID7sx module you can fulfill your recording obligations in certified operation without having to archive paper.

Memory-ID7sx automatically assigns each weighing with consecutive data record number which also appears on the print-out, saves the net and tare value, the date and time.

Memory-ID7sx operates according to the principle of a ring memory: When the capacity limit of approx. 700000 data records is reached, the oldest data record is deleted and overwritten with data from the latest weighing.

By entering suitable search criteria you can quickly access the data of a very specific weighing.

Condition

Memory-ID7sx installed and COM4 configured as Memory, see Section 4.5.

3.16.1 Initiate

→ Press INFO, ALIBI key sequence.

The function keys change to the following assignment:

FIND	>>...	<	>	Num	END
Enter search criteria	Search for next matching data record starting with oldest	Display data record of weighing carried out directly beforehand	Display directly following weighing	Search for data record with known data record number	Exit Info Alibi and return to normal mode

3.16.2 Fast search with entry of data record number

1. Press ->Num key.
2. Enter number of data record to be searched for and confirm with ENTER.
Memory-ID7sx now searches for the desired data record.

Notes

- The search may take up to 10 seconds.
- If no data record with the entered number is found, the message NO MATCHING DATA RECORD appears.

3.16.3 Search with other search criteria

→ Press FIND key.

The function keys are given the following assignment:

DATE	TIME	NET	TARE		START
Enter date as search criterion	Enter time as search criterion	Enter net value as search criterion	Enter tare value as search criterion		Start search with entered search criteria

All offered search criteria can be combined with each other.
The entered search criteria are shown in the display in clear text.
This enables you to search for a find a specific weighing.

Enter date

→ Press DATE key and enter complete date in DD.MM.YY form.

Enter time

→ Press TIME key and enter desired time in one of following formats.

Format HH all weighings between HH.00.00 and HH.59.59 are found

Format HH.MM all weighings between HH.MM.00 and HH.MM.59 are found

Format HH.MM.SS only the weighing at the time HH.MM.SS is found

Enter net/tare value

1. Press NET or TARE key.
2. Enter weight value and confirm with ENTER.
The function key assignment changes back again for selection of the search criteria.

Note

With the FUNCTION CHANGE key you can select the weight unit for entering the weight values.

Start search

→ Press START key.

Memory-ID7sx searches for the oldest data record which meets the entered search criteria.

Notes

- The search may take up to 10 seconds.
- If no data record with the entered values is found, the message NO MATCHING DATE RECORD appears.
- If no search criterion has been entered, the oldest data record is displayed.

3.16.4 Display data records

The data records found are shown in the display:

Example DATE: 02.04.98 TIME: 09.25.51
 NUM: 000987
 NET: 25.000 KG
 TARE: 100.346 KG PT

Scroll With the keys >>..., < and > you can scroll within the data records found.

Notes

- If during scrolling with the >>... key all entries of the Memory-ID7sx have been searched, the message END OF FILE appears.
- If during scrolling with the keys < and > the file end is reached, the display begins again at the first or last data record.

4 Settings in the master mode

4.1 Overview of the master mode

In the master mode you adapt the ID7sx-Base weighing terminal to meet your needs. Depending on the configuration, the master mode is divided into 4 or 5 master mode blocks, which are in turn divided into further blocks.

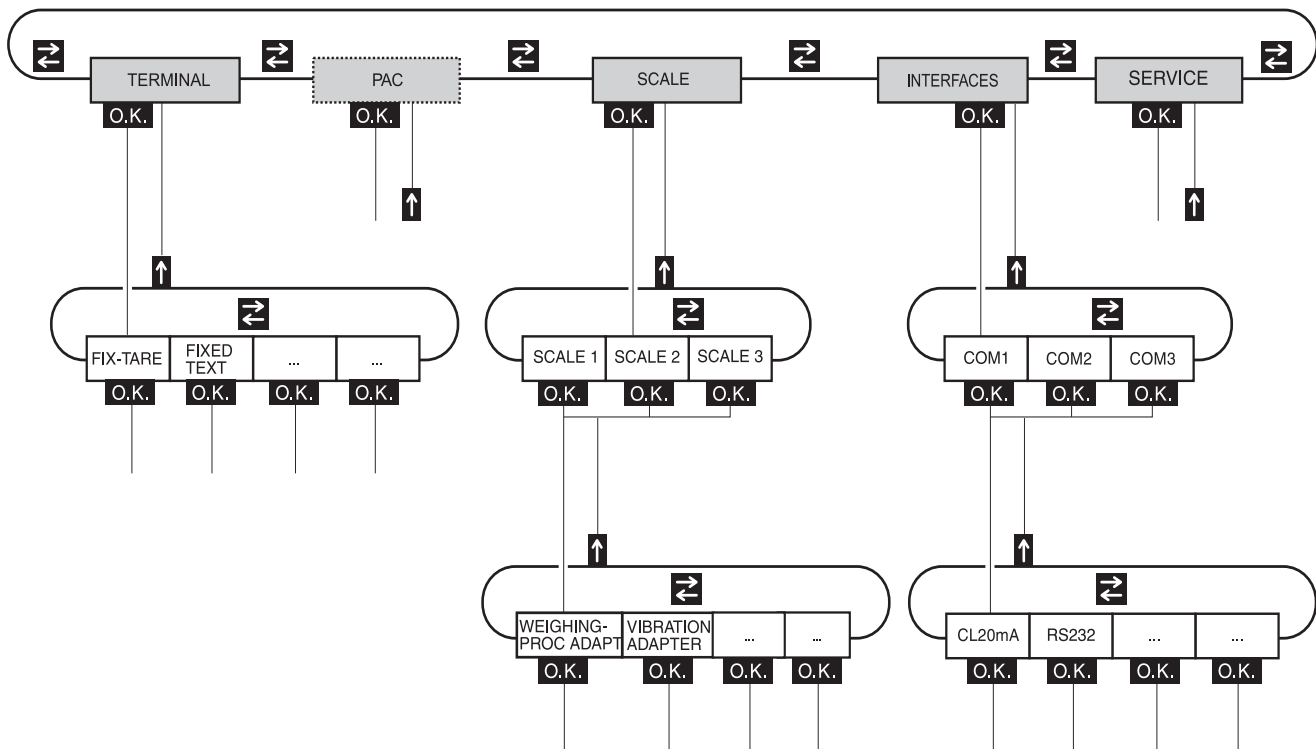

TERMINAL For system settings, such as entering the date and time or loading permanent texts, see section 4.3.2.

PAC To set application-specific parameters.
This block does not appear with ID7sx-Base.

SCALE To select one of the connected weighing platforms. For each selected weighing platform the parameters are then set which concern the weight value, e. g. stability detector, unit, etc., see section 4.4.

INTERFACES To select an interface. The communication parameters are then set for each interface, see section 4.5.

SERVICE For configuring the weighing platform(s). On IDNet weighing platforms only for METTLER TOLEDO service technicians.

4.2 Operating the master mode

4.2.1 Enter the master mode

1. Press MODE key.
If the current function key assignment does not contain MODE, change to the assignment with MODE by repeatedly pressing the FUNCTION CHANGE key.
2. Enter personal code if configured.
The display shows the first master mode block TERMINAL.

4.2.2 Assignment of function keys in the master mode

Depending on the number of parameters offered in the display, in the master mode the function keys are assigned as follows:

1 parameter

←	→		↑	END	OK
Change to previous block within a level	Change to next block within a level		Exit level and return to higher-level block	Exit the master mode and return to normal mode	Recall lower-level block or confirm selection

Several parameters

←→	<	>	F▶	ADD	↑
Select parameter	Adjust parameter		Select function of function key F5: STD, ADD, INS etc.	STD ADD INS EDIT DEL PRINT SAVE	Accept settings and return to upper-level block

The printout can be edited with function key F5:

STD	Select standard setting, lights up if factory setting selected.
ADD	Adds a new entry at the end of the printout.
INS	Inserts a new entry in front of the displayed entry.
EDIT	Changes into the EDIT mode for the displayed entry to edit the entry.
DEL	Deletes the displayed entry.
PRINT	Creates a key printout.
SAVE	Confirm changes and return to upper-level block

4.2.3 Orientation in the master mode

If only one parameter appears, the display shows the last steps in the path of the current master mode block for improved orientation.

Example The upper 4 lines of the display show the following path for selecting the COMMUNICATION interface settings:

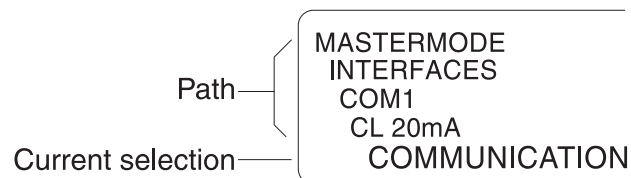

4.2.4 Entries in the master mode

The following basic rules apply to entries made in the master mode:

- Confirm (alpha)numeric entries with ENTER.
- Alphanumeric entries with the ID7sx-Base: see section 3.11.
- To accept the displayed value: Press ENTER key.

4.2.5 Emergency entrance into the master mode

If a personal code has been assigned for entering the master mode and you have forgotten your code, you can still enter the master mode:

→ Enter the character sequence C, L, E, A, R as your personal code.

4.3 TERMINAL master mode block

4.3.1 Overview of the TERMINAL master mode block

In the TERMINAL master mode block you enter the following system settings:

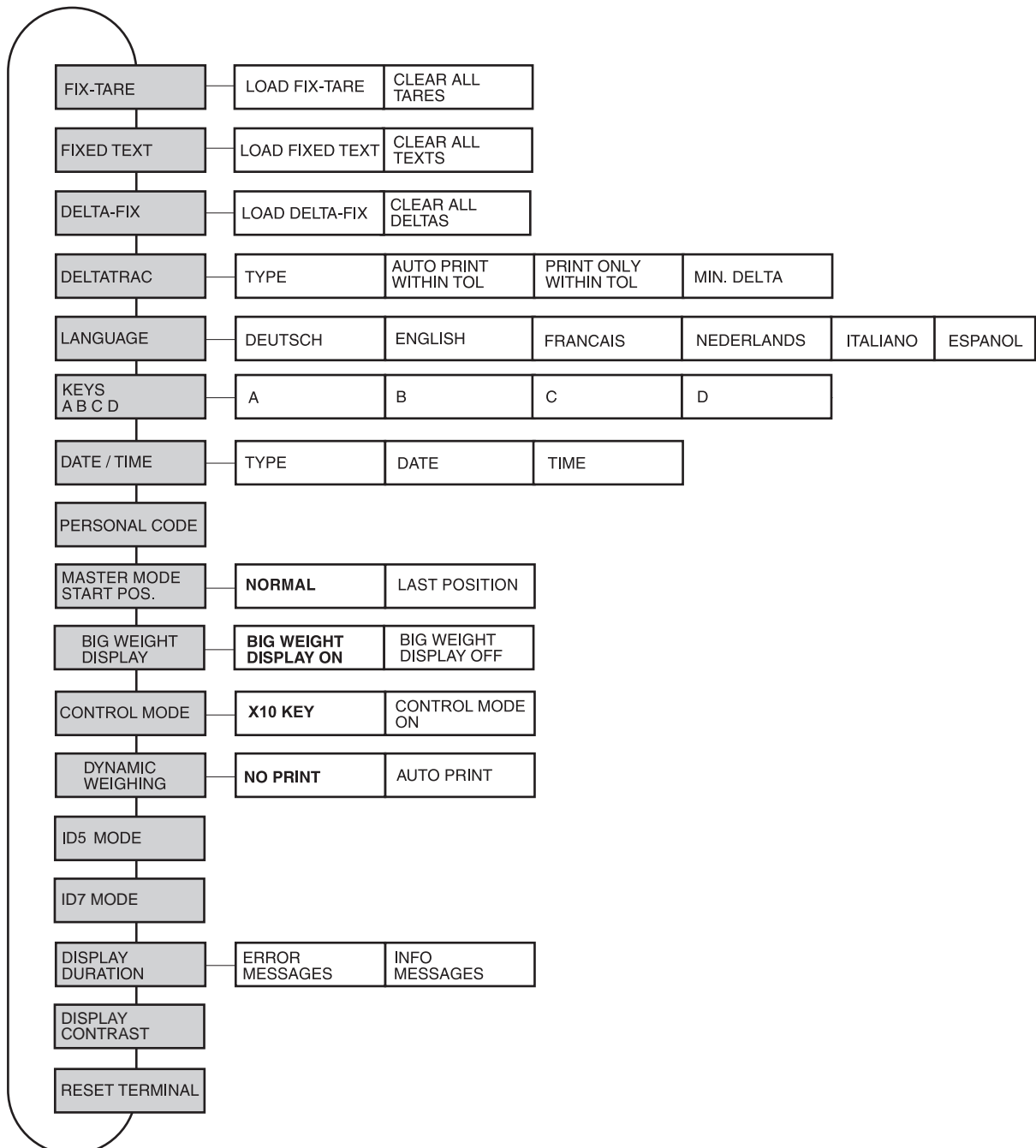

- Legend**
- Blocks highlighted in **grey** are described in detail in the following.
 - Factory settings are printed in **bold print**.

4.3.2 Settings in the TERMINAL master mode block

FIX-TARE	Save tare values protected against power failure to tare memories
LOAD FIX-TARE	<ol style="list-style-type: none"> 1. Enter memory number of FIX-TARE NO.: 1 ... 999. 2. Enter tare weight for the selected memory in the displayed unit. 3. To load additional fixed tare values, repeat the first two steps. 4. End entry: Confirm FIX-TARE NO. without entry with ENTER.
CLEAR ALL TARES	Delete all tare memories.

FIXED TEXT	Save texts protected against power failure to text memories
	These texts can be assigned, for example as identifications, or also output during printing.
LOAD FIXED TEXT	<ol style="list-style-type: none"> 1. Enter memory number of FIXED TEXT NO.: 1 ... 999. 2. Enter text for the selected memory: max. of 20 characters. 3. To load additional fixed texts, repeat the first two steps. 4. End entry: Confirm FIXED TEXT NO. without entry with ENTER.
CLEAR ALL TEXTS	Delete all text memories.
Comment	Fixed Text No. 20 is displayed during switch-on and with a restart.

DELTA-FIX	Save target weight/tolerance combinations in DeltaTrac memory
LOAD DELTA-FIX	<ol style="list-style-type: none"> 1. Enter memory number of DELTA-FIX No.: 1 ... 999. 2. Enter target weight DELTA in the displayed unit. 3. Enter tolerance TOL in %. 4. To enter additional Delta-Fix, repeat the first three steps. 5. End entry: Confirm memory number without entry with ENTER.
CLEAR ALL DELTA	Delete all DeltaTrac memories.
Comment	With the FUNCTION CHANGE key you can select the weight unit for entering the DeltaTrac target and tolerance values.

DELTATRAC	Set DeltaTrac application
TYPE	Select DeltaTrac application
FILLING	Weigh in target weight within a tolerance range (factory setting).
CLASSIFYING	Evaluate the test samples as good, too light or too heavy based on the target weight and tolerance.
CHECKWEIGHING	Determine difference between target and actual weight.
AUTO PRINT WITHIN TOL	Automatic printout when actual weight lies within the specified tolerance
PRINT ONLY WITHIN TOL	Printout only when actual value lies within the specified tolerance
MIN. DELTA	Specify minimum target weight: 40 d

LANGUAGE	Select dialog language
	Possible settings: German, English, French, Dutch, Italian, Spanish

KEYS A B C D	Name identification keys CODE A ... CODE D
A	Identification data CODE A Set name and number of characters
B	Identification data CODE B Set name and number of characters
C	Identification data CODE C Set name and number of characters
D	Identification data CODE D Set name and number of characters
Note	Max. 30 characters possible, factory setting: 20 characters

DATE / TIME	Enter date and time
TYPE	
EUROPE	Select European notation: Day.Month.Year / (24) Hours.Minutes.Seconds.
US	Select American notation: Month.Day.Year / (12) Hours.Minutes.Seconds. AM/PM,
DATE	Enter date according to the type selected
TIME	Enter time according to the type selected
Comments	<ul style="list-style-type: none"> • Enter single-place numbers with a preceding zero. • Change over between AM and PM: Press FUNCTION CHANGE key. • Date and time can be printed out. • The clock continues to run after the terminal is switched off.

PERSONAL CODE	Load or delete code for entering the master mode
CODE	Enter code with a maximum of 8 alphanumeric characters.
Comment	If no code is entered, access to the master mode is unrestricted.

MASTER MODE START POS.	Select start position for entering the master mode
NORMAL	Selection of the master mode blocks always begins with the TERMINAL block (factory setting).
LAST POSITION	When entering the master mode, the last block edited is displayed immediately.

BIG WEIGHT DISPLAY	Switch full-display indication of the weight on or off
	Factory setting: BIG WEIGHT DISPLAY ON

CONTROL MODE	Adjust control mode
X10 KEY	Activation of control mode with X10 key (factory setting).
CONTROL MODE ON	This setting is only possible with non-certified scales. The weighing terminal always operates with the higher resolution.

DYNAMIC WEIGHING	Set printing during dynamic weighing
NO PRINT	Results during dynamic weighing are not automatically printed out (factory setting).
AUTO PRINT	Each result during dynamic weighing is automatically printed. Dynamic weights are marked with "Result:" on the printout.

ID5 MODE	Deactivating or activating downward compatibility with ID5								
	<p>If ID5 MODE ON is selected, the ID7sx-Base is operated with downward compatibility to the ID5.</p> <p>Affected settings</p> <table> <tr> <td>Text length of identification data</td> <td>18 characters</td> </tr> <tr> <td>Text length for keys CODE A ... D</td> <td>max. 18 characters</td> </tr> <tr> <td>Date/time</td> <td>dd/mm/yy, hh-mm-ss</td> </tr> <tr> <td>Barcode print command</td> <td>P\$#1EAN13 P\$#2Code 39 P\$#3EAN13</td> </tr> </table> <p>Factory setting: ID5 MODE OFF</p>	Text length of identification data	18 characters	Text length for keys CODE A ... D	max. 18 characters	Date/time	dd/mm/yy, hh-mm-ss	Barcode print command	P\$#1EAN13 P\$#2Code 39 P\$#3EAN13
Text length of identification data	18 characters								
Text length for keys CODE A ... D	max. 18 characters								
Date/time	dd/mm/yy, hh-mm-ss								
Barcode print command	P\$#1EAN13 P\$#2Code 39 P\$#3EAN13								

ID7 MODE	Deactivating or activating compatibility with ID7
	<p>The ID7sx-Base is as compatible with the ID7-... as possible. If ID7-MODE ON is selected, all known differences are made irrelevant.</p> <p>Factory setting: ID7 MODE OFF</p>

DISPLAY DURATION	Set display duration for messages
ERROR MESSAGES	Set display duration for error messages; factory setting: 1 second
INFO MESSAGES	Set display duration for informational messages; factory setting: 2 seconds

DISPLAY CONTRAST	Set contrast of the LCD display
	Change the contrast in increments with the + and – function keys.

RESET TERMINAL	Reset all terminal functions to the factory setting
	DELTATRAC Filling MASTER MODE START POS. Normal BIG WEIGHT DISPLAY On DYNAMIC WEIGHING No printout CONTROL MODE X 10 key ID5 MODE Off ID7 MODE Off
Comment	The memories are not affected by this.

4.4 SCALE master mode block

In the first block the weighing platform is selected: SCALE 1 ... SCALE 3.
The other setting possibilities are the same for all connected weighing platforms.

4.4.1 Overview of the SCALE master mode block

In the SCALE master mode block the following settings for the weight can be carried out:

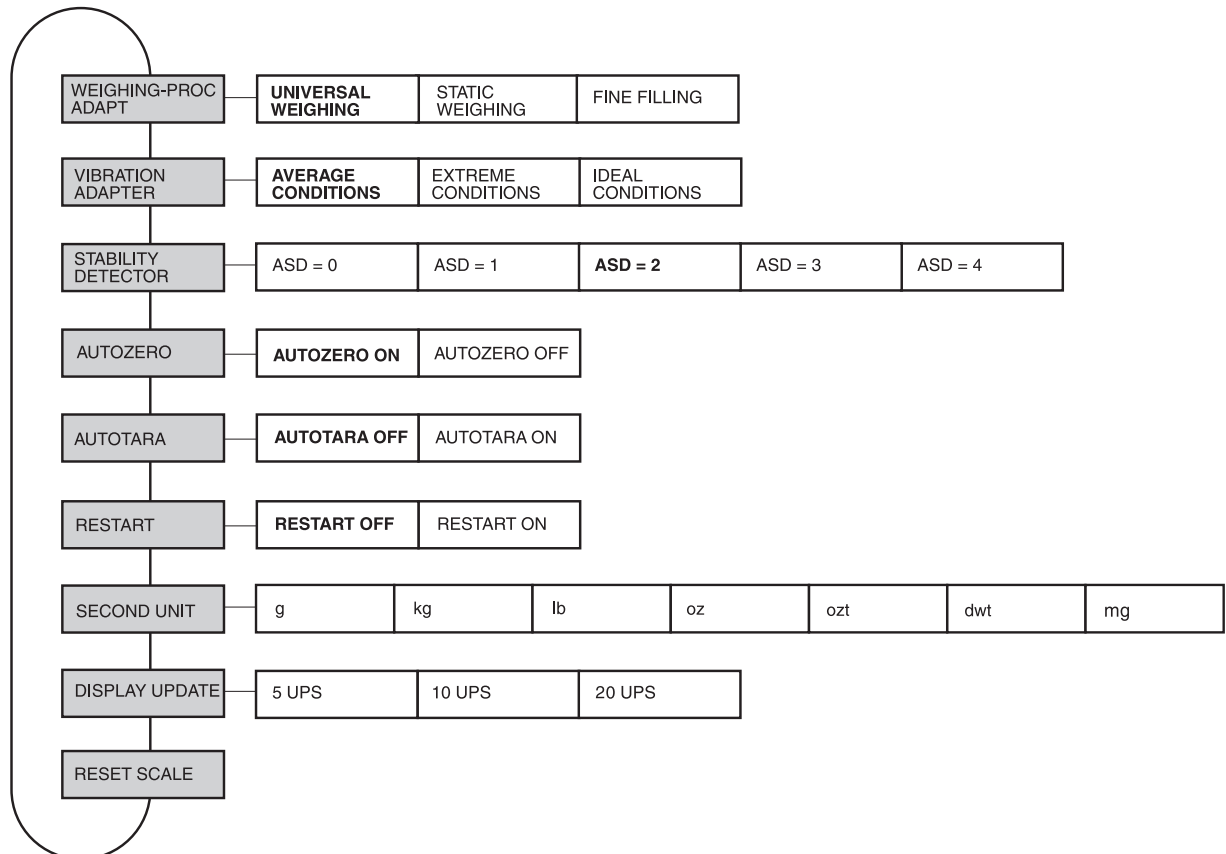

- Legend**
- Blocks highlighted in **grey** are described in detail in the following.
 - Factory settings are printed in **bold print**.

4.4.2 Settings in the SCALE master mode block

WEIGHING-PROC ADAPT	Adapt weighing platform to weighing sample
UNIVERSAL WEIGHING	For solid bodies, coarse filling or checkweighing (factory setting).
STATIC WEIGHING	For solid bodies and weighing under extreme conditions, e. g. strong vibrations or weighing animals.
FINE FILLING	For liquid or powdered weighing samples.

VIBRATION ADAPTER	Adapt weighing platform to the vibration influences of the environment
AVERAGE CONDITIONS	Factory setting.
EXTREME CONDITIONS	The weighing platform operates more slowly, however is less sensitive, e. g. suitable with building vibrations and vibrations at the weighing location.
IDEAL CONDITIONS	The weighing platform operates very quickly, however is very sensitive, e. g. suitable with very calm and stable weighing location.

STABILITY DETECTOR	Adapt automatic stability detector
	<p>Possible settings:</p> <p>ASD = 0 Stability detector switched off (only possible with non-certified weighing platforms)</p> <p>ASD = 1 fast display good reproducibility</p> <p>ASD = 2 ▲ ▼ (factory setting)</p> <p>ASD = 3 ▲ ▼</p> <p>ASD = 4 slow display very good reproducibility</p>

AUTOZERO	Switch automatic zero-point correction on or off
	The automatic zero-point correction corrects the weight of minor dirt with the weighing platform unloaded. Factory setting: AUTOZERO ON
Comment	On certified weighing platforms the zero-point correction is always switched on.

AUTOTARA	Switch automatic taring on or off
	Factory setting: AUTOTARA OFF

RESTART	Switch restart function on or off
	When RESTART ON is set, the zero point and tare value remain stored after the power supply is interrupted. When the weighing platform is switched on again, the terminal shows the current weight. Factory setting: RESTART OFF

SECOND UNIT	Select second weight unit																								
	Possible units: g, kg, lb, oz, ozt, dwt <table border="1"> <thead> <tr> <th>Unit</th> <th>Abbreviation</th> <th>Conversion to g</th> </tr> </thead> <tbody> <tr> <td>Kilogram</td> <td>kg</td> <td>= 1000 g</td> </tr> <tr> <td>Pound</td> <td>lb</td> <td>≈ 453.59237 g</td> </tr> <tr> <td>Ounce</td> <td>oz</td> <td>≈ 28.349523125 g</td> </tr> <tr> <td>Troy Ounce</td> <td>ozt</td> <td>≈ 31.1034768 g</td> </tr> <tr> <td>Pennyweight</td> <td>dwt</td> <td>≈ 1.555173843 g</td> </tr> <tr> <td>Gram</td> <td>g</td> <td>= 1 g</td> </tr> <tr> <td>Milligram</td> <td>mg</td> <td>= 0.001 g</td> </tr> </tbody> </table>	Unit	Abbreviation	Conversion to g	Kilogram	kg	= 1000 g	Pound	lb	≈ 453.59237 g	Ounce	oz	≈ 28.349523125 g	Troy Ounce	ozt	≈ 31.1034768 g	Pennyweight	dwt	≈ 1.555173843 g	Gram	g	= 1 g	Milligram	mg	= 0.001 g
Unit	Abbreviation	Conversion to g																							
Kilogram	kg	= 1000 g																							
Pound	lb	≈ 453.59237 g																							
Ounce	oz	≈ 28.349523125 g																							
Troy Ounce	ozt	≈ 31.1034768 g																							
Pennyweight	dwt	≈ 1.555173843 g																							
Gram	g	= 1 g																							
Milligram	mg	= 0.001 g																							
Comment	On certified weighing platforms only the units permitted by certification appear.																								

DISPLAY UPDATE	Set display speed of the weight display
	Select number of updates per second (UPS).
Comments	The possible settings are dependent on the connected weighing platform.

RESET SCALE	Reset weighing platform to factory setting
	WEIGHING-PROC ADAPT universal weighing VIBRATION ADAPTER average conditions STABILITY DETECTOR ASD = 2 AUTOZERO on AUTOTARA off RESTART off

4.5 INTERFACE master mode block

- Select interface connection** → Select the interface connection in the first block:
COM1 ... COM5.
- Select interface type** → Specify the interface type for the selected interface connection COM1 ... COM5.
- Possible interface types**
- NOT ASSIGNED When the selected interface connection is not assigned.
 - CL20mA For COM1 ... COM3 only.
A CL20mA-ID7sx interface must be installed on the interface connection for this purpose. For other settings see 4.5.1.
 - RS232 for COM2 or COM3 only.
An RS232-ID7sx interface must be installed on the selected interface connection for this purpose. For other settings see 4.5.1.
 - GA46 For COM1 ... COM3 only.
For connection of the GA46/GA46-W printer via the PSU power supply unit in the safe area.
A CL20mA-ID7sx or RS232-ID7sx interface must be installed on the interface connection for this purpose.
The other setting possibilities are described in the operating and installation instructions GA46.
This selection no longer appears when a GA46 printer is already configured.
 - BARCODE For COM2 or COM3 only.
For connection of an explosion-protected barcode reader.
An RS232-ID7sx interface must be installed on the selected interface connection for this purpose. For other settings see 4.5.2.
 - MEMORY For COM4 only.
A Memory-ID7sx module must be installed for this purpose.
No further settings are required in the master mode.
This selection no longer appears when a Memory-ID7sx module is already configured.
 - 8 I/O For COM5 only.
An 8 I/O-ID7sx interface must be installed on the selected interface connection for this purpose. For other settings see 4.5.3.
 - PROFIBUS-DP For COM1 only.
A Profibus-DP-ID7sx module must be installed on COM1. For other settings, see 4.5.4.
 - IDNET For COM1 only.
In this setting, COM1 has the same functionality as an IDNet interface. This allows the ID7sx-Base to be connected to a weighing terminal in the safe area as a second display. For other settings, see 3.15.

4.5.1 Settings in the master mode blocks CL20mA and RS232

CL20mA, RS232	
COMMUNICATION	Set communication parameters (factory settings are shown in bold print). All parameters are shown on a display page and can be set there.
BITS PER CHARACTER	Possible settings: 7 bits , 8 bits
STOPBITS	Possible settings: 1 stop bit, 2 stop bits
PARITY	Possible settings: Even , Odd, No
BAUDRATE	Possible settings: 150, 300, 600, 1200, 2400 , 4800, 9600, 19200 baud
MODE	Set operating mode.
STANDARD SETTING	Set operating mode to factory setting: MMR dialog mode, no handshake, no auto transmission (no continuous transmission), transfer string: Standard, string framing: C _R L _F
DIALOG MODE	For dialog between ID7sx-Base weighing terminal and computer. For other settings see next section.
PRINT MODE	To print weighing data, e. g. on a form printer. For other settings see page 42.

Set dialog mode

DIALOG MODE	Set dialog between ID7sx-Base weighing terminal and computer
<p>MMR</p> <p>HANDSHAKE</p> <p>AUTOMATIC CONTINUOUS TRANSMISSION</p>	<p>For information on dialog mode with the MMR command set, see section 5.1.</p> <p>Possible settings:</p> <ul style="list-style-type: none"> • NO HANDSHAKE • CL HANDSHAKE – for additional information on the CL handshake, see page 41. • XON-XOFF PROTOCOL. <p>Possible settings:</p> <ul style="list-style-type: none"> • NO AUTO TRANSMISSION. • AUTO SIR – after each measuring cycle a stabilized or dynamic weight is transmitted. • AUTO SR – after each weight change which is greater than the set value, a motionless weight value and then a dynamic weight value are sent • AUTO DIR – weight values are transmitted as with AUTO SIR and additionally, the special characters in the display are transmitted for a second display. Fixed communications parameters: 9600 baud, 7 data bits, 2 stop bits, parity even • AUTO-XIR – expanded AUTO-DIR operating mode for adaptation to an ID7sx-Sys in the safe area.
<p>TRANSFER STRING</p> <p>STRING FRAMING</p>	<p>Possible settings:</p> <ul style="list-style-type: none"> • STANDARD – gross, net, tare • USER-DEFINED – enter numbers of the application blocks which are to be transmitted or printed out. <p>Possible settings:</p> <ul style="list-style-type: none"> • ---<CR><LF> (Factory setting) • <STX>---<ETX> • BLOCK CHECK CHAR • ---<CR>
<p>SICS</p> <p>STANDARD</p> <p>HANDSHAKE</p> <p>AUTOREPEAT</p>	<p>Dialog mode with Standard Interface Command Set (SICS), see section 5.3.</p> <p>Standard setting: no handshake, no auto transmission.</p> <p>Possible settings as MMR, see previous page.</p> <p>Possible settings as MMR, see previous page. AUTO-DIR not possible with SICS.</p>

DIALOG MODE	Set dialog between ID7sx-Base weighing terminal and computer
TOLEDO CONTINUOUS	For the continuous transmission of net and tare values to METTLER TOLEDO devices, e. g. to a second display. For a description, see section 5.2.
CHECKSUM ON	Checksum byte active, factory setting
CHECKSUM OFF	Checksum byte inactive, the transfer format is shortened by 1 character.
TOLEDO SHORT CONTINUOUS	For the continuous transmission of net values to METTLER TOLEDO devices, e. g. to a second display. For a description, see section 5.2.
CHECKSUM ON	Checksum byte active, factory setting
CHECKSUM OFF	Checksum byte inactive, the transfer format is shortened by 1 character.

CL handshake

With the CL handshake 3 types of interface control are possible:

Handshake in receiving direction, in transmitting direction and in both directions.

After switch-on and after each interruption, the ID7sx-Base attempts to establish the handshake in both directions.

CL handshake in receiving direction

This type of CL handshake is suitable for data transmission from the ID7sx-Base to the computer.

1. The ID7sx-Base transmits SYN after switch-on.
2. The computer transmits the character ACK after switch-on or after receiving SYN.
3. ID7sx-Base then sends the response to a command or to a key actuation after each ACK.

CL handshake in transmission direction

This type of CL handshake is suitable for data transmission from the computer to the ID7sx-Base.

1. The ID7sx-Base transmits SYN after switch-on.
2. The computer transmits the character SYN after switch-on or after receiving SYN.
3. ID7sx-Base acknowledges the receipt of SYN again with SYN and signals its readiness to receive with ACK.
4. Then the computer can transmit a command after each ACK.

CL handshake in both directions

1. The ID7sx-Base transmits SYN after switch-on.
2. The computer transmits the character SYN after switch-on or after receiving SYN.
3. ID7sx-Base acknowledges the receipt of SYN again with SYN and signals its readiness to receive with ACK.

4. The computer signals its readiness to receive with ACK.

5. During operation the ID7sx-Base receives data and transmits ACK when it is ready to receive data again.

The computer receives data and transmits ACK when it is ready to receive data again.

Set print mode

PRINT MODE	Configure printout on an external printer
HANDSHAKE	Possible settings: <ul style="list-style-type: none"> • NO HANDSHAKE • XON-XOFF PROTOCOL
LINE LENGTH	Enter number of characters per line. Possible settings: 1 ... 80 characters Factory setting: 40 characters
LINE FRAMING	Enter ASCII character for line framing. Possible settings: ASCII 0 ... 255 Factory setting: ASCII 013 010 (C _R L _F)
REPORT TYPE	Assignment of one of two possible printout formats to the configured printer. Possible settings: <ul style="list-style-type: none"> • REPORT TYPE A e.g. for barcode printer • REPORT TYPE A e.g. for A4 printer
CONFIGURATION PRINTOUTS TRANSFER KEY CODE A KEY ... CODE D KEY DYNAMIC KEY Pac keys	Configuration of the printouts assigned to the individual keys. For each offered key, the current configuration can be printed out with the key sequence CHANGE CONFIGURATION, F▶ (possibly several times) and PRINT. Configuration options: <ul style="list-style-type: none"> • DELETE ALL All blocks of the data string are deleted • DEFAULT SETTING Key-specific, if existent • CHANGE CONFIGURATION See next section • PAPER FEED Adjustment range: 0 ... 9 lines • REPORT ON/OFF Switch key printout on/off
AUTOMATIC PRINTOUT	Switch automatic printout for transfer key on/off. When AUTO PRINTOUT ON is selected, a printout for the transfer key is automatically created for each weight change > x digits. Possible settings: 1 ... 255 digits (factory setting: 30 digits)

Change configuration

Display page The setting of the parameters of an entry appears in a clear layout on a display page (example):

TRANSFER KEY	[EDIT]	(2/7)
TYPE: AB		STYLE: <input type="checkbox"/> <input checked="" type="checkbox"/> <input type="checkbox"/>
CRLF: YES	FILL: NO	PAD: 01
DATA:		011-013









First display line Information for orientation in an entry

- Key name
- Mode: EDIT, INS or ADD
- Number of the display entry and total number of entries for the current printout.



TYPE parameter Selection possibilities:

- AB Output content of an application block with or without designation
- TEXT Print out any desired text
- CHRn Insert n of any desired ASCII characters in the line, e.g. for tables; selection of character via DATA parameter
- LINE Blank line or separator line with any desired alphanumeric characters
- DB Accesses a database field. When a field is printed out, all entries of the field are listed.
- The option DB is only available when the software application supports access to a database.
- The offered database fields are application-specific.



STYLE parameter STYLE determines in which format the designation and content of the application block are printed; adjustment possibilities:

TYPE	STYLE
AB DB	 Designation and content in grouped style
	 Designation and content in two lines, grouped style
	 Designation and content separated with extra blank spaces
	 Content alone, left-justified
	 Content alone, centred
	 Content alone, right-justified
TEXT	 Left-justified
	 Centred
	 Right-justified

CRLF parameter Force line feed; the CRLF parameter is only available for:

-  Text, left-justified
-  Content alone, left-justified
-  Designation and content separated with extra blank spaces
- Type CHRn



FILL parameter Show content with leading blank spaces up to maximum available length; the FILL parameter is only available for:

-  Designation and content separated with extra blank spaces
-  Content alone, left-justified
-  Content alone, centred

PAD parameter Show designation and content separated with x blank spaces

Possible settings: 0 ... 63 extra blank spaces.

The PAD parameter is only available for:

-  Designation and content separated with extra blank spaces
-  Content alone, left-justified

DATA/FIELD parameter Depending on the TYPE selected, DATA or FIELD is available.

TYPE	DATA/ FIELD	ENTRY
LINE	DATA	1 alphanumeric character Entry also possible as ASCII code, see below
AB	DATA	Number of application blocks to be output: xxx The application block can be further specified with the following keys: AB_EXT: _ For selecting read-only memories: xxx_yyy SUB-BLK: . For selecting a sub-block: xxx.z or xxx_yyy.z RANGE: - For entering a range: xxx-xxx or xxx_yyy-yyy
CHRn	DATA	up to 240 alphanumeric characters Entry also possible as ASCII code, see below
TEXT	DATA	Alphanumeric characters
DB	FIELD	Select database field

**Entry of
DATA parameter**

To enter data or select database fields, the EDIT mode must be active.

1. Press **F▶** key, repeat if necessary until the assignment of the F5 key changes to EDIT.
2. Press the EDIT key; an input mask appears.
3. Enter data in the format and with the keys offered.
4. Complete entry with ENTER.

Enter ASCII code for LINE and CHRn parameters and TEXT

1. Open the entry mask with the EDIT key.
2. Press the +/- key and enter the ASCII code numerically.
3. Complete the numeric entry with the +/- key.
4. Complete entry with ENTER.

**SETPOINT MODE ON –
defining set points**

After SETPOINT MODE ON is selected, the following input mask appears (Example):

SP1:	F↑	AO12	W1	1.2345 KG
SP2:	F↓	AO13	W2	0.5678 KG
SP3:	D↑	AO12	ALL	
SP4:	D↓	AO11	ALL	

4 parameters can be set for each set point:

a) Type of set point

- F↑ fixed set point, ascending
- F↓ fixed set point, descending
- D↑ dynamic set point, ascending
- D↓ dynamic set point, descending

Fixed set point Set point value is specified in the master mode and cannot be changed in the weighing mode.

Dynamic set point Set point value is specified in the weighing mode, see Section 3.6.

Ascending Digital output is set when the value of the application block concerned is greater than or equal to the set point value.

Decending Digital output is set when the value of the application block concerned is less than or equal to the set point value.

b) Application block

Weight value to which the set point refers. All application blocks with a valid weight unit are possible.

Factory setting: Application block 012, net weight

c) Scale

W1 ... W3 or ALL for all scales

d) Set point value

With dynamic set points the weight value is entered in the normal mode, see Section 3.6.

4.5.4 Configuring Profibus-DP-ID7

PROFIBUS-DP	Configuring Profibus-DP-ID7
NODE ADDRESS	Select desired node address in range 001 to 126. Factory setting: 126
OPERATING MODE	Set type and word length of user data parameter VALUE.
16-BIT-INTEGER / 2 WORDS	Consistent over valid module pair in GSD file 2 words 16-BIT-INTEGER 2(+2)W AI 16-BIT-INTEGER 2(+2)W AO
16-BIT-INTEGER / 4 WORDS	2 words 16-BIT-INTEGER 2(+2)W AI (use 2x) 16-BIT-INTEGER 2(+2)W AO (use 2x)
32-BIT-FLOATING- POINT	4 words 32-BIT-FLOATING-POINT 4W AI 32-BIT-FLOATING-POINT 4W AO
SETPOINT MODE	Set type and use of setpoint.
UNIVERSAL	Each setpoint can be set and read independently of others.
CHECKWEIGHING	As soon as setpoints 1 and 2 are set, DeltaTrac CHECKWEIGHING will be activated with SP1 = setpoint and SP2 = tolerance (in %, in 16-bit integer mode with 2 decimal places). In read table current state BELOW (SP1), GOOD (SP2) or ABOVE (SP3) can be read off.
FILLING	As soon as setpoints 1 and 2 are set, DeltaTrac CHECKWEIGHING will be activated with SP1 = setpoint and SP2 = tolerance (in %, in 16-bit integer mode with 2 decimal places). In addition, SP3 and SP4 can also be loaded as any desired setpoints. In read table current state GOOD (SP1), ABOVE (SP2), SP3 REACHED (SP3) or SP4 REACHED (SP4) can be read off.
INPUT MODE	Set request for identification data in Input mode. After setting the user data command INPUT MODE in the write table, the selected request for input is automatically carried out and the entries are saved in the application blocks 094 to 097. The user data response INPUT MODE RUNNING remains set while the input mode is active.
A	Code A is requested.
A+B	Code B and Code A are always requested.
A+B+C	Code C, Code B and Code A are always requested.
A+B+C+D	Code D, Code C, Code B and Code A are always requested.

PROFIBUS-DP	Configuring Profibus-DP-ID7																														
<p>EXP. AB AREA</p>	<p>Input of up to three expanded application blocks for constants which can be accessed when writing applications blocks.</p> <p>Example</p> <p>Input enables access to</p> <p>021 application blocks 021_001 to 021_999</p> <p>046 application blocks 046_001 to 046_999</p> <p>071 application blocks 071_001 to 071_999</p>																														
<p>TEST MODE</p>	<p>Activation of the information display. In line 3 and 4 write and read tables are displayed as follows:</p> <div style="text-align: center; border: 1px solid black; padding: 10px; margin: 10px auto; width: fit-content;"> <table style="border-collapse: collapse; width: 100%;"> <tr> <td style="width: 15%;"></td> <td style="width: 15%; text-align: center;">3</td> <td style="width: 15%; text-align: center;">4</td> <td style="width: 15%;"></td> <td style="width: 15%; text-align: center;">5</td> <td style="width: 15%; text-align: center;">6</td> </tr> <tr> <td></td> <td style="border-right: 1px solid black; border-bottom: 1px solid black; padding: 2px;">TEST MODE</td> <td style="border-right: 1px solid black; border-bottom: 1px solid black; padding: 2px;">Id</td> <td style="border-right: 1px solid black; border-bottom: 1px solid black; padding: 2px;">Val</td> <td style="border-right: 1px solid black; border-bottom: 1px solid black; padding: 2px;">5432109876543210</td> <td style="border-bottom: 1px solid black; padding: 2px;">0.999 kg</td> </tr> <tr> <td style="text-align: right; padding-right: 5px;">2</td> <td style="border-right: 1px solid black; padding: 2px;">00</td> <td style="border-right: 1px solid black; padding: 2px;">0000</td> <td style="border-right: 1px solid black; padding: 2px;">00000000</td> <td style="border-right: 1px solid black; padding: 2px;">10000000</td> <td style="padding: 2px;">00 00</td> </tr> <tr> <td style="text-align: right; padding-right: 5px;">1</td> <td style="border-right: 1px solid black; padding: 2px;">00</td> <td style="border-right: 1px solid black; padding: 2px;">03E7</td> <td style="border-right: 1px solid black; padding: 2px;">0100000000000000</td> <td style="border-right: 1px solid black; padding: 2px;"></td> <td style="padding: 2px;">08 00</td> </tr> <tr> <td></td> <td colspan="5" style="border-top: 1px solid black; border-bottom: 1px solid black; text-align: center; padding: 2px;">CANCEL</td> </tr> </table> </div> <p>1 Read table</p> <p>2 Write table</p> <p>3 Operating mode (internal)</p> <p>4 Value (hexadecimal)</p> <p>5 Command/response bits</p> <p>6 Inputs/outputs (hexadecimal)</p>		3	4		5	6		TEST MODE	Id	Val	5432109876543210	0.999 kg	2	00	0000	00000000	10000000	00 00	1	00	03E7	0100000000000000		08 00		CANCEL				
	3	4		5	6																										
	TEST MODE	Id	Val	5432109876543210	0.999 kg																										
2	00	0000	00000000	10000000	00 00																										
1	00	03E7	0100000000000000		08 00																										
	CANCEL																														

Note

Once the Profibus settings are complete, the Profibus DP-ID7sx module must be de-energised. Only then do the new settings become active.

5 Interface description

To exchange data with a computer, the ID7sx-Base weighing terminal is equipped with an RS232 or CL20mA interface via the PSU power supply unit. Both interfaces can be adjusted individually, see section 4.5.

To operate the serial interfaces in the **dialog mode**, one of the following METTLER TOLEDO command sets must be selected in the master mode:

- MMR command set, see section 5.1.
- METTLER TOLEDO Continuous mode, see section 5.2.
- METTLER TOLEDO SICS command set, see section 5.3.

5.1 MMR command set

5.1.1 Syntax and formats of communication

Command format when transmitting weight formats

Identification	_	Weight value	_	Unit	Framing
Char. sequence for specification of command (1 ... 4 char.)		1 ... 8 digits, number of digits variable		1 ... 3 char., number of characters variable	Definable in master mode, factory setting: C _R L _F

Response format when transmitting weight formats

Identification	_	Weight value	_	Unit	Framing
Char. sequence for specification of response (2 ... 3 char.)		10 digits, right-justified, filled out with blank spaces		3 char., left-justified, filled out with blank spaces	definable in master mode, factory setting: C _R L _F

Example

Command Tare specification

T _ 1 3 . 2 9 5 _ k g

Response Tare specification

T B H _ _ _ _ _ 1 3 . 2 9 5 _ k g _ _

Data formats

- The following symbols are used in the following command description:

Weight value 10 characters with sign and decimal point, right-justified (with preceding blank spaces)

Unit 3 characters, left-justified (with following blank spaces)

Text_n maximum of n characters, left-justified

- The string framing is mandatory, however it is **not** contained in the following command description!
- Enter commands as ASCII characters. The following ASCII characters are available: 20 hex/32 deci ... 7F hex/127 deci, see section 9.1.

5.1.2 Command overview

Command	Meaning	Page
RO / R1	Switch keypad on/off	53
Z	Set weight display to zero after weighing platform stabilization	53
U_...	Change over terminal to a different weight unit	53
T	Tare	54
T_...	Specify tare weight	54
DY_...	Specify DeltaTrac target value	55
S	Transmit in case of weighing platform stabilization	55
SI	Transmit independent of weighing platform stabilization	55
SIR	Transmit repeatedly independent of weighing platform stabilization	55
SR	Transmit stabilized weight values repeatedly depending on a weight change	55
SR_...	Transmit repeatedly depending on weighing platform stabilization with specification of an excursion value	55
SX	Transmit data record after weighing platform stabilization	56
SXI	Transmit data record independent of weighing platform stabilization	56
SXIR	Transmit data record repeatedly independent of weighing platform stabilization	56
ARNo.	Read information of application block	57
AWNo_...	Write to application block	57
D_...	Write to display	57
P_...	Print alphanumeric characters or barcodes on the GA46	58,58
DS	Trigger acoustic signal	58
ID	Interrogate terminal identification	58
W_...	Actuating digital outputs	59

5.1.3 Command description

Switch keypad on or off

Command	<input type="text" value="R_0"/> Switch on keypad <input type="text" value="R_1"/> Switch off keypad
Response	<input type="text" value="R_B"/> Keypad switched on or off
Comments	<ul style="list-style-type: none"> • Factory setting: Keypad switched on. • When the keypad is switched off, the terminal cannot be operated manually.

Set zero

Command	<input type="text" value="Z"/> Set gross weight display to zero after weighing platform stabilization, effect as when ZERO-SET key is pressed.
Response	<input type="text" value="Z_B"/> Weighing platform set to zero <input type="text" value="Z_-"/> Command cannot be executed: Zero-set range dropped below <input type="text" value="Z_+"/> Command cannot be executed: Zero-set range exceeded
Comments	<ul style="list-style-type: none"> • Setting to zero is not possible when the weighing platform stabilizes in the zero-set range. • With some weighing platform types setting to zero deletes a saved tare weight. This is indicated with the message TA, see section 5.1.4.

Changing over to different weight unit

Command	<input type="text" value="U_ Unit"/> Change over weight display to different weight unit <input type="text" value="U"/> Change over weight display to first weight unit
Response	<input type="text" value="U_B"/> Weight display changed over to different weight unit
Comment	Possible units: mg, g, kg, lb, ozt, oz, dwt

Tare

<p>Command</p>	<p><input type="text" value="T"/> Tare weighing platform: After the weighing platform stabilizes, the current weight value is saved as the tare weight and the weight display is set to zero with the weight placed on the platform. Effect as when TARE key is pressed.</p> <p><input type="text" value="T"/> <input data-bbox="507 539 528 568" type="text" value=" "/> Tare weight (weight value) <input data-bbox="794 539 815 568" type="text" value=" "/> Unit Specify tare weight: The content of the tare memory is overwritten with the specified tare weight and the net weight is displayed. Effect as when TARE ENTRY, 0 ... 9, ENTER key sequence is pressed.</p> <p><input type="text" value="T"/> <input data-bbox="507 725 528 754" type="text" value=" "/> Delete tare weight.</p>
<p>Response</p>	<p><input type="text" value="T"/> <input type="text" value="B"/> <input data-bbox="703 792 724 822" type="text" value=" "/> <input data-bbox="745 792 766 822" type="text" value=" "/> Tare weight (weight value) <input data-bbox="904 792 925 822" type="text" value=" "/> Unit Weighing platform is tared</p> <p><input type="text" value="T"/> <input type="text" value="B"/> <input type="text" value="H"/> <input data-bbox="936 837 957 866" type="text" value=" "/> <input data-bbox="978 837 999 866" type="text" value=" "/> Tare weight (weight value) <input data-bbox="1153 837 1174 866" type="text" value=" "/> Unit Weighing platform is tared with specified weight</p> <p><input type="text" value="T"/> <input data-bbox="507 904 528 934" type="text" value=" "/> Command cannot be executed: Tare range dropped below</p> <p><input type="text" value="T"/> <input data-bbox="507 949 528 978" type="text" value="+"/> Command cannot be executed: Tare range exceeded</p>
<p>Comments</p>	<ul style="list-style-type: none"> • Taring is only possible when the weighing platform stabilizes within the tare range. • The tare weight is always transmitted in the first weight unit. • Each taring command overwrites the content of the tare memory with the new tare weight. • Taring with an unloaded weighing platform deletes the tare memory. On some weighing platform types a zero set is carried out in the unloaded state. This is displayed with the message ZA, see section 5.1.4. • On not certified weighing systems the tare weight is automatically rounded to the current increment. • On certified weighing systems: Tare range for MultiRange only in first increment range.
<p>Example</p>	<p>Command: <input type="text" value="T"/></p> <p>Response: <input type="text" value="T"/> <input type="text" value="B"/> <input data-bbox="703 1576 724 1606" type="text" value=" "/> <input data-bbox="745 1576 766 1606" type="text" value=" "/> <input data-bbox="794 1576 815 1606" type="text" value=" "/> <input data-bbox="836 1576 857 1606" type="text" value=" "/> <input data-bbox="884 1576 904 1606" type="text" value=" "/> <input data-bbox="932 1576 952 1606" type="text" value=" "/> <input data-bbox="979 1576 1000 1606" type="text" value=" "/> <input data-bbox="1027 1576 1048 1606" type="text" value=" "/> <input data-bbox="1075 1576 1096 1606" type="text" value=" "/> <input data-bbox="1123 1576 1144 1606" type="text" value=" "/> <input data-bbox="1171 1576 1192 1606" type="text" value=" "/> <input data-bbox="1219 1576 1240 1606" type="text" value=" "/> <input data-bbox="1267 1576 1287 1606" type="text" value=" "/> <input data-bbox="1315 1576 1335 1606" type="text" value=" "/> <input data-bbox="1362 1576 1383 1606" type="text" value=" "/> <input data-bbox="1410 1576 1431 1606" type="text" value=" "/> <input data-bbox="1458 1576 1479 1606" type="text" value=" "/> <input data-bbox="1506 1576 1527 1606" type="text" value=" "/> <input data-bbox="1554 1576 1575 1606" type="text" value=" "/> <input data-bbox="1602 1576 1596 1606" type="text" value=" "/> <input data-bbox="1650 1576 1596 1606" type="text" value=" "/> <input data-bbox="1698 1576 1596 1606" type="text" value=" "/> <input data-bbox="1761 1576 1596 1606" type="text" value=" "/> <input data-bbox="1809 1576 1596 1606" type="text" value=" "/> <input data-bbox="1873 1576 1596 1606" type="text" value=" "/> <input data-bbox="1921 1576 1596 1606" type="text" value=" "/> <input data-bbox="1969 1576 1596 1606" type="text" value=" "/> <input data-bbox="2033 1576 1596 1606" type="text" value=" "/> <input data-bbox="2081 1576 1596 1606" type="text" value=" "/> <input data-bbox="2145 1576 1596 1606" type="text" value=" "/> <input data-bbox="2208 1576 1596 1606" type="text" value=" "/> <input data-bbox="2256 1576 1596 1606" type="text" value=" "/> <input data-bbox="2320 1576 1596 1606" type="text" value=" "/> <input data-bbox="2384 1576 1596 1606" type="text" value=" "/> <input data-bbox="2448 1576 1596 1606" type="text" value=" "/> <input data-bbox="2512 1576 1596 1606" type="text" value=" "/> <input data-bbox="2559 1576 1596 1606" type="text" value=" "/> <input data-bbox="2623 1576 1596 1606" type="text" value=" "/> <input data-bbox="2687 1576 1596 1606" type="text" value=" "/> <input data-bbox="2735 1576 1596 1606" type="text" value=" "/> <input data-bbox="2799 1576 1596 1606" type="text" value=" "/> <input data-bbox="2863 1576 1596 1606" type="text" value=" "/> <input data-bbox="2927 1576 1596 1606" type="text" value=" "/> <input data-bbox="2990 1576 1596 1606" type="text" value=" "/> <input data-bbox="3038 1576 1596 1606" type="text" value=" "/> <input data-bbox="3102 1576 1596 1606" type="text" value=" "/> <input data-bbox="3166 1576 1596 1606" type="text" value=" "/> <input data-bbox="3214 1576 1596 1606" type="text" value=" "/> <input data-bbox="3278 1576 1596 1606" type="text" value=" "/> <input data-bbox="3342 1576 1596 1606" type="text" value=" "/> <input data-bbox="3405 1576 1596 1606" type="text" value=" "/> <input data-bbox="3469 1576 1596 1606" type="text" value=" "/> <input data-bbox="3517 1576 1596 1606" type="text" value=" "/> <input data-bbox="3581 1576 1596 1606" type="text" value=" "/> <input data-bbox="3645 1576 1596 1606" type="text" value=" "/> <input data-bbox="3693 1576 1596 1606" type="text" value=" "/> <input data-bbox="3756 1576 1596 1606" type="text" value=" "/> <input data-bbox="3820 1576 1596 1606" type="text" value=" "/> <input data-bbox="3884 1576 1596 1606" type="text" value=" "/> <input data-bbox="3948 1576 1596 1606" type="text" value=" "/> <input data-bbox="3996 1576 1596 1606" type="text" value=" "/> <input data-bbox="4060 1576 1596 1606" type="text" value=" "/> <input data-bbox="4124 1576 1596 1606" type="text" value=" "/> <input data-bbox="4171 1576 1596 1606" type="text" value=" "/> <input data-bbox="4235 1576 1596 1606" type="text" value=" "/> <input data-bbox="4299 1576 1596 1606" type="text" value=" "/> <input data-bbox="4363 1576 1596 1606" type="text" value=" "/> <input data-bbox="4427 1576 1596 1606" type="text" value=" "/> <input data-bbox="4475 1576 1596 1606" type="text" value=" "/> <input data-bbox="4539 1576 1596 1606" type="text" value=" "/> <input data-bbox="4602 1576 1596 1606" type="text" value=" "/> <input data-bbox="4650 1576 1596 1606" type="text" value=" "/> <input data-bbox="4714 1576 1596 1606" type="text" value=" "/> <input data-bbox="4778 1576 1596 1606" type="text" value=" "/> <input data-bbox="4842 1576 1596 1606" type="text" value=" "/> <input data-bbox="4906 1576 1596 1606" type="text" value=" "/> <input data-bbox="4953 1576 1596 1606" type="text" value=" "/> <input data-bbox="5017 1576 1596 1606" type="text" value=" "/> <input data-bbox="5081 1576 1596 1606" type="text" value=" "/> <input data-bbox="5129 1576 1596 1606" type="text" value=" "/> <input data-bbox="5193 1576 1596 1606" type="text" value=" "/> <input data-bbox="5257 1576 1596 1606" type="text" value=" "/> <input data-bbox="5321 1576 1596 1606" type="text" value=" "/> <input data-bbox="5384 1576 1596 1606" type="text" value=" "/> <input data-bbox="5432 1576 1596 1606" type="text" value=" "/> <input data-bbox="5496 1576 1596 1606" type="text" value=" "/> <input data-bbox="5560 1576 1596 1606" type="text" value=" "/> <input data-bbox="5608 1576 1596 1606" type="text" value=" "/> <input data-bbox="5672 1576 1596 1606" type="text" value=" "/> <input data-bbox="5736 1576 1596 1606" type="text" value=" "/> <input data-bbox="5799 1576 1596 1606" type="text" value=" "/> <input data-bbox="5863 1576 1596 1606" type="text" value=" "/> <input data-bbox="5911 1576 1596 1606" type="text" value=" "/> <input data-bbox="5975 1576 1596 1606" type="text" value=" "/> <input data-bbox="6039 1576 1596 1606" type="text" value=" "/> <input data-bbox="6087 1576 1596 1606" type="text" value=" "/> <input data-bbox="6150 1576 1596 1606" type="text" value=" "/> <input data-bbox="6214 1576 1596 1606" type="text" value=" "/> <input data-bbox="6278 1576 1596 1606" type="text" value=" "/> <input data-bbox="6342 1576 1596 1606" type="text" value=" "/> <input data-bbox="6390 1576 1596 1606" type="text" value=" "/> <input data-bbox="6454 1576 1596 1606" type="text" value=" "/> <input data-bbox="6518 1576 1596 1606" type="text" value=" "/> <input data-bbox="6565 1576 1596 1606" type="text" value=" "/> <input data-bbox="6629 1576 1596 1606" type="text" value=" "/> <input data-bbox="6693 1576 1596 1606" type="text" value=" "/> <input data-bbox="6757 1576 1596 1606" type="text" value=" "/> <input data-bbox="6821 1576 1596 1606" type="text" value=" "/> <input data-bbox="6869 1576 1596 1606" type="text" value=" "/> <input data-bbox="6933 1576 1596 1606" type="text" value=" "/> <input data-bbox="6996 1576 1596 1606" type="text" value=" "/> <input data-bbox="7044 1576 1596 1606" type="text" value=" "/> <input data-bbox="7108 1576 1596 1606" type="text" value=" "/> <input data-bbox="7172 1576 1596 1606" type="text" value=" "/> <input data-bbox="7236 1576 1596 1606" type="text" value=" "/> <input data-bbox="7300 1576 1596 1606" type="text" value=" "/> <input data-bbox="7347 1576 1596 1606" type="text" value=" "/> <input data-bbox="7411 1576 1596 1606" type="text" value=" "/> <input data-bbox="7459 1576 1596 1606" type="text" value=" "/> <input data-bbox="7523 1576 1596 1606" type="text" value=" "/> <input data-bbox="7587 1576 1596 1606" type="text" value=" "/> <input data-bbox="7651 1576 1596 1606" type="text" value=" "/> <input data-bbox="7715 1576 1596 1606" type="text" value=" "/> <input data-bbox="7778 1576 1596 1606" type="text" value=" "/> <input data-bbox="7826 1576 1596 1606" type="text" value=" "/> <input data-bbox="7890 1576 1596 1606" type="text" value=" "/> <input data-bbox="7954 1576 1596 1606" type="text" value=" "/> <input data-bbox="8002 1576 1596 1606" type="text" value=" "/> <input data-bbox="8066 1576 1596 1606" type="text" value=" "/> <input data-bbox="8130 1576 1596 1606" type="text" value=" "/> <input data-bbox="8193 1576 1596 1606" type="text" value=" "/> <input data-bbox="8257 1576 1596 1606" type="text" value=" "/> <input data-bbox="8305 1576 1596 1606" type="text" value=" "/> <input data-bbox="8369 1576 1596 1606" type="text" value=" "/> <input data-bbox="8417 1576 1596 1606" type="text" value=" "/> <input data-bbox="8481 1576 1596 1606" type="text" value=" "/> <input data-bbox="8529 1576 1596 1606" type="text" value=" "/> <input data-bbox="8592 1576 1596 1606" type="text" value=" "/> <input data-bbox="8640 1576 1596 1606" type="text" value=" "/> <input data-bbox="8704 1576 1596 1606" type="text" value=" "/> <input data-bbox="8768 1576 1596 1606" type="text" value=" "/> <input data-bbox="8832 1576 1596 1606" type="text" value=" "/> <input data-bbox="8896 1576 1596 1606" type="text" value=" "/> <input data-bbox="8943 1576 1596 1606" type="text" value=" "/> <input data-bbox="9007 1576 1596 1606" type="text" value=" "/> <input data-bbox="9055 1576 1596 1606" type="text" value=" "/> <input data-bbox="9119 1576 1596 1606" type="text" value=" "/> <input data-bbox="9183 1576 1596 1606" type="text" value=" "/> <input data-bbox="9247 1576 1596 1606" type="text" value=" "/> <input data-bbox="9311 1576 1596 1606" type="text" value=" "/> <input data-bbox="9374 1576 1596 1606" type="text" value=" "/> <input data-bbox="9422 1576 1596 1606" type="text" value=" "/> <input data-bbox="9486 1576 1596 1606" type="text" value=" "/> <input data-bbox="9550 1576 1596 1606" type="text" value=" "/> <input data-bbox="9598 1576 1596 1606" type="text" value=" "/> <input data-bbox="9662 1576 1596 1606" type="text" value=" "/> <input data-bbox="9726 1576 1596 1606" type="text" value=" "/> <input data-bbox="9789 1576 1596 1606" type="text" value=" "/> <input data-bbox="9853 1576 1596 1606" type="text" value=" "/> <input data-bbox="9901 1576 1596 1606" type="text" value=" "/> <input data-bbox="9965 1576 1596 1606" type="text" value=" "/> <input data-bbox="10013 1576 1596 1606" type="text" value=" "/> <input data-bbox="10077 1576 1596 1606" type="text" value=" "/> <input data-bbox="10125 1576 1596 1606" type="text" value=" "/> <input data-bbox="10188 1576 1596 1606" type="text" value=" "/> <input data-bbox="10236 1576 1596 1606" type="text" value=" "/> <input data-bbox="10300 1576 1596 1606" type="text" value=" "/> <input data-bbox="10364 1576 1596 1606" type="text" value=" "/> <input data-bbox="10428 1576 1596 1606" type="text" value=" "/> <input data-bbox="10492 1576 1596 1606" type="text" value=" "/> <input data-bbox="10539 1576 1596 1606" type="text" value=" "/> <input data-bbox="10603 1576 1596 1606" type="text" value=" "/> <input data-bbox="10651 1576 1596 1606" type="text" value=" "/> <input data-bbox="10715 1576 1596 1606" type="text" value=" "/> <input data-bbox="10779 1576 1596 1606" type="text" value=" "/> <input data-bbox="10843 1576 1596 1606" type="text" value=" "/> <input data-bbox="10907 1576 1596 1606" type="text" value=" "/> <input data-bbox="10970 1576 1596 1606" type="text" value=" "/> <input data-bbox="11018 1576 1596 1606" type="text" value=" "/> <input data-bbox="11082 1576 1596 1606" type="text" value=" "/> <input data-bbox="11146 1576 1596 1606" type="text" value=" "/> <input data-bbox="11194 1576 1596 1606" type="text" value=" "/> <input data-bbox="11258 1576 1596 1606" type="text" value=" "/> <input data-bbox="11322 1576 1596 1606" type="text" value=" "/> <input data-bbox="11385 1576 1596 1606" type="text" value=" "/> <input data-bbox="11449 1576 1596 1606" type="text" value=" "/> <input data-bbox="11497 1576 1596 1606" type="text" value=" "/> <input data-bbox="11561 1576 1596 1606" type="text" value=" "/> <input data-bbox="11609 1576 1596 1606" type="text" value=" "/> <input data-bbox="11673 1576 1596 1606" type="text" value=" "/> <input data-bbox="11721 1576 1596 1606" type="text" value=" "/> <input data-bbox="11784 1576 1596 1606" type="text" value=" "/> <input data-bbox="11832 1576 1596 1606" type="text" value=" "/> <input data-bbox="11896 1576 1596 1606" type="text" value=" "/> <input data-bbox="11960 1576 1596 1606" type="text" value=" "/> <input data-bbox="12024 1576 1596 1606" type="text" value=" "/> <input data-bbox="12088 1576 1596 1606" type="text" value=" "/> <input data-bbox="12135 1576 1596 1606" type="text" value=" "/> <input data-bbox="12199 1576 1596 1606" type="text" value=" "/> <input data-bbox="12247 1576 1596 1606" type="text" value=" "/> <input data-bbox="12311 1576 1596 1606" type="text" value=" "/> <input data-bbox="12375 1576 1596 1606" type="text" value=" "/> <input data-bbox="12439 1576 1596 1606" type="text" value=" "/> <input data-bbox="12503 1576 1596 1606" type="text" value=" "/> <input data-bbox="12566 1576 1596 1606" type="text" value=" "/> <input data-bbox="12614 1576 1596 1606" type="text" value=" "/> <input data-bbox="12678 1576 1596 1606" type="text" value=" "/> <input data-bbox="12742 1576 1596 1606" type="text" value=" "/> <input data-bbox="12790 1576 1596 1606" type="text" value=" "/> <input data-bbox="12854 1576 1596 1606" type="text" value=" "/> <input data-bbox="12918 1576 1596 1606" type="text" value=" "/> <input data-bbox="12981 1576 1596 1606" type="text" value=" "/> <input data-bbox="13045 1576 1596 1606" type="text" value=" "/> <input data-bbox="13093 1576 1596 1606" type="text" value=" "/> <input data-bbox="13157 1576 1596 1606" type="text" value=" "/> <input data-bbox="13205 1576 1596 1606" type="text" value=" "/> <input data-bbox="13269 1576 1596 1606" type="text" value=" "/> <input data-bbox="13317 1576 1596 1606" type="text" value=" "/> <input data-bbox="13380 1576 1596 1606" type="text" value=" "/> <input data-bbox="13428 1576 1596 1606" type="text" value=" "/> <input data-bbox="13492 1576 1596 1606" type="text" value=" "/> <input data-bbox="13556 1576 1596 1606" type="text" value=" "/> <input data-bbox="13620 1576 1596 1606" type="text" value=" "/> <input data-bbox="13684 1576 1596 1606" type="text" value=" "/> <input data-bbox="13731 1576 1596 1606" type="text" value=" "/> <input data-bbox="13795 1576 1596 1606" type="text" value=" "/> <input data-bbox="13843 1576 1596 1606" type="text" value=" "/> <input data-bbox="13907 1576 1596 1606" type="text" value=" "/> <input data-bbox="13971 1576 1596 1606" type="text" value=" "/> <input data-bbox="14035 1576 1596 1606" type="text" value=" "/> <input data-bbox="14099 1576 1596 1606" type="text" value=" "/> <input data-bbox="14162 1576 1596 1606" type="text" value=" "/> <input data-bbox="14210 1576 1596 1606" type="text" value=" "/> <input data-bbox="14274 1576 1596 1606" type="text" value=" "/> <input data-bbox="14338 1576 1596 1606" type="text" value=" "/> <input data-bbox="14386 1576 1596 1606" type="text" value=" "/> <input data-bbox="14450 1576 1596 1606" type="text" value=" "/> <input data-bbox="14514 1576 1596 1606" type="text" value=" "/> <input data-bbox="14577 1576 1596 1606" type="text" value=" "/> <input data-bbox="14641 1576 1596 1606" type="text" value=" "/> <input data-bbox="14689 1576 1596 1606" type="text" value=" "/> <input data-bbox="14753 1576 1596 1606" type="text" value=" "/> <input data-bbox="14801 1576 1596 1606" type="text" value=" "/> <input data-bbox="14865 1576 1596 1606" type="text" value=" "/> <input data-bbox="14913 1576 1596 1606" type="text" value=" "/> <input data-bbox="14976 1576 1596 1606" type="text" value=" "/> <input data-bbox="15024 1576 1596 1606" type="text" value=" "/> <input data-bbox="15088 1576 1596 1606" type="text" value=" "/> <input data-bbox="15152 1576 1596 1606" type="text" value=" "/> <input data-bbox="15216 1576 1596 1606" type="text" value=" "/> <input data-bbox="15280 1576 1596 1606" type="text" value=" "/> <input data-bbox="15327 1576 1596 1606" type="text" value=" "/> <input data-bbox="15391 1576 1596 1606" type="text" value=" "/> <input data-bbox="15439 1576 1596 1606" type="text" value=" "/> <input data-bbox="15503 1576 1596 1606" type="text" value=" "/> <input data-bbox="15567 1576 1596 1606" type="text" value=" "/> <input data-bbox="15631 1576 1596 1606" type="text" value=" "/> <input data-bbox="15695 1576 1596 1606" type="text" value=" "/> <input data-bbox="15758 1576 1596 1606" type="text" value=" "/> <input data-bbox="15806 1576 1596 1606" type="text" value=" "/> <input data-bbox="15870 1576 1596 1606" type="text" value=" "/> <input data-bbox="15934 1576 1596 1606" type="text" value=" "/> <input data-bbox="15982 1576 1596 1606" type="text" value=" "/> <input data-bbox="16046 1576 1596 1606" type="text" value=" "/> <input data-bbox="16110 1576 1596 1606" type="text" value=" "/> <input data-bbox="16173 1576 1596 1606" type="text" value=" "/> <input data-bbox="16237 1576 1596 1606" type="text" value=" "/> <input data-bbox="16285 1576 1596 1606" type="text" value=" "/> <input data-bbox="16349 1576 1596 1606" type="text" value=" "/> <input data-bbox="16397 1576 1596 1606" type="text" value=" "/> <input data-bbox="16461 1576 1596 1606" type="text" value=" "/> <input data-bbox="16509 1576 1596 1606" type="text" value=" "/> <input data-bbox="16572 1576 1596 1606" type="text" value=" "/> <input data-bbox="16620 1576 1596 1606" type="text" value=" "/> <input data-bbox="16684 1576 1596 1606" type="text" value=" "/> <input data-bbox="16748 1576 1596 1606" type="text" value=" "/> <input data-bbox="16812 1576 1596 1606" type="text" value=" "/> <input data-bbox="16876 1576 1596 1606" type="text" value=" "/> <input data-bbox="16923 1576 1596 1606" type="text" value=" "/> <input data-bbox="16987 1576 1596 1606" type="text" value=" "/> <input data-bbox="17035 1576 1596 1606" type="text" value=" "/> <input data-bbox="17099 1576 1596 1606" type="text" value=" "/> <input data-bbox="17163 1576 1596 1606" type="text" value=" "/> <input data-bbox="17227 1576 1596 1606" type="text" value=" "/> <input data-bbox="17291 1576 1596 1606" type="text" value=" "/> <input data-bbox="17354 1576 1596 1606" type="text" value=" "/> <input data-bbox="17402 1576 1596 1606" type="text" value=" "/> <input data-bbox="17466 1576 1596 1606" type="text" value=" "/> <input data-bbox="17530 1576 1596 1606" type="text" value=" "/> <input data-bbox="17578 1576 1596 1606" type="text" value=" "/> <input data-bbox="17642 1576 1596 1606" type="text" value=" "/> <input data-bbox="17706 1576 1596 1606" type="text" value=" "/> <input data-bbox="17769 1576 1596 1606" type="text" value=" "/> <input data-bbox="17833 1576 1596 1606" type="text" value=" "/> <input data-bbox="17881 1576 1596 1606" type="text" value=" "/> <input data-bbox="17945 1576 1596 1606" type="text" value=" "/> <input data-bbox="17993 1576 1596 1606" type="text" value=" "/> <input data-bbox="18057 1576 1596 1606" type="text" value=" "/> <input data-bbox="18105 1576 1596 1606" type="text" value=" "/> <input data-bbox="18168 1576 1596 1606" type="text" value=" "/> <input data-bbox="18216 1576 1596 1606" type="text" value=" "/> <input data-bbox="18280 1576 1596 1606" type="text" value=" "/> <input data-bbox="18344 1576 1596 1606" type="text" value=" "/> <input data-bbox="18408 1576 1596 1606" type="text" value=" "/> <input data-bbox="18472 1576 1596 1606" type="text" value=" "/> <input data-bbox="18519 1576 1596 1606" type="text" value=" "/> <input data-bbox="18583 1576 1596 1606" type="text" value=" "/> <input data-bbox="18631 1576 1596 1606" type="text" value=" "/> <input data-bbox="18695 1576 1596 1606" type="text" value=" "/> <input data-bbox="18759 1576 1596 1606" type="text" value=" "/> <input data-bbox="18823 1576 1596 1606" type="text" value=" "/> <input data-bbox="18887 1576 1596 1606" type="text" value=" "/> <input data-bbox="18950 1576 1596 1606" type="text" value=" "/> <input data-bbox="18998 1576 1596 1606" type="text" value=" "/> <input data-bbox="19062 1576 1596 1606" type="text" value=" "/> <input data-bbox="19126 1576 1596 1606" type="text" value=" "/> <input data-bbox="19174 1576 1596 1606" type="text" value=" "/> <input data-bbox="19238 1576 1596 1606" type="text" value=" "/> <input data-bbox="19302 1576 1596 1606" type="text" value=" "/> <input data-bbox="19365 1576 1596 1606" type="text" value=" "/> <input data-bbox="19429 1576 1596 1606" type="text" value=" "/> <input data-bbox="19477 1576 1596 1606" type="text" value=" "/> <input data-bbox="19541 1576 1596 1606" type="text" value=" "/> <input data-bbox="19589 1576 1596 1606" type="text" value=" "/> <input data-bbox="19653 1576 1596 1606" type="text" value=" "/> <input data-bbox="19701 1576 1596 1606" type="text" value=" "/> <input data-bbox="19764 1576 1596 1606" type="text" value=" "/> <input data-bbox="19812 1576 1596 1606" type="text" value=" "/> <input data-bbox="19876 1576 1596 1606" type="text" value=" "/> <input data-bbox="19940 1576 1596 1606" type="text" value=" "/> <input data-bbox="20004 1576 1596 1606" type="text" value=" "/> <input data-bbox="20068 1576 1596 1606" type="text" value=" "/> <input data-bbox="20115 1576 1596 1606" type="text" value=" "/> <input data-bbox="20179 1576 1596 1606" type="text" value=" "/> <input data-bbox="20227 1576 1596 1606" type="text" value=" "/> <input data-bbox="20291 1576 1596 1606" type="text" value=" "/> <input data-bbox="20355 1576 1596 1606" type="text" value=" "/> <input data-bbox="20419 1576 1596 1606" type="text" value=" "/> <input data-bbox="20483 1576 1596 1606" type="text" value=" "/> <input data-bbox="20546 1576 1596 1606" type="text" value=" "/> <input data-bbox="20594 1576 1596 1606" type="text" value=" "/> <input data-bbox="20658 1576 1596 1606" type="text" value=" "/> <input data-bbox="20722 1576 1596 1606" type="text" value=" "/> <input data-bbox="20770 1576 1596 1606" type="text" value=" "/> <input data-bbox="20834 1576 1596 1606" type="text" value=" "/> <input data-bbox="20898 1576 1596 1606" type="text" value=" "/> <input data-bbox="20961 1576 1596 1606" type="text" value=" "/> <input data-bbox="21025 1576 1596 1606" type="text" value=" "/> <input data-bbox="21073 1576 1596 1606" type="text" value=" "/> <input data-bbox="21137 1576 1596 1606" type="text" value=" "/> <input data-bbox="21185 1576 1596 1606" type="text" value=" "/> <input data-bbox="21249 1576 1596 1606" type="text" value=" "/> <input data-bbox="21297 1576 1596 1606" type="text" value=" "/> <input data-bbox="21360 1576 1596 1606" type="text" value=" "/> </p>

Specify DeltaTrac target value

Command	<input type="text" value="D,Y"/> Target weight (weight value) <input type="text" value=""/> Unit <input type="text" value=""/> Tolerance <input type="text" value=""/> % Specify DeltaTrac target value <input type="text" value="D,Y"/> Delete DeltaTrac target value
Response	<input type="text" value="D,B"/> DeltaTrac target value loaded/deleted
Comments	<ul style="list-style-type: none"> Observe limit values, see section 3.1.1 Also possible: <input type="text" value="A,W,0,2,0,..."/> , see section 6.2
Example	Command: <input type="text" value="D,Y,4.5,kg,5%"/> Response: <input type="text" value="D,B"/>

Transmit content of display

Command	<input type="text" value="S"/> Transmit a stabilized weight when weighing platform is stabilized. <input type="text" value="S,I"/> Transmit a stabilized or dynamic weight independent of weighing platform stabilization.
Response	<input type="text" value="S,Weight value,Unit"/> Stabilized weight value transmitted <input type="text" value="S,D,Weight value,Unit"/> Dynamic weight value transmitted <input type="text" value="S,I"/> Invalid weight <input type="text" value="S,I,-"/> Weighing platform in underload range <input type="text" value="S,I,+"/> Weighing platform in overload range

Transmit content of display repeatedly

Command	<input type="text" value="S,I,R"/> Transmit stabilized or dynamic weight values after each measuring cycle independent of weighing platform stabilization. <input type="text" value="S,R"/> Transmit the next stabilized weight value after a weight change (e. g. different item) and one dynamic and the next stabilized weight value after each deflection > 30 d. <input type="text" value="S,R,Deflection weight (weight value),Unit"/> Transmit the next stabilized weight value and, depending on the specified deflection, a dynamic weight value after a weight change greater than the specified deflection value.
Response	<input type="text" value="S,Weight value,Unit"/> Transmit stabilized weight value repeatedly <input type="text" value="S,D,Weight value,Unit"/> Transmit dynamic weight value repeatedly
Comment	Stop command with <input type="text" value="S"/> , <input type="text" value="S,I"/> command or by interrupting the interface
Example	Command: <input type="text" value="S,R,1,4,0,kg"/> Responses: <input type="text" value="S,2,0,0.0,kg"/> 1st item <input type="text" value="S,D,3,4,5.8,kg"/> <input type="text" value="S,4,1,0.5,kg"/> 2nd item

Read application block

Command	<input type="text" value="A"/> <input type="text" value="R"/> <input type="text" value="No."/>	Read content of application block
Response	<input type="text" value="A"/> <input type="text" value="B"/> <input type="text" value="Information"/>	Content of application block transmitted
Comments	<ul style="list-style-type: none"> • Transmitted information is dependent on application block, see chapter 6. • Number of application block must be entered as 3 digits with preceding zeros. 	

Write to application block

Command	<input type="text" value="A"/> <input type="text" value="W"/> <input type="text" value="No."/> <input type="text" value="Information"/>	Write to application block
	<input type="text" value="A"/> <input type="text" value="W"/> <input type="text" value="No."/>	Reset application block
	<input type="text" value="A"/> <input type="text" value="W"/> <input type="text" value="No."/> <input type="text" value=""/>	Delete application block
Response	<input type="text" value="A"/> <input type="text" value="B"/>	Written to application block
Comments	<ul style="list-style-type: none"> • Information to be entered is dependent on target block, see chapter 6. • Deleting and resetting have same effect. 	

Write to display

Command	<input type="text" value="D"/> <input type="text" value="Text_20"/>	Write to display
	<input type="text" value="D"/> <input type="text" value=""/>	Switch display to dark
	<input type="text" value="D"/>	Set display to normal status
Response	<input type="text" value="D"/> <input type="text" value="B"/>	Written to display
Comments	<ul style="list-style-type: none"> • Character stock: ASCII characters 20 hex/32 deci ... 7F hex/127 deci, see section 9.1. • Watch capitalization. 	

Alphanumeric printout on GA46 printer (safe area)

Command	<code>P _ Text_48</code>	Print text as per setting
	<code>P _ \$! 1 Text_48</code>	Print text in small type
	<code>P _ \$! 2 Text_48</code>	Print text in normal type
	<code>P _ \$! 3 Text_48</code>	Print text in large type
	<code>P _ \$! A Text_48</code>	Print text in small type and bold print
	<code>P _ \$! B Text_48</code>	Print text in normal type and bold print
	<code>P _ \$! C Text_48</code>	Print text in large type and bold print
	<code>P _</code>	Print blank line
Response	<code>P , B</code>	Alphanumeric characters printed
Comments	<ul style="list-style-type: none"> • Character stock: ASCII characters 20 hex/32 deci ... 7F hex/127 deci, see section 9.1. • Text is printed in last selected type size. • Watch capitalization. 	

Barcode printout on GA46 printer (safe area)

Command	<code>P _ \$ # 1 Text_20, barcode-specific</code>	Print Code 39
	<code>P _ \$ # 2 Text_8, barcode-specific</code>	Print EAN 8
	<code>P _ \$ # 3 Text_13, barcode-specific</code>	Print EAN 13
	<code>P _ \$ # 4 Text_20, barcode-specific</code>	Print EAN 128
	<code>P _ \$ # 5 Text_20, barcode-specific</code>	Print Code 2 of 5
	<code>P _ \$ # 6 Text_20, barcode-specific</code>	Print Code 2 of 5 interleaved
	<code>P _ \$ # 7 Text_20, barcode-specific</code>	Print Code 128
	<code>P _ \$ # 8 Text_20, barcode-specific</code>	Print EAN 128
	<code>P _</code>	Print blank line
Response	<code>P , B</code>	Barcode printed
Comments	<ul style="list-style-type: none"> • Character stock: ASCII characters 20 hex/32 deci ... 7F hex/127 deci, see section 9.1. • With Code 39, 3 barcodes can be printed next to each other. Separating characters: \$\$ or H_T (ASCII character 09 hex/9 deci). Arrangement of barcodes: Barcode 2, Barcode 1, Barcode 3. 	

Acoustic signal

Command	<code>D , S</code>	Generate short acoustic signal (beep tone) in terminal
Response	<code>D , B</code>	Acoustic signal generated in terminal

Identification

Command	<code>I , D</code>	Interrogate identification of terminal
Response	<code>I , D , 7 _</code>	Program number of Pac

Actuating digital outputs

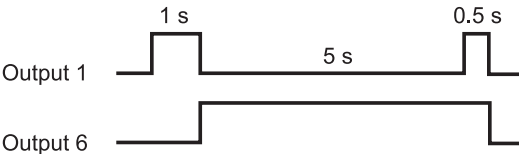
<p>Command</p>	<p><code>W _ Status</code> Switch individual digital outputs on or off</p> <p><code>W _ Status 1 _ Time 1 _ Status 2 _ Time 2 _ ... _ Status 4 _ Time 4 _ Status 5</code> Trigger time sequence of status changes of digital outputs</p> <p><code>W , W _</code> Reset all outputs to logical 0</p> <p>Status: Each output is assigned a value. The total of the values of those outputs which are to be closed is indicated as the "Status".</p> <table border="0"> <tr><td>Digital output 1</td><td>1</td></tr> <tr><td>Digital output 2</td><td>2</td></tr> <tr><td>Digital output 3</td><td>4</td></tr> <tr><td>Digital output 4</td><td>8</td></tr> <tr><td>Digital output 5</td><td>16</td></tr> <tr><td>Digital output 6</td><td>32</td></tr> <tr><td>Digital output 7</td><td>64</td></tr> <tr><td>Digital output 8</td><td>128</td></tr> <tr><td>All outputs open</td><td>0</td></tr> <tr><td>All outputs closed</td><td>255</td></tr> </table> <p>Time: 1 ... 99999 ms</p>	Digital output 1	1	Digital output 2	2	Digital output 3	4	Digital output 4	8	Digital output 5	16	Digital output 6	32	Digital output 7	64	Digital output 8	128	All outputs open	0	All outputs closed	255
Digital output 1	1																				
Digital output 2	2																				
Digital output 3	4																				
Digital output 4	8																				
Digital output 5	16																				
Digital output 6	32																				
Digital output 7	64																				
Digital output 8	128																				
All outputs open	0																				
All outputs closed	255																				
<p>Response</p>	<p><code>W B</code> Digital outputs set</p>																				
<p>Comments</p>	<ul style="list-style-type: none"> • Max. 5 statuses "Status" and 4 intervals "Time" are possible. After sequence has been run, digital outputs freeze in last status "Status". • A break in the port has no effect on the outputs. • If terminal receives a new W command before time sequence has been run, ongoing sequence will be aborted immediately. 																				
<p>Examples</p>	<p>Command: <code>W _ 5</code> Digital outputs 1 and 3 are closed, all others opened</p> <p>Command: <code>W _ 1 _ 1,0,0,0 _ 3,2 _ 5,0,0,0 _ 3,3 _ 5,0,0 _ 0</code> triggers following sequence:</p>  <p>The diagram shows two digital signals over time. Output 1 starts low, goes high for 1 second, then low for 5 seconds, then high for 0.5 seconds. Output 6 starts low, goes high for 5 seconds, then low.</p>																				

5.1.4 Terminal messages – only with CL20mA and RS232

In the dialog mode the ID7sx-Base weighing terminal transmits an acknowledgement to the computer each time a key is pressed.

When this pressing of a key is replaced with an interface command, the acknowledgement only differs in the second character in the response format which is part of the command:

Function	Key	Acknowledgement
Set zero		Z, A
Tare		T, A ... (see command T)
Specify tare weight		T, A, H ... (see command T_ ...)
Change over unit		U, A, _ Unit
Transmit data record in case of weighing platform stabilization		S, T, _ _ ... (see command SX)
Switch over weighing platform		S, A, _ _ n n = weighing platform 1 ... 3
Dynamic weighing		A, A, 0, 1, 6 _ Weight value _ Unit
Identification A ... D	A ... D	K, x _ Identification x = A, B, C, D 20 characters, right-justified
Function keys	F1 ... F6	K, F _ x x = I, J, K, L, M, N

5.1.5 Fault messages

Fault messages always consist of 2 characters and a string frame.

The string frame can be defined in the master mode (section 4.5.1).

E, T

Transmission error

The terminal transmits a transmission error for errors in the received bit sequence, e. g. parity errors, missing stop bit.

E, S

Syntax error

The terminal transmits a syntax error when the received characters cannot be processed, e. g. command does not exist.

E, L

Logic error

The terminal transmits a logic error when a command cannot be executed, e. g. when an attempt is made to write to a write-protected application block.

5.2 METTLER TOLEDO continuous mode

These operating modes are suitable for continuous data transmission in real time from the ID7sx-Base to METTLER TOLEDO devices, e. g. to a second display.

The data are even transmitted when the weighing platform is moving or the gross weight = 0.

Commands can also be sent to the ID7sx-Base weighing terminal, permitting remote control of certain keys on the terminal.

There are 2 different continuous modes:

- Continuous mode – net and tare values are continuously transmitted.
- Short continuous mode – only net values are continuously transmitted.

5.2.1 Data output from ID7sx-Base

Output format

Weight values are always transmitted in the following format:

STX	SB1	SB2	SB3	DF1	DF2	CR	CHK
-----	-----	-----	-----	-----	-----	----	-----

STX ASCII characters 02 hex/2 deci, character for "start of text" is required by some printers

SB... For status bytes, see below

DF1 Data field with 6 digits for the weight value transmitted without a decimal point and unit

DF2 Data field with 6 digits for the tare weight; is not transmitted in the short continuous mode

CR Carriage return (ASCII character 0D hex/13 deci)

CHK Checksum (2-part complement of binary sum of 7 lower bits of all previously transmitted characters, including STX and CR)

Status byte SB1

Bit 6	Bit 5	Bit 4	Bit 3	Bit 2	Bit 1	Bit 0
0	1	Rounding / Increment		Decimal position		

Bit 4	Bit 3	Rounding/ Increment
0	1	1
1	0	2
1	1	5

Bit 2	Bit 1	Bit 0	Decimal position
0	0	0	XXXX00
0	0	1	XXXXX0
0	1	0	XXXXXX
0	1	1	XXXXX.X
1	0	0	XXXX.XX
1	0	1	XXX.XXX
1	1	0	XX.XXXX
1	1	1	X.XXXXX

Status byte SB2

Bit 6	Bit 5	Bit 4	Bit 3	Bit 2	Bit 1	Bit 0
0	1	0 lb	0 Stabiliza- tion	0 Normal status	0 Positive sign	0 Gross value
		1 kg	1 Movement	1 Underload/ overload	1 Negative sign	1 Net value

Status byte SB3

Bit 6	Bit 5	Bit 4	Bit 3	Bit 2	Bit 1	Bit 0
0	1	0	0 Basic state 1 Print request	Weight value		

Bit 2	Bit 1	Bit 0	Weight value
0	0	0	kg / lb (SB2 Bit 4)
0	0	1	g
0	1	0	t
0	1	1	oz
1	0	0	ozt
1	0	1	dwt
1	1	0	ton
1	1	1	free unit

5.2.2 Commands to ID7sx-Base

Individual command characters can be transmitted to the ID7sx-Base in the text format. One function each on the terminal is assigned to these command characters. After a command character is received, the following functions are executed:

Command	Function
C	Clear tare
P	Print or transmit transfer string
T	Tare
Z	Set zero

5.3 METTLER TOLEDO SICS command set

5.3.1 Communication syntax and formats

Command format when transmitting weight values

Identification	_	Weight value	_	Unit	Framing
String of characters for specification of command (1 ... 4 characters)		1 ... 10 characters		1 ... 3 characters, number of characters variable	C _R L _F

Response format when transmitting weight values

Identification	_	Status	_	Weight value	_	Unit	Framing
String of characters for specification of response (1 ... 2 char.)		1 char.		10 char., right-justified, filled in with blank char.		3 char., left-justified, filled in with blank char.	C _R L _F

Example

Tare specification command

T|A|_|1|3|.2|9|5|_|k|g|

Tare specification response

T|A|_|A|_|_|_|_|_|1|3|.2|9|5|_|k|g|_|

Data formats

- The following symbols are used in the command description:

<u>Weight value</u>	10 numbers with sign and decimal point, right-justified (with preceding blank spaces)
<u>Unit</u>	3 characters, left-justified (with following blank spaces)
<u>"Text_n"</u>	maximum of n characters, left-justified

- The string framing is mandatory, however it is **not** listed in the following command description!
- Enter commands as upper-case letters.
- Text to be entered must always be placed in inverted commas.

5.3.2 Command overview

Command	Meaning	Page
Level 0		
I0	Transmit list of all available SICS commands	65
I1	Transmit SICS level and SICS versions	65
I2	Transmit scale data (terminal, platform)	65
I3	Transmit scale software version (program number)	66
I4	Transmit serial number	66
S, SI, SIR	Transmit display contents	66
Z	Set to zero	67
@	Reset	67
Level 1		
D	Write display	67
DW	Weight display	67
K	Keyboard monitoring	68
SR	Transmit stable weight values repeatedly depending on a weight change	70
T	Taring	70
TI	Tare immediately	71
TA	Specify tare weight	71
TAC	Delete tare weight	72
Level 2		
SX, SXI, SXIR	Transmit data record	72
RO, R1	Switch keyboard on or off	73
U	Change over to different weight unit	73
DS	Acoustic signal	73
Level 3		
AR	Read application block	73
AW	Write application block	74
DY	Specify DeltaTrack target value	74
P	Print text or barcode	75
W	Actuating digital outputs	76

5.3.3 Command description

Transmit SICS commands

Command	<code>I,0</code> Transmit SICS commands
Response	<code>I,0 _ B</code> <code>I,0 _ 0 _ "I0"</code> <code>I,0 _ 0 _ "I1"</code> ... <code>I,0 _ 1 _ "D"</code> ... <code>I,0 _ 2 _ "SX"</code> ... <code>I,0 _ 3 _ "AR"</code> ... <code>I,0 _ A</code>

Transmit SICS levels and SICS versions

Command	<code>I,1</code> Transmit SICS levels and SICS versions
Response	<code>I,1 _ A _ "x1" _ "x2" _ "x3" _ "x4" _ "x5"</code> x1 = 0123 Scale with SICS levels 0, 1, 2 and 3 x2 Version or implemented SICS0 commands x3 Version or implemented SICS1 commands x4 Version or implemented SICS2 commands x5 Version or implemented SICS3 commands <code>I,1 _ I</code> Command understood, cannot be executed at this time
Comments	<ul style="list-style-type: none"> • On the SICS level only fully implemented levels are executed. • With the SICS version all levels are specified.

Transmit scale data

Command	<code>I,2</code> Transmit data from weighing terminal and weighing platform(s)
Response	<code>I,2 _ A _ "text"</code>
Example	<code>I,2 _ A _ "ID7sx-Base IZ 18 32.000 kg"</code>

Transmit scale software version

Command	<code>I,3</code> Transmit software version from weighing terminal and weighing platform(s)
Response	<code>I,3 _ A _ "text"</code>
Example	<code>I,3 _ A _ "IPYA-0-0100 IZ19-0-0103"</code>

Transmit serial number

Command	<code>I,4</code> Transmit serial number of weighing terminal
Response	<code>I,4 _ A _ "text"</code>
Example	<code>I,4 _ A _ "1234567"</code>
Comment	The response to I4 appears automatically following switch-on and after the Reset command (@).

Transmit display contents

Command	<p><code>S</code> Transmit a stabile weight value when the weighing platform is at a standstill.</p> <p><code>S,I</code> Transmit a stabile or a dynamic weight value, regardless of whether the weighing platform is at a standstill.</p> <p><code>S,I,R</code> Transmit a stabile or a dynamic weight value after each measuring cycle, regardless of whether the weighing platform is at a standstill.</p>
Response	<p><code>S _ S _ Weight value _ Unit</code> Stabile weight value transmitted</p> <p><code>S _ D _ Weight value _ Unit</code> Dynamic weight value transmitted</p> <p><code>S _ I</code> Invalid value</p> <p><code>S _ -</code> Weighing platform in underload range</p> <p><code>S _ +</code> Weighing platform in overload range</p>
Comment	Stop <code>S,I,R</code> command with <code>S</code> , <code>S,I</code> , <code>S,R</code> , @ command or disconnect port.

Set to zero

Command	<code>Z</code>	Set gross weight display to zero after weighing platform comes to a standstill, effect as when ZERO-SET key is pressed
Response	<code>Z _ A</code> <code>Z _ I</code> <code>Z _ -</code> <code>Z _ +</code>	Weighing platform set to zero Command cannot be executed: e.g. standstill not achieved or another command is currently being executed Command cannot be executed: Zero-set range dropped below Command cannot be executed: Zero-set range exceeded
Comment	Can only be set to zero when the weighing platform comes to a standstill in the zero-set range.	

Reset

Command	<code>@</code>	Reset weighing terminal to the state maintained after Power On
Response	<code>I 4 _ A _ "text"</code>	Serial number
Comments	<ul style="list-style-type: none"> • All running applications and functions are cancelled. • The tare memory is reset to zero. 	

Write display

Command	<code>D _ "Text_20"</code> <code>D _ ""</code>	Write display Darken display
Response	<code>D _ A</code> <code>D _ A</code> <code>D _ I</code> <code>D _ L</code>	Display written; the complete text appears left-justified in the display, marked with a symbol, e.g. with * Display written; the end of the text appears left-justified in the display with the beginning cut off, marked with a symbol, e.g. with * Command cannot be executed Command understood, parameters defective
Comment	A symbol in the display, e.g. *, indicates that an invalid weight value is displayed.	

Weight display

Command	<code>D W</code>	Switch over main display into the weight mode
Response	<code>D W _ A</code> <code>D W _ I</code>	The main display shows the current weight value Command understood, but cannot be executed

Keyboard monitoring

Command	<p><input type="text" value="K _ _ 1"/> When a key is pressed, execute the function, but do not transmit anything (factory setting)</p> <p><input type="text" value="K _ _ 1"/> When a key is pressed, do not execute the function and do not transmit anything</p> <p><input type="text" value="K _ _ 3"/> When a key is pressed, do not execute the function, but transmit the key code <input type="text" value="K _ _ C _ _ x"/> or, when the key is pressed longer, transmit <input type="text" value="K _ _ R _ _ x"/> and <input type="text" value="K _ _ C _ _ x"/></p> <p><input type="text" value="K _ _ 4"/> When a key is pressed, execute the function and transmit the function code <input type="text" value="K _ _ A _ _ x"/>. If the function cannot be executed immediately, the function code for the start of the function <input type="text" value="K _ _ B _ _ x"/> or <input type="text" value="K _ _ A _ _ x"/> for the end of the function is transmitted.</p>
Response	<p><input type="text" value="K _ _ A"/> Command understood or function successfully executed</p> <p><input type="text" value="K _ _ I"/> Command understood, but currently cannot be executed, e.g. no keyboard present</p> <p><input type="text" value="K _ _ L"/> Command understood, parameters defective</p> <p>Key codes</p> <p><input type="text" value="K _ _ R _ _ x"/> Key x was pressed briefly and released again immediately</p> <p><input type="text" value="K _ _ C _ _ x"/> Key x was pressed for approx. 2 sec.</p>

Response	<p>Function codes x</p> <p>The function codes are dependent on the command transmitted.</p> <table border="0"> <tr> <td>x $\boxed{K}_{-,-,3}$</td> <td>x $\boxed{K}_{-,-,4}$</td> </tr> <tr> <td>1 Set to zero</td> <td>1 Tare</td> </tr> <tr> <td>2 X 10</td> <td>2 Set to zero</td> </tr> <tr> <td>3 Switch on/off, tare</td> <td>3 Transfer key</td> </tr> <tr> <td>4 Enter master mode</td> <td>4 Enter master mode</td> </tr> <tr> <td>5 Transfer key</td> <td>5 Exit master mode</td> </tr> <tr> <td>6 F1</td> <td>7 Test</td> </tr> <tr> <td>7 F2</td> <td>10 Unit switchover</td> </tr> <tr> <td>8 F3, unit switchover</td> <td>11 X 10</td> </tr> <tr> <td>9 F4, but not X10</td> <td>12 RESET ALL</td> </tr> <tr> <td>10 F5</td> <td>13 F1</td> </tr> <tr> <td>11 F6, but not MODE</td> <td>14 F2</td> </tr> <tr> <td>21 CODE A</td> <td>15 F3</td> </tr> <tr> <td>22 CODE B</td> <td>16 F4</td> </tr> <tr> <td>23 CODE C</td> <td>17 F5</td> </tr> <tr> <td>24 CODE D</td> <td>18 F6</td> </tr> <tr> <td>25 Function change key</td> <td>21 CODE A</td> </tr> <tr> <td>26 INFO</td> <td>22 CODE B</td> </tr> <tr> <td>27 SCALE</td> <td>23 CODE C</td> </tr> <tr> <td>28 +/-</td> <td>24 CODE D</td> </tr> <tr> <td>29 Decimal point</td> <td>25 Function change key</td> </tr> <tr> <td>30 0</td> <td>26 INFO</td> </tr> <tr> <td>... ...</td> <td>27 SCALE</td> </tr> <tr> <td>39 9</td> <td>28 +/-</td> </tr> <tr> <td>40 CLEAR</td> <td>29 Decimal point</td> </tr> <tr> <td></td> <td>30 0</td> </tr> <tr> <td></td> <td>... ...</td> </tr> <tr> <td></td> <td>39 9</td> </tr> <tr> <td></td> <td>40 CLEAR</td> </tr> </table>	x $\boxed{K}_{-,-,3}$	x $\boxed{K}_{-,-,4}$	1 Set to zero	1 Tare	2 X 10	2 Set to zero	3 Switch on/off, tare	3 Transfer key	4 Enter master mode	4 Enter master mode	5 Transfer key	5 Exit master mode	6 F1	7 Test	7 F2	10 Unit switchover	8 F3, unit switchover	11 X 10	9 F4, but not X10	12 RESET ALL	10 F5	13 F1	11 F6, but not MODE	14 F2	21 CODE A	15 F3	22 CODE B	16 F4	23 CODE C	17 F5	24 CODE D	18 F6	25 Function change key	21 CODE A	26 INFO	22 CODE B	27 SCALE	23 CODE C	28 +/-	24 CODE D	29 Decimal point	25 Function change key	30 0	26 INFO	27 SCALE	39 9	28 +/-	40 CLEAR	29 Decimal point		30 0			39 9		40 CLEAR
x $\boxed{K}_{-,-,3}$	x $\boxed{K}_{-,-,4}$																																																										
1 Set to zero	1 Tare																																																										
2 X 10	2 Set to zero																																																										
3 Switch on/off, tare	3 Transfer key																																																										
4 Enter master mode	4 Enter master mode																																																										
5 Transfer key	5 Exit master mode																																																										
6 F1	7 Test																																																										
7 F2	10 Unit switchover																																																										
8 F3, unit switchover	11 X 10																																																										
9 F4, but not X10	12 RESET ALL																																																										
10 F5	13 F1																																																										
11 F6, but not MODE	14 F2																																																										
21 CODE A	15 F3																																																										
22 CODE B	16 F4																																																										
23 CODE C	17 F5																																																										
24 CODE D	18 F6																																																										
25 Function change key	21 CODE A																																																										
26 INFO	22 CODE B																																																										
27 SCALE	23 CODE C																																																										
28 +/-	24 CODE D																																																										
29 Decimal point	25 Function change key																																																										
30 0	26 INFO																																																										
... ...	27 SCALE																																																										
39 9	28 +/-																																																										
40 CLEAR	29 Decimal point																																																										
	30 0																																																										
																																																										
	39 9																																																										
	40 CLEAR																																																										
Comments	<ul style="list-style-type: none"> • The factory setting is active after switch-on, after the Reset command and after exiting the master mode. • Only one K command is ever active at one time. 																																																										

Transmit stable weight values repeatedly depending on a weight change

Command	<p><code>S,R</code> <code>Excursion weight (weight value)</code> <code>Unit</code></p> <p>After a weight change greater than the specified excursion weight, transmit alternately the next stable weight value and a dynamic weight value depending on the specified excursion.</p> <p><code>S,R</code></p> <p>If no excursion weight is entered, the weight change must be at least 12.5 % of the last stable weight value, however at least 30 d.</p>
Response	<p><code>S</code> <code>S</code> <code>Weight value</code> <code>Unit</code> Current stable weight value transmitted</p> <p>Weight change</p> <p><code>S</code> <code>D</code> <code>Weight value</code> <code>Unit</code> Dynamic weight value transmitted</p> <p><code>S</code> <code>I</code> Command cannot be executed</p> <p><code>S</code> <code>L</code> Command understood, parameters defective</p> <p><code>S</code> <code>-</code> Weighing platform in underload range</p> <p><code>S</code> <code>+</code> Weighing platform in overload range</p>
Comment	Stop command with command <code>S</code> , <code>S,I</code> , <code>S,I,R</code> , <code>@</code> or disconnect the port.
Example	<p>Command: <code>S,R</code> <code>1,4,0</code> <code>k,g</code></p> <p>Responses: <code>S</code> <code>S</code> <code>2,0,0.0,0</code> <code>k,g</code> 1st item</p> <p><code>S</code> <code>D</code> <code>3,4,5.8,5</code> <code>k,g</code></p> <p><code>S</code> <code>S</code> <code>4,1,0.5,0</code> <code>k,g</code> 2nd item</p>

Taring

Command	<p><code>T</code></p> <p>Tare weighing platform:</p> <p>After the weighing platform comes to a standstill, the current weight value is saved as a tare weight and the weight display set to zero with the weight on the platform.</p> <p>Effect as when TARE key is pressed.</p>
Response	<p><code>T</code> <code>S</code> <code>Tare weight (weight value)</code> <code>Unit</code> Weighing platform tared, stable tare value</p> <p><code>T</code> <code>I</code> Taring not carried out</p> <p><code>T</code> <code>-</code> Command cannot be executed: Tare range dropped below</p> <p><code>T</code> <code>+</code> Command cannot be executed: Tare range exceeded</p>
Comments	<ul style="list-style-type: none"> • Each taring command overwrites the contents of the tare memory with the new tare weight. • Taring with unloaded weighing platform clears the tare memory. On some weighing platform models, setting to zero is carried out in the unloaded state. • On non-certified weighing systems the tare weight is automatically rounded off to the current increment. • On certified weighing systems: Tare range with MultiRange only in first increment range.

Tare immediately

Command	<code>T, I</code> Tare weighing platform immediately.
Response	<code>T, I, S, Tare weight (weight value), Unit</code> Weighing platform tared, stabile tare value <code>T, I, D, Tare weight (weight value), Unit</code> Weighing platform tared, dynamic tare value <code>T, I, I</code> Taring not carried out <code>T, I, L</code> Command cannot be executed <code>T, I, -</code> Command cannot be executed: Tare range dropped below <code>T, I, +</code> Command cannot be executed: Tare range exceeded
Comments	<ul style="list-style-type: none"> • Each taring command overwrites the contents of the tare memory with the new tare weight. • Following a dynamic tare value, a stabile weight value can be specified. However, this value is not exact.

Specify tare weight

Command	<code>T, A, Tare weight (weight value), Unit</code> Specify tare weight: The contents of the tare memory are overwritten with the specified tare weight and the net weight is displayed. Effect as when the key sequence TARE ENTRY, 0 ... 9, ENTER is pressed.
Response	<code>T, A, A, Tare weight (weight value), Unit</code> Weighing platform tared with the specified value <code>T, A, I</code> Command not carried out <code>T, A, L</code> Command understood, parameters defective <code>T, -</code> Command cannot be executed: Tare range dropped below <code>T, +</code> Command cannot be executed: Tare range exceeded
Comments	<ul style="list-style-type: none"> • The contents of the tare memory are overwritten with the specified tare value. • On non-certified weighing systems the tare weight is automatically rounded off to the current increment. • On certified weighing systems: Tare range with MultiRange only in first increment range.
Example	Command: <code>T, A, 1, 2, ., 6, 5, 0, k, g</code> Response: <code>T, A, A, ., ., ., ., 1, 2, ., 6, 5, 0, k, g, .</code>

Delete tare weight

Command	<code>T A C</code>	Delete tare weight.
Response	<code>T A C A</code> <code>T A C I</code>	Weighing platform tared with the specified weight Command not carried out

Transmit data record

Command	<p><code>S X</code> After the weighing platform comes to a standstill, transmit a data record with stable weight values. Effect as when ENTER key is pressed.</p> <p><code>S X I</code> Transmit a data record with stable or dynamic weight values, regardless of whether the weighing platform is at a standstill.</p> <p><code>S X I R</code> Repeatedly transmit a data record with stable or dynamic weight values, regardless of whether the weighing platform is at a standstill.</p>
Response	<p><code>S X S</code> Application block Application block ... A No. Data record Data record with stable weight values transmitted</p> <p><code>S X D</code> Application block Application block ... A No. Data record Data record with dynamic weight values transmitted</p> <p><code>S X I</code> Command cannot be executed <code>S X -</code> Weighing platform in underload range <code>S X +</code> Weighing platform in overload range</p>
Comments	<ul style="list-style-type: none"> • Number of application blocks: three-place with preceding zeros. • The contents of the corresponding application block is contained in the data record, see chapter 6. The standard data record consists of 3 blocks: <code>S X S A 0 1 1</code> Gross weight (weight value) Unit <code>A 0 1 2</code> Net weight (weight value) Unit <code>A 0 1 3</code> Tare weight (weight value) Unit <p>The continuous transmission of data records started with the <code>S X I R</code> command can be stopped with the commands <code>S X</code> or <code>S X I</code>.</p>
Example	<p>Command: <code>S X I</code></p> <p>Response: Default data record</p> <pre> S X D A 0 1 1 _ _ _ _ _ 2 3 . 6 5 0 _ k g _ _ _ A 0 1 2 _ _ _ _ _ 2 1 . 6 5 0 _ k g _ _ _ A 0 1 3 _ _ _ _ _ 2 . 0 0 0 _ k g _ </pre>

Switch keyboard on or off

Command	<input type="text" value="R,0"/> Switch on keyboard <input type="text" value="R,1"/> Switch off keyboard
Response	<input type="text" value="R,0 _ _ A"/> Keyboard switched on <input type="text" value="R,1 _ _ A"/> Keyboard switched off
Comments	<ul style="list-style-type: none"> • Factory setting: Keyboard switched on. • When the keyboard is switched off, the terminal cannot be manually operated.

Changing over to different weight unit

Command	<input type="text" value="U _ Unit"/> Change over weight display to different weight unit <input type="text" value="U"/> Change over weight display to the first weight unit
Response	<input type="text" value="U _ _ A"/> Weight display switched over to another weight unit <input type="text" value="U _ _ I"/> Impermissible weight unit
Comment	Possible units: mg, g, kg, lb, ozt, oz, dwt

Acoustic signal

Command	<input type="text" value="D,S"/> Generate short acoustic signal (beep) in the terminal
Response	<input type="text" value="D,S _ _ A"/> Acoustic signal generated in the terminal

Read application block

Command	<input type="text" value="A,R _ _ No."/> Read contents of the application block
Response	<input type="text" value="A,R _ _ A _ Information"/> Contents of the application block transmitted
Comments	<ul style="list-style-type: none"> • The transmitted information is dependent on the application block, see chapter 6. • The number of the application block must be entered as a three-place number with preceding zeros.

Print text or barcode with GA46 printer (safe area)

Command	<table border="0"> <tr> <td><code>P _ Text_48</code></td> <td>Print text as per setting</td> </tr> <tr> <td><code>P _ \$! 1 Text_48</code></td> <td>Print text in small print</td> </tr> <tr> <td><code>P _ \$! 2 Text_48</code></td> <td>Print text in normal print</td> </tr> <tr> <td><code>P _ \$! 3 Text_48</code></td> <td>Print text in large print</td> </tr> <tr> <td><code>P _ \$! A Text_48</code></td> <td>Print text in small type and bold print</td> </tr> <tr> <td><code>P _ \$! B Text_48</code></td> <td>Print text in normal type and bold print</td> </tr> <tr> <td><code>P _ \$! C Text_48</code></td> <td>Print text in large type and bold print</td> </tr> <tr> <td><code>P _ \$ # 1 Text_20, barcode-specific</code></td> <td>Print code 39</td> </tr> <tr> <td><code>P _ \$ # 2 Text_8, barcode-specific</code></td> <td>Print EAN 8</td> </tr> <tr> <td><code>P _ \$ # 3 Text_13, barcode-specific</code></td> <td>Print EAN 13</td> </tr> <tr> <td><code>P _ \$ # 4 Text_20, barcode-specific</code></td> <td>Print code 128</td> </tr> <tr> <td><code>P _ \$ # 5 Text_20, barcode-specific</code></td> <td>Print code 2 of 5</td> </tr> <tr> <td><code>P _ \$ # 6 Text_20, barcode-specific</code></td> <td>Print code 2 of 5 interleaved</td> </tr> <tr> <td><code>P _ \$ # 7 Text_20, barcode-specific</code></td> <td>Print code 128</td> </tr> <tr> <td><code>P _ \$ # 8 Text_20, barcode-specific</code></td> <td>Print EAN 128</td> </tr> <tr> <td><code>P _</code></td> <td>Print blank line</td> </tr> </table>	<code>P _ Text_48</code>	Print text as per setting	<code>P _ \$! 1 Text_48</code>	Print text in small print	<code>P _ \$! 2 Text_48</code>	Print text in normal print	<code>P _ \$! 3 Text_48</code>	Print text in large print	<code>P _ \$! A Text_48</code>	Print text in small type and bold print	<code>P _ \$! B Text_48</code>	Print text in normal type and bold print	<code>P _ \$! C Text_48</code>	Print text in large type and bold print	<code>P _ \$ # 1 Text_20, barcode-specific</code>	Print code 39	<code>P _ \$ # 2 Text_8, barcode-specific</code>	Print EAN 8	<code>P _ \$ # 3 Text_13, barcode-specific</code>	Print EAN 13	<code>P _ \$ # 4 Text_20, barcode-specific</code>	Print code 128	<code>P _ \$ # 5 Text_20, barcode-specific</code>	Print code 2 of 5	<code>P _ \$ # 6 Text_20, barcode-specific</code>	Print code 2 of 5 interleaved	<code>P _ \$ # 7 Text_20, barcode-specific</code>	Print code 128	<code>P _ \$ # 8 Text_20, barcode-specific</code>	Print EAN 128	<code>P _</code>	Print blank line
<code>P _ Text_48</code>	Print text as per setting																																
<code>P _ \$! 1 Text_48</code>	Print text in small print																																
<code>P _ \$! 2 Text_48</code>	Print text in normal print																																
<code>P _ \$! 3 Text_48</code>	Print text in large print																																
<code>P _ \$! A Text_48</code>	Print text in small type and bold print																																
<code>P _ \$! B Text_48</code>	Print text in normal type and bold print																																
<code>P _ \$! C Text_48</code>	Print text in large type and bold print																																
<code>P _ \$ # 1 Text_20, barcode-specific</code>	Print code 39																																
<code>P _ \$ # 2 Text_8, barcode-specific</code>	Print EAN 8																																
<code>P _ \$ # 3 Text_13, barcode-specific</code>	Print EAN 13																																
<code>P _ \$ # 4 Text_20, barcode-specific</code>	Print code 128																																
<code>P _ \$ # 5 Text_20, barcode-specific</code>	Print code 2 of 5																																
<code>P _ \$ # 6 Text_20, barcode-specific</code>	Print code 2 of 5 interleaved																																
<code>P _ \$ # 7 Text_20, barcode-specific</code>	Print code 128																																
<code>P _ \$ # 8 Text_20, barcode-specific</code>	Print EAN 128																																
<code>P _</code>	Print blank line																																
Response	<table border="0"> <tr> <td><code>P _ A</code></td> <td>Alphanumeric characters printed</td> </tr> <tr> <td><code>P _ L</code></td> <td>no GA46 present</td> </tr> </table>	<code>P _ A</code>	Alphanumeric characters printed	<code>P _ L</code>	no GA46 present																												
<code>P _ A</code>	Alphanumeric characters printed																																
<code>P _ L</code>	no GA46 present																																
Comments	<ul style="list-style-type: none"> • Character stock: ASCII character 20 hex/32 dec ... 7F hex/127 dec, see section 9.1. • Printing is carried out in the font size last selected. • Watch uppercase and lowercase letters. 																																

Actuating digital outputs (safe area)

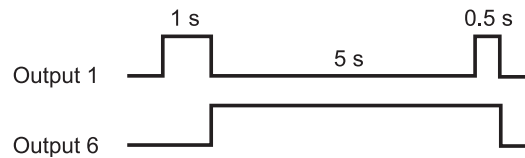
<p>Command</p>	<p><code>W _ Status</code> Switch individual digital outputs on or off</p> <p><code>W _ Status 1 _ Time 1 _ Status 2 _ Time 2 _ ... Status 4 _ Time 4 _ Status 5</code> Trigger time sequence of status changes of digital outputs</p> <p><code>W , W _</code> Reset all outputs to logical 0</p> <p>Status: Each output is assigned a value. The total of the values of those outputs which are to be closed is indicated as the "Status".</p> <table border="0"> <tr><td>Digital output 1</td><td>1</td></tr> <tr><td>Digital output 2</td><td>2</td></tr> <tr><td>Digital output 3</td><td>4</td></tr> <tr><td>Digital output 4</td><td>8</td></tr> <tr><td>Digital output 5</td><td>16</td></tr> <tr><td>Digital output 6</td><td>32</td></tr> <tr><td>Digital output 7</td><td>64</td></tr> <tr><td>Digital output 8</td><td>128</td></tr> <tr><td>All outputs open</td><td>0</td></tr> <tr><td>All outputs closed</td><td>255</td></tr> </table> <p>Time: 1 ... 99999 ms</p>	Digital output 1	1	Digital output 2	2	Digital output 3	4	Digital output 4	8	Digital output 5	16	Digital output 6	32	Digital output 7	64	Digital output 8	128	All outputs open	0	All outputs closed	255
Digital output 1	1																				
Digital output 2	2																				
Digital output 3	4																				
Digital output 4	8																				
Digital output 5	16																				
Digital output 6	32																				
Digital output 7	64																				
Digital output 8	128																				
All outputs open	0																				
All outputs closed	255																				
<p>Response</p>	<p><code>W _ A</code> Digital outputs set</p>																				
<p>Comments</p>	<ul style="list-style-type: none"> • Max. 5 statuses "Status" and 4 intervals "Time" are possible. After sequence has been run, digital outputs freeze in last status "Status". • A break in the port has no effect on the outputs. • If terminal receives a new W command before time sequence has been run, ongoing sequence will be aborted immediately. 																				
<p>Examples</p>	<p>Command: <code>W _ 5</code> Digital outputs 1 and 3 are closed, all others opened</p> <p>Command: <code>W _ 1 _ 1,0,0,0 _ 3,2 _ 5,0,0,0 _ 3,3 _ 5,0,0 _ 0</code> triggers following sequence:</p> 																				

5.3.4 Error messages

Error messages always consist of 2 characters and a string limit.
The string limit can be defined in the master mode (section 4.5.1).

E, T

Transmission error

The terminal transmits a transmission error for errors in the received bit sequence, e.g. parity error, missing stop bit.

E, S

Syntax error

The terminal transmits a syntax error when it cannot process the received characters, e.g. command not present.

E, L

Logic error

The terminal transmits a logic error, when a command cannot be executed, e.g. when an attempt is made to write an non-writable application block.

5.4 Profibus-DP – communication with a PLC

5.4.1 Overview

The Profibus-DP-ID7sx is designed for operation as a slave on the Profibus-DP. This provides the following possibilities with a master PLC also connected to the Profibus-DP:

- Access to the weight values of the weighing platform connected to the weighing terminal
- Operation of the weighing platforms connected to the weighing terminal (zero-set, taring, setting specified tare values, etc.)
- Triggering key presses, transmitting data strings or display of texts

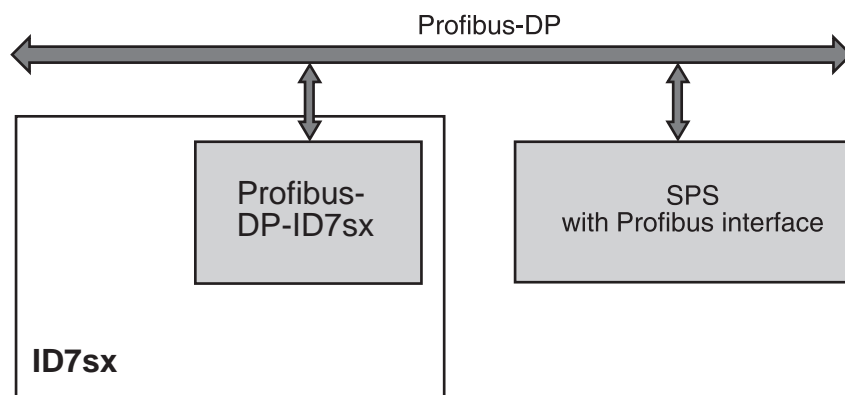

5.4.2 Data formats

All user data are transmitted in a compressed, up to 4-word long format.

Write table Format for transmitting user data from the PLC to the Profibus-DP-ID7sx.

Read table Format for the transmission of user data from Profibus-DP-ID7sx to the PLC.

Structure of the write and read table

The write and read table are similarly structured and contain the following sections:

- Value (16-bit integer or 32-bit floating point) for the transmission of weight values, application block numbers, etc.
- Commands or the corresponding responses with a total of 16 bits
- Control of 8 digital I/Os

5.4.3 Handshake

As certain commands can not always be executed immediately by the scale, e.g. taring with a restless weighing platform, 3 handshake bits of the PLC allow clear monitoring of the success of its commands:

1. The PLC starts a command by setting the corresponding command bit and also toggles COMMAND VALID in the write table. All other command bits are 0.
2. The weighing terminal responds with the current data of the read table. If it was possible to completely process the command, the COMMAND EXECUTED bit is toggled. Otherwise COMMAND EXECUTED remains unchanged.
3. The PLC recognises whether it can transmit the next command or must repeat the last one from COMMAND EXECUTED and transmits the write table to the weighing terminal.
4. The weighing terminal recognises from the status change of the COMMAND VALID bit that it should carry out the next command. In addition, the weighing terminal also detects whether the last command has been executed or is still running. If the PLC attempts to start new commands before the previous one has been confirmed by the weighing terminal with a status change of COMMAND VALID, the weighing terminal ignores this new command.

5.4.4 Commands and responses

All commands available to the PLC and the corresponding responses are shown in the following two tables.

Data direction PLC -> ID7sx Write table

Data direction ID7sx -> PLC Read table

Write table

16-Bit Integer 2 Words	Word 0			Word 1		
16-Bit Integer 4 Words	Word 0			Word 1	Word 2	Word 3
32-Bit Floating Point		Word 0	Word 1	Word 2	Word 3	
Bit	Value 16-Bit	Value 32-Bit Floating Point IEEE-754		Command	16 Digital I/O	AB data
0		Sign		Command valid Toggle-bit for all commands		
1		Exponent	Mantissa	Bits 1/2/3: Selection of read-table value, read/write AB 0/0/0 = Display 1/0/0 = Net 0/0/1 = Key No. 1/0/1 = Read AB 0/1/0 = Gross 1/1/0 = Tare 0/1/1 = Write AB 1/1/1 = Not in use	Setting of ID7sx outputs or Displaying or evaluating inputs of external I/O module	Data for writing an application block Tolerance specifica- tions are handled in % if the sign is set to 1.
2						
3						
4				Bits 4/5/6: Selection of write-table value 0/0/0 = Empty 1/0/0 = Tare specification 0/0/1 = Setpoint 1 1/0/1 = Setpoint 2 0/1/0 = Key No. 1/1/0 = Fixed Text No. 0/1/1 = Setpoint 3 1/1/1 = Setpoint 4		
5						
6						
7						
8				Taring		
9				Delete tare		
10				Set to zero		
11				ENTER key		
12				Input mode		
13				Switch keyboard on/off		
14				Reserved		
15	Sign			Bits 14/15: Selection of weighing platform 0/0 = None 1/0 = Scale 1 0/1 = Scale 2 1/1 = Scale 3		Sign

Read table

16-Bit Integer 2 words		Word 0		Word 1					
16-Bit Integer 4 words		Word 0		Word 1		Word 2	Word 3		
32-Bit Floating Point		Word 0	Word 1	Word 2		Word 3			
Bit	Value 16-Bit	Value 32-Bit Floating Point IEEE-754		Command			16 Digital I/O	Not in Use	
0		Sign		Command executed Toggle-bit for all commands			Showing or reading of ID7sx inputs or Displaying or setting outputs of external I/O module		
1		Exponent		Mantissa	Error command				
2					Movement				
3					Net				
4					Error scale (overload/underload...)				
5					Key(s) was/were pressed				
6					Input mode active				
7					Setpoint 1 reached				
8					Setpoint 2 reached				
9		Mantissa		Mantissa	Setpoint 3 reached				
10					Setpoint 4 reached				
11					1 = keyboard blocked, 0 = keyboard unblocked				
12					Reserved				
13					Reserved				
14					Bits 14/15: Current weighing platform				
15	Sign			0/0 = None 1/0 = Scale 1 0/1 = Scale 2 1/1 = Scale 3					

Notes on commands

If the command requires parameters, they will be transmitted either as an integer value or as a floating point value depending on the operating mode set.

Exception: The commands READ/WRITE APPLICATION BLOCK and PRESS KEY always expect integer values as parameters.

Read commands

- The read commands Display value, Net, Gross, Tare, Key and Application block overwrite the cyclically transmitted display values with the required data. The data are transmitted as 16-bit integers or 32-bit floating points. As soon as the COMMAND EXECUTED bit is toggled, these values must be evaluated immediately by the PLC, as in the next cycle the value in the read table is overwritten again with the current weight value.
- The response to the READ KEY NUMBER command (write table bits 1/2/3 = 0/0/1) is transmitted in the Word 0 (16-bit integer) or in Word 1 (32-bit floating point). The low byte contains the keyboard code, the high byte the function key code. The ID7 can store a maximum of 10 keys for being called via the READ KEY NUMBER command. If they are not called, the oldest key actuations are overwritten.
After reading out the last stored key, the KEY WAS PRESSED bit is reset. The key memory is cleared after the device is switched on and after the mastermode is exited.

Reading and writing application blocks

- When writing an application block, the desired data are simultaneously transferred with Word 3. For this reason, writing application blocks is only possible in 16-bit integer/4-word mode.
- Only application blocks with the formats "numeric" or "weight value" can be read or written. When writing, certain tolerance (sub-)blocks (e.g. with DeltaTrac) can be intentionally written with the format "percent" by setting the sign to "1".
- If a non-existent block or an alphanumeric block is selected, the ID7 responds with ERROR COMMAND.
The requested data are supplied in the 16-bit integer mode in the same format as the weight value, and in the 32-bit floating point mode floating point values are always transmitted.

The **application block number** in the write table must be entered as a value (Word 0 in 16-bit integer mode, Word 1 in 32-bit floating point mode) in the following format for the READ APPLICATION BLOCK and WRITE APPLICATION BLOCK commands:

"Basic" application block

	Sub-block no.				Exp.		Application block number									
	15	14	13	12	11	10	9	8	7	6	5	4	3	2	1	0
Example	S	S	S	S	E	E	A	A	A	A	A	A	A	A	A	A
AB 10	0	0	0	0	0	0	0	0	0	0	0	0	1	0	1	0
AB 20, sub-block 2	0	0	1	0	0	0	0	0	0	0	1	0	1	0	0	0

Expanded application block

Condition

One or more expanded application blocks are selected in the master mode.

Example

Application block 21 is selected as the 1st expanded application block, application block 46 is selected as the 2nd expanded application block.

	Sub-block no.				Exp.		Index of the expanded AB										
	Bit	15	14	13	12	11	10	9	8	7	6	5	4	3	2	1	0
Example	S	S	S	S	E	E	A	A	A	A	A	A	A	A	A	A	A
AB 21_007	0	0	0	0	0	1	0	0	0	0	0	0	0	0	1	1	1
AB 46_005, SB 1	0	0	0	1	1	0	0	0	0	0	0	0	0	0	1	0	1

Input of tolerances in %

If the sign (bit 15) in Word 3 is set to 1, tolerance specifications can be written accurately down to one decimal place in %.

This rule applies in the same way for Word 0 (16-bit integer) and Word 1 (32-bit floating point) when reading.

Example	Decimal	Binary															
		15	14	13	12	11	10	9	8	7	6	5	4	3	2	1	0
100.0 %	-1000	1	0	0	0	0	0	1	1	1	1	1	0	1	0	0	0
1 %	-10	1	0	0	1	1	0	0	0	0	0	0	0	1	0	1	0
0.1 %	-1	1	0	0	0	0	0	0	0	0	0	0	0	0	0	0	1

Write commands

- The write command PRESS KEY requires the low byte keyboard code and the high byte function key code as parameters.
- The function key code is based on the active function keys and must be correctly specified for each PRESS KEY command. A function key change can also automatically be forced by changing the function key code, e. g. from REF 10 (3301 hex) to X10 (0004 hex).
- The setpoints loaded via the WRITE SETPOINT X commands (e. g. Setpoint 1: write table bits 4/5/6 = 0/0/1) are deleted after switch-on and each time the mastermode is run. The Tolerance parameter in the setpoint modes Checking and Filling must be specified in the 16-bit integer mode with 2 decimal places, e.g. 1025 for 10.25 %.

Keyboard codes

Key	Code – Dec	Code – Hex	Key	Code – Dec	Code – Hex
Function key F1	1	01	Set to zero	14	0E
Function key F2	2	02	Taring	15	0F
Function key F3	3	03	Tare specification	16	10
Function key F4	4	04	Enter	17	11
Function key F5	5	05	Clear	18	12
Function key F6	6	06	ON/OFF	20	14
CODE A	7	07	+/-	31	1F
CODE B	8	08	. (Decimal)	46	2E
CODE C	9	09	Number key 0	48	30
CODE D	10	0A	Number key 1	49	31
Function change	11	0B	
Info	12	0C	Number key 9	57	39
Scale	13	0D			

Function key codes

Function key	Code – Dec	Code – Hex
Standard keys of ID7sx-Base	00	00
Extended tare keys of ID7sx-Base	02	02
Standard keys of Pac	51	33
Extended keys of Pac *	52	34
etc. *

* Only when the Pac is equipped with more than one function key page, i.e. more than 6 function keys.

Digital I/Os

The operating mode of a module 8 I/O-ID7sx installed on the ID7sx is dependent on the parameters CONTROL INPUTS, CONTROL OUTPUTS.

	Outputs	Inputs
No I/Os on ID7sx	The ID7sx controls external outputs via the read table.	The ID7sx reads external inputs from the write table and executes predefined actions.
I/Os on ID7sx, inputs and outputs configured to CONTROL INTERNAL	The ID7sx controls internal outputs and displays these in the read table.	The ID7sx reads internal inputs and executes predefined actions; the PLC has no access.
I/Os on ID7sx, inputs and outputs configured to CONTROL EXTERNAL	The PLC controls the outputs of the ID7sx via the write table.	The ID7sx reads internal inputs and displays these in the read table.

5.4.5 Messages in display

The following messages may appear briefly in the display:

Message	Meaning
PROFIBUS NOT ACTIVE!	<ul style="list-style-type: none"> Initialisation processes are still running on Profibus-DP. The ID7sx is not yet connected to the Profibus-DP.
PROFIBUS ACTIVE	<ul style="list-style-type: none"> Readiness restored, e.g. after switch-on, exiting mastermode or following a bus interruption.
PROFIBUS – ERROR BCC RX PROFIBUS – ERROR BCC TX	<ul style="list-style-type: none"> ID7sx or field bus module have detected a BCC error.
PROFIBUS – ERROR DATA RX PROFIBUS – ERROR DATA TX	<ul style="list-style-type: none"> Communication error ID7sx <-> Field bus module: e.g. not ETX, Uart error, etc.
PROFIBUS – TIMEOUT ID7	<ul style="list-style-type: none"> Communication error ID7sx <-> Field bus module: The ID7sx does not respond within the defined time.
PROFIBUS – ERROR CONF.	<ul style="list-style-type: none"> The field bus module has not received the configuration data properly.

5.4.6 GSD file

The GSD file required for communication with the Profibus-DP-ID7sx is available from METTLER TOLEDO Service or can be downloaded from the Profibus GSD Library at <http://www.profibus.com>.

5.4.7 Status LEDs on the Profibus-DP-ID7sx module

The 4 diagnosis LEDs on the Profibus-DP-ID7sx module show the following status:

LED	Status	Meaning
green	switched on	<ul style="list-style-type: none"> DP data cycles active
	switched off	<ul style="list-style-type: none"> DP data cycles inactive (DP connection cable not plugged or data cycles not started by the DP master)
yellow	blinking very fast	<ul style="list-style-type: none"> Bootloader active (after every switch on for approx. 2 seconds)
	switched off, short flash impulses every second	<ul style="list-style-type: none"> UART data exchange to ID7sx active, Profibus active
	switched on, short off impulses every second	<ul style="list-style-type: none"> UART data exchange to ID7sx faulty or not active, Profibus active
	switched off, short flash impulses every 3 seconds	<ul style="list-style-type: none"> serial data exchange to ID7sx active, Profibus inactive
	switched on, short off impulses every 3 seconds	<ul style="list-style-type: none"> serial data exchange to ID7sx faulty or not active, Profibus inactive

6 Application blocks

Application blocks are internal information memories in which weighing data, calculated quantities, configuration data or character sequences entered with the keypad are stored. The content of the application blocks can be read out or written to with a computer.

When the GA46 printer is connected via the PSU power supply unit in the safe area, the assignment of the application blocks can be printed out, see operating instructions for the GA46 printer.

6.1 Syntax and formats

The syntax and formats are dependent on the command set selected in the dialog mode, see page 40.

6.1.1 Read application block

Read

A | R | No.
A | R | _ | No.

MMR command set

SICS command set

The weighing terminal receives the command from the computer to read out the content of the "No." application block. Possible formats for "No." are:

xxx Entire application block
xxx.zz Sub-block of an application block
xxx_yyy Read-only memory
xxx_yyy.zz Sub-block of a read-only memory

This read command is **not** contained in the following description of the application blocks.

Response

A | B | _ | Information
A | R | _ | A | _ | Information

MMR command set

SICS command set

As a response the weighing terminal transmits the content of the "No." application block to the computer.

This response is contained in the following description of the application blocks in the MMR version.

Example

Command MMR
Command SICS

A | R | 0 | 2 | 1 | _ | 0 | 0 | 1
A | R | _ | 0 | 2 | 1 | _ | 0 | 0 | 1

Read out tare memory 1.

Response MMR
Response SICS

A | B | _ | _ | _ | _ | _ | _ | 1 | 0 | . | 5 | _ | k | g | _
A | R | _ | A | _ | _ | _ | _ | _ | 1 | 0 | . | 5 | _ | k | g | _

6.1.3 Data formats

- In the following description of the application blocks the following data formats are used:

<u>Weight value</u>	10 digits with sign and decimal point, right-justified (with preceding blank space)
<u>Unit</u>	3 characters, left-justified (with following blank spaces)
<u>Number_n</u>	Number, n digits, right-justified (with preceding blank spaces)
<u>Text_n</u>	maximum of n characters If the SICS command set is used, "Text" must always be placed in inverted commas.

- Conclude commands and responses with the string frame $C_R L_F$ (ASCII characters $C_R = 0D$ hex/13 deci, $L_F = 0A$ hex/10 deci). The string frame is **not** contained in the following description.

6.1.4 Read and write application blocks with the SICS command set

In the following description, the application blocks are shown in the syntax for the MMR command set. When used with the SICS command set, please observe the following SICS conventions, also see sections 6.1.1 to 6.1.3 :

- A blank space must be entered between AR or AW and the application block number: E. g. `A R _ _ No.`
- The command identification is repeated in the response and a blank space and the character A added:

`A R _ _ A _ Information` application block transmitted and
`A W _ _ A` application block written.

- Texts entered or transmitted are always in inverted commas.

Example Read application block for CODE A

Command: `A R _ _ 0 9 4`

Response: `A R _ _ A _ "Article"`

Write application block for CODE A

Command: `A W _ _ 0 9 4 _ "Article"`

Response: `A W _ _ A`

No.	Content	Format
020	Current DeltaTrac	Response: <input type="text" value="A,B _ Target weight (weight value) _ Unit _ _"/> <input type="text" value="Tolerance value (number_2) _ % _ _"/> Write: <input type="text" value="A,W 0,2,0 _ Target weight (weight value) _ Unit \$ \$"/> <input type="text" value="Tolerance value (number_2) _ % _ _"/>
021_001 ... 021_999	Tare memory 1 ... 999	Response: <input type="text" value="A,B _ Weight value _ Unit"/> Write: <input type="text" value="A,W 0,x,x _ ,x,x,x _ Weight value _ Unit"/> Comment: xx_xxx = 21_001 ... 21_999
021 ... 045	Tare memory 1 ... 25	Response: <input type="text" value="A,B _ Weight value _ Unit"/> Write: <input type="text" value="A,W 0,x,x _ Weight value _ Unit"/> Comment: xx = 21 ... 45 The contents of the tare memories 1 ... 25 are identical to the contents of the tare memories 021_001 ... 021_025.
046_001 ... 046_999	DeltaTrac memory 1 ... 999	Response: <input type="text" value="A,B _ Target value (weight value) _ Unit _ _"/> <input type="text" value="Tolerance value (number_2) _ % _ _"/> Write: <input type="text" value="A,W 0,x,x _ ,x,x,x _ Target value (weight value)"/> <input type="text" value="_ Unit \$ \$ Tolerance value (number_2) _ % _ _"/> Comment: xx_xxx = 46_001 ... 46_999
046 ... 070	DeltaTrac memory 1 ... 25	Response: <input type="text" value="A,B _ Target value (weight value) _ Unit _ _"/> <input type="text" value="Tolerance value (number_2) _ % _ _"/> Write: <input type="text" value="A,W 0,x,x _ Target value (weight value) _ Unit \$ \$"/> <input type="text" value="Tolerance value (number_2) _ % _ _"/> Comment: xx = 46 ... 70 The contents of the DeltaTrac memories 1 ... 25 are identical to the contents of the DeltaTrac memories 046_001 ... 046_025.
071_001 ... 071_999	Text memory 1 ... 999	Response: <input type="text" value="A,B _ Text_20"/> Write: <input type="text" value="A,W 0,x,x _ ,x,x,x _ Text_20"/> Comment: xx = 71_001 ... 71_999
071 ... 090	Text memory 1 ... 20	Response: <input type="text" value="A,B _ Text_20"/> Write: <input type="text" value="A,W 0,x,x _ Text_20"/> Comment: xx = 71 ... 90 The contents of the text memories 1 ... 20 are identical to the contents of the text memories 071_001 ... 071_020.

No.	Content	Format
091	Barcode EAN 28, EAN 128	<p>Response: <input type="text" value="A B _ EAN 28 _ _ EAN 128 01 _ _ EAN 128 310 _ _"/> <input type="text" value="EAN 128 330"/></p> <p>EAN 28: <input type="text" value="2 8 Article Check digit Weight"/> Article: 4-digit article no. from memory Code A Check digit: 1-digit, calculated by ID7sx-Base for the weight Weight: 5-digit positive weight value with 3 decimal places between 00.000 kg - 99.999 kg</p> <p>EAN 128 01: <input type="text" value="0 1 Article"/> or <input type="text" value="0 1 Article Check digit"/> or <input type="text" value="0 1 0 Article Check digit"/> or <input type="text" value="0 1 0 Article"/> Article: Article no. from memory Code A, max. 14 digits Check digit: 1-digit, calculated by ID7sx-Base Length: total of max. 16 digits</p> <p>EAN 128 310: <input type="text" value="0 1 9 Article Check digit 3 1 0 x Weight"/> or <input type="text" value="0 1 9 Article 3 1 0 x Weight"/> Article: Article no. from memory Code A max. 12 or 13 digits Check digit: 1-digit calculated by ID7sx-Base x: 0 ... 6, decimal places of weight value Weight: 6-digit net weight value</p> <p>EAN 128 330: <input type="text" value="3 3 0 x Weight"/> x: 0 ... 6, decimal places of weight value Weight: 6-digit gross weight value</p>
092	Barcode EAN 29	<p>Response: <input type="text" value="A B _ 2 9 Article Check digit Weight"/> Comment: Article: 4-digit article no. from memory Code A Check digit: 1-digit no., calculated from ID7sx-Base for the weight Weight: 5-digit positive weight value with 3 places to right of point between 00.000 kg ... 99.999 kg</p>
093	Barcode EAN 29 A	<p>Response: <input type="text" value="A B _ 2 9 Article Weight"/> Comment: Article: 5-digit article no. from memory Code A Weight: 5-digit positive weight value with 3 places to right of point between 00.000 kg ... 99.999 kg</p>
094 ... 097	Identification data Code A ... Code D	<p>Response: <input type="text" value="A B _ Name (text_20) _ _ Identification (text_30)"/> Write: <input type="text" value="A W 0 x x _ Name (text_20) \$ \$ Identification (text_30)"/> Comment: xx = 94 ... 97</p>
098	Number of last Alibi entry	<p>Response: <input type="text" value="A B _ Number_6"/> Note: The data record number is output with leading zeros</p>

No.	Content	Format
601	Parameters for Scale 1	Response: <input type="text" value="A"/> <input type="text" value="B"/> <input type="text" value="Parameters for Scale 1"/> Note: For service information purposes the internal scale parameters can be read out/printed; the structure and content are scale-dependent
602	Parameters for Scale 2	Response: <input type="text" value="A"/> <input type="text" value="B"/> <input type="text" value="Parameters for Scale 2"/> Note: For service information purposes the internal scale parameters can be read out/printed; the structure and content are scale-dependent
603	Parameters for Scale 3	Response: <input type="text" value="A"/> <input type="text" value="B"/> <input type="text" value="Parameters for Scale 3"/> Note: For service information purposes the internal scale parameters can be read out/printed; the structure and content are scale-dependent

6.3 INTERFACE application blocks

Application blocks are reserved for the possible interface connections. These application blocks can only be read and written to when an interface is actually installed on the interface connection concerned.

6.3.1 Serial interfaces

No.	Content	Format
101	Description of application	Response: <code>A,B _ ID7sx Interfaces</code>
102	Program designation	Response: <code>A,B _ IKY7-0-0100</code>
103	Transmit buffer COM1	Response: <code>A,B _ Transmit buffer COM1</code> Write*: <code>A,W 1,0,3 _ Information</code>
104	Transmit buffer COM2	Response: <code>A,B _ Transmit buffer COM2</code> Write*: <code>A,W 1,0,4 _ Information</code>
201	Description of application	Response: <code>A,B _ ID7sx Interfaces</code>
202	Program designation	Response: <code>A,B _ IKY07-0-0100</code>
203	Transmit buffer COM3	Response: <code>A,B _ Transmit buffer COM3</code> Write*: <code>A,W 2,0,3 _ Information</code>
204	Transmit buffer COM4	Response: <code>A,B _ Transmit buffer COM4</code> Write*: <code>A,W 2,0,4 _ Information</code>
701	Description of application	Response: <code>A,B _ ID7sx Interfaces</code>
702	Program designation	Response: <code>A,B _ IKY07-0-0100</code>

* Comments on the transmit buffers

- The entered information is transmitted directly via the selected interface.
- A transmit buffer contains a maximum of 246 characters.

6.3.2 Digital inputs/outputs

The following application blocks are only available when interface 8 I/O-ID7sx is installed.

When the weighing terminal checks the outputs, the blocks concerned cannot be written to, and the `E, L` error message appears.

No.	Content	Format
706	Digital outputs 1	Response: <code>A, B, _ 8-place binary value *</code> Write: <code>A, W 7, 0, 6 _ 8-place binary value *</code>
707	Digital inputs 1	Response: <code>A, B, _ 8-place binary value *</code>
724	Set point 1	Response: <code>A, B, _ Set point (Text_2) _ _ _</code> <code>A, x, x, x, _ y, y, y, . z, z _ _ _</code> <code>Scale (Text_3) _ _ _</code> <code>Set point value (weight value) _ _ _</code> Write: <code>A, W 7, 2, x _ Set point type (Text_2) \$, \$</code> <code>A, x, x, x, _ y, y, y, . z, z \$, \$</code> <code>Scale (Text_3) \$, \$</code> <code>Set point value (weight value) \$, \$</code> Note: $x = 4$ Set point type: $F\uparrow, F\downarrow, D\uparrow, D\downarrow$ Scale: $W1, W2, W3, ALL$ \uparrow Dec 24 = Hex 14 \downarrow Dec 25 = Hex 15 $Axxx_yyy.zz$ Application block Example: <code>A, W 7, 2, 5 _ F, \uparrow \$, \$ A, 0, 1, 1 \$, \$ W, 1 \$, \$</code> <code>1, . 2, 0, 0, _ k, g</code> fixed ascending switching point for the current gross weight on scale 1 at 1.200 kg
725	Set point 2	Response: equal to 724 Write: equal to 724, $x = 5$
726	Set point 3	Response: equal to 724 Write: equal to 724, $x = 6$
727	Set point 4	Response: equal to 724 Write: equal to 724, $x = 7$

* 8-place binary value: Bit8, Bit7 ... Bit1
Bit8 = output/input 8 ... Bit1 = output/input 1

7 What to do if ...?

Error / Display	Possible causes	Remedy
Display is dark	<ul style="list-style-type: none"> • No mains voltage • Wrong cabling 	<ul style="list-style-type: none"> → Check power supply unit → Cabling according to control drawing
Underload	<ul style="list-style-type: none"> • Load plate not in place • Preload not applied • Weighing range dropped below 	<ul style="list-style-type: none"> → Apply load plate → Apply preload → Set zero
Overload	<ul style="list-style-type: none"> • Weighing range exceeded • Weighing platform locked 	<ul style="list-style-type: none"> → Relieve weighing platform → Release lock
Weight display unstable	<ul style="list-style-type: none"> • Agitated set-up location • Draft • Agitated weighing sample • Contact between load plate and/or weighing sample and surroundings • Power malfunction 	<ul style="list-style-type: none"> → Adjust vibration adapter → Avoid drafts → Weigh dynamically → Eliminate contact → Check mains
Wrong weight display	<ul style="list-style-type: none"> • Wrong setting to zero of weighing platform • Wrong tare weight • Contact between load plate and/or weighing sample and surroundings • Weighing platform tilted • Wrong weighing platform selected 	<ul style="list-style-type: none"> → Relieve weighing platform, set to zero and repeat weighing → Delete tare or enter right tare value → Eliminate contact → Level weighing platform → Select right weighing platform
PLUG IN	<ul style="list-style-type: none"> • Weighing platform cable not connected correctly • Scale module not installed 	<ul style="list-style-type: none"> → Connect weighing platform cable according to control drawing → Mount scale module correctly
WRONG CODE	<ul style="list-style-type: none"> • Wrong personal code 	<ul style="list-style-type: none"> → Enter right personal code
SCALE NO. ERROR	<ul style="list-style-type: none"> • Error in weighing cell 	<ul style="list-style-type: none"> → Repeat test → If the message appears again: contact METTLER TOLEDO Customer Service

Error / Display	Possible causes	Remedy
OUT OF RANGE	<ul style="list-style-type: none"> • Zero set range exceeded • Gross weight negative • Taring range exceeded • Entered value outside permissible range 	<ul style="list-style-type: none"> → Relieve weighing platform → Relieve weighing platform and set to zero → Relieve weighing platform and set to zero → Enter permissible value
NOT ALLOWED	<ul style="list-style-type: none"> • Wrong cycle time for dynamic weighing • Weighing platform does not exist • Print with negative weight value 	<ul style="list-style-type: none"> → Enter cycle time between 1 and 255 cycles → Connect weighing platform → Relieve weighing platform, set to zero and repeat weighing
NOT EXISTENT	<ul style="list-style-type: none"> • Recalled memory not assigned 	<ul style="list-style-type: none"> → Recall other memory
NO DATA TRANSFER	<ul style="list-style-type: none"> • Weighing platform does not transmit data to the terminal 	<ul style="list-style-type: none"> → Disconnect power supply unit from the mains and reconnect again → If the message appears again: contact METTLER TOLEDO Customer Service
INTERF. C X – BREAK	<ul style="list-style-type: none"> • Wrong cabling • Interface module C2, C3 not connected in the ID7sx-Base or defective • Interface card and/or RS/CL20mA module in the PSU power supply unit not connected or defective 	<ul style="list-style-type: none"> → Perform cabling according to control drawing → Insert or change interface module → Insert or change RS/CL20mA module
TRANSMIT BUFFER FULL	<ul style="list-style-type: none"> • No transmission • Too many key messages and baud rate too low 	<ul style="list-style-type: none"> → Check handshake → Increase baud rate
KEY BUFFER FULL	<ul style="list-style-type: none"> • Data string currently being edited contains too many blocks 	<ul style="list-style-type: none"> → Remove blocks from data string
ERROR BARCODE	<ul style="list-style-type: none"> • The specified application block contains no data • Wrong sub-block selected, e.g. sub-block 0 	<ul style="list-style-type: none"> → Select application block which contains data → Select permissible sub-block
NO BLOCK	<ul style="list-style-type: none"> • Entered application block does not exist 	<ul style="list-style-type: none"> → Enter different application block

Error / Display	Possible causes	Remedy
BUFFER IS FULL	<ul style="list-style-type: none">• Data string of transfer key contains more than 10 application blocks	→ Change configuration of transfer key
DISPLAY MODE	<ul style="list-style-type: none">• Weighing cell defective• 2 weighing platforms with same scale number connected	→ Contact METTLER TOLEDO Customer Service → Contact METTLER TOLEDO Customer Service

8 Technical data and accessories

8.1 Technical data

Terminal	
Display	<ul style="list-style-type: none"> • Backlit LC display, with graphics capabilities, 64 240 pixels, display field 39 x 132 mm • Cover of scratch-resistant, hardened, antireflection glass
Keypad	<ul style="list-style-type: none"> • Tactile-touch membrane keypad with acoustic acknowledgement • Scratch-resistant marking, 3-color • 4 keys A to D for identification data, 6 function keys with function change and info key, 4 scale function keys, numerical keypad • Alphanumeric input possible with function keys
Housing	<ul style="list-style-type: none"> • All nickel chromium steel DIN X5 CrNi 1810 • Weight: net 3.2 kg, without cables
Type of protection	<ul style="list-style-type: none"> • II 2G EEx ib IIC T4 -10 °C ... +40 °C • II 2D IP65 T55 °C
Protection type (IEC 529)	<ul style="list-style-type: none"> • Dust and water-tight as per IP65/68 • Resistant to high-pressure and steam jet cleaning as per IPX9K
Pollution degree	2
Installation category	II
Power supply connection	<ul style="list-style-type: none"> • via PSU/ID...-Ex power supply unit (in the safe area) • via PSUx/.. (in the hazardous area)
Ambient temperature	<ul style="list-style-type: none"> • operation: -10 °C – +40 °C for weighing platforms of certification class III 0 – +40 °C for weighing platforms of certification class II • storage -25 – + 60 °C
Relative humidity	20 – 80 %, non condensing
Weighing platform connection	<ul style="list-style-type: none"> • 1 IDNet connection standard for METTLER TOLEDO weighing platforms of the D...x, K...x series, Point Ex system solution and analog weighing platforms with AWU 3/6 or Point Ex • In the configuration with the PSU power supply unit 2 additional IDNet connections (IDNet-ID7sx) are possible
Serial interface connection	<ul style="list-style-type: none"> • 1 CL20mA connection standard • In the configuration with the PSU power supply unit max. 2 additional serial interface connections (CL20mA-ID7sx or RS232-ID7sx) possible, see guide for installers and control drawing ME-22006478

Weighing functions	
Tare compensation	At the press of a button or automatically, up to maximum load (subtractive)
Tare target value	<ul style="list-style-type: none"> • For single-range scales over entire weighing range (subtractive) • For multi-range scales depending on national calibration regulations • 999 stored tare memories, protected against power failure
Tare calculation	Tare addition, tare multiplication, sub-tare
Tare indicator	NET lights up with saved tare weight
DeltaTrac	<ul style="list-style-type: none"> • Analog display of dynamic measured values • With optical marks for target value and tolerances • 3 selectable applications • 999 DeltaTrac memories, protected against power failure
Setting to zero	Automatic or manual
Gross changeover	Display of weight value can be changed over to gross weight at press of a button
Unit changeover	Unit can be changed over to weight units kg, g, mg, lb, oz, ozt, dwt in dependence on national calibration regulations at press of a button
Dynamic weighing	<ul style="list-style-type: none"> • Cycle time adjustable from 1 – 255 cycles • Automatic printout selectable
Stabilization detector	4-step, with motion indicator
Weighing process adapter	3-step adjustment to weighing sample
Vibration adapter	3-step adjustment to ambient conditions
Identification data	<ul style="list-style-type: none"> • 4 memories for 20 alphanumeric characters, can be recalled with keys A to D • Each memory can be assigned a fixed name which can be written in the marking field next to the corresponding key • 999 memories for frequently used identification data
Info function	Displays of current weighing data, identification data and memories at the press of a button
Date and time	<ul style="list-style-type: none"> • For printout or output via the data interface • Quartz-controlled, 12 or 24-hour display, automatic calendar function, Europe or US format, protected against power failures

Profibus DP-ID7sx	
Housing	aluminium, DIN locking foot
Dimensions	42 mm x 106 mm x 115 mm (W x H x D)
Weight	2,400 g
Protection type	IP20
Supply	24 V DC +/- 20 %
Current consumption	100 mA (at 24 V DC)
CPU core	80C52, 32 K RAM, 128 K flash
Displays	2 status LEDs
UART interface	RS232
UART buffer	max. 15 KB
Temperature range	0 – 50 °C
Max. humidity	90 %, non-condensing
Profibus	DP connection, 9-pin Sub-D
Electrical isolation	DP interface and 24 V DC
Baud rate	up to 12 Mbit/s
Node address	adjustable to between 0 and 126 in the master mode Factory setting: 126
Data width	2/4 IN and 2/4 OUT words, consistent for 2 words at operating mode 16-bit integer or for 4 words at operating mode 32-bit floating point
Status indication	2 LEDs

8.2 Accessories

Applications		Order No.
DataPac-ID7sx	Basic functions, data communication	22 008 442
DosPac-ID7sx	Basic functions, dispensing, filling	22 008 441
FormPac-XP-ID7sx	Basic functions, formulation, dispensing, based upon database, incl. PC software FormTool-XP	22 008 440

Weighing platform connections		Order No.
IDNet-ID7sx	<ul style="list-style-type: none"> • Connection for a weighing platform • Max. of 2 additional connections possible 	22 008 443
Point Ex-ID7sx	<ul style="list-style-type: none"> • Connection for an analog weighing platform • Max. of 2 additional connections possible 	22 008 443
Active CL/IDNet-ID7sx	<ul style="list-style-type: none"> • Connection for a weighing platform • Connection of a second ID7sx for use as a second display 	22 008 443

Serial data interfaces		Order No.
CL20mA-ID7sx	CL 20 mA interface, for installation in ID7sx	22 008 444
RS232-ID7sx	RS232 interface, for installation in ID7sx	22 008 445

Digital inputs/outputs		Order No.
8 I/O-ID7sx	8 digital inputs, 8 digital outputs	22 008 446

Network connection		Order No.
Profibus-DP-ID7sx	Field bus module: Connection via PSU/ID..Ex	22 008 649

Memory module		Order No.
Memory-ID7sx	<ul style="list-style-type: none"> • Paperless archiving of certification-relevant weighing data • Fail-safe storage of configuration data 	22 008 447

Barcode reader		Order No.
Barcode kit ID7sx	barcode scanner (II2G EEx ib IIC T4; II2D T 70°C) complete with RS232 ID7sx and Viper-Ex (SW) slotcard	22 008 640

Other accessories		Order No.
ID7sx installation set	for cabinet installation	22 008 439
Wall bracket	Completely rust-proof	00 504 130
Floor stand	Completely rust-proof	00 504 132
Stand socket	Completely rust-proof	00 503 701
Bracket stand	Completely rust-proof	00 504 128

9 Appendix

9.1 ASCII table

hex	deci	ASCII US	hex	deci	ASCII US	hex	deci	ASCII US	hex	deci	ASCII US	hex	deci	ASCII US
00	0	NUL	34	52	4	68	104	h	9C	156	₤	D0	208	⌚
01	1	SOH	35	53	5	69	105	i	9D	157	¥	D1	209	⌚
02	2	STX	36	54	6	6A	106	j	9E	158	₹	D2	210	⌚
03	3	ETX	37	55	7	6B	107	k	9F	159	₱	D3	211	⌚
04	4	EOT	38	56	8	6C	108	l	A0	160	á	D4	212	⌚
05	5	ENQ	39	57	9	6D	109	m	A1	161	í	D5	213	⌚
06	6	ACK	3A	58	:	6E	110	n	A2	162	ó	D6	214	⌚
07	7	BEL	3B	59	;	6F	111	o	A3	163	ú	D7	215	⌚
08	8	BS	3C	60	<	70	112	p	A4	164	ñ	D8	216	⌚
09	9	HT	3D	61	=	71	113	q	A5	165	Ñ	D9	217	⌚
0A	10	LF	3E	62	>	72	114	r	A6	166	ª	DA	218	⌚
0B	11	VT	3F	63	?	73	115	s	A7	167	º	DB	219	■
0C	12	FF	40	64	@	74	116	t	A8	168	¿	DC	220	■
0D	13	CR	41	65	A	75	117	u	A9	169	ƒ	DD	221	■
0E	14	SO	42	66	B	76	118	v	AA	170	ƒ	DE	222	■
0F	15	SI	43	67	C	77	119	w	AB	171	½	DF	223	■
10	16	DLE	44	68	D	78	120	x	AC	172	¼	E0	224	α
11	17	DC1	45	69	E	79	121	y	AD	173	¼	E1	225	β
12	18	DC2	46	70	F	7A	122	z	AE	174	«	E2	226	Γ
13	19	DC3	47	71	G	7B	123	{	AF	175	»	E3	227	Π
14	20	DC4	48	72	H	7C	124		B0	176	⋯	E4	228	Σ
15	21	NAK	49	73	I	7D	125	}	B1	177	⋯	E5	229	σ
16	22	SYN	4A	74	J	7E	126	~	B2	178	⋯	E6	230	μ
17	23	ETB	4B	75	K	7F	127	⏏	B3	179		E7	231	τ
18	24	CAN	4C	76	L	80	128	reserved	B4	180		E8	232	φ
19	25	EM	4D	77	M	81	129	ü	B5	181		E9	233	Θ
1A	26	SUB	4E	78	N	82	130	é	B6	182		EA	234	Ω
1B	27	ESC	4F	79	O	83	131	â	B7	183		EB	235	ö
1C	28	FS	50	80	P	84	132	ä	B8	184		EC	236	ø
1D	29	GS	51	81	Q	85	133	à	B9	185		ED	237	∅
1E	30	RS	52	82	R	86	134	á	BA	186		EE	238	ε
1F	31	US	53	83	S	87	135	ç	BB	187		EF	239	∩
20	32	SP	54	84	T	88	136	ê	BC	188		FO	240	≡
21	33	!	55	85	U	89	137	è	BD	189		F1	241	±
22	34	"	56	86	V	8A	138	ë	BE	190		F2	242	≥
23	35	#	57	87	W	8B	139	ï	BF	191		F3	243	≤
24	36	\$	58	88	X	8C	140	î	C0	192		F4	244	∫
25	37	%	59	89	Y	8D	141	ì	C1	193		F5	245	∫
26	38	&	5A	90	Z	8E	142	Ä	C2	194		F6	246	÷
27	39	'	5B	91	[8F	143	Å	C3	195		F7	247	≈
28	40	(5C	92	\	90	144	É	C4	196		F8	248	°
29	41)	5D	93]	91	145	æ	C5	197		F9	249	•
2A	42	*	5E	94	^	92	146	Æ	C6	198		FA	250	·
2B	43	+	5F	95	~	93	147	ö	C7	199		FB	251	√
2C	44	,	60	96	`	94	148	ø	C8	200		FC	252	n
2D	45	-	61	97	a	95	149	ò	C9	201		FD	253	²
2E	46	.	62	98	b	96	150	û	CA	202		FE	254	.
2F	47	/	63	99	c	97	151	ù	CB	203		FF	255	.
30	48	0	64	100	d	98	152	ÿ	CC	204				
31	49	1	65	101	e	99	153	Û	CD	205				
32	50	2	66	102	f	9A	154	Ü	CE	206				
33	51	3	67	103	g	9B	155	ç	CF	207				

10 Index

A

Accessories 103
 Acoustic signal 58, 73
 Additional functions 12
 Additive tare function 17
 Alphanumeric
 identification 18
 Alphanumeric printout 58,
 75
 Application blocks 57, 73,
 74, 87
 Applications 4
 ASCII characters 51, 105
 Automatic continuous
 transmission 40
 Automatic taring 9, 36, 101
 Autozero 9, 36

B

Barcode 21, 38, 46, 58
 Basic functions 9
 Big Weight Display 5, 21,
 22, 32

C

Certified weighing
 platforms 6
 Change over weight unit 53,
 73, 101
 Check mode 32
 Checkweighing 13
 Classifying 13
 Cleaning 8
 Command format 63
 Command overview 52, 64
 Commissioning 6
 Communication 39
 Configuration printouts 42

D

Data formats 51, 63
 Date 32, 101
 DeltaTrac 12, 31, 55, 74,
 101
 DeltaTrac memory 14, 30
 DeltaTrac target values 14,
 55, 74
 Dialog mode 39, 51
 Digital inputs/outputs 95,
 103
 Display 5, 57, 67, 99
 Display Mode 98
 Display update 37
 Dynamic weighing 15, 33,
 101

E

Error messages 60, 77, 96

F

Filling 13
 Function keys 5, 12, 99

G

GA46 38
 Gross 16, 101

H

Housing 99

I

I/O test 47
 ID code 6, 18
 ID5 mode 33
 ID7 mode 33
 Identifications 18, 58, 101
 Interface CL20mA-ID7sx 38
 Interface connections 38, 99
 Interface description 51
 Interface type 38
 Interface8 I/O-ID7sx 38
 Introduction 3

K

Keypad 5, 99

L

Language 31

M

Master mode 26
 Memory 20
 Memory-ID7sx 23, 38
 METTLER TOLEDO continuous
 mode 41
 MMR command set 40, 51
 Multiplicative tare function 17

P

Personal code 32
 Print 20
 Print mode 39, 42
 Printout 58
 Profibus-DP 49

R

Recall information 19
 Representable
 characters 105
 Reset scale 37
 Reset terminal 34

Response format 63

Restart 37

RS... 38

S

Safety precautions 3
 Sandwich tare 17
 Second display 21
 Second unit 37
 Serial interfaces 51
 Set zero 9, 53, 67, 101
 SICS command set 40, 63
 Stability detector 36
 Status byte 61, 62
 String framing 40, 51, 63
 Switch keypad on/off 53, 73
 Switch over weighing
 platform 11

T

Tare 9, 54, 101
 Tare memory 10, 30
 Taring 70
 Technical data 99
 Terminal 99
 Test weighing platform 18
 Text memory 19, 30
 Time 32, 101
 Transfer data 20
 Transfer string 40
 Transmit buffer 94
 Transmit data record 56, 72
 Transmit weight value 55,
 66

U

Unit changeover 101

V

Vibration adapter 36, 101

W

Weighing 10
 Weighing functions 101
 Weighing platform
 connections 99, 103
 Weighing process
 adapter 36, 101
 What to do if ...? 96

nefton
Ζύγιση
Σήμανση
Συμμόρφωση

Νεύτων Τεχνολογίες ΑΒΕΕ
Γέρακα 113, Τ.Θ. 67934
15344 Γέρακας
Τηλ: 210 6654544
Fax: 210 6654545
marketing@nefton.gr
www.nefton.gr



22008168A

Subject to technical changes © Mettler-Toledo (Albstadt) GmbH 04/10 Printed in Germany 22008168A

Mettler-Toledo (Albstadt) GmbH

D-72458 Albstadt

Tel. ++49-7431-14 0, Fax ++49-7431-14 232

Internet: <http://www.mt.com>