

5.8GHz Microwave Motion SENSOR

HLFS 590 User manual

Congratulations on your purchase of our microwave motion sensor product. You have purchased a safe, dependable, and easy-to-install security sensor system. This product can be widely used in offices, underground garages, buildings, corridor, stoop, washroom, and so on.

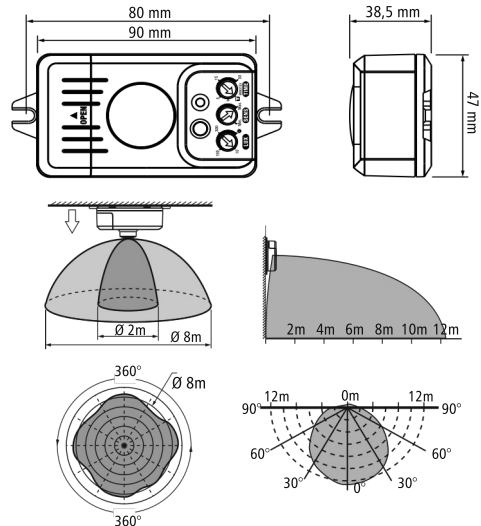
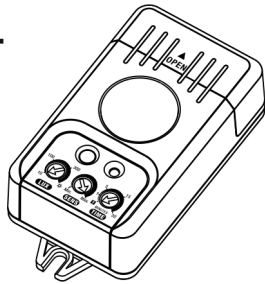

Carefully read the user manual thoroughly before using.

NOTICE

THIS PRODUCT MUST BE INSTALLED IN ACCORDANCE WITH ALL APPLICABLE INSTALLATION CODES.

1. IF YOU ARE NOT FAMILIAR WITH ELECTRICAL WIRING, IT IS RECOMMENDED THAT YOU SECURE THE SERVICES OF A WELL QUALIFIED ELECTRICIAN WHO CAN ASSURE THAT THIS INSTALLATION MEETS LOCAL, STATE, AND NATIONAL CODES.
2. BE SURE POWER IS TURNED OFF AT THE MAIN POWER PANEL OR FUSE BOX PRIOR TO INSTALLATION OR REPLACING SENSOR.
3. The sensor is for indoor use ONLY.
4. The sensor is suitable for dry locations.
5. A type C circuit breaker (6A/250VAC) according to EN60898-1 shall be installed in the fixed wiring for protection.
6. The electrical system and the method of connecting the sensor to the system must be in accordance with local, state, and national electric codes.
7. This sensor is to be connected to a $230 \pm 10\%$ volt, 50 or 60 Hz power source. Connecting to a different power source may create a hazard and will void the warranty.
8. Never use a lamp (loading) with a higher wattage than the stated maximum allowed on the sensor. Using a higher wattage loading may cause a fire hazard and/or damage to the unit.
9. Do not attempt to open the unit housing. There are no serviceable parts inside.

SPECIFICATIONS

RATING	230±10% VAC 50/60Hz
STANDBY POWER	approx. 0.6W
MICROWAVE FREQUENCY	5.8GHz ± 75MHz CW RADAR, ISM BAND, TRANSMITTER POWER < 0.2mW
USE LOCATIONS	INDOOR USE ONLY, CEILING or WALL MOUNTING
MOUNTING HEIGHT	FOR CEILING: 2~5m / FOR WALL: 1~2.5m
DETECTING ANGLE	FOR CEILING: 360deg / FOR WALL: 180deg
DETECTING DISTANCE	∅2~8m / FOR WALL: 3~12m
AMBIENT LIGHT CONTROL	10 Lux ~ ∞ (ADJUSTABLE)
TIME DELAY	1 ~ 30 MINUTES w/TEST MODE
MANUAL OVERRIDE	4 HOURS
SWITCH TYPE	RELAY (LOAD CAPACITY: 10A 277VAC)
OPERATING TEMPERATURE	0 ~ +60°C @ FULL LOAD; +70°C @ 60% LOAD
STORAGE TEMPERATURE	-20 ~ +80°C, 10~95% R H

MAXIMUM LOAD

INCANDESCENT	1000W
HALOGEN	500W
L.V. HALOGEN	200W
FLUORSCENT	400VA/cosφ=0.5 OR 160W/20uF Max.
ENERGY-SAVE LAMP	200W (CFL & PL)
LEDs LAMP	200W

HOW TO WIRE

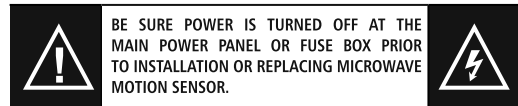

Please following the below steps to wiring.

STEP 1:

Open the cover according to the arrow marked before installing.

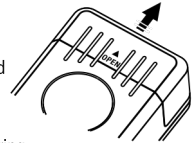

STEP 2:

Put the power wire into the corresponding wiring hole on the side of motion sensor(CL/L/N), then tighten with screwdriver.

Tips: make sure that the stripping length of wire must be between 3 to 5mm.

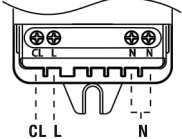

Philip screw driver

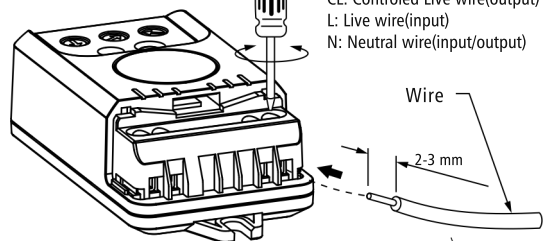

CL: Controlled Live wire(output)
L: Live wire(input)
N: Neutral wire(input/output)

STEP 3:

Put the cover back after wiring.

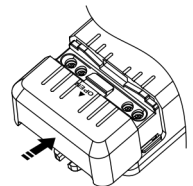

WIRING DIAGRAM

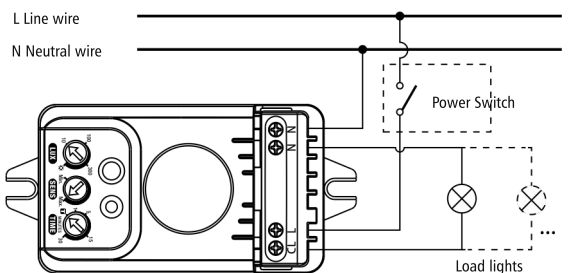

The microwave motion sensor can be installed in the ceiling lighting fixture, but...

1. Do NOT install the sensor in a closed space made of metal.
2. Avoid mount the sensor at wet and shaking place.
3. Be aware of the temperature inside lamp housing should be lower than +60°C.
4. It is recommended to mount the sensor on the material of plastic, wood or PVC instead of metal if the lamp is made of different materials.
5. Ensure the sensor is far away(at least 60mm) from the ballast, lamp hold or filament.

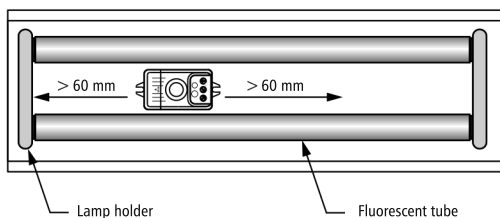
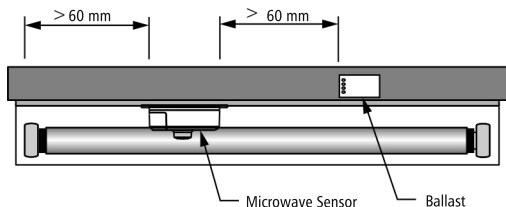
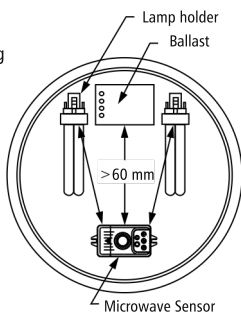

HOW TO SETTING

HFS-590C series have three VR knobs to control the connected electrical appliances, which can be automatically turn ON or turn OFF according to setting value.

1. Ambient illumination detector (Photodiode)
2. Indicator (Red LED)
3. **TIME** Time setting knob
4. **SENS** Sensitivity setting knob
5. **LUX** Ambient light setting knob

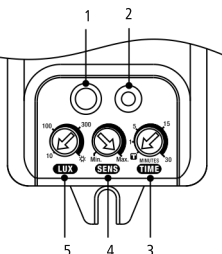

Sets how long the loading will stay on after motion is detected (between 1 to 30 minutes)

Turning the knob will change time duration. Every time motion is detected, the timer will restart and turn the loading off at the end of setting. The load will remain ON until the last movement is detected. (The **☐** mark is used for installation test)



Sets the sensitivity of the microwave motion sensor

Turning this knob counterclockwise will decrease the sensitivity and detecting range of motion sensor, clockwise will increase the sensitivity and detecting range.



Sets the values of ambient light

When the values which be detected by photodiode less than the setting's, the detector will become activity, otherwise it enter standby mode. Clockwise the knob to mark **☼**, the sensor detection will always be enabled.

SENSOR STATUS

Warm-up: (LED indicator - ON; Loading - ON)

This unit requires a warm-up of approx. 30 seconds after power is applied for the system's circuit to stabilize.

Test Mode: (LED indicator - ON; Loading - ON)

Counterclockwise rotate the **TIME** adjustment knob to **☐**, the sensor will enter the TEST mode, each time motion is detected, the load will be ON 2 seconds ONLY, then delay 2 seconds for next time detection.

Clockwise rotation the **TIME** adjustment knob to any position of 1~30, will exit the test mode.

Stand-by: (LED indicator - OFF; Loading - OFF)

In the non-test mode, if the sensors detect ambient light level is higher than the **LUX** adjustment knob settings, it will enter standby mode.

Automatic Mode:

(LED indicator - Fast flash twice each detection; Loading - Auto ON/OFF)

In the non-test mode, if the sensors detect ambient light level is less than the **LUX** adjustment knob settings, the auto motion detecting will be activated.

Manual Override:

(LED indicator - Interval 5 seconds flash 1 time; Loading - ON)

Flip the power switch (If applicable) OFF and then ON twice within 2 seconds, this will put the sensor into Manual Override status - which means the light will be ON and auto OFF after 4 hours, or turn OFF the sensor's power switch and then ON again within 2 seconds to place the sensor back to AUTOMATIC status.

FAQ

Q1: Does not function at all

- Make sure the power switch (if applicable) is ON and check the wiring is correct.
- Check that the circuit breaker, fuse, and main circuit breaker or main power switch are ON.
- Check that the loading (such as light bulb) is functional.
- The ambient light level is higher than settings, if necessary, may be appropriate to increase the set value of **LUX**.

Q2: The sensor light is always ON

- The setting of delay time is too long, if necessary, may be appropriate to reduce the set value of **TIME**.
- The sensor is in the Manual Override state, turn OFF the sensor's power switch and then ON again within 2 seconds to place the sensor back to AUTOMATIC status.
- The sensor be installed on movable and/or frequent vibrations of objects, please change the sensor's mounting location.
- If the sensor be installed in the fixture with fluorescent tube or CFL/PL lamp, try to appropriate to reduce the set value of **SENS**.

LIMITED LIFETIME WARRANTY

3 YEARS GUARANTEE. This product is warranted to be free from defects in material and workmanship for life of product. If a defect occurs, call your suppliers for instructions on how to have defective product repaired or replaced free of charge.

LIMITATIONS - This warranty only covers assembled sensor products and is not extended to other components, Lamp Bulb(s), or equipment used on the product. Warranty extends to original purchaser of product. Receipt or other approved proof of purchase required for warranty service. **NOT LIABLE FOR INCIDENTAL, INDIRECT, OR CONSEQUENTIAL DAMAGES.** Some states do not allow the exclusion or limitation of incidental or consequential damages, so the above limitation or exclusion may not apply to you. This warranty gives you specific legal rights, and you may also have other rights which vary from state to state.

NOT COVERED - Product failure not relating to faulty material or workmanship, corrosion of brass components, reimbursement for installation or unauthorized service.

TIPS:

1. Appropriate to increase the delay time, can effectively extending the life of the product.
2. The emission power of this microwave sensor is less than 0.2mW, only 1/5000 of the GSM mobile phone or electric stove, long-term use will NOT cause harm to human, animal or plant.

