

INSTALLATION, COMMISSIONING AND MAINTENANCE MANUAL

KU-M Series
KU-P Series
KU-B Series
KU-H Series

Publication: UPM-KU-R04-EN



***IT IS RECOMMENDED TO KEEP THIS
INSTRUCTION MANUAL IN THE
VICINITY OF THE UNIT AND WITHIN
REACH OF THE AUTHORIZED
PERSON RESPONSIBLE FOR
MAINTENANCE!***



Manufacture of Ventilation, Air-conditioning
and Hot Air Heating Equipment

Head : Talani 14, HR-10000 Zagreb, Hrvatska
Office and factory : Gradna 78E, HR-10430 Samobor
Phone: +385 1 / 6546-343
Fax: +385 1 / 6546 - 344

Email: proklima@proklima.hr
Internet: www.proklima.hr

TABLE OF CONTENTS

1	SAFETY, TRANSPORT, STORAGE	3	4.12 COMPRESSORS	28	
1.1	PREFACE, CAUTIONS AND WARNINGS	3	4.13 FAN UNITS	29	
1.2	SAFETY FEATURES	3	4.14 CONTROL SWITCH-BOXES AND AUTOMATIC CONTROL ELEMENTS	29	
1.3	APPLICATION	4	5	COMMISSIONING	30
1.4	DESIGN	4	5.1	CONTROL SWITCH-BOX	30
1.5	SERVICE SIDES	4	5.2	AUTOMATIC CONTROL ELEMENTS	31
1.6	TRANSPORTATION AND STORAGE	5	6	UNIT MAINTENANCE-GENERAL	32
1.7	UNIT PLACEMENT	6	6.1	RECOMMENDED INSPECTION AND MAINTENANCE INTERVALS	32
1.8	UNIT LOCATION	6	6.2	MAINTENANCE OF UNITS IN HYGIENIC DESIGN	33
1.9	ASSEMBLY	7	6.3	CHECKLIST FOR OPERATION AND MAINTENANCE OF AIR-HANDLING UNITS OF A HYGIENIC DESIGN (ACCORDING TO VDI 6022)	34
2	INSTALLATION OF UNIT COMPONENTS	12	7	MAINTENANCE OF UNIT COMPONENTS	38
2.1	CONNECTING THE UNIT TO AIR DUCTWORK	12	7.1	DAMPERS	38
2.2	CONNECTING OF COILS	13	7.2	FILTERS	38
2.3	CONNECTING SPRAY HUMIDIFIERS	16	7.3	TWIN-COIL HEAT EXCHANGERS	39
2.4	CONNECTING STEAM HUMIDIFIERS	17	7.4	ELECTRIC HEATERS	39
2.5	SIPHON MOUNTING	17	7.5	SPRAY HUMIDIFIERS	39
2.6	UNITS WITH BURNERS	18	7.6	STEAM HUMIDIFIERS	40
2.7	DAMPERS	19	7.7	PLATE HEAT EXCHANGERS	40
2.8	ELECTRIC-MOTOR DAMPER DRIVES	19	7.8	ROTARY WHEEL HEAT EXCHANGERS	41
3	ELECTRICAL INSTALLATIONS	20	7.9	UNITS WITH BURNERS	41
3.1	WIRING	20	7.10	COMPRESSORS	41
3.2	ELECTRIC MOTORS	20	7.11	FAN UNITS	42
3.3	ELECTRIC HEATERS	24	7.11.1	BELT TRANSMISSION	42
3.4	SPRAY AND STEAM HUMIDIFIERS	25	7.11.2	CHECKING, LUBRICATION AND REPLACEMENT OF BEARINGS	46
3.5	ROTARY WHEEL HEAT EXCHANGERS	25	7.11.3	MOTORS	46
3.6	CONTROL SWITCH-BOXES	25	7.11.4	PLUG-IN FANS	46
3.7	AUTOMATIC CONTROL ELEMENTS	25	7.12	CONTROL SWITCH-BOXES	49
4	PREPARATIONS FOR INITIAL COMMISSIONING	26	7.13	OTHER COMPONENTS OF THE UNIT	49
4.1	ELECTRIC SYSTEMS	26	8	HANDLING WITH  ATEX UNITS	50
4.2	DAMPERS	26	9	SWITCHING OFF AND LONG SHUTDOWN PERIODS	51
4.3	FILTERS	26	10	CHECK MEASUREMENTS	51
4.4	COILS – HEATERS AND COOLERS	26	11	INFORMATION	51
4.5	ELECTRIC HEATERS	27		DECLARATION OF CONFORMITY	52
4.6	SPRAY HUMIDIFIERS	27			
4.7	STEAM HUMIDIFIERS	27			
4.8	TWIN-COIL HEAT EXCHANGERS	27			
4.9	PLATE HEAT EXCHANGERS	28			
4.10	ROTARY WHEEL HEAT EXCHANGERS	28			
4.11	UNITS WITH BURNERS	28			

1 SAFETY, TRANSPORT, STORAGE

1.1 PREFACE, CAUTIONS AND WARNINGS

This booklet describes proper installation, operation and maintenance procedures for air handling units. By carefully reviewing the information within this manual and following the instructions, the risk of improper operation and/or component damage will be minimized. This manual is intended for use by authorised operating and service personnel, who should possess the appropriate training and skills to enable them to perform their tasks competently and safely.

Your personal safety and proper operation of unit depend upon the strict observance of following precautions and safety signs :



DANGER : Indicates imminently hazardous situation which, if not avoided, will result in death or serious injury.



WARNING : Indicates potentially hazardous situation which, if not avoided, will result in serious injury.



CAUTION : Indicates a potentially hazardous situation which, if not avoided, may result in minor or moderate injury. It may also be used to alert against unsafe practices.

NOTICE : Provides, highlight and clarify additional information, remark or suggestion.

1.2 SAFETY FEATUERES

NOTICE : This instruction manual is to be kept in the vicinity of the unit and within reach of the maintenance personnel.

To comply with EC Council Directives 98/37/EC Machinery Directive.

To be read in conjunction with relevant Product Documentation.

It is essential that before performing any task, the operative shall have read and understood this manual together with any other documents referenced.

The connecting and commissioning of the unit are to be carried out under conditions that are in conformity with relevant regulations, especially those valid in the field of electrical devices.

Installation, electrical connection and commissioning are only to be carried out by authorized personnel and in accordance with requirements and demands. Electrical connection according to the wiring diagram in the terminal box, markings on terminal blocks or on cable.

The main power supply must not be turned on before the unit has been connected to the safety system and grounded.

It is forbidden to carry out service and maintenance operations if the power supply is not disconnected.

It is forbidden to operate the unit if some parts of casings have been dismantled from individual components or sections.

The maintenance and service personnel must be adequately qualified and have valid work permits issued by the competent authority.

The service area must be equipped with all necessary protective equipment (emergency exits, first-aid-box, fire-extinguisher, etc.) to guarantee personal safety during maintenance operations.

1.3 APPLICATION

This installation and maintenance manual refers to air-handling units (hereinafter referred to as: units) of KU-M series (modular), KU-P series (ceiling-mounted), KU-B series (swimming-pool units) and KU-H series (hygienic) manufactured by PROKLIMA (hereinafter referred to as: the manufacturer). It contains basic data about the design, methods and rules of installation, preparation and starting up of the unit, including recommendations for a regular maintenance.

The units of KU-M, KU-P, KU-B and KU-H series are used as air treatment units in ventilation and air-conditioning systems of industrial, business, sports and other facilities. The size of the units is determined by the air volume flow rate ranging from 800 to 130,000 m³/h and unit components specified by the design. They enable mixing, filtering, heating, cooling, humidification or dehumidification of air, sound attenuation, heat recovery, etc.

1.4 DESIGN

The unit consists of one or more sections interconnected into a whole. Each section (except in case of double and ceiling-mounted units) is fixed on a base made of galvanized steel plates or steel profiles of a corresponding height.

For the purpose of reducing transmission of vibrations to the building structure rubber washers (supplied by the manufacturer) are placed under the base.

The unit casing of KU-M, KU-P and KU-B series is made of aluminium profiles and angle elements, including galvanized steel panels stuffed with inflammable mineral wool (non-combustibility class A1 according to DIN 4102, Part 4.) that provides adequate heat and acoustic insulation. Panels may be 15, 25 and 50 mm thick. External surfaces of panels, profiles and angle elements may be powder-coated in a standard colour or another RAL colour on request. On request or if required, panels may also be powder-coated on both sides or have the internal surface made of stainless steel plate (e.g. in case of units exposed to an aggressive medium).

The unit casing of KU-H series is made of galvanized and/or stainless steel panels stuffed with inflammable mineral wool (non-combustibility class A1 according to DIN 4102, Part 4.) that provides adequate heat and acoustic insulation. Panels may be 30 and 50 mm thick.

Inlet and terminal devices of the units are equipped with flexible connections for connecting to the air ductwork. The airflow is controlled by manually or electric-motor-driven dampers.

Units intended for outdoor installation are equipped with a protective roof and an elevated base. Connections for fresh air inlet and exhaust air discharge include air inlet/outlet hoods with a built-in protective net or fixed grill to prevent penetration of rain water into the unit. All elements are powder-coated for the protection against atmospheric influence.

1.5 SERVICE SIDES

The units are manufactured so that access may be provided on the left or on the right side, depending on the direction of airflow through the unit and the position of the service door, pipe connections, condensate drains, etc.

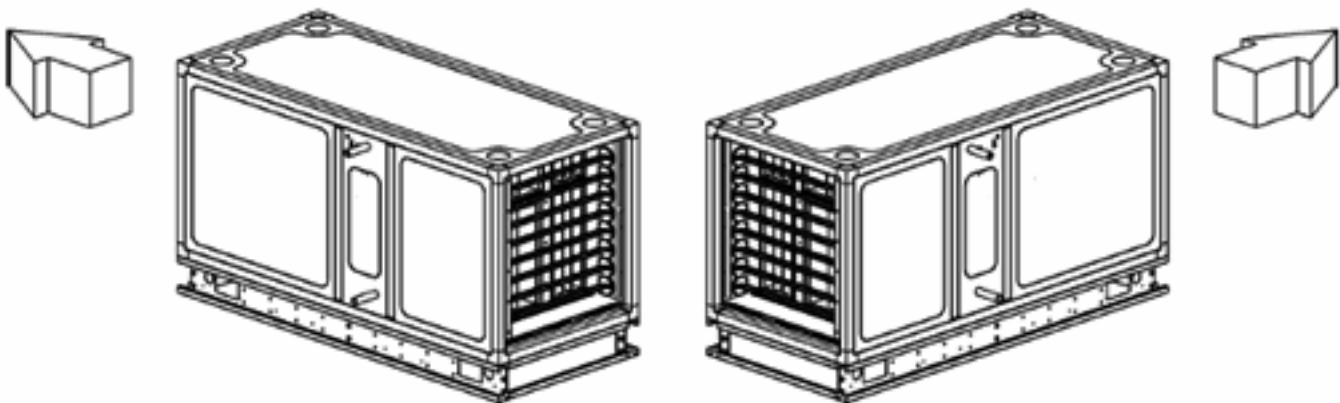

LEFT SIDE SERVICE (L)

RIGHT SIDE SERVICE (D)

With double and side-by-side unit designs the service side depends on the direction of airflow in the discharge unit.

With vertical designs the service side is determined by a special agreement or rather an isometric sketch.

NOTICE : This instruction manual is to be kept in the vicinity of the unit and within reach of the maintenance personnel.

1.6 TRANSPORTATION AND STORAGE

The units are supplied in separate sections or fully disassembled, if so requested. (This manual does not contain instructions or recommendations for installation of units supplied fully disassembled. In such a case please consult the manufacturer.). Each section is protected by foil. All unit sections contain an assembly plan and information about weights of individual sections. Immediately upon receipt of the unit it is necessary to check the packaging and accompanying documents.

Sections are to be unloaded from the vehicle and conveyed into the building by a forklift or a crane. In order to facilitate forklift handling and protect unit sections against damage, the sections without a base are placed on wooden pallets. In case that forklift forks are too short to catch a section, extensions of a corresponding length are to be applied (see the illustration).

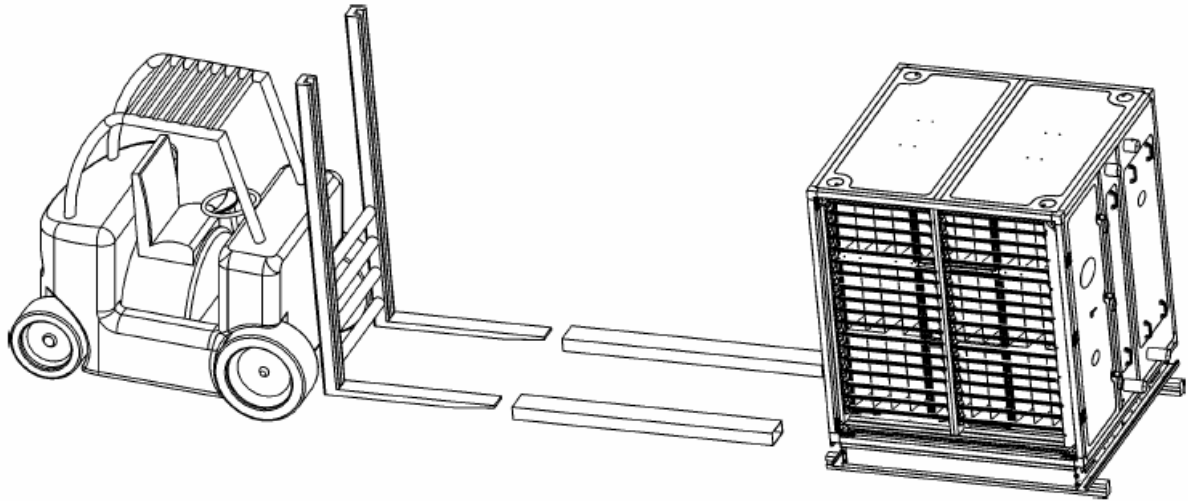

CAUTION :

Please do not overlap the unit vertically or horizontally. Do not stack for lifting or storage. Forklift operator should be qualified and have valid driving certificate.

The crane transfer is to be carried out by means of steel ropes of equal length and spreader bars wide enough to avoid damaging the unit casing (see the illustration). For crane transfer the lifting holes made in the unit base (as standard) or lifting brackets (fitted on a special request of the customer) are used.

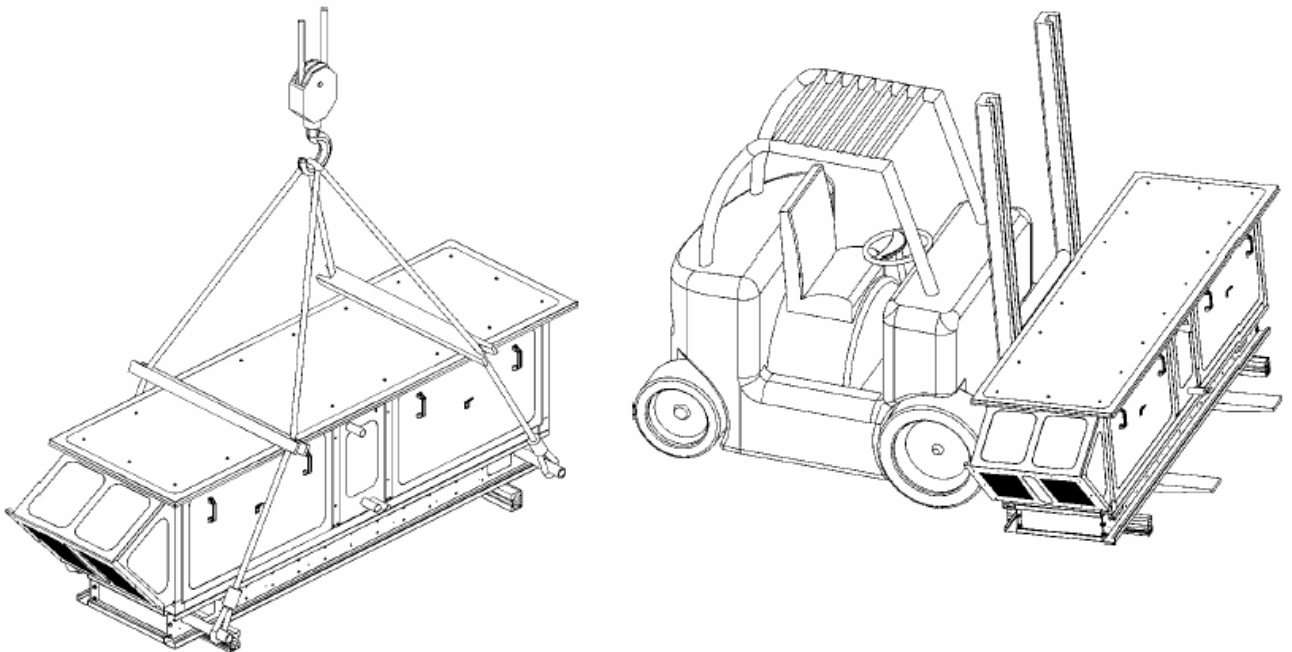

DANGER :

LIFTING OF UNIT NEAR PRESENT PEOPLE INCREASE THE DANGER OF FALLING THE UNIT CAUSING SEVERERE INJURY OR DEATH. PLEASE SECURE THE AREA FROM PERSONNEL ATTENDANCE OR TAKE OTHER NECESSARY PRECAUTIONS TO AVOID OR DECREASE THE RISK OF INJURY OR DEATH.

The units may only be transported in the fitting position and properly fastened so as to prevent them from shifting during transportation. The manufacturer's warranty does not cover any damage caused by inadequate transportation, inexpert unloading or inappropriate storage. All complaints about damage suffered are to be submitted to the forwarder or the warehouse manager.

The sections must not be stacked. All the sections supplied are to be stored in an area that meets the following requirements:

- the maximum permissible air humidity does not exceed 80% at a temperature of 20°C;
- the ambient temperature ranges between -20°C and +40°C;
- dust, aggressive gases or chemicals causing corrosion of unit components and casing must not come into contact with the unit.

In case of a lengthy storage the plastic foil used for packaging must be removed in order to prevent condensation. Units of the outdoor design may be stored in the open air, but must be protected by a moisture-proof cover. It is necessary to take all measures to prevent condensation and ensure natural ventilation under the cover.

1.7 UNIT PLACEMENT

The unit is to be placed on a concrete base plate or a specially fabricated and reasonably sturdy steel structure. The foundation or rather the steel structure must be aligned and levelled by a spirit-level to ensure that the unit leaning on the platform and rubber washers is resting over the entire width with no deformation. The fundament and the unit base height must facilitate free mounting of a corresponding siphon, drains, etc. When supplying spray humidifiers the unit must be installed in such a manner to ensure the alignment of top sides (surfaces) of all sections.

NOTICE : For determination of the minimal height of the base plate or steel structure please contact the manufacturer.

Examples of mounting the unit on a base plate or a steel structure:

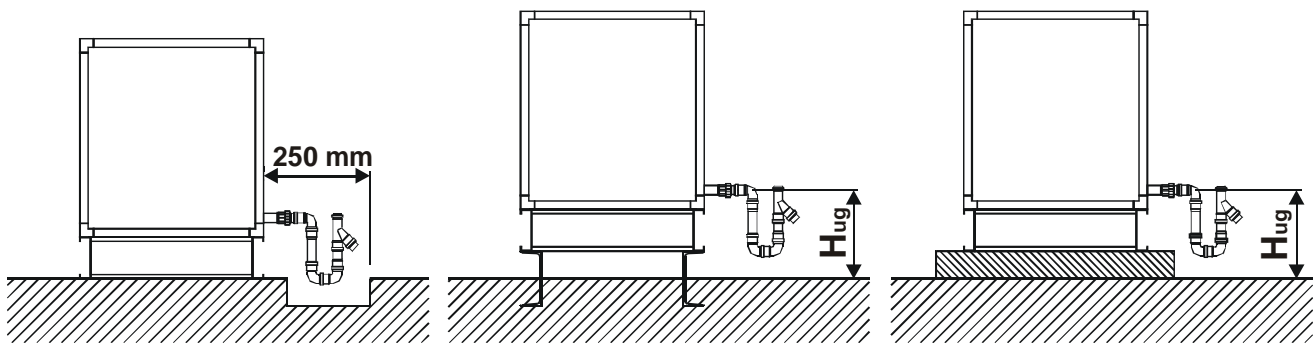

The recommended minimum distance between the siphon connection and the base Hug equals the height of the siphon mounted (see Chapter 2.5) increased by 2 widths of the siphon mounted ($2 \times \phi D$) and the height of the steel structure or the concrete base plate.

1.8 UNIT LOCATION

When placing the unit enough space should be left for connecting to the air duct system, to hot, cold and process water piping and electrical installations. Besides, the unit must be installed in such a way to facilitate a smooth operation and maintenance of all built-in sections and components. The minimum width of the free space on the access side must be as follows:

- for fan, filter and mixing unit $L = B$
- for heat exchangers (heaters, coolers) units with burners $L = B + 250$
- for rotating heat exchanger unit $Lo = Bo + 250$

where

- B means the unit width
- Bo means the rotating heat exchanger unit width

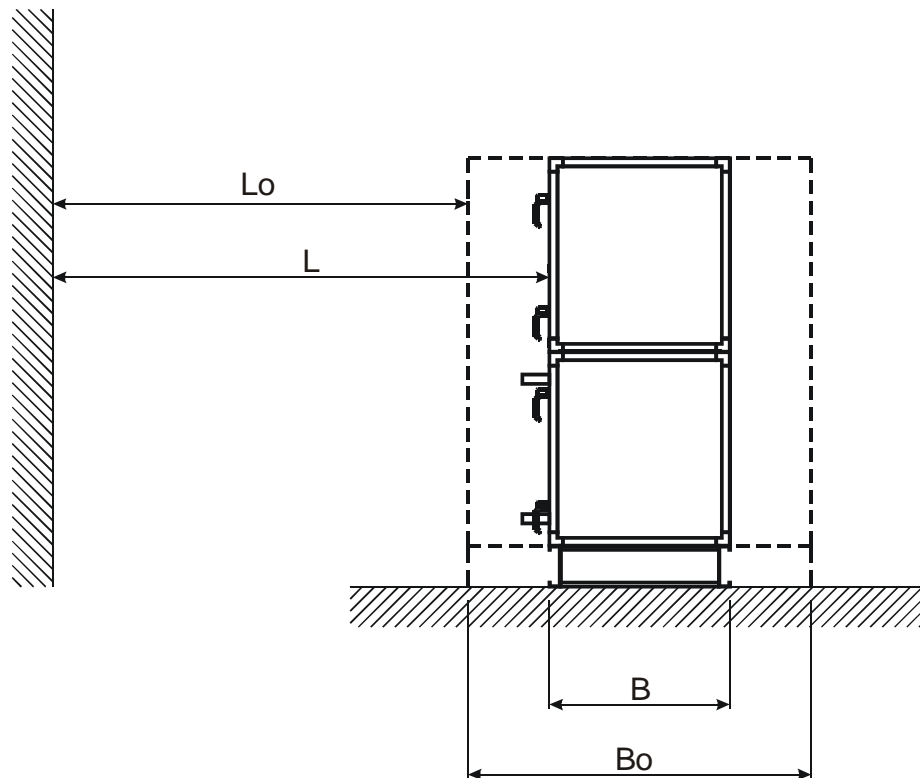

NOTICE : In case of a side-by-side unit design, free access space must be provided on both sides of the unit.

The installation of piping, equipment and support elements on the access side is only permitted in the way that enables a simple dismounting and mounting during maintenance and servicing.

1.9 ASSEMBLY

Before assembling unit sections into a whole it is necessary :

- to remove the protective foil from all sections;
- to remove all auxiliary brackets (if any) used to protect unit components during transportation;
- to put the unit down from the wooden pallet or wooden supports used during transportation;
- to remove all other suspension elements used for transportation and unloading operations;
- to mount dampers and flexible connections (if not mounted for reasons of transport);
- to place the unit sections in the location envisaged, following the instructions relating to the position of individual sections within the entire unit (applies to units supplied in several modules) according to the assembly plan affixed to each section.

Unit sections are to be assembled using the tools supplied in a box. The assembly kit may be found in one of the unit modules, usually in the fan unit module.

The unit sections may be assembled into a whole in several steps:

1.9.1 KU-M and KU-B Series

1.9.1.1 Sealing

If a unit is supplied in more than one component (section), one side of all joints of unit sections must be covered with sealing strip (see the illustration).

When assembling unit sections, size KU 1 – KU 6, the strip is to be placed on the aluminium profile longitudinally over the entire cross-section of the unit, as close as possible to the outer side of the profile.

When assembling unit sections, size KU 7 – KU 17, the strip is to be placed in two layers – one closer to the outer and another closer to the inner side of the aluminium profile.

KU 1 – KU 6

KU 7 - KU 17

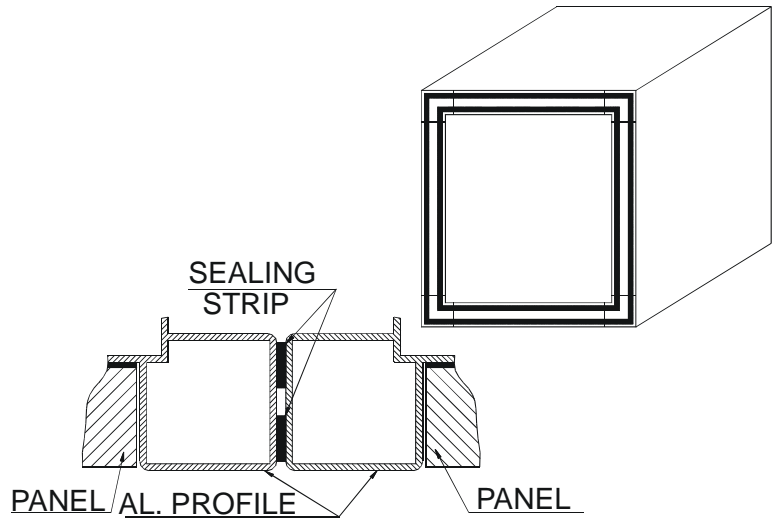
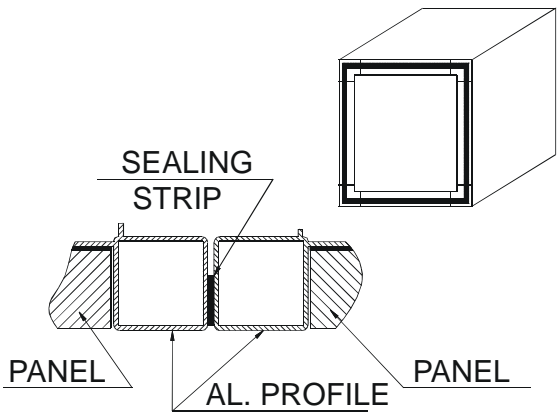

Način ljepljenja brtvene trake za spojeve sekcija uređaja

1.9.1.2 Unit positioning, shimming and levelling

Each unit section is to be placed in a corresponding location in the engine-room (according to the unit assembly plan) or any other location as may be specified by the design.

Rubber pads for sizes KU 1 – KU 8 (Fig. a) are to be placed underneath the base in all sections corners, and for sizes KU 9 – KU 17 in all section corners and in the middle of the section (Fig. b).

After the unit is shimmed by rubber pads, all sections must be levelled.

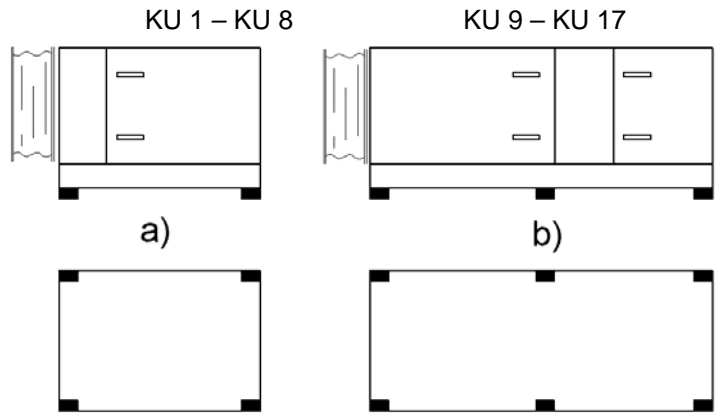

Method of shimming by rubber pads

1.9.1.3 Assembly of unit sections

Unit sections are to be assembled as illustrated below :

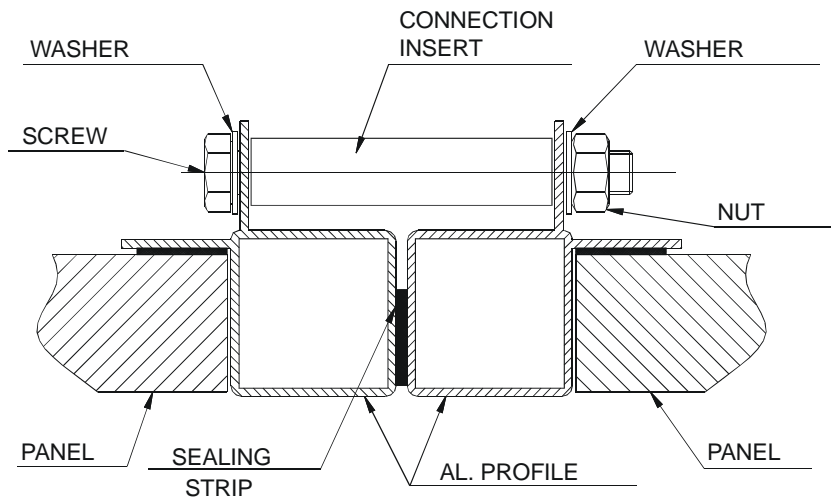

UNIT OUTSIDE

Assembly of sections in standard and outdoor design

Two to three bolted joints in each point where sections are assembled must have a star-like washer.

1.9.1.4 Assembly of the roof (for outdoor design only)

The roofing steel plate joints must be protected by a joining profile. The joining profile is to be fixed on the roofing steel plate joint and holes for corresponding rivets or bolts (supplied by the installing contractor) are to be made at a distance of approximately 400 mm. For each roof joint one joining profile is to be supplied.

Finally, the joint of roofing steel plates and the joining profile must be fastened by a riveted or bolted joint (see the illustration).

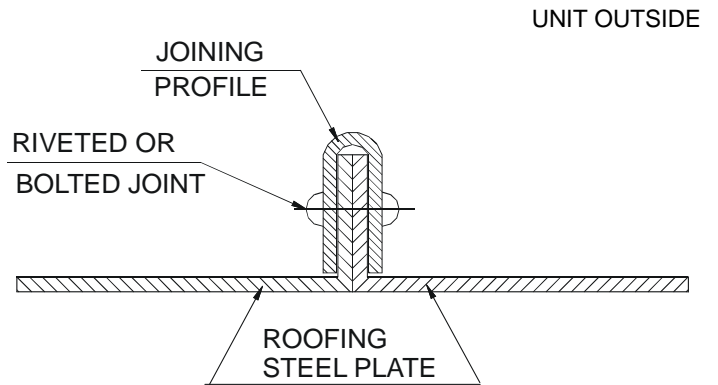

Joining roofing steel plates of individual sections

1.9.2 KU-P Series

1.9.2.1 Sealing

If a unit is supplied in more than one component (section), one side of all joints of individual unit sections must be covered with a sealing strip (see the illustration).

The strip is to be applied to one side of the joint, to the aluminium profile longitudinally over the entire cross-section of the unit, as close as possible to the outer side of the profile.

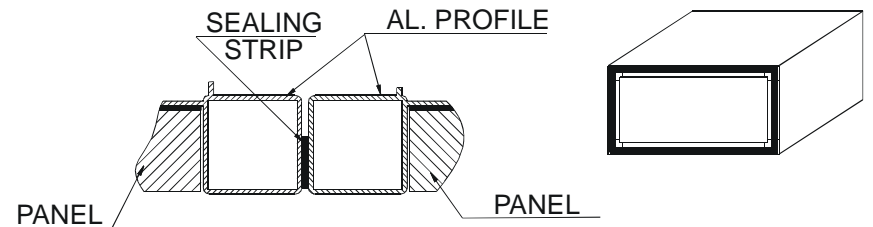

UNIT OUTSIDE

Method of applying a sealing strip to unit section joints

1.9.2.2 Assembly of unit sections

If the unit is supplied in more than one component (section), all unit sections are to be assembled (see the illustration)

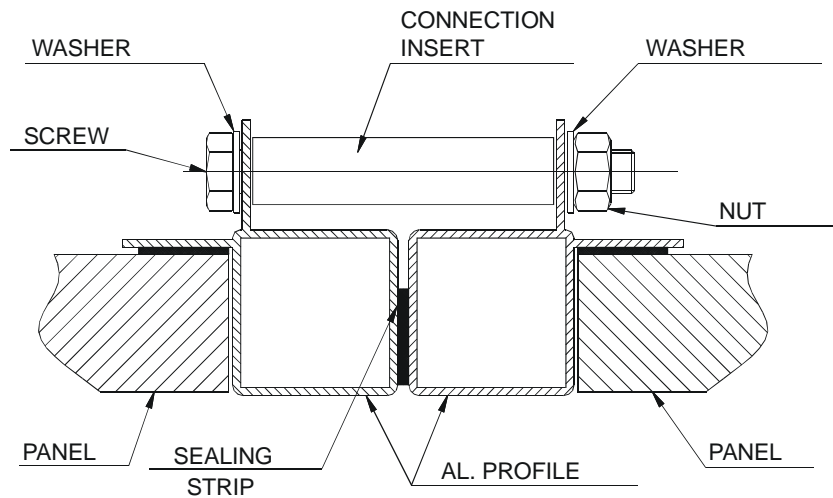

UNIT OUTSIDE

Joining sections in standard and outdoor design

Two to three bolted joints in each point where sections are assembled must have a star-like washer.

1.9.2.3 Unit positioning, suspending and levelling

The unit is most often ceiling-mounted or rather suspended from the ceiling. The suspending is carried out by using a threaded steel rod (supplied by the installing contractor) to which the unit is fixed by means of suspension elements (see the illustration).

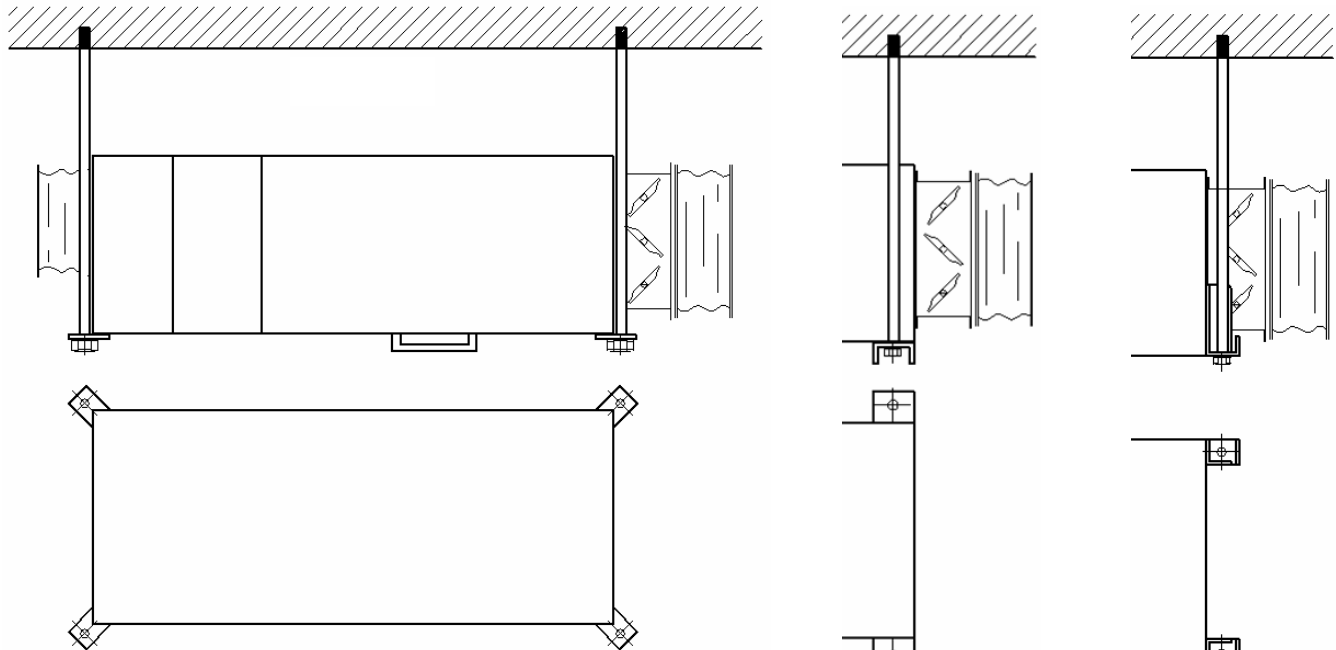

a) suspending by corner plates

b) suspending by profiles

c) suspending by supports

Methods of suspending the unit from the ceiling

1.9.3 KU-H Series

1.9.3.1 Sealing

If a unit is supplied in more than one component (section), one side of all joints of individual unit sections must be covered with a sealing strip.

The strip is to be applied to one side of the joint, longitudinally over the entire cross-section of the unit, without stretching the strip, on a clean surface, as close as possible to the inner surface of the panel (see the illustration).

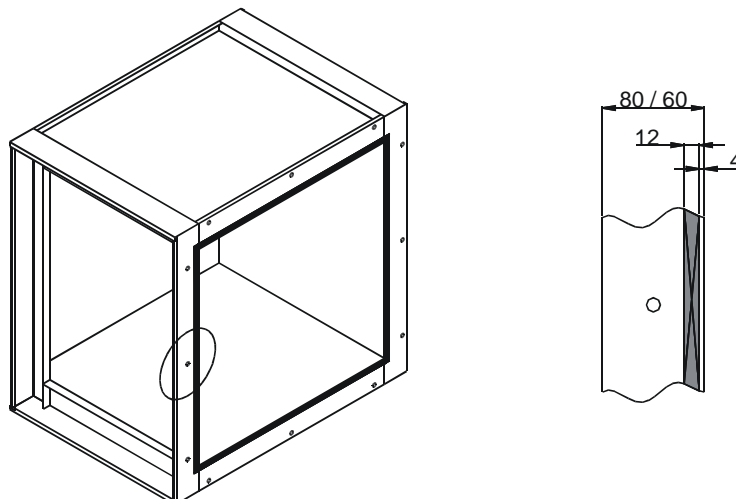

Method of applying a sealing strip to unit section joints

1.9.3.2 Unit positioning, shimming and levelling

Each unit section is to be placed in a corresponding location in the engine-room (according to the unit assembly plan) or any other location as may be specified by the design.

Rubber pads for sizes up to KU 6 are to be placed underneath the base in all section corners, and for unit sizes KU 6 – KU 19 in all section corners and in the middle of the section.

After rubber pads have been underlaid, all sections must be levelled.

1.9.3.3 Assembling sections by bolts

After having applied a sealing strip, sections are to be joined together by M8 x 20 mm bolts and A 8.4 nuts. In the segment of bottom panels the sections are joined solely by corresponding sealing rather than bolts.

Before assembling the sections they have to be lined up horizontally in direction of airflow through the unit and all section corners must be in agreement. After all sections have been joined together and the coupling bolts tightened, all built-in doors must open and close smoothly.

After having assembled the sections containing humidifier and cooler units all joints are to be sealed by an adequate sealing material.

The illustrations below show joints of various unit components:

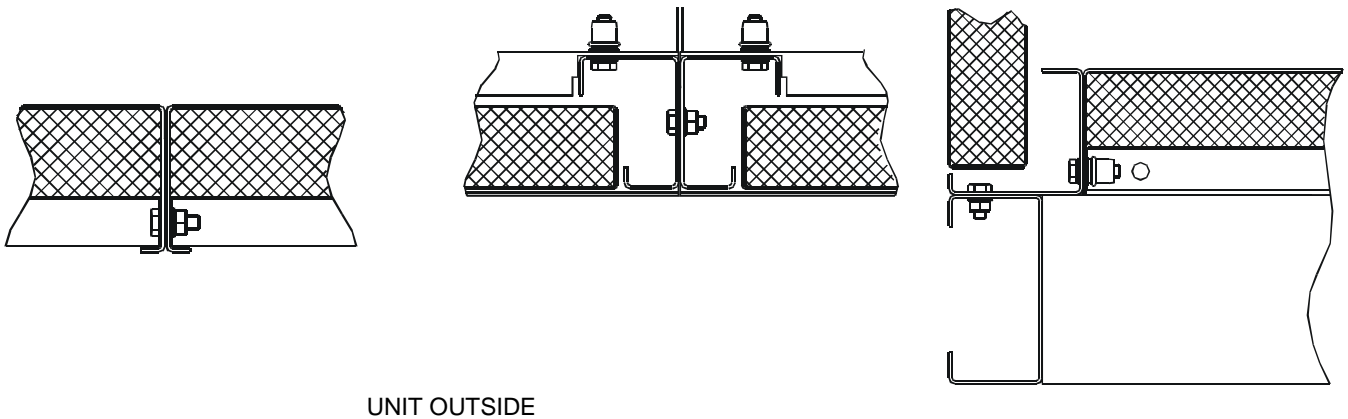

a) Panel joint

b) Front profile joint

c) Joint of the panel and unit base

Two to three bolted joints in each point where sections are assembled must have a star-like washer.

1.9.3.4 Assembling the roof (for outdoor design only)

The roofing steel plate joints must be protected by a joining profile. The joining profile is to be fixed on the roofing steel plate joint and holes for corresponding rivets or bolts (supplied by the installing contractor) are to be made at a distance of approximately 400 mm. One joining profile is to be supplied per each roof joint.

The roofing steel plate joints are showed in the illustrations below:

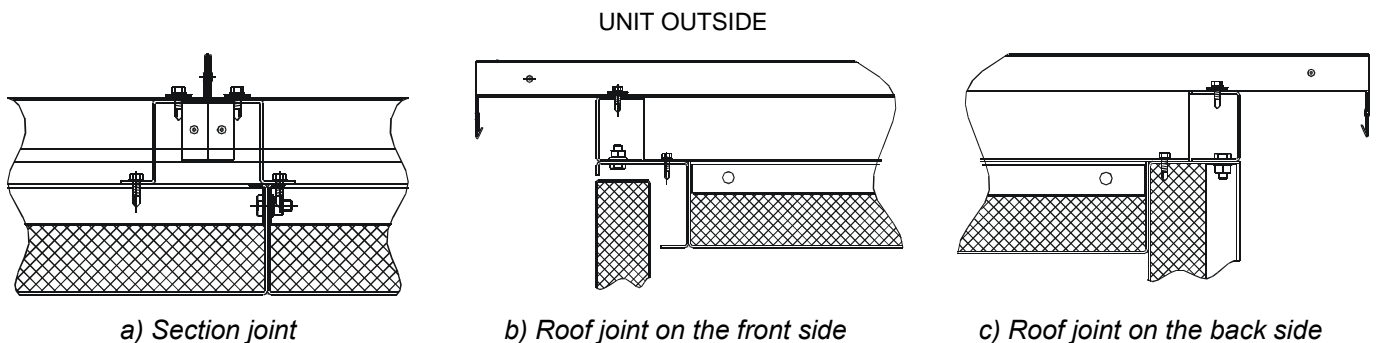

a) Section joint

b) Roof joint on the front side

c) Roof joint on the back side

2 INSTALLATION OF UNIT COMPONENTS

2.1 CONNECTING THE UNIT TO AIR DUCTWORK

In order to avoid vibration transmission the unit is connected to the air ductwork by means of flexible connections (integral part of the unit). As standard the flanges of flexible connections and the air duct are connected at angles by bolts, but in case of larger dimensions additional clamps are to be used (connecting material not included in the scope of supply).

The air ducts connected must be fixed on special supports or suspensions and the flexible connection is to be properly stretched by approximately 110 mm (see the illustration). The flexible connection ends are factory by-passed by a grounding tape.

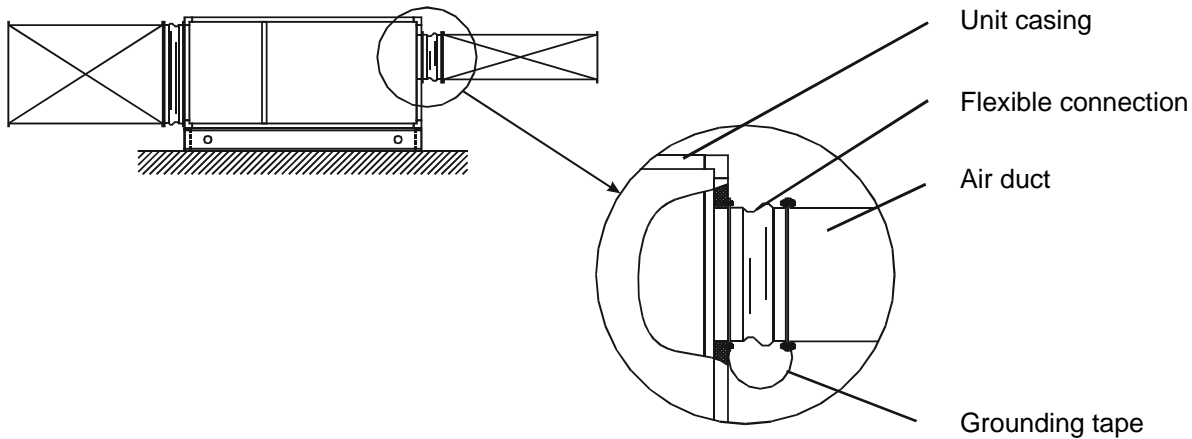

NOTICE : In air-handling units of a hygienic design, a minimum fresh air flow through the unit must be at least 1,200 m³/h.

It is advisable to connect a straight air duct or a mild transition piece at least 2 m long to the discharge connection. If impossible, the air duct elbow connected must be mounted in such a way to follow the fan rotation direction (see the illustration).

CORRECTLY:

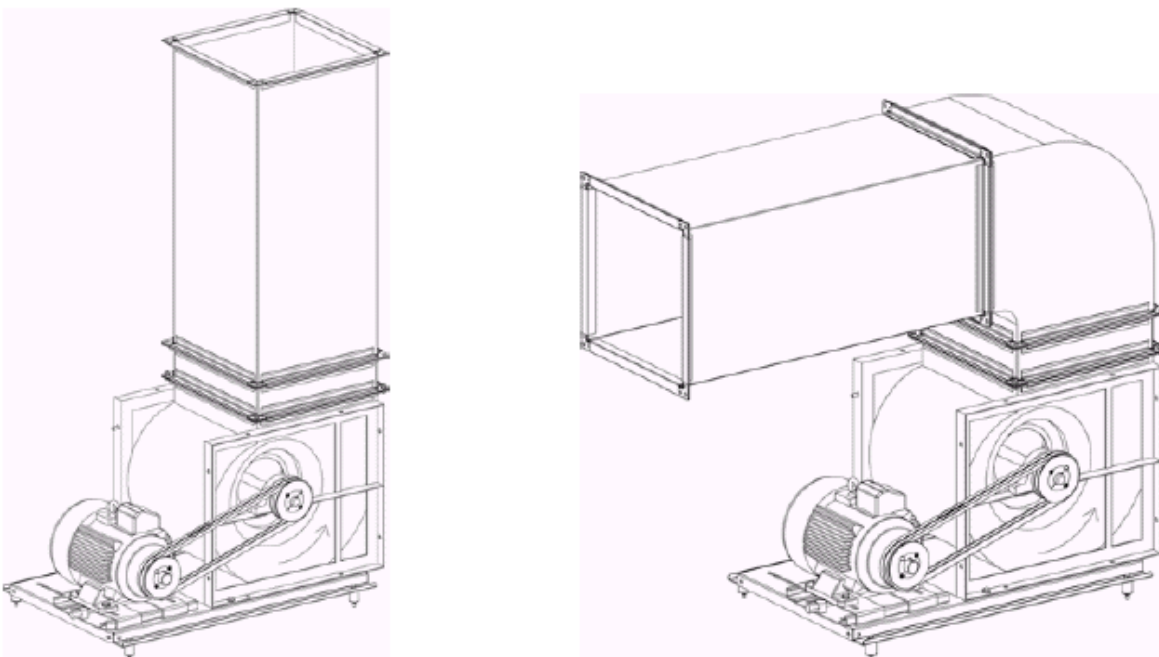

INCORRECTLY:

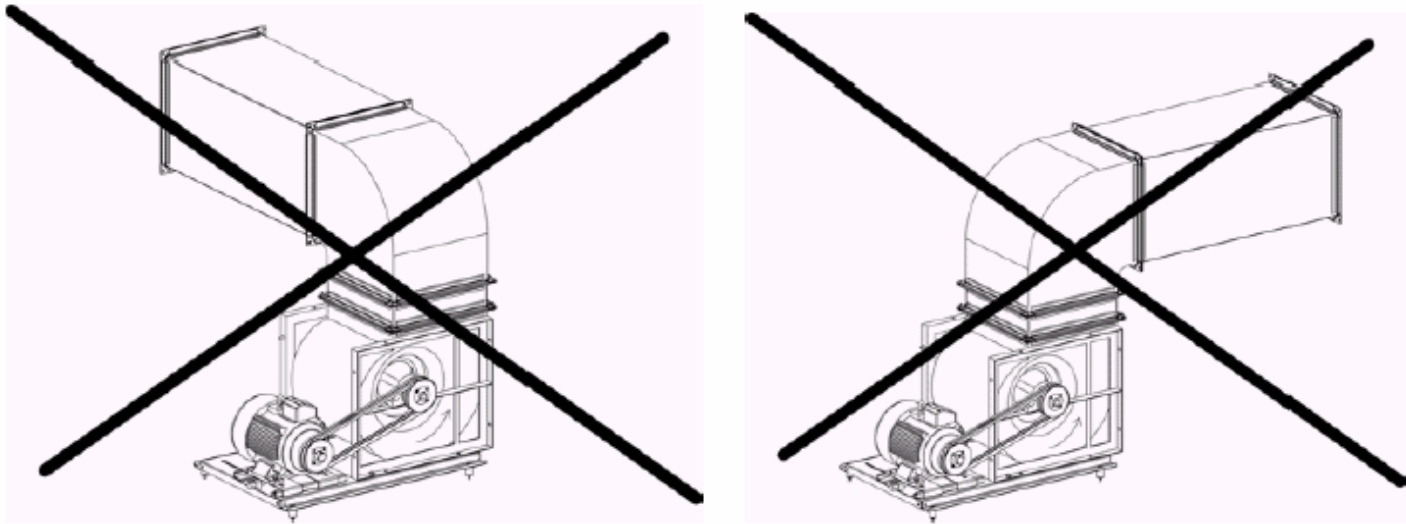

2.2 CONNECTING OF COILS

Coils (heaters, coolers) are to be connected to the hot/cold medium piping in such a way as to prevent the transmission of the piping and fittings weight and deformation caused by linear expansion during heating/cooling to the heat exchanger. Joints are to be decomposable (screwed pipe fittings or flanged joints) and the pipes with thermal insulation and fittings are to be arranged so to provide space for servicing filters, fans and other elements and facilitate the pulling out of exchangers for cleaning or replacement without emptying the entire system. When tightening a joint (screwed pipe fitting) the connection pipe is to be additionally held by an adequate wrench or pliers (see the illustration a).

The coil headers are equipped with air release and drain cocks. The valves for connecting coil inlet and outlet should be installed above the unit (min. 100 mm), so the coil could be disconnected and pulled-out for cleaning or replacement (see the illustration b)

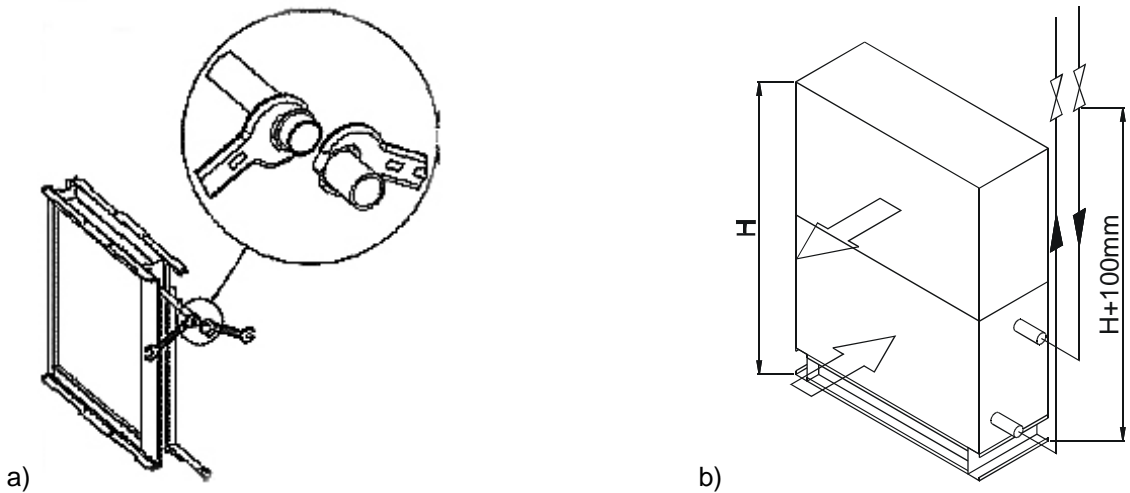

In order to ensure a proper operation of the heat exchanger the following steps are to be taken:

- a) Behind each hot water radiator (looking in the direction of airflow through the exchanger) an antifreeze thermostat is to be mounted and connected to the automatic control system (the thermostat is supplied as a part of the automatic control unit).
- b) The heat exchanger system of the multi-plate recuperator is to be filled with a water-ethylene-glycol mixture or a similar medium of a corresponding concentration depending on the lowest fresh air temperature designed.

Air coolers are placed in a condensate tray. Condensate removal from the tray is carried out by a nipple on the front or bottom panel of the cooler section to which a siphon of adequate size is to be connected.

Water inlet and outlet connections are to be mounted to the heat exchangers in such a way to ensure heating/cooling medium COUNTER-FLOW in relation to the airflow direction. (A parallel flow heat exchanger has a reduced capacity in relation to the counter-flow heat exchanger – by some 10% with heaters and by as much as 20% with coolers!)

2.2.1 Connecting of heating/cooling coils

A proper method of connecting heat exchangers to heating/cooling coil, water vapour and gas coolant piping is showed in the following illustrations :

2.2.1.1 Water heaters/coolers

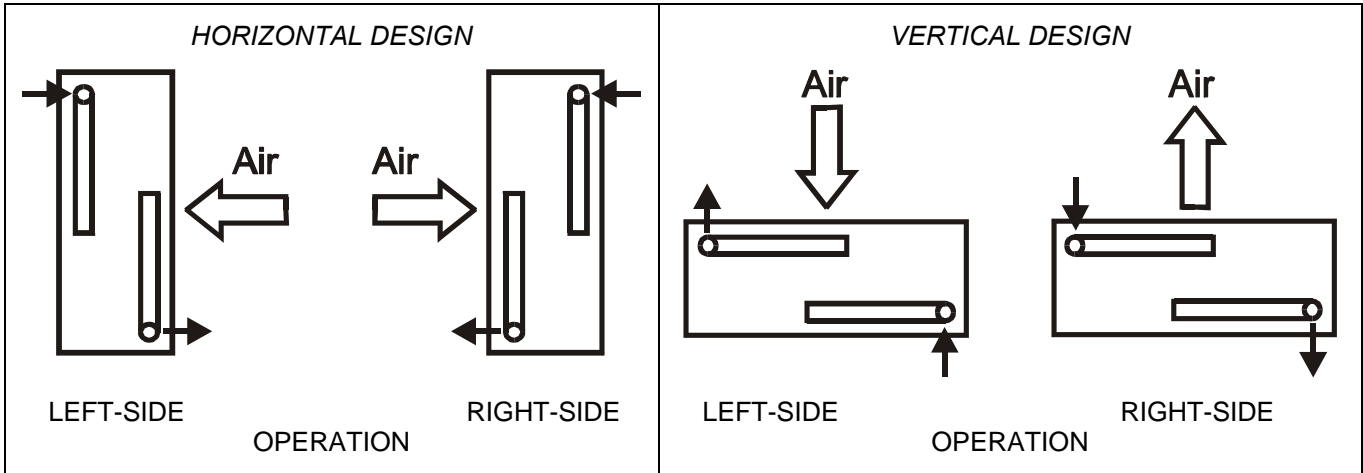

2.2.1.2 Steam heaters

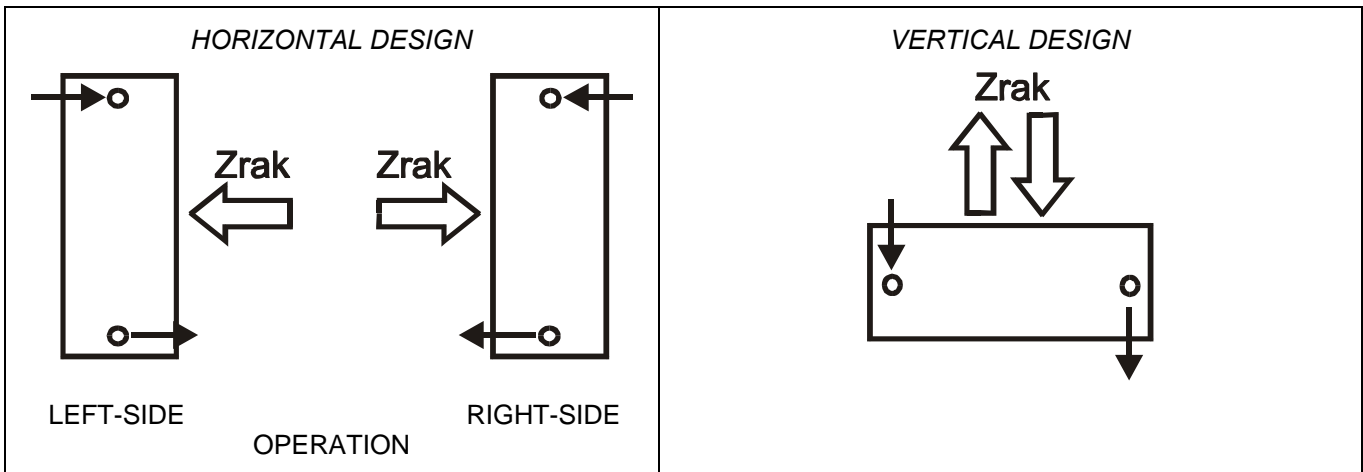

2.2.1.3 Freon coolers (evaporators/condensers)

⚠ CAUTION : Heat exchangers containing gas coolant (freon) are to be connected by a qualified person in accordance with the rules of refrigeration.

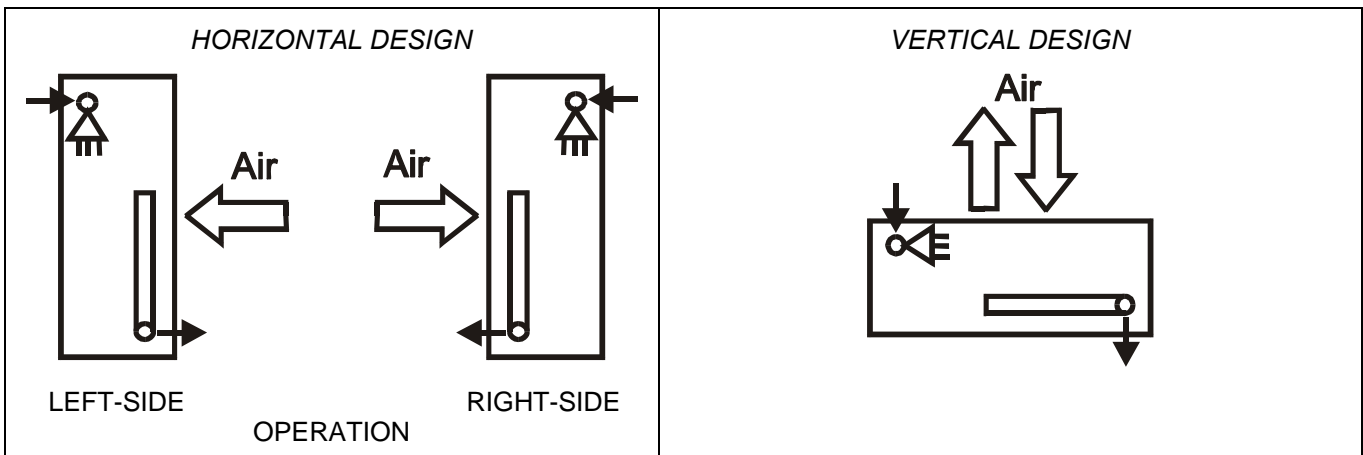

2.2.2 Connecting for the purpose of frost protection

For the purpose of protection against freezing the heat exchanger may be connected by a three-way valve, which facilitates mixing of the supply and return flow. The method of connecting is shown in illustrations below:

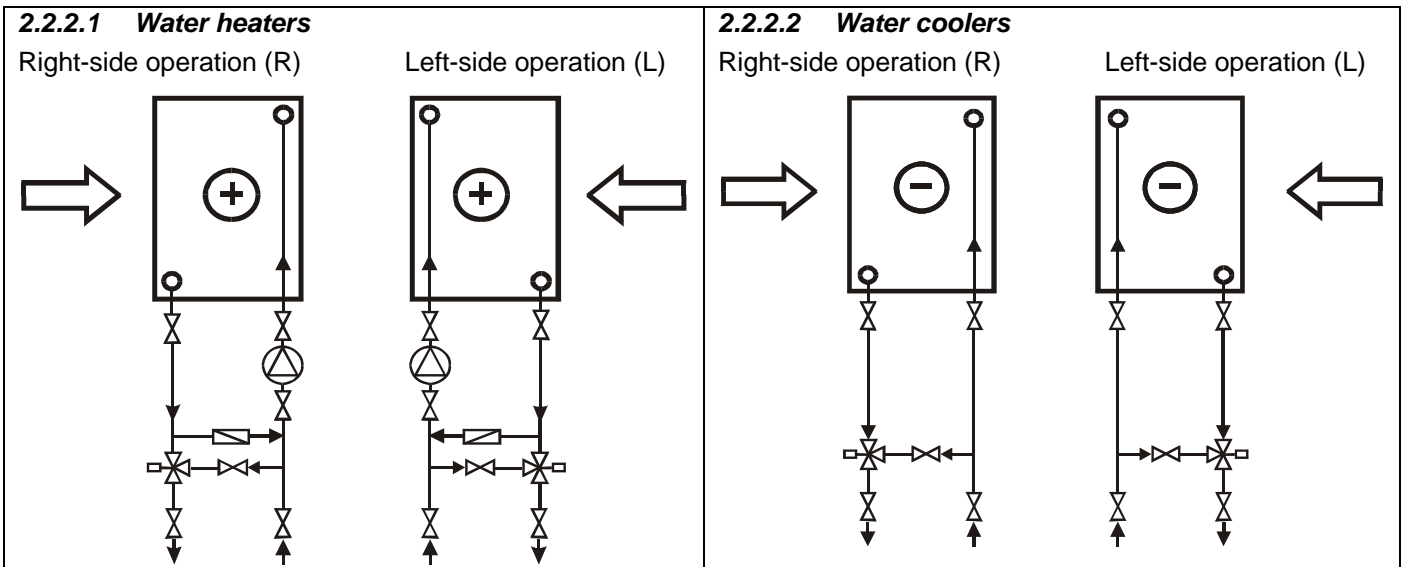

2.2.3 Connecting twin-coil heat exchangers

Twin-coil heat exchangers are to be connected according to the following schematic diagram :

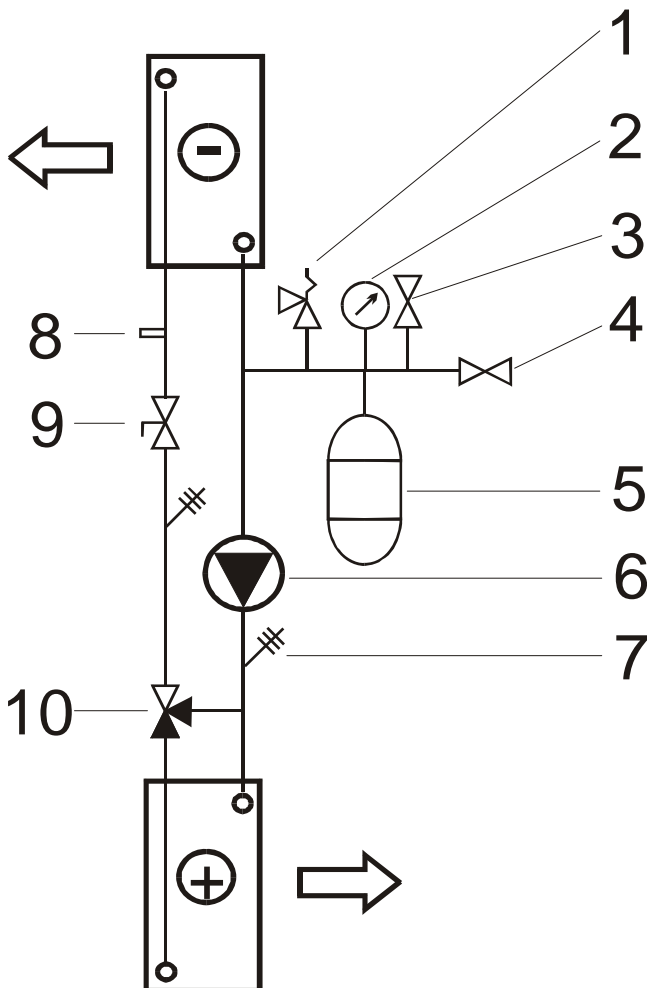

Key :

- 1. Safety valve
- 2. Pressure gauge
- 3. Air exhaust valve
- 4. Charging valve
- 5. Expansion vessel
- 6. Liquid recirculation pump
- 7. Thermometer
- 8. Temperature sensor location
- 9. Equalizing valve
- 10. Regulation valve

2.2.4 Allowable pressures

Minimum and maximum allowable pressures of media used (in absolute values) are indicated in the following table:

Exchanger type	Minimum pressure bar	Maximum pressure bar
Water/glycol	1.5	6
Steam	0.5	20
Freon evaporator /condenser	depending on evaporating/condensing temperature	20
Coil heat exchangers (heater/cooler)	1.5	6

2.3 CONNECTING SPRAY HUMIDIFIERS

Spray (honeycomb) humidifiers are fitted with a water container (tank), a pump, a coil and nozzles (honeycomb), including connections for feed water inlets through a float valve, liquid overflow through a siphon and a water drain.

The feed water supply must be carried out by means of a shutoff valve and a water filter (supplied by the customer or the installing contractor). The microbiological quality of feed water must meet the drinking water standards.

In order to prevent the scale build-up, water of a high degree of hardness (>14 °d) must undergo chemical treatments for water softening (e.g. by adding polyphosphates, by ionic exchange, decarbonisation etc.).

The maximum allowable carbonate hardness of feed water must not exceed 14 °d or a value laid down by special instructions of the humidifier manufacturer. The maximum allowable feed water temperature must not exceed 100°C.

NOTICE : To avoid the risk of freezing (in case of out-door designs) adequate electric heaters are to be mounted in the tray and in siphons

2.3.1 Allowable pressures

Minimum and maximum allowable feed water pressures (in absolute values) are indicated in the following table:

Humidifier type	Minimum pressure bar	Maximum pressure bar
Humidifier with nozzles	1.1	4.5
Humidifier with honeycomb and water circulation pan	5	10
Humidifier with honeycomb and direct water evaporation on the honeycomb	1.5	10

2.4 CONNECTING STEAM HUMIDIFIERS

A steam humidifier unit consists of a casing and a steam humidifier with corresponding connections for steam supply and condensate drain. The microbiological quality of feed water must meet the drinking water standards. Feed water of a high degree of hardness (>14 °d) must undergo adequate chemical treatments for water softening (e.g. by adding polyphosphates, by ionic exchange, decarbonisation etc.).

As standard the steam humidifier is supplied in two designs: as a steam power humidifier and a humidifier with a central steam generation.

Vapour lances of a steam power humidifier are mounted in the casing interior and connected by steam supply pipes to the steam power generator placed in the engine-room, independently of the unit. Condensate drain from a vapour lance shall not be connected directly to the sewage pipe, but only through a free discharge point. The steam power generator must be installed by a person qualified for connecting electrical installations.

The low-pressure steam network of a humidifier with a central steam generation is mounted in the casing interior and connected to the low-pressure steam coil by a separate connection on the unit casing and by a control valve (supplied by the customer or the installing contractor). The absolute steam pressure may be maximum 1.5 bar.

When mounting, starting up, maintaining and servicing the unit it is necessary to follow instructions supplied by the steam humidifier manufacturer.

2.5 SIPHON MOUNTING

During the operation of the unit condensate is generated on the air cooler unit, TWIN-COIL and multi-plate recuperator, which is then collected in adequate containers (drain pans). Condensate drainage from the unit is performed by means of a siphon of a corresponding height, depending on overpressure or rather subatmospheric pressure at the point of connection.

- with overpressure at mounting location

$$H_1 = 30 \text{ mm}$$

$$H_2 = p + 30 \text{ mm}$$

- with underpressure at mounting location

$$H_1 = p + 30 \text{ mm}$$

$$H_2 = p / 2 + 30 \text{ mm}$$

where

p means medium pressure at the mounting location in [mm VS]
(1 mm VS = 10 Pa)

The nominal size ϕD of the siphon is determined according to the following table:

Unit size	ϕD
KU-P 1 – KU-P 3	1 "
KU 1 – KU 6	1 "
KU 7 – KU 12	1 ¼ "
KU 13 – KU 17	1 ½ "
KU 18 – KU 24	2 "

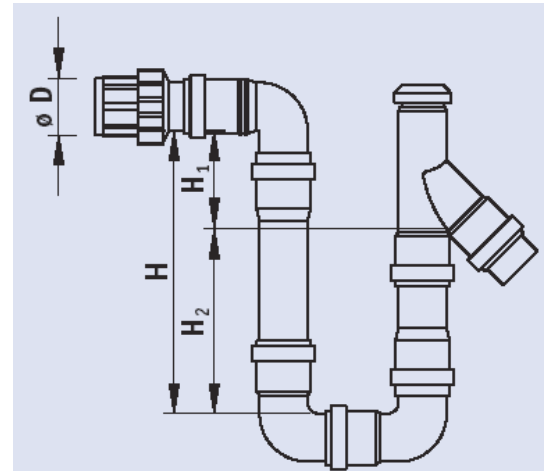

The water outlet from the siphon must not be connected directly to the sewage pipe, but rather through a free discharge drain (see the illustration).

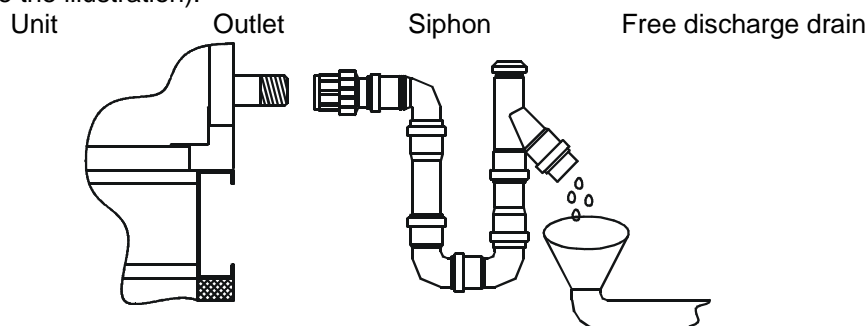

Method of connecting a siphon to the unit and a free discharge drain

The end of the drain pipe must be open above the free discharge drain. A siphon must be mounted for every drip pan in the unit. Due to pressure differences in individual unit components it is not allowed to connect several condensate drains to one siphon. Before unit start up the siphon is to be filled with water.

NOTICE : In case that siphon water may be frozen, the siphon must be thermally insulated or rather an adequate siphon heater fitted.

2.6 UNITS WITH BURNERS

The unit with a burner consists of a casing, a by-pass line with a built-in damper and a gas burner. The heat exchanger is made of steel sheet and consists of a combustion chamber, a coil and a flue gas chamber with a gas exhaust connection.

The gas burner is connected to the combustion chamber inlet on the service side by an adequate flanged joint, and the flue gas chamber with a gas exhaust connection is located on the rear side of the unit.

With units of the out-door design, efficient ventilation of the engine-room and an adequate flue gas exhaust system (flue stack) must be provided. A unit with a burner must be connected to the flue stack in compliance with the requirements for flue stacks. All joints must be air-tight to prevent possible condensate leakage into the environment. When connecting to the flue gas exhaust system it is necessary to consult the chimney-sweeping service and observe all legally prescribed fire-prevention standards.

The gas supply to the gas burner must be performed in such a way as to facilitate access and pulling of individual components out of the unit with a burner.

When mounting, starting up, maintaining and servicing the unit it is necessary to follow instructions supplied by the burner manufacturer.

2.6.1 Gas ramp schematic diagram

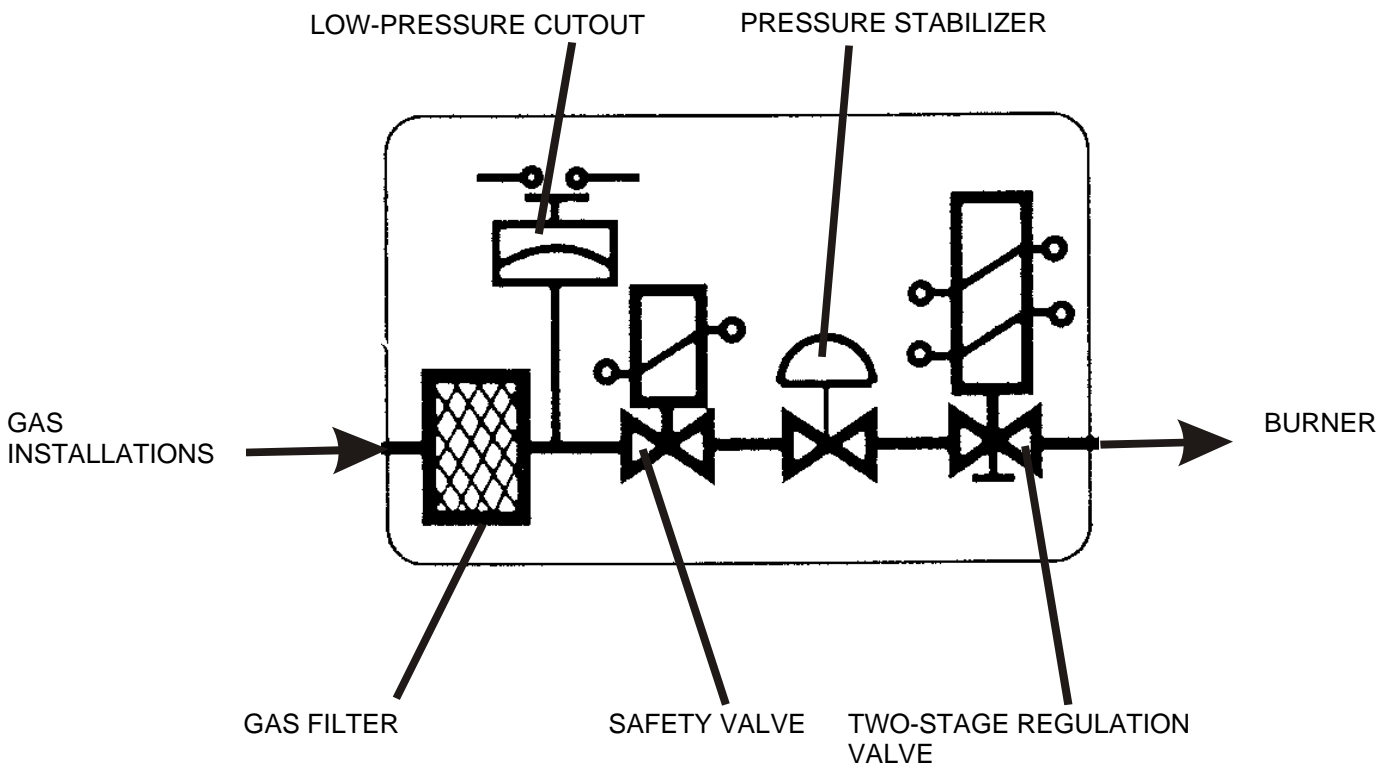

2.7 DAMPERS

Dampers consist of a number of aluminium blades bordered with a rubber seal and mounted into a common aluminium frame. PVC drive gears are placed sidelong within the frame and protected against dust.

The brass shaft for counter-flow movement of damper blades has a square cross-section of 12x12 mm and is about 200 mm long. The shaft is also designed for mounting a crank handle for manual activation of blades or an electric-motor drive. It is also possible to mount a lever for simultaneous activation of blades of two dampers for the purpose of mutual airflow control or closing/opening of dampers.

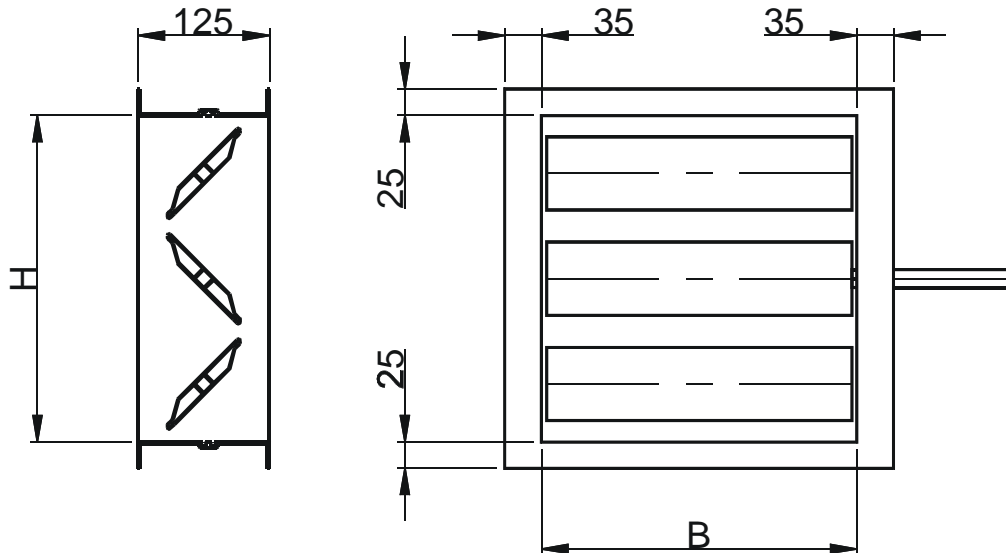

NOTICE : Please consider thermal insulation or adequate damper fins heater to be fitted in case of frost danger.

2.8 ELECTRIC-MOTOR DAMPER DRIVES

The selection of a corresponding electric-motor drive for dampers depends on the torque required for the damper to close. The value of the electric-motor drive torque required must be equal or higher than the value of that required for the damper to close, as indicated in the following table:

Unit size	Torque
KU-P 1-KU-P 3	2 Nm
KU 1 – KU 4	4 Nm
KU 5 – KU 7	8 Nm
KU 8 – KU 10	15 Nm
KU 11	18 Nm
KU 12 – KU 15	30 Nm
KU 16 – KU 17	2 x 18 Nm
KU 18 – KU 19	4 x 15 Nm
KU 20- KU 22	2 x 30 Nm
KU 23 – KU 24	4 x 30 Nm

In case of a parallel operation of dampers (dampers interconnected by an adjusting arm) using a single electric motor the above values are to be multiplied by 2.

3 ELECTRICAL INSTALLATIONS



CAUTION :

Each connecting of electrical components of the unit (electric motors, electric-motor damper drives, electric heater, automatic control components, etc.) is to be performed by a qualified and well-trained person in conformity with applicable standards, guidelines (VDE etc.) and legislation.

Before starting the connecting procedure it is necessary to check the conformity of the mains voltage, frequency and number of phases with the data specified in the technical data sheet or other manufacturer's documents accompanying the unit. In case of any deviations it is not advisable to carry out the connecting operations. When laying especially long cables the cross-section sizes of cables used must be additionally checked.

3.1 WIRING

All cable penetrations through panels must be airtight and protected against damage that may be caused by sharp edges. Panel penetrations may be performed by drilling or saw cutting and adequate electrical conduits are to be mounted.

Pg		
Conduit size	Panel penetration diameter	Connection cable outer diameter
Pg 11	28 mm	9 – 11 mm
Pg 13.5	32 mm	12 – 14 mm
Pg 16	35 mm	14 – 16 mm
Pg 21	42 mm	19 – 21 mm
Pg 29	55 mm	26 – 28 mm
Pg 36	70 mm	30 – 32 mm
Pg 42	75 mm	35 – 37 mm
Pg 48	80 mm	34 – 44 mm

M		
Conduit size	Panel penetration diameter	Connection cable outer diameter
M20x1.5	28 mm	7 – 12 mm
M32x1.5	50 mm	13 – 18 mm
M40x1.5	60 mm	18 – 25 mm
M50x1.5	70 mm	25 – 38 mm

NOTE : Depending on protection class, dimensions stated above could be different and are subject to change without notice.

Inside the unit cables are to be laid in the way that provides the shortest possible connection of electric elements. They have to be sufficiently far from other moving components of the unit (e.g. belt transmission, fan wheel), adequately suspended (at unit edges, opposite to the service side, on top and side panels) and fastened (clips, lashings).

The wiring must be provided in a sufficient length and must provide access to all components that are to be taken out of the unit for any reason (cleaning, replacement).

3.2 ELECTRIC MOTORS

Electric motors are to be connected using the overload and short-circuit protection corresponding to the electric motor rated current. The electric motor is fitted with a burnout protection in a form of three PTC thermistors connected in series and mounted into electric motor windings. Thermistors must be connected to an electronic instrument for measuring the winding temperature.

Prior to connecting to the mains it is necessary to make sure that below mentioned diagrams correspond to the data on the motor nameplate and instructions for electric motor installation and maintenance.



WARNING :

IN ORDER TO PROVIDE SAFE REPAIR OF THE UNIT, THE CUTOUT SWITCH THAT INTERRUPTS THE CURRENT SUPPLY OF THE FAN ELECTRIC MOTOR DURING REPAIR MUST BE MOUNTED OUTSIDE THE FAN UNIT. BEFORE OPENING THE FAN UNIT SERVICE DOORS (DUE TO FAILURE, REPAIR, STOPPING, ETC.) MAKE SURE THAT CURRENT SUPPLY OF ALL ELECTRICAL COMPONENTS IS CUT OFF.

NOTICE :

Electric motors of 4 kW rated power are started directly. With rated power of 5.5 kW and higher they are started by means of a star-delta starting connection (see the drawings).

3.2.1 ELECTRIC MOTOR DIRECT STARTING

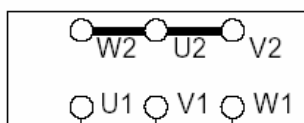
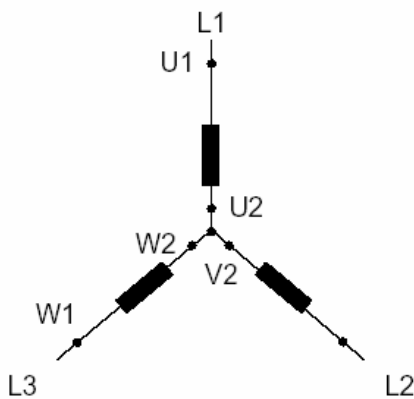
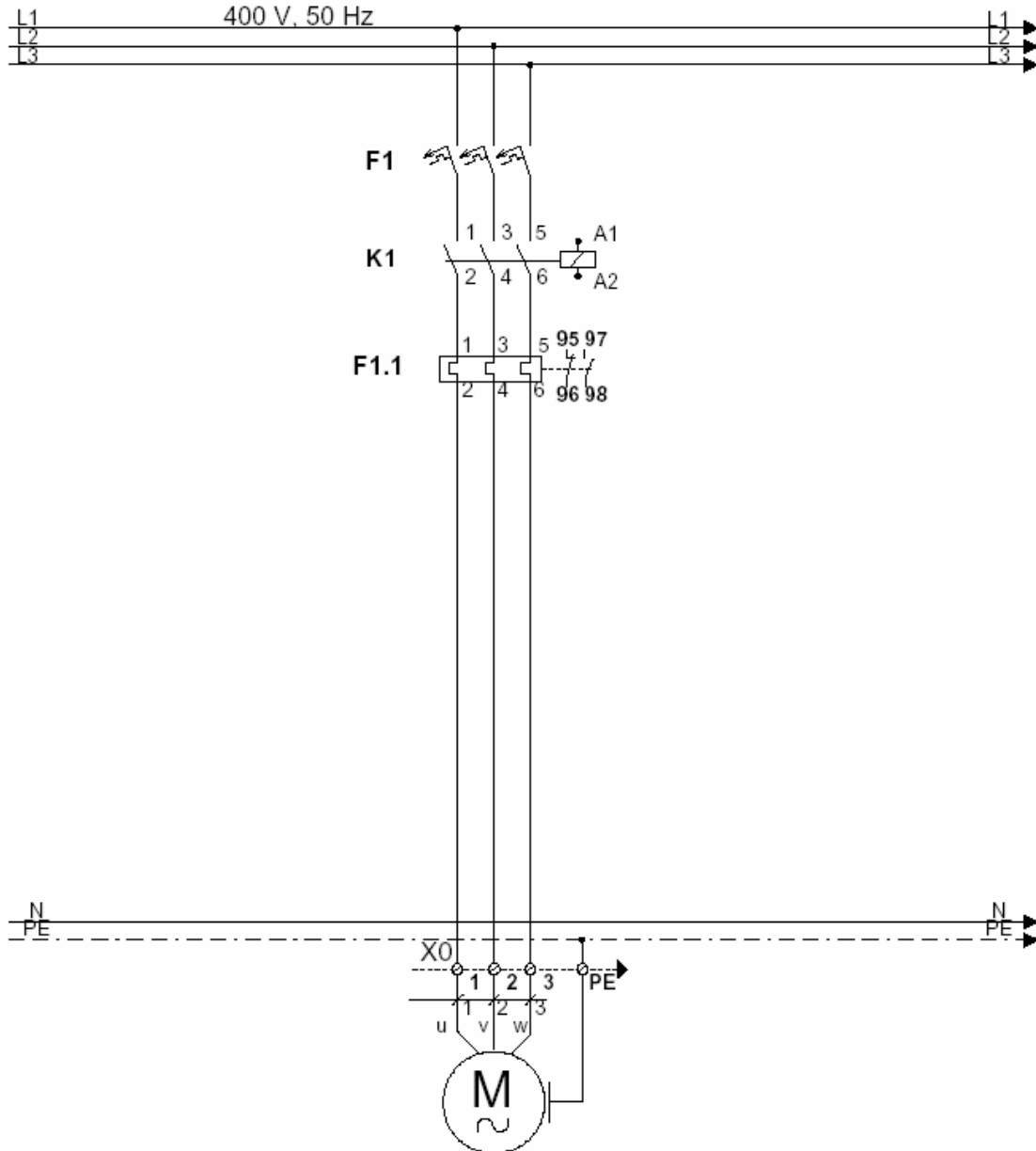

STAR CONNECTED MOTOR
($P_m < 2,2 \text{ kW}$)

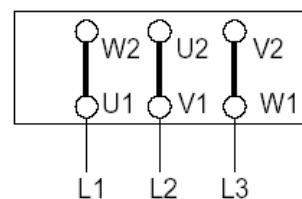
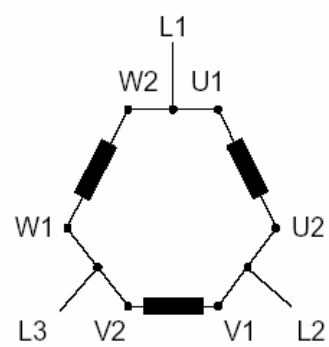

DELTA CONNECTED MOTOR
($P_m \geq 2,2 \text{ kW}$)

3.2.2 STARTING TWO-SPEED ELECTRIC MOTORS WITH TWO SEPARATE WINDINGS

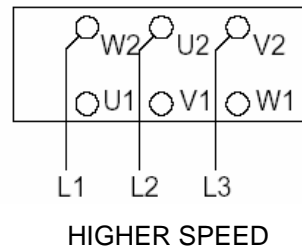
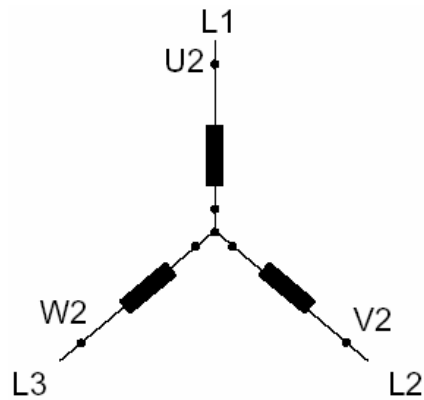
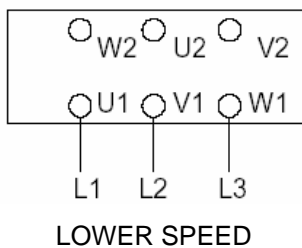
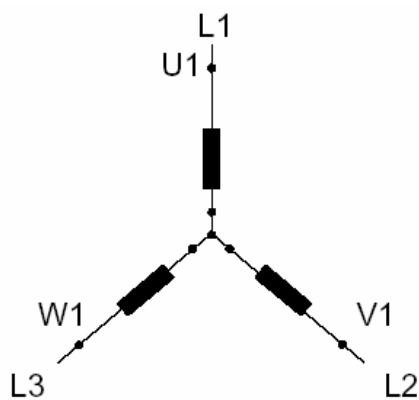
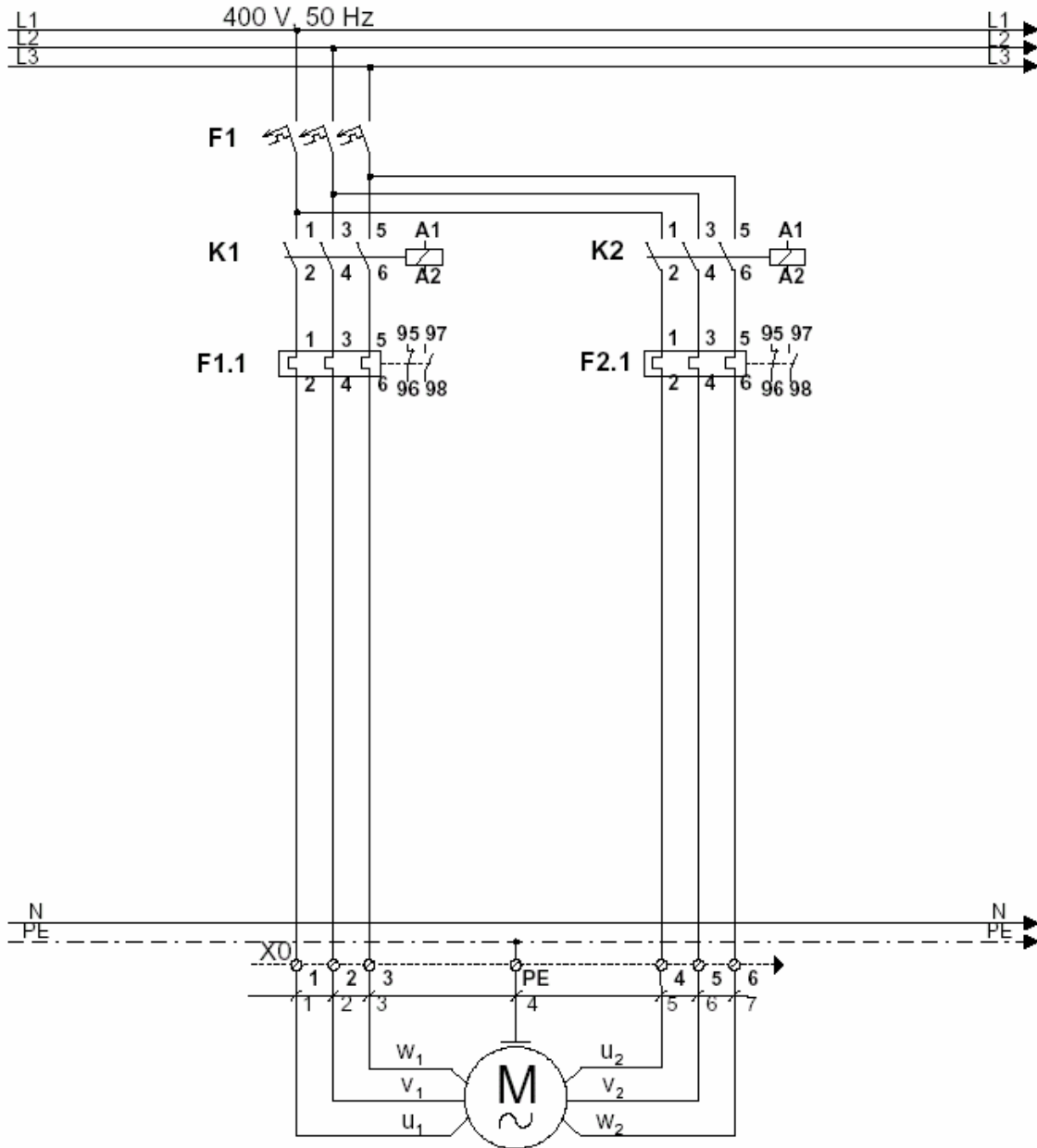

3.2.3 STARTING TWO-SPEED ELECTRIC MOTORS WITH WINDINGS IN DAHLANDER CONNECTION

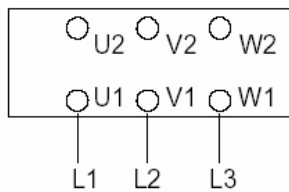
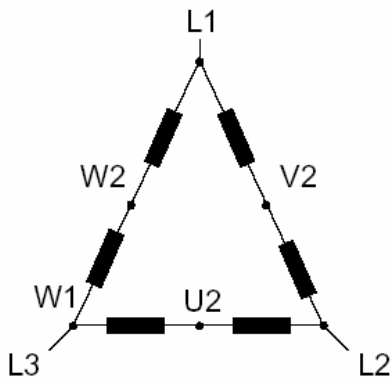
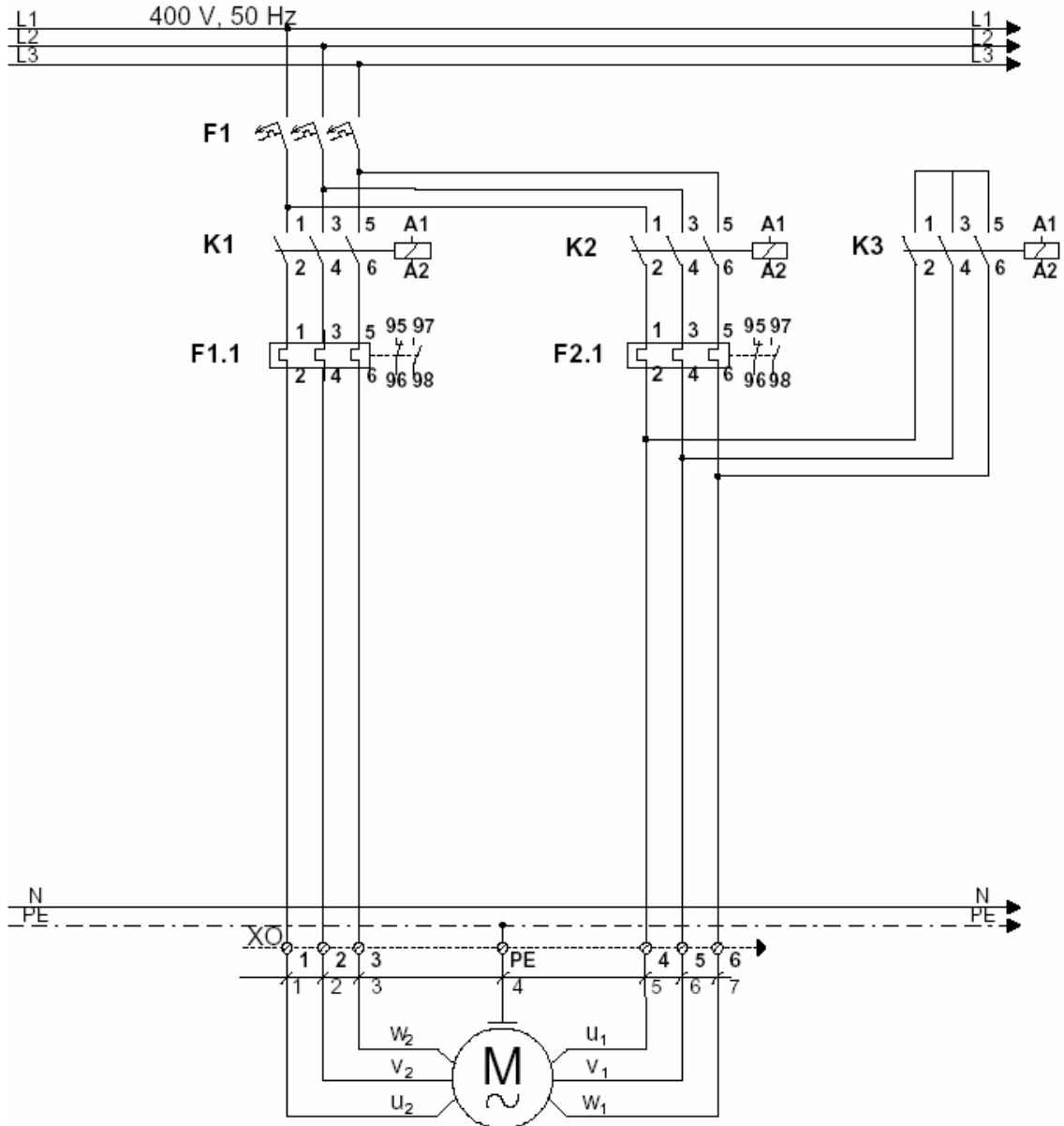

DELTA (STAR) CONNECTED MOTOR

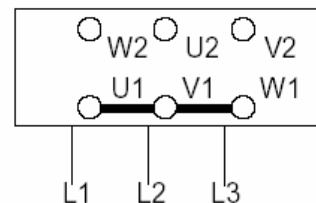
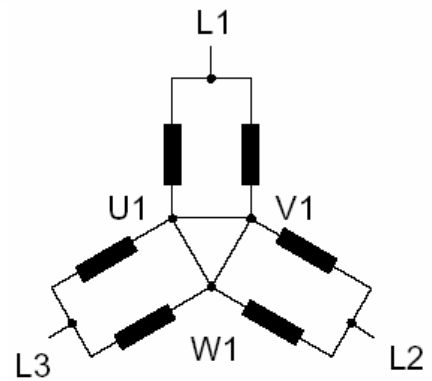

STAR-STAR CONNECTED MOTOR

3.2.4 STARTING ELECTRIC MOTORS WITH START-DELTA COMBINATION

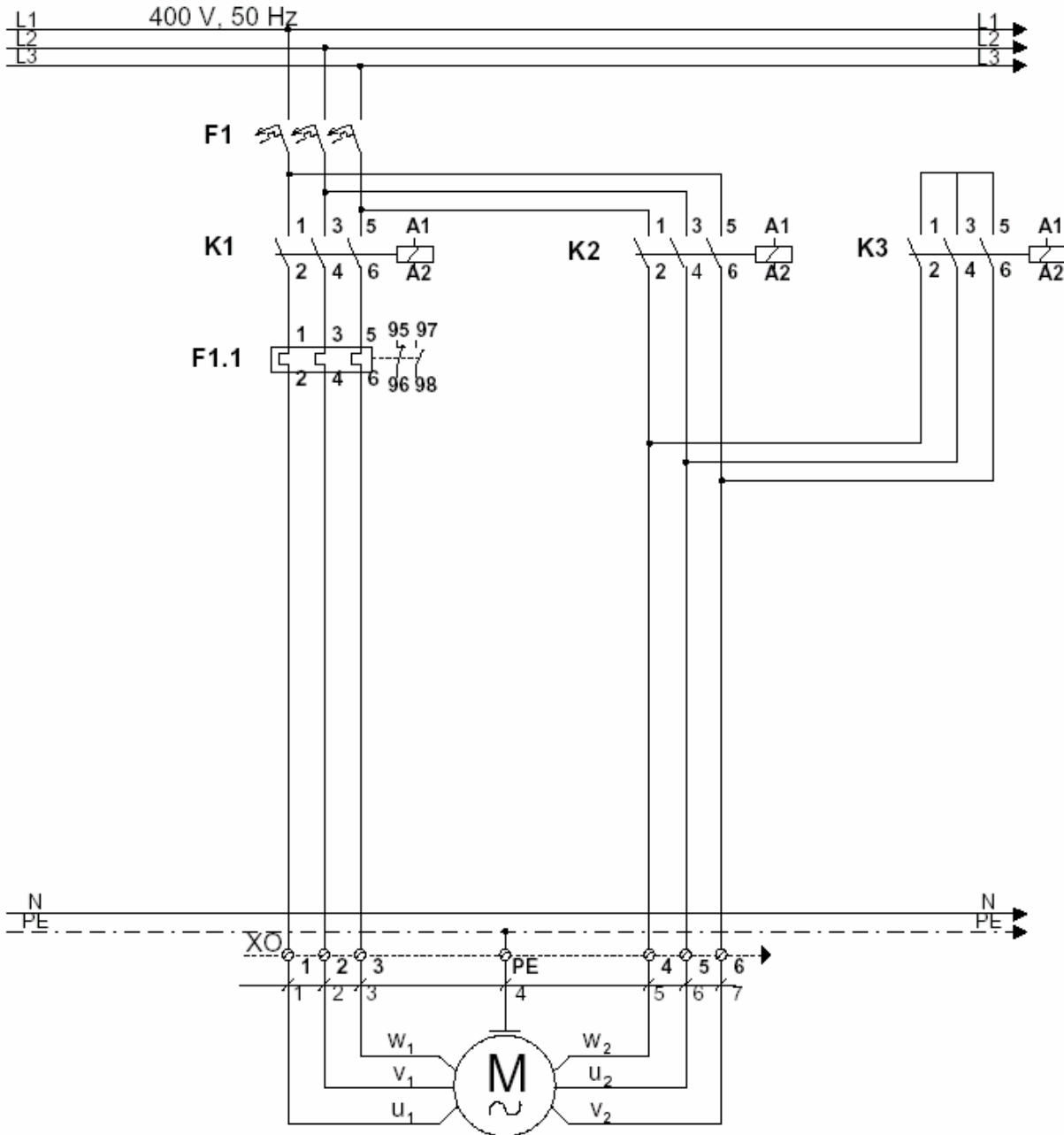

3.3 ELECTRIC HEATERS

An electric heater must be connected in the manner that prevents its activation when the fan is not running. Besides, when putting the fan out of operation it must be provided that the electric heater is switched off too. Each electric heater coil is connected separately to the connection box, placed generally on the external side of the electric heater unit panel, on the service side of the unit. Electric heater components are accessible after dismantling the service panel of the electric heater unit.

Depending on the automatic control system applied the heater capacity control may be continuous or stepwise. For a stepwise heater capacity control heating coils are to be joined in groups of three (heating units are not factory-divided into groups). The electric heater casing has ground connections and connections for a safety thermostat that provides over-temperature protection of the electric heater in case that the airflow does not exist or is insufficient. The safety thermostat has been factory-set to a temperature value at which the electric heater supply is cut off. The resetting of the safety thermostat after activation is performed manually.



CAUTION :

It is imperative that a safety thermostat is fitted into the electric heater control system.

3.4 SPRAY AND STEAM HUMIDIFIERS

The water pump and lighting are connected to the power supply through the spray humidifier unit. The water pump electric motor supplied has a nominal voltage of 1 x 230 V or 3 x 400 V / 50 Hz. The connecting is to be carried out using the data and instructions contained in the motor nameplate and the motor manufacturer's instructions attached.

The motor and the pump rotation direction must comply with the indication on the pump casing.

The steam power generator must be connected in accordance with the instructions supplied by the steam power generator manufacturer. The lighting is to be connected to the power supply by means of a control switch-box.

3.5 ROTARY WHEEL HEAT EXCHANGERS

A rotary wheel heat exchanger is driven by an electronic speed control unit, a wheel rotary wheel motor and a belt transmission. The speed control unit mounted in the recuperator casing performs several standard functions that ensure the optimum heat recovery depending on the mode of operation (summer/winter) and motor protection. The system is adjusted to receive standard measuring signals, e.g. 0-10 V or 0-20 mA. The wheel rotary wheel motor is fitted with a connection for one-phase alternate current of 230 V / 50 Hz (for rotary wheel heat exchanger casings of a nominal size of 999 mm) or three-phase alternate current of 400 V / 50 Hz (for rotary wheel heat exchanger casings of a nominal size of 1000 mm and more).

The rotary wheel heat exchanger motor and controller unit are to be connected in accordance with the rotary wheel heat exchanger manufacturer's instructions.

3.6 CONTROL SWITCH-BOXES



CAUTION :

The control switch-box electric components and automatic control elements are to be connected by a qualified and well-trained person in conformity with applicable standards, guidelines (VDE etc.) and legislation.

NOTICE:

The control switch-box is not supplied as standard together with the unit, but only on a special customer's request.

The control switch-box components depend on the unit configuration, the scope of functions monitored and controlled and on special requirements of the customer or conditions specified in the design documents.

If supplied, the control switch-box is to be placed in the engine-room as indicated in the design. It is not allowed to install the control switch-box in the open air, exposed to rain and sun. The control switch-box should be placed as close to the unit itself as possible, and if impossible, then it should be positioned near automatic control elements installed in the engine-room.

Control switch-boxes of smaller dimensions are fastened on the wall by bolts and suspension elements (supplied by the installing contractor). Larger boxes are supplied as freestanding units and it is advisable to fix them also on the wall.

When fixing is completed, the main feeder cable is to be laid and led into the control switch-box. After that field equipment (sensors, electric motor drives, etc.) is to be properly hooked up with the control switch-box in accordance with the technical data contained in the design documents. Electric cables laid are to be blanked off, inserted into the elements and marked distinctly and visibly on both cable ends.



CAUTION :

When connecting the main feeder cable to the control switch-box, make sure that the power source is disconnected.

3.7 AUTOMATIC CONTROL ELEMENTS

Automatic control elements are normally not supplied as a part of the unit, but on the customer's request only. Automatic control is an integral part of each ventilation system and facilitates its normal operation. Non-existence of an adequate control may cause operating troubles, shutdowns and unit failures.

These instructions do not include documents and data relating to installation of automatic control elements, their connecting, putting into operation, maintenance and servicing. They are specified in documents supplied by manufacturers or suppliers of automatic control elements and are separately furnished to the customer. In all other cases the supplier of automatic control elements is bound to attach relevant instructions for installation and putting into operation.

4 PREPARATIONS FOR INITIAL COMMISSIONING

Before unit commissioning the following checks are to be performed and defects or failures eliminated:

- all ventilation devices are mechanically installed and connected to the air ductwork;
- hydraulic and freon units are completely installed and ready for operation;
- heating/cooling media are available during the commissioning procedure;
- the unit and the pertaining electrical elements are wired and ready for operation;
- siphons and systems for condensate drainage from condensate pans are installed, connected to free points of discharge and filled with water;
- all monitoring and control elements are installed and wired;
- the unit interior and air ducts are cleaned;
- protective foils and reinforcement and fastening elements needed during the unit transportation are removed;
- factory-mounted components of the unit are not damaged during transport or assembly;
- all service panels and service doors of the unit are properly fixed and closed.

4.1 Electric system

- Check that all electrical components are connected.
- Check that power supply of all electrical components corresponds to the standards and electrical diagrams attached.

4.2 Dampers

- Check that dampers are properly fixed and tight.
- Check that, when rotary wheel the shaft, the blades move freely.
- Check the blades for dirt and mechanical damage.
- Check that the crank handle or control levers are properly connected and functional.
- Check that electric-motor drive (if included in the scope of supply) is fastened and wired.

4.3 Filters

- Check the condition of filter cartridges and their tightness; check that they are properly fixed to the filter holding frame.
- Remove the protective foil from filter cartridges (if the cartridges are shrink wrapped).
- Before commissioning the facility and the unit must be cleaned from dust.
- Elements for measuring filter cartridge contamination (pressure switches, gauges) are to be connected and their method of installation, functioning and set values checked.



CAUTION :

At the initial commissioning of the unit using built-in absolute filters, perforated screens are to be used instead of absolute filters so as to compensate for the pressure drop on filter cartridges.

NOTICE :

It is recommended that the initial commissioning of the unit fitted with double filters is performed without built-in fine filters. They should be mounted after a thorough cleaning of the space and completion of the initial commissioning.

4.4 Coils – heaters and coolers

- Check that heat exchangers are correctly connected (in the counterflow).
- Check the condition of heat exchanger lamellas (contamination, mechanical damage).
- Check the hot/cold medium (water), steam and/or refrigerant supply.
- Check the functioning of the piping system and control elements.

- Check that the recirculation pump is properly connected to the coil and that it turns in the correct direction.
- Check that the unit is filled with process medium (water, ethylene-glycol-water mixture) and de-aerated.
- Check that a protective antifreeze thermostat is correctly mounted behind the heat exchanger; if yes, check and adjust the set value to +4°C (adjust before operating the unit in the winter mode).
- Check that the three-way regulating valve is installed in accordance with the indication on its housing.
- Check that the droplet eliminator is correctly installed behind the cooler.
- Check the size of siphons mounted; check the connections to points of discharge and check that the siphon is filled with water.

NOTICE : Checking, testing and adjusting of the cooler – evaporator and the condensers filled with the gas coolant (freon) are to be performed by a certified maintenance technician for refrigerating equipment.

4.5 Electric heaters

- Check that all connections are carried out properly and without any damage.
- Check that the electric heater coil is properly connected (according to the wiring diagram attached) and grounded.
- Check that the built-in safety thermostat is properly connected.
- Check set values of protective devices (safety thermostat, fuses, etc.).

4.6 Spray humidifiers

- Check the general condition and cleanliness of the humidifier section interior.
- Check the pump for correct functioning and the condition of electrical installations fitted.
- Check that the device is correctly installed (behind the pump) and check the water filter for contamination (supplied by the installing contractor).
- Check that feed water supply and quality (hardness, microbiological quality) are in accordance with the design.
- Check the functioning and proper adjustment of the float valve.
- Check that water pan drainage system and antifreeze protection (pans, siphons) are properly installed.
- Fill the water tank (under the humidifier) with water up to the level of 20 mm below overflow and adjust the float valve.
- Check that recirculation pump is properly connected to the coil and verify proper rotation direction.
- Check sizes of siphons mounted, connections to free points of discharge and siphon water charge.



CAUTION : To avoid risk of possible damage the pump must not be run dry.

4.7 Steam humidifiers

- Check that gas supply is provided and adequate fittings mounted.
- Check the vapour lance for proper installation.
- Check the steam power humidifier for its position, properly mounted electrical installations and water supply.
- Check that feed water supply and quality (hardness, microbiological quality) correspond to the design.
- Check that condensate drain pipes are properly joined and connected to free points of discharge.

4.8 Twin-coil heat exchangers

- Check that exchangers are correctly connected (in the counterflow).
- Check the condition of exchanger lamellas (dirt, mechanical damages).
- Check that hot/cold process medium supply is provided.
- Check that piping and fittings are connected in accordance with the design and check that the safety valve and the expansion vessel are functional.
- Check that the piping is charged with nonfreezing liquid of a corresponding concentration.
- Check that the recirculation pump is properly connected to the coil and that its rotation direction is correct.
- Check that the protective antifreeze thermostat is properly mounted behind the heater and if yes, check and adjust the set value to +4°C (adjust before operating the unit in the winter mode).
- Check that the three-way regulating valve is mounted in accordance with the indication on its housing.
- Check that the droplet eliminator is correctly installed behind the cooler.
- Check the size of siphons mounted; check the connections to points of discharge and check that the siphon is filled with water.

4.9 Plate heat exchangers

- Check the condition of heat exchanger lamellas (dirt, mechanical damage).
- Check the function of the damper by-pass, if mounted.
- Check that the droplet eliminator, if any, is properly mounted.
- Check the size of siphons mounted; check the connections to points of discharge

NOTICE : Prior to the initial commissioning the by-pass damper is to be closed.

4.10 Rotary wheel heat exchangers

- Remove the V-belt from the rotation wheel and verify free wheel rotation.
- Check the clearance between the wheel and the casing and adjust sealing brushes (if required).
- Check that all sensors are mounted and connected to the rotation wheel.
- Check that the rotation wheel and motor wiring is made correctly.
- Check the vessel for cleaning the wheel.
- Check the belts for proper tension.
- Check the wheel for a proper rotation direction (in accordance with the indication on the heat exchanger housing).
- Make sure that electric motor feeder cables are laid sufficiently far from moving parts.

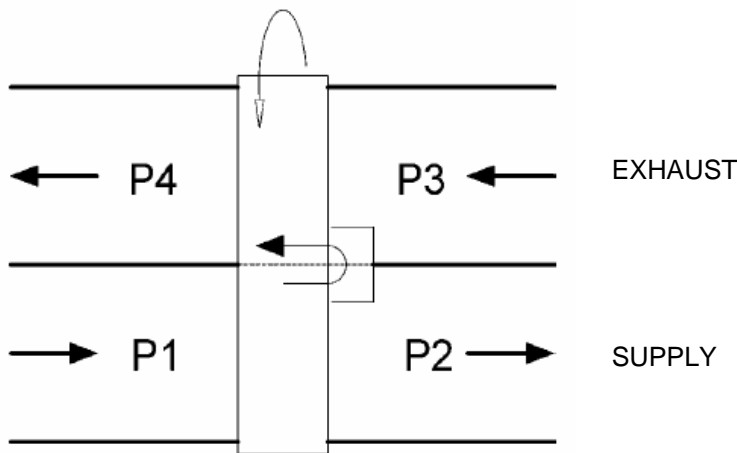

4.11 Units with burners

The unit fitted with a gas burner is placed in the overpressure part of the unit (supply side) so as to prevent the supply air and flue gases from mixing in case that the heat exchanger is damaged.

Parameters and settings for all parts of the unit fitted with a burner must be adjusted according to the burner manufacturer's instructions supplied together with the unit.

CAUTION : A burner must be connected to the gas piping and adjusted by a qualified person authorized by the burner manufacturer.

4.12 Compressors

CAUTION : All work on refrigeration systems should be carried out by an approved and qualified refrigeration service engineer..

NOTICE : Refrigerant circuit is vacuumed or filled with nitrogen. Before filling up with refrigerant, please check the pressure, make vacuuming the installation and filling with appropriate type and quantity of refrigerant.

Connect the compressor to power supply according to instructions on compressors naming plate or wiring schema. Check and connect other components of refrigeration circuit (magnetic valve, pressure gauges etc.).

4.13 Fan units

Prior to the commissioning the fan unit must be checked and the following operations performed:

- Remove reinforcing and fastening elements (needed during transportation of the unit, if mounted).
- Check the free fan wheel rotation without coming into contact with the fan casing.
- Check that the fan rotation direction corresponds to the rotation direction indicated on the fan casing.
- Check the free rotation of electric motor shaft.
- Clean the unit interior thoroughly and remove all free objects that might be sucked in by the fan.
- Check alignment of the pulleys and a proper belt tension.
- Check that flexible connections are properly fastened and by-passed by grounding tapes.
- Check that the motor feeder cable has been run to the motor connection box, moved sufficiently away from moving parts (fan wheel, motor, belt transmission) and properly fastened to the unit casing by lashings and clips.

 WARNING :	<p>WHILE SERVICE DOORS AND PANELS ARE DISMOUNTED FROM THE UNIT IT MAY BE OPERATED FOR A FEW MINUTES ONLY AND USED SOLELY FOR NECESSARY CHECKS. OPERATORS MUST PROCEED WITH UTMOST CAUTION SO AS TO PREVENT SMALL OBJECTS FROM BEING SUCKED IN AND PARTS OF THE BODY FROM GETTING CAUGHT BY MOVING PARTS OF THE UNIT.</p>
--	---

NOTICE :

Immediately upon completion of checking all the above-mentioned points, service doors and panels are to be closed.

4.14 Control switch-boxes and automatic control elements

- Check that the control switch-box is properly and firmly fixed on the wall.
- Check that the main feeder cable is properly connected to the control switch-box.
- Check that field equipment (sensors, electric motor drives etc.) is properly connected to the control switch-box and the DDC.
- Check that all electric cables are properly blanked off, properly run into elements and distinctly and visibly marked on both cable ends.
- Check the control switch-box for power supply.

5 COMMISSIONING

 **CAUTION :** The unit should be put into operation by a qualified person.

 **CAUTION :** The unit may only be started after it has been connected to the air ductwork and after all service doors and panels have been closed.

The initial commissioning is performed only once after the unit has been connected to the system and shall not exceed 30 minutes.

After the initial commissioning the unit is to be switched off and all unit components inspected. Special attention is to be paid to filters (dirt, mechanical damages), efficiency of the condensate drain system and to the fan unit (belt tension, fan and motor bearings temperature).

 **CAUTION :** When starting the unit, dampers on external unit connections are to be closed so as to avoid electric motor overload. After that it is to check that on reaching the electric motor operating speed the automatic control opens the dampers into the operating position .

The fan operating level has been set in accordance with the data indicated. After the unit has been started and the dampers opened it is necessary to check:

- the rated current drawn by the motor and
- the unit for vibration free operation with expected noise and with no unusual sounds.

If the air ductwork is carried out according to the design, it is necessary to balance airflow through air inlet and outlet openings. When the air volume flow rate reaches the value indicated in the design, the current draw of the electric motor must not exceed the rated current.

In case that the actual air volume flow rate lies below or exceeds the air flow volume designed, the electric motor belt transmission (adjustable pulley) should be adjusted or the pulley replaced, making sure that no electric motor overload is caused. The air volume flow rate is to be determined by means of approved measurement methods in conformity with ISO 5221.

NOTICE : The starting of the unit may, for a short time, be accompanied by a smell of burning coming from dust deposited on heating elements. If the smell persists check the functioning of heating elements (electric heaters, thermostats).

The final adjustment and determination of all values may be performed when the facility is completely equipped (furniture, plants, people), functional and balanced.

The antifreeze thermostat operation may only be checked when the temperature of air flowing to the heat exchanger lies below the thermostat setting. This can best be checked when the fresh air temperature is from +1°C to +2°C. Close the heating medium supply to the exchanger when the unit is running and observe whether the thermostat will turn on. The procedure described must be carried out before starting the unit for winter operation.

The commissioning of cooler-evaporator and testing and adjusting the operation of the cooling system external unit must be performed by a certified cooling equipment maintenance technician.

The burner starting must be performed by a qualified person authorized by the burner manufacturer.

5.1 CONTROL SWITCH-BOX

The control switch-box must be constantly supplied by the three-phase current of 3x400/230 V, 50 Hz. By turning on the main switch, Pos. 2, the necessary precondition for commissioning and operation of automatic control elements connected to the control switch-box and the DDC is fulfilled. Protective circuit breakers and motor switches must be in operating position.

While the unit is out of operation, the controller measures the ambient air temperature by a sensor and when this temperature reaches 0°C the controller will turn on the recirculation pump installed into the secondary heater circuit and open the heating valve.

The unit is started by pressing the controller, Pos. 6, and the following data appear on the display: temperature, operation mode, heater openness etc. (see a detailed description in the DDC instructions).

The error status may be read in the last two lines of the display, i.e. in Pos. 4 – at that moment the red light will turn on.

The control switch-box elements are shown in the illustration below :

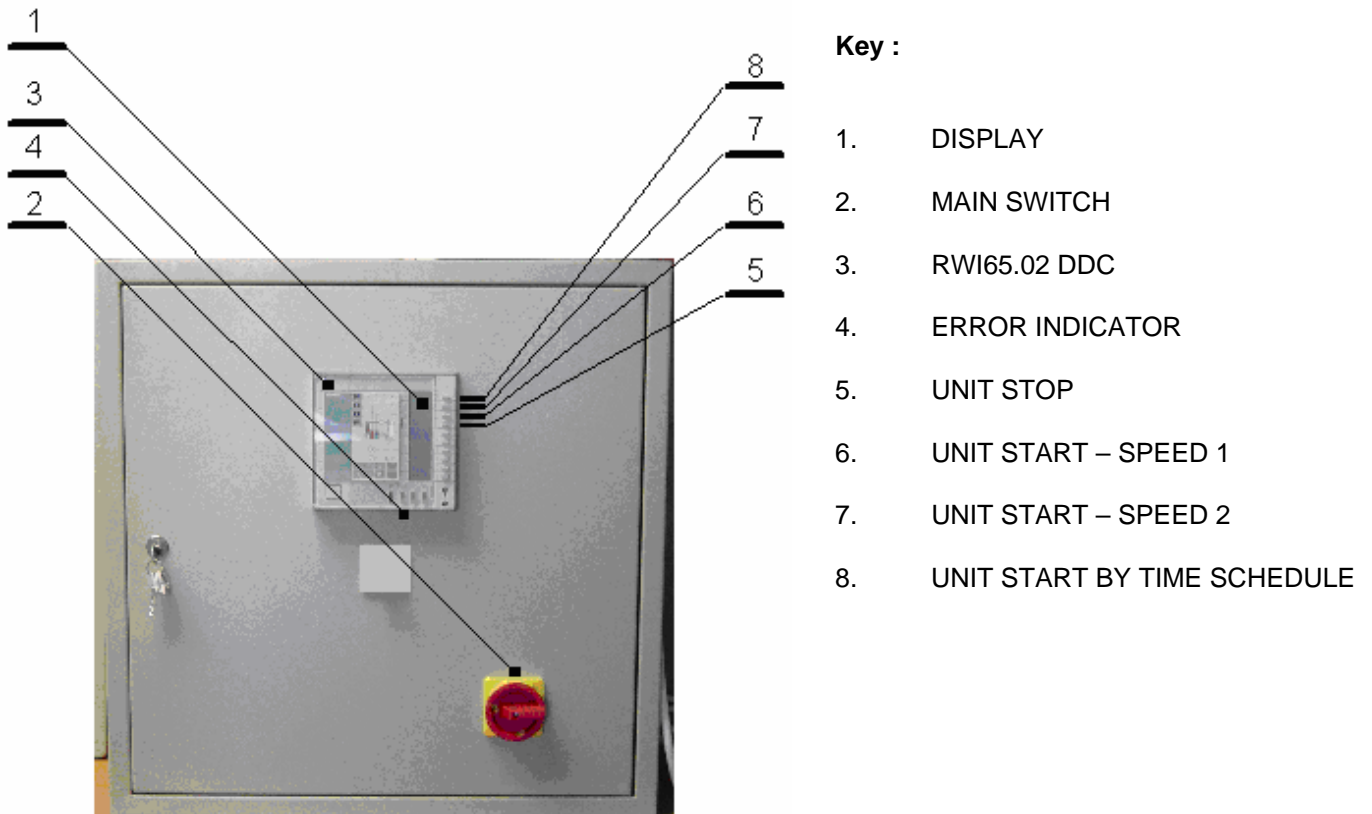

NOTICE : The control switch-box photo serves as an example only. The actual appearance and scope of control switch-box options may vary, depending on the unit configuration and the customer's order.

5.2 AUTOMATIC CONTROL ELEMENTS

Automatic control consists of field elements (sensors, valve drives, electric motor drives, etc.) factory fitted into the unit or supplied dismounted (packed separately) and a DDC.

5.2.1 FIELD ELEMENTS

NOTICE : Field elements are to be installed by a qualified person following the rules of profession, relevant standards, guidelines and regulations.

Elements supplied with the unit have been factory adjusted in accordance with the requirements specified in the design documents. Before commissioning it is necessary to check the elements for proper installation, the connections to the DDC and settings.

The field installation of elements is laid down by technical documents of the supplier of elements and is not a subject matter of these instructions. For these documents please you may refer to the nearest representative or dealer of the elements in question.

5.2.2 DDC REGULATOR

Operation instructions, options and a list of possible errors including instructions for their elimination relating to the DDC supplied and installed are supplied with the control switch-box.

6 UNIT MAINTENANCE – GENERAL

In order to ensure a smooth operation of the unit its components are to be periodically checked, cleaned and repaired, particularly those exposed to contamination (filters) or wear (bearings, belts).

NOTICE : The replacement of filters, belts and other consumables lies within the responsibility of the unit user. The costs of purchasing new components and of their replacement are to be borne by the unit user or owner.



CAUTION : Unit maintenance and repair are to be carried out by a qualified person authorized by the unit manufacturer.

The basic technical data about consumables and other important components may be found in the Spare Parts List that is supplied with the warranty and includes types, manufacture and dimensions of all important unit components (filters, heat exchangers, fans, motors).



WARNING : WHEN REPLACING OR CLEANING THE UNIT INTERIOR THE FAN UNIT IS TO BE SWITCHED OFF.

6.1 RECOMMENDED INSPECTION AND MAINTENANCE INTERVALS

All unit components are to be regularly washed by adequate cleaning agents causing no damage or corrosion.

NOTICE : The time schedule recommended below represents a framework recommendation of the unit manufacturer only and does not represent necessarily a rule for all methods of applying the unit. The check, cleaning and repair intervals are to be adjusted to actual needs, possibilities, regulations and the situation on site, as well as to the method and intensity of using the unit.

Description of activities	Recommended check intervals
Thorough visual inspection of the unit and built-in components	monthly
Minor internal cleaning	a month after the initial commissioning, afterwards each 3 (three) months
Checking the filter contamination	a month after the initial commissioning, afterwards each 3 (three) months
Checking other components	every 3 (three) months
General inspection and repair	every year

6.2 MAINTAINANCE OF UNITS IN HYGIENIC DESIGN

Air handling units of hygienic design (KU-H series) are developed specially for highly demanding ventilation and conditioning systems used in clean spaces such as hospitals, operating rooms, laboratories, pharmaceutical and electronic plants, etc.

The hygienic design of a unit differs from a standard design in the following points:

- The materials used are not harmful for human health and are not favourable for the growth of harmful microorganisms.
- Internal unit surfaces are made of materials highly resistant to tear and wear, cleaning and disinfecting.
- All air-conducting components are easily accessible for checking, cleaning and disinfecting operations.
- If the air-handling system has envisaged air humidification, the first air filter stage is constructed at least in class F6.

When repairing and cleaning air-handling units of a hygienic design special attention is to be given to the following:

- Usual cleaning and disinfecting agents in normal concentrations are to be used. Cleaning agents and disinfectants must not be aggressive, inflammable or toxic.
- Only good quality cloth and accessories causing no damage to the surface and leaving no hairs are to be used.
- Components that cannot be taken out of the unit (fans, motors, filters, exchangers, etc.) are to be carefully dismantled and pulled out by means of factory-mounted guide rails and mechanisms. After cleaning and disinfecting, check and remove the cloth and accessories from the unit, guide rails and mechanisms.
- All previously dismantled and cleaned components are to be re-fitted.
- All service doors and panels that were opened or removed to provide access to unit components are to be closed.

NOTICE : The units of a hygienic design must be maintained and cleaned by a qualified and well-trained person (B category according to VDI 6022, Part 2.).

For an efficient maintenance it is recommended to follow the instructions contained in the checklist attached and prepared in accordance with the VDI 6022 guideline, Part. 3. A maintenance logbook must be kept in accordance with the VDI 6022 guideline and other applicable regulations in force for this area.

6.3. CHECKLIST FOR OPERATION AND MAINTENANCE OF AIR-HANDLING UNITS OF A HYGIENIC DESIGN (ACCORDING TO VDI 6022)

	<i>Action</i>	<i>Measure to be taken if necessary</i>	<i>Interval months</i>	<i>Hygiene inspection</i>
1	Outside air inlets and air outlets			
1.1	Inspect for contamination	Clean and rectify	12	
1.2	Inspect for damage and corrosion	Clean and rectify	12	
2	Central air-handling units			
2.1	Inspect the air side for contamination, damage and corrosion	Clean and rectify	12	
2.2	Inspect for water formation	Clean, determine cause	6	
3	Air filter			
3.1	Inspect for impermissible contamination inc. Odours and damage (leaks)	Replace the defective air filter if the most recent filter stage replacement took place not more than 6 months ago, otherwise replace the complete filter stage	3	
3.2	Check the differential pressure	Replace the filter stage	1	
3.3	Latest filter change in case of non regenerative filters, otherwise through cleaning. First filter stage Second filter stage		12, 24	
3.4	Check the hygiene conditions			X
4	Air humidifiers			
4.1	Evaporation and recirculation spray humidifiers			
4.1.1	Inspect for contamination, damage and corrosion	Clean and rectify	1	
4.1.2	Check the bacterial count of the humidifier water (drip slides)	Where the bacterial count is >1000 KBE/ml, wash with cleaning agent, flush and dry the tank, disinfect if necessary	0.5	
4.1.3	Inspect atomiser nozzle for deposits	Clean or replace nozzles	1	
4.1.4	Inspect dirt traps for condition and functioning	Clean and rectify	6	
4.1.5	Check for flock formation at the bottom of the air humidifier tank	Clean tank	1	
4.1.6	Check the recirculation pump for dirt coating of the inlet pipe	Clean the pump circuit	1	
4.1.7	Carry out a functional test of blown down device	Readjust blow down device	6	

	<i>Action</i>	<i>Measure to be taken if necessary</i>	<i>Interval months</i>	<i>Hygiene inspection</i>
4.1.8	Carry out a functional test of conductivity measuring cell	Rectify	1	
4.1.9	Carry out functional test of sterilisation system	Rectify	1	
4.1.10	Clean the air humidifier if a shutdown of more than 48 hours occurs	Wash with cleaning agent, flush and dry the washer tank	As requested	
4.1.11	Check of hygiene condition			X
4.2	Droplet separator			
4.2.1	Inspect for contamination, damage and corrosion	Clean to maintain functioning	1	
4.2.2	Inspect the droplet separator for coating	Clean to maintain functioning where there is visible encrustation	1	
4.2.3	Checks of hygiene condition			X
4.3	Steam humidifier			
4.3.1	Inspect for contamination, damage and corrosion	Clean and rectify	3	
4.3.2	Wash with cleaning agent, flush and dry the humidifier chamber, disinfect if necessary		6	
4.3.3	Check for condensate precipitation in the humidifier chamber	Clean the vapor humidifier	1 (only during operation)	
4.3.4	Inspect the dirt traps for condition and functioning	Clean and rectify	6	
4.3.5	Check the vapour lance for deposits	Clean	6	
4.3.6	Check the condensate drain	Clean and rectify	3	
4.3.7	Functionally test control valve	Rectify	6	
4.3.8	Check of hygiene condition			X
5	Heat exchangers			
5.1	Inspect for contamination, damage and corrosion	Clean and rectify	3	
5.2	Inspect wet coolers, condensate tanks and droplet separators for contamination, corrosion and functioning	Rectify	3	
5.3	Functionally test the siphon	Rectify	3	
5.4	Clean wet cooler, droplet separator and condensate tank		6	
5.5	Check of hygiene condition			X
6	Fans			
6.1	Inspect for contamination, damage and corrosion	Clean and rectify	6	

	<i>Action</i>	<i>Measure to be taken if necessary</i>	<i>Interval months</i>	<i>Hygiene inspection</i>
6.2	Cleaning of parts of the fan in contact with air and also the water drain to maintain functioning		12	
6.3	Inspect the drive	Renew the belts	12	
6.4	Inspect the flexible connection	Renew the flexible connections if defect	12	
7	Heat recovery devices			
7.1	Inspect for contamination, damage and corrosion	Clean and rectify	3	
7.2	Check the seal between the incoming air and outgoing air	Rectify	3	
7.3	Inspect the condensate tank and droplet separator for contamination, corrosion and functioning	Rectify	3	
7.4	Functionally test the siphon	Rectify	3	
7.5	Clean the wet cooler, droplet separator and condensate tank		6	
7.6	Rotary wheel heat exchanger: Check correct pressure difference between supply and extract air		12	
7.7	Check the drive and the control system		12	
7.8	Check of hygiene condition			X
8	Air ducts and silencers			
8.1	Inspect accessible sections of the air duct for damage	Rectify	12	
8.2	Inspect the inside faces of air ducts for contamination and corrosion at 2 to 3 representative points	Determine cause, clean relevant section of air duct	12	
8.3	Inspect silencers for contamination, damage and corrosion	Rectify	12	
8.4	Check the hygiene conditions in the air duct at a representative point	Determine cause, clean relevant section of air duct		X
9	Air inlets			
9.1	Inspect installed perforated plates, wire mesh or sieves for contamination (random)	Clean and replace	12	
9.2	Replace filter pads in the case of :			
	filter class < F9		12	
	filter class ≥ F9		24	
9.3	Inspect air inlets which induct the room air and air outlets for the depositions of solids	Clean	As requested	
9.4	Clean the components through which the secondary air flows		12	
10	Cooling tower			
10.1	Inspect for damage and corrosion	Rectify	12	

	<i>Action</i>	<i>Measure to be taken if necessary</i>	<i>Interval months</i>	<i>Hygiene inspection</i>
10.2	Cleaning and draining the complete system		Twice yearly	
10.3	Check the blow down rate	Rectify	6	
10.4	Microbiological analysis of circulating water	Clean and disinfect	Twice yearly	
11	Dehumidifiers			
11.1	Inspect for contamination, damage and corrosion	Clean and rectify	3	
11.2	Inspect wet coolers, condensate tank and droplet separators for contamination, corrosion and functioning	Rectify	3	
11.3	Functionally test the siphon	Rectify	3	
11.4	Clean wet cooler, droplet separator and condensate tank		3	
11.5	Check of hygiene condition			X
12	Terminal devices			
12.1	Inspect terminal equipment with an outlet air filter for contamination	Replace the air filter, clean the equipment	3	
12.2	Inspect terminal equipment with a circulating air filter for contamination	Replace the air filter, clean the equipment	12	
12.3	Inspect the heat exchangers for dirt in the case of terminal equipment without air filters	Clean (vacuum cleaner)	6	
12.4	Clean the components through which the secondary air flows (without air filter)		12	
12.5	Replace air filter		24	
12.6	Do dampers work properly	Correct drive and position	24	
13	Cooling ceiling			
13.1	Inspect whether condensate does not appear		3	
13.2	Check the dew point sensors, control circuit inlet pipes and control valves for leaks	Rectify	12	
13.3	Check the expansion vessel		12	
14	Dampers			
14.1	Do dampers open and close correctly	Correct the positions of the blades	6	
14.2	Does the drive work properly	Correct the positions of the drive and of limit switches	12	

7 MAINTENANCE OF UNIT COMPONENTS

When maintaining and servicing the unit all below mentioned guidelines and recommendations, including special instructions supplied by manufacturers of individual components (electric motors, humidifiers, burners, etc.) must be followed.

7.1 Dampers

Damper blades, rubber seals, bearings, levers and frames are to be checked and held clean depending on the intensity of use and contamination of air flowing through the damper. When dirty, cleaning may be performed by means of an industrial vacuum cleaner or by blowing out by means of compressed air. If the results are not satisfactory, the damper is to be washed by water jetting with the addition of a usual aluminium-friendly washing agent.

Periodic maintenance includes lubrication of the connection between electric motor drive and the shaft, including the movable joint of two metal parts (control levers), by a graphite or lithium-based grease. Particular attention must be paid to lubrication if the air flowing across the joints mentioned has a de-greasing effect.

A general repair of the unit implies checking damper blades for the condition of rubber seals and especially for mechanical damage, dirt and functioning. If necessary, rubber is to be protected by anti-aging agents (glycerine) or replaced by a new one.

7.2 Filters

The filter unit maintenance implies the inspection for contamination of filter cartridges and their replacement, and checking the joints for tightness and filter units for a general cleanliness.

Metal filter cartridges may be washed by warm water containing a usual washing agent or by compressed vapour. In case that filter cartridges are damaged, they must be replaced by new ones.

Filters made of synthetic materials are to be replaced when they do not function properly (do not separate dust from airflow) or when instruments indicate that they are clogged (see the table below for final pressure drops allowed).

Filter class	Filter type	Final pressure drop
G2	metal filters	150 Pa
G3	panel/bag filters	250 Pa
G4	panel/bag filters	250 Pa
F5	bag filters	350 Pa
F6	bag filters	450 Pa
F7	bag filters	450 Pa
F9	bag filters	450 Pa
F6-F9	compact filters	450 Pa
H10-H14	absolute filters	600 Pa

NOTICE : It is recommended to replace filter cartridges made of synthetic material regularly each 12 months (in areas outside towns) or each 6 months respectively (in urban and industrial zones).

New filter cartridges must correspond fully to those original both in size and class. Each time when replacing a cartridge it is necessary to clean the filter unit interior and filter support frames.



CAUTION : The unit must not be operated without adequate filters. This may cause motor windings burnout due to overload.

In case of smaller units, filters are replaced laterally on the service side, by pulling out the support frame with filters installed. In case of larger units there is a service space provided in the unit interior in front of the filter and filter cartridges are pulled out from the filter support frame individually.

Each time when replacing filters special attention is to be paid to tightness. The number of filter cartridges, their type, manufacture and sizes are specified in the Spare Parts List supplied together with the warranty.

NOTICE : When replacing filters make sure that the unit is out of operation so as to prevent dust from entering into the unit.

7.3 Twin-coil heat exchangers – heaters and coolers

	WARNING : HOT PARTS. USE PERSONAL PROTECTIVE EQUIPMENT TO AVOID BURNS.
---	--

During operation twin-coil heat exchangers (heaters) must be fitted with an anti-freezing thermostat or charged with a non-freezing liquid mixture (e.g. water-ethylene-glycol mixture) in winter. If there is a risk of a temperature drop below +4°C during shutdown or idle period, water must be drained through the outlet connection on the bottom of the outlet header and lines must be blown through with compressed air to eliminate moisture residues.

 **CAUTION :** During operation make sure to prevent freezing of the medium in wet coolers.

Heat exchanger lamellas are to be checked to detect dust sediments, which impair its performance. Dust sediments may be removed by:

- vacuum cleaners,
- blowing compressed air in the direction contrary to the airflow through the unit and
- washing with warm water containing usual aluminium-friendly washing agents.

NOTICE : When washing wet coolers by compressed air or pressurized warm water take care to avoid mechanical damage.

NOTICE : During shutdown or idle period the heating medium flow must be reduced to minimum so as to prevent the temperature inside the unit from exceeding +60°C. The temperature rise above the value indicated may cause damage to certain unit components (motor, bearings, plastic elements, etc.).

Before washing the freon cooler lamellas with warm water freon should be sucked into the tank through a service connection on the wet cooler outlet header in order to avoid the unexpected freon pressure rise in tubes and damages to wet cooler tubes and connections.

NOTICE : Parameters of heat exchangers containing gas coolant (freon) are to be checked by a qualified person skilled at the assembly of cooling elements in accordance with the rules of refrigerating engineering.

Droplet eliminators are to be washed with warm water containing usual cleaning agents.

It is necessary to check the condensate drain system and the siphon condition and functioning.

7.4 Electric heaters

The electric heater condition is to be checked regularly, especially prior to the heating season. The check must include electrical connections and the functioning of safety units (thermostats, fuses, etc.).

	WARNING : RISK OF ELECTRIC SHOCK. DO NOT USE WATER FOR CLEANING. USE VACUUM CLEANER FOR REMOVING DUST AND DIRT.
---	---

NOTICE : Dust deposits must be removed, primarily before the heating time because the burning of dust deposited on electric heater rods gives off an unpleasant odour and may cause fire.

7.5 Spray humidifiers

The condition of spray humidifiers depends to a high degree on the method of treating water supplied to the humidifier. In order to reduce the concentration of minerals in the humidifier pan (by evaporation the air takes chemically clean water away) it is necessary to ensure regular water change. This is particularly important in case of a direct connection to the municipal water supply system without a water softener or a demineralizer respectively. Moisture, elevated temperature, oxygen content, sludge, scale and rust deposits in the system are favourable for the growth of micro-organisms, fungi and bacteria, which may cause numerous allergies and diseases.

Measures to be taken for the purpose of preventing and reducing the risk of microbial and fungi growth are:

- timely removal of sludge from the unit (once or twice a month);
- regular cleaning and disinfecting of the humidifier unit;
- use of softened feed water;

- application of mechanical and chemical sterilization agents;
- if the unit is idle for a long period of time (3-4 weeks or during the summer) the water tank must be drained, cleaned and dried and before restarting the unit the entire system must be flushed;
- feed water level in the humidifier pan is to be regularly checked and the float valve adjusted, if necessary;
- regular checks of the function and operation of recirculation pump and the fittings mounted;
- limit values of water quality indicators are to be monitored and compared to the values laid down in the VDI 3803 guideline.

The built-in UV-sterilizers are to be maintained in accordance with the UV-sterilizer manufacturers' instructions supplied with the unit.

	WARNING : RISK OF EYE DAMAGE OR SKIN BURNS. DISCONNECT UV-LAMP BEFORE SERVICE OR USE ADEQUATE PERSONAL PROTECTIVE EQUIPMENT.
--	--

7.6 Steam humidifiers

In case of steam humidifiers it is to check:

- proper operation and functioning of the steam power generator;
- proper operation and functioning of the vapour lance, steam supply line and condensate drain;
- fastening and functioning of lighting;
- feed water quality (hardness, microbiological quality) that must conform to regulations and guidelines VDI 3803 and
- tightness of vapour lance joints, steam supply lines and condensate drain on the unit casing.

Steam humidifiers are to be maintained and repaired in accordance with the steam humidifier manufacturer's instructions supplied with the unit.

	WARNING : HOT PARTS. USE PERSONAL PROTECTIVE EQUIPMENT TO AVOID BURNS.
--	--

7.7 Plate heat exchangers

It is necessary to check the condition of recuperator lamellas so as to detect dust deposits that impair its performance. The dust deposits may be removed by:

- vacuum cleaners,
- blowing compressed air in the direction contrary to the airflow through the unit and
- washing with warm water containing usual aluminium-friendly cleaning agents.

NOTICE : When cleaning plate and rotary wheel heat exchangers by compressed air or pressurized warm water take care to avoid mechanical damage.

It is also necessary to check the functioning of built-in (by-pass) dampers, condensate drain systems, the droplet eliminator and the siphon. They must be periodically washed with warm water containing usual cleaning agents. If the recuperator is used at temperatures below 0°C, lamellas are to be thoroughly dried before starting the unit.

If the recuperator is fitted with an antifreeze system it is necessary to check the functioning of built-in antifreeze elements.

NOTICE : When defrosting the recuperator lamellas, the by-pass damper is to be opened and when starting the unit, the by-pass damper is to be closed.

7.8 Rotary wheel heat exchangers

It is necessary to check the regenerator lamellas to detect dust deposits that impair its performance. The dust deposits may be removed by:

- vacuum cleaners,
- blowing compressed air in the direction contrary to the airflow through the unit and
- washing with warm water containing usual aluminium-friendly cleaning agents.

It is also necessary to check the functioning of built-in components (wheel speed control device including the motor and belt transmission) and remove dust deposits.

If the regenerator is used at temperatures below 0°C, lamellas are to be thoroughly dried before starting the unit.

Rotary wheel heat exchangers are to be maintained and repaired in accordance with the rotary wheel heat exchanger manufacturer's instructions supplied with the unit.

7.9 Units with burners

The built-in components and sections (by-pass dampers, valves, piping, thermostats, controllers, etc.) are to be checked for functioning and dust and soot deposits, which reduce the burner efficiency. Dust and soot deposits are to be regularly removed and a thorough cleaning is recommended immediately before the heating season (winter mode of operation).

Burners are to be maintained and repaired in accordance with the burner manufacturer's instructions supplied with the unit.

	DANGER :	RISK OF GAS EXPLOSION. DO NOT USE OPEN FLAMES IN VICINITY OF BURNER OR OTHER PRESSURE VESSELS.
---	-----------------	---

	WARNING :	HOT PARTS. USE PERSONAL PROTECTIVE EQUIPMENT TO AVOID BURNS.
---	------------------	---

7.10 Compressors

 **WARNING :** **DO NOT USE NAKED FLAME IF REFRIGERANT GAS IS PRESENT IN ANY APPRECIABLE QUANTITY IN THE LOCAL AREA..**

 **CAUTION :** Always ensure that the correct Personal protective equipment attire is worn.

NOTICE : Refrigeration systems contain gas at high pressure. Due care should be taken when connecting or disconnecting any component of gauge sets.

NOTICE : Do not release refrigerant to the atmosphere !! If adding or removing refrigerant is required, the service technician must comply with all national or local laws and regulations.

Always use refrigeration valve wrench to open or close service valves. Prior commissioning, check :

- is compressor properly connected to power supply
- magnetic valve is properly connected to power supply
- compressor anti-cycle timer is set to allow maximum 10 starts per hour
- installation is filled with refrigerant
- the suction and discharge pressures are set within operating limits
- regulating elements are properly installed

7.11 Fan units

The fan and electric motor mounted do not require any special maintenance and lubrication. However, periodic inspections of individual sections (fans, motors, belt transmission, shock-absorber and flexible connection on the fan discharge connection) are necessary, dust deposits that accumulate primarily on blade edges are to be removed and the fan wheel checked for an easy and quiet rotation. When cleaning a fan with a housing (wheel diameter >400 mm) a manhole is to be used.

The condition of bearings is checked by listening to the sound, which during normal operation must be a quiet buzzing. A scraping or a metal sound is an indication of damaged bearings that have to be replaced.

7.11.1 Belt transmissions

7.11.1.1 BELT TENSION

Belt tension must be regularly checked and adjusted. If the belt tension differs from the values indicated below the belt tension is to be adjusted by moving the motor by means of a belt tensioning screw located laterally on the electric motor base. Belt tension values are to be adjusted to the values indicated below. Over-tensioning causes overload, overheating and damage to bearings, and slack belts cause slippage and wear excessively.

NOTICE : Factory-adjusted belt tension must be checked after 50 hours of operation (only after the initial star-up). After that belt tension is to be checked periodically every 3 (three) months.

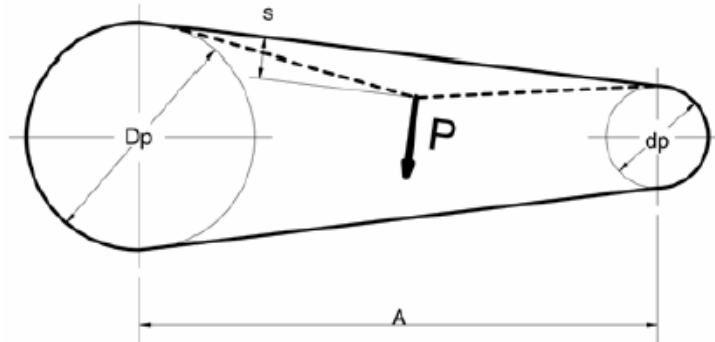

The recommended belt deflection force "P" for determination of belt tension depends on the pulley type and the smaller pulley dimension (dp) and may be calculated by the table below:

Belt type	Smaller pulley diameter range dp [mm]	Smaller pulley rpm range [min-1]	Belt tension force P [N]
SPZ	50 – 90	1200 – 5000	10 – 15
	100 – 150	900 – 1800	20 – 30
	155 – 180	600 – 1200	25 – 35
SPA	90 – 145	900 – 1800	25 – 35
	150 – 195	600 – 1200	30 – 45
	200 – 250	400 – 900	35 – 50
SPB	170 – 235	900 – 1800	35 – 45
	250 – 320	600 – 1500	40 – 60
	330 – 400	400 – 900	45 – 65
SPC	250 – 320	900 – 1800	70 – 100
	330 – 400	600 – 1200	80 – 115
	440 – 520	400 – 900	90 – 130

The recommended deflection "s" depends on the pulley type and the distance shaft to shaft (A) and may be calculated by the following formula:

$$s \text{ [mm]} = A \text{ [mm]} \times 1.5 / 100$$

Depending on the customer's requirement or the design, adjustable pulleys may be mounted, which may regulate the fan speed or rather the airflow to a certain extent. The pulley clearance is factory set.

The pulley opening clearance is adjusted manually by means of a setscrew in the pulley circumference (see the illustration). Dimensions of adjustable pulleys are shown in the table below :

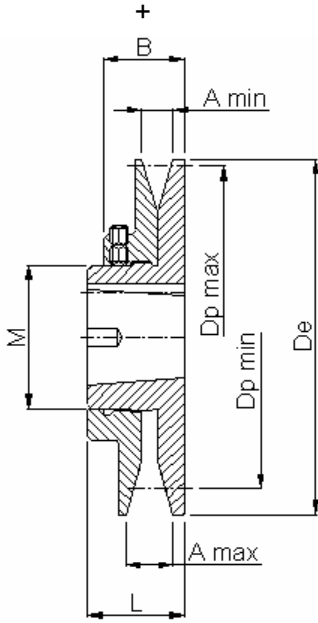
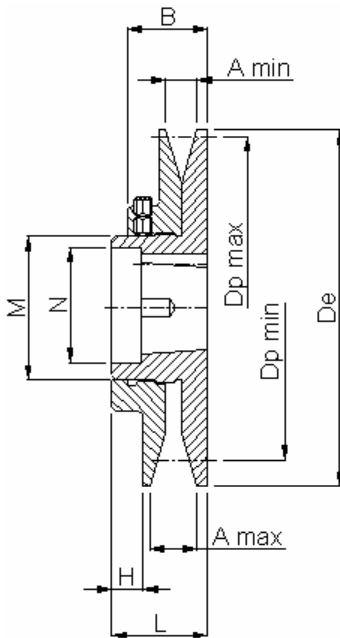
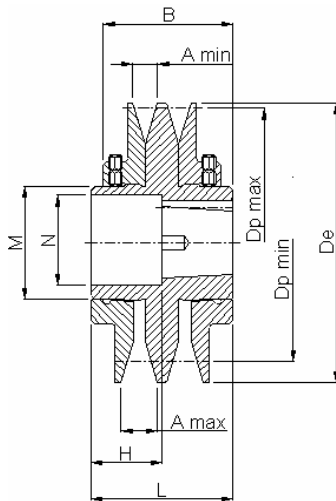
Version 1

Version 2

Version 3

Pulley type	Ver.	Profile	Diameter			De	L	φM	A		B	H	Ring
			Min	Sred	Max				Min	Max			
PR 1B 93	2	Z10x6	57	66	78	93	36,5	50	13	20,5	28,5	13,5	1108
		A13x8	59	74	85								
PR 1B 108	1	Z10x6	68	80	92	108	38	60	13	20,5	30,5		1215
		A13x8	70	85	100								
		SPZ	75	84	93								
		SPA	76	89	102								
PR 1B 120	1	Z10x6	80	92	104	120	38	60	13	20,5	30,5		1215
		A13x8	82	97	112								
		SPZ	87	96	105								
		SPA	88	101	114								
PR 1B 138	1	Z10x6	98	110	122	138	38	74	13	20,5	30,5		1615
		A13x8	100	115	130								
		SPZ	105	114	123								
		SPA	106	119	132								
PR 1B 160	2	A13x8	108	123	138	160	45	74	17	26,5	35,5	6,5	1615
		B17x11	112	131	150								
		SPA	114	127	140								
		SPB	117	135	153								
PR 1B 180	2	A13x8	128	143	158	180	45	90	17	26,5	35,5	12,5	2012
		B17x11	132	151	170								
		SPA	134	147	160								
		SPB	137	153	173								
PR 1B 200	2	A13x8	149	163	177	200	45	90	17	26,5	35,5	12,5	2012
		B17x11	152	171	190								
		SPA	155	167	179								
		SPB	159	176	193								
PR 1B 250	2	A13x8	199	213	226	250	48	108	17	26,5	38,5	3	2517
		B17x11	202	221	240								
		C22x14	204	220	236								
		SPA	205	217	229								
		SPB	209	226	243								
PR 2B 108	3	Z10x6	68	80	92	108	73	60	13	20,5	58	34,5	1215
		A13x8	70	85	100								
		SPZ	75	84	93								
		SPA	76	89	102								
PR 2B 120	3	Z10x6	80	92	104	120	73	60	13	20,5	58	34,5	1215
		A13x8	82	97	112								
		SPZ	87	96	105								
		SPA	88	101	114								
PR 2B 138	3	Z10x6	98	110	122	138	73	74	13	20,5	58	34,5	1615
		A13x8	100	115	130								
		SPZ	105	114	123								
		SPA	106	119	132								
PR 2B 160	3	A13x8	108	123	138	160	87	74	17	26,5	68	48,5	1615
		B17x11	112	131	150								
		SPA	114	127	140								
		SPB	117	135	153								
PR 2B 180	3	A13x8	128	143	158	180	87	90	17	26,5	68	54	2012
		B17x11	132	151	170								
		SPA	134	147	160								
		SPB	137	153	173								
PR 2B 200	3	A13x8	149	163	177	200	87	90	17	26,5	68	54	2012
		B17x11	152	171	190								
		SPA	155	167	179								
		SPB	159	176	193								
PR 2B 250	3	A13x8	199	213	226	250	93	108	17	26,5	74	47,5	2517
		B17x11	202	221	240								
		C22x14	204	220	236								
		SPA	205	217	229								
		SPB	209	226	243								

The dimensions and data indicated in the table are subject to alterations that may be made by the pulley supplier without previous notification.

7.11.1.2 BELT REPLACEMENT

In case that a belt is damaged it is necessary to replace all belts, of the drive, making sure that all of them are of equal dimensions and adequate cross-section that corresponds to the size of the pulley groove.

To ensure the purchase of matching pulleys needed for replacement, all data about the type and dimensions of factory-mounted pulleys are specified in the Spare Parts List accompanying the warranty.

In order to avoid damage during replacement, the electric motor setscrew on the side of the motor base is to be loosened (see the drawing), and the motor moved closer to the fan to make it possible to pull the used belts out and insert new belts in the grooves without applying force.

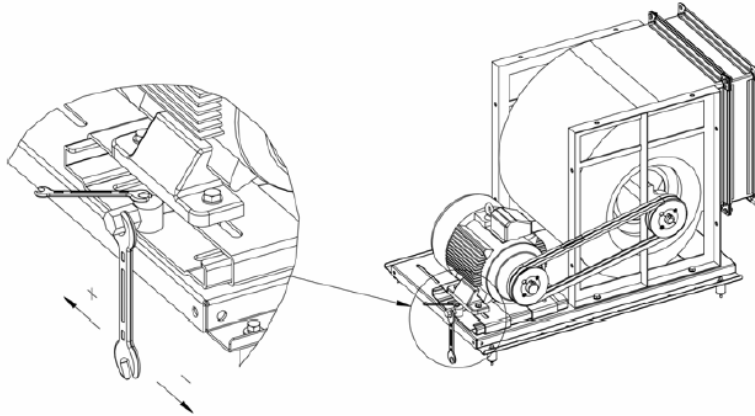

After that the belts are to be tightened making sure that pulleys are in alignment. If the belts are mounted correctly, the drive must rotate smoothly. Replaced belts are to be checked again after 50 hours of operation.



CORRECTLY

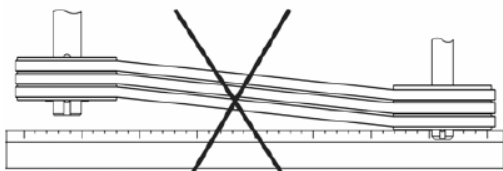

INCORRECTLY

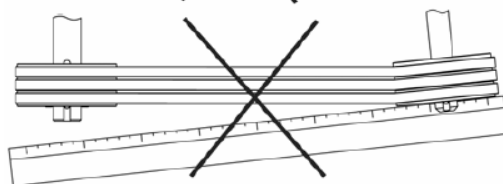

7.11.1.3 PULLEY REPLACEMENT

Periodic checking of pulleys for their condition, functioning, grooves, setscrews and other moving parts is necessary.

When moving the pulley for the purpose of alignment or replacement use the following procedure:

- degrease and clean all surfaces (shafts, holes, threads, etc.);
- slide the pulley on the motor shaft and insert the taper lock sleeve;
- turn the pulley until holes on the pulley are in line with holes on the taper lock sleeve;
- insert screws into the holes and tighten them in place making allowance for endplay of the pulley;
- align the electric motor shaft and the fan shaft;
- adjust the alignment of pulleys (horizontally and vertically);
- tighten the screws by a torque wrench (according to the table enclosed)

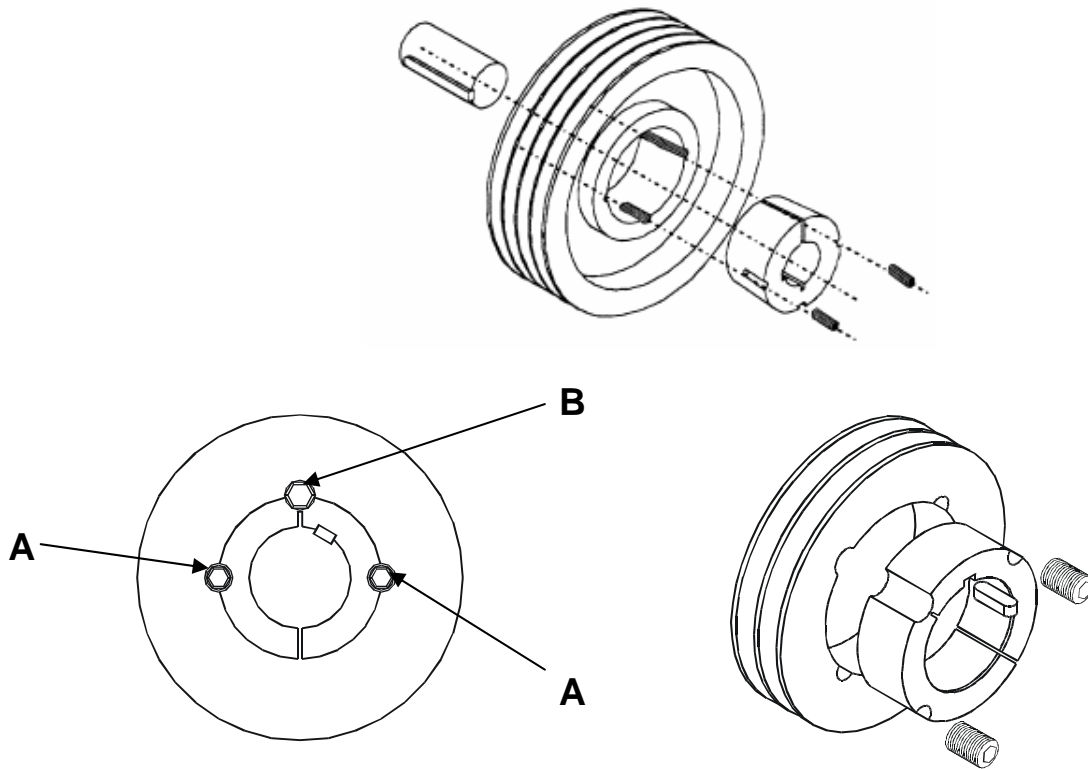

NOTICE :

When mounting a pulley, first insert the screws in "A" holes and when dismantling the pulley, the "B" screws are to be taken out as first.

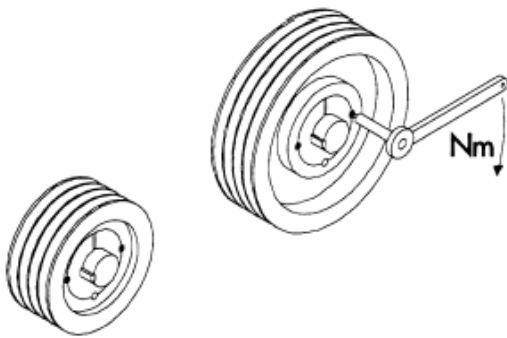

Locking ring type	Screw torque values (Nm)	Screw	
		Qty.	Size
1008	5,6	2	1/4"
1108			
1310	20	2	3/8"
1315			
1210	20	2	3/8"
1215			
1610	20	2	3/8"
1615			
2012	31	2	7/16"
2517	48	2	1/2"
3020	90	2	5/8"
3030			
3535	112	3	1/2"
4040	170	3	5/8"
4545	192	3	3/4"
5050	271	3	7/8"

The deviation of inclination of the pulley against the horizontal axis must not exceed 0.5°.

To ensure the purchase of matching pulleys needed for replacement, all data about the type and dimensions of factory-mounted pulleys are specified in the Spare Parts List accompanying the warranty.

7.11.2 CHECKING, LUBRICATION AND REPLACEMENT OF BEARINGS

The majority of bearings mounted in individual sections are self-lubricating and pre-lubricated for the entire lifetime. It is recommended to check the condition of bearings by listening to the sound they produce during operation. For this purpose put a screwdriver on the bearing housing and listen to the sound. If the sound is quiet and buzzing, the bearing operates properly. Otherwise, the noise produced by bearings indicates the lack of grease. When a metal sound like banging is heard, the bearing is damaged and must be replaced.

Most of the bearings (depending on the type and manufacturer) may be lubricated by means of grease fittings located on the bearing housing. Bearings are lubricated by grease at intervals that vary with the intensity of the unit operation and the condition of bearings. For the grease type it is to refer to the bearing manufacturer's catalogue. It is recommended to lubricate bearings once a year (if the unit is run 8 hours a day) or twice a year (if the unit is run most part of the day). The application of grease causes a slight heating of the bearing housing, especially at high motor or fan shaft speeds. After several lubrications it is recommended to open the bearing and remove the used grease before applying the new.

To ensure the purchase of matching bearings needed for replacement, all data about the type and dimensions of factory-mounted bearings are specified in the Spare Parts List accompanying the warranty.

When a bearing must be replaced, remove the belts and the pulley from the shaft where the bearing is located and support the shaft on the side where the replacement will take place. The bearing must be replaced by the identical one or by another manufacturer's bearing of matching characteristics. To avoid possible vibrations and resonance it is recommended to replace both bearings at the same time.

7.11.3 MOTORS

It is necessary to check the functioning and fastening of the motor and to inspect the bearings. Dust deposits on the housing are to be cleaned without using water.

After servicing, the fan wheel rotation direction must be checked (it must correspond to the direction indicated on the fan casing). If the rotation direction has changed, this may be a result of e.g. changed polarity of the power network. Therefore it is advisable to check the fan wheel rotation direction.

7.11.4 PLUG FANS

Air-handling units of a hygienic design are mostly fitted with fans without a casing (plug fans).

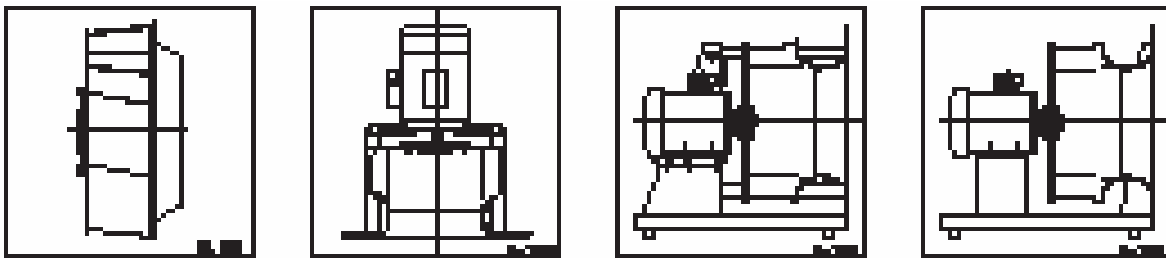

7.11.4.1 Application

Centrifugal impellers without scroll (plug fans) are not ready to use products, but designed as components for air-conditioning, air supply and air extraction installations. They may only be operated when they are installed as intended, and when safety is ensured by safety equipment according to DIN EN 294.

7.11.4.2 Safety information

- The Operating Instructions are part of the product and have to be kept carefully.
- The impellers are only intended for the transfer of air or air-like mixtures. They cannot be used in hazardous areas for the transfer of gas, mist, vapours or mixtures. Nor can they be used for the transfer of solids, or solid components in the transfer medium.
- Only operate the fan according to the intended application, and only up to the maximum permissible speed given in the information on the fan/impeller rating plate. Exceeding the maximum permissible speed leads, as a result of the high kinetic energy (mass x rotation rate), to a hazard situation.

- The impeller can disintegrate -lethal hazard! The maximum permissible operating data given on the rating plate are valid from air density $\rho = 1.2 \text{ kg/m}^3$.
- When using a frequency converter to control the speed care should be taken to ensure that the maximum permissible speed cannot be exceeded if there is a fault in the frequency converter.
- Mounting, electrical connection and commissioning may only be carried out by trained specialized personnel who observe the relevant regulations!
- When using motors without temperature monitors, it is imperative to use a motor circuit breaker.
- Observe the installation and safety information for the various fan types. Non-observation or misuse can lead to physical injury or damage to the fan or installation.
- Observe the notes in the motor manufacturer's operating instructions, which form part of the supply.
- If the fan is installed for free-running intake or exhaust, please check to see whether the safety standards of DIN EN 294 are observed. Objects sucked in can be thrown out by centrifugal force and lead to damage or severe injury.
- Ensure that on the suction side is enough safety distance because of the suction of the fan clothes, limbs or by greater fans also persons can be taken in.
- It is not possible to exclude a residual risk due to incorrect use, malfunction or force majeure. The designer or constructor of the installation must take suitable safety measures in accordance with DIN EN 292, e.g. protection devices, in order to prevent hazardous situations arising.

7.11.4.3 Transport, storage

NOTICE : Arrange the load spreader transverse to the motor axle. Ensure that the load spreader is sufficiently wide.

Chain or cable must not touch the fan impeller during lifting! On no account stand under the swinging fan, since life can be at risk in the event of a defect in the transporter. Make sure that the weight information on the fan rating plate and the permissible loads of the transporter are always observed.

- Avoid blows and shocks.
- In the event of damage inform the carrying agent immediately.
- Store the fan in a dry, dust- and vibration-free environment.
- Avoid excessive storage times. Please refer to the manufacturer's motor information on this.

7.11.4.4 Installing the impeller

Impellers with fixed hub

The impeller is connected to the shaft end of the drive motor using a fixed hub.

- Installation: Lightly lubricate all bare surfaces (shaft ends, hub holes). Pull the impeller with the hub up to the shaft shoulder (transitional fit). Secure with the hoisting device with corresponding weight. Secure the axial shaft locking device using the screw and washer with Loc-tite. Maintain torques in accordance with data from fan manufacturer's operating instructions.
- Disassembly: Release the axial screw connection and pull off the impeller with the hub using a suitable pulling unit (secure with hoisting device at the corresponding weight)

Impellers with taperlock clamping bush hub:

The impeller is fitted to the end of the motor shaft using taperlock spring collets.

Mounting:

- Clean all bare surfaces (locating surfaces of the taperlock spring collets and motor shaft) and degrease them.
- Push the taper lock spring collet into the root and make the holes coincide. Oil set-screws lightly and screw in - do not tighten yet.
- Push the impeller with taper lock spring collet onto the shaft without loading it (using a hoist if the impeller weight requires it), align the axial position and tighten the set-screws symmetrically. Observe the tightening torque given in the fan manufacturer's operating instructions. Fill empty holes with grease, to prevent the penetration of foreign bodies. After approximately 1 hour of running time, check the tightening torque of the screws for the value required.
- Removal:
 - Loosen all set-screws, depending on the size of the collet, unscrew one or two set-screws completely, oil them and screw them into the removal holes. Pull on one or both set-screws, until the collet comes free of the root. The impeller can now be taken off.

7.11.4.5 Setting up the unit

- Observe the safety information!
- In order to avoid transmitting disturbing vibrations, it is recommended that a means of decoupling the structure borne noise of the complete built-in fan should be used. (Spring or attenuation components are not part of the standard supply). The allocation of the distance between the spring suspensions, depending on whether the fan is fitted with accessories or not, can be found on fan manufacturer's operating instructions

NOTICE : All contact points must be fixed securely to the base. If the fixing is inadequate there is a risk of the fan overturning.

- Ensure adequate clearance on suction and pressure sides.
- Erect in the open air only if this is expressly mentioned and confirmed in the ordering information. There is a risk of damage to the bearings if the fan remains stopped in a moist environment. Avoid corrosion by suitable protective measures. Roofing is required.
- Modifications/conversions to the fan undertaken by the operator are not permissible - safety hazard.

Electrical connections

- May only be undertaken by technically trained personnel (DIN EN 50 110, IEC 364).
- Ensure that attention is paid to the motor manufacturer's safety and commissioning information and the circuit diagrams in the motor terminal box.
- Before making the electrical connections to the motor compare the connection data with the information on the motor rating label.

7.11.4.6 Operating conditions

- Do not operate the fan in atmospheres with risk of explosion - danger of sparking, - danger of explosion.
- Observe the motor manufacturer's instructions.
- Do not exceed the maximum operating speed (fan/impeller rating plate), see the safety notes. The maximum permissible operational revolution speed applies for sustained operation S1. Increased switching repetitions only permissible with gentle step-up by means of frequency converter or with operation without frequency converter by means of Y/D circuit.
- Do not operate the fan in the resonance range of the impeller - risk of fatigue fracture. When changing the speed, pass rapidly through the resonance range.

7.11.4.7 Operation / Test operation

- Before commencing operation, test that:
 - Account has been taken of the motor manufacturer's information?
 - Installation and electrical connections have been completed properly?
 - Any residual materials from mounting and other foreign bodies have been removed from the impeller and the suction area.
 - The motor protection is correctly set?

With a Y/D connection, switch-on current should be set at 58% of the rated value, if the phase current is fed through the motor protection. I.e. do not connect the motor protection in the mains lead before the switchgear, but between motor terminals U1, V1, W1.

- Does the type of rotor balance (of the motor and impeller) DIN ISO 8821 match each other?

• The impeller should be checked for mechanical oscillations after in-stallation.

If the amount of fan oscillation is larger than 2.8 mm/s, (measured on the end plate of the impeller side of the motorbearing), the motor/impeller unit must be examined by specialists and, if necessary, rebalanced.

- Initial commissioning should only occur, when all the safety information (DIN EN 50 110, IEC 364) has been checked.

The impeller is not within physical range (DIN EN 294) and hazards due to e.g. sucking in of clothing, limbs or people has been excluded, see safety information.

- Check the current consumption! If the current consumption is higher than that stated on the motor rating plate, the fan must be disconnected immediately.

- Check the direction of rotation (the rotation direction arrow is on the impeller base plate or on the fan housing)

- Ensure quiet low-vibration running.

-Find the impeller resonance range. If the resonance range is within the working range, set the frequency converter in such a way that the resonance range will be passed through rapidly. Strong vibrations resulting from irregular running (imbalance), due, for example, to damage in transport, in correct handling or operation within the resonance range can lead to failure.



CAUTION : Do not run the fan in the breakdown.

Operation in the unstable region leads to damage to the fan (risk of fatigue fracture).

- frequently commissioning an shutdown of the Impeller must be avoided (please ask the supplier)

7.11.4.8 Repairs and maintenance

- The fan should be checked for mechanical oscillations in accordance with VDI 2056 every 12 months. The maximum permissible oscillation intensity is 2.8 mm/s (measured at the motor bearing impeller side).
- Depending on the use and the medium in which it operates, the impeller and housing are subject to normal wear. Deposits on the impeller can lead to imbalance and hence to damage (risk of fatigue fracture)
 - the impeller can disintegrate - lethal hazard!
 - Regular inspection with cleaning is absolutely essential.
 - Observe the motor manufacturer's instructions on repairs and maintenance.
 - The maintenance interval depends on the level of contamination. Check the impeller, in particular the weld-seams, for possible cracks.
- Repairs should only be carried out by trained personnel (electrical fitters).
- In all repair and maintenance work observe the safety regulations (DIN EN 50 110, IEC 364):
- Ensure the fan impeller is stationary!
 - The electrical circuit must be disconnected and protected against inadvertent reconnection.
 - When operating by means of frequency converter, ensure that the waiting time is maintained after safety disconnection – see manufacturer's operating instructions regarding capacitor discharge time.



WARNING :

NO MAINTENANCE OPERATIONS ON THE FAN WHILE RUNNING!

- Follow working instructions (DIN EN 50 110, IEC 364).
- Running fans must not be washed down by high pressure cleaners (steam jet)!
- Wet cleaning under voltage can lead to electric shock - lethal hazard!
- Keep the air passages of the fan clear - risk from flying objects!
- Attend to untypical running noise!
- Replacement of bearings in accordance with the motor manufacturer's instructions. If required ask for additional operating instructions.

Plug fans are manufactured in compliance with applicable international standards and regulations.

The maintenance and repair of fans without a casing are to be carried out in accordance with the manufacturer's instructions attached to the unit.

7.12 CONTROL SWITCH-BOXES

From time to time connections are to be retightened to reduce possible sparking and functional tests are to be carried out. Dust deposits are to be removed by cloth or brushes without using water.

7.13 OTHER COMPONENTS OF THE UNIT

Other components of the unit (mixing sections, sound attenuators, automatic control elements, etc.) do not require any special maintenance. However, regular checks of the general condition of these components, tightness of connections, contamination, functionality, wear and fastening are necessary.



CAUTION :

In case of uncertainty considering proper maintenance, please check for additional instructions (if available) or contact manufacturer before starting repairs.

8 HANDLING WITH ATEX UNITS

Units marked with the Ex mark (referred as ATEX units) are suited for use in accordance with the ATEX directive, Directive 94/9/EC, in the specified explosion hazard areas as marked on their nameplate and in their technical data sheet. Be sure to observe any restrictions on use.

The ATEX unit is designed according to the restrictions on use given by the customer. The air handling unit is a single component and cannot guarantee by itself the complete and comprehensive explosion protection. The protection concept concerns the whole plant. The overall responsibility for the explosion protection rests for the user respectively plant constructor.

Scope of usage

ATEX units must not be used near:

- High-frequency sources (e.g. transmitters)
- Strong light sources (e.g. lasers)
- Ionizing radiation sources (e.g. X-ray tubes)
- Ultrasound sources (e.g. ultrasound echo testing equipment)

Commissioning

Do not commission ATEX units until the following requirements are met:

- Conditions of use in accordance with the purpose for which the unit is intended.
- No substances nearby that are prone to spontaneous combustion (pyrophoric substances) under EN 1127-1.
- Constant and adequate ventilation of the installation site (control room) in the case of ATEX units without a specified exterior ex zone so that unavoidable leakage to the exterior of the unit does not result in an explosive atmosphere.

Service and maintenance

Suitable tools in accordance with EN 1127-1 must be used to prevent sparks etc. when performing maintenance and cleaning work in explosion hazard zones. Conductive footwear in accordance with BGR 132 must be worn to prevent personnel from accumulating static charge.

NOTICE : *To prevent danger of ignition due to electrostatic charge, all surfaces of ATEX units must only be cleaned with a damp cloth.*

Only qualified personnel is allowed to carry out changes at the air handling unit. After conducting changes (i.e. installation of spare parts) it has to be executed a reconfirmation according to the safety and health requirements of the ATEX-guideline by qualified personnel.

- Check all elements for hygiene, fouling, damage, corrosion and fastening.
- Check bearings for vibrations, heating and noise. Grease bearings according to bearings manufacturer specification.
- Check belt drive for fouling, damage, wear, tension, alignment of motor and fan pulley (tolerance < 0.4°; i.e. < 7 mm/m), function and fastening (see locking torques).
- Clean, adjust, replace, tighten belt drive regularly or after fitting.
- Check protective device for damage, fastening and functioning.
- Check flexible coupling for leaks.

Check ATEX units regularly (once a month).

Spare parts and repairs

The reconfirmation has to be documented and executed before restarting the unit. Spare parts has to be correspond with the specific requirements of the applied ATEX-graduation (category, atmosphere, class of temperature). Use preferably identical original components.

The ATEX EC-declaration of conformity from PRO-KLIMA expires by improperly changes of the unit by the Third party.

9 SWITCHING OFF AND LONG SHUTDOWN PERIODS

The unit may only be switched off by power supply main switch or by means of the automatic control system located in the control switch-box.

For the purpose of maintenance or repair the unit may be switched off for a short period of time by disconnecting the main power supply of the fan by means of a service switch (if mounted). The service switch is to be mounted on the fan unit.

In case of a longer shutdown of the unit care must be taken to prevent the freezing of medium in heat exchanger tubes and to allow the condensate accumulated in condensate pans to be freely discharged into the sewerage system.

After a longer shutdown of the unit and before its re-starting the condition of the casing, inlet and outlet openings, built-in components, their cleanliness and functioning are to be checked.

Re-starting of the unit is to be performed in accordance with the instructions in Chapter 4.

10 CHECK MEASUREMENTS

During regular inspection and maintenance operations all operating parameters of the unit are to be checked, which includes:

- measuring temperature and humidity in front of and behind the unit component used for air treatment which implies changes in temperature or humidity parameters;
- measuring temperature and other operating parameters of the heating and cooling medium;
- measuring the total pressure drop on the fan and
- measuring the rated current of all power consuming devices.

In compliance with the legislation and regulations it is necessary to keep corresponding maintenance records or rather maintenance logs.

11 INFORMATION

Periodical checks of the entire unit carried out by qualified and competent maintenance and service personnel authorized and trained by PROKLIMA as the manufacturer of the unit guarantee many years of a reliable operation of the unit without shutdowns and defects. Our personnel is ready to assemble the unit supplied disassembled, to install the unit on the site, to put the unit into operation and carry out servicing, and is available to promptly provide assistance in emergency cases at any time and in any part of the country.

All data about the authorized servicing companies may be obtained from the manufacturer or you may refer to the manufacturer's website at www.proklima.hr.

For all additional instructions and assistance in troubleshooting do not hesitate to contact the manufacturer's personnel (phone no. +385 1/6546-343; fax no. +385 1/6546-344; e-mail: support@proklima.hr). We are always at your disposal.

DECLARATION OF INCORPORATION AND INFORMATION FOR SAFE INSTALLATION, OPERATION AND MAINTENANCE

Manufacture :

PRO-KLIMA d.o.o., Talani 14, HR-10000 Zagreb, Croatia

declare that the machinery named below is intended to be assembled with other components to constitute a system of machinery. The machinery shall not be put into service until the system has been declared to be in conformity with the provisions of the EC Council Machinery Directive, Annex II A.

Designation of machinery :	Air handling unit
Machinery Types :	KU 1 – KU 24
Relevant EC Council Directives :	98/37/EC (Machinery Directive)
Applied Harmonised Standards :	EN 12100-1 und EN 12100-2; EN 60 204-1

Signature of manufacture representative:

Date : 25.04.2007.

General Manager

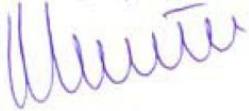

Nikola Rukavina



DECLARATION OF CONFORMITY

Manufacture :

PRO-KLIMA d.o.o., Talani 14, HR-10000 Zagreb, Croatia

declare that the machinery named below conforms to the requirements of EC Council Machinery Directive, Annex II B.

Designation of machinery :	Air handling unit
Machinery Types :	KU 1 – KU 24
Relevant EC Council Directives :	98/37/EC (Machinery Directive)
Applied Harmonised Standards :	EN 12100-1 und EN 12100-2; EN 60 204-1

Signature of manufacture representative:

Date : 25.04.2007.

General Manager

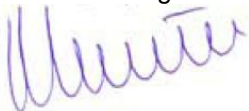

Nikola Rukavina

NOTES :

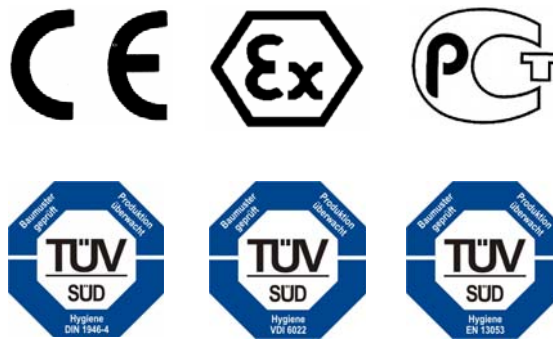

Manufacture of Ventilation, Air-conditioning and Hot Air Heating Equipment

Head : Talani 14, HR-10000 Zagreb, Hrvatska
Office and factory : Gradna 78E, HR-10430 Samobor
Phone: +385 1 / 6546-343
Fax: +385 1 / 6546 - 344
Email: proklima@proklima.hr
Internet: www.proklima.hr