

CONTENT

1.	Manufacturer	1
2.	General safety informations	1
3.	Purpose	2
4.	Product compliance	2
5.	Degree of protection and technical data	2
6.	Type	3
7.	Mounting and installation	3
8.	Dimensions	6
9.	Spare part and accessories	6
10.	Inspection, maintenance, repair and overhaul	6
11.	Responsibility and authorization	7
12.	Storage and transport	7
13.	Manufacturer's transport	7
14.	Marking	7

1. MANUFACTURER

TEP Ex d.o.o.
Prilaz dr. Franje Tuđmana 6 HR-49210 ZABOK
Tel: +385 49 222 900
Web: www.tepex.hr

2. GENERAL SAFETY INFORMATIONS**WARNING !**

The user manual contains basic information about the product. Mounting, installation, usage and maintenance should be carried out under this user manual to provide and ensure safe operation within the nominal characteristics. This user manual complement national Regulation and Standards. The responsible person shall ensure their implementation. Failure off implement this user manual can reduce explosion protection and endanger people, property and the environment. Any improper and illegal actions as well as non-compliance with the provisions of this user manual excludes all responsibility by manufacturer side.

Before installation/commissioning:

- Carefully read all instructions,
- Execute proper training of responsible personnel,
- Check that the contents of these instructions is fully understandable by the responsible personnel,
- Make sure that all the requirements and national Regulations as well as all special security measures are applied.

In lack of understanding:

- Contact the manufacturer.

During operation:

- Ensure that this user manual and other work instructions are available to the responsible staff at all times,
- Check the implementation of these instructions and all other safety user's instructions

3. PURPOSE

Explosion proof fluorescent lighting fitting type PSF 236 is intended for use in industrial areas endangered explosive atmosphere, in Zones 1,2 and in areas endangered by explosive and flammable mixtures of dust and air in Zones 21, 22 accordance with EN 60079-10-1/-2: 2009.

Ex fluorescent light fitting is used as fluorescent lighting fitting with two T8 (Ø26mm), 36W – 2G13, fluorescent lamp in parallel configuration.

4. PRODUCT COMPLIANCE

The product is in compliance with Regulations concerning equipment and protective systems for use in potentially explosive atmosphere, NN br. 34/10.

The product complies with the ATEX Directive 94/9 EC and standards:

- EN 60079-0:2012,
- EN 60079-1:2007,
- EN 60079-7:2007,
- EN 60079-18:2009,
- EN 60079-31:2009.



The product has been developed, manufactured and tested according to the existing state of technique accordance with the standards EN 9001:2008 and EN ISO / IEC 80079-34:2011.

The product is in compliance with the LV Directive 2006/95 EC.

The product is in compliance with the RoHS Directive 2002/95 EC.

The product is in compliance with EMC Directive 2004/108 EC.

5. DEGREE OF PROTECTION AND DATA

Certificate:	EXA 13 ATEX 0014
Marking:	
Category and explosion protection:	 II 2G Ex d e mb IIC T4 Gb II 2D Ex tb IIC T80°C Db
Ambient temperature:	$-20^{\circ}\text{C} \leq T_a \leq +50^{\circ}\text{C}$
Mechanical protection:	IP 66
Resistance to shock:	IK 08
Class of protection:	I (PE - protective earthing)
Rated voltage:	220-240 V ($\pm 10\%$)
Frequency:	50/60 Hz
Rated current:	0,33 A
Power factor:	$\lambda=0,95$
Ballast lumen factor BLF:	97,5%
End of life EOL:	The electronic ballast, type SMP 07/12 fulfills the requirements according to EN 61347-2-3:2011 (simulation of the "end of life effect" of fluorescent lamps)
Lifetime of ballast:	70.000 hours at $T_{amb} = 40^{\circ}\text{C}$
Lifetime of lighting source:	medium, 10,000 hours (long tube lifetime up to 70,000 hours, only on special request)
Light source:	fluorescent tube, 36W, T8-Ø26 mm, according to EN 60081:2008+A4:2012
Lampholder:	G13 accordance EN 60061-1:2008+A45:2012
Cable entry:	Two cable glands Ex e M25x1,5, for cable diameters Ø6-15 mm and two Ex e plug in accordance with EN 62444:2013
Through wiring:	3 x 2,5 mm ² , max. 16 A, or looping of the cables (entry and exit on one side)
Central interlocking switch (no-load condition)	When the central interlocking switch is in position "OPEN" internal elements of the lamps are in no-load condition (electronic control gear, head of G13 ...). The interlocking switches power on a flashlight after closing the cover and rotate the lock switch in position "CLOSE". In case of failure or lack of one of the fluorescent tubes, electronic control gear type SMP 07/12 shuts off the power to the malfunctioned fluorescent tubes.

Maximum number of lamps (pieces) per one automatic circuit breaker:	Automatic circuit breaker			
	1p B 10A	1p C 10A	1p B 16A	1p C 16A
	10	16	16	28
Housing:	SMC, polyester plastic reinforced with glass fiber, color RAL 7038			
Diffuser:	PC, polycarbonate plastic			
Tightening torque:	<ul style="list-style-type: none"> - pressure screw – 2,5 Nm - intermediate gland and plug – 3,5 Nm - plug in housing – 4 Nm - screw terminals – 0,5 Nm 			
Isolation stripping length of the connection wires:	9 mm			
Dimension:	1370 x 200 x 130 (L x W x H)			
Weight:	10 kg			

6. TYPE

MODEL CODE	WATAGE	LAMP TYPE	NOMINAL VOLTAGE	LUMINOUS FLUY [lm]	LAMP HOLDER	NOMINAL OPERATIONAL CURRENT	WEIGHT
PSF 236	2x36 W	T8	220 - 240 V	2 x 3350	G13	0,33 A	10 kg

7. MOUNTING AND INSTALATION

Fluorescent lighting fitting comes standard with fluorescent tubes, special wrench for open the lid, two Ex-e cable glands M25 (for cable 6-15mm), two Ex-e plug M25 and accessories for suspension assembly (PSF 30-150).
The lamp is designed for indoor and outdoor use.

Notes for safe installation and assembly:

- Check the ambient temperature
- Possibility of installation in hazardous areas 1, 2, 21, 22
- Checking of cable entry into the fluorescent lighting fitting (compromised mechanical protection, IP number)
- **Damage lamps distort explosion protection of the area in which it is installed!**

Opening and closing of the fluorescent light fitting:

Remove the rubber protection on the central lock switch. Turn the central axis 180° to the left (marking - OPEN) with a socket wrench. Sliders release transparent cover and the lamp opens. When closing follow the orders of operations in reverse.

When closing, pay special attention to the positioning of the seal (slot in the cover) relative to the housing.

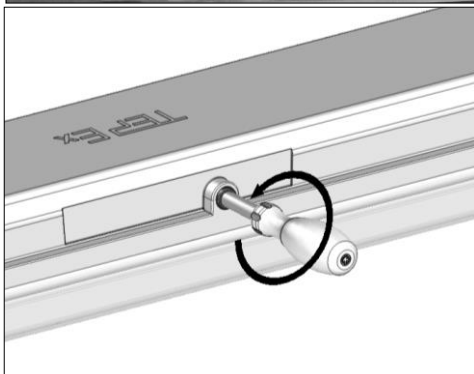

- **By turning the central lock switch, the fluorescent light fitting is in no-load state**
- **The main connections terminals: L, N**
- **In the open position, the mechanical lock prevents access to the interlocking switches**

USE MODERATE FORCE WHEN OPENING!

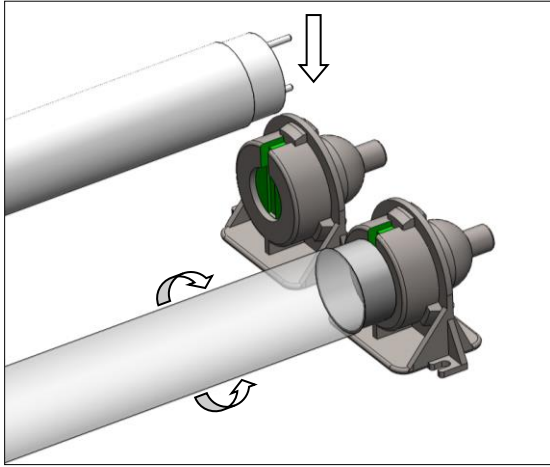
***Replacing of the fluorescent tubes ("two contacts" lamp holder G13)***

Set both ends of the fluorescent tube in the lamp holder grooves, then perform the rotation of the fluorescent tubes in the left or right side.

Internal reflector, with G13 lamp holders and T8 fluorescent tubes, is with reflector hinges and reflector lens carriers attached to the base plate at six different sites (three on each side).

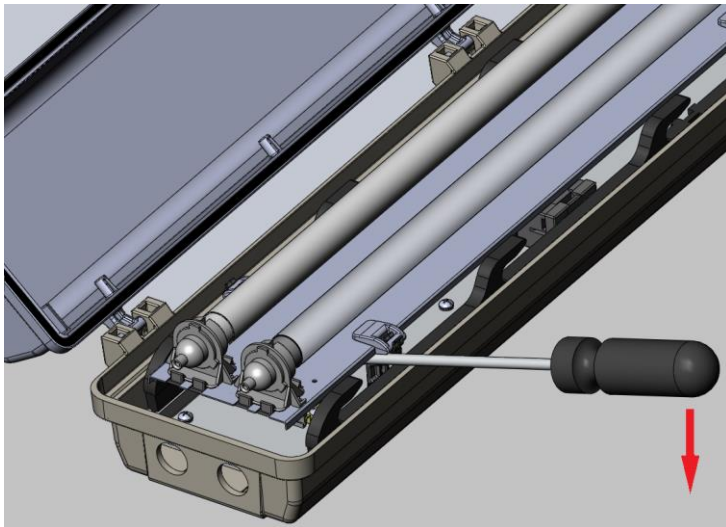
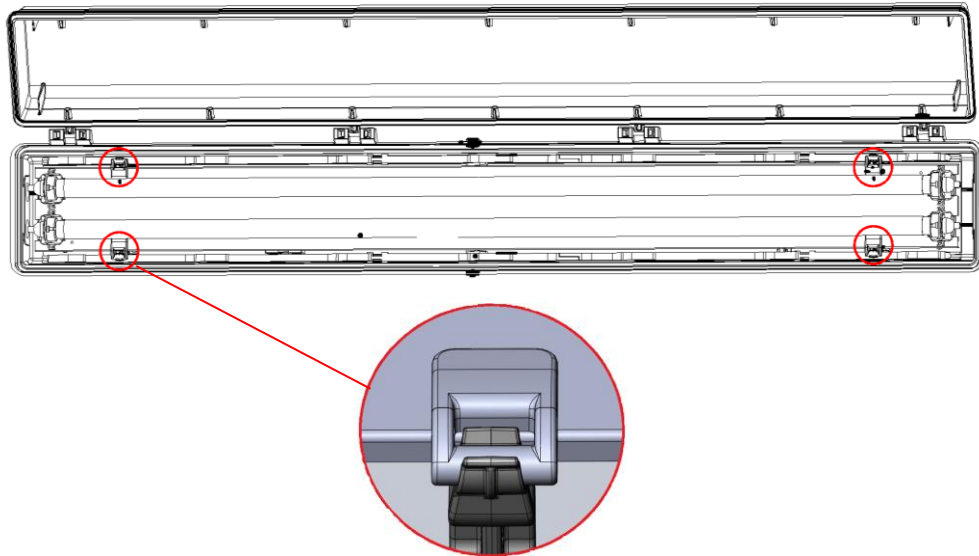

Access to terminals is done with a screwdriver in a manner that is necessary to separate the two hinge bracket of the reflector lens on the same side by applying a moderate force with a screwdriver toward the downward direction

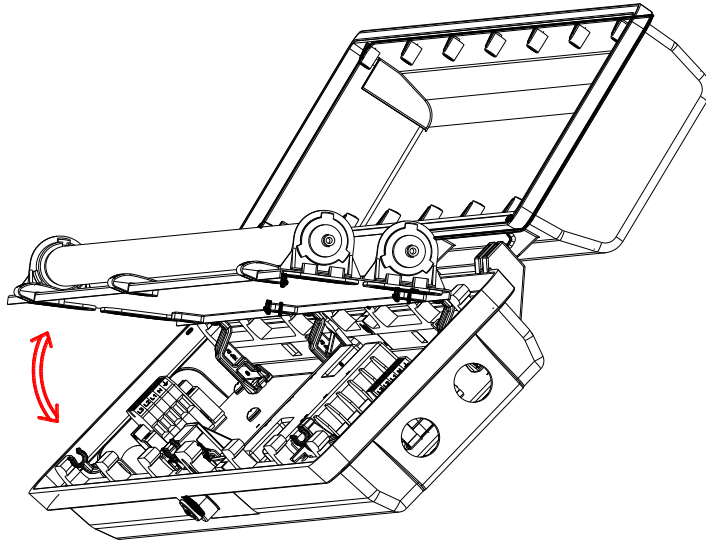

Gaining access to the terminals is achieved by rotating assembly of the reflector.

Note: it is possible to separate the three hinge reflector lends from the bracket and gain access to the other side of the terminals by rotating assembly of the reflector lends to the other side.

Closing is done in reverse order of actions by bringing hinge reflector lends back to mount of the reflector lends only by light hand pressure.

With the commissioning the control measurements of the isolation should be performed with the test voltage max. 1000 V DC and a test current 1 mA between:

- Neutral and earth conductor
- Phase and earth conductor

Testing between the phase and neutral conductor is not allowed and will get the wrong value because the electronic ballast is connected to the input circuit. For successful testing is necessary to disconnect the electronic ballast via NC switch when glass cover is opened

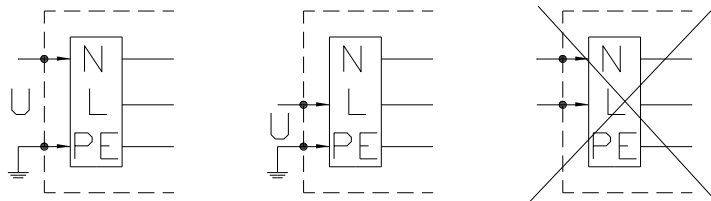

Wiring diagram PSF 236:

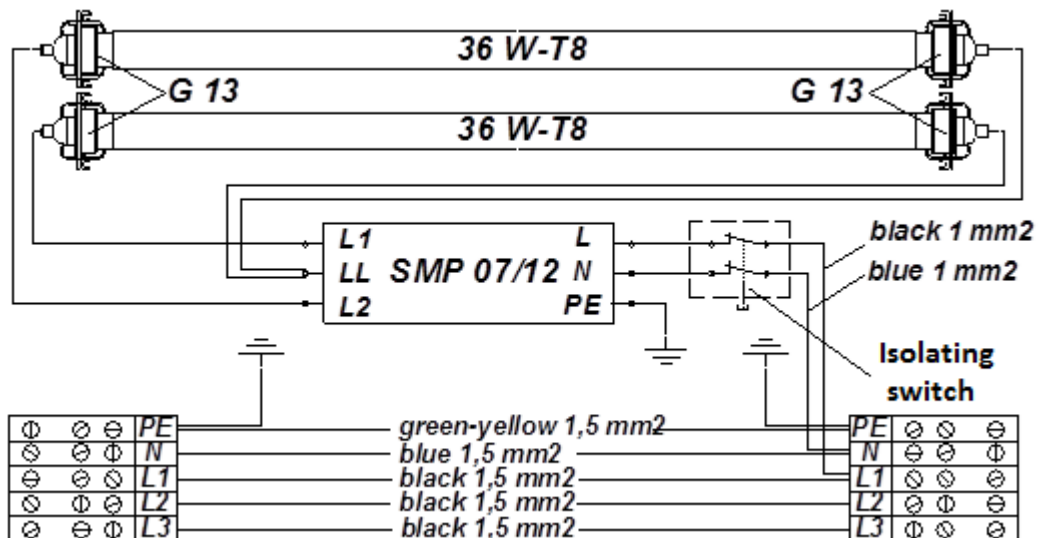

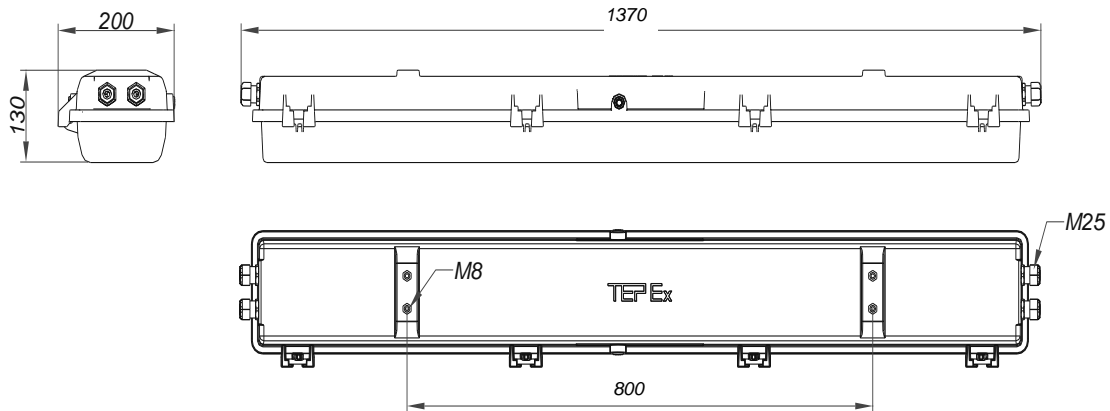
8. DIMENSION

9. SPARE PART AND ACCESSORIES

SKICA	OPIS	OZNAKA ZA NARUDŽBU	SKICA	OPIS	OZNAKA ZA NARUDŽBU
	Diffuser PSF	PSF236 20-120		Ex e cable gland SPU 25	SPU 25
	Gasket PSF	PSF236 20-130		Ex e plug M25	SPC 25
	Internal reflector with lamp holder G13 PSF	PSF236 20-140		PSF Ceiling mounting set	PSF 30-110
	El. Ballast SMP 07/12	SMP 07/12		PSF Pipe mounting set	PSF 30-120
	Terminals 5x2,5mm ²	PSF236 20-150		PSF Wall mounting set	PSF 30-130
	Socket key SW8	PSF236 20-160		Ring bolt M8	PSF 30-140
	PSF Pendant mounting set	PSF 30-150		Metal cable glands for reinforced cable M25 (cable Ø13-21mm), set	PSF 30-160

10. INSPECTION, MAINTENANCE, REPAIR AND OVERHAUL

Inspections are carried out in accordance with IEC 60079-17:2007 / C 1: 2008, general and special conditions of manufacturer and users Regulations and includes supervision of parts on which the explosion protection depends, especially:

- the housing, diffuser, cable gland, plugs and seal are without rupture and damage,
- the glands, plugs, terminals, pressure screw, intermediate gland, screw of the glass cover are fastened with nominal torque

All the repairs are performed by the manufacturer or the manufacturer's authorized personal and the original parts must be provided according to the product documentation, all in accordance with EN 60079-19:2011.

Overhaul and modifications are not allowed.

If repair or any other procedure are performed on the product by unauthorized person, all producer responsibility for the product and the warranty and the manufacturer's declaration of conformity becomes invalid.

11. RESPONSIBILITY AND AUTHORIZATION

This instruction is the basic information about the product. It is completed by the corresponding national laws and regulations.

Production, use, certification and supervision are determined at the national level:

- Regulations concerning equipment and protective systems intended for use in potentially explosive atmospheres EU directive 94/9 EC (ATEX 94)
- Regulations on minimum requirements for safety and health protection of workers and technical inspection of facilities, equipment, installations and equipment in hazardous areas EU directive 1999/92/EC (ATEX 137).

The responsible person shall ensure their implementation at the working facility

12. STORAGE AND TRANSPORT

Transportation and warehousing of the lamps is only allowed in the original packaging, as outlined in a cardboard box.

13. MANUFACTURER'S WARRANTY

The manufacturer provides a warranty on the product for a period of one year under the provisions of this user manual and the law on obligations. This statement has the force of Warranty sheet.

14. MARKING

Explosion protected fluorescent lighting fitting type PSF 236-. is marked with:

- marking label on housing of lamp with technical and certification data:

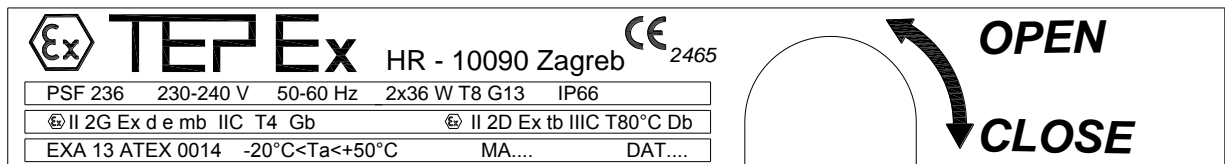

- label with technical and certification data on internal reflector inside housing:

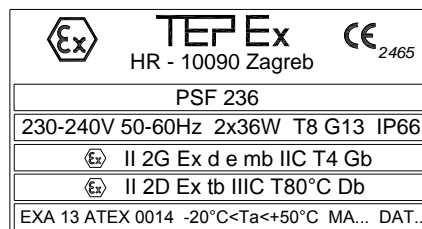

- text on diffuser (of the tool):

WARNING
POTENTIAL ELECTROSTATIC CHARGING HAZARD
CLEAN ONLY WITH A DAMP CLOTH