

INSTALLATION OPERATION AND SERVICE MANUAL

PCE – PS SERIES 4 PIPE HYDRONIC CASSETTE AIR CONDITIONERS



2007 V.1

INDEX

PCE-PS SERIES 4 PIPE HYDRONIC CASSETTES

	PAGE
A. CASSETTE MODEL ASSIGNMENTS	1
B. SPECIFICATIONS	2-8
COOLING CAPACITY TABLES	3-5
HEATING CAPACITY TABLES	6-8
C. INSTALLATION MANUAL	9
SAFETY CONSIDERATIONS	9
OPERATING LIMITS	9
BEFORE INSTALLATION	10
SELECT LOCATION	10
INSTALLATION LOCATION	11
INSTALLATION METHOD	12-16
DRAIN PIPEWORK	16
WATER CONNECTIONS	16
PIPE CONNECTION KIT (OPTION)	17
PIPE CONNECTION DIMENSIONAL DRAWING	17
EXTENDED DRAIN PAN	18
INSTALLATION PROCEDURES	18
ELECTRICAL WIRING	19
INTERCONNECTING WIRING	19
MOUNTING FRONT PANEL AND FILTER REMOVAL	20
PRELIMINARY CHECKS BEFORE START-UP	21
MAINTENANCE	21-23
FRESH AIR RENEWAL AND BRANCH DUCTING	24-25
BRANCH DUCT AND FRESH AIR DUCT INSTALLATION AND POSITIONS	25-26
BLANKING PLATES	27
D. DIMENSIONAL DRAWINGS	28-29
E. EXPLODED VIEW DRAWING	30-31
F. REMOTE CONTROL HANDSET	32
G. WIRED WALL PAD CONTROL	33
H. CONTROLS SPECIFICATION WITH MASTER-SLAVE CONTROL	34-40
I. SENSOR RESISTANCE R-T CONVERSION TABLE	41
J. CONTROL AND POWER SUPPLY WIRING DIAGRAM	42-43
K. MASTER-SLAVE CONTROL WIRING DIAGRAM	44
L. SOLENOID VALVE	45-49
M. TROUBLE SHOOTING	50-51

CASSETTE MODEL ASSIGNMENTS

P C E - 0 8 - P S

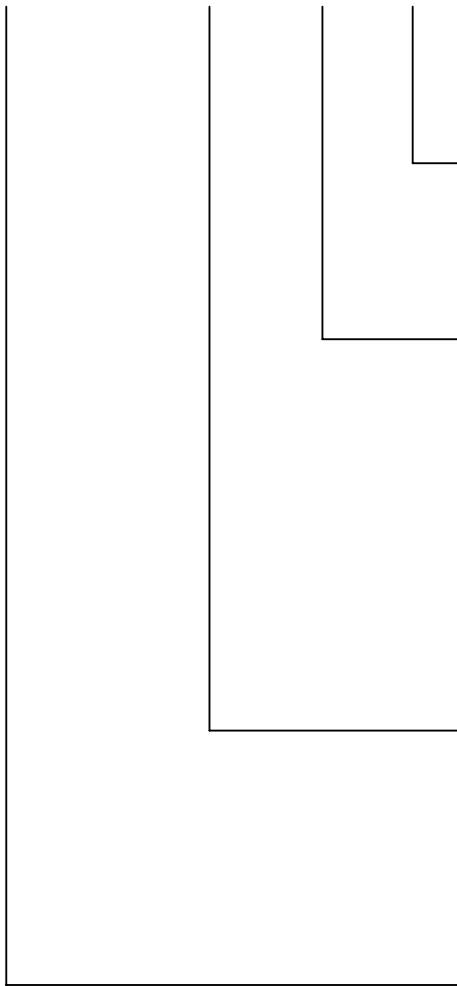

S	230V/1PH/50HZ
----------	---------------

P	CHILLED/HOT WATER, 4-PIPE
----------	---------------------------

06	NOMINAL 3 KW
08	NOMINAL 4 KW
09	NOMINAL 5.5 KW
10	NOMINAL 6.5 KW
12	NOMINAL 7.5 KW
16	NOMINAL 8.5 KW

PCE	HYDRONIC CASSETTE E SERIES
------------	----------------------------

SPECIFICATION

Model		PCE-06	PCE-08	PCE-09	PCE-10	PCE-12	PCE-16	
Nominal airflow (H / M / L)	m ³ / min	10.4 / 9.4 / 7.8	12.8 / 10.4 / 8.6	17 / 14 / 11.5	19.3 / 16 / 13	21.4 / 18.5 / 15.5	25 / 21 / 17.5	
Nominal cooling capacity (H / M / L)*	kW	3 / 2.8 / 2.4	4 / 3.2 / 2.7	5.5 / 4.8 / 4	6.5 / 5.3 / 4.5	7.5 / 5.8 / 5	8.5 / 6.5 / 5.7	
Nominal sensible cooling capacity (H / M / L)	kW	2.3 / 2 / 1.8	2.4 / 2.1 / 1.9	3.6 / 3.2 / 2.8	3.95 / 3.45 / 3.1	4.3 / 3.8 / 3.4	4.6 / 4.1 / 3.7	
Nominal heating capacity (H / M / L)**	kW	3.2 / 2.8 / 2.5	3.4 / 3 / 2.7	5.5 / 4.9 / 4.3	6 / 5.3 / 4.7	6.5 / 5.7 / 5.2	6.9 / 6.2 / 5.6	
Nominal heating capacity (H / M / L)***	kW	1.55 / 1.4 / 1.3	1.65 / 1.5 / 1.3	2.9 / 2.6 / 2.3	3.1 / 2.8 / 2.4	3.4 / 3 / 2.7	3.6 / 3.2 / 2.9	
Noise level (L / M / H) @ 1m	dB (A)	35 / 41 / 43	37 / 43 / 46	32 / 38 / 40	36 / 43 / 46	38 / 45 / 49	40 / 49 / 52	
Power supply	V / Ph / Hz	230 / 1 / 50						
No. of fan		1	1	2	2	2	2	
Fan motor power	W	54.2	70.7	33.5 x 2	54.2 x 2	60.2 x 2	70.7 x 2	
Fan motor running current	A	0.241	0.32	0.149 x 2	0.241 x 2	0.315 x 2	0.32 x 2	
Fan motor starting current	A	0.759	0.792	0.876	1.518	1.584	1.752	
Operation control		Remote Control Handset & Wired Wall Pad						
Cooling water flow rate	L / h	610	700	1,050	1,165	1,280	1,414	
Heating water flow rate	L / h	300	315	517	558	608	648	
Cooling water pressure drop	kPa	9.7	12.4	11	13.2	15.7	18.5	
Heating water pressure drop	kPa	1.1	1.2	4.75	5.45	6.4	7.1	
Cooling water content	L	0.9015	0.9015	1.5725	1.5725	1.5725	1.5725	
Heating water content	L	0.366	0.366	0.645	0.645	0.645	0.645	
Cond. drain connection I.D.	mm (in)	19.05(3/4)						
Dimensions	L	mm	570	570	1,100	1,100	1,100	1,100
	W	mm	570	570	570	570	570	570
	H	mm	290	290	290	290	290	290
Panel dimension	mm	650×650×28			690×1220×28			
Gross weight	kg	33	33	57	57	57	57	
Connection method		Socket(Threaded Female)						
Water connection	In	mm (in)	19.05(3/4)					
	Out	mm (in)	19.05(3/4)					

*Cooling: 27°C db/19.5°C wb entering air temperature, 7°C entering water and 12°C leaving water temperature with water flow rates as above.

**Heating: 20°C db entering air temperature, 70°C entering water temperature and 60°C leaving water temperature with water flow rates same as for the cooling test.

***Heating: 20°C db entering air temperature, 50°C entering water temperature and 40°C leaving water temperature with water flow rates same as for the cooling test.

COOLING CAPACITY TABLES

PCE-06				TAI DB25°C-WB17.8°C				TAI DB27°C-WB19°C				TAI DB27°C-WB19.5°C				TAI DB29°C-WB21.1°C			
Twi (°C)	Qw (l/h)	Dpw (kPa)	Qa (m³/h)	Pf (kW)	Pfs (kW)	Tad (°C)	Taw (°C)	Pf (kW)	Pfs (kW)	Tad (°C)	Taw (°C)	Pf (kW)	Pfs (kW)	Tad (°C)	Taw (°C)	Pf (kW)	Pfs (kW)	Tad (°C)	Taw (°C)
5	523	7.45	461	2.34	1.98	12.5	12.4	2.65	2.07	13.9	13.1	2.77	1.98	14.4	13.4	3.34	2.07	15.8	14.1
	617	10.1	561	2.7	2.19	13.6	12.7	3.12	2.34	14.8	13.3	3.27	2.25	15.2	13.6	3.95	2.36	16.6	14.3
	725	13.4	681	3.15	2.47	14.4	12.9	3.66	2.65	15.6	13.5	2.84	2.54	16.0	13.8	4.64	2.66	17.4	14.5
7	444	5.7	462	1.93	1.67	14.4	13.4	2.22	1.83	15.3	14.1	2.35	1.77	15.7	14.4	2.85	1.84	17.2	15.2
	520	7.6	560	2.2	1.92	15	13.7	2.6	2.08	16.1	14.3	2.75	1.99	16.5	14.6	3.35	2.08	18	15.4
	606	9.7	682	2.54	2.2	15.5	13.9	3.02	2.35	16.8	14.5	3.21	2.26	17.2	14.8	3.93	2.33	18.8	15.6
9	312	2.93	463	1.25	1.22	17.2	15	1.57	1.53	17.2	15.6	1.65	1.55	17.1	16	2.03	1.65	18.4	17
	357	3.74	562	1.36	1.32	18	15.3	1.8	1.76	17.7	15.8	1.89	1.76	17.7	16.2	2.35	1.84	19.2	17.2
	408	4.76	682	1.52	1.49	18.5	15.5	2.05	1.99	18.3	16	2.16	1.99	18.3	16.4	2.71	2.07	19.9	17.4
11	259	2.1	462	1.16	1.14	17.7	15.2	1.34	1.31	18.5	16.1	1.37	1.30	18.6	16.6	1.75	1.36	20.2	17.6
	295	2.65	563	1.2	1.17	18.8	15.6	1.52	1.48	19.1	16.3	1.56	1.47	19.2	16.8	2.0	1.53	20.8	17.8
	330	3.26	682	1.26	1.23	19.6	15.9	1.72	1.67	19.7	16.5	1.75	1.66	19.7	17	2.28	1.72	21.4	18
13	206	1.39	461	0.81	0.79	19.9	16	1.07	1.05	20.2	16.7	1.09	1.05	20.2	17.2	1.3	1.19	21.2	18.5
	230	1.7	563	0.82	0.80	20.7	16.3	1.19	1.16	20.8	16.9	1.22	1.18 ₃	20.7	17.4	1.48	1.35	21.8	18.7
	253	2.02	683	0.87	0.84	21.3	16.5	1.31	1.27	21.4	17.1	1.34	1.29	21.3	17.6	1.64	1.52	22.3	18.9

TAI: Air in temperature
 Twi: Fluid in temperature
 Qw: Fluid flow rate in heat exchanger
 Dpw: Pressure drop standard coil
 Qa: Air flow
 Pf: Total cooling capacity
 Pfs: Sensible cooling capacity
 Tad: Discharge air dry bulb temperature
 Taw: Discharge air wet bulb temperature

Note: Design and specification are subject to change without prior notice for product improvement.

PCE-08				TAI DB25°C-WB17.8°C				TAI DB27°C-WB19°C				TAI DB27°C-WB19.5°C				TAI DB29°C-WB21.1°C			
Twi (°C)	Qw (l/h)	Dpw (kPa)	Qa (m³/h)	Pf (kW)	Pfs (kW)	Tad (°C)	Taw (°C)	Pf (kW)	Pfs (kW)	Tad (°C)	Taw (°C)	Pf (kW)	Pfs (kW)	Tad (°C)	Taw (°C)	Pf (kW)	Pfs (kW)	Tad (°C)	Taw (°C)
5	612	9.88	516	2.7	2.05	13.4	12.2	3.17	2.19	14.5	12.6	3.24	2.13	14.9	13.1	3.81	2.26	16.1	13.9
	718	13.2	624	3.16	2.33	14.1	12.4	3.68	2.49	15.3	12.9	3.8	2.4	15.7	13.3	4.49	2.53	17	14.1
	840	17.5	751	3.66	2.61	14.8	12.6	4.28	2.78	16.1	13.1	4.43	2.67	16.5	13.5	5.25	2.83	17.8	14.3
7	514	7.21	516	2.2	1.81	14.7	13.3	2.63	1.95	15.9	13.8	2.72	1.87	16.3	14.2	3.28	1.98	17.6	15
	599	9.5	624	2.52	2.06	15.2	13.5	3.06	2.2	16.6	14	3.17	2.11	17	14.4	3.84	2.23	18.4	15.2
	693	12.4	750	2.93	2.32	15.9	13.7	3.53	2.46	17.3	14.2	3.67	2.35	17.7	14.6	4.47	2.47	19.2	15.4
9	366	3.92	517	1.44	1.41	16.9	14.9	1.85	1.72	17.1	15.4	1.94	1.64	17.6	15.8	2.46	1.72	19.2	16.7
	421	5.04	626	1.63	1.58	17.5	15.1	2.12	1.96	17.7	15.6	2.23	1.85	18.2	16	2.8	1.94	19.7	16.9
	478	6.33	752	1.82	1.77	18	15.3	2.4	2.19	18.3	15.8	2.53	2.1	18.7	16.2	3.21	2.15	20.4	17.1
11	270	2.27	517	1.05	1.02	19.1	15.7	1.4	1.37	19.1	16.3	1.43	1.38	19	16.8	1.73	1.53	20.1	18
	302	2.77	624	1.16	1.13	19.6	15.9	1.57	1.52	19.7	16.5	1.6	1.56	19.5	17	1.96	1.72	20.7	18.2
	350	3.6	750	1.245	1.2	20.2	16.1	1.74	1.7	20.2	16.7	1.85	1.80	19.8	17.1	2.28	1.92	21.3	18.3
13	212	1.46	518	0.605	0.582	21.6	16.6	1.1	1.07	20.8	16.9	1.12	1.09	20.7	17.4	1.35	1.31	21.4	18.7
	233	1.73	626	0.675	0.644	21.9	16.7	1.2	1.16	21.4	17.1	1.23	1.19	21.3	17.6	1.5	1.45	22	18.9
	250	1.96	751	0.74	0.7	22.2	16.8	1.29	1.25	22	17.3	1.32	1.27	21.9	17.8	1.64	1.59	22.6	19.1

TAI: Air in temperature
 Twi: Fluid in temperature
 Qw: Fluid flow rate in heat exchanger
 Dpw: Pressure drop standard coil
 Qa: Air flow
 Pf: Total cooling capacity
 Pfs: Sensible cooling capacity
 Tad: Discharge air dry bulb temperature
 Taw: Discharge air wet bulb temperature

Note: Design and specification are subject to change without prior notice for product improvement.

PCE-PS SERIES: 4-PIPE HYDRONIC CASSETTE UNIT

PCE-09				TAI DB25°C-WB17.8°C				TAI DB27°C-WB19°C				TAI DB27°C-WB19.5°C				TAI DB29°C-WB21.1°C			
Twi (°C)	Qw (1/h)	Dpw (kPa)	Qa (m ³ /h)	Pf (kW)	Pfs (kW)	Tad (°C)	Taw (°C)	Pf (kW)	Pfs (kW)	Tad (°C)	Taw (°C)	Pf (kW)	Pfs (kW)	Tad (°C)	Taw (°C)	Pf (kW)	Pfs (kW)	Tad (°C)	Taw (°C)
5	878	7.96	691	3.98	3.02	12.3	11.6	4.5	3.26	13.2	12.2	4.65	3.17	13.6	12.6	5.55	3.34	14.8	13.2
	1038	10.77	841	4.69	3.43	13.1	11.8	5.33	3.71	14.1	12.4	5.5	3.61	14.4	12.8	6.59	3.79	15.7	13.4
	1227	14.55	1023	5.51	3.91	13.8	12	6.28	4.21	14.9	12.6	6.5	4.07	15.3	13	7.8	4.28	16.6	13.6
7	759	6.13	690	3.38	2.62	13.9	12.6	3.89	2.87	14.8	13.2	4.02	2.77	15.2	13.6	4.78	2.99	16.2	14.4
	897	8.27	843	3.96	3.01	14.5	12.8	4.58	3.29	15.5	13.4	4.75	3.17	15.9	13.8	5.66	3.38	17.1	14.6
	1050	11	1021	4.63	3.41	15.2	13	5.37	3.7	16.3	13.6	5.56	3.55	16.7	14	6.67	3.78	18	14.8
9	616	4.2	692	2.54	2.32	15	13.9	3.13	2.5	16.3	14.4	3.26	2.41	16.7	14.8	3.86	2.63	17.7	15.8
	717	5.54	841	2.98	2.66	15.7	14.1	3.65	2.87	16.9	14.6	3.8	2.75	17.3	15	4.53	2.97	18.5	16
	834	7.27	1021	3.42	3.04	16.2	14.3	4.24	3.23	17.6	14.8	4.42	3.09	18	15.2	5.29	3.35	19.2	16.2
11	464	2.53	691	1.8	1.75	17.5	15.1	2.28	2.19	17.6	15.7	2.46	2.04	18.2	16	2.9	2.3	19.1	17.2
	534	3.26	842	2.04	1.99	18	15.3	2.61	2.52	18.1	15.9	2.83	2.34	18.7	16.2	3.34	2.61	19.7	17.4
	610	4.13	1020	2.28	2.23	18.5	15.5	2.97	2.84	18.7	16.1	3.23	2.67	19.2	16.4	3.85	2.93	20.4	17.6
13	334	1.4	690	1.28	1.25	19.6	15.9	1.74	1.69	19.7	16.5	1.77	1.71	19.6	17	2.03	1.99	20.4	18.4
	376	1.73	841	1.4	1.35	20.2	16.1	1.95	1.91	20.2	16.7	1.99	1.94	20.1	17.2	2.29	2.24	21	18.6
	418	2.1	1021	1.5	1.47	20.7	16.3	2.17	2.11	20.8	16.9	2.21	2.14	20.7	17.4	2.67	2.48	21.7	18.7

TAI: Air in temperature
 Twi: Fluid in temperature
 Qw: Fluid flow rate in heat exchanger
 Dpw: Pressure drop standard coil
 Qa: Air flow
 Pf: Total cooling capacity
 Pfs: Sensible cooling capacity
 Tad: Discharge air dry bulb temperature
 Taw: Discharge air wet bulb temperature

Note: Design and specification are subject to change without prior notice for product improvement.

PCE-10				TAI DB25°C-WB17.8°C				TAI DB27°C-WB19°C				TAI DB27°C-WB19.5°C				TAI DB29°C-WB21.1°C			
Twi (°C)	Qw (1/h)	DPw (kPa)	Qa (m ³ /h)	Pf (kW)	Pfs (kW)	Tad (°C)	Taw (°C)	Pf (kW)	Pfs (kW)	Tad (°C)	Taw (°C)	Pf (kW)	Pfs (kW)	Tad (°C)	Taw (°C)	Pf (kW)	Pfs (kW)	Tad (°C)	Taw (°C)
5	965	9.44	780	4.49	3.24	12.9	11.6	4.95	3.58	13.6	12.4	5.11	3.46	14	12.8	5.92	3.72	15	13.7
	1154	13.02	960	5.35	3.71	13.7	11.8	5.91	4.09	14.5	12.6	6.11	3.96	14.9	13	7.1	4.24	16	13.9
	1365	17.62	1171	6.22	4.24	14.4	12.1	7.0	4.62	15.4	12.8	7.23	4.45	15.8	13.2	8.42	4.79	16.9	14.1
7	833	7.24	782	3.74	2.88	14.2	12.7	4.25	3.16	15.1	13.4	4.41	3.03	15.6	13.8	5.11	3.3	16.5	14.8
	989	9.87	961	4.43	3.3	14.9	12.9	5.05	3.58	16	13.6	5.24	3.45	16.4	14.0	6.1	3.76	17.4	15
	1163	13.21	1170	5.19	3.74	15.6	13.1	5.94	4.08	16.7	13.8	6.16	3.91	17.1	14.2	7.21	4.22	18.3	15.2
9	680	5.02	780	2.84	2.55	15.4	14	3.45	2.71	16.5	14.4	3.6	2.63	17	14.9	4.21	2.89	18	16
	802	6.77	961	3.31	2.93	16	14.2	4.17	3.08	17.5	14.6	4.25	3.01	17.7	15.1	4.98	3.29	18.8	16.2
	936	8.94	1172	3.82	3.33	16.6	14.4	4.86	3.51	18.1	14.8	4.96	3.39	18.4	15.3	5.83	3.72	19.5	16.4
11	423	2.14	781	1.89	1.84	18	15.3	2.2	2.15	18.8	16.2	2.24	2.17	18.7	16.7	2.78	2.49	19.5	17.8
	502	2.95	961	2.15	2.11	18.5	15.5	2.61	2.55	19.1	16.3	2.66	2.58	19	16.8	3.22	2.85	20.1	18
	568	3.64	1172	2.39	2.32	19.1	15.7	2.95	2.86	19.7	16.5	3.01	2.94	19.5	17	3.68	3.24	20.7	18.2
13	334	1.4	781	1.3	1.26	20.2	16.1	1.74	1.7	20.5	16.8	1.77	1.72	20.4	17.3	2.13	2.08	21	18.6
	374	1.71	960	1.41	1.38	20.7	16.3	1.95	1.89	21.1	17	1.98	1.92	21	17.5	2.41	2.33	21.7	18.8
	412	2.04	1172	1.49	1.44	21.3	16.5	2.14	2.11	21.6	17.2	2.18	2.1	21.6	17.7	2.69	2.6	22.3	19

TAI: Air in temperature
 Twi: Fluid in temperature
 Qw: Fluid flow rate in heat exchanger
 Dpw: Pressure drop standard coil
 Qa: Air flow
 Pf: Total cooling capacity
 Pfs: Sensible cooling capacity
 Tad: Discharge air dry bulb temperature
 Taw: Discharge air wet bulb temperature

Note: Design and specification are subject to change without prior notice for product improvement.

PCE-PS SERIES: 4-PIPE HYDRONIC CASSETTE UNIT

PCE-12				TAI DB25°C-WB17.8°C				TAI DB27°C-WB19°C				TAI DB27°C-WB19.5°C				TAI DB29°C-WB21.1°C			
Twi (°C)	Qw (1/h)	DPw (kPa)	Qa (m ³ /h)	Pf (kW)	Pfs (kW)	Tad (°C)	Taw (°C)	Pf (kW)	Pfs (kW)	Tad (°C)	Taw (°C)	Pf (kW)	Pfs (kW)	Tad (°C)	Taw (°C)	Pf (kW)	Pfs (kW)	Tad (°C)	Taw (°C)
5	1023	10.5	930	4.55	3.73	13.3	12.6	5.24	4.03	14.3	13.2	5.42	3.89	14.7	13.6	6.36	4.13	15.9	14.5
	1182	13.6	1109	5.23	4.17	14	12.8	6.05	4.5	15.1	13.4	6.26	4.37	15.4	13.8	7.38	4.62	16.7	14.7
	1399	18.42	1360	6.16	4.77	14.7	13	7.16	5.08	16	13.6	7.41	4.92	16.3	14	8.76	5.18	17.7	14.9
7	942	9.04	931	4.13	3.23	14.8	13.1	4.81	3.5	15.9	13.7	4.99	3.37	16.3	14.1	5.82	3.67	17.3	15.1
	1084	11.63	1110	4.73	3.62	15.4	13.3	5.54	3.95	16.5	13.9	5.74	3.79	16.9	14.3	6.73	4.07	18.1	15.3
	1280	15.7	1360	5.55	4.11	16.1	13.5	6.53	4.46	17.3	14.1	6.78	4.31	17.6	14.5	7.98	4.57	19	15.5
9	795	6.66	932	3.37	2.8	16.1	14	4.04	3.05	17.3	14.6	4.21	2.92	17.7	15	5.0	3.18	18.8	16
	908	8.46	1112	3.82	3.15	16.6	14.2	4.61	3.4	17.9	14.8	4.81	3.25	18.3	15.2	5.75	3.53	19.5	16.2
	1063	11.3	1362	4.44	3.59	17.2	14.4	5.39	3.89	18.5	15	5.63	3.7	18.9	15.4	6.78	3.96	20.3	16.4
11	504	2.93	931	2.08	2.0	18.6	15.5	2.62	2.56	18.8	16.2	2.67	2.53	18.9	16.7	3.32	2.74	20.2	17.8
	559	3.53	1110	2.27	2.2	19.1	15.7	2.91	2.83	19.4	16.4	2.96	2.86	19.3	16.9	3.73	3.04	20.8	18
	634	4.44	1362	2.52	2.46	19.6	15.9	3.29	3.23	19.9	16.6	3.36	3.23	19.9	17.1	4.28	3.39	21.5	18.2
13	362	1.62	930	1.54	1.49	20.2	16.1	1.88	1.83	21.1	17	1.92	1.86	21	17.5	2.63	2.1	22.2	18.5
	412	2.04	1111	1.74	1.67	20.5	16.2	2.14	2.07	21.4	17.1	2.18	2.11	21.3	17.6	2.91	2.43	22.4	18.7
	451	2.4	1360	1.86	1.81	21	16.4	2.35	2.26	22	17.3	2.39	2.3	21.9	17.8	3.27	2.7	23	18.9

TAI: Air in temperature
 Twi: Fluid in temperature
 Qw: Fluid flow rate in heat exchanger
 Dpw: Pressure drop standard coil
 Qa: Air flow
 Pf: Total cooling capacity
 Pfs: Sensible cooling capacity
 Tad: Discharge air dry bulb temperature
 Taw: Discharge air wet bulb temperature

Note: Design and specification are subject to change without prior notice for product improvement.

PCE-16				TAI DB25°C-WB17.8°C				TAI DB27°C-WB19°C				TAI DB27°C-WB19.5°C				TAI DB29°C-WB21.1°C			
Twi (°C)	Qw (1/h)	DPw (kPa)	Qa (m ³ /h)	Pf (kW)	Pfs (kW)	Tad (°C)	Taw (°C)	Pf (kW)	Pfs (kW)	Tad (°C)	Taw (°C)	Pf (kW)	Pfs (kW)	Tad (°C)	Taw (°C)	Pf (kW)	Pfs (kW)	Tad (°C)	Taw (°C)
5	1173	13.4	1050	5.4	3.95	14	12.3	6.0	4.32	14.9	13.1	6.21	4.18	15.3	13.5	7.36	4.44	16.5	14.3
	1361	17.6	1259	6.25	4.42	14.7	12.5	6.97	4.84	15.7	13.3	7.21	4.7	16	13.7	8.59	4.93	17.4	14.5
	1570	22.6	1500	7.18	4.95	15.3	12.7	8.03	5.4	16.4	13.5	8.31	5.23	16.7	13.9	9.94	5.46	18.2	14.7
7	1063	11.4	1050	4.84	3.43	15.4	12.9	5.43	3.77	16.4	13.7	5.63	3.66	16.7	14.1	6.74	3.9	18.1	15
	1230	14.6	1260	5.59	3.85	16	13.1	6.28	4.22	17.1	13.9	6.51	4.08	17.4	14.3	7.75	4.32	18.8	15.2
	1413	18.8	1501	6.38	4.27	16.6	13.3	7.2	4.71	17.7	14.1	7.48	4.55	18	14.5	8.94	4.78	19.5	15.4
9	860	7.6	1051	3.9	2.95	16.7	13.9	4.46	3.26	17.8	14.7	4.55	3.15	18.1	15.2	5.34	3.45	19.2	16.3
	984	9.77	1260	4.45	3.27	17.3	14.1	5.11	3.64	18.4	14.9	5.21	3.51	18.7	15.4	6.15	3.83	19.9	16.5
	1118	12.3	1502	5.02	3.69	17.7	14.3	5.8	4.08	18.9	15.1	5.92	3.93	19.2	15.6	7.03	4.26	20.5	16.7
11	570	3.64	1050	2.45	2.38	18.3	15.4	2.95	2.85	18.9	16.2	3.01	2.74	19.2	16.7	3.53	3.05	20.3	18.0
	635	4.44	1260	2.69	2.63	18.8	15.6	3.3	3.21	19.4	16.4	3.36	3.07	19.7	16.9	3.96	3.44	20.8	18.2
	700	5.3	1500	2.92	2.87	19.3	15.8	3.63	3.56	19.9	16.6	3.7	3.46	20.1	17.1	4.41	3.8	21.4	18.4
13	431	2.21	1053	1.85	1.8	19.9	16.0	2.23	2.17	20.8	16.9	2.28	2.21	20.7	17.4	2.75	2.51	21.8	18.7
	467	2.55	1260	1.97	1.94	20.4	16.2	2.43	2.35	21.4	17.1	2.47	2.39	21.3	17.6	3.03	2.85	22.2	18.9
	500	2.87	1501	2.06	2.0	21	16.4	2.59	2.5	22	17.3	2.64	2.54	21.9	17.8	3.28	3.18	22.6	19.1

TAI: Air in temperature
 Twi: Fluid in temperature
 Qw: Fluid flow rate in heat exchanger
 Dpw: Pressure drop standard coil
 Qa: Air flow
 Pf: Total cooling capacity
 Pfs: Sensible cooling capacity
 Tad: Discharge air dry bulb temperature
 Taw: Discharge air wet bulb temperature

Note: Design and specification are subject to change without prior notice for product improvement.

PCE-PS SERIES: 4-PIPE HYDRONIC CASSETTE UNIT

HEATING CAPACITY TABLES

PCE-06				TAI 18°C		TAI 20°C		TAI 22°C		TAI 24°C	
Twi (°C)	Qw (1/h)	Dpw (kPa)	Qa (m ³ /h)	Pf (kW)	Tad (°C)	Pf (kW)	Tad (°C)	Pf (kW)	Tad (°C)	Pf (kW)	Tad (°C)
40	58	0.06	460	0.70	22.7	0.61	24.1	0.58	25.9	0.51	27.4
	64	0.07	563	0.78	22.3	0.68	23.7	0.64	25.5	0.57	27.1
	71	0.08	686	0.87	21.9	0.755	23.4	0.71	25.2	0.63	26.9
50	116	0.2	466	1.35	27.0	1.23	28.2	1.18	29.8	1.1	31.3
	129	0.24	564	1.51	26.3	1.37	27.5	1.32	29.2	1.22	30.7
	144	0.3	685	1.68	25.6	1.53	26.9	1.47	28.6	1.36	30.2
60	176	0.42	464	2.17	29.9	1.86	32.3	1.96	32.8	1.71	35.4
	196	0.51	564	2.23	30.3	2.08	31.4	2.02	33.1	1.92	34.5
	220	0.63	684	2.50	29.3	2.33	30.5	2.26	32.2	2.14	33.7
70	237	0.72	467	2.66	35.6	2.51	36.6	2.45	38.3	2.35	39.5
	265	0.88	563	2.97	34.3	2.81	35.4	2.74	37	2.63	38.4
	296	1.08	688	3.33	33.0	3.14	34.1	3.07	35.8	2.95	37.2

TAI: Air in temperature
 Twi: Fluid in temperature
 Pf: Total heating capacity
 Qw: Fluid flow rate in heat exchanger
 Tad: Discharge air temperature
 Dpw: Pressure drop standard coil
 Qa: Air flow

Note: Design and specification are subject to change without prior notice for product improvement.

PCE-08				TAI 18°C		TAI 20°C		TAI 22°C		TAI 24°C	
Twi (°C)	Qw (1/h)	Dpw (kPa)	Qa (m ³ /h)	Pf (kW)	Tad (°C)	Pf (kW)	Tad (°C)	Pf (kW)	Tad (°C)	Pf (kW)	Tad (°C)
40	61	0.06	512	0.744	22.5	0.65	23.9	0.609	25.7	0.541	27.3
	68	0.08	623	0.828	22.1	0.72	23.6	0.677	25.4	0.602	27.0
	75	0.09	755	0.915	21.7	0.79	23.3	0.749	25.1	0.666	26.7
50	122	0.22	512	1.425	26.6	1.30	27.8	1.247	29.5	1.157	31.0
	137	0.27	624	1.596	25.9	1.45	27.2	1.396	28.9	1.298	30.4
	152	0.32	754	1.773	25.8	1.61	26.6	1.55	28.4	1.44	29.9
60	186	0.47	516	2.306	29.4	1.97	31.8	2.09	32.3	1.98	33.7
	209	0.57	627	2.38	29.7	2.211	30.93	2.153	32.6	2.04	34.1
	232	0.69	753	2.642	28.8	2.46	30.1	2.39	31.8	2.264	33.3
70	250	0.79	512	2.81	34.9	2.65	36.0	2.59	37.7	2.484	39.0
	281	0.98	626	3.16	33.6	2.98	34.7	2.92	36.4	2.79	37.8
	313	1.19	754	3.52	32.4	3.32	33.6	3.24	35.3	3.11	36.8

TAI: Air in temperature
 Twi: Fluid in temperature
 Pf: Total heating capacity
 Qw: Fluid flow rate in heat exchanger
 Tad: Discharge air temperature
 Dpw: Pressure drop standard coil
 Qa: Air flow

Note: Design and specification are subject to change without prior notice for product improvement.

PCE-PS SERIES: 4-PIPE HYDRONIC CASSETTE UNIT

PCE-09				TAI 18°C		TAI 20°C		TAI 22°C		TAI 24°C	
Twi (°C)	Qw (l/h)	Dpw (kPa)	Qa (m³/h)	Pf (kW)	Tad (°C)	Pf (kW)	Tad (°C)	Pf (kW)	Tad (°C)	Pf (kW)	Tad (°C)
40	114	0.31	692	1.39	24.2	1.21	25.4	1.14	27.1	1.01	28.5
	127	0.39	841	1.56	23.7	1.36	25	1.27	26.7	1.13	28.1
	143	0.47	1019	1.74	23.3	1.52	24.6	1.42	26.3	1.267	27.85
50	211	0.94	689	2.45	29	2.23	30	2.14	31.6	1.99	32.8
	237	1.16	843	2.76	28.1	2.51	29.2	2.41	30.9	2.24	32.2
	265	1.42	1022	3.09	27.3	2.81	28.5	2.71	30.2	2.51	31.6
60	309	1.87	692	3.51	33.7	3.27	34.6	3.17	36.2	3.01	37.4
	348	2.33	845	3.96	32.5	3.69	33.5	3.58	35.7	3.39	36.4
	389	2.84	1019	4.43	31.4	4.12	32.5	4.01	34.2	3.79	35.5
70	407	3.08	694	4.57	38.4	4.31	39.2	4.23	40.8	4.05	42
	460	3.83	845	5.16	36.8	4.87	37.8	4.76	39.4	4.57	40.7
	517	4.73	1020	5.7	35.2	5.48	36.6	5.26	37.9	5.05	39.3

TAI: Air in temperature
 Twi: Fluid in temperature
 Pf: Total heating capacity
 Qw: Fluid flow rate in heat exchanger
 Tad: Discharge air temperature
 Dpw: Pressure drop standard coil
 Qa: Air flow

Note: Design and specification are subject to change without prior notice for product improvement.

PCE-10				TAI 18°C		TAI 20°C		TAI 22°C		TAI 24°C	
Twi (°C)	Qw (l/h)	Dpw (kPa)	Qa (m³/h)	Pf (kW)	Tad (°C)	Pf (kW)	Tad (°C)	Pf (kW)	Tad (°C)	Pf (kW)	Tad (°C)
40	123	0.36	788	1.50	23.9	1.3	25.1	1.23	26.8	1.09	28.32
	138	0.44	960	1.68	23.4	1.46	24.7	1.377	26.43	1.224	27.94
	154	0.53	1171	1.882	22.96	1.63	24.3	1.54	26	1.37	27.6
50	226	1.06	777	2.63	28.45	2.39	29.5	2.3	31.15	2.13	32.5
	256	1.33	963	2.98	27.6	2.71	28.7	2.61	30.4	2.426	31.76
	288	1.65	1178	3.36	26.8	3.05	28	2.94	29.7	2.73	31.15
60	331	2.13	780	3.78	32.9	3.51	33.9	3.41	35.5	3.24	36.8
	377	2.68	963	4.29	31.75	3.99	32.8	3.87	34.4	3.67	35.8
	423	3.30	1173	4.81	30.7	4.48	31.8	4.36	33.5	4.13	34.9
70	438	3.51	779	4.71	38.2	4.64	38.4	4.35	40.7	4.17	41.9
	497	4.40	962	5.58	35.9	5.26	36.9	5.15	38.6	4.94	39.9
	558	5.43	1171	6.27	34.6	5.91	35.6	5.79	37.3	5.55	38.6

TAI: Air in temperature
 Twi: Fluid in temperature
 Pf: Total heating capacity
 Qw: Fluid flow rate in heat exchanger
 Tad: Discharge air temperature
 Dpw: Pressure drop standard coil
 Qa: Air flow

Note: Design and specification are subject to change without prior notice for product improvement.

PCE-PS SERIES: 4-PIPE HYDRONIC CASSETTE UNIT

PCE-12				TAI 18°C		TAI 20°C		TAI 22°C		TAI 24°C	
Twi (°C)	Qw (1/h)	Dpw (kPa)	Qa (m³/hj)	Pf (kW)	Tad (°C)	Pf (kW)	Tad (°C)	Pf (kW)	Tad (°C)	Pf (kW)	Tad (°C)
40	136	0.43	927	1.653	23.51	1.44	24.8	1.35	26.5	1.2	28
	149	0.51	1110	1.82	23.1	1.58	24.4	1.492	26.15	1.33	27.7
	165	0.61	1352	2.03	22.63	1.75	24	1.66	25.8	1.47	27.38
50	251	1.29	934	2.93	27.7	2.66	28.8	2.56	30.5	2.38	31.9
	278	1.54	1108	3.24	27.05	2.94	28.2	2.83	29.9	2.635	31.35
	312	1.91	1357	3.64	26.3	3.31	27.5	3.188	29.26	2.96	30.74
60	369	2.58	937	4.21	31.9	3.91	32.9	3.81	34.6	3.61	35.9
	409	3.10	1106	4.65	31	4.33	32.1	4.21	33.8	3.99	35.1
	459	3.82	1353	5.23	29.9	4.86	31.1	4.73	32.8	4.48	34.3
70	489	4.28	936	5.49	36.1	5.18	37.1	5.07	38.7	4.85	40
	539	5.10	1103	6.06	35	5.71	36	5.58	37.6	5.36	39
	608	6.34	1354	6.83	33.6	6.44	34.7	6.31	36.4	6.04	37.8

TAI: Air in temperature
 Twi: Fluid in temperature
 Pf: Total heating capacity
 Qw: Fluid flow rate in heat exchanger
 Tad: Discharge air temperature
 Dpw: Pressure drop standard coil
 Qa: Air flow

Note: Design and specification are subject to change without prior notice for product improvement.

PCE-16				TAI 18°C		TAI 20°C		TAI 22°C		TAI 24°C	
Twi (°C)	Qw (1/h)	Dpw (kPa)	Qa (m³/hj)	Pf (kW)	Tad (°C)	Pf (kW)	Tad (°C)	Pf (kW)	Tad (°C)	Pf (kW)	Tad (°C)
40	144	0.48	1051	1.76	23.2	1.53	24.5	1.444	26.24	1.284	27.77
	161	0.58	1258	1.963	22.83	1.71	24.2	1.6	25.94	1.425	27.5
	178	0.70	1498	2.158	22.45	1.89	23.9	1.77	25.65	1.574	27.25
50	270	1.47	1052	3.146	27.24	2.86	28.4	2.75	30.1	2.55	31.5
	300	1.78	1260	3.52	26.0	3.18	27.8	3.06	29.5	2.98	30.7
	331	2.13	1507	3.86	25.92	3.51	27.2	3.37	28.9	3.14	30.42
60	397	2.95	1049	4.51	31.3	4.21	32.4	4.08	34.0	3.87	35.4
	440	3.54	1263	5.02	30.3	4.66	31.4	4.54	33.1	4.30	34.5
	487	4.25	1504	5.55	29.4	5.16	30.6	5.01	32.3	4.76	33.8
70	525	4.86	1054	5.89	35.3	5.56	36.3	5.45	37.9	5.22	39.3
	583	5.88	1265	6.56	34.05	6.18	25.1	6.06	36.8	5.81	38.2
	648	7.10	1503	7.24	32.9	6.84	34.1	6.7	35.8	6.42	37.2

TAI: Air in temperature
 Twi: Fluid in temperature
 Pf: Total heating capacity
 Qw: Fluid flow rate in heat exchanger
 Tad: Discharge air temperature
 Dpw: Pressure drop standard coil
 Qa: Air flow

Note: Design and specification are subject to change without prior notice for product improvement.

THE INSTALLATION MANUAL

HOT & CHILLED WATER SYSTEM AIR CONDITIONERS

First check the contents of the package.

FACTORY SUPPLIED ACCESSORIES

Check to ensure all factory supplied accessories are supplied with the unit.

FACTORY SUPPLIED ACCESSORIES	AMOUNT
LCD Remote control	1
Mounting Bracket (Already on the unit)	1
Installation manual	1
Batteries	2
External drain pan	1

The appliance should be installed in accordance with national wiring regulation.

SAFETY CONSIDERATIONS

1. When working on air conditioning equipment, observe precautions in this manual, and on plates and tables attached to the unit. Follow all safety codes and other safety precautions that may apply.
2. Installing and servicing air conditioning equipment should be done by trained and qualified service personnel only. Untrained personnel can perform only basic maintenance functions such as cleaning coils, filters and replacing filters.
3. Ensure that the electrical supply and frequency are adequate for the operating current required for this specific installation.

WARNING - Before any service or maintenance operations turn off the main power switch.

1. The manufacturer denies any responsibility and warranty shall be void if these installation instructions are not observed.
2. Never switch off the power main supply when unit is operating in the cooling cycle. To switch off the fan coil unit use only the ON-OFF button.
3. This avoids over-flow in the drain pan, by allowing the pump to drain any condensate water due to regulating valve losses when chiller is working.

OPERATING LIMITS

1. Power supply

Volt	Phase	Hz
230	1	50

2. Water circuit

- Minimum entering water temperature: +2 °C
- Maximum entering water temperature: +80 °C
- Water side maximum pressure: 1400 kPa (142 m.w.c)

BEFORE INSTALLATION

The installation site must be established by the system designer or other qualified professional, taking account of the technical requisites and current standards and legislation.

PCE fan coils must be installed by an authorized company only.

PCE fan coils are designed for installation in a false ceiling, for intake of fresh air from outside and for deviation of a small part of the treated air for discharge in a neighboring room.

They must be installed in such a way as to enable treated air to circulate throughout the room and in respect of the minimum distances required for technical maintenance operations.

1. It is advisable to place the unit close to the installation site without removing it from the packaging.
2. Do not put heavy tools or weights on the packaging.
3. Upon receipt, the unit and the packaging must be checked for damage sustained in transit and if necessary, a damage claim must be filed with the shipping company.
4. Check immediately for installation accessories inside the packaging.
5. Do not lift unit by the condensate drain discharge pipe or by the water connections; lift it by the four corners.(Fig.1)
6. Check and note the unit serial number.

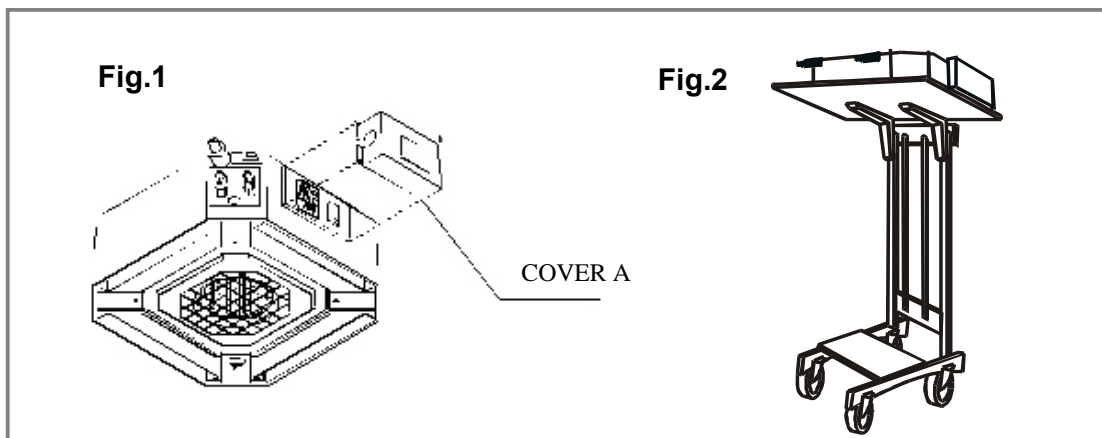

SELECT LOCATION

1. Do not install the unit in rooms where flammable gas or alkaline acid substances are present. Aluminum/copper coils and/or internal plastic components can be damaged irreparably.
2. Do not install in workshops or kitchens; oil vapors drawn in by treated air might deposit on the coils and alter their performance or damage the internal plastic parts of the unit.
3. Installation of the unit will be facilitated by using a stacker and inserting a plywood sheet between the unit and the elevated stacker.(Fig.2)
4. It is recommended to position the unit as centrally as possible in the room to ensure optimum air distribution. (Fig.3) Generally the best louver position is the one which allows air diffusion along the ceiling. Alternatively intermediate positions can be selected.
5. Check that it is possible to remove panels from ceiling in the selected position, to allow enough clearance for maintenance and servicing operations.

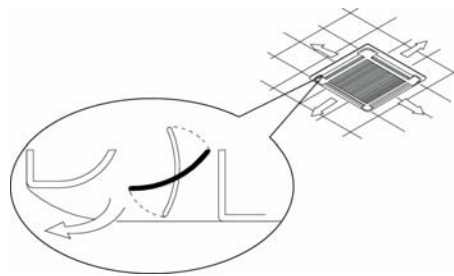

Fig.3

INSTALLATION LOCATION
INSTALL THE UNIT IN A POSITION:

1. Having sufficient strength to carry the weight of the unit.
2. Where the inlet and outlet grilles are not obstructed and the conditioned air is able to blow all over the room.
3. From where condensate can be easily run to drain.
4. Check the distance between the upper slab and false ceiling to ensure the unit will suit the distance. See Fig.4

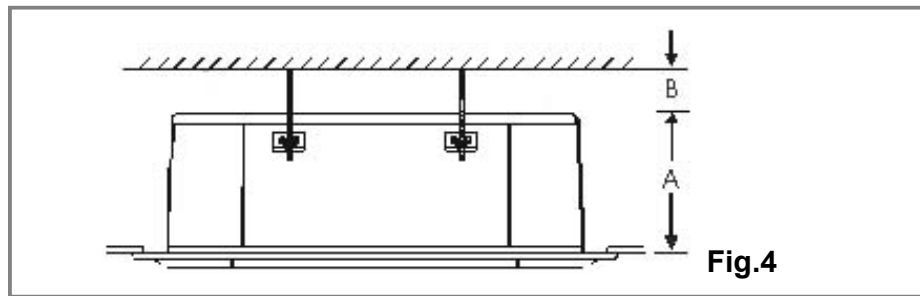

Fig.4

MODEL	A (MM.)	B (MM.)
PCE-06/08/09/10/12/16	290	10 OR MORE

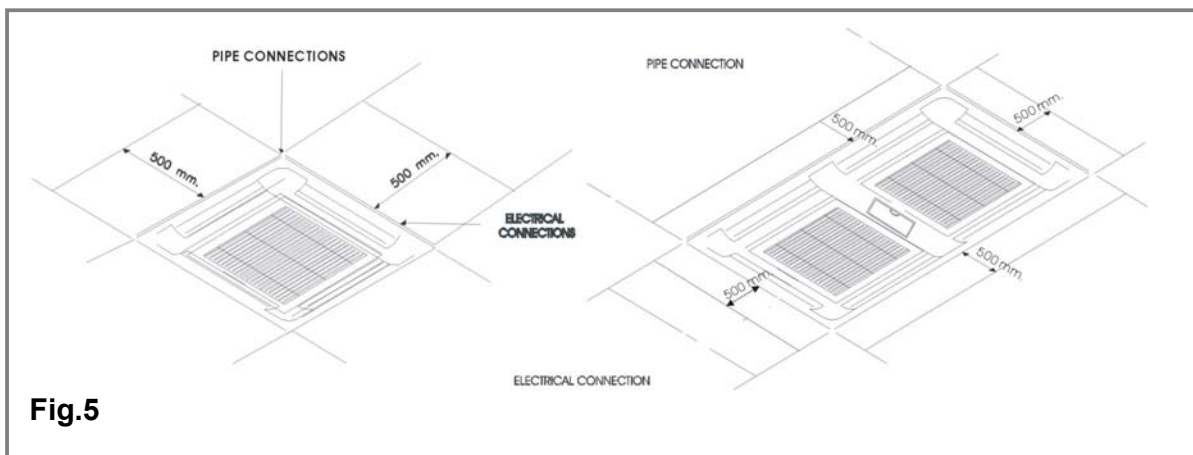

Fig.5

5. Ensure there is sufficient space around the unit to service it. See Fig.5

**INSTALLATION METHOD
CASSETTE UNIT**

Using the installation template open ceiling panels and install the suspension bolts as in Fig.6 below

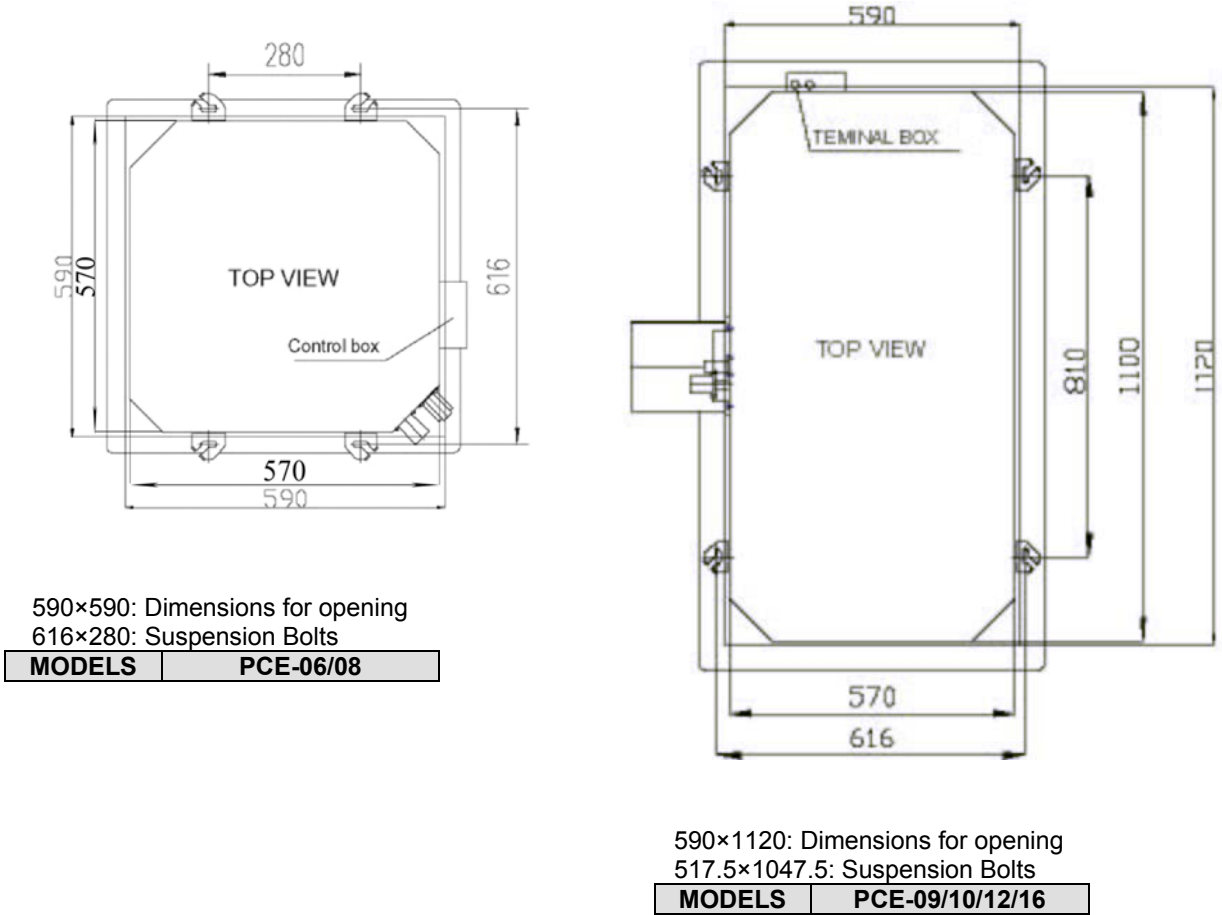
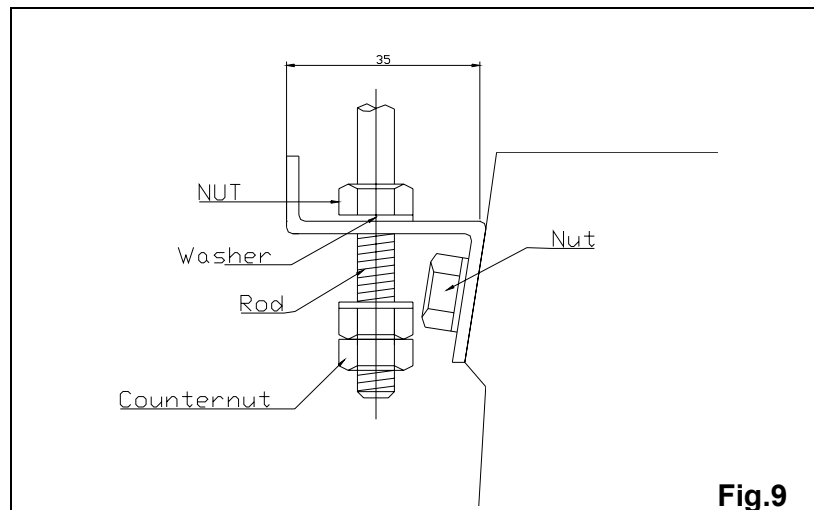
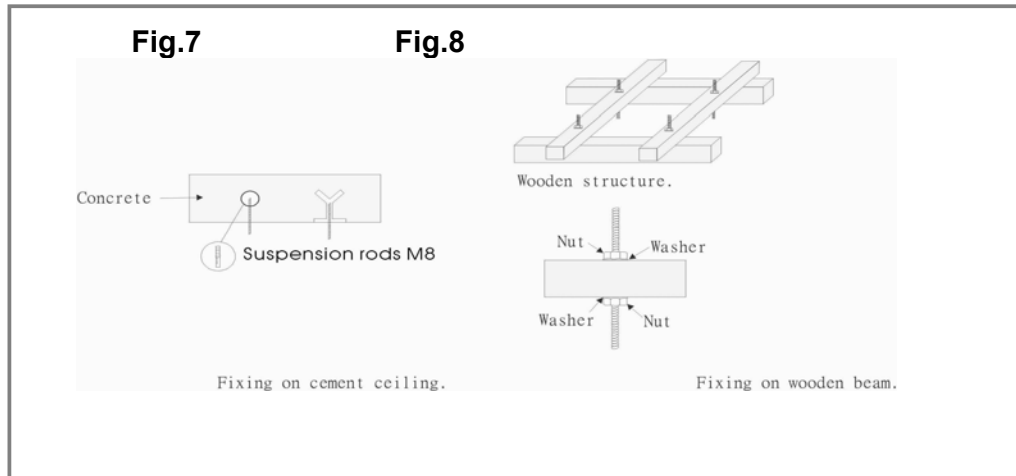

Fig. 6

OPENING DIMENSIONS AND POSITIONS FOR SUSPENSION BOLTS

1. Mark position of suspension rods, water lines and condensate drain pipe, power supply cables and remote control cable.
2. Supporting rods can be fixed, depending on the type of ceiling, as shown in Fig. 7 and Fig.8.
3. Fit suspension brackets supplied with the unit to the threaded rods (Fig.9).
4. Do not tighten nuts and counter nuts; this operation has to be done only after final leveling of the unit, when all the connections have been completed.



5. Ensure the ceiling is horizontally level, otherwise condensate water cannot drain.
6. The casing is fixed to the slab with 4 drop rods. The rods should have two nuts and washers to lock the unit in position. The Cassette brackets will then hook over the washers.
7. When lifting the Cassette into position care should be taken not to lift the unit by the drip tray, which could be damaged.
8. Lift unit (without the air panel) with care by its four corners only. Do not lift unit by the condensate drain discharge pipe or by the piping connections.
9. Incline unit (Fig.10, Fig.11, Fig.13, Fig.14) and insert it into the false ceiling. Insert the rods into the bracket slot.

With minimum height (see table) false ceilings, it might be necessary to remove some T brackets of the false ceiling temporarily.

10. Using a level guide, line up the unit with a spirit level, and keep dimension between the body and the lower part of the false ceiling (Fig.12 Fig.15).
11. Line up the unit to the supporting bars of the false ceiling tightening the nuts and counter nuts of the threaded rods.
12. After connection of the condensate drain piping and piping connections, check again that the unit is level.

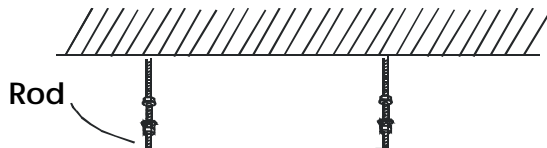

Fig.10

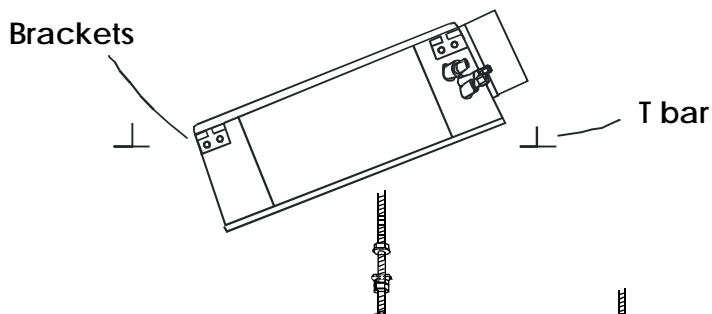

Fig.11

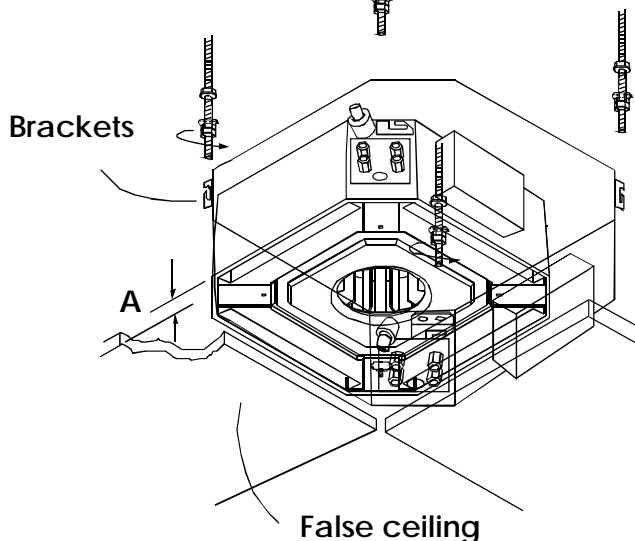

Fig.12

MODEL	PCE-06/08
A (mm.)	3

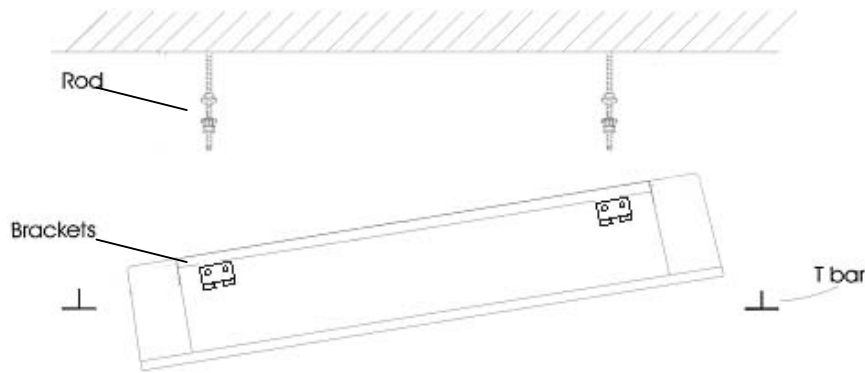

Fig. 13

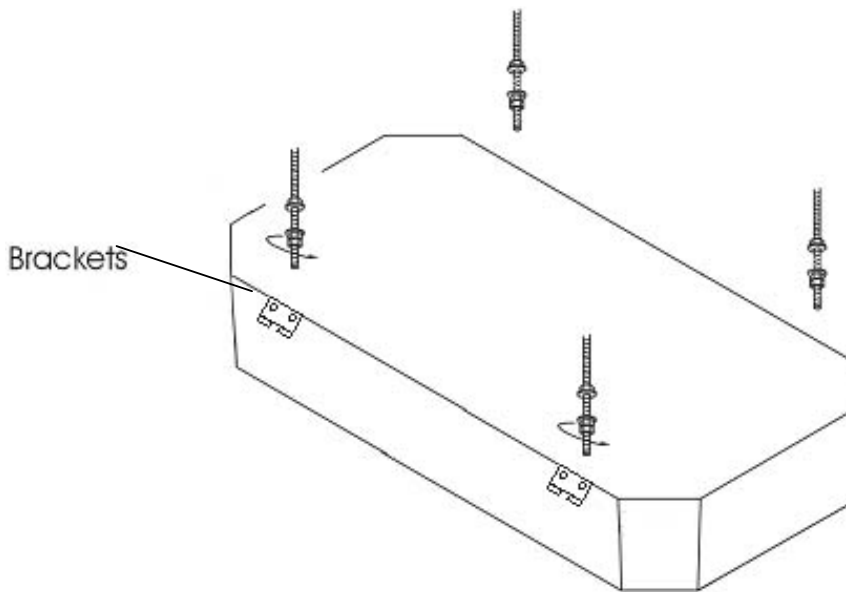

Fig. 14

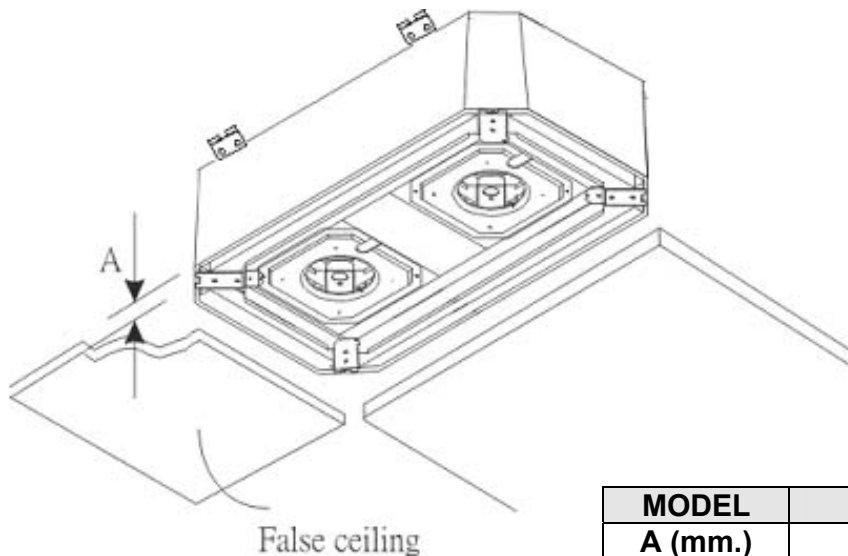

Fig. 15

MODEL	PCE-09/10/12/16
A (mm.)	3

13. The spaces between the unit and ceiling can now be adjusted. Use the drop rods to make the adjustment.
14. Check to ensure the unit is level. The drain will then automatically be lower than the rest of the drip tray.
15. Tighten the nuts on the suspended rods.

**DRAIN PIPE WORK
INDOOR UNIT**

1. The unit is fitted with a condensate pump with a 500 mm. lift.
2. The unit is provided with 22 mm. bore flexible hose 300 mm. long.
3. The flexible hose should be fitted into a 22 mm O/S Φ . polyvinyl tube and sealed. The drain must be installed with a downward slope.
4. On completion the drain line should be insulated.

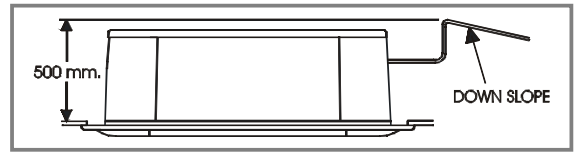
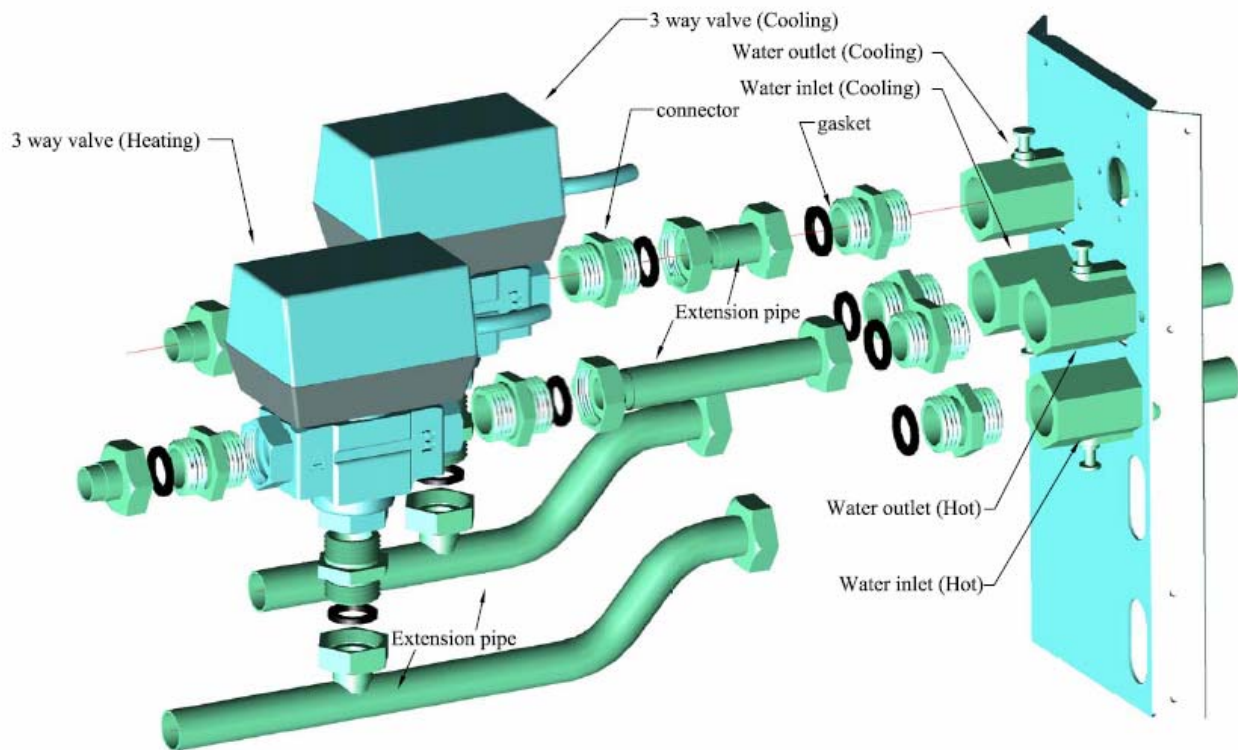

Fig. 16

WATER CONNECTIONS

1. Water connections are fixed to the unit body to avoid breaks when pipes are connected to valve assemblies; it is advisable to tighten the connection with a spanner.
2. The upper coil connection is supplied with air purge screw, the lower connection with water purge screw, suitable for 8mm. wrench or screw-driver.
3. Coil is partially drainable; it is advisable to blow air into the coil for complete drainage.

PIPE CONNECTION KIT (OPTION)



PIPE CONNECTION DIMENSIONAL DRAWINGS

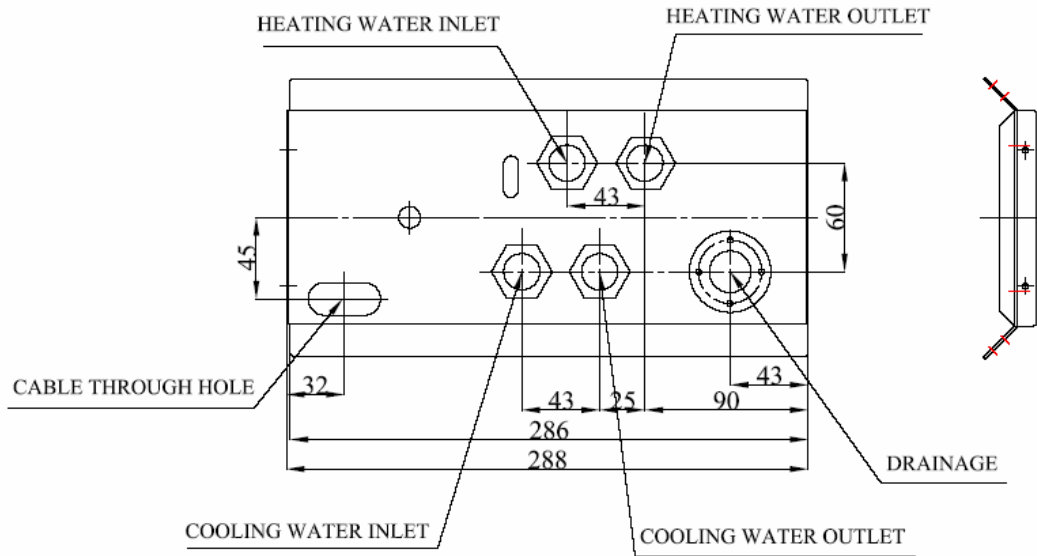

PCE-06/08-PS

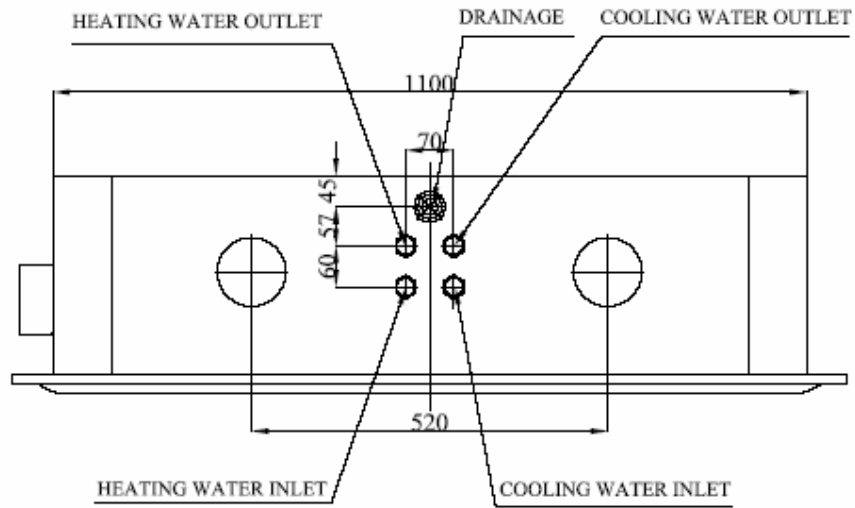

PCE-09/10/12/16-PS

EXTENDED DRAIN PAN ACCESSORY

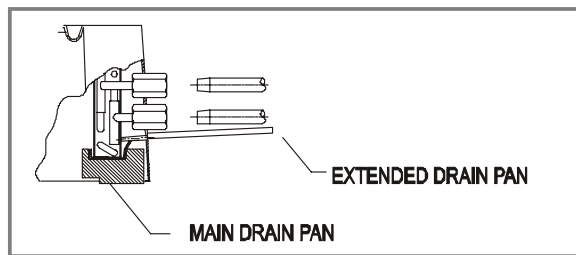
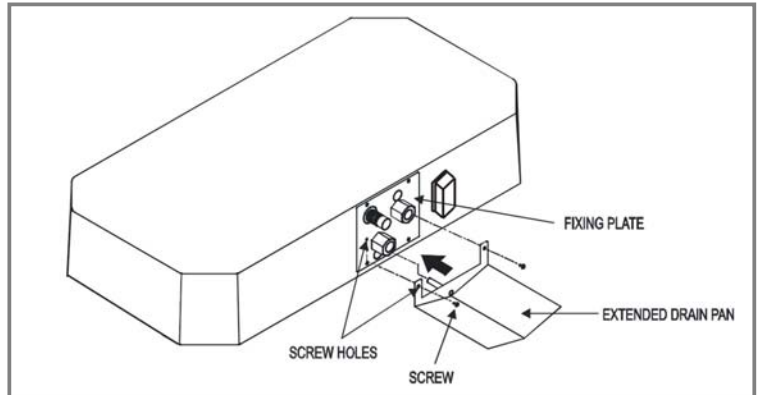
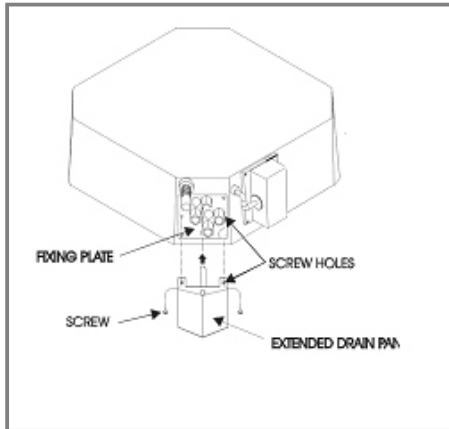

INSTALLATION PROCEDURES

1. Align the two (2) screw holes in the fixing plate to the two (2) holes in the external drain pan.
2. Make sure the drain pan is horizontal.
3. Tighten the two screws and making sure the external drain pan is installed flush with the fixing plate.

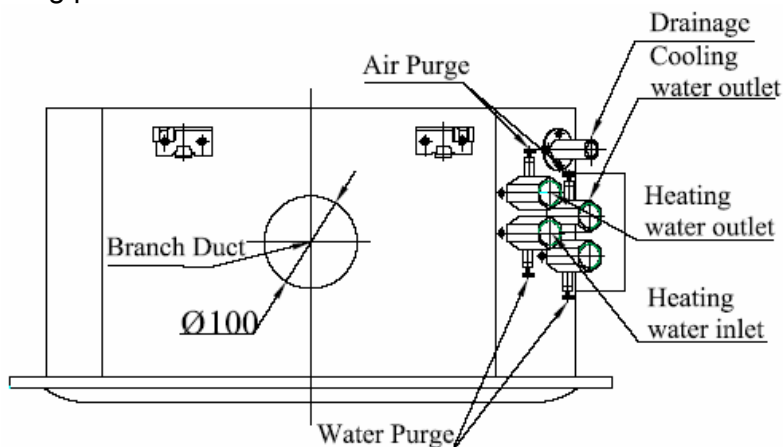

When the installation is completed, it is necessary to wrap connecting pipe with insulation to prevent leakage to ceiling tile.

ELECTRICAL WIRING

1. Remove cover A and install the connection wires.
2. After wiring is complete install cover A.

INTERCONNECTING WIRING

We recommend that screened cable be used in electrically noisy areas.

1. Always separate low voltage (5VDC) signal wires from power line (230 VAC) to avoid electro-magnetic disturbance of control system.
2. Do not install the unit where electromagnetic waves are directly radiated at the infra red receiver on the unit.
3. Install the unit and components as far away as is practical (at least 5 meters) from the electromagnetic wave source.
4. Where electromagnetic waves exist use shielded sensor cable.
5. Install a noise filter if any harmful noise exists in the power supply.

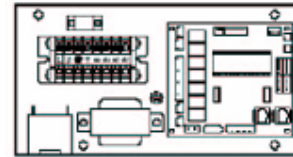
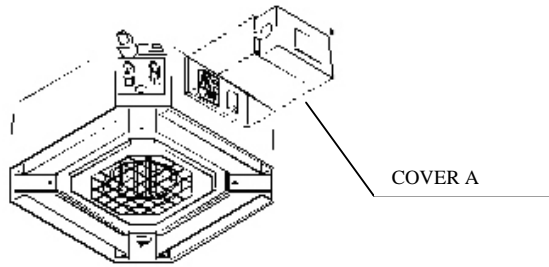

TERMINAL BLOCK
PCE-06/08

Fig. 15

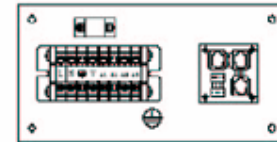
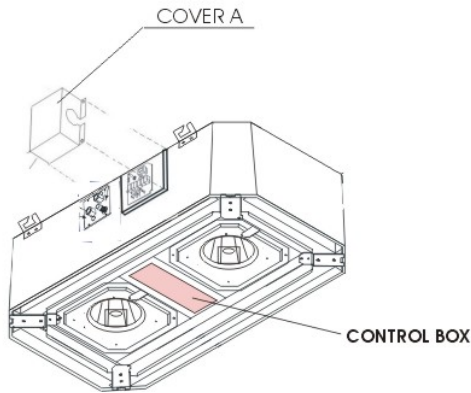

TERMINAL BLOCK
PCE-09/10/12/16

Fig. 16

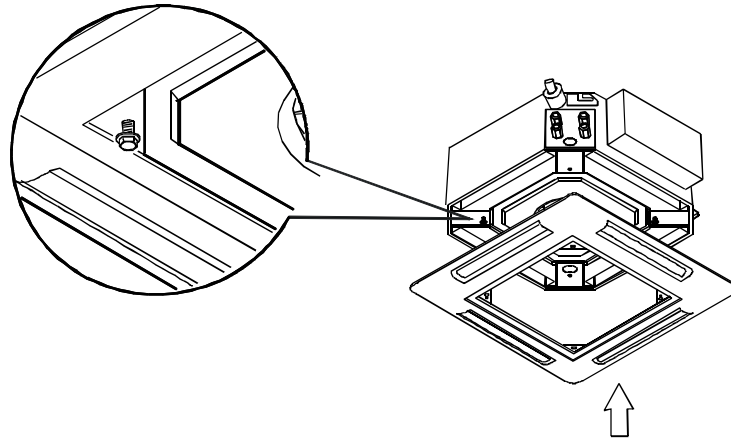

Fig. 17

MOUNTING FRONT PANEL ASSEMBLY

1. Remove return grille from front panel.
2. Move the front panel to case.
3. Tighten 4 screw as shown in Fig 17,18

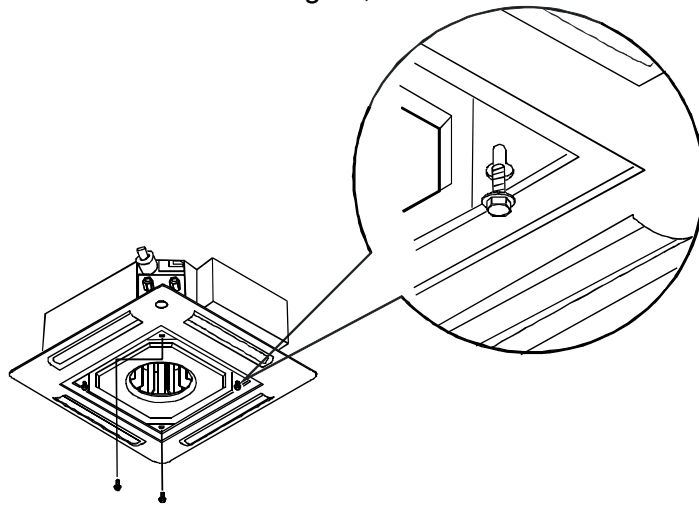

Fig. 18

FILTER REMOVAL

1. Unlock the two fasteners on the front panel.
2. Open the grille downward with care.
3. Pull the filter out along the slot.
4. Clean the filter and reassemble.

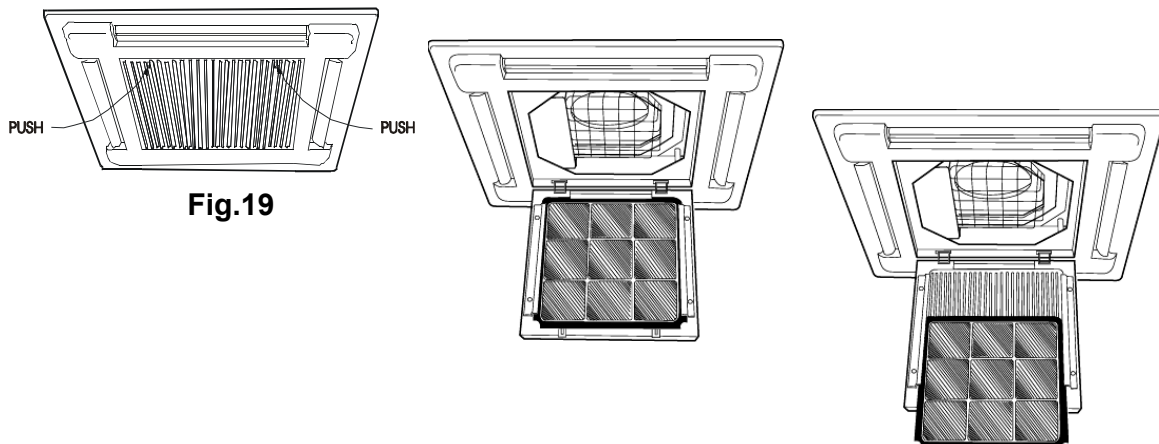

Fig.19

PRELIMINARY CHECKS BEFORE START-UP

1. The unit should not be started up until the system piping has been cleaned and all the air has been purged.
2. Check condensate drain pipe slope.
3. After you have connected the main power supply to the cassette unit, it is necessary to check the good function of the condensate water pump which is installed inside.
Due to transport vibration, it might be possible that the float switch is hung up and the pump might not work in the correct way. For this reason, you have to do the following, to ensure good functioning of the unit:
 - a. Install the cassette unit in an absolute horizontal position.
 - b. Fill the internal drainpan (manually) with enough water to ensure the drain pump is working.
 - c. You can fill the drainpan by pouring water through the external drainpan.
If everything is correct, the water will be pushed out into the pipe work you have installed. If the valve does not open, you have to make sure the float switch is not hung up inside the unit and you will have to loosen it by hand.
4. Make sure that air filter is clean and properly installed.
5. Ensure that voltage and current values correspond with the unit nameplate values; check electrical connections.
6. Verify that air outlets are not closed.

MAINTENANCE

1. Before performing any service or maintenance operations, turn off the main power switch.
2. The air filter is made of acrylic fiber and is washable in water. To remove filter simply open the intake grille by releasing the two catches. See Fig.19 and the section filter removal.
3. Check the filter periodically and before the operating season; clean or replace as necessary.

PROLONGED UNIT SHUT-DOWN

1. Prior to restarting the unit:
2. Clean or replace the air filters.
3. Check and remove any obstruction from the external drain pan and the internal drain pan.

EXTRA MAINTENANCE

1. The electrical panel is easily accessible by removing the cover panel.
2. The inspection or replacement of internal components such as; heat exchanger coil, condensate
3. Drain pump, float switch, involves the removal of the condensate drain pan.
See Fig.20-25.
4. During the removal of the condensate drain pan protect the floor under the unit with a plastic sheet from condensate water that could be spilled.
5. Remove fixing screws of the drain pan fixture and remove condensate drain pan with care.

The appliance is intended to be maintained by qualified service personnel and located at a height of not less than 2.5m.

PCE-06/08-PS

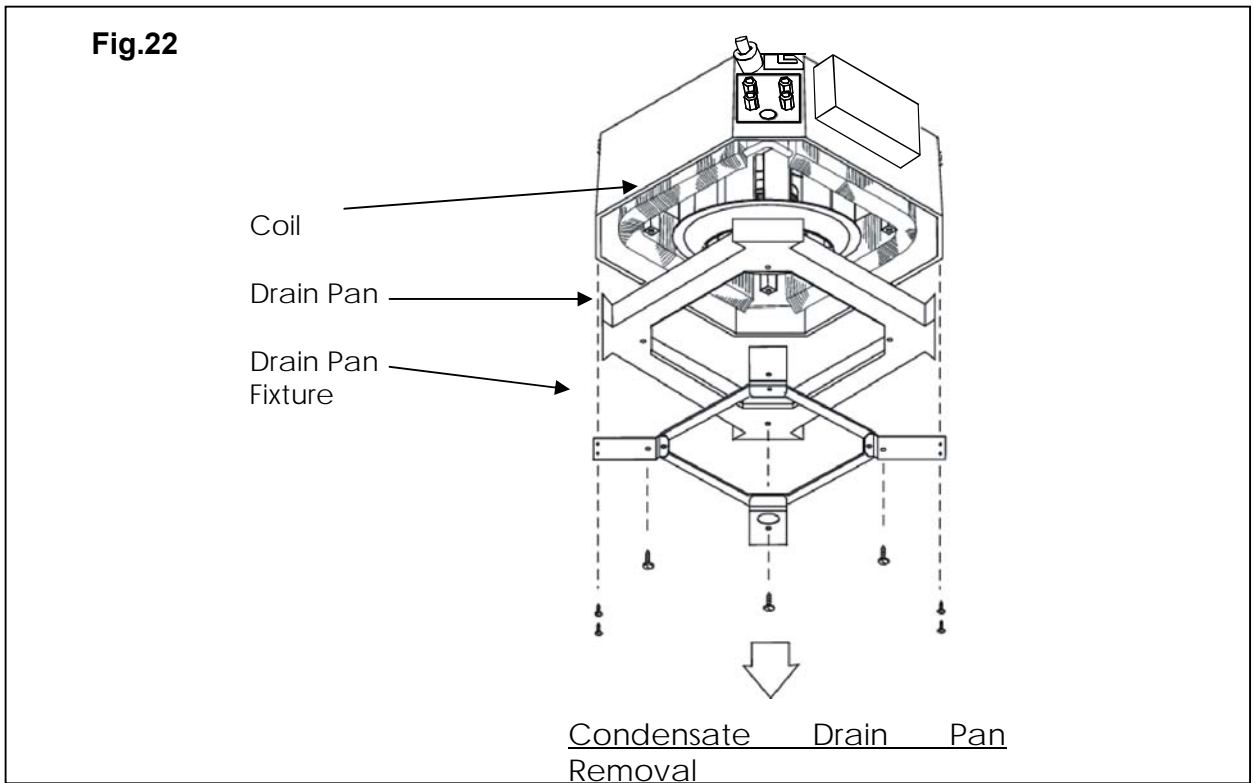
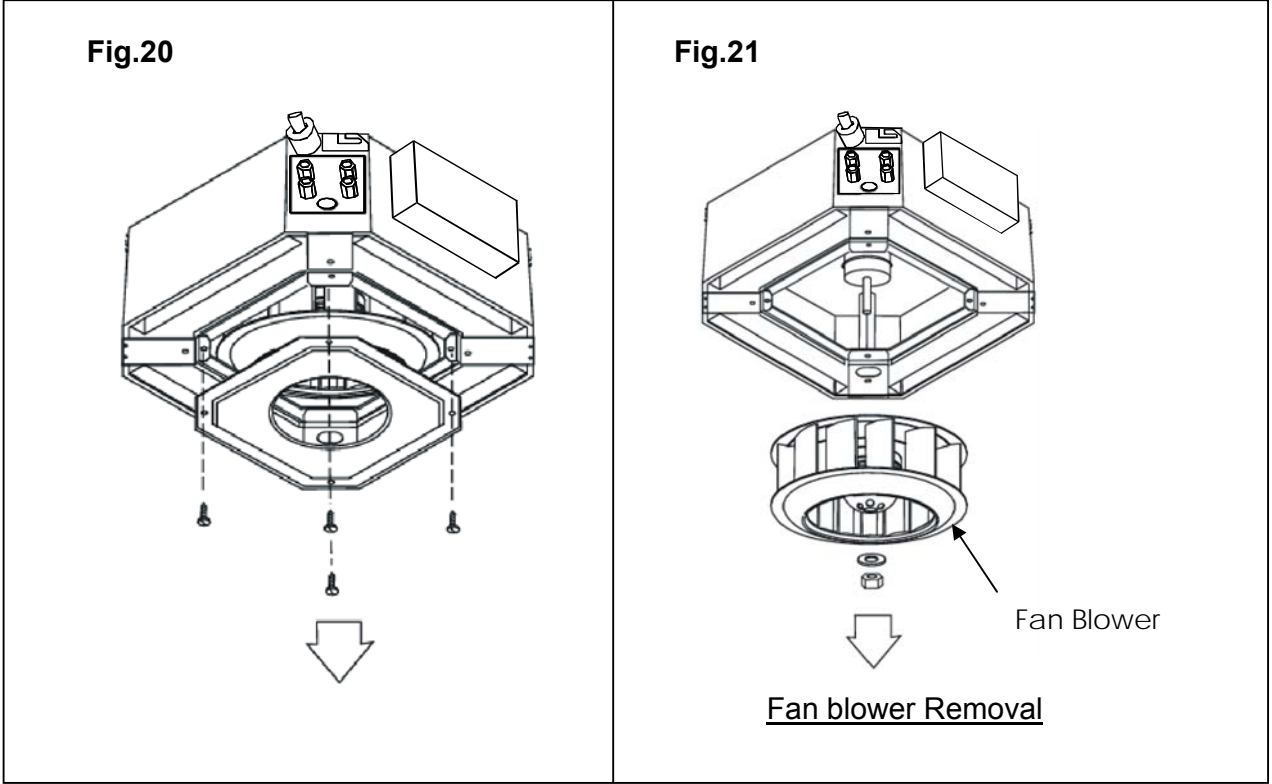

PCE-09/10/12/16-PS

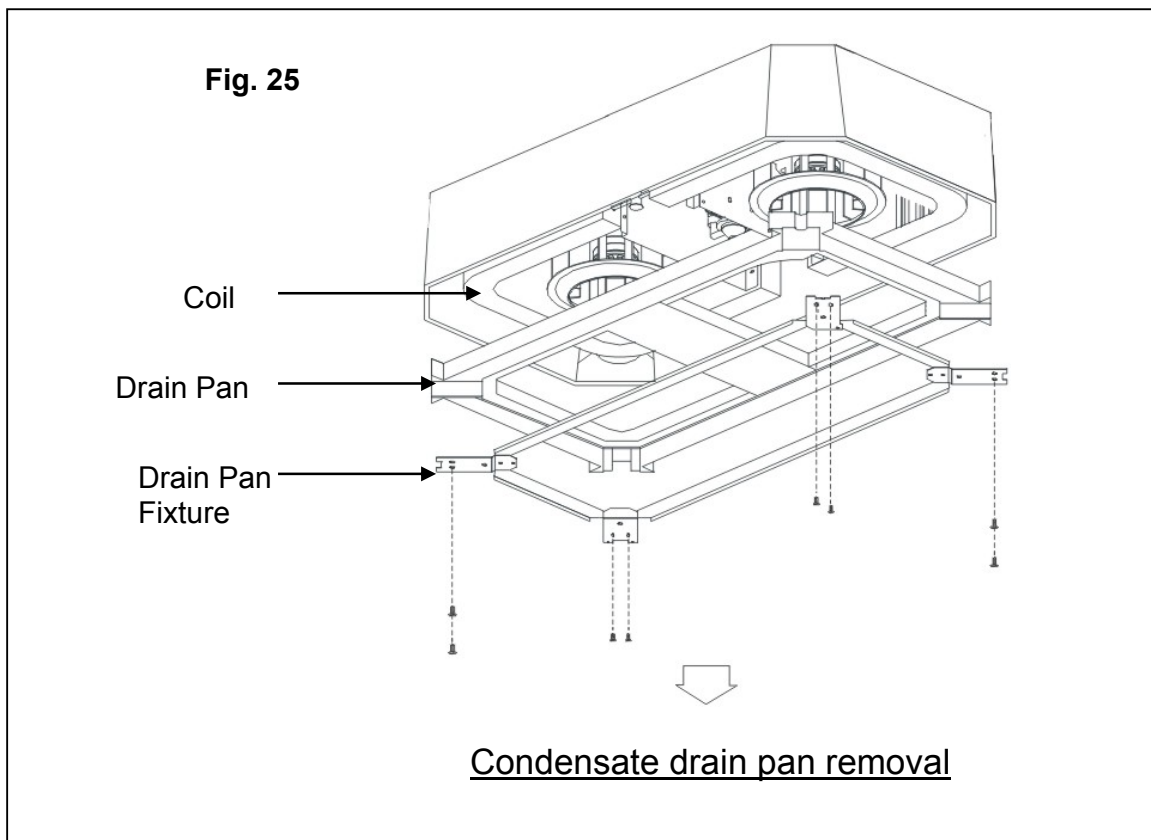
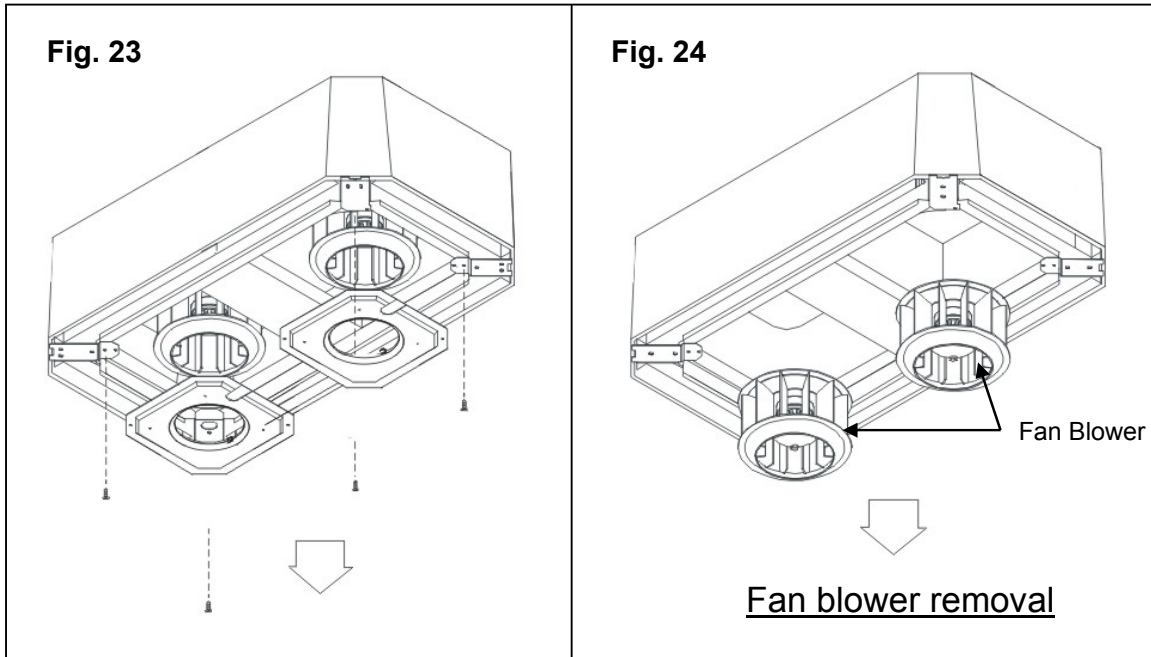

FRESH AIR RENEWAL AND BRANCH DUCTING

1. The side opening allows separate ductwork to be installed for outside air intake and branch ducting. See Fig.26
2. Cut and remove anti-condensate insulating material.
3. Install your flanges and conduits to casing. Conduit can be flexible polyester with spring core or corrugated aluminum externally coated (dia.4 in.) with anti-condensate material (fiberglass 12-25 mm thickness).

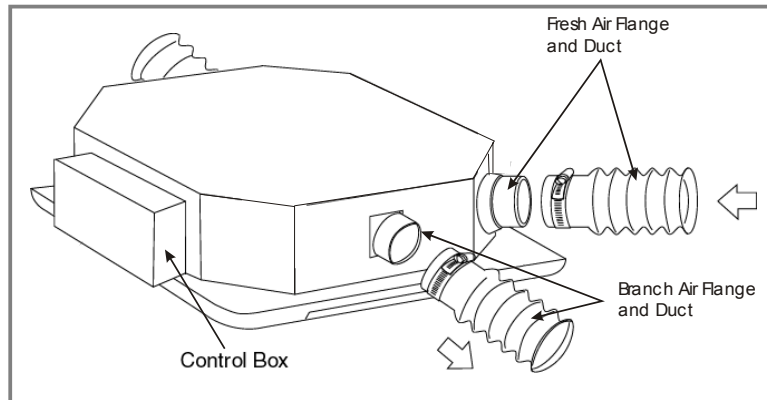
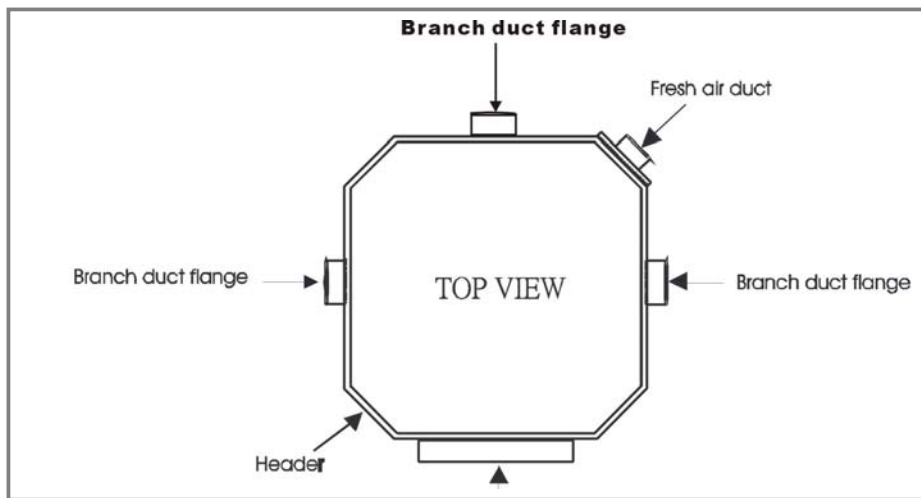

Fig. 26

Fresh air - There is one (1) opening for connecting a fresh air duct for PCE-06-08, There are two (2) openings for connecting fresh air ducts for PCE-09-10-12-16.

Branch air - PCE-06-08 : Two(2) openings each.
 PCE-09-10-12-16 : Four (4) openings each.

Order flanges (spigots) and blanking plates as accessories separately.



NOTE:

- Branch duct flange (Optional part)
- Fresh air duct flange (Optional part)
- Blanking plate (Optional part)

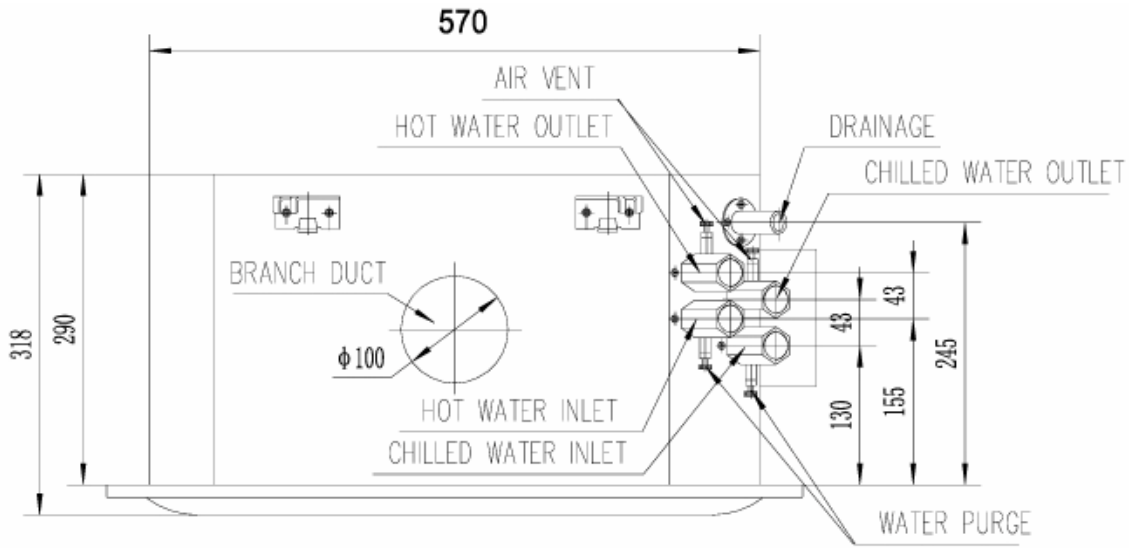

PCE-06/08

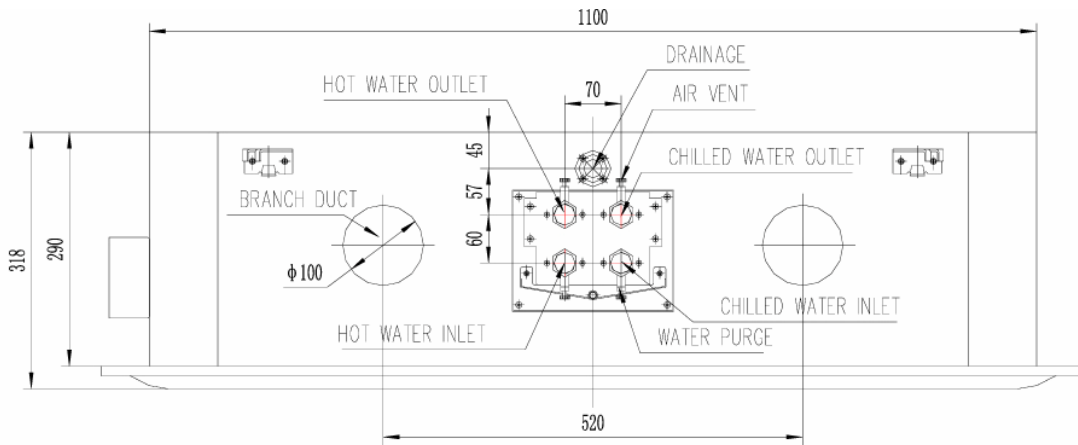

PCE-09/10/12/16

BRANCH DUCT AND FRESH AIR DUCT INSTALLATION

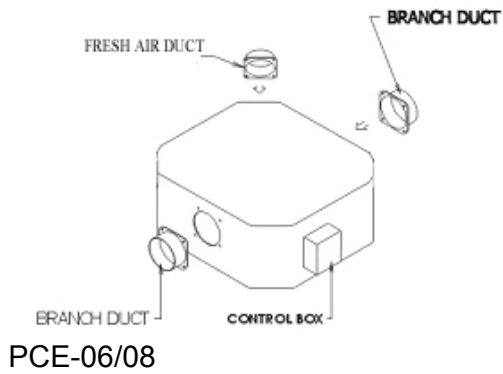

PCE-06/08

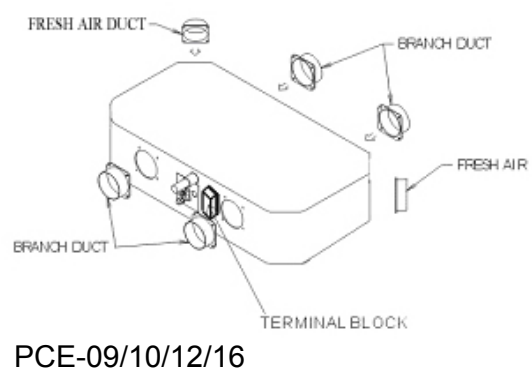

PCE-09/10/12/16

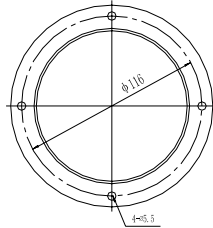
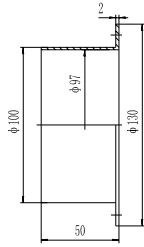

BRANCH DUCT DIMENSION

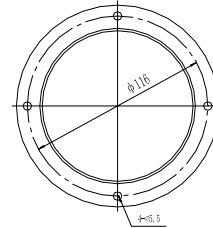
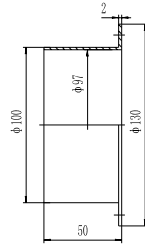

FRESH AIR DUCT DIMENSION

MODEL	BRANCH DUCT		FRESH AIR	
	Dia(mm)	QTY	Dia.(mm)	QTY
PCE-06/08	100	2	100	1
PCE-09/10/12/16	100	4	100	2

BRANCH DUCT AND FRESH AIR DUCT POSITIONS

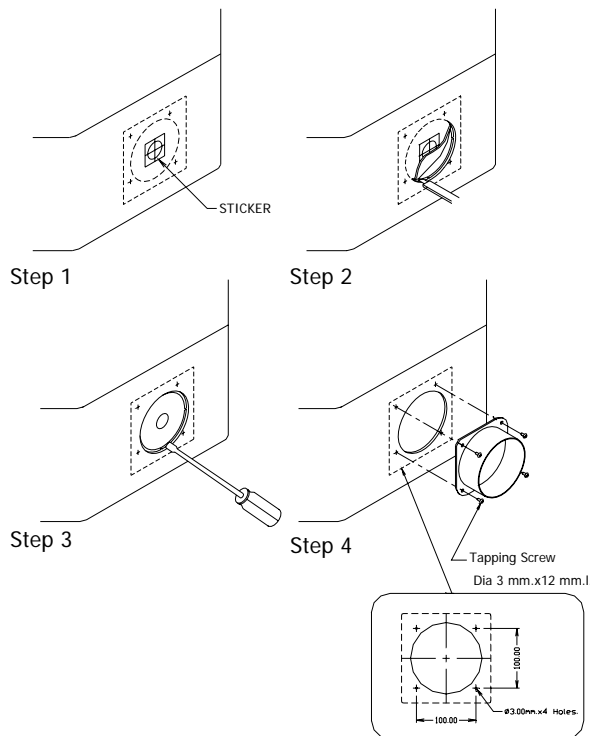

1. Look for the yellow sticker on the casing for location of branch duct or fresh air intake connections.
2. The sticker is at the center of a knock out hole underneath the casing insulation. Use a cutter and follow along the pre-cut circular marking as shown and trim off the insulation.
3. Knock out the pre-cut hole.
4. Connect the flange on to the opening with $\Phi 3$ mm. x 12 mm. tapping screws.

BLANKING PLATES – See the following diagram and installation method.

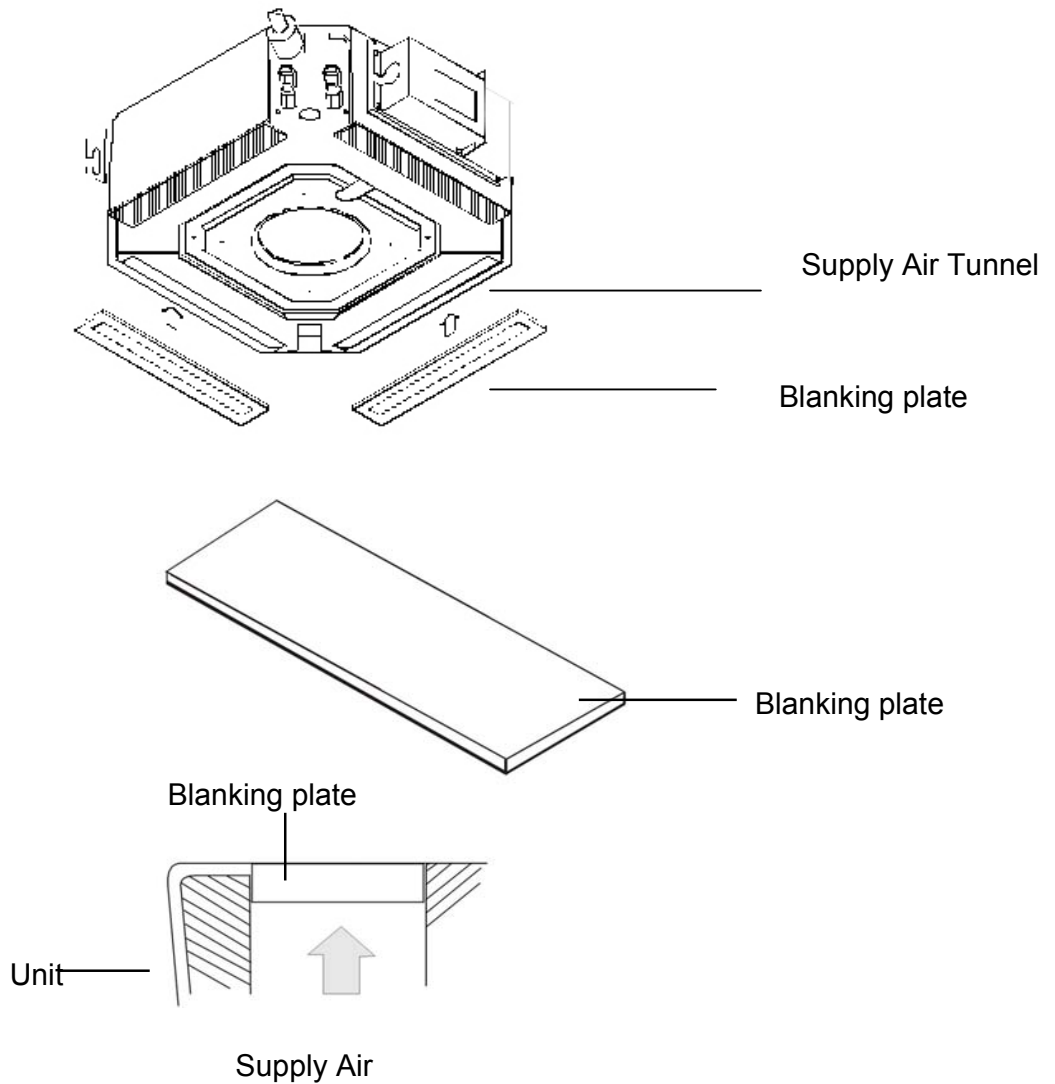

HOW TO INSTALL

1. Peel off the cover paper to expose adhesive surface of the blanking plate.
2. Apply blanking plate on the supply air tunnel to cover the opening.
3. Press on the attaching area to firmly seal it.

DIMENSIONAL DRAWINGS

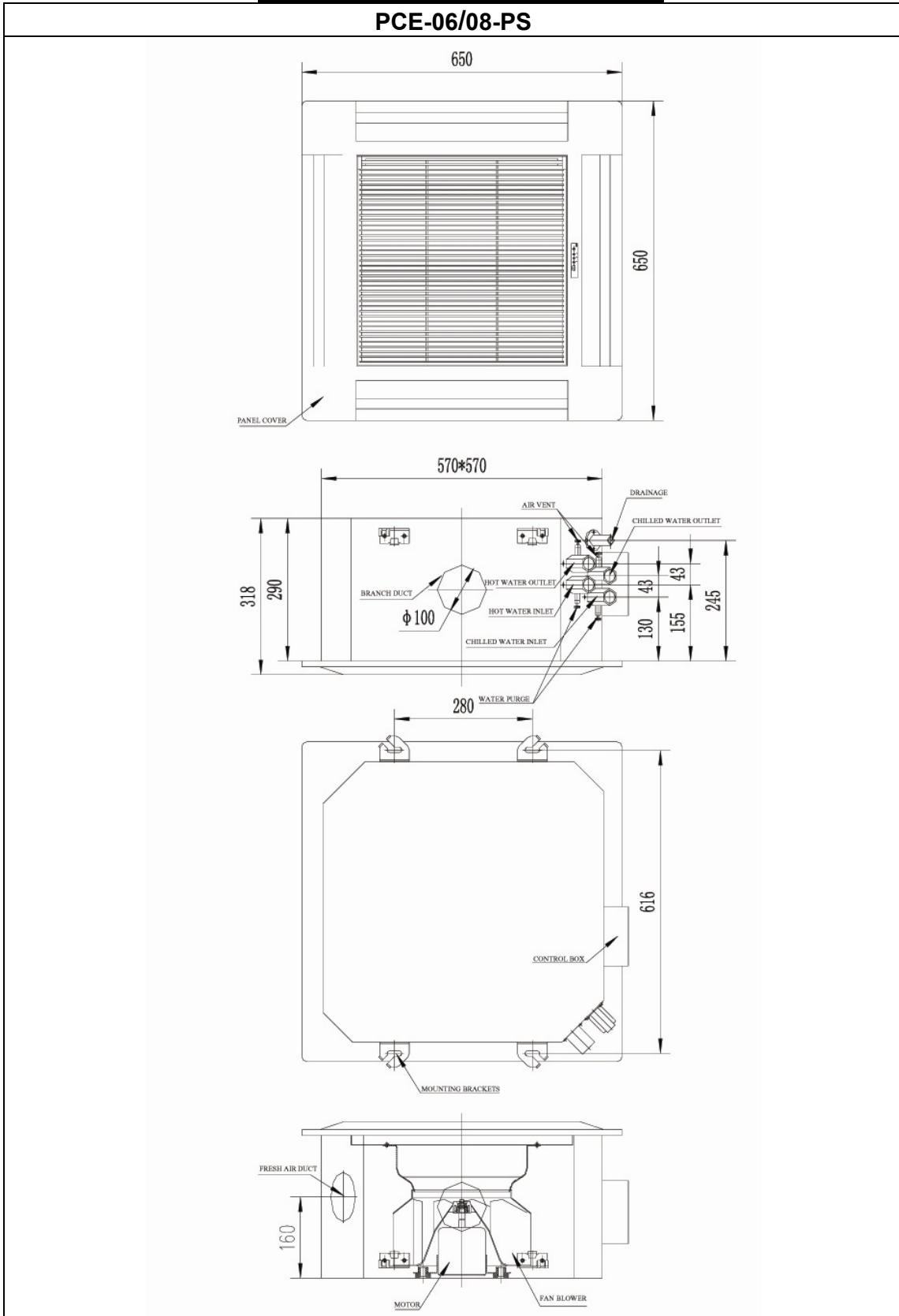

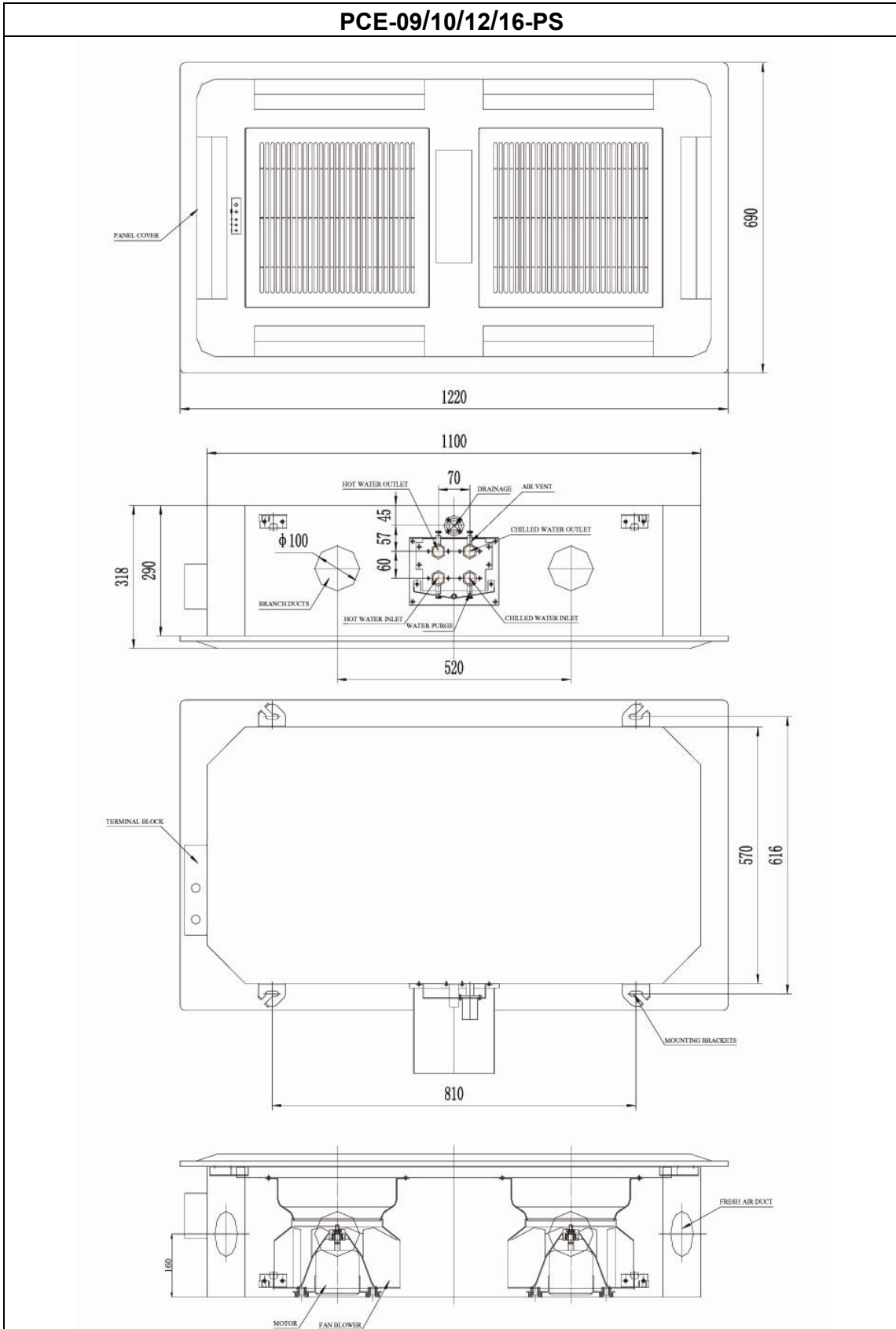

EXPLODED VIEW DRAWING

PCE-06/08-PS

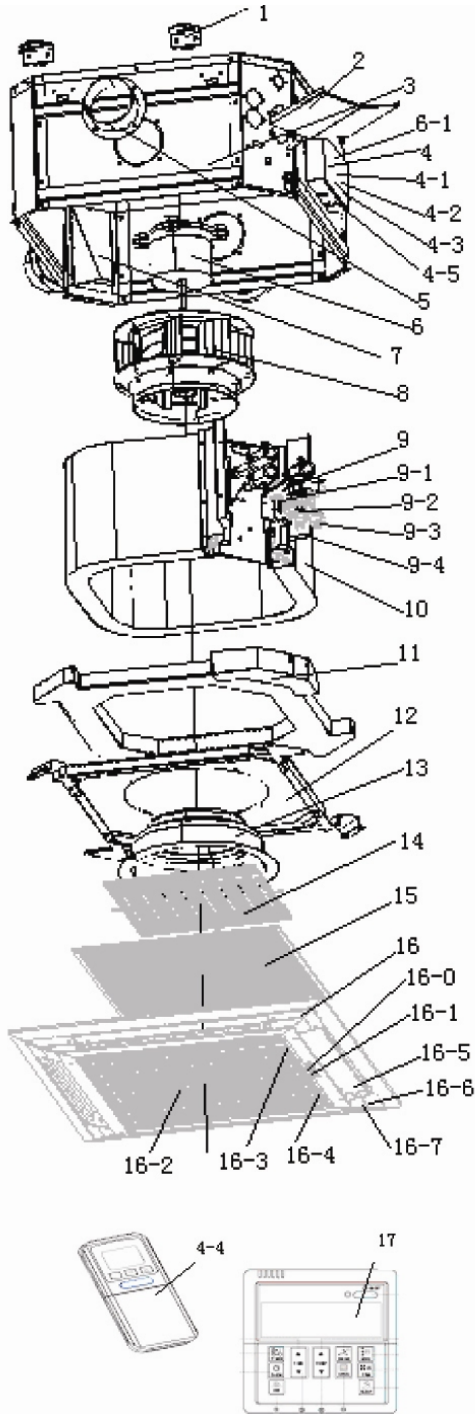

- 1-Mounting brackets
- 2-External drain pan
- 3-Casing
- 4-Control box
- 4-1- Main PCB
- 4-2-Transformer
- 4-3-Terminal block
- 4-4-Remote handset
- 4-5-Wire clip
- 5-Branch duct
- 6-Fan motor
- 6-1- motor capacitor
- 7- Fresh air outlet
- 8-Fan blower
- 9-Drain pump assembly
- 9-1- Drain pump fixture
- 9-2- Drain pump
- 9-3-Drainage tube
- 9-4- Float switch
- 10-Coil
- 11-Drain pan
- 12-Drain pan fixture
- 13-Venturi
- 14-Shield
- 15-Air filter
- 16-Cover panel assembly
- 16-0- Receiver display
- 16-1-Receiver label sticker
- 16-2-Grille
- 16-3-Bolt (Left)
- 16-4-Bolt (Right)
- 16-5-Swing Louver
- 16-6-Stepping motor
- 16-7-Fan bearing
- 17- Wire wall pad

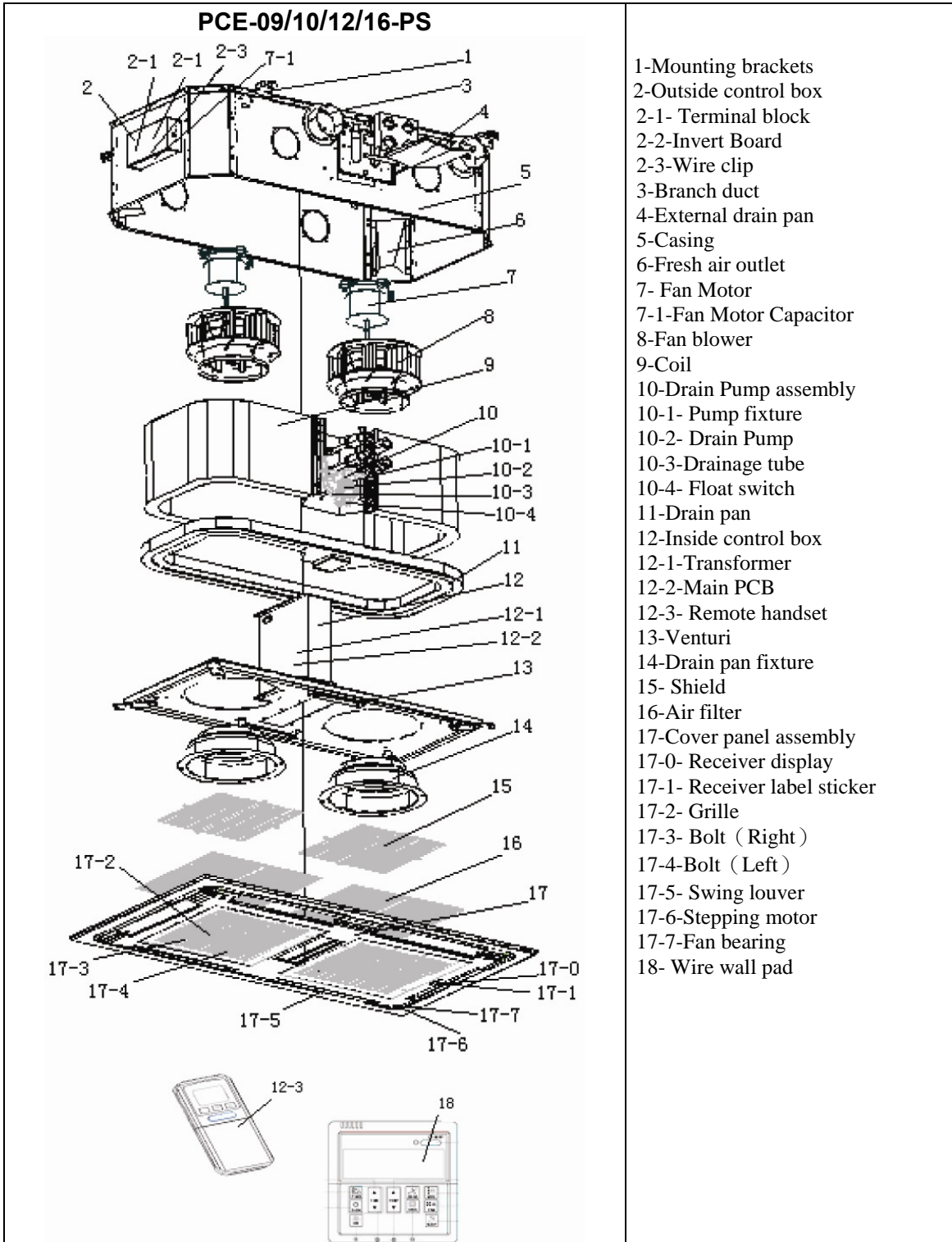

REMOTE CONTROL HANDSET

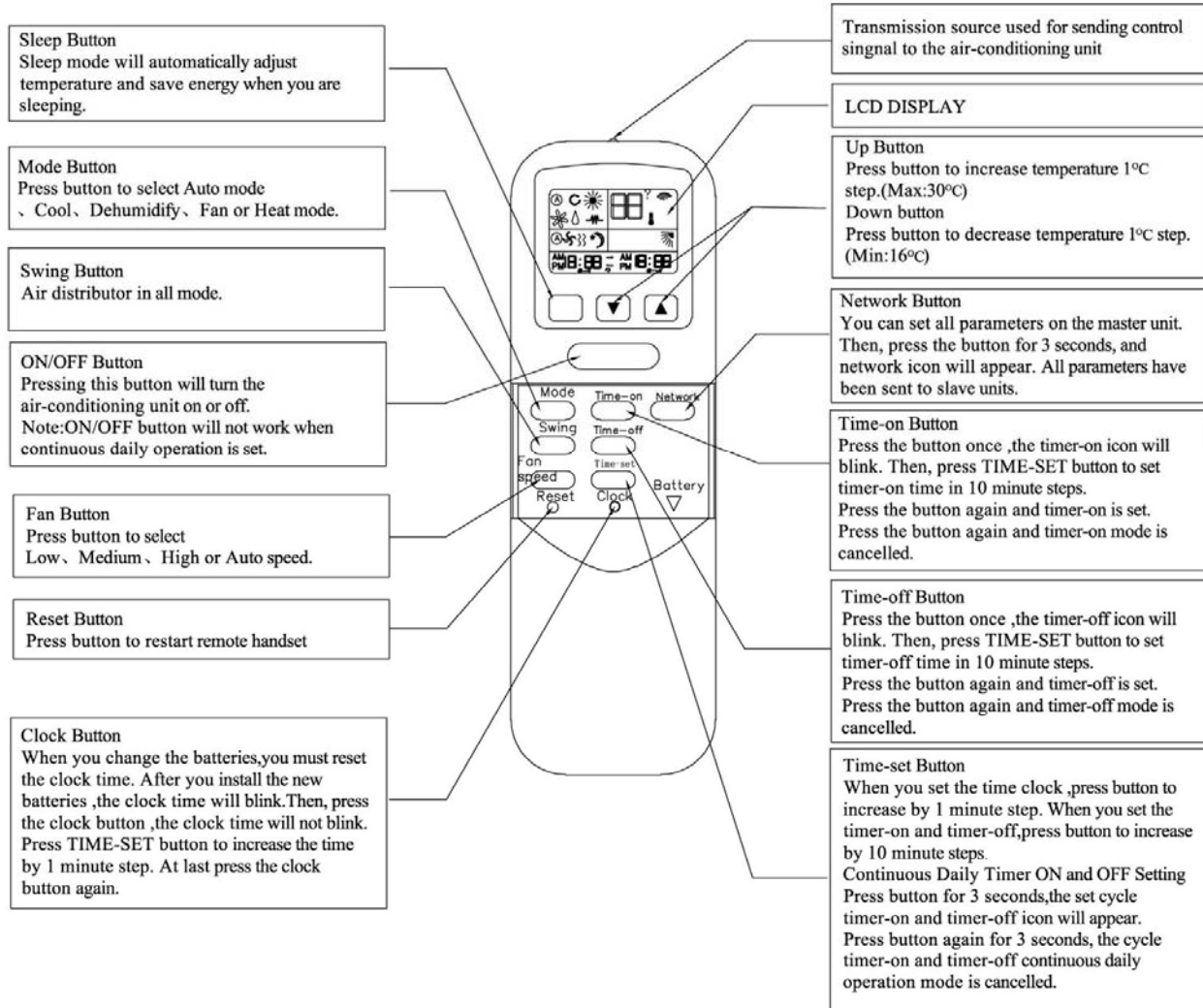

LCD DISPLAY

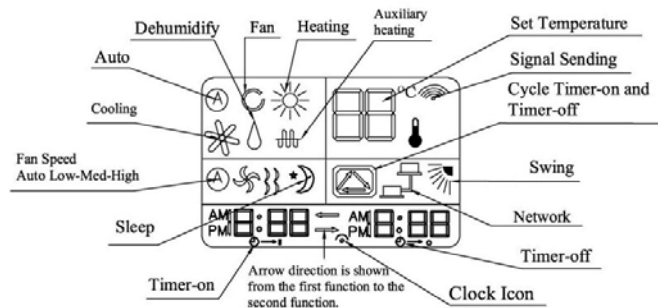

WIRED WALL PAD

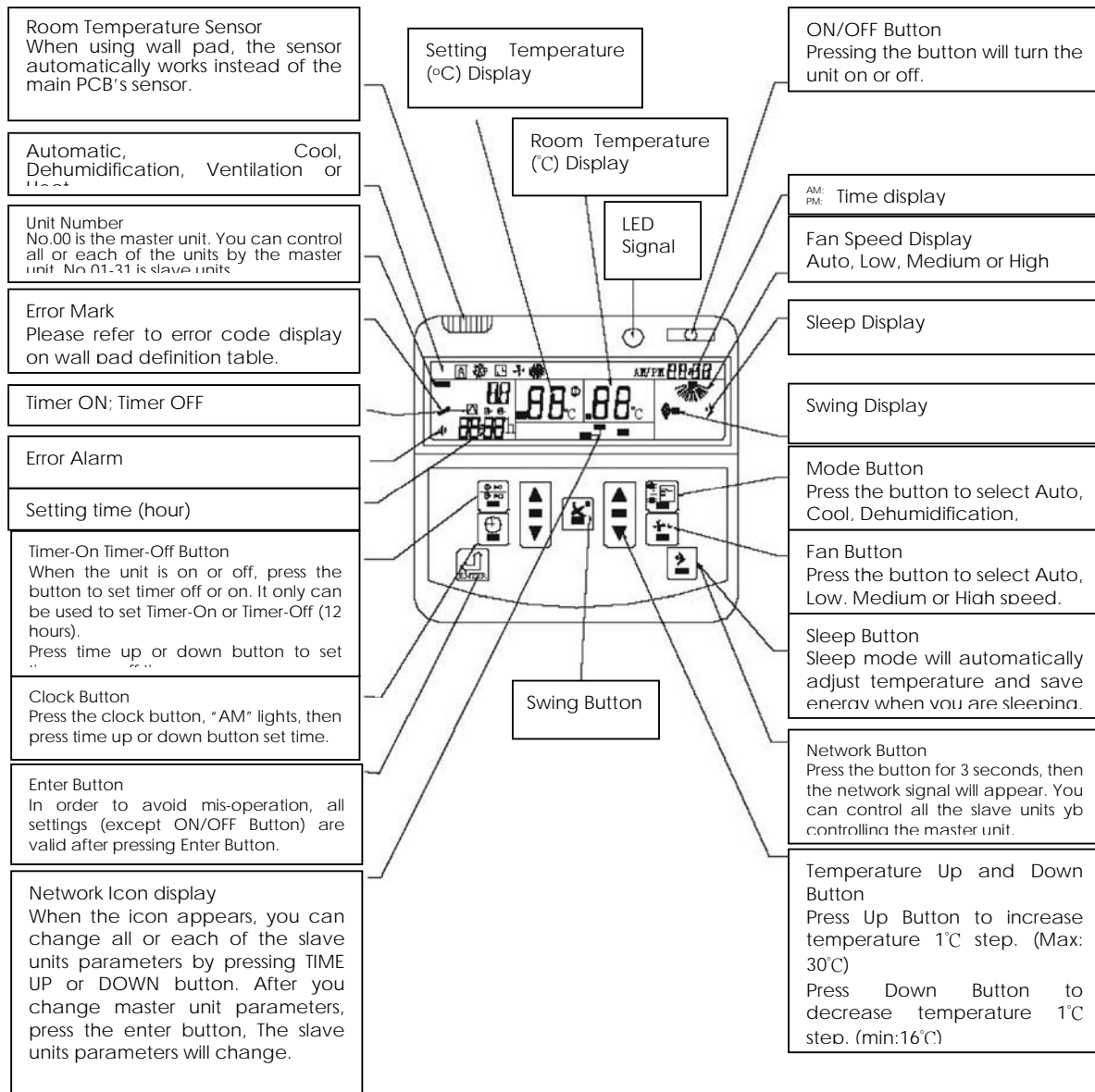

FOR SETTING MASTER – SLAVE USING WALL PAD:

SEE 2.A.3 MASTER – SLAVE INSTALLATION (PAGE 34)

CONTROLS SPECIFICATION

4 PIPE HOT AND CHILLED HYDRONIC CASSETTE WITH MOTORIZED VALVE, MASTER – SLAVE CONTROL

1. ABBREVIATIONS

Ts = Setting temperature

Tr = Room air temperature sensor

Ti1 = Indoor coil temperature sensor for heating

Ti2 = Indoor coil temperature sensor for cooling

AUX1 = Auxiliary contact for heating

AUX2 = Auxiliary contact for cooling

MTV1 = Motorized valve for heating

MTV2 = Motorized valve for cooling

2. CONTROL SYSTEM OPERATION

2.A MASTER AND SLAVE UNIT FUNCTION

The wired wall pad can be set either as a master unit or slave unit.

2.A.1 MASTER UNIT FUNCTION

- a) The master unit sends data on its setting to the slave unit.
- b) The master unit settings are Unit ON/OFF, Mode, Fan Speed, Set Temperature, Swing Function, and Sleep Function.

2.A.2 SLAVE UNIT FUNCTION

- a) The slave unit receives data on its settings from the master unit.
- b) The slave unit is allowed to change to a locally desired setting by local controller as long as there are no subsequent changes to the settings of the master unit.
- c) The slave units can be set individually for timer on and off function.

2.A.3 MASTER – SLAVE INSTALLATION

- a) **HANDSET AS MASTER CONTROL UNIT:**
 - Connect all the units with shielded wires as a group.
 - Select the master unit and short/close the bridge JP0 on the main PCB using the black jumper.
 - Ensure slave main PCBs do not have black bridges on JP0.
 - Power up the units by connecting the main power supply.
 - Set the master by using the handset to set the operation parameters (mode, fan speed, etc.) for the slave units to follow.
 - Press the “network” button until the network icon appears in the LCD screen of your handset. Release the network button and all the information will be sent to the slaves.
 - You will hear beeping sounds confirming that the information is received by the slaves. See (e) below.
 - All units should work according to the settings in the master unit.

b) WALLPAD AS MASTER CONTROL UNIT:

- Connect all the units with shielded wires as a group.
- Open the wall pad plastic at the back.
- Cut all the bridges (0, 1, 2, 3, 4, 5) on the back of the wall pad PCB so that they are open. See diagram below:



- Close the wall pad plastic box at the back.
- Select the master unit and connect to the wall pad.
- Power up the units by connecting the power supply. Ensure the number 00 is showing in the LCD of the master wall pad.
- Ensure slave main PCBs do not have jumpers on JP0.
- Using the master wall pad set the operation parameters (mode, fan speed, etc.) for the slave units to follow.
- Press the “SLEEP” button for 3 seconds on the wall pad or until the communication icon appears.
- Select “ALL” slaves by pressing the time up/down button and then press “ENTER”. All the master wall pad information has been sent to the slaves
- You will hear beeping sounds confirming the information is received by the slaves. See (e) below.
- All units should work according to the settings in the master unit.

Note: If you change a set parameter in the wallpad (step 8) please repeat steps 9 and 10 again to send the information to the slaves.

c) Slaves will function with or without wall pad or handset.

d) Connect master to slave units with shielded wire. Use 4-core cable and one-to-one configuration.

e) When MAIN POWER SUPPLY is ON:

- With motorized valve: The master unit will respond with 3 beeps.
The slave unit will respond with 1 beep.
- Without motorized valve: The master unit will respond with 4 beeps.
The slave unit will respond with 2 beeps.

2.B. AIR CONDITIONER ON/OFF

There are 3 ways to turn the system on or off:

1. By ON/OFF button on the handset or wired wall pad.
2. By programmable timer on the handset or wired wall pad.
3. By manual control button on the air conditioner.

2.C. POWER ON SETTING

When power on signal is received by the air conditioner, the Mode, Fan Speed, Set Temperature and Swing settings will be the same as the last handset settings before the last power off.

2.D. COOL MODE

1. If $T_r \geq T_s + 1^\circ\text{C}$, cool operation is activated. MTV2 is turned on. AUX2 is closed. Indoor fan runs at set speed.
2. If $T_r \leq T_s$, cool operation is terminated. MTV2 is turned off. AUX2 is opened. Indoor fan runs at set speed.
3. The range of T_s is 16 to 30 °C.
4. Indoor fan speed can be adjusted for low, medium, high and auto.
5. When turned on, MTV2 requires 30 seconds before it is fully open.
6. When turned off, MTV2 requires 120 seconds before it is fully closed.
7. When the unit is turned off, indoor fan will delay for 5 seconds before it is turned off.

2.D.1. LOW TEMPERATURE PROTECTION OF INDOOR COIL

1. If $T_i \leq 2^\circ\text{C}$ for 2 minutes, MTV2 is turned off. AUX2 is opened. If indoor fan is set for low speed, it will run at medium speed. If it set at medium or high speed, it will keep running at the same speed.
2. If $T_i \geq 5^\circ\text{C}$ for 2 minutes, MTV2 is turned on. AUX 2 is closed. Indoor fan runs at set speed.

2.E. FAN MODE

1. Indoor fan runs at the set speed while MTV1 and MTV2 is turned off. AUX1 and AUX2 are opened.
2. Indoor fan speed can be adjusted for low, medium, high and auto.

2.F. HEAT MODE

1. If $T_r \leq T_s - 1^\circ\text{C}$, heat operation is activated, MTV1 is turned on. AUX1 is closed. Indoor fan runs at the set speed.
2. If $T_r > T_s$, heat operation is terminated, MTV1 is turned off. AUX1 is opened. Indoor fan runs according to POST HEAT condition. Indoor fan repeatedly runs at low fan speed for 30 seconds and stops for 3 minutes.
3. The range of T_s is 16 to 30 °C.
4. Indoor fan speed can be adjusted for low, medium, high and auto.
5. When turned on, MTV1 requires 30 seconds before it is fully open.
6. When turned off, MTV1 requires 120 seconds before it is fully closed.
7. When the unit is turned off, indoor fan will delay for 5 seconds before it is turned off.

2.F.1. PRE-HEAT

1. If $T_i \leq 32^\circ\text{C}$, when MTV1 is on, AUX1 is closed and indoor fan remains off.
2. If $T_i \geq 38^\circ\text{C}$, when MTV1 is on, AUX1 is closed and Indoor fan runs at set speed.
3. If indoor coil temperature sensor is damaged, pre-heat time is set for 2 minutes and indoor fan runs at set speed.

2.F.2. POST-HEAT

1. If $T_i > 38^\circ\text{C}$, when MTV1 is off, AUX1 is opened and indoor fan continues to run at set speed.
2. If $T_i < 38^\circ\text{C}$, when MTV1 is off, AUX1 is opened. Indoor fan runs 30 seconds and stops 3 minutes repeatedly.
3. If indoor coil temperature sensor is damaged, post-heat time is set for 3 minutes with indoor fan running at set speed.

2.F.3. OVER HEAT PROTECTION OF INDOOR COIL

1. If $T_i \geq 75^\circ\text{C}$, MTV1 is turned off, AUX1 is opened and indoor fan remains on and runs at set speed.
2. If $T_i < 70^\circ\text{C}$, MTV1 is turned on. AUX1 is closed and indoor fan remains on and runs at set speed.
3. If indoor coil temperature sensor is damaged, the protection mode will become obsolete and the unit will work as the Pre-heat and Post-heat set times.

2.G. DEHUMIDIFICATION MODE

1. MTV1 is off.
2. If $T_r \geq 25^\circ\text{C}$, MTV2 will be ON for 3 minutes and OFF for 4 minutes.
3. If $16^\circ\text{C} \leq T_r < 25^\circ\text{C}$, MTV2 will be ON for 3 minutes and OFF for 6 minutes.
4. If $T_r < 16^\circ\text{C}$, MTV2 will be turned off.

2.H. AUTO MODE

1. The cool and heat operation will be selected automatically depending on the T_r and T_s .
2. If auto mode is in cool operation, the operation will only change to heat if $T_r < T_s - 3.5^\circ\text{C}$.
3. If auto mode is in heat operation, the operation will only change to cool if $T_r > T_s + 1.5^\circ\text{C}$.
4. Cool and Heat options working under Auto mode are the same as those working under Non-Auto mode shown as the following figure.

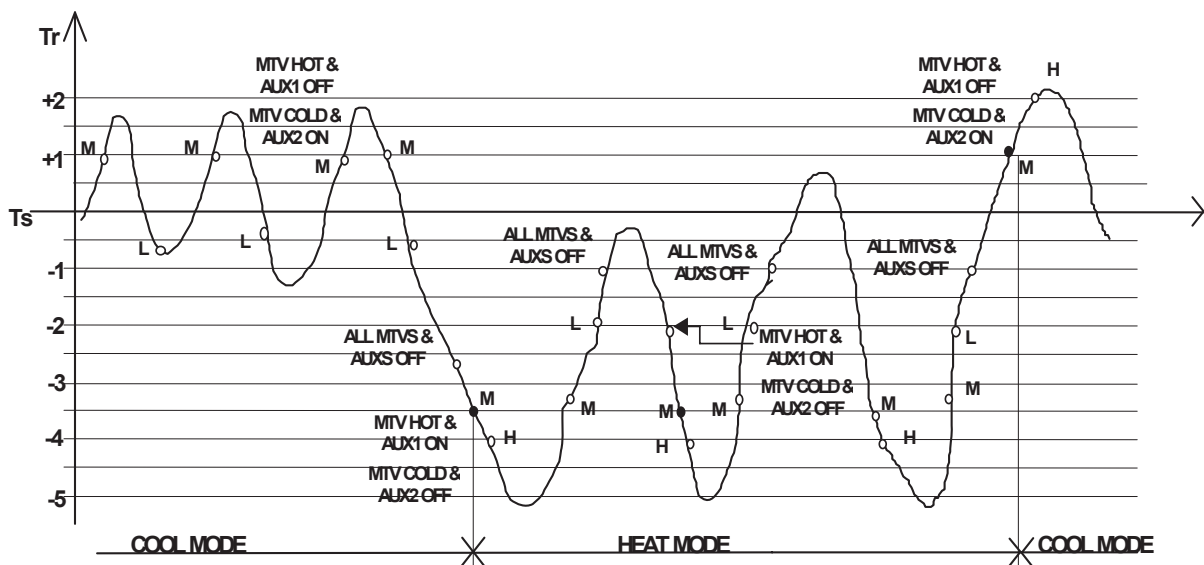

IMPORTANT NOTE: In order to use the auto-mode function, you must have a 4-way valve installed with the unit.

2.I. AUXILIARY CONTACTS

2.I.1. COOL MODE (AUX 2)

1. AUX 2 is closed when MTV2 is on (in normal operation).
2. AUX 2 is opened when MTV2 is off or protection of indoor coil is operating.

2.I.2. FAN MODE (AUX 1 AND AUX 2)

AUX 1 and AUX 2 are opened when indoor fan is on.

2.I.3. HEAT MODE (AUX 1)

1. AUX 1 is closed when MTV1 is on (in normal operation).
2. AUX 1 is opened when MTV1 is off or protection of indoor coil is operating.

2.J. SLEEP MODE

1. Sleep mode can only be set in cool or heat modes.
2. In cool mode, after sleep mode is set, the indoor fan will run at low speed and T_s will increase 2°C during 2 hours.
3. In heat mode, after sleep mode is set, the indoor fan will run at auto fan mode and T_s will decrease 2°C during 2 hours.
4. Changing of operation mode will cancel sleep mode.

The COOL mode SLEEP profile is as follow:

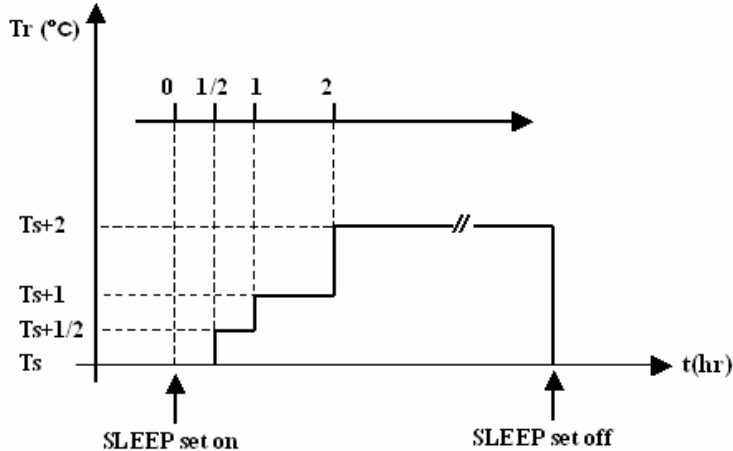

The HEAT mode SLEEP profile is as follows:

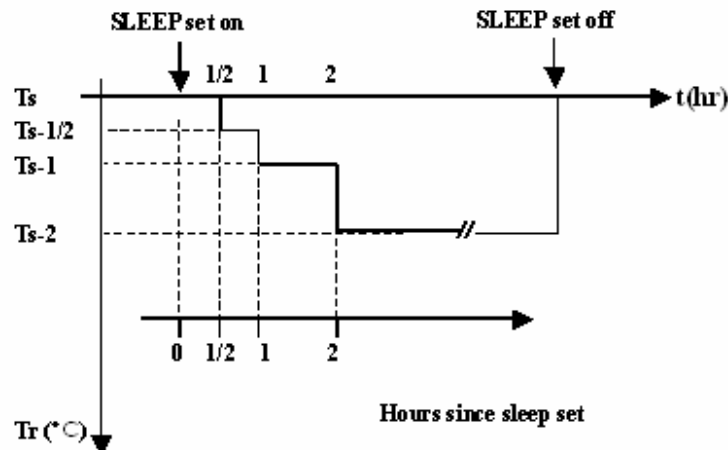

2.K. AUTO FAN SPEED

1. In COOL mode, if $Tr < Ts + 2^{\circ}C$, indoor fan runs at low speed.
 If $Ts + 2^{\circ}C \leq Tr < Ts + 3^{\circ}C$, indoor fan runs at medium speed.
 If $Tr \geq Ts + 3^{\circ}C$, indoor fan runs at high speed.
2. In COOL mode, the fan speed cannot change until it has run at this speed over 30 seconds.

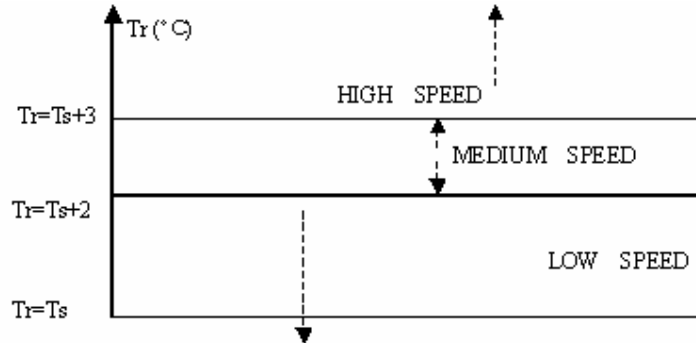

3. In HEAT mode, if $Tr \leq Ts - 1^{\circ}C$, indoor fan runs at low speed.
 If $Ts - 3^{\circ}C \leq Tr < Ts - 1^{\circ}C$, indoor fan runs at medium speed.
 If $Tr < Ts - 3^{\circ}C$, indoor fan runs at high speed.
4. In HEAT mode, the fan speed cannot change until it has run at this speed over 30 seconds.

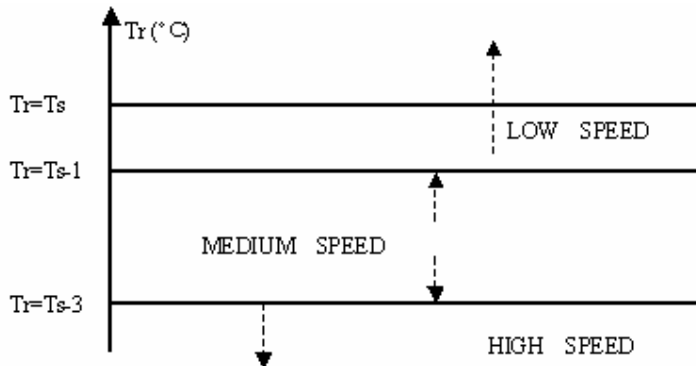

2.L. LOUVER

1. When the unit is connection to power supply, the louver will swing 100 degrees to close condition.
2. When the unit is turned on, the louver will swing 87 degrees from close condition to set mode.
3. When the unit is turned off, the louver will swing 100 degrees back to close condition.
4. At swing mode, louver swings between 59-87 degrees range and can be set within.

2.M. BUZZER

If a command is received by the air conditioner, the system will respond with a beep.

2.N. AUTO RESTART

The system uses non-volatile memory to save the present operation parameters when system is turned off or in case of system failure or cessation of power supply. Operation parameters are mode, set temperature, swing, and the fan speed. When power supply resumes or the system is switched on again, the same operations as previously set will function.

2.O. RESET BUTTON

On the unit front panel next to the LED lights is the reset button. Press it once and unit will operate according to auto mode.

2.P. DRAIN PUMP

2.P.1. THE UNIT IS OFF

If the float switch opens, the drain pump will work. When the float switch closes, the drain pump will run continuously for 5minutes.

2.P.2. THE UNIT IS ON

1. In cool or dehumidify mode, the drain pump will be turned on when valve is on, and will remain on for 5 minutes after the valve is turned off.
2. When the mode is changed, the drain pump will remain on for 5 minutes.
3. If the float switch opens for 5 seconds after the 5minutes has finished, the drain pump is turned on again and the valve closes. After 10 minutes, if the float switch is continually open, the red, yellow and green LEDs will blink to show the drain pump does not work or there is a leak in the system.
4. If the float switch closes, the drain pump will turn off after 5 minutes

3. LED LIGHTS

ITEM	RED LED	YELLOW LED	GREEN LED
High speed	ON	OFF	OFF
Medium speed	OFF	ON	OFF
Low speed	OFF	OFF	ON
Pre-heat	OFF	BLINK	OFF
Post-heat	OFF	OFF	BLINK
Low temperature protection of indoor coil	BLINK	OFF	OFF
Over heat protection of indoor coil	OFF	BLINK	BLINK
Coil temperature sensor damaged	ON	BLINK	BLINK
Room temperature sensor damaged	BLINK	OFF	BLINK
Condensate pump damaged	BLINK	BLINK	BLINK
If the drain pump malfunctions, the red , yellow and green LEDs will blink with beeping sound. Press reset button or any of the remote handset buttons, and the beeping will stop.			

SENSOR RESISTANCE R-T CONVERSION TABLE

R25: 5.00KΩ±1%
B25/85: 3528K±1%

Tx(°C)	Rnom(KΩ)	Tx(°C)	Rnom(KΩ)	Tx(°C)	Rnom(KΩ)
-20	37.4111	16	7.1506	52	1.9007
-19	35.5384	17	6.8652	53	1.8387
-18	33.7705	18	6.5928	54	1.779
-17	32.1009	19	6.3328	55	1.7216
-16	30.5237	20	6.0846	56	1.6663
-15	29.0333	21	5.8475	57	1.6131
-14	27.6246	22	5.621	58	1.5618
-13	26.2927	23	5.4046	59	1.5123
-12	25.033	24	5.1978	60	1.4647
-11	23.8412	25	5	61	1.4188
-10	22.7133	26	4.8109	62	1.3746
-9	21.6465	27	4.63	63	1.3319
-8	20.6345	28	4.4569	64	1.2908
-7	19.6768	29	4.2912	65	1.2511
-6	18.7693	30	4.1327	66	1.2128
-5	17.9092	31	3.9808	67	1.176
-4	17.0937	32	3.8354	68	1.147
-3	16.3203	33	3.6961	69	1.107
-2	15.5866	34	3.5626	70	1.073
-1	14.8903	35	3.4346	71	1.042
0	14.2293	36	3.312	72	1.011
1	13.6017	37	3.1943	73	0.9809
2	13.0055	38	3.0815	74	0.9522
3	12.4391	39	2.9733	75	0.9244
4	11.9008	40	2.8694	76	0.8876
5	11.389	41	2.7697	77	0.8716
6	10.9023	42	2.674	78	0.8466
7	10.4393	43	2.5821	79	0.8223
8	9.9987	44	2.4939	80	0.7989
9	9.5794	45	2.4091		
10	9.1801	46	2.3276		
11	8.7999	47	2.2493		
12	8.4377	48	2.174		
13	8.0925	49	2.1017		
14	7.7635	50	2.032		
15	7.4498	51	1.9651		

CONTROL AND POWER SUPPLY WIRING DIAGRAM

PCE-06/08

- JP0-----Short is master for handset only
- Open is slave for handset and wall pad
- JP1-----Transformer
- JP2-----Power supply
- JP3-----3-way valve for chilled water
- JP4-----Condensate pump
- JP5-----Fan motor
- JP6-----Remote receiver
- JP7-----Stepping motor
- JP8-----Stepping motor
- JP9-----Stepping motor
- JP10-----Stepping motor
- JP11-----Room temperature sensor
- JP13-----Wall pad
- JP14-----Float switch
- JPH-----3-way valve for hot water
- JIPH-----Coil temperature sensor for hot water
- JIPC-----Coil temperature sensor for chilled water
- AUX1-----Auxiliary1
- AUX2-----Auxiliary2

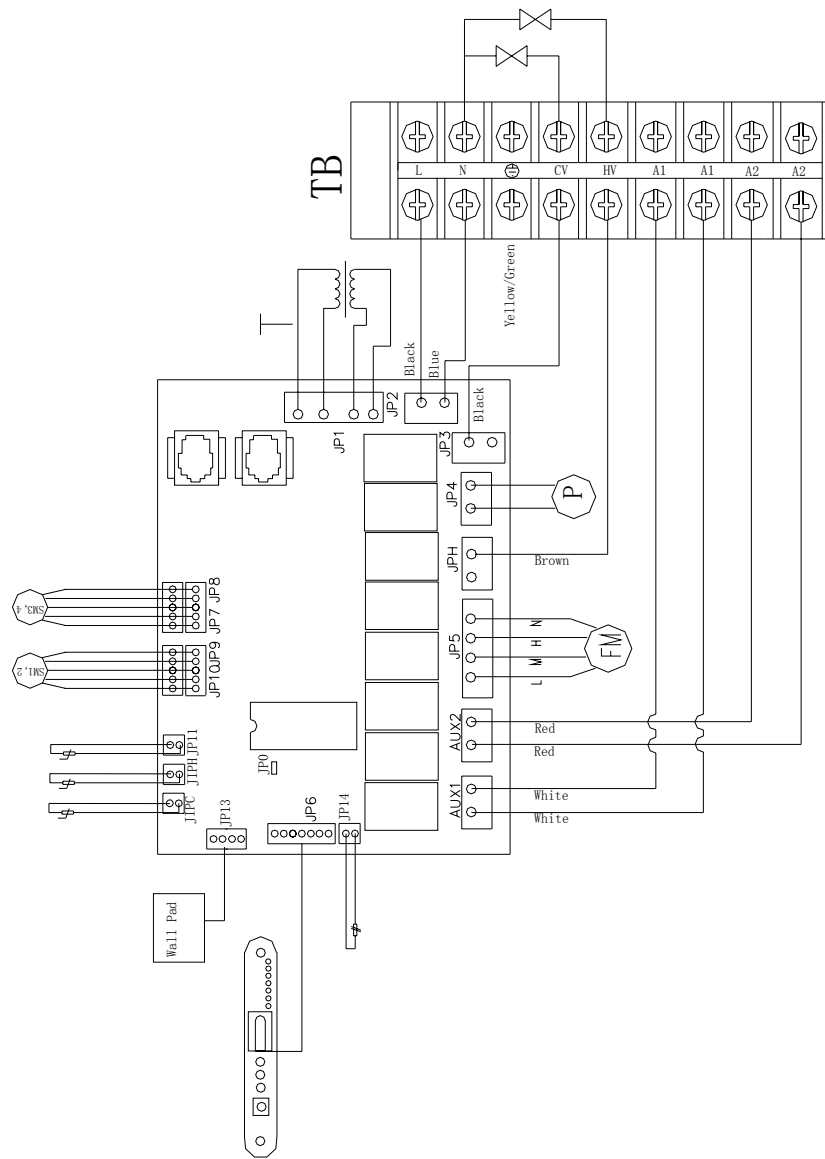

PCE-09/10/12/16

- JP0-----Short is master for handset only
- Open is slave for handset and wall pad
- JP1-----Transformer
- JP2-----Power supply
- JP3-----3-way valve for chilled water
- JP4-----Condensate pump
- JP5-----Fan motor
- JP52-----Fan motor
- JP6-----Remote receiver
- JP7-----Stepping motor
- JP8-----Stepping motor
- JP9-----Stepping motor
- JP10-----Stepping motor
- JP11-----Room temperature sensor
- JP13-----Wall pad
- JP14-----Float switch
- JPH-----3-way valve for hot water
- JIPH-----Coil temperature sensor for hot water
- JIPC-----Coil temperature sensor for chilled water
- AUX1-----Auxiliary1
- AUX2-----Auxiliary2

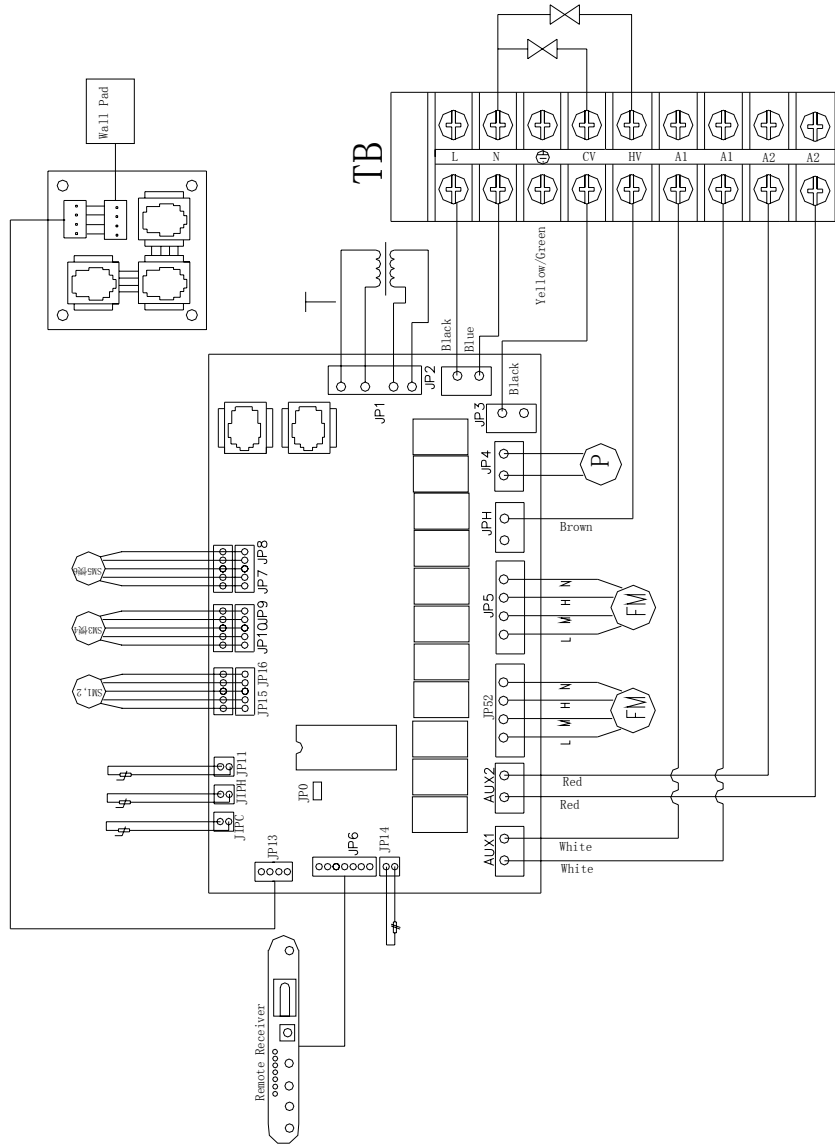

MASTER-SLAVE CONTROL WIRING DIAGRAM

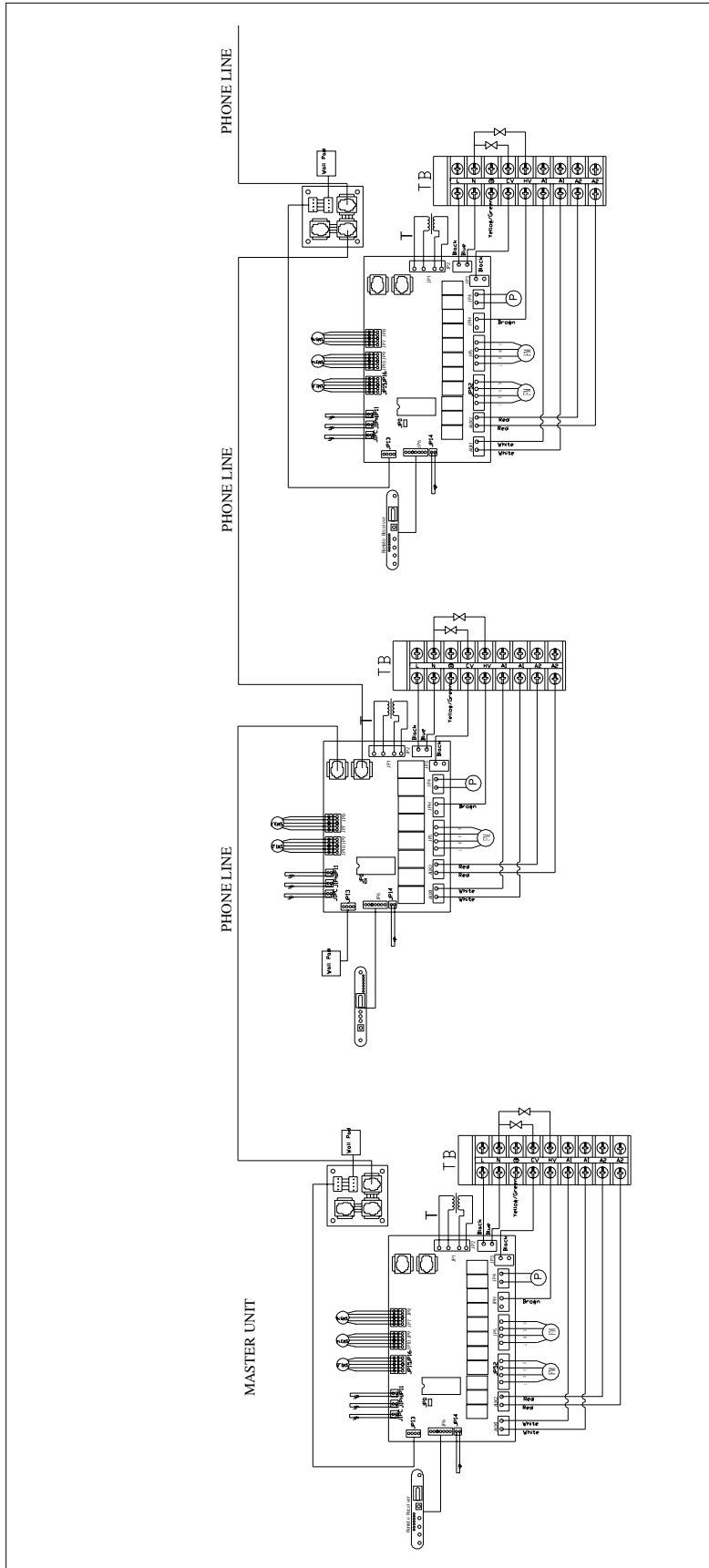

SOLENOID VALVE (OPTIONAL)



The solenoid valve consists of a motor and a main body. The synchronous motor recovers by a spring and can be controlled by a handle. The main body adopts the piston system.

1. TECHNICAL DATA

Power supply:	230VAC50Hz
Input:	5W
Electric machine type:	synchronous
Working pressure:	1.6Mpa
Ambient operating temperature:	0~65 °C
Liquid temperature range:	1~95 °C

2. 3 WAY VALVE

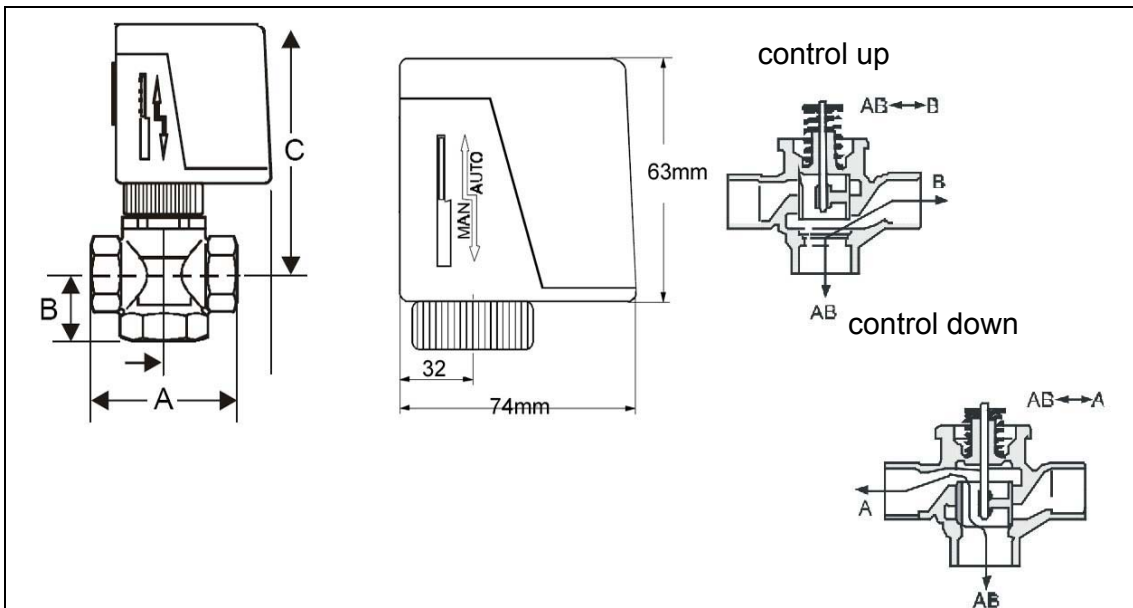

3. SPECIFICATION

ITEM	MODEL	DIAMETER		A	B	C
3 Way valves	VA-7010-8003-15	1/2"	DN15	55	29	98
	VA-7010-8003-20	3/4"	DN20	66	33	37
	VA-7010-8003-25	1"	DN25	98	102	104

Pressure Drop vs. Flow

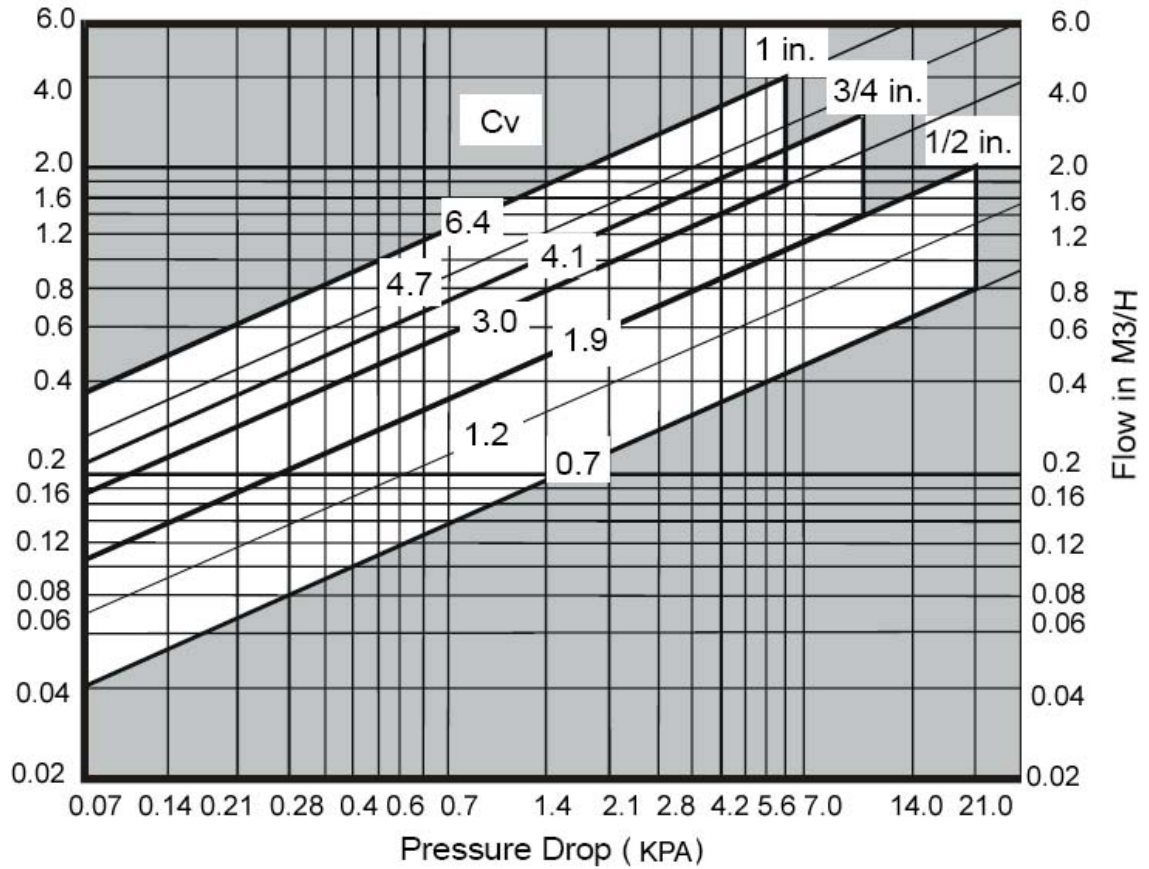

To convert Cv to Kvs, use formula below:
 1 Kvs = 0.86 Cv

4. TERMINAL BLOCK WIRING DIAGRAM

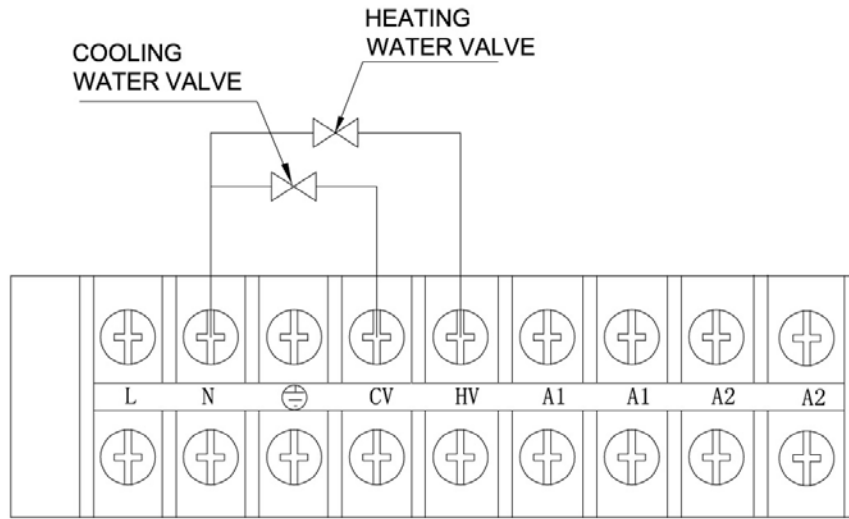

5. WIRING DIAGRAM

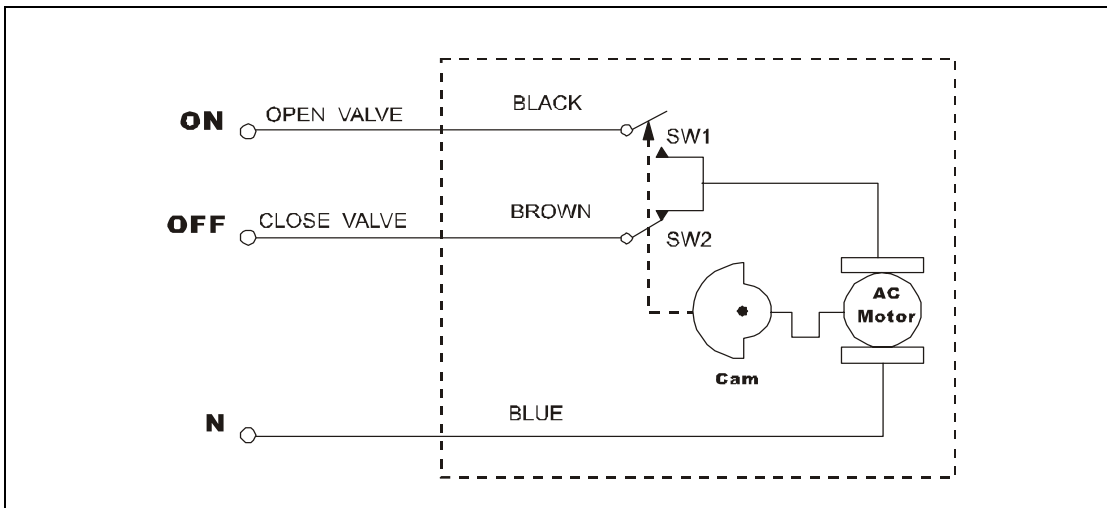

6. INSTALLATION

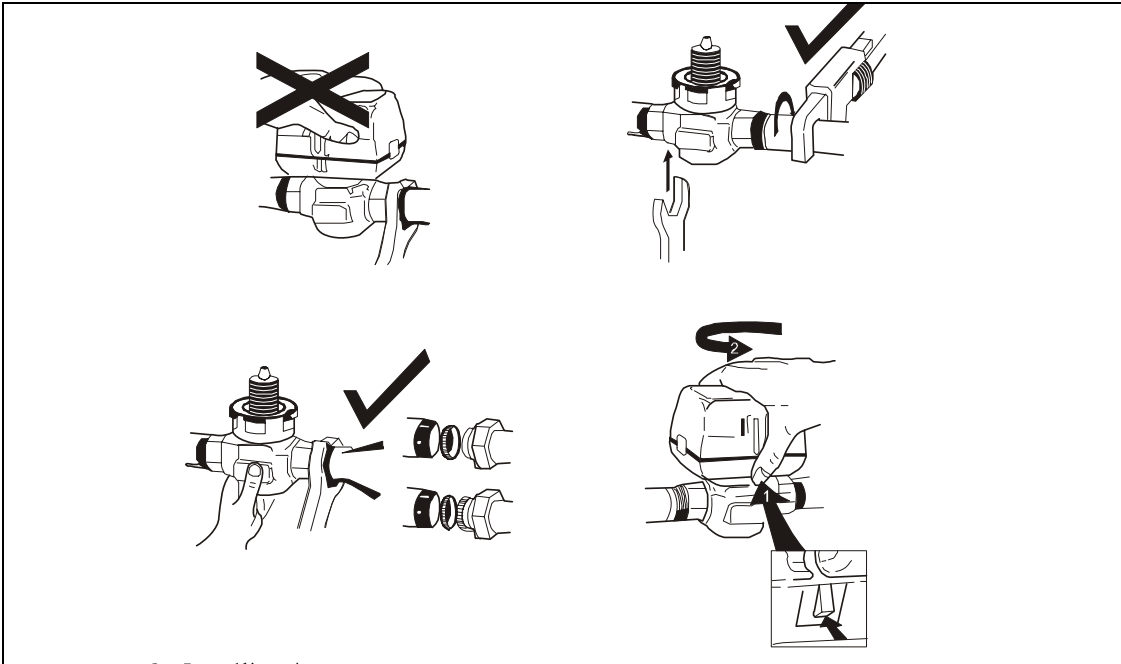

1. Before installation please read the manual carefully.
2. Installation must be carried out by qualified personnel following the instructions in this manual.
3. The motor must be kept on a horizontal level with the main body.

HYDRAULIC CONNECTION DIAGRAM

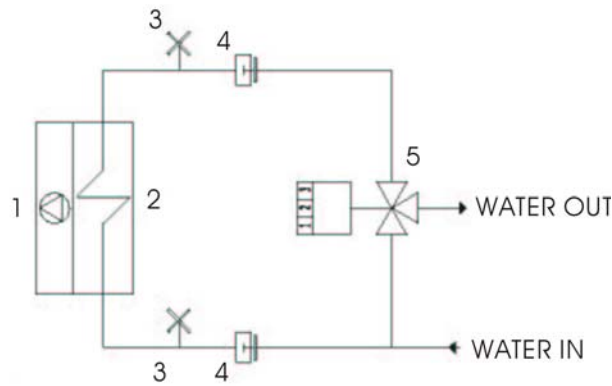

1. Fan 2. Heat exchanger 3. air vent 4. joint 5. solenoid

A SOLENOID VALVE (OPTIONAL) MUST BE FITTED TO CUT OFF WATER FLOW.

The choice and installation of components is the responsibility of the installer who should follow good working practice and legislation in force in the country concerned. Particular types of water used for filling or topping up must be treated with appropriate treatment systems. For references values, see the table.

Reference values	
pH	6 – 8
Electrical conductivity	Less than 200 mV/cm (25°C)
Chlorine ions	Less than 50 ppm
Sulphuric acid ions	Less than 50 ppm
Total iron	Less than 0.3 ppm
Alkalinity M	Less than 50 ppm
Total hardness	Less than 35°f
Sulphur ions	none
Ammonia ions	none
Silicon ions	Less than 300 ppm

TROUBLESHOOTING**ERROR CODE DISPLAY ON WALL PAD DEFINITION TABLE**

CODE NO.	FAILURE SOURCE	ACTION
01	INDOOR ROOM TEMPERATURE SENSOR DAMAGED	REPLACE SENSOR
02	CONDENSED WATER OVER FLOW	DRAIN CONDENSED WATER
03	ROOM TEMPERATURE SENSOR DAMAGED & CONDENSED WATER OVER FLOW	REPLACE SENSOR & DRAIN CONDENSED WATER
04	INDOOR COIL TEMPERATURE SENSOR DAMAGED	REPLACE SENSOR

MALFUNCTION

CAUSE

REMEDY

