

# APPLICATION GUIDE

**INNOV@**

**ENERGY**

Close control units  
eDrive

**6 → 70 kW**



INNOVA ENERGY-AGU-1407-E

[lennoxemeia.com](http://lennoxemeia.com)



# CONTENTS

	<b>PAGE</b>
<b>1. GENERAL DESCRIPTION</b>	<b>3</b>
1.1 Structure	5
1.2 Application limits	6
1.3 Cooling circuit	7
1.4 Installation warnings	10
<b>2. INSPECTION</b>	<b>11</b>
2.1 Inspection on receipt	11
2.2 Lifting and transport	11
2.3 Unpacking	11
2.4 Positioning	11
<b>3. INSTALLATION</b>	<b>12</b>
<b>4. EVACUATION AND CHARGING OPERATIONS</b>	<b>13</b>
4.1 Introduction	13
4.2 Vacuum and charging machine	14
4.3 Evacuating a circuit "contaminated" with refrigerant	14
4.4 Charging positions (single point)	15
<b>5. ELECTRICAL CONNECTIONS</b>	<b>16</b>
5.1 Generalities	16
<b>6. OPERATING DIAGRAMS</b>	<b>17</b>
<b>7. STARTING UP</b>	<b>18</b>
7.1 Preliminary checks	18
7.2 Starting operations	18
7.3 Checks during operations	18
7.4 Checking the refrigerant charge (DX versions)	19
<b>8. SETTING OPERATING PARAMETERS</b>	<b>20</b>
8.1 Generalities	20
8.2 Maximum pressure switch	20
8.3 Minimum pressure switch	20
<b>9. MAINTENANCE</b>	<b>21</b>
9.1 Warnings	21
9.2 Generalities	21
9.3 Inspecting the air filter	22
9.4 Set the right fan speed	25
9.5 Repairing the cooling circuit	25
9.6 Tightness test	26
9.7 Hard vacuum and drying of cooling circuit	26
9.8 Recharging with refrigerant R410C	27
9.9 Environmental protection	27
<b>10. TROUBLESHOOTING</b>	<b>28</b>
<b>11. TECHNICAL DATA</b>	<b>30</b>
<b>12. REFRIGERANT PIPES</b>	<b>32</b>
<b>13. REFRIGERANT CHARGE</b>	<b>32</b>

## Codification

This codification describe the whole **INNOV@** range. All operating modes are not available on each type of unit.

### Type of unit

<b>DM</b>	Medium range height 1875mm
<b>DH</b>	High range height 1998mm
<b>IN</b>	<b>ENERGY</b> range : eDrive unit with EC plug fan and BLDC compressor

### Operating mode

<b>A</b>	:	Direct expansion with remote condenser
<b>W</b>	:	Direct expansion water condensed with remote dry-cooler
<b>Z</b>	:	Direct expansion city water condensed
<b>F</b>	:	Direct expansion water condensed with remote dry-cooler and indirect Free-cooling
<b>C</b>	:	Chilled water unit

### Dual cooling units

In this case this is combination of unit with operating mode above and chilled water to work with chiller. Which provide more safety to your installation.

<b>D</b>	:	Direct expansion with remote condenser +chilled water coil
<b>K</b>	:	Direct expansion water condensed with remote dry-cooler+chilled water coil
<b>Q</b>	:	Direct expansion city water condensed+chilled water coil

### Airflow configuration

<b>U</b>	:	Upflow
<b>D</b>	:	Downflow
<b>X</b>	:	Displacement

### Type of fan

<b>C</b>	:	Centrifugal double inlet forward curve
<b>R</b>	:	EC plug fan

### Nominal capacity

Capacity in kW (in this case 11kW)

# DMAUR0110

### Refrigerant circuit

<b>0</b>	:	1 or No compressor (CW)
<b>2</b>	:	2 compressors / 2 circuits
<b>4</b>	:	4 compressors / 2 circuits
<b>5</b>	:	1 compressor / 1 circuit

# 1. General description

**INNOV@ENERGY** CCAC self-contained units are specially designed for installation in technological environments such as Computer rooms, laboratories and in general where a high precision in climate control and a 24h/day operation are requested. INNOV@ENERGY units represent the state of the art between technology and design as well as all LENNOX products: thanks to their characteristics, INNOV@ENERGY can be installed also in offices where people are working. The depth of 795 mm (600mm for size 091 and size 131) for all versions, allows the compatibility with standard electronic devices: furthermore the innovative design and the high tech selected colours (RAL9002) make INNOV@ENERGY units complementary to the last generation of IT devices. The internal design of the units in firstly made looking to efficiency and reliability but don't losing accessibility: **all** components, including e-heaters, fans, compressors, valves, etc. can be maintained from the front and furthermore the door(s) are dismountable in few seconds thanks to an innovative hinge: this is very important when units are installed in small corridors. The exclusive use of primary brands components and a fully integrated development process (CAD+CAM, CAE) stands for highest possible quality level regarding efficiency, reliability, maintenance time, pre and after sales support. All the units are available both in single circuit up to 34,1 kW and up to 68,5 kW in double circuit.

➤ Single circuit configuration

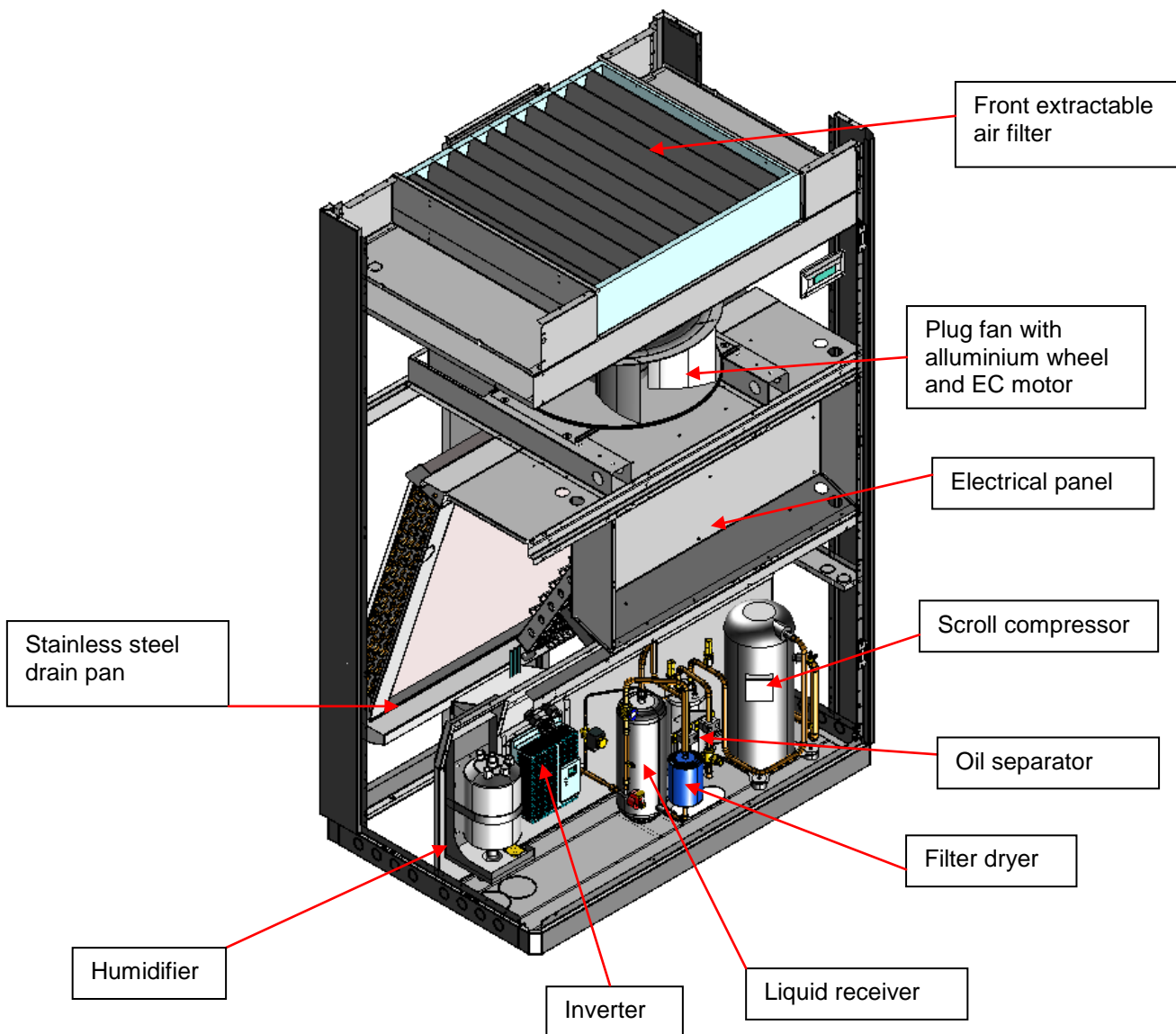

➤ Double circuit configuration

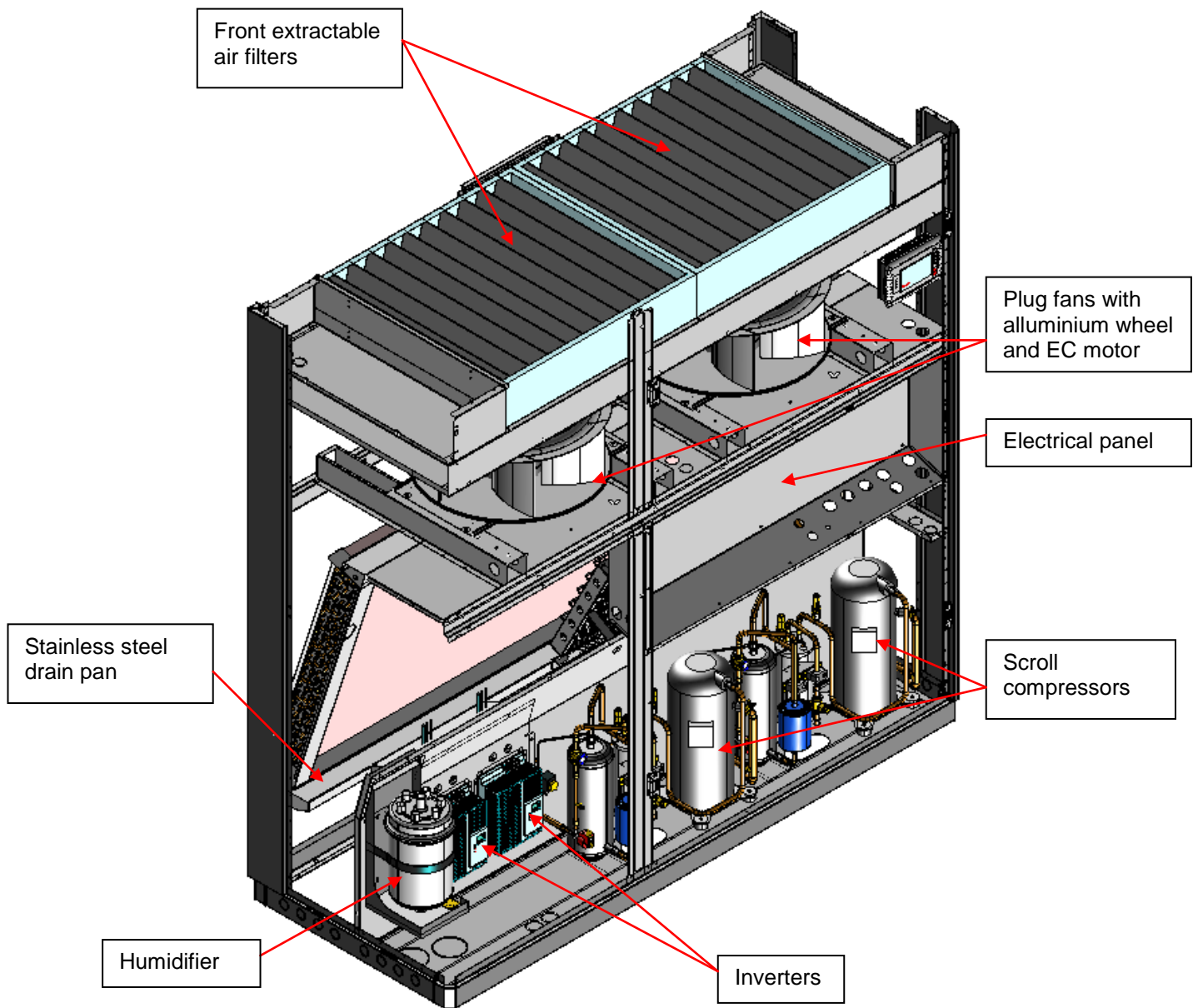

## 1.1 Structure

INNOV@ENERGY units are designed with a self supporting frame and all components are produced using sophisticated computer driven machines and special tools. All sheet metals are galvanized and all external panels are powder coated RAL 9002 giving to the units the image and the quality like last generation of IT devices. Units are completely closed and only frontal access is requested. Anyway it is also possible to have side access in order to reach the steam piping and the drain pan, or simply to substitute a damaged side panel: all this problems are very rare, but with INNOV@ENERGY units it is possible to solve them. The shape of the units is characterized with the curved edges with variable radius as for all LENNOX products: this feature is obtained using special tools and gives both a good aesthetic and advantages against injuries. The compressor compartment is separated from the air flow and the special internal design allows the simple dismounting of the upper part of it ensuring an insuperable accessibility to all refrigerating components. All fixing elements are made in stainless steel or in non corroding materials. The drain pan is made in stainless steel in order to ensure long time operation without damages.

All panels are thermally insulated with a polyurethane foam class 1 according UL 94 norms: this material, thanks to the open cells, gives good performances in sound absorption. As an option, sandwich panels are available: in this case mineral fibres are closed between the panel and a second sheet of metal giving the maximum in terms of internal cleaning. Double skin panels are classified between non flammable materials class A1 according DIN 4102 norms : the sound insulation is better than the standard solution, but the internal reflected sound power will increase the amount in delivery side (+2dB).

### Power supply limits and Storage conditions for DX versions:

Model	INA..R
Power supply	Nominal Value +/-10%
Storage conditions	-10 / 90 % r.h. + 55 / 90 % r.h.

## 1.2 Application limits

- INA..R - Air condensed versions:

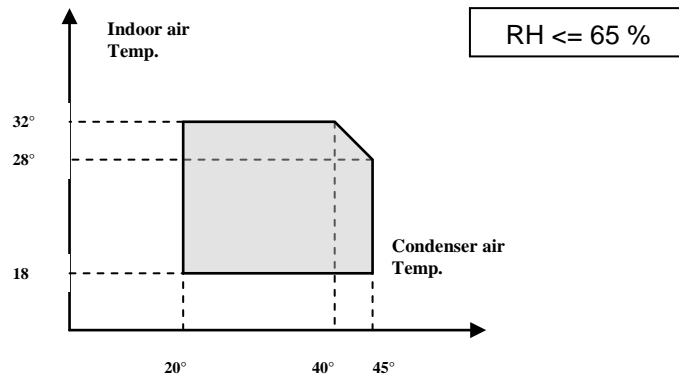

- INW..R - Water condensed versions:

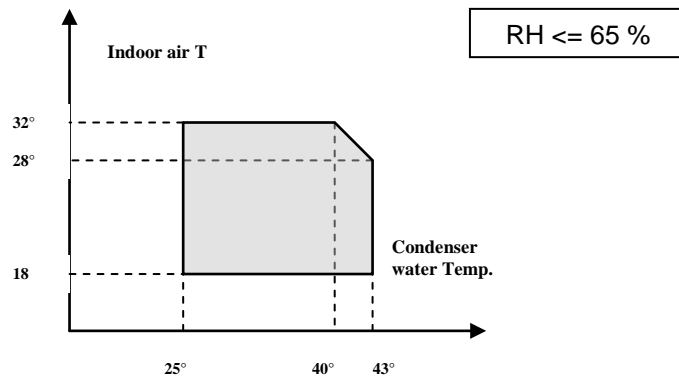



### 1.3 Cooling circuit

The entire refrigerating circuit is assembled in our warehouse including all pipe work and using only primary brand for components. The workers involved in the welding and pipe work process are qualified by a third part according CEE 97/23 PED directive: it is worth to be underlined that this qualification for workers were not request, but it is our own decision taking care of the quality and/or in general to the customer satisfaction. All DX unit ("A", "W", "F", "D", "Q" versions) are precharged with dry nitrogen for "A", "D" or with R410A refrigerant for "W", "F", "Q" versions.

- ❑ **Compressors:** on INNOV@ENERGY units only primary brand scroll compressors in special execution for inverter application motor, are installed (excepted the 060 model in which a rolling piston compressor are installed) . Scroll compressor represent for CCAC units the best solution in terms of efficiency and reliability. The internal compression ratio is very close to the typical operating condition of CCAC giving the maximum in terms of COPs and the perfect balanced pressures at start up gives big advantages to the e\_motor in terms of reliability, mainly in this filed where frequent start up may be possible. All motors are thermally protected with an internal sensors chain: in case of overload this sensor opens without giving contacts to the connection box.
- ❑ **Cooling components:**
  - Molecular mesh activated-alumina filter dryer
  - Flow indicator with humidity indicator. Indications are provided directly on the sight glass.
  - electronic driven valves
  - High and low pressure switches
  - Schrader valves for checks and/or maintenance
- ❑ **Electric control board:** The electric control board is constructed and wired in accordance with Directives 73/23/EEC and 89/336/EEC and related standards. The board may be accessed through a door after the main switch has been turned off. All the remote controls use 24 V signals powered by an insulating transformer situated on the electric control board.  
**NOTE:** the mechanical safety devices such as the high pressure switch are of the kind that trigger directly; their efficiency will not be affected by any faults occurring in the microprocessor control circuit, in compliance with 97/23 PED.
- ❑ **Control microprocessor:** the microprocessor built into the unit allows the different operating parameters to be controlled from a set of pushbuttons situated on the electric control board;
  - Switching on/off of compressor(s) to maintain the temperature set point T inside the shelter
  - Alarm management
    - High / low pressure
    - Dirty filters alarm (optional)
    - Air flow alarm
  - Alarm signalling
  - Display of operating parameters
  - RS232, RS485 serial output management (optional)
  - Phase sequence error [Not displayed by the mP, but prevents the compressor from starting up]

[see microprocessor control manual for further details, also in relation to particular customer specifications]

➤ Basic cooling circuit for DX versions (1 circuit)

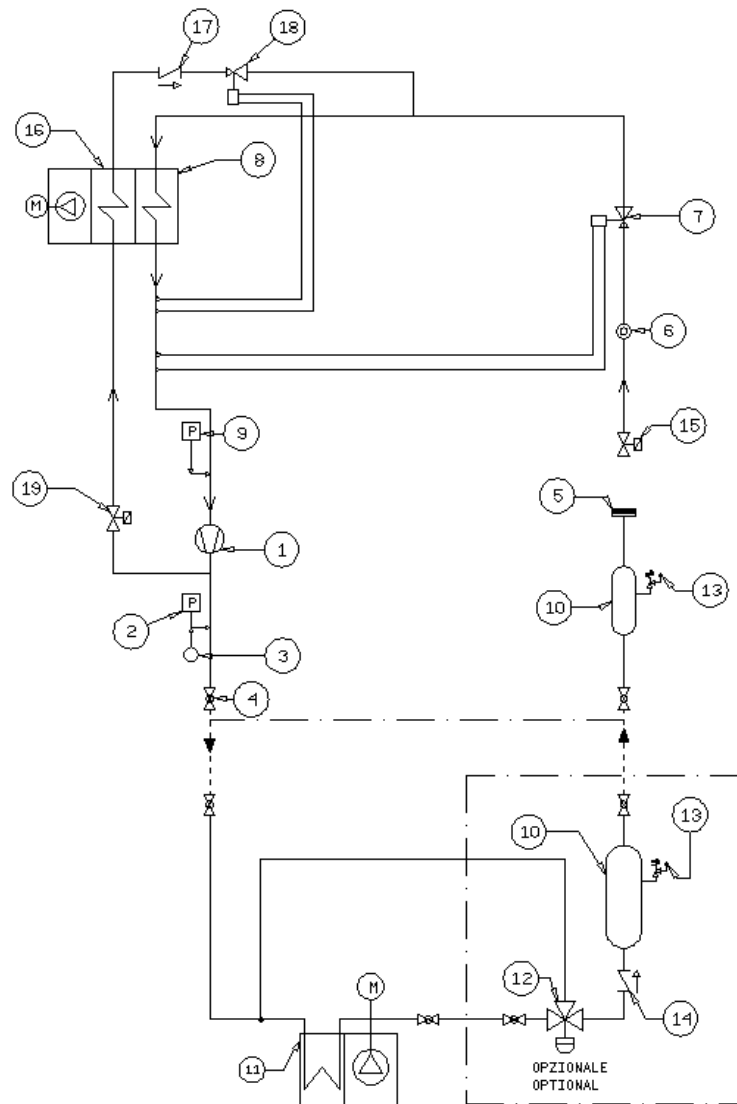

Ref.	Description	Ref.	Description
1	Inverter driver compressor	11	Condenser
2	HP Pressure switch	12	Flooding valve
3	Pressure probe (opt.)	13	Safety valve
4	Ball valve	14	Check valve
5	Refrigerant filter	15	Solenoid valve
6	Sight glass	16	Hot gas coil (opt.)
7	Thermostatic valve	17	Hot gas check valve opt.
8	Evaporator	18	Hot gas thermostatic valve opt.
9	LP pressure switch	19	Hot gas solenoid valve opt.
10	Liquid receiver		

➤ *Basic cooling circuit for DX versions (2 circuits)*

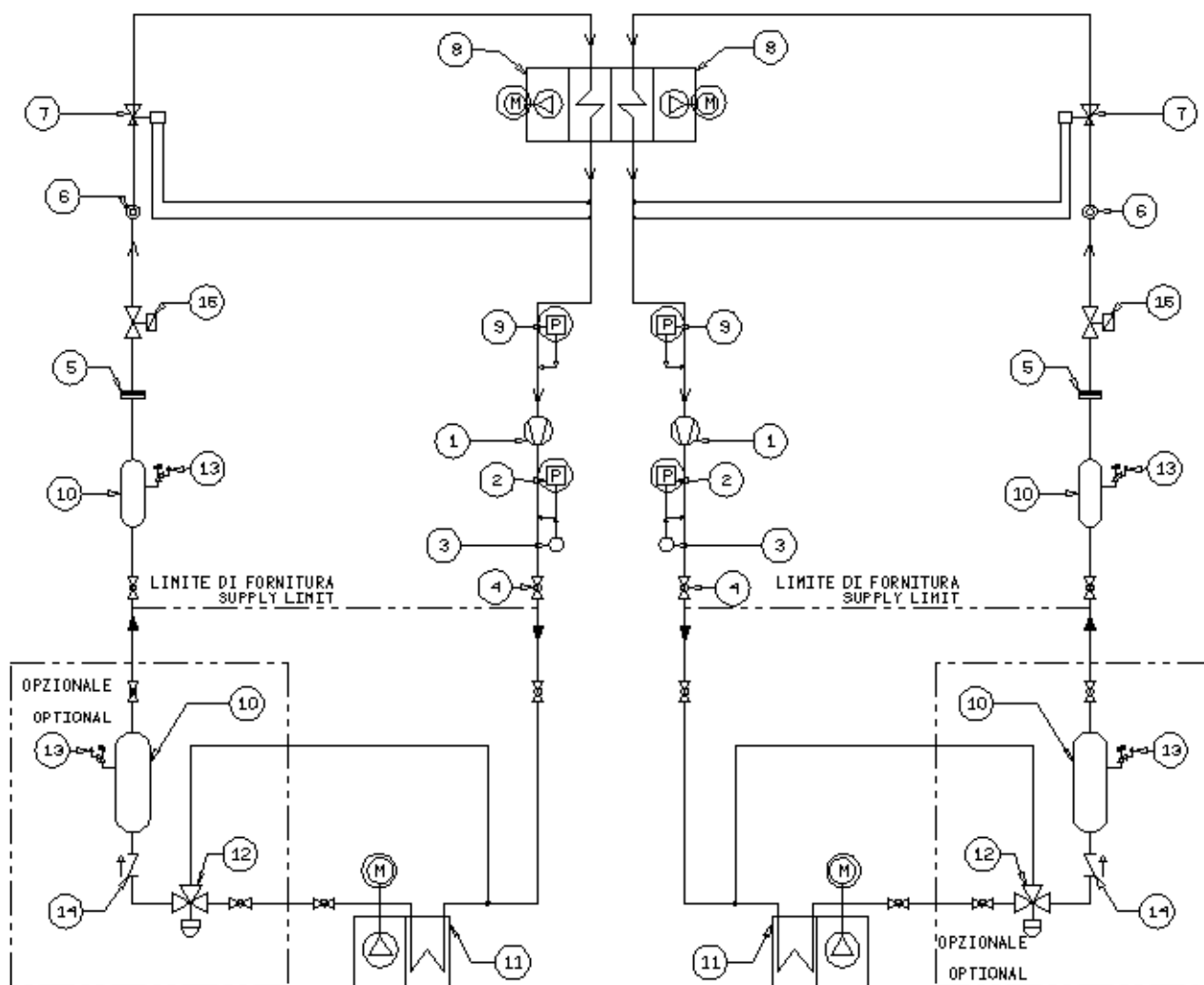

Ref	Description	Ref	Description
1	Inverter driver compressor	9	LP pressure switch
2	HP Pressure switch	10	Liquid receiver
3	Pressure probe (opt.)	11	Condenser
4	Ball valve	12	Flooding valve
5	Refrigerant filter	13	Safety valve
6	Sight glass	14	Check valve
7	Thermostatic valve	15	Solenoid valve
8	Evaporator		

## 1.4 Installation warnings

➤ General rules

- When installing or servicing the unit, you must strictly follow the rules provided in this manual, comply with the directions on the units themselves and take all such precautions as are necessary.
- The fluids under pressure in the cooling circuit and the presence of electrical components may cause hazardous situations during installation and maintenance work.



**All work on the unit must be carried out by qualified personnel only, trained to do their job in accordance with current laws and regulations.**

- Failure to comply with the rules provided in this manual or any modification made to the unit without prior authorisation will result in the immediate invalidation of the warranty.



**Warning: Before performing any kind of work on the unit, make sure it has been disconnected from the power supply.**

## 2. Inspection / Transport / Positioning

### 2.1 Inspection on receipt

On receiving the unit, check that it is perfectly intact: the unit left the factory in perfect conditions; immediately report any signs of damage to the carrier and note them on the Delivery Slip before signing it. LENNOX or its agent must be promptly notified of the entity of the damage. The Customer must submit a written report describing every significant sign of damage.

### 2.2 Lifting and Transport

While the unit is being unloaded and positioned, utmost care must be taken to avoid abrupt or violent manoeuvres. The unit must be handled carefully and gently; avoid using machine components as anchorages or holds and **always keep it in an upright position**. The unit should be lifted using the pallet it is packed on; a transpallet or similar conveyance means should be used.



**Warning: In all lifting operations make sure that the unit is securely anchored in order to prevent accidental falling or overturning.**

### 2.3 Unpacking

The packing must be carefully removed to avoid the risk of damaging the unit. Different packing materials are used: wood, cardboard, nylon etc. It is recommended to keep them separately and deliver them to suitable waste disposal or recycling facilities in order to minimise their environmental impact.

### 2.4 Positioning

Bear in mind the following aspects when choosing the best site for installing the unit and the relative connections:

- positioning and dimensions of the coupling flanges;
- location of power supply;
- solidity of the supporting floor;

It is recommended to first prepare holes in the floor/wall for passing through the power cables and for the air outlet (down flow units).

The dimensions of the air outlet and the positions of the holes for the screw anchors and power cables are shown in the dimensional drawings.

### 3. Installation

The INNOV@ENERGY air-conditioning unit is suitable for all environments except aggressive ones. Do not place any obstacles near the units and make sure that the air flow is not impeded by obstacles and/or situations causing back suction.

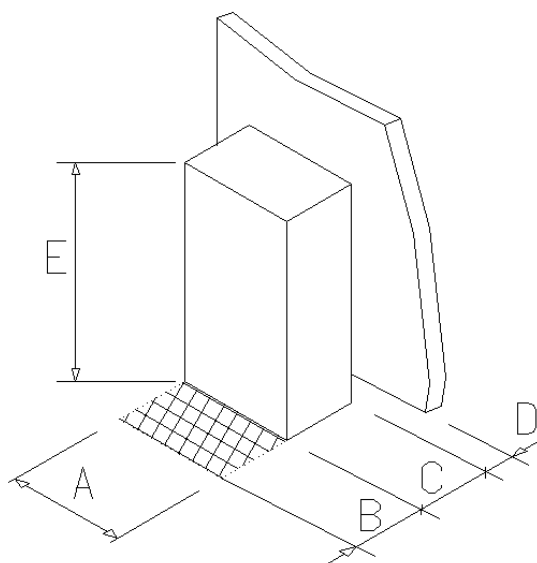

MODEL	A(mm)	B(mm)	C(mm)	D(mm)	E(mm)
INADR0091- INAUR0091	600	650	600	10	1875
INADR0131 - INAUR0131	900	650	600	10	1875
INADR0241 - INAUR0241	1010	750	795	10	1998
INADR0341 - INAUR 0341	1280	750	795	10	1998
INADR0462 - INAUR 0462	2030	750	795	10	1998
INADR0682 - INAUR 0682	2510	750	795	10	1998

The following steps should be carried out to ensure proper installation:

- Apply a anti-vibration rubber lining between the unit and the bottom
- Position the unit on the floor / floorstand (base frame)

The recommended sizes for the power cables and emergency line are shown in the table below:

Model unit	Main power supply	Cable type
INADR0091- INAUR0091	400V/3Ph+N/50Hz	4x2,5 mmq + T 2,5mmq
INADR0131 - INAUR0131		4x6 mmq + T 6mmq
INADR0241 - INAUR0241		4x16 mmq + T 16mmq
INADR0341 - INAUR 0341		4x16 mmq + T 16mmq
INADR0462 - INAUR 0462		4x25 mmq + T 16mmq
INADR0682 - INAUR 0682		4x25 mmq + T 16mmq

## 4. Evacuation and charging operations



This type of work must be carried out by qualified personnel only trained to do their job in accordance with current laws and regulations.

### 4.1 Introductions

The contemporaneous presence of liquid and vapour requires for both to be in a state of saturation [Gibb's law], as shown in the **fig. 1**. In thermal equilibrated conditions, the pressure in the tank corresponds to the ambient temperature. Withdrawal of refrigerant from the tank has following effects:

- withdrawal of refrigerant charge
  - pressure drop inside the tank
  - T drop & change of status
  - cooling of liquid
- ⇒ pressure drop inside the tank
  - ⇒ T drop & change of status
  - ⇒ evaporation of part of the liquid, causing a cooling down of the liquid
  - ⇒ thermal exchange with ambient air, further evaporation of remaining liquid; the original pressure in the tank will be restored after a certain period of time

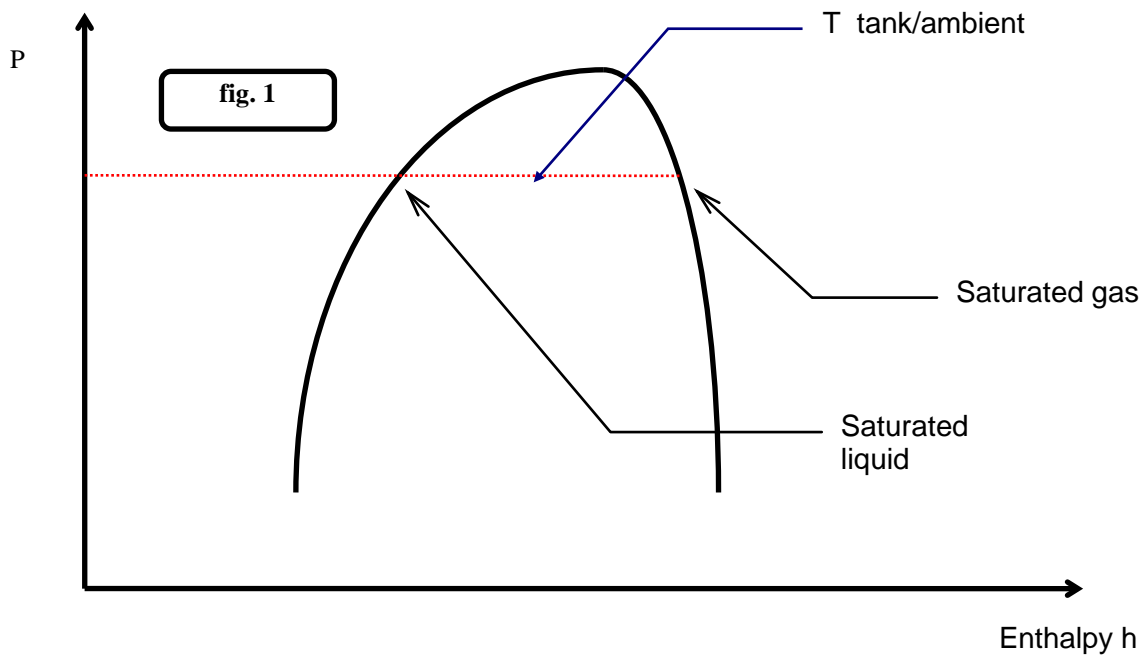

## 4.2 Vacuum and charging machine

### ➤ Vacuum cycle

In general it is better to apply a “long” rather than a “hard” vacuum: reaching a low pressure too abruptly may in fact cause that any remaining humidity evaporates instantaneously, thus freezing part of it.

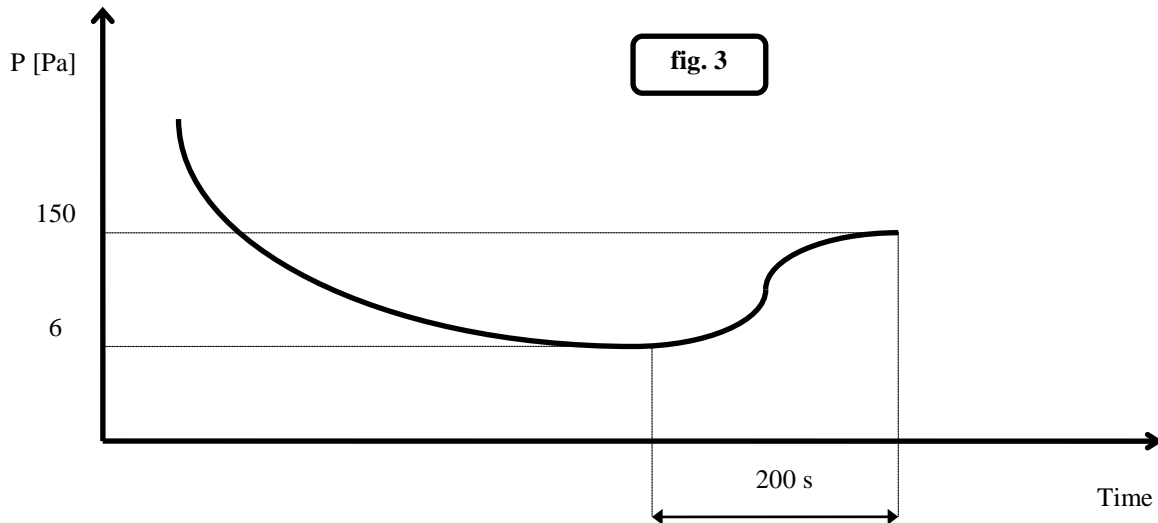

The **fig.3** represents a vacuum cycle and an optimal subsequent pressure rise for the refrigeration devices we manufacture.

Generally in bigger refrigeration systems or if there is a suspicion of an extensive quantity of humidity in the refrigeration circuit, the vacuum needs to be “broken” by using anhydrous nitrogen. Then the steps of evacuation need to be repeated as described before. This operation facilitates the removal of remaining and/or frozen humidity during the evacuation process.

## 4.3 Evacuating a circuit “contaminated” with refrigerant

The first step is to remove the refrigerant from the circuit. To do this a specific machine is necessary with a drying compressor in order to recover the refrigerant.

Refrigerants all tend to dissolve in oil [compressor sump]. The "Oil" figure illustrates a specific property [Charles' Law] of gases, which are more soluble in liquids as the pressure increases but less soluble as the temperature increases.

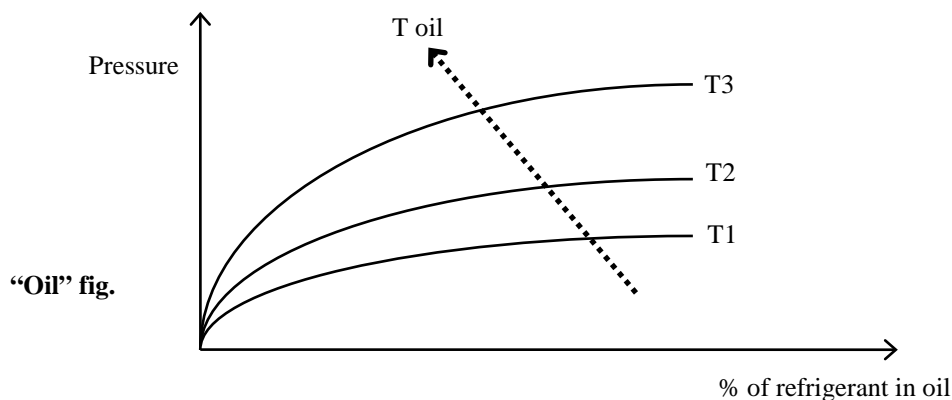

If the oil in the sump is held at a constant pressure, an increase in temperature will significantly reduce the amount of refrigerant dissolved in it, thus ensuring that the lubricating function desired is maintained. The problem of inadequate lubrication occurs if the crankcase is not duly heated, above all after seasonal



interruptions when, due to the suction effect of the compressor, there is an abrupt drop in pressure inside the sump, which results in considerable evaporation of the refrigerant previously dissolved in the oil. If heating elements were not installed, this phenomenon would cause two problems:

The release of refrigerant from the cooling circuit tends to cool down the oil and thus actually creates the opposite effect by keeping more refrigerant dissolved in the oil: for this reason, it is advisable to switch on –if available- the crankcase heater during the evacuation process.

If a high % of refrigerant gets in contact with the Pirani gauge (vacuum sensor), it may “mislead” this sensitive sensor and misinterpret the value for a certain period of time. For this reason -if no machine for recovering refrigerant is available- it is nonetheless advisable to switch on the crankcase heater and to avoid full vacuum before the circuit has been adequately purged of refrigerant. The refrigerant may in fact dissolve in the oil of the vacuum pump, reducing its performance for a long time (hours).

#### **4.4 Charging position (single point)**

The best position to charge the unit is the section between the thermostatic valve and the evaporator. Take care to avoid the fixing of the thermostat bulb until the operation is completed. It is important to ensure that the valve orifice remains open in order to allow the passage of refrigerant also towards the condenser / liquid receiver.

If possible, avoid the charge of refrigerant into the suction line of the compressor as this may cause excessive dilution of the lubricant.

In any case verify first the necessary volume of the crankcase and compare it with the required charge volumes.

## 5. Electrical connections

### 5.1 Generalities



Before carrying out any job on electrical parts, make sure the power supply is disconnected.

Check that the mains electricity supply is compatible with the specifications (voltage, number of phases, frequency) shown on the unit rating plate.

The power connection for single-phase loads is to be made with a three-pole cable and “N” wire at the centre of the star [optional: power supply w/o neutral].



The size of the cable and line protections must conform to the specifications provided in the wiring diagram.

The supply voltage may not undergo fluctuations exceeding  $\pm 5\%$  and the unbalance between phases must always be below 2%.



The above operating conditions must always be complied with: failure to ensure said conditions will result in the immediate invalidation of the warranty.

The electrical connections must be made in accordance with the information shown in the wiring diagram provided with the unit and with current and local regulations.

An earth connection is **mandatory**. The installer must connect the earthing wire using the earthing terminal situated on the electric control board (yellow and green wire).

The power supply to the control circuit is taken from the power line through an insulating transformer situated on the electric control board.

The control circuit is protected by suitable fuses or automatic breakers depending on the unit size.



Never connect the inverter driven compressors directly to the 400/3/50 power supply.

## 6. Operating diagrams

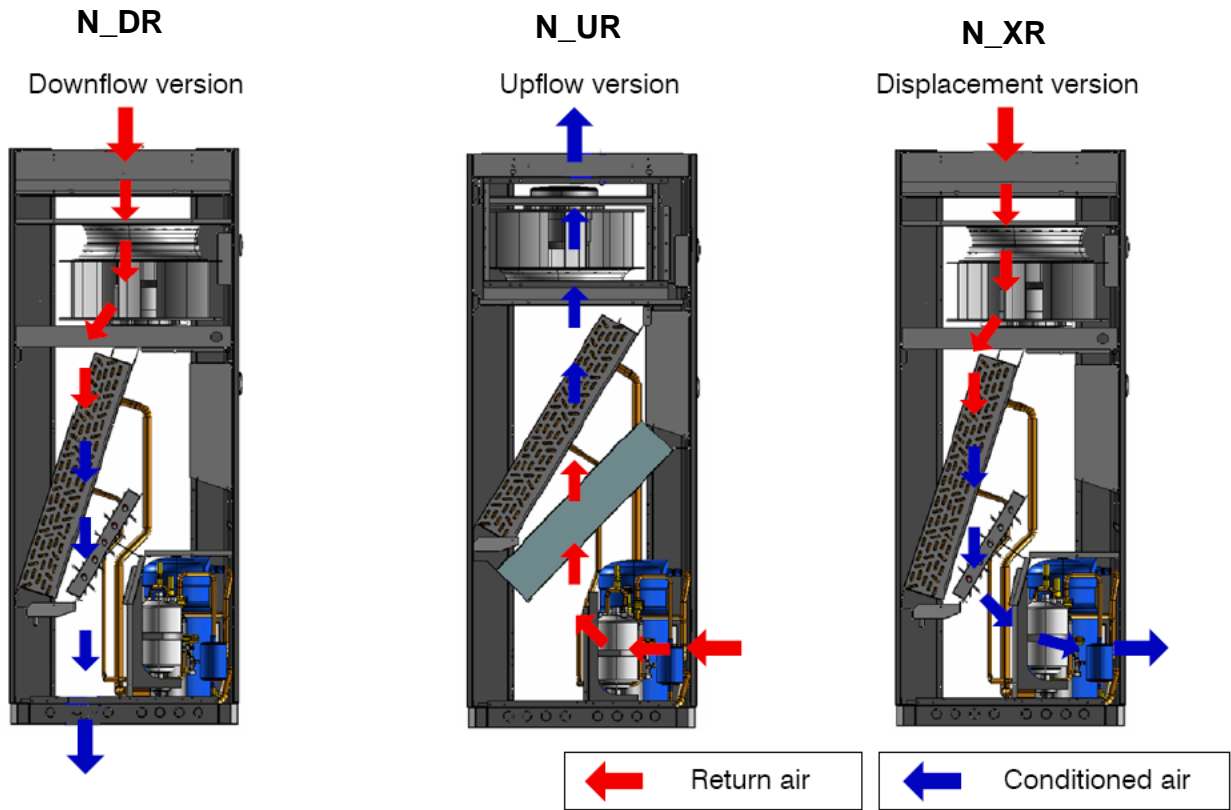

## 7. STARTING UP

### 7.1 Preliminary checks

- Check that the electrical connections have been made properly and that all the terminals **are securely tightened**. This check should also be included in a periodic six-month inspection.
- Check that the voltage at the RST terminals is  $400\text{ V} \pm 5\%$  and **make sure** the yellow indicator light of the phase sequence relay is on. The phase sequence relay is positioned on the electric control board; if the sequence is not duly observed, it will not enable the machine to start.
- Make sure there are no refrigerant leakage that may have been caused by accidental impacts during transport and/or installation.
- Check the power supply to the crankcase heater, where present.



The heating elements must be turned on at least 12 hours before the unit is started. They are automatically activated when the main switch is put on. Their function is to raise the T of the oil in the sump and limit the quantity of refrigerant dissolved in it.

To verify whether the heating elements are working properly, check the lower part of the compressors: it should be warm or in any case at a temperature 10 - 15 °C higher than the ambient temperature.

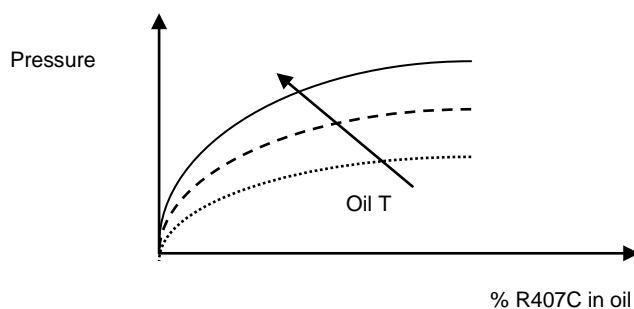

The diagram above illustrates a specific property of gases [Charles' Law], which are more soluble in liquids as the pressure increases but less soluble as the temperature increases: if the oil in the sump is held at a constant pressure, an increase in temperature will significantly reduce the amount of refrigerant dissolved in it, thus ensuring that the desired lubricating function is maintained.

### 7.2 Starting operations

Before starting the unit, turn the main switch on, select the operating mode desired from the control panel and press the "ON" button on the control panel.

If the unit fails to start up, check if the service thermostat has been set according to the nominal values provided.



You should not disconnect the unit from the power supply during periods when it is inoperative but only when it is to be taken out of service for a prolonged period (e.g. at the end of the season).

### 7.3 Checks during operations

- Check the phase sequence relay on the control board to verify whether the phases occur in the correct sequence: if they do not, disconnect the unit from power supply and invert two phases of the incoming three-pole cable. **Never** attempt to modify internal electrical connections: any undue modifications will immediately invalidate the warranty.

## 7.4 Checking the refrigerant charge

- After a few hours of operation, check whether the liquid level indicator has a green ring: a yellow colour indicates the presence of humidity in the circuit. In such a case the circuit must be dehumidified by qualified personnel.
- Large quantities of bubbles should not appear through the liquid level indicator. A constant passage of numerous bubbles may indicate that the refrigerant level is low and needs to be topped up. The presence of a few bubbles is however allowed.
- Make sure that the refrigerant gas super-heating is limited to between 5 and 8 °C: to this end:
  - 1) read the temperature indicated by a contact thermometer placed on the compressor intake pipe;
  - 2) read the temperature indicated on the scale of a pressure gauge likewise connected to the intake side; refer to the pressure gauge scale for the refrigerant R410A.

The degree of super-heating is given by the difference between the temperatures thus determined.
- Make sure that the Sub-cooling of the cooling fluid is limited to between 3 and 5°C: to this end:
  - 1) read the temperature indicated by a contact thermometer placed on the condenser outlet pipe;
  - 2) read the temperature indicated on the scale of a pressure gauge connected to the liquid inlet at the condenser outlet; refer to the pressure gauge scale for the refrigerant R410A.

The degree of Sub-cooling is given by the difference between the temperatures thus determined.



Warning: all the air condensed INNOV@ENERGY units are charged with dry nitrogen. Any top-ups must be made using the same type of refrigerant. This operation is to be considered extraordinary maintenance work and must be performed by qualified personnel only.



Warning: the refrigerant R410A requires "PVE" polyester oil of the type and viscosity indicated on the compressor rating plate.  
For no reason should oil of a different type be introduced into the oil circuit.

### Note :

In INNOV@ENERGY units HFC R410A is used. This refrigerant is a mixture of R32 and R125 (50% - 50%), nearly azeotropic. Its behaviour is much similar to that one of a pure fluid: in fact it introduces a glide approximately 0,1°C.

## 8. Setting operating parameters

### 8.1 Generalities

All the control devices are set and tested in the factory before the unit is dispatched. However, after the unit has been in service for a reasonable period of time you can perform a check on the operating and safety devices. The settings are shown in Table II.



**All servicing of the equipment is to be considered extraordinary maintenance and may be carried out BY QUALIFIED TECHNICIANS ONLY: incorrect settings may cause serious damage to the unit and injuries to persons.**

The operating parameters and control system settings configurable by means of the microprocessor control are password protected if they have a potential impact on the integrity of the unit.

➤ Table II - setting of control devices

CONTROL DEVICE	SET POINT	DIFFERENTIAL
Differential air pressure switch (air flow)..... Pa	50	30
Differential air pressure switch (dirty filter) ..... Pa	70	20

CONTROL DEVICE	ACTIVATION	DIFFERENTIAL	RESETTING
Maximum pressure switch .....Bar-g	42.0	13.0	Manual
Minimum pressure switch .....Bar-g	2	1.3	Automatic
Modulating condensation control devices (DX versions).....Bar-g	14	7	-
Time lapse between two compressor starts ..... s	480	-	-

### 8.2 Maximum pressure switch

The high pressure switch stops the compressor when the outlet pressure exceeds the set value.



**Warning: do not attempt to change the setting of the maximum pressure switch: Should the latter fail to trip in the event of a pressure increase, the pressure relief valve will open.**

The high pressure switch must be **manually** reset; this is possible only when the pressure falls below the differential set (see Table II).

### 8.3 Minimum pressure switch

The low pressure switch stops the compressor when the inlet pressure falls below the set value for more than 180 seconds.

The switch is automatically reset when the pressure rises above the set differential (see Table II).

## 9. Maintenance

The only operations to be performed by the user are to switch the unit on and off. All other operations are to be considered maintenance work and must thus be carried out by qualified personnel trained to do their job in accordance with current laws and regulations.

### 9.1 Warnings



**All the operations described in this chapter MUST ALWAYS BE PERFORMED BY QUALIFIED PERSONNEL ONLY.**



**Before carrying out any work on the unit or accessing internal parts, make sure you have disconnected it from the mains electricity supply.**



**The upper part and the outlet pipe of the compressor reach high temperatures. Be especially careful when working in the surrounding area with the panels off.**



**Be especially careful when working in proximity to finned coils since the 0.11 mm-thick aluminium fins can cause superficial injuries due to cuts.**



**After completing maintenance jobs, always replace the panels enclosing the units and secure them with the fastening screws provided.**

### 9.2 Generalities

To guarantee a constantly satisfactory performance over time, it is advisable to carry out routine maintenance and checks as described below. The indications below are related to standard tear and wear.

Operation	Frequency
• Check the efficiency of all the control and safety devices	Once a year
• Check the terminals on the electric control board and compressor terminal boards to ensure that they are securely tightened. The movable and fixed contacts of the circuit breakers must be periodically cleaned and replaced whenever they show signs of deterioration.	Once a year
• Check the refrigerant level by means of the liquid level indicator	Every 6 months (DX)
• Check the efficiency of the differential air pressure switch and dirty filter differential pressure switch	Every 6 months
• Check the condition of the air filter and replace it if necessary	Every 6 months
• Check the humidity indicator (green=dry, yellow=humid) on the liquid level indicator; if the indicator is not green as shown on the indicator sticker, replace the filter	Every 6 months (DX)

### 9.3 Inspecting the air filter

➤ Inspecting the air filter (MODELS 091-131)

- Open the front panels to access the air filter compartment.
- Pull out the air filter.
- Check the condition of the filter and replace it if necessary

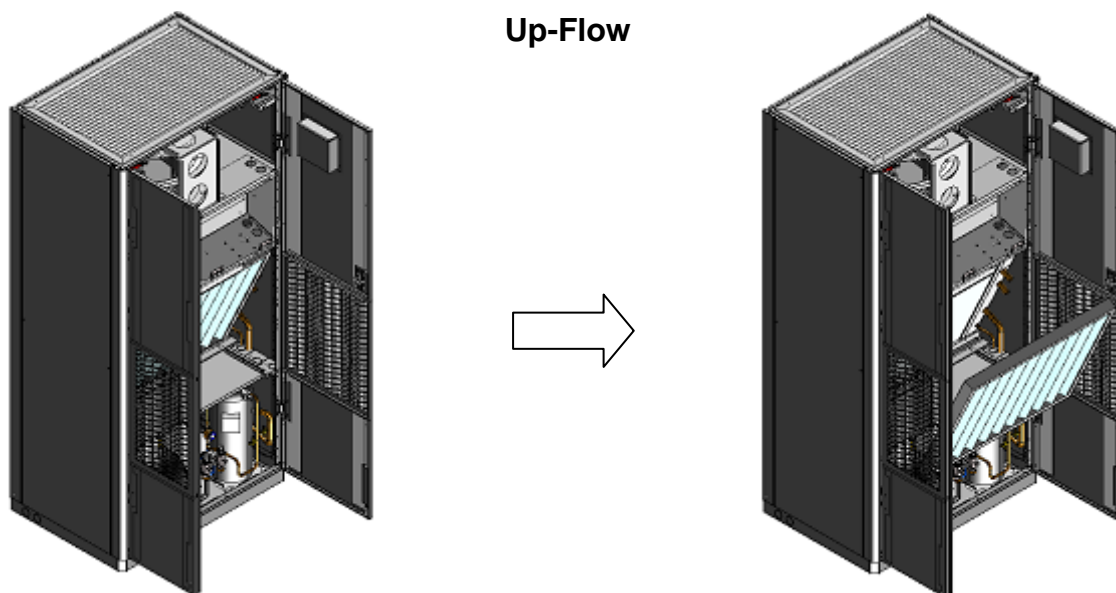
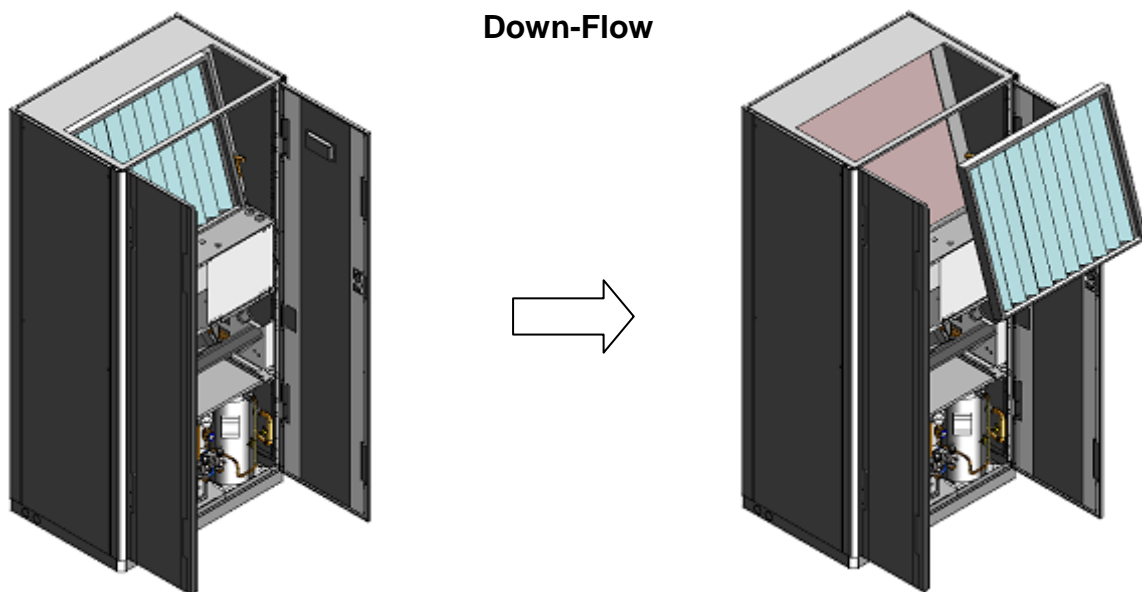



➤ Inspecting the air filter (MODELS 241-341-462-682)

DOWN-FLOW version:

- Open the front panels to access the air filter compartment.
- Pull out the air filter.
- Check the condition of the filter and replace it if necessary

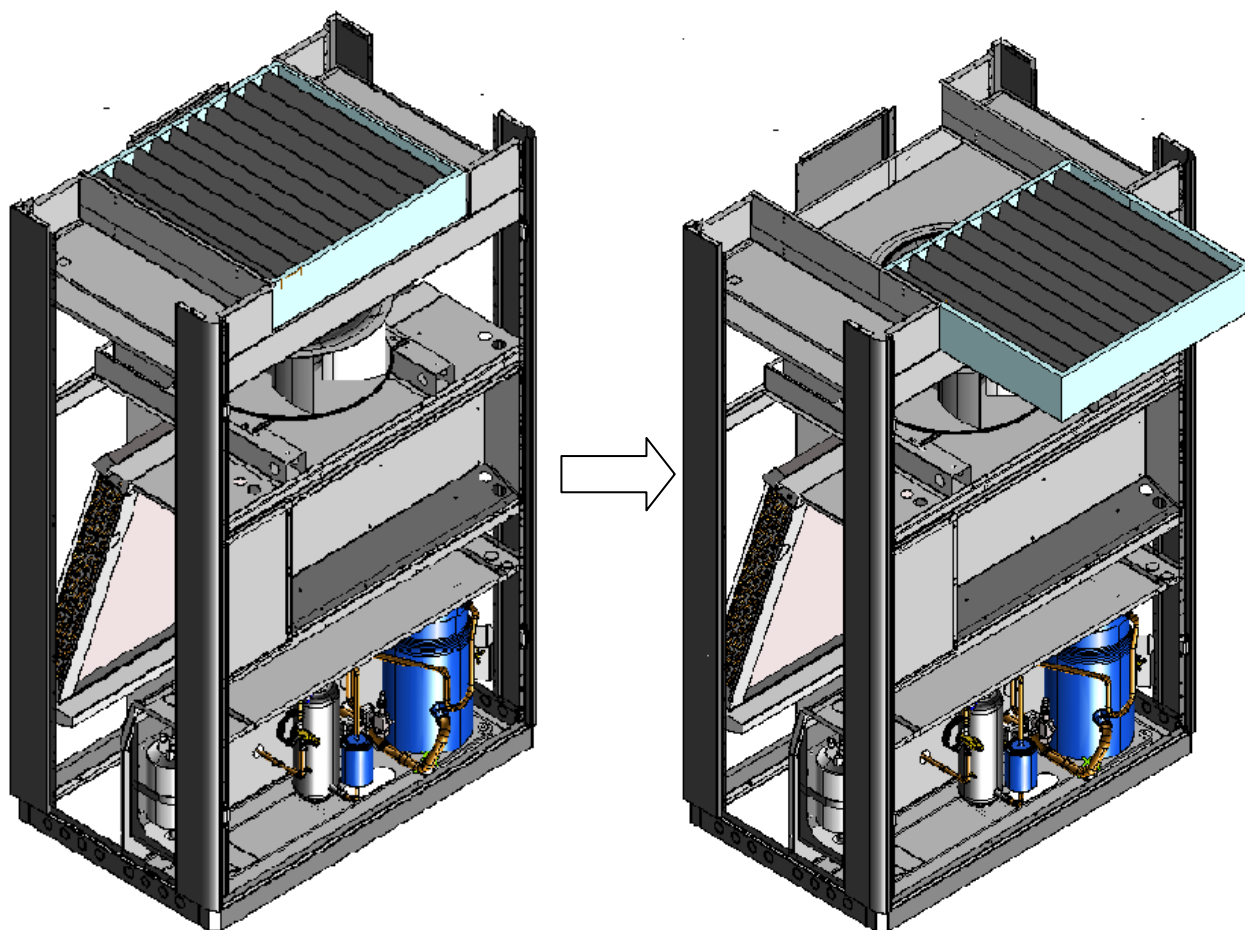

UPFLOW version:

- Open the front panels to access the air filter compartment.
- Remove the screws(\*) and the metallic support [ (\*) no need for tools ]
- Extract the filter on the right.
- Pull on the right side the second filter and then extract it.

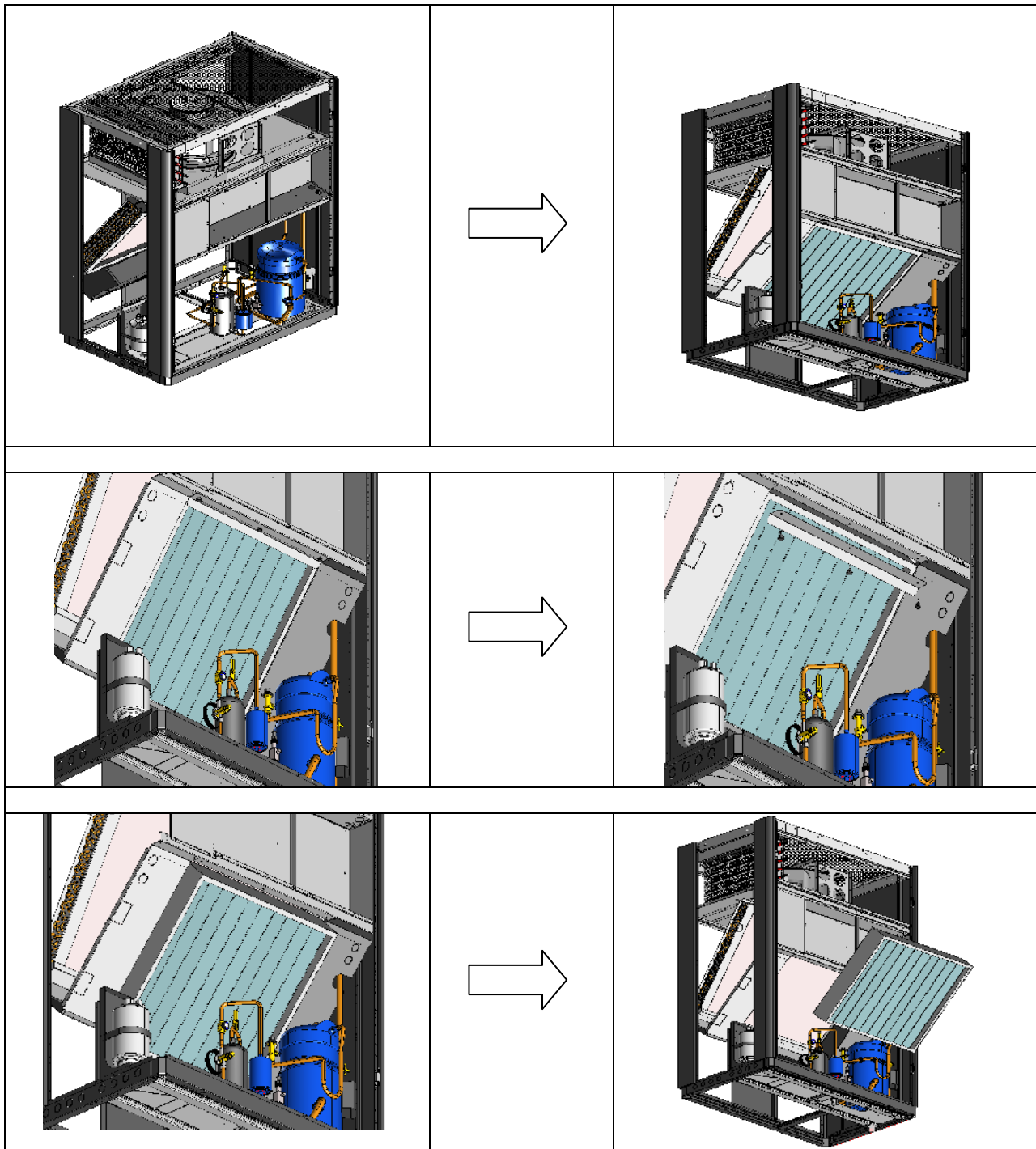

## 9.4 Set the right fan speed

The adopted fans are of the backward curved blades type in combination with EC motor. This kind of fan has very high performances so that its speed has to be reduced in order to match to the nominal air flow with the real external pressure drops: in case of wrong selection, the air flow may exceed the limits with possible water dragging out from the coils (down flow units).

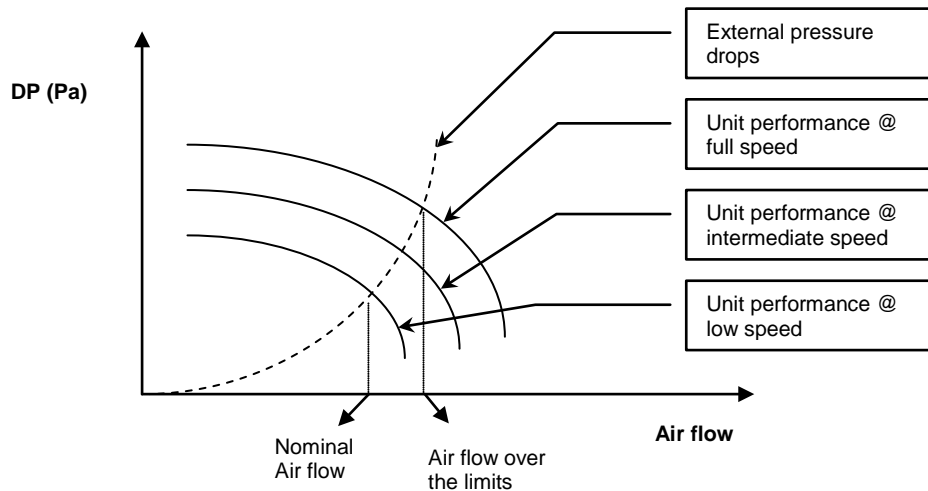

In the EC fans the rotation speeds are selected with different values of the control tension (0 – 10V). The right value of the control tension has to be set by keyboard, considering the AESP requested on site. If the unit is equipped with the “air flow control” option, the mp manage the fan speed in order to obtain the required air flow (Air flow set-point).

## 9.5 Repairing the Cooling Circuit



**Warning:** while performing repairs on the cooling circuit or maintenance work on the compressors, make sure the circuit is left open for as less time as possible. Even if briefly exposed to air, ester oils tend to absorb large amounts of humidity, which results in the formation of weak acids.

If the cooling circuit has undergone any repairs, the following operations must be carried out:

- tightness test;
- evacuation and drying of the cooling circuit;
- charging with refrigerant.



**If the system has to be drained, always recover the refrigerant present in the circuit using suitable equipment; the refrigerant should be handled exclusively in the liquid phase.**

## 9.6 Tightness test

Fill the circuit with anhydrous nitrogen supplied from a tank with a pressure-reducing valve until the pressure rises to 22 bars.



**During the pressurisation phase, do not exceed a pressure of 22 bars on the compressor low pressure side.**

The presence of any leaks must be determined using special leak detectors. Should any leaks be detected during the test, empty out the circuit before repairing the leaks with suitable alloys.



**Do not use oxygen in the place of nitrogen as a test agent, since this would cause a risk of explosion.**

## 9.7 Hard Vacuum and Drying of Cooling Circuit

To achieve a hard vacuum in the cooling circuit it is necessary to use a pump capable of generating a high degree of vacuum, i.e. 150 Pa of absolute pressure with a capacity of approximately 10 m<sup>3</sup>/h. If such a pump is available, one evacuation will normally suffice to achieve an absolute pressure of 150 Pa.

If there is no such vacuum pump available, or whenever the circuit has remained open for long periods of time, you are strongly recommended to adopt the triple evacuation method. This method is also recommended when there is a presence of humidity within the circuit.

The vacuum pump should be connected to the inlets.

The procedure to be carried out is as follows:

- Evacuate the circuit until you reach an absolute pressure of at least 350 Pa: at this point inject nitrogen into the circuit until you reach a relative pressure of about 1 bar.
- Repeat the step described above.
- Carry out the step described above for the third time, but in this case attempting to reach the hardest vacuum possible.

Using this procedure you can easily remove up to 99% of pollutants.

## 9.8 Recharging with refrigerant R410A

- Connect the tank of refrigerant gas to the male 1/4 SAE inlet situated on the liquid line after discharging a little gas to eliminate air in the connection pipe.
- **Fill with refrigerant in liquid form** until you reach 75% of the total charge.
- Then connect to the inlet on the pipe between the thermostatic valve and evaporator and complete the charging process with the refrigerant **in liquid form** until no more bubbles can be seen on the liquid level indicator and the operating parameters specified in this manual have been reached.



**Since R410A is a binary mixture, charging must take place exclusively with liquid refrigerant to ensure the correct percentages of the two constituents. Introduce refrigerant through the inlet in the liquid line.**



**A unit that was originally made to be charged with R410A, must not be charged other refrigerants without the written authorisation of LENNOX.**

## 9.9 Environmental protection

The law implementing the regulations [reg. EEC 2037/00] which govern the use of ozone-depleting substances and greenhouse gases bans the dispersal of refrigerant gases in the environment and requires whoever is in their possession to recover them and, at the end of their useful life, either to return them to the dealer or take them to a suitable waste disposal facility.

The refrigerant HFC R410A is not harmful to the ozone layer but is included among the substances responsible for the greenhouse effect and thus falls within the scope of the aforesaid regulations.



**Therefore, special care should be taken when carrying out maintenance work to minimise refrigerant leaks.**

## 10. Troubleshooting

On the next pages you will find a list of the most common reasons that may cause the package unit to fail or any malfunction. This causes are broken down according to easily identifiable symptoms.



**You should be extremely careful when attempting to implement any of the possible remedies suggested: overconfidence can result in injuries, even serious ones, to inexperienced individuals. Therefore, once the cause has been identified, you are advised to contact the manufacturer or a qualified technician for help.**

FAULT	Possible causes	Corrective actions
<b>The unit does not start.</b>	No power supply.	Check if power is being supplied both to the primary and auxiliary circuits.
	The electronic card is cut off from the power supply.	Check the fuses.
	Alarms have been released.	Check whether any alarms are signalled on the microprocessor control panel, eliminate the causes and restart the unit.
	The phase sequence is wrong.	Invert two phases in the primary power line after disconnecting them upstream from the unit.
<b>The compressor is noisy.</b>	The compressor is rotating in the wrong direction.	Check the phase sequence relay. Invert the phases on the terminal board after disconnecting the unit and contact the manufacturer.
<b>Presence of abnormally high pressure.</b>	Insufficient airflow through the condenser.	Check for the presence of obstructions in the condenser section ventilation circuit.
		Check whether the condenser coil surface is obstructed.
		Check the condensation control device [optional].
	Presence of air in the refrigerant circuit, as revealed by the presence of bubbles in the flow indicator also with sub-cooling values exceeding 5 °C.	Drain and pressurise the circuit and check for leaks. Evacuate slowly [for more than 3 hours] until reaching a pressure of 0.1 Pa and then recharge in the liquid phase.

FAULT	Possible causes	Corrective actions
<b>Presence of abnormally high pressure.</b>	Unit overcharged, as revealed by a Sub-cooling of more than 8 °C.	Drain the circuit.
	Thermostatic valve and/or filter obstructed. These symptoms may also occur in the presence of an abnormally low pressure.	Check the temperatures upstream and downstream from the valve and filter and replace them if necessary.
<b>Low condensation pressure.</b>	Transducer fault.	Check the efficiency of the condensation control device [optional].
<b>Low evaporation pressure.</b>	Malfunctioning of thermostatic valve.	Warming the bulb with your hand, check whether the valve opens and adjust it if necessary. If it does not respond, replace it.
	Filter dryer clogged.	Pressure drops upstream and downstream from the filter should not exceed 2°C. If they do, replace the filter.
	Low condensation T.	Check the efficiency of the condensation control device [where present].
	Low level of refrigerant.	Check the refrigerant level by measuring the degree of Sub-cooling; if it is below 2°C replenish the charge.
	The internal thermal protection device has tripped.	In the case of compressors equipped with a protection module, check the thermal contact. Identify the causes after restarting.
<b>The compressor does not start.</b>	The circuit breakers or line fuses have been tripped by a short circuit.	Pinpoint the cause by measuring the resistance of the individual windings and the insulation from the casing before restoring power.
	One of the high or low pressure switches has tripped.	Check on the microprocessor, eliminate the causes.
	The phases have been inverted in the distribution compartment.	Check the phase sequence relay.
<b>Water out from the unit.</b>	The drain pan hole is closed.	Open the front panels, remove the sheet metal just below the e-panel (Down Flow units) and clean it.
<b>Water out from the unit.</b>	The siphon is missing.	Check for the presence and provide for a new one.
<b>Water out from the unit.</b>	The Air flow is too high.	Reduce the fan speed up to reaching the nominal air flow.

## 11. Technical data

<b>INNOV@ENERGY</b>			<b>0091</b>	<b>0131</b>	<b>0241</b>	<b>0341</b>
Sound pressure level *		dB(A)	44	46	49	51
<b>Compressor</b>						
Type (BLDC)			Twin-Rotary	Twin-Rotary	Scroll	Scroll
Nr of compressors/Nr of circuits			1/1	1/1	1/1	1/1
<b>Max speed compressor</b>	Total capacity	kW	9.3	12.3	24.4	34.4
	Sensible capacity	kW	8.3	11.5	23.2	28.9
	SHR		0.89	0.94	0.95	0.84
	Compressor absorbed power	kW	2.3	3.1	6.7	11.4
	Compressor absorbed current	A	3.7	4.9	10.8	18.3
	EER		4.05	4.03	3.62	3.02
	Fan absorbed power	kW	0.2	0.4	0.9	1.0
	Fan absorbed current	A	0.3	0.6	1.5	1.7
	Nominal airflow rate	m3/h	2150	3700	6800	7280
	Coil air speed	m/s	2.21	2.28	2.78	2.25
Supply temperature	°C	12.6	14.9	14.1	12.4	
<b>Average speed compressor</b>	Total capacity	kW	6.7	8.0	16.2	23.7
	Sensible capacity	kW	6.2	8.0	16.2	21.1
	SHR		0.92	1.00	1.00	0.89
	Compressor absorbed power	kW	1.3	1.5	3.1	5.2
	Compressor absorbed current	A	2.0	2.4	5.0	8.4
	EER		5.36	5.46	5.24	4.55
	Fan absorbed power	kW	0.1	0.2	0.5	0.5
	Fan absorbed current	A	0.1	0.3	0.7	0.8
	Nominal airflow rate	m3/h	1613	2775	5100	5460
	Coil air speed	m/s	1.7	1.7	2.1	1.7
Supply temperature	°C	12.6	15.4	14.6	12.6	
<b>Mini speed compressor</b>	Total capacity	kW	2.9	3.9	5.2	8.0
	Sensible capacity	kW	2.9	3.9	5.2	8.0
	SHR		1.00	1.00	1.00	1.00
	Compressor absorbed power	kW	0.6	0.5	0.8	1.3
	Compressor absorbed current	A	1.0	0.9	1.2	2.0
	EER		4.52	7.23	6.67	6.30
	Fan absorbed power	kW	0.1	0.1	0.2	0.2
	Fan absorbed current	A	0.1	0.1	0.3	0.3
	Nominal airflow rate	m3/h	1075	1850	3400	3640
	Coil air speed	m/s	1.11	1.14	1.39	1.12
Supply temperature	°C	16.0	17.8	19.5	17.5	
Maxi starting current (without option)	A	9.1	16.5	22.4	33.3	
PVE oil load	L	0.35	0.40	1.40	1.40	
<b>Finned coil evaporator</b>						
Number of rows			4	4	5	5
Type of fins		-	Traitement Hydrophile sans silicates			
Fin spacing		Mm	1,8	1,8	2,1	2,1
<b>Indoor fan</b>						
Type			Radial-EC	Radial-EC	Radial-EC	Radial-EC
Electrical supply		V-Ph-Hz	400/3/50	400/3/50	400/3/50	400/3/50
Nr of fans			1	1	1	1
AESP nominal fan speed		Pa	30	30	30	30
AESP maxi fan speed **		Pa	797	709	533	500
<b>Filtration</b>						
Filtration			G3	G3	G3	G3
<b>Electrical heaters</b>						
Total heating capacity		kW	2,5	4,0	6,4	5,6
Material		-	Aluminium	Aluminium	Aluminium	Aluminium
<b>Humidifier</b>						
Maxi capacity		kg/h	3,0	3,0	3,0	3,0
Absorbed power		kW	2,25	2,25	2,25	2,25
<b>Frame</b>						
H		mm	1.875	1.875	1.998	1.998
L		mm	600	900	1.010	1.280
D		mm	449	600	795	795
Weight		kg	157	230	375	605

(\*) At 1,5 meter height, 2 meters frontal distance in free field – down flow units (30Pa AESP), nominal air flow, cp speed 50Hz

(\*\*) Values referred to down flow units (30Pa AESP)

The performances are given considering the units in combination with the suggested remoter condenser and with an outside air T = 35°C.



<b>INNOV@ENERGY</b>			<b>0462</b>	<b>0682</b>	<b>0902</b>	
Sound pressure level *		dB(A)	58	60	58	
<b>Compressor</b>						
Type (BLDC)			Scroll	Scroll	Scroll	
Nr of compressors/Nr of circuits			2/ 2	2/ 2	2/ 2	
<b>Max speed compressor</b>	Total capacity	kW	46.5	68.5	85.9	
	Sensible capacity	kW	46.0	63.7	77.0	
	SHR		0.99	0.93	0.90	
	Compressor absorbed power	kW	13.8	23.5	27.2	
	Compressor absorbed current	A	22.1	37.7	43.6	
	EER		3.37	2.92	3.16	
	Fan absorbed power	kW	2.3	2.6	3.5	
	Fan absorbed current	A	3.8	4.2	5.6	
	Nominal airflow rate	m3/h	14150	19420	22500	
	Vitesse d'air sur l'échangeur	m/s	2.57	2.78	3.22	
Supply temperature	°C	14.6	14.5	14.1		
<b>Average speed compressor</b>	Total capacity	kW	30.8	47.6	63.5	
	Sensible capacity	kW	30.8	47.4	58.4	
	SHR		1.00	1.00	0.92	
	Compressor absorbed power	kW	6.4	10.7	13.5	
	Compressor absorbed current	A	10.2	17.2	21.6	
	EER		4.85	4.43	4.71	
	Fan absorbed power	kW	1.1	1.3	1.7	
	Fan absorbed current	A	1.8	2.0	2.7	
	Nominal airflow rate	m3/h	10613	14565	16875	
	Vitesse d'air sur l'échangeur	m/s	1.9	2.1	2.4	
Supply temperature	°C	15.5	14.4	13.8		
<b>Mini speed compressor</b>	Total capacity	kW	10.0	15.8	30.8	
	Sensible capacity	kW	10.0	15.8	30.8	
	SHR		1.00	1.00	1.00	
	Compressor absorbed power	kW	1.6	2.6	4.4	
	Compressor absorbed current	A	2.6	4.1	7.1	
	EER		6.25	6.18	6.93	
	Fan absorbed power	kW	0.4	0.5	0.6	
	Fan absorbed current	A	0.7	0.8	1.0	
	Nominal airflow rate	m3/h	7075	9710	11250	
	Vitesse d'air sur l'échangeur	m/s	1.28	1.39	1.61	
Supply temperature	°C	19.9	19.2	15.9		
Maxi starting current (without option)	A	41.8	57.2	67.2		
Charge d'huile PVE	L	1.40	1.40	1.40		
<b>Finned coil evaporator</b>						
Number of rows	-	4	4	4		
Type of fins	-	Traitement Hydrophile sans silicates				
Fin spacing	Mm	2,1	2.1	2.1		
<b>Indoor fan</b>						
Type		Radial-EC	Radial-EC	Radial-EC		
Electrical supply	V-Ph-Hz	400/3/50	400/3/50	400/3/50		
Nr of fans		2	3	2		
AESP nominal fan speed	Pa	30	30	30		
AESP maxi fan speed **	Pa	482	526	534		
<b>Filtration</b>						
Filtration		G3	G3	G3		
<b>Electrical heaters</b>						
Total heating capacity	kW	11.2	11.2	11.2		
Material	-	Aluminium	Aluminium	Aluminium		
<b>Humidifier</b>						
Maxi capacity	kg/h	8.0	8.00	8.00		
Absorbed power	kW	6.0	6.00	6.00		
<b>Frame</b>						
H	mm	1998	1998	1998		
L	mm	2030	2510	2510		
D	mm	795	795	950		
Weight	kg	632	979	1013		

(\* ) At 1,5 meter height, 2 meters frontal distance in free field – down flow units (30Pa AESP), nominal air flow, cp speed 50Hz

(\*\* ) Values referred to down flow units (30Pa AESP)

The performances are given considering the units in combination with the suggested remoter condensers and with an outside air T = 35°C.

## 12. Refrigerant pipes

On site piping has to be installed by professional workers using only CUB quality copper pipes. Take care in use of nitrogen during all brazing operations in order to avoid humidity and dirty in pipes.

Refrigerant		R410A	R410A	R410A
ENERGY Model		241-341-462-682	131	091
HP horizontal Gas line	[mm] [Inch]	15,88 5/8	12,70 1/2	9,53 3/8
Hp vertical Gas line	[mm] [Inch]	12,70 1/2	9,53 3/8	7,94 5/16
Liquid line	[mm] [Inch]	12,70 1/2	9,53 3/8	9,53 3/8

Table up to 10 m of pipe length

The declared performances are calculated for a max lines length of 10m, in the next table, the absorbed compressor power and the cooling capacity variation percentage for 20m lines, are showed:

ENERGY Model	241-341-462-682			131			091		
Frequency	30Hz	90Hz	110Hz	30Hz	90Hz	110Hz	30Hz	90Hz	110Hz
Cooling Capacity [%]	-0.43	-1.37	-1.80	-0.10	-1.05	-1.70	-0.10	-1.71	-2.86
Power Consumption [%]	+0.25	+1.59	+2.48	+0.54	+1.27	+1.72	+0.54	+2.35	+3.36

### Standard Copper pipes

Diameter [mm]	Thickness [mm]	Minimum bending radius [mm]	System design pressure PS [bar]	PED Category	Max Copper $\sigma_s$ [N/mm <sup>2</sup> ]	Real copper $\sigma$ [N/mm <sup>2</sup> ]	Safety ratio
10	1	36	42	A3 P3	227	16.8	13.5
12	1	36	42	A3 P3	227	21.0	10.8
16	1	46	42	A3 P3	227	29.4	7.7
18	1	56	42	A3 P3	227	33.6	6.8
22	1,5	67	42	A3 P3	227	26.6	8.5
28	1,5	96	42	A3 P3	227	35.0	6.5
35	1.5	70	42	A3P3	227	44.8	5.0
42	1.5	84	42	A3P3	227	54.6	4.2
54	2.0	108	42	A3P3	227	52.5	4.3

## 13. Refrigerant charge

The following table gives an idea of the total refrigerant charge: this should be used just as first reference but the right charge should be performed on site by a qualified installer .

**Note:** The INNOV@ENERGY units as well as the remote condenser are shipped filled with nitrogen or dry air.

ENERGY Model		241-341-462-682*	131	091
Unit Charge	[kg]	3.080	2.190	1.210
Air Cooled Condenser Charge (standard unit)	[kg]	3.870	1.780	1.490
Air Cooled Condenser Charge (low noise unit)	[kg]	5.350	3.870	1.780
Charge for liquid line	[kg/m]	0.130	0.080	0.070

Note: approximated values ( $\pm 20\%$ ), to be verified on site.

(\*) Values referred to each circuit





lennoxemeia.com

**SALES OFFICES :**

**BELGIUM AND LUXEMBOURG**

☎ + 32 3 633 3045

**FRANCE**

☎ +33 1 64 76 23 23

**GERMANY**

☎ +49 (0) 40 589 6235 0

**ITALY**

☎ + 39 02 495 26 200

**NETHERLANDS**

☎ + 31 332 471 800

**POLAND**

☎ +48 22 58 48 610

**PORTUGAL**

☎ +351 229 066 050

**RUSSIA**

☎ +7 495 626 56 53

**SPAIN**

☎ +34 902 533 920

**UKRAINE**

☎ +38 044 585 59 10

**UNITED KINGDOM AND IRELAND**

☎ +44 1604 669 100

**OTHER COUNTRIES :**

**LENNOX DISTRIBUTION**

☎ +33 4 72 23 20 00



Due to Lennox's ongoing commitment to quality, the specifications, ratings and dimensions are subject to change without notice and without incurring liability. Improper installation, adjustment, alteration, service or maintenance can cause property damage or personal injury. Installation and service must be performed by a qualified installer and servicing agency