



KRAMER ELECTRONICS LTD.

USER MANUAL

MODEL:

VA-50P
Power Supply

P/N: 2900-006012 Rev 4

Contents

1	Introduction	1
2	Getting Started	2
2.1	Achieving the Best Performance	2
3	Overview	3
3.1	Defining the VA-50P	3
4	Connecting the VA-50P	5
5	Technical Specifications	7

Figures

Figure 1:	VA-50P Power Supply	4
Figure 2:	Connecting to the VA-50P	6

1 Introduction

Welcome to Kramer Electronics! Since 1981, Kramer Electronics has been providing a world of unique, creative, and affordable solutions to the vast range of problems that confront the video, audio, presentation, and broadcasting professional on a daily basis. In recent years, we have redesigned and upgraded most of our line, making the best even better!

Our 1,000-plus different models now appear in 11 groups that are clearly defined by function: GROUP 1: Distribution Amplifiers; GROUP 2: Switchers and Matrix Switchers; GROUP 3: Control Systems; GROUP 4: Format/Standards Converters; GROUP 5: Range Extenders and Repeaters; GROUP 6: Specialty AV Products; GROUP 7: Scan Converters and Scalers; GROUP 8: Cables and Connectors; GROUP 9: Room Connectivity; GROUP 10: Accessories and Rack Adapters and GROUP 11: Sierra Products.

Congratulations on purchasing your Kramer **VA-50P** *Power Supply*, which is ideal for the following typical applications:

- Any audio/video system using multiple 12V operated products
- As a battery replacement for field/battery operated equipment

2 Getting Started

We recommend that you:

- Unpack the equipment carefully and save the original box and packaging materials for possible future shipment
- Review the contents of this user manual
 - Use Kramer high performance high resolution cables
 - Use only the power cord that is supplied with this machine



Go to <http://www.kramerelectronics.com> to check for up-to-date user manuals, application programs, and to check if firmware upgrades are available (where appropriate).

2.1 Achieving the Best Performance

To achieve the best performance:

- Use only good quality connection cables to avoid interference, deterioration in signal quality due to poor matching, and elevated noise levels (often associated with low quality cables)
- Avoid interference from neighboring electrical appliances that may adversely influence signal quality
- Position your Kramer **VA-50P** away from moisture, excessive sunlight and dust

3 Overview

The **VA-50P** is a 6-port 12V DC power supply. It replaces up to 6 separate 12 volt adapters for Kramer TOOLS™ and other models that use 12V DC power adapters.

In particular, the **VA-50P**:

- Is an efficient six outlet universal switching power supply that can output 12V DC with up to 500mA per output (but not exceeding 2A total)
- Is designed to operate Kramer products that normally use an external 12V DC power transformer
- Can be secured in a rack using the model RK-50RN kit that holds two **VA-50P** units and requires two vertical spaces in a standard 19" rack
- Can save valuable space on power strips, by replacing up to six wall transformers



Make sure that the polarity of the connected unit matches that of the **VA-50P** – that is, the center pin is the positive terminal.

3.1 Defining the VA-50P

This section defines the **VA-50P**.

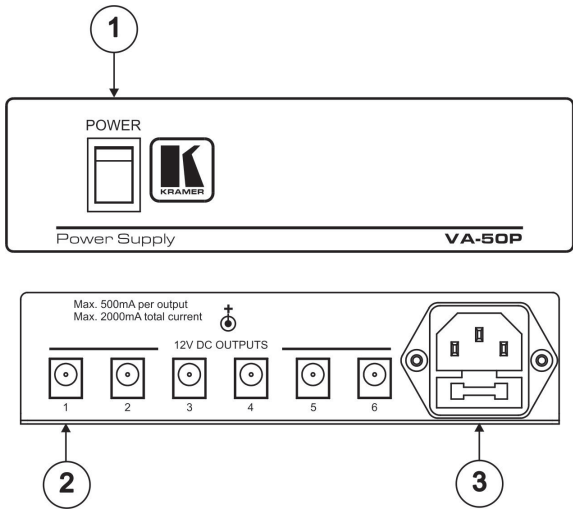

Figure 1: VA-50P Power Supply

#	Feature	Function
1	POWER Switch	Illuminated switch for turning the unit ON or OFF
2	12V DC Power OUTPUTS	Connect to the power inlet on a 12V DC unit (from 1 to 6). Maximum 500mA per output, maximum 2000mA total current
3	Power Connector with FUSE	Socket for connecting the AC power cord to the unit

4 Connecting the VA-50P



Always switch off the power to each device before connecting it to your **VA-50P**. After connecting your **VA-50P**, connect its power and then switch on the power to each device.

To connect the **VA-50P** as illustrated in the example in [Figure 2](#):

1. Connect up to 6 power outlets, using DC-to-DC cables, as follows:
Six DC-to-DC cables are supplied with the VA-50P.
 - Connect the *12V DC OUTPUT 1* power outlet to the *12V DC* power inlet, for example, on a Kramer **FC-14 RGBHV to Component Transcoder**
 - Connect the *12V DC OUTPUT 2* power outlet to the *12DV DC* power inlet, for example, on a Kramer Tools **810 Color Bar / Audio Generator**
 - Connect the *12V DC OUTPUT 3* power outlet to the *12DV DC* power inlet, for example, on a Kramer Pico Tools **PT102VN** unit
 - Connect the *12V DC OUTPUT 4* power outlet to the *12DV DC* power inlet, for example, on a second Kramer Pico Tools **PT102VN** unit
 - Connect the *12V DC OUTPUT 5* power outlet to the *12DV DC* power inlet, for example, on a third Kramer Pico Tools **PT102VN** unit
 - Connect the *12V DC OUTPUT 6* power outlet to the *12DV DC* power inlet, for example, on a Kramer Tools **VP-100** unit
2. Connect the power cord to the mains electricity.

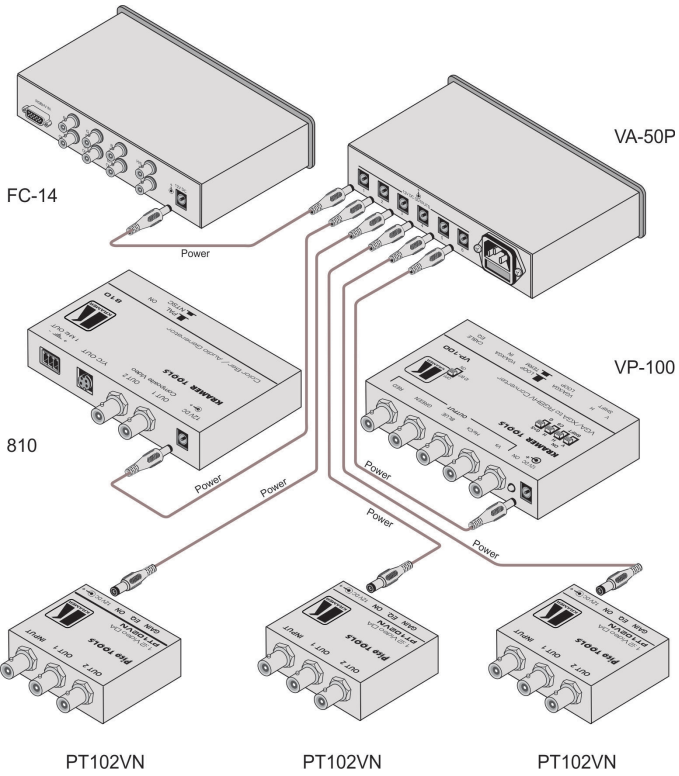

Figure 2: Connecting to the VA-50P

5 Technical Specifications

INPUT POWER SOURCE:	100-240V AC, 50/ 60Hz, Pmax. 42VA.
OUTPUTS:	6 x 12V DC outputs, maximum 500mA per output, maximum 2000mA total current
DIMENSIONS:	16.5cm x 12cm x 4.5cm (6.5" x 4.7" x 1.7") W, D, H
WEIGHT:	1kg (2.2lbs) approx.
ACCESSORIES:	Power cord, vertical stacking bracket, 6 DC-to-DC cables
OPTIONS:	RK-50RN 19" rack adapter
Specifications are subject to change without notice at http://www.kramerelectronics.com	

LIMITED WARRANTY

We warrant this product free from defects in material and workmanship under the following terms.

HOW LONG IS THE WARRANTY

Labor and parts are warranted for seven years from the date of the first customer purchase.

WHO IS PROTECTED?

Only the first purchase customer may enforce this warranty.

WHAT IS COVERED AND WHAT IS NOT COVERED

Except as below, this warranty covers all defects in material or workmanship in this product. The following are not covered by the warranty:

1. Any product which is not distributed by us or which is not purchased from an authorized Kramer dealer. If you are uncertain as to whether a dealer is authorized, please contact Kramer at one of the agents listed in the Web site www.kramerelectronics.com.
2. Any product, on which the serial number has been defaced, modified or removed, or on which the WARRANTY VOID IF TAMPERED sticker has been torn, reattached, removed or otherwise interfered with.
3. Damage, deterioration or malfunction resulting from:
 - i) Accident, misuse, abuse, neglect, fire, water, lightning or other acts of nature
 - ii) Product modification, or failure to follow instructions supplied with the product
 - iii) Repair or attempted repair by anyone not authorized by Kramer
 - iv) Any shipment of the product (claims must be presented to the carrier)
 - v) Removal or installation of the product
 - vi) Any other cause, which does not relate to a product defect
 - vii) Cartons, equipment enclosures, cables or accessories used in conjunction with the product

WHAT WE WILL PAY FOR AND WHAT WE WILL NOT PAY FOR

We will pay labor and material expenses for covered items. We will not pay for the following:

1. Removal or installations charges.
2. Costs of initial technical adjustments (set-up), including adjustment of user controls or programming. These costs are the responsibility of the Kramer dealer from whom the product was purchased.
3. Shipping charges.

HOW YOU CAN GET WARRANTY SERVICE

1. To obtain service on you product, you must take or ship it prepaid to any authorized Kramer service center.
2. Whenever warranty service is required, the original dated invoice (or a copy) must be presented as proof of warranty coverage, and should be included in any shipment of the product. Please also include in any mailing a contact name, company, address, and a description of the problem(s).
3. For the name of the nearest Kramer authorized service center, consult your authorized dealer.

LIMITATION OF IMPLIED WARRANTIES

All implied warranties, including warranties of merchantability and fitness for a particular purpose, are limited in duration to the length of this warranty.

EXCLUSION OF DAMAGES

The liability of Kramer for any effective products is limited to the repair or replacement of the product at our option. Kramer shall not be liable for:

1. Damage to other property caused by defects in this product, damages based upon inconvenience, loss of use of the product, loss of time, commercial loss; or:
2. Any other damages, whether incidental, consequential or otherwise. Some countries may not allow limitations on how long an implied warranty lasts and/or do not allow the exclusion or limitation of incidental or consequential damages, so the above limitations and exclusions may not apply to you.

This warranty gives you specific legal rights, and you may also have other rights, which vary from place to place.

NOTE: All products returned to Kramer for service must have prior approval. This may be obtained from your dealer.

This equipment has been tested to determine compliance with the requirements of:

- EN-50081: "Electromagnetic compatibility (EMC); generic emission standard.
Part 1: Residential, commercial and light industry"
- EN-50082: "Electromagnetic compatibility (EMC) generic immunity standard.
Part 1: Residential, commercial and light industry environment".
- CFR-47: FCC* Rules and Regulations:
Part 15: "Radio frequency devices
Subpart B Unintentional radiators"

CAUTION!

- Servicing the machines can only be done by an authorized Kramer technician. Any user who makes changes or modifications to the unit without the expressed approval of the manufacturer will void user authority to operate the equipment.
- Use the supplied DC power supply to feed power to the machine.
- Please use recommended interconnection cables to connect the machine to other components.
* FCC and CE approved using STP cable (for twisted pair products)



For the latest information on our products and a list of Kramer distributors, visit our Web site where updates to this user manual may be found.

We welcome your questions, comments, and feedback.

Web site: www.kramerelectronics.com

E-mail: info@kramerel.com



SAFETY WARNING

Disconnect the unit from the power supply before opening and servicing



P/N: 2900-006012



Rev: 4