

# USER MANUAL

---

## MODEL 2701/I G.703/G.704 NTU with 10Base-T Ethernet Interface



**PATTON**  
**Electronics Co.**



*An ISO-9001  
Certified Company*

Part# 07M2701/I-D  
Doc# 086091UD  
Revised 11/20/00

SALES OFFICE  
(301) 975-1000  
TECHNICAL SUPPORT  
(301) 975-1007  
<http://www.patton.com>

## 1.0 WARRANTY INFORMATION

**Patton Electronics** warrants all Model 2701/I components to be free from defects, and will—at our option—repair or replace the product should it fail within one year from the first date of shipment.

This warranty is limited to defects in workmanship or materials, and does not cover customer damage, abuse, or unauthorized modification. If this product fails or does not perform as warranted, your sole recourse shall be repair or replacement as described above. Under no condition shall **Patton Electronics** be liable for any damages incurred by the use of this product. These damages include, but are not limited to, the following: lost profits, lost savings and incidental or consequential damages arising from the use of or inability to use this product.

**Patton Electronics** specifically disclaims all other warranties, expressed or implied, and the installation or use of this product shall be deemed an acceptance of these terms by the user.

### 1.1 RADIO AND TV INTERFERENCE

The Model 2701/I generates and uses radio frequency energy, and if not installed and used properly—that is, in strict accordance with the manufacturer's instructions—may cause interference to radio and television reception. The Model 2701/I has been tested and found to comply with the limits for a Class A computing device in accordance with the specifications in Subpart J of Part 15 of FCC rules, which are designed to provide reasonable protection from such interference in a commercial installation. However, there is no guarantee that interference will not occur in a particular installation. If the Model 2701/I does cause interference to radio or television reception, which can be determined by disconnecting the cables, the user is encouraged to try to correct the interference by one or more of the following measures: moving the computing equipment away from the receiver, re-orienting the receiving antenna, and/or plugging the receiving equipment into a different AC outlet (such that the computing equipment and receiver are on different branches).

### 1.2 CE NOTICE

The CE symbol on your Patton Electronics equipment indicates that it is in compliance with the Electromagnetic Compatibility (EMC) directive and the Low Voltage Directive (LVD) of the Union European (EU). A Certificate of Compliance is available by contacting Technical Support.

## 1.3 SERVICE

All warranty and nonwarranty repairs must be returned freight prepaid and insured to Patton Electronics. All returns must have a Return Materials Authorization number on the outside of the shipping container. This number may be obtained from Patton Electronics Technical Support at:

tel: **(301) 975-1007**;  
email: **support@patton.com**; or,  
www: **http://www.patton.com**.

**NOTE:** Packages received without an RMA number will not be accepted.

Patton Electronics' technical staff is also available to answer any questions that might arise concerning the installation or use of your Patton Model 2701/I. Technical Support hours: **8AM to 5PM EST, Monday through Friday.**

**WARNING!**  This device is not intended to be connected to the public telephone network.

## 2.0 GENERAL INFORMATION

Thank you for your purchase of this Patton Electronics product. This product has been thoroughly inspected and tested and is warranted for One Year parts and labor. If any questions or problems arise during installation or use of this product, please do not hesitate to contact Patton Electronics Technical Support at (301) 975-1007.

### 2.1 FEATURES

- Terminates G.703 and G.704, E1/fractional E1 service
- Available in low-cost standalone or rack-mountable versions
- n x 64 kbps data rates to 2.048 Mbps
- 10Base-T Ethernet bridge
- PPP (Point to Point Protocol, RFC 1661) with Bridge Control Protocol (RFC 1638)
- 75-ohm dual coax and 120-ohm twisted-pair G.703 connections
- Local and remote loopback diagnostics
- Internal and G.703 network timing
- CE and BABT approvals
- 90-260VAC & 48VDC power options
- Conforms to ONP requirements CTR 12 and CTR 13 for connection to international Telecom networks

### 2.2 DESCRIPTION

The Model 2701/I receives channelized G.704 (n x 64kbps) or clear channel E1/G.703 (2.048-Mbps) data from the telco's digital data network. The Model 2701/I terminates the G.703 telco interface and converts the data for transmission to a user-oriented 10Base-T (802.3) Ethernet interface.

The Model 2701/I supports an integrated 10Base-T (802.3) Ethernet port with transparent bridging capability for IP, IPX, DECnet, NetBIOS and other layer-3 protocols. The 2701/I attaches to the LAN and intelligently bridges data traffic to the large central site router through the telco's leased line network. The 2701/I supports PPP (RFC 1661) and BCP (RFC 1638).

The Model 2701/I is a 10Base-T bridge that operates over G.703/G.704 lines. It uses MAC learning and forwarding to provide seamless LAN-to-LAN connectivity. As a result, corporate enterprises can connect their servers to a pair of NTUs and automatically forward data packets that are meant for the remote network. Local packets are filtered and passed only to the local LAN.

## 3.0 PPP Operational Background

PPP is a protocol used for multi-plexed transport over a point-to-point link. PPP operates on all full duplex media, and is a symmetric peer-to-peer protocol, which can be broken into three main components: 1. A standard method to encapsulate datagrams over serial links; 2. A Link Control Protocol (LCP) to establish, configure, and test the data-link connection; 3. A family of Network Control Protocols (NCPs) to establish and configure different network layer protocols.

In order to establish communications over a point-to-point link, each end of the PPP link must first announce its capabilities and agree on the parameters of the link's operation. This exchange is facilitated through LCP Configure-Request packets.

Once the link has been established and optional facilities have been negotiated, PPP will attempt to establish a network protocol. PPP will use Network Control Protocol (NCP) to choose and configure one or more network layer protocols. Once each of the network layer protocols have been configured, datagrams from the established network layer protocol can be sent over the link. The link will remain configured for these communications until explicit LCP or NCP packets close the link down, or until some external event occurs.

The PPP Bridging Control Protocol (BCP), defined in RFC 1638, configures and enables/disables the bridge protocol on both ends of the point-to-point link. BCP uses the same packet exchange mechanism as the Link Control Protocol (LCP). BCP is a Network Control Protocol of PPP, bridge packets may not be exchanged until PPP has reached the network layer protocol phase.

### 3.1 APPLICATIONS

In situations where a routed network requires connectivity to a remote Ethernet network, the interface on a router can be configured as a PPP IP Half Bridge. The serial line to the remote bridge functions as a Virtual Ethernet interface, effectively extending the routers serial port connection to the remote network. The bridge device sends bridge packets (BPDU's) to the router's serial interface. The router will receive the layer three address information and will forward these packets based on its IP address.

Figure 1 shows a typical Cisco router with a serial interface configured as a PPP Half Bridge. The router serial interface uses a remote device that supports PPP bridging to function as a node on the remote Ethernet network. The serial interface on the Cisco will have an IP address on the same Ethernet subnet as the bridge.

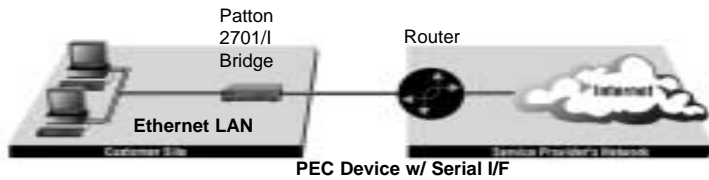

Figure 1. Cisco router with serial interface, configured as PPP Half Bridge.

For example, the customer site is assigned the addresses 192.168.1.0/24 through 192.168.1.1/24. The address 192.168.1.1/24 is also the default gateway for the remote network. The above settings remove any routing/forwarding intelligence from the CPE. The associated Cisco configuration will set serial interface (s0) to accommodate half bridging for the above example.

Authentication is optional under PPP. In a point-to-point leased-line link, incoming customer facilities are usually fixed in nature, therefore authentication is generally not required. If the foreign device requires authentication via PAP or CHAP, the PPP software will respond with default Peer-ID consisting of the units Ethernet MAC address and a password which consists of the unit's Ethernet MAC address.

Some networking systems do not define network numbers in packets sent out over a network. If a packet does not have a specific destination network number, a router will assume that the packet is set up for the local segment and will not forward it to any other sub-network. However, in cases where two devices need to communicate over the wide-area, bridging can be used to transport non-routable protocols.

Figure 2 illustrates transparent bridging between two routers over a serial interface (s0). Bridging will occur between the two Ethernet Interfaces on Router A (e0 and e1) and the two Ethernet Interfaces on Router B (e0 and e1).

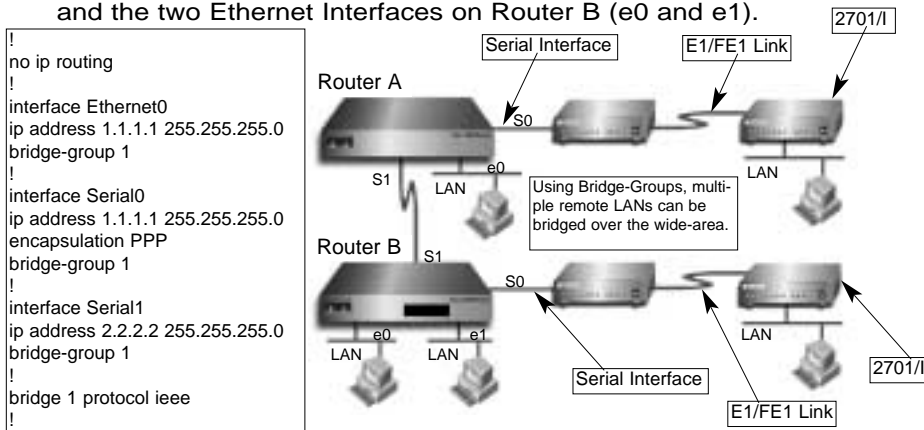

Figure 2. Transparent bridging between two routers over a serial interface.

## 4.0 CONFIGURATION

The Model 2701/I features configuration capability via hardware DIP switches. This section describes all possible DIP switch configurations of the Model 2701/I.

### 4.1 DIP SWITCH CONFIGURATION

The Model 2701/I has two sets of internal DIP switches that allow configuration for a wide range of applications. The sets of switches are accessed from the underside. Figure 3 (below) shows the location of the DIP switches on the bottom of the printed circuit board.

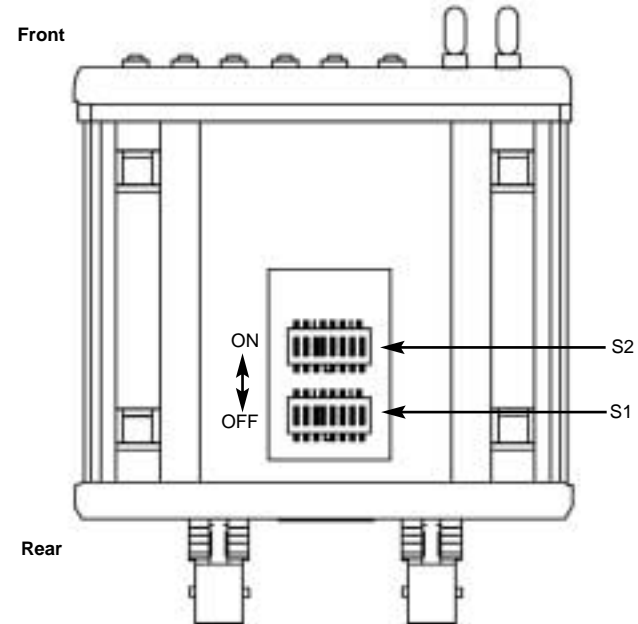

Figure 3. Underside of Model 2701/I, Showing Location of DIP Switches

The Model 2701/I DIP switches (Switch Sets 1-2) can be configured as either "ON" or "OFF". Figure 4 (below) shows the orientation of the DIP switches with respect to ON/OFF positions.

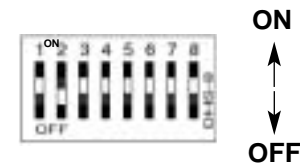

Figure 4. Close up of configuration switches

### Switch SW1-1 through SW1-5

A detailed description of each switch (SW1-1 through SW1-5) setting follows the summary table below.

SWITCH SET 1 SUMMARY TABLE			
Position	Function	Factory Default	Selected Option
SW1-1	DTE Rate	Off	} 2.048 Mbps Clear Channel
SW1-2	DTE Rate	Off	
SW1-3	DTE Rate	Off	
SW1-4	DTE Rate	Off	
SW1-5	DTE Rate	Off	
SW1-6	Clock Mode	Off	Receive Recovered
SW1-7	Clock Mode	Off	Receive Recovered
SW1-8	Not Used	N/A	N/A

Use Switches SW1-5 to set the DTE data rate.

SW1	SW2	SW3	SW4	SW5	Speed
ON	ON	ON	ON	ON	64kbps
OFF	ON	ON	ON	ON	128kbps
ON	OFF	ON	ON	ON	192kbps
OFF	OFF	ON	ON	ON	256kbps
ON	ON	OFF	ON	ON	320kbps
OFF	ON	OFF	ON	ON	384kbps
ON	OFF	OFF	ON	ON	448kbps
OFF	OFF	OFF	ON	ON	512kbps
ON	ON	ON	OFF	ON	576kbps
OFF	ON	ON	OFF	ON	640kbps
ON	OFF	ON	OFF	ON	704kbps
OFF	OFF	ON	OFF	ON	768kbps
ON	ON	OFF	OFF	ON	832kbps
OFF	ON	OFF	OFF	ON	896kbps
ON	OFF	OFF	OFF	ON	960kbps
OFF	OFF	OFF	OFF	ON	1024kbps
ON	ON	ON	ON	OFF	1088kbps
OFF	ON	ON	ON	OFF	1152kbps
ON	OFF	ON	ON	OFF	1216kbps
OFF	OFF	ON	ON	OFF	1280kbps
ON	ON	OFF	ON	OFF	1344kbps
OFF	ON	OFF	ON	OFF	1408kbps
ON	OFF	OFF	ON	OFF	1472kbps
OFF	OFF	OFF	ON	OFF	1536kbps
ON	ON	ON	OFF	OFF	1600kbps
OFF	ON	ON	OFF	OFF	1664kbps

ON	OFF	ON	OFF	OFF	1728kbps
OFF	OFF	ON	OFF	OFF	1792kbps
ON	ON	OFF	OFF	OFF	1856kbps
OFF	ON	OFF	OFF	OFF	1920kbps
ON	OFF	OFF	OFF	OFF	1984kbps
OFF	OFF	OFF	OFF	OFF	Clear Channel 2048kbps

**NOTE:** When the data rate is set to 2.048Mb/s, then the unit is forced into G.703 mode, and it transmits user data on all 32 time-slots. There is no framing information; therefore, the CRC4 MF (SW2-2) switch is ignored. In all other rate settings, the unit employs G.704 framing; TS0 is reserved for signaling.

SW1-6	SW1-7	Clock Mode
On	On	Network (Recieved Recovered)
On	Off	Internal
Off	On	Internal
Off	Off	Network (Recieved Recovered)

### SW1-6 and SW1-7 CLOCK MODES

**Network Clock** Transmitter timing is derived using the received line signal (received recovered) from the network.

**Internal Clock** Transmitter timing is derived from an internal clock source.

SWITCH SET 2 SUMMARY TABLE			
Position	Function	Factory Default	Selected Option
SW2-1	Line Coding	OFF	HDB3
SW2-2	CRC-4 multiframe	OFF	Disabled
SW2-3	Data Inversion	OFF	Data Not Inverted
SW2-4	V.54/CSU select	OFF	V.54 RDL loop
SW2-5	FPS enabled	OFF	Enabled
SW2-6	V.54 Response	OFF	Enabled
SW2-7	Not Used	OFF	N/A
SW2-8	Not Used	OFF	N/A

### SWITCH SW2-1 LINE CODING: HDB3 (DEFAULT)

Use Switch SW2-1 to control the Network Line Coding options. Set these options to be the same as the Line Coding given to you by

your Service Provider. If you are using two Model 2701/Is together as short range modems, set both units to HDB3.

<u>SW2-1</u>	<u>Line Encoding</u>
OFF	HDB3
ON	AMI

#### OPTIONS: **HDB3, AMI**

**HDB3:** In this line coding, the transmitter substitutes a deliberate bipolar violation when excessive zeros in the data stream are detected. The receiver recognizes these special violations and decodes them as zeros. This method enables the network to meet minimum pulse density requirements. Unless AMI is required in your application, HDB3 should be used whenever possible.

**AMI:** Alternate Mark Inversion defines a pulse as a "mark," a binary one, as opposed to a zero. In an E1 network connection, signals are transmitted as a sequence of ones and zeros. Ones are sent as pulses, and zeros are sent as spaces, i.e., no pulse. Every other pulse is inverted from the previous pulse in polarity, so that the signal can be effectively transmitted. This means, however, that a long sequence of zeros in the data stream will cause problems, since the NTU receiving the signal relies on the signal to recover the 2.048 Mb/s clock.

If you must use AMI, you should ensure that the data terminal equipment connected to the unit provides a minimally acceptable pulse density. For this reason, there are advantages to using HDB3 instead. AMI coding does not inherently account for ones density. To meet this requirement, the user should ensure that the data inherently meets pulse density requirements.

#### **SWITCH SW2-2: CRC-4 MULTIFRAME**

In framed mode, SW2-2 is used for CRC-4 MF. When CRC-4 is enabled, the unit monitors the incoming data stream for CRC-4 errors. It transmits CRC-4 error counts to the transmitting unit. When using timeslot zero (TS0), excessive errors may cause loss of frame or loss of sync. If CRC-4 MF is used, both units must be set for set for CRC-4 MF. Otherwise, the one using CRC-4 MF will detect loss of sync.

<u>SW2-2</u>	<u>Option</u>
Off	CRC-4 Disabled
On	CRC-4 Enabled

**NOTE:** When the data rate is set to 2.048Mb/s, then the unit is forced into G.703 mode, and it transmits user data on all 32 time-slots. There is no framing information; therefore, the CRC4 MF (SW2-2) switch is ignored. In all other rate settings, the unit employs G.704 framing; TS0 is reserved for signaling.

#### **SWITCH SW2-3 DATA INVERSION**

Set Switch S2-3 to determine whether or not the data stream from the local DTE is inverted within the Model 2701/I before being passed to the G.703/G.704 network. An inverted data stream may be required when you use the Model 2701/I to communicate with a G.703 device (that inverts the data) on the remote end. In typical installations, data inversion is not necessary.

<u>SW2-3</u>	<u>Option</u>
Off	Data not inverted
On	Data inverted

#### **SWITCH SW2-4: REMOTE DIGITAL LOOPBACK TYPE**

The user can set this variable to select the type of remote loop that will be initiated by the Model 2701/I. If set to V.54, the Model 2701/I will initiate a V.54 loop when Remote Loop is selected by the front panel switches. If set to CSU, the Model 2701/I will initiate a CSU loop when Remote Loop is selected by the front panel switches.

<u>S2-4</u>	<u>RDL Type</u>
Off	Initiate a V.54 RDL loop when selected
On	Initiate a CSU loopback when selected

#### **SWITCH SW2-5 FRONT PANEL SWITCHES**

As the Front Panel Switches may be inadvertently toggled, or in the event that the end-user may not need to use the switches, the installer may disable the front panel switches. Set Switch S2-5 to determine whether the front-panel toggle switches are active or inactive.

<u>SW2-5</u>	<u>Option</u>
Off	Front Panel Switches Enabled
On	Front Panel Switches Disabled

## SWITCH SW2-6: V.54 RESPONSE ENABLED (DEFAULT)

V.54 is a special in-band loopback facility that sends a pseudo-random pattern over the data stream. This is the only loopback that the unit can initiate. This is useful for campus applications when you need to put a remote unit in loopback. The unit responds to the V.54 loopback command, and the whole process takes only a few seconds to complete. When V.54 Loopback is disabled, the unit will not be able to respond to V.54 loopback commands.

<u>SW2-6</u>	<u>Option</u>
Off	V.54 Response Enabled
On	V.54 Response Disabled

## 5.0 INSTALLATION

Once the Model 2701/I is properly configured, it is ready to connect to the G.703/G.704 interface, to the Ethernet port, and to the power source. This section describes how to make these connections.

### 5.1 CONNECTING TO THE G.703 NETWORK

The Power, G.703/G.704 and Ethernet Line connections are located on the rear panel of the Model 2701/I. Figure 5, below, shows the location of each of these ports.

#### 5.1.1 Connecting Dual Coaxial Cable (75 ohm) to the G.703 Network

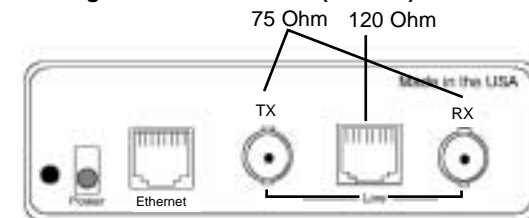

Figure 5. Model 2701/I Rear Panel

The Model 2701/I is equipped with dual female BNCs (TX and RX) for connection to a 75 ohm dual coax G.703 network interface. If your G.703/G.704 network terminates via dual coaxial cable, use the diagram below to make the proper connections. See Figure 6 below.

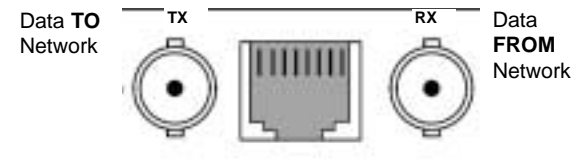

Figure 6: Rear Panel, Showing Location of Connectors.

**NOTE:** The outer conductor of the coax cables are isolated from system earth ground.

When using the 75 Ohm interface, jumper straps JP2, JP5, JP6, and JP7 must be installed over the jumpers. The jumpers are located next to the BNC connectors. Refer to the following section to open the case. Open the case and install jumper straps for JP2, JP5, JP6, and JP7.

### 5.1.2 Opening the Case

Open the case by inserting a screwdriver into the slots and twist the screwdriver head slightly. The top half of the case will separate from the lower half of the case. Take caution not to damage any of the PC board mounted components.

### 5.1.2 Connecting the Twisted Pair (120 ohm) to the G.703 Network

The Model 2701/I is equipped with a single RJ-48C jack for connections to a 120 ohm twisted pair G.703/G.704 network interface. If your G.703/G.704 network terminates via RJ-48C, use the connection diagram (Figure 7) following the pinout and signals chart below to connect the 120 ohm G.703/G.704 network channel.

#### RJ-45 Cable (8-Wire)

G.703/G.704 NETWORK SIGNAL	PIN#	2701/I SIGNAL
RX+	1	TX+
RX-	2	TX-
TX+	5	RX+
TX-	4	RX-
Shield	3	Shield
Shield	6	Shield

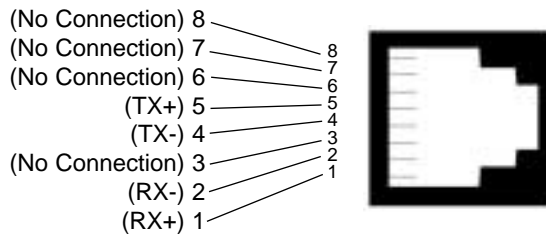

Figure 7: G.703/G.704 170 Ohm Connection.

### 5.2 Connecting the 10Base-T Ethernet Port to a PC (DTE)

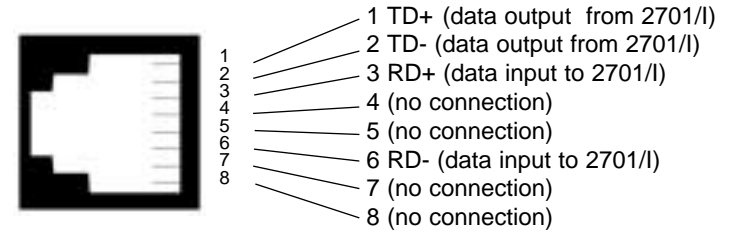

Figure 8: Connecting the 10Base-T Ethernet Port to a PC

The 10Base-T interface is configured as DTE (Data Terminal Equipment). If the Model 2701/I is to connect to another DTE device such as a 10Base-T network interface card, construct a 10Base-T crossover cable and connect the wires as shown in the diagram below (Figure 8).

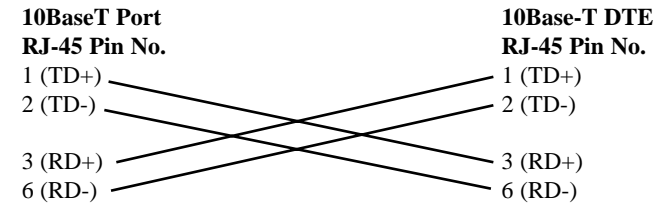

Figure 8: 10Base-T Cross-over Cable Connection

### 5.3 Connecting the 10Base-T Ethernet Port to a Hub

The 10Base-T interface is configured as DTE (Data Terminal Equipment), just like a 10Base-T network interface card in a PC. Therefore, it "expects" to connect to a 10Base-T Hub using a straight-through RJ-45 cable. Use the diagram below (Figure 9) to construct a cable to connect the 10 BaseT interface to a 10Base-T Hub.

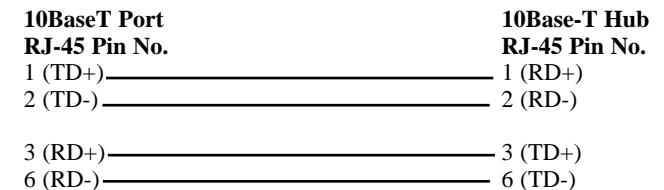

Figure 9: Connecting the 10Base-T Ethernet Port to a Hub



## 5.4 POWER CONNECTION

### Universal AC Power (100-240VAC)

The Model 2701/I uses a 5VDC, 2A universal input 100-240VAC, power supply (center pin is +5V). The universal input power supply has a male IEC-320 power entry connector. This power supply connects to the Model 2701/I by means of a barrel jack on the rear panel. Many international power cords are available for the universal power supply.

The Model 2701/I powers up as soon as it is plugged into an AC outlet--there is no power switch.

### DC Power

The 36-60 VDC DC to DC adapter supplied with the DC version of the Model 2701/I plugs in a DC source (nominal 48VDC) and plugs into the barrel power supply jack on the rear of the 2701/I. Please refer to Figure 10, below, to make the proper connection.



Figure 10: Connecting DC Power to the 2701/I DC Power Supply.

**WARNING!** There are no user-serviceable parts in the power supply section of the Model 2701/I. For more information, please contact Patton Electronics Technical Support at (301)975-1007, via our web site at <http://www.patton.com>, or by e-mail at [support@patton.com](mailto:support@patton.com).

## 6.0 OPERATION

When the Model 2701/I has been properly configured and installed, it should operate transparently. This sections describes power-up, LED status monitors, and the built-in loopback test modes.

### 6.1 POWER-UP

Before applying power to the Model 2701/I, please read **Section 5.4 and ensure** that the unit is properly connected to the appropriate power source.

### 6.2 LED STATUS MONITORS

The Model 2701/I features six front panel LEDs that monitor connections on the G.703/G.704 and 10BaseT links, signaling, error and test modes. Figure 11 (below) shows the front panel location of each LED. Descriptions of each LED follow Figure 11.

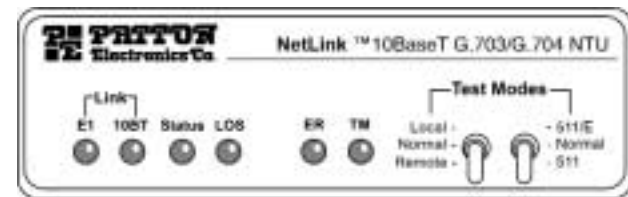

Figure 11: 2701/I Front Panel

- E1 Link** (Active Green) Solid green (On) indicates that the end to end E1 Link is up, signifying that the link is active. The E1 Link LED is Off when the link is down.
- 10BT Link** (Active Green) Solid green indicates that the 10BaseT Ethernet interface has detected a valid SQE heartbeat, signifying a valid 10BaseT connection.
- Status** Blinks yellow from one to eleven times to indicate system status. Each pulse pattern is separated by a 2 second "off" period. Greater pulse patterns have higher priority (buffer saturation has greater priority than an empty MAC table). Valid system statuses are:

1 pulse = system status is okay  
 2 pulses = no MAC entries in the MAC Address Table

- 3 pulses = Clear to Send (CTS) or Carrier Detect (DCD) from base unit are not asserted
- 4 pulses = IM1/I buffer is saturated
- 5 pulses = WAN receive frame(s) too large
- 6 pulses = WAN receive frame(s) not octet aligned
  
- 7 pulses = WAN receive frame(s) aborted
- 8 pulses = Detected WAN receive frame(s) with CRC
- 9 pulses = Detected LAN receive frame(s) too large
- 10 pulses = Detected LAN receive frame(s) not octet aligned
- 11 pulses = Detected LAN receive frame(s) with bad CRC

**LOS** The Loss of Sync LED lights when the unit loses synchronization with the incoming signal. This may happen when there is a framing mismatch or a loss of signal. In unframed mode, the LOS LED monitors the status of the transmit clock.

**ER** The error LED indicates various error conditions, including framing bit errors, excessive zeros, controlled slips, severe errors, or bit errors (when sending V.52 test patterns). When sending a test pattern, the LED will remain lit if the unit does not receive the identical pattern. When it receives the correct pattern, the LED will turn off. If error insertion is on, the LED will blink once a second if everything is operating properly.

**TM** (Active Yellow) Solid Yellow indicates an Active Test Mode. The unit may be placed in test mode by the local user or by the remote user.

## 6.2 LOOP (V.54 & TELCO) DIAGNOSTICS

The Model 2701/I offers three V.54 loop diagnostics. Use these diagnostics to test the NTU and any communication links. These tests can be activated via the front panel switches.

### 6.2.1 Operating Local Loopback (LL)

The Local Loopback (LL) test checks the operation of the local Model 2701/I, and is performed separately on each unit.

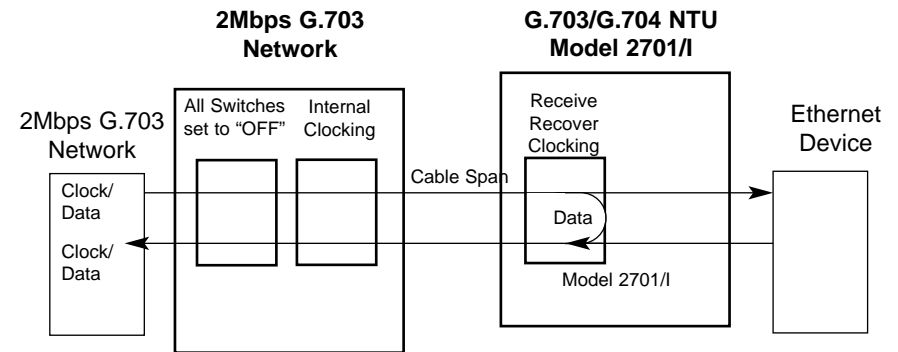

Figure 12. Local Loopback for a Network Termination Application

To perform a LL test, follow these steps:

1. Activate LL. This may be done by selecting local loop on the front panel switch.
2. Perform a V.52 BER (bit error rate) test as described in **Section 6.2.4**. If the BER test equipment indicates no faults, but the data terminal indicates a fault, follow the manufacturer's checkout procedures for the data terminal. Also, check the interface cable between the terminal and the Model 2701/I.

### 6.2.2 Operating Remote Digital Loopback (RL)

The Remote Digital Loopback (RL) test checks the performance of both the local and remote NetLink-E1™, as well as the communication link between them. Any characters sent to the remote NetLink-E1™ in this test mode will be returned back to the originating device.

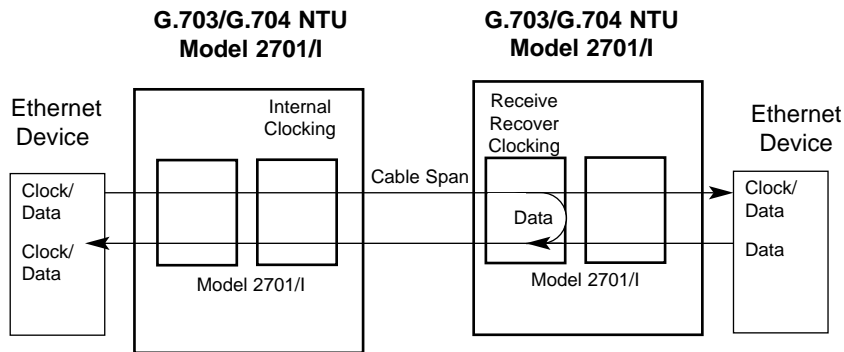

Figure 13. Remote Loop in a Network Extension Application

There are two Remote Loops that can be initiated from the NetLink 2701/I unit: (1) V.54 Loop, and; (2) CSU Loop. The user can select the type of loop that can be initiated by Switch S2-4. When a loopback is initiated this is the type of loop that the unit uses to loop up the remote unit and which type of loop the unit will respond to.

To perform an RDL test, follow these steps:

1. Activate RDL. This may be done by setting the front panel switch to 'Remote'.
2. Perform a bit error rate test (BERT) using the internal V.52 generator (as described in **Section 6.2.4**), or using a separate BER Tester. If the BER test indicates a fault, and the Local Line Loopback test was successful for both NetLink™s, you may have a problem with the twisted pair line connection.

### 6.2.3 CSU Loop

Although CSU Loop is predominantly a T1 function, the NetLink-2701/I responds to central office initiated loop commands. Customers can use this facility when the Central Office network switch supports CSU loops over an E1 interface.

When CSU Loop is selected, and when in D4 framing mode, the NetLink 2701/I will implement the "loop up" command when it recognizes the pattern "10000" in the data stream for a minimum of 5 seconds. The "loop down" command is implemented by the pattern "100" in the data stream for a minimum of 5 seconds.

The NetLink 2701/I will respond to Universal Loopback De-activate to clear all central office loops.

### 6.2.4 Using the V.52 (BER) Test Pattern Generator

To use the V.52 BER tests in conjunction with the Remote Digital Loopback tests (or with Local Line Loopback tests), follow these instructions:

1. Locate the "511/511E" toggle switch on the front panel of the 2701/I and move it UP. This activates the V.52 BER test mode and transmits a "511" test pattern into the loop. If any errors are present, the local modem's red "ER" LED will blink sporadically.
2. If the above test indicates no errors are present, move the V.52 toggle switch DOWN, activating the "511/E" test with errors present. If the test is working properly, the local modem's red "ER" LED will blink once per second. A successful "511/E" test will confirm that the link is in place, and that the Model 2701/I's built-in "511" generator and detector are working properly.

**NOTE:** The above V.52 BER tests can be used independently of the Remote Digital Loopback tests. This requires two operators: one to initiate and monitor the tests at the local Model 2701/I, and one to do the same at the remote Model 2701/I. In this case, the test pattern sent by each Model 2701/I will not be looped back, but will be transmitted down the line to the other Model 2701/I. While one operator initiates test, the other monitors for errors.

## APPENDIX A

### PATTON MODEL 2701/I

#### G.703/G.704 SPECIFICATIONS

<b>Network Data Rate:</b>	2.048 Mbps
<b>Network Connector:</b>	RJ-48C/Dual Coax BNC
<b>Nominal Impedance:</b>	75/120 ohm
<b>Line Coding:</b>	Selectable AMI or HDB3
<b>Line Framing:</b>	G.703 (Unframed) or G.704/G.732 (Framed)
<b>CRC-4 Multiframeing:</b>	Selectable On or Off
<b>Clocking:</b>	Internal or Network(Receive Recover)
<b>Time Slot Rate:</b>	64 kbps
<b>Network Data Rates:</b>	64, 128, 192, 256, 320,384, 448, 512, 576, 640, 704, 768, 832, 896, 960, 1024, 1088, 1152, 1216, 1280, 1344, 1408, 1472, 1536, 1600, 1664, 1728, 1792, 1856, 1920, 1984, 2048 kbps
<b>Distance:</b>	Maximum 1.8 km (6,000 ft.) on 24 AWG Cable

## APPENDIX B

### ETHERNET 10BASE-T SPECIFICATIONS

<b>DTE Interface:</b>	10Base-T on RJ-45F
<b>DTE Data Rates:</b>	10Mbps
<b>LAN Connection:</b>	RJ-45, 10Base-T, 802.3 Ethernet
<b>Protocol:</b>	PPP (RFC 1661) with Bridging Control (RFC 1638)
<b>MAC Address Table Size:</b>	4096 entries
<b>MAC Address Aging:</b>	MAC addresses deleted after 8 minutes of inactivity
<b>Frame Buffer:</b>	512 Frames
<b>Frame Latency:</b>	1 frame
<b>Diagnostics:</b>	V.54 Loopback; CSU Loopback; V.52 Patterns: 511
<b>Indicators:</b>	E-1 Link, 10Base-T Link, Ethernet Status, Loss of Frame Sync, Error, Test Mode
<b>Configuration:</b>	Two 8-Position DIP Switches
<b>Power Supply:</b>	+5VDC external power supply 100-240VAC, 50-60Hz, 0.4A
<b>Humidity:</b>	Up to 90% non-condensing
<b>Temperature:</b>	0 to 70° C
<b>Dimensions:</b>	9.0 x 5.3 x 2.0 cm (3.5"L x 2.1"W x 0.78"H)

**APPENDIX C**

**PATTON MODEL 2701/I**

**FACTORY REPLACEMENT PARTS  
AND ACCESSORIES**

<u>Patton Model #</u>	<u>Description</u>
2701/B.....	G.703/G.704 NTU with RS-530 interface
2701/C.....	G.703/G.704 NTU with a V.35 interface
2701/D.....	G.703/G.704 NTU with an X.21 interface
2701/I.....	G.703/G.704 NTU with 10Base-T ethernet interface
08055DCUI.....	Universal Input Power Supply
07M2701/I.....	User Manual