

Operating Instructions (Basic) AC Servo Motor & Driver MINAS A5-series (400V)



- Thank you for purchasing this Panasonic product.
- Before operating this product, please read the instructions carefully, and save this manual for future use.

* This product image is 1.5kW type of A5-series.

If you are the first user of this product, please be sure to read the downloaded Operating Instructions (Overall) from our Web Site.

[Web address of Motor Business Unit, Panasonic Corporation]

http://industrial.panasonic.com/ww/i_e/25000/motor_fa_e/motor_fa_e.html

Make sure to forward these Operating Instructions for safety to the final user.

<Contents>		page	page
1. Introduction	B2		
On Opening the Product Package	B2	Wiring to the Connector, X5	B25
Check of the Driver Model	B2	Wiring to the Connector, X6	B26
Check of the Motor Model	B3	Wiring to the Connector, X7	B28
2. Installation	B4	4. Parameter	B29
Driver	B4	Outline / Setup / Connection	B29
Motor	B6	Composition of Parameters	B31
3. System Configuration and Wiring	B8	5. Protective Functions	B32
Overall Wiring (Connector type)	B8	Protective Function (What Is Error Code ?)	B32
Overall Wiring (Terminal block type)	B10	6. Maintenance and Inspections	B34
Driver and List of Applicable Peripheral Equipments	B12	7. Conformity to EC Directives and UL Standards	B36
Wiring of the Main Circuit (Connector type)	B14	Composition of Peripheral Equipments	B38
Wiring of the Main Circuit (Terminal block type)	B15	8. Built-in Holding Brake	B42
Wiring method to connector	B16	9. Dynamic Brake	B44
Wiring Diagram	B18	10. Check of the Combination of the Driver and the Motor	B45
Wiring of connector for motor and brake	B19	Incremental Specifications, 20-bit	B45
Wiring to the Connector, X1	B20	Absolute Specifications, 17-bit	B46
Wiring to the Connector, X2	B20	11. Specifications	B47
Wiring to the Connector, X3	B21	After-Sale Service (Repair)	B50
Wiring to the Connector, X4	B22		

1. Introduction

On Opening the Product Package

- Make sure that the model is what you have ordered.
- Check if the product is damaged or not during transportation.
- Check if the Operating Instructions (safety) are included or not.
- Check if the power connector, motor connectors, connector for external regenerative resistor connection (only D and E-frame) and safety by-pass plug are included or not. (Neither the power connector nor motor connector are included to F-frame.)

1. Introduction

Check of the Driver Model

Contents of Name Plate

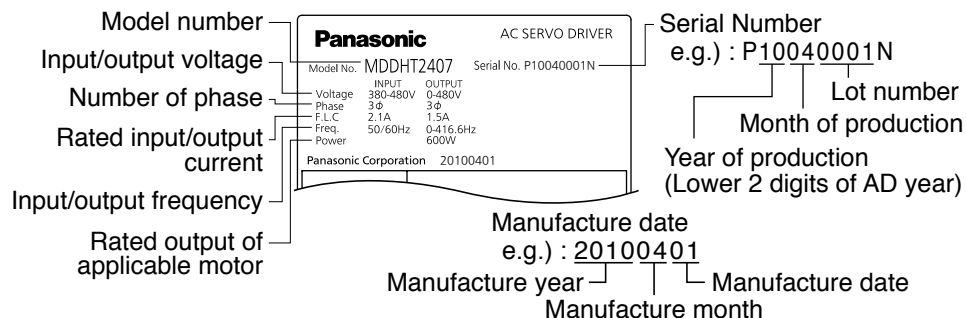

Model Designation

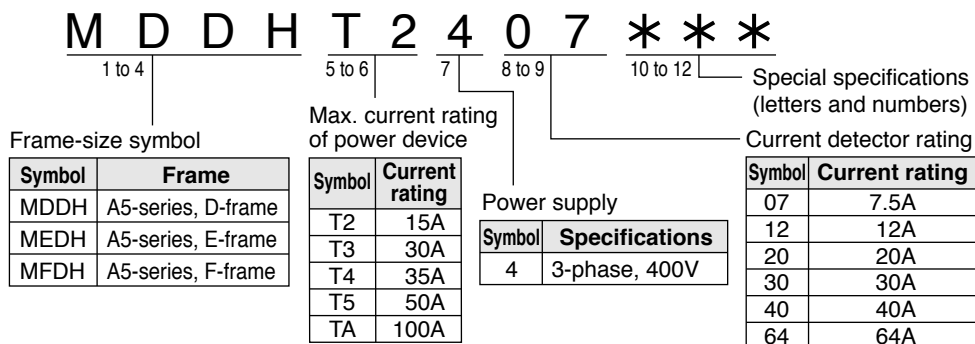

1. Introduction

Check of the Motor Model

Contents of Name Plate

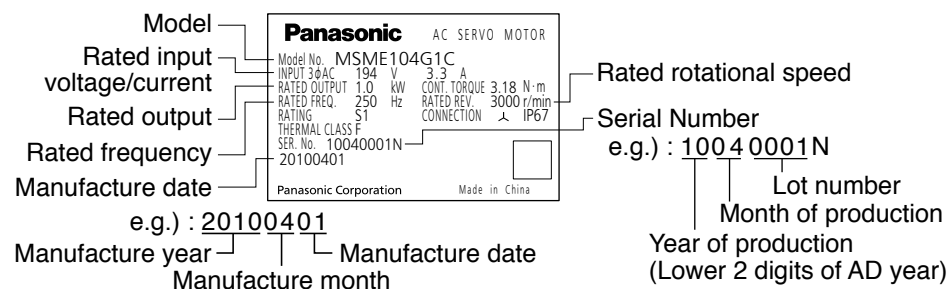

Model Designation

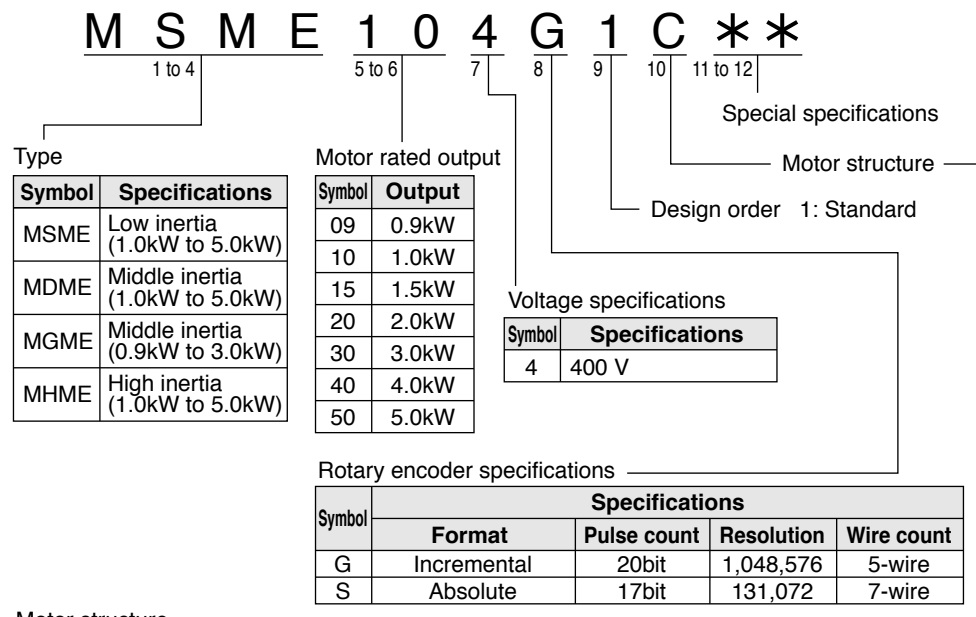

Motor structure MSME, MDME, MGME, MHME

Symbol	Shaft		Holding brake		Oil seal	
	Round	Key way	Without	With	Without	With
C	●		●			●
D	●			●		●
G		●	●			●
H		●		●		●

Products are standard stock items or manufactured by order. For details, inquire the dealer.

2. Installation

Driver

Install the driver properly to avoid a breakdown or an accident.

Installation Place

- 1) Install the driver in a control panel enclosed in noncombustible material and placed indoor where the product is not subjected to rain or direct sunlight. The products are not waterproof.
- 2) Where the products are not subjected to corrosive atmospheres such as hydrogen sulfide, sulfurous acid, chlorine, ammonia, sulfur, chloric gas, sulfuric gas, acid, alkaline and salt and so on, and are free from splash of inflammable gas.
- 3) Where the motor is free from grinding oil, oil mist, iron powder or chips.
- 4) Well-ventilated and low humidity and dust-free place.
- 5) Vibration-free place.

Environmental Conditions

Item	Conditions
Ambient temperature	0°C to 55°C (free from freezing)
Ambient humidity	20% to 85% RH (free from condensation)
Storage temperature*1	-20°C to 65°C (Max.temperature guarantee: 80°C for 72 hours)
Storage humidity	20% to 85% RH (free from condensation)
Vibration	Lower than 5.88m/s ² (0.6G), 10 to 60Hz
Altitude	Lower than 1000m

*1 Extreme temperatures are permissible only for short period such as during transportation.

How to Install

- 1) Rack-mount type. Install in vertical position, and reserve enough space around the servo driver for ventilation.
- 2) Base mount (rear mount) is standard for D-frame driver.
- 3) To change the mounting surface of D-frame driver, use the optional mounting fixture. For choosing the correct optional mounting fixture, refer to the Operating Instructions (Overall).
- 4) For the dimensions and mass of the product, which are necessary design data of the mounting section, refer to the dimensional outline drawing on the Operating Instructions (Overall) or the Delivery Specification.

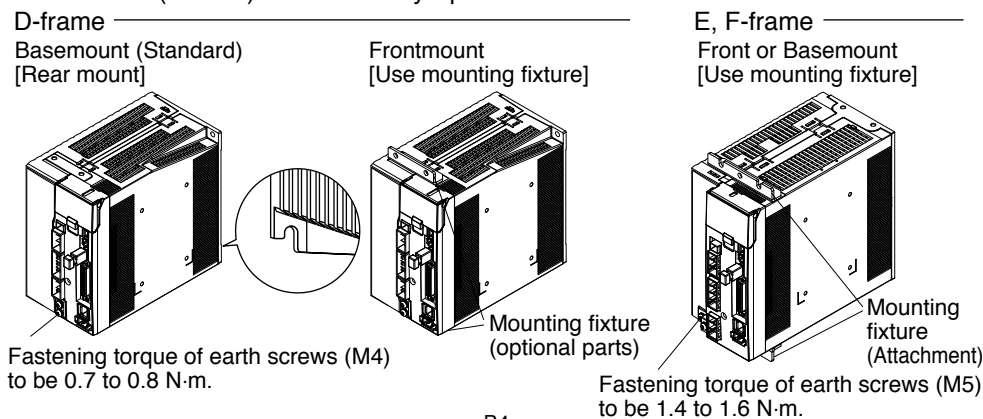

2. Installation

Driver

Mounting Direction and Spacing

- Reserve enough surrounding space for effective cooling.
- Install fans to provide uniform distribution of temperature in the control panel.
- D/E/F frame is provided with a cooling fan at the bottom.
- Observe the environmental conditions of the control panel described in the previous page.

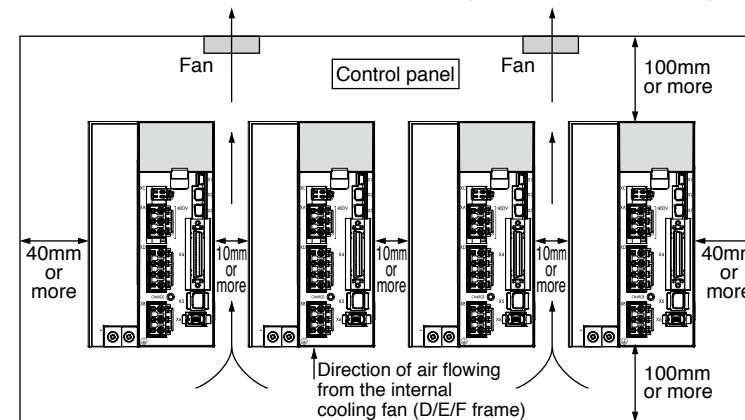

Note It is recommended to use the conductive paint when you make your own mounting fixture, or repaint after peeling off the paint on the machine for installing the products, in order to make noise countermeasure.

Caution on Installation

- We have been making the best effort to ensure the highest quality, however, application of exceptionally large external noise disturbance and static electricity, or failure in input power, wiring and components may result in unexpected action. It is highly recommended that you make a fail-safe design and secure the safety in the operative range.
- If stranded wires are used as the cable, bunch the conductors of the cable using a ferrule. If stranded wires are used as they are, unexpected accidents such as an electric shock and short circuit or injury may result. (Refer to P.B16. "Wiring method to connector".)
- There might be a chance of smoke generation due to the failure of these products. Pay an extra attention when you apply these products in a clean room environment.
- Be sure to ground the protective earth terminal.
If the product is grounded insufficiently, not only the driver may not deliver its performance sufficiently, but also safety hazards such as a malfunction due to a electrification or a disturbance may be caused.
- If electric wires are bound and run through metal duct, they cannot carry the rated current due to temperature rise. If they are forced to carry the rated current, they may burn. When determining size of the wire, check the current decreasing coefficient by referring to the Operating Instructions (Overall).

2. Installation

Motor

Install the motor properly to avoid a breakdown or an accident.

Installation Place

Since the conditions of location affect a lot to the motor life, select a place which meets the conditions below.

- 1) Indoors, where the products are not subjected to rain or direct sun beam. The products are not waterproof.
- 2) Where the products are not subjected to corrosive atmospheres such as hydrogen sulfide, sulfuric acid, chlorine, ammonia, sulfur, chloric gas, sulfuric gas, acid, alkaline and salt and so on, and are free from splash of inflammable gas.
- 3) Where the motor is free from grinding oil, oil mist, iron powder or chips.
- 4) Well-ventilated and humid and dust-free place, far apart from the heat source such as a furnace.
- 5) Easy-to-access place for inspection and cleaning
- 6) Vibration-free place.
- 7) Avoid enclosed place. Motor may get hot in those enclosure and shorten the motor life.

Environmental Conditions

Item	Conditions	
Ambient temperature*1	0°C to 40°C (free from freezing)	
Ambient humidity	20% to 85% RH (free from condensation)	
Storage temperature*2	-20°C to 65°C (Max.temperature guarantee: 80°C for 72 hours)	
Storage humidity	20% to 85% RH (free from condensation)	
Vibration	Motor only	Lower than 49m/s ² (5G) at running, 24.5m/s ² (2.5G) at stall
Impact	Motor only	Lower than 98m/s ² (10G)
Enclosure rating	Motor only (Connector type)	IP67 (except rotating portion of output shaft and connecting pin part of the motor connector and the encoder connector)*3
Altitude		Lower than 1000m

*1 Ambient temperature to be measured at 5cm away from the motor.

*2 Permissible temperature for short duration such as transportation.

*3 These motors conform to the test conditions specified in EN standards (EN60529, EN60034-5). Do not use these motors in application where water proof performance is required such as continuous wash-down operation.

How to Install

You can mount the motor either horizontally or vertically as long as you observe the followings.

- 1) Horizontal mounting
 - Mount the motor with cable outlet facing downward for water/oil countermeasure.
- 2) Vertical mounting
 - Use the motor with oil seal when mounting the motor with gear reducer to prevent the reducer oil/grease from entering to the motor.

2. Installation

Motor

- 3) For the dimensions and mass of the product, which are necessary design data of the mounting section, refer to the dimensional outline drawing on the Operating Instructions (Overall) or the Delivery Specification.

Oil/Water Protection

- 1) Don't submerge the motor cable to water or oil.
- 2) Install the motor with the cable outlet facing downward.
- 3) Avoid a place where the motor is always subjected to oil or water.
- 4) Use the motor with an oil seal when used with the gear reducer, so that the oil may not enter to the motor through shaft.

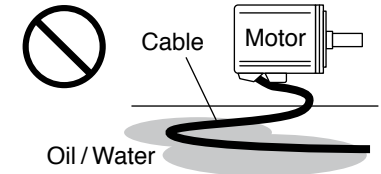

Stress to Cables

- 1) Avoid a stress application to the cable outlet and connecting portion by bending or self-weight.
- 2) Especially in an application where the motor itself travels, fix the attached cable and contain the extension junction cable into the bearer so that the stress by bending can be minimized.
- 3) Take the cable bending radius as large as possible. (Minimum R20mm)

Permissible Load to Output Shaft

- 1) Design the mechanical system so that the applied radial load and/or thrust load to the motor shaft at installation and at normal operation can meet the permissible value specified to each model.
- 2) Pay an extra attention when you use a rigid coupling. (Excess bending load may damage the shaft or deteriorate the bearing life.)
- 3) Use a flexible coupling with high stiffness designed exclusively for servo application in order to make a radial thrust caused by micro misalignment smaller than the permissible value.

Notes on Installation

- 1) Do not apply direct impact to the shaft by hammer while attaching/detaching a coupling to and from the motor shaft. (Or it may damage the encoder mounted on the other side of the shaft.)
- 2) Make a full alignment. (incomplete alignment may cause vibration and damage the bearing.)
- 3) If the motor shaft is not electrically grounded, it may cause electrolytic corrosion to the bearing depending on the condition of the machine and its mounting environment, and may result in the bearing noise. Check and verification by customer is required.

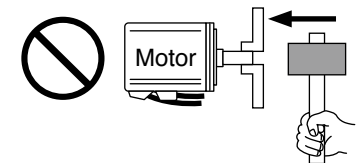

3. System Configuration and Wiring

Overall Wiring (Connector type)

Connecting Example of D, E-frame, 400 V type

• Wiring of Main Connector (XA)

Circuit Breaker (MCCB)

To protect power supply line from overloading, install a wiring circuit breaker rated to the capacity of the power supply.

Noise Filter (NF)

Removes external noise from the power lines. And reduces an effect of the noise generated by the servo driver.

Magnetic Contactor (MC)

Turns on/off the main power of the servo driver.

Use coil surge suppression units together with this.

• **Never start nor stop the servo motor with this Magnetic Contactor.**

Reactor (L)

Reduces harmonic current of the main power.

• Wiring of External Components (XC)

Pin B1 (4-pin), B2 (2-pin), and B3 (3-pin)

• B2 and B3 to be kept shorted for normal operation.

• When you connect an external regenerative resistor, disconnect a short circuit wire between B2 and B3, then connect the external regenerative resistor between B1 and B2, set up Pr0.16 to 1 or 2.

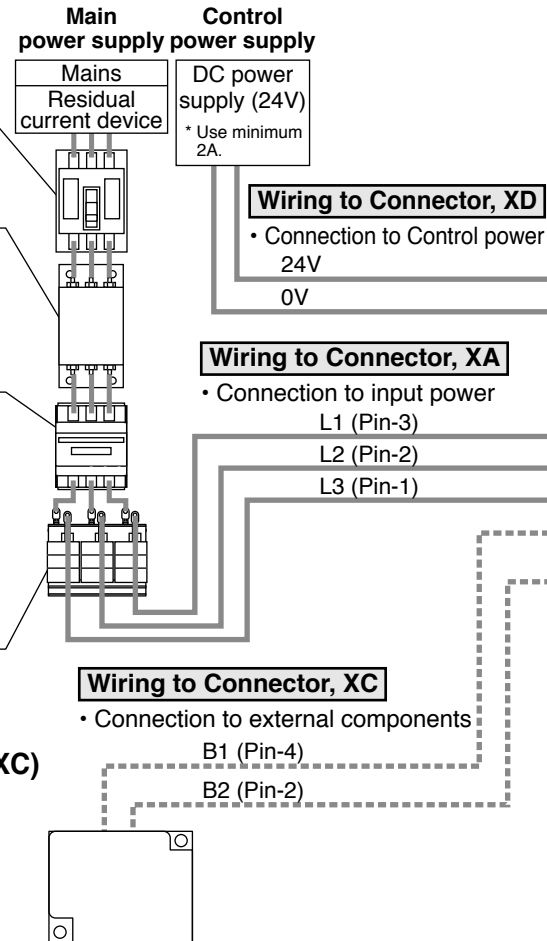

Regenerative resistor (optional)

Remarks

- When you use an external regenerative resistor, install an external protective apparatus, such as thermal fuse without fail.
- Thermal fuse and thermostat are built in to the regenerative resistor (Option). If the thermal fuse is activated, it will not resume.
- Mount the regenerative resistor on incombustible material such as metal.

3. System Configuration and Wiring

Overall Wiring (Connector type)

: High voltage

Wiring to Connector, X7

- Monitor output

Handle lever
Use this for connector connection. Store this after connection for other occasions. (Refer to P.B16 for connection.)

PC (to be supplied by customer)

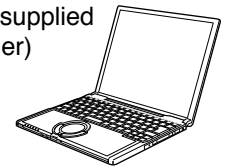

Setup support software "PANATERM"
Please download from our web site.

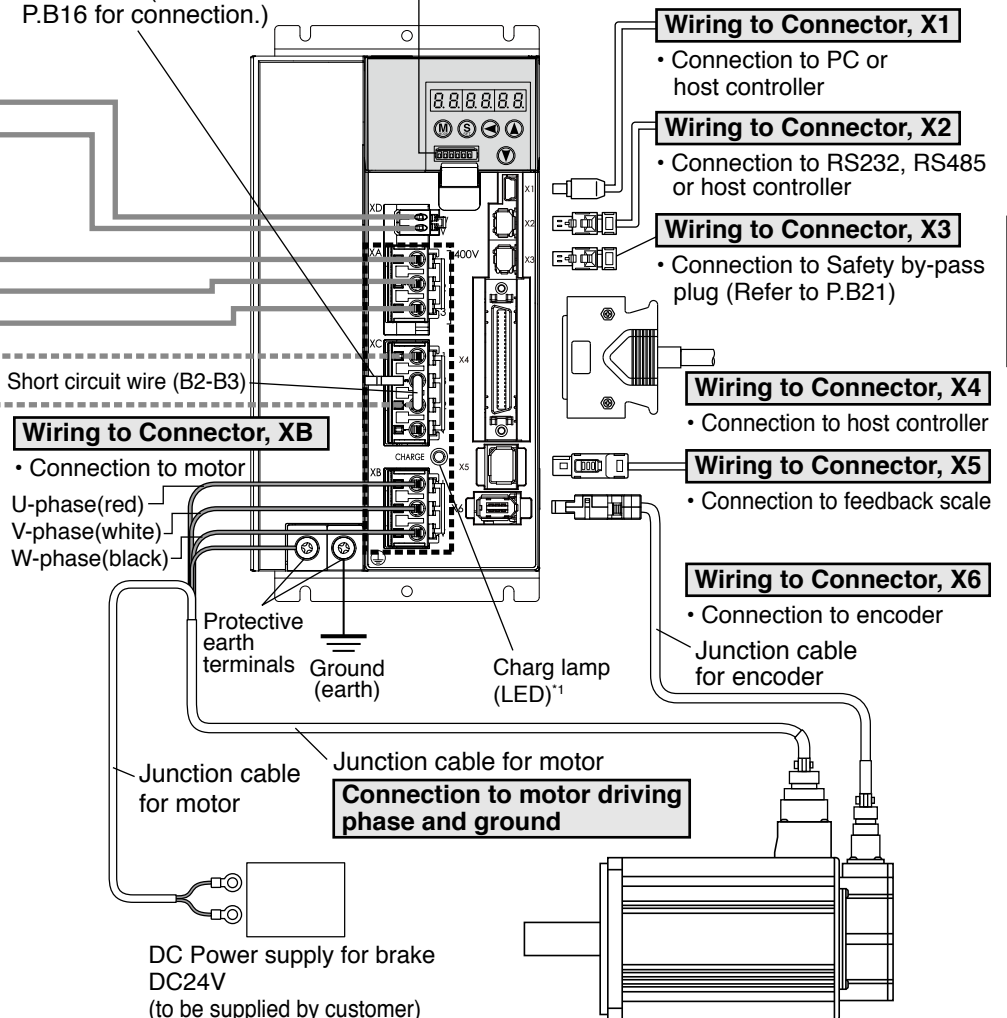

*1 Do not make displacement, wiring or inspection while the LED is lit - cause of electric shock.

3. System Configuration and Wiring

Overall Wiring (Terminal block type)

Connecting Example of F-frame, 400 V type

• Wiring of Main Connector (XA)

Circuit Breaker (MCCB)

To protect power supply line from overloading, install a wiring circuit breaker rated to the capacity of the power supply.

Noise Filter (NF)

Removes external noise from the power lines. And reduces an effect of the noise generated by the servo driver.

Magnetic Contactor (MC)

Turns on/off the main power of the servo driver.

Use coil surge suppression units together with this.

• **Never start nor stop the servo motor with this Magnetic Contactor.**

Reactor (L)

Reduces harmonic current of the main power.

• Wiring of the Main Circuit

Pin B1, B2 and B3

- B1 and B2 to be kept shorted for normal operation.
- When you connect an external regenerative resistor, disconnect a short bar between B1 and B2, then connect the external regenerative resistor between P and B2, set up Pr0.16 to 1 or 2.

Pin NC

- Do not connect anything.

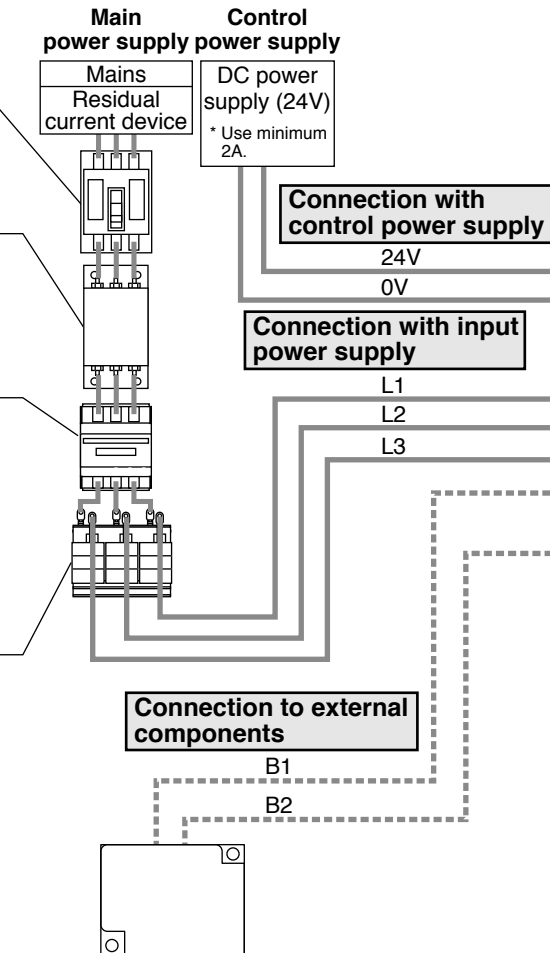

Regenerative resistor (optional)

Remarks

- When you use an external regenerative resistor, install an external protective apparatus, such as thermal fuse without fail.
- Thermal fuse and thermostat are built in to the regenerative resistor (Option). If the thermal fuse is activated, it will not resume.
- Mount the regenerative resistor on incombustible material such as metal.

3. System Configuration and Wiring

Overall Wiring (Terminal block type)

⊞ : High voltage

PC (to be supplied by customer)

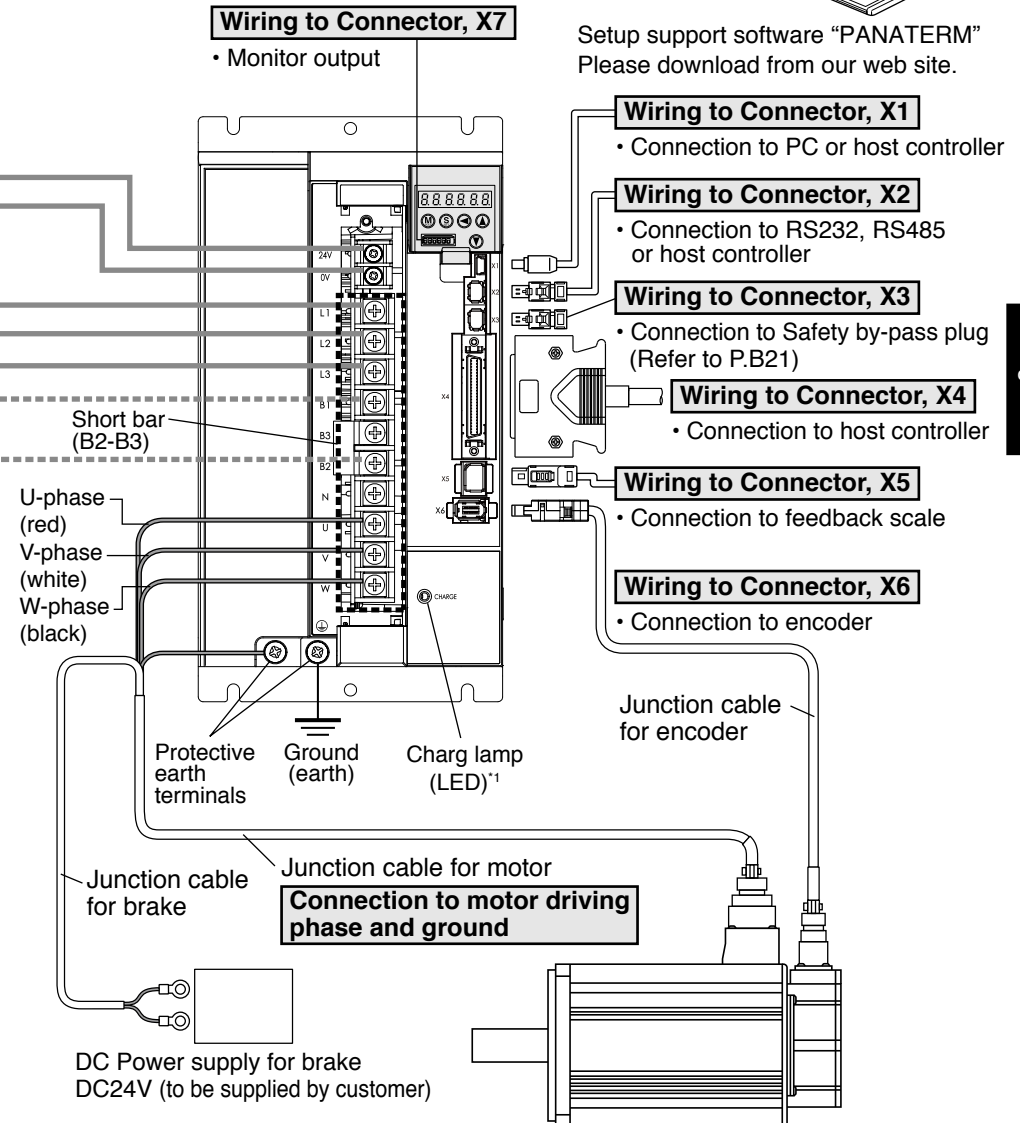

Setup support software "PANATERM"
Please download from our web site.

Wiring to Connector, X7

- Monitor output

Wiring to Connector, X1

- Connection to PC or host controller

Wiring to Connector, X2

- Connection to RS232, RS485 or host controller

Wiring to Connector, X3

- Connection to Safety by-pass plug (Refer to P.B21)

Wiring to Connector, X4

- Connection to host controller

Wiring to Connector, X5

- Connection to feedback scale

Wiring to Connector, X6

- Connection to encoder

*1 Do not make displacement, wiring or inspection while the LED is lit - cause of electric shock.

3. System Configuration and Wiring

Driver and List of Applicable Peripheral Equipments

Driver	Applicable motor	Voltage	Rated output	Required Power (at the rated load)	Circuit breaker (rated current)	Surge absorber	Noise filter for signal	Magnetic contactor	Cable diameter (main circuit)	Cable diameter (control circuit)	Connection	
MDDH	MSME	3-phase, 400V	1.0kW	approx. 1.8kVA	10A	DV0PM 20050		20A (3P+1a)	2.0mm ² / AWG14	0.5mm ² / AWG 20 to 24	Connection to exclusive connector	
	MDME											
	MHME											
	MGME		0.9kW									
	MSME											
	MDME		1.5kW	approx. 2.3kVA								
MHME												
MEDH	MSME	3-phase, 400V	2.0kW	approx. 3.3kVA	15A	DV0PM 20050		30A (3P+1a)	0.5mm ² / AWG 20 to 24			
	MDME											
	MHME											
MFDH	MGME	3-phase, 400V	2.0kW	approx. 3.8kVA	30A	DV0PM 20050	DV0P 1460	60A (3P+1a)	3.5mm ² / AWG12	0.75mm ² / AWG18		 Terminal block M5
	MSME											
	MDME		3.0kW	approx. 4.5kVA								
	MGME											
	MHME		4.0kW	approx. 6.8kVA								
	MSME											
	MDME		5.0kW	approx. 7.5kVA								
	MHME											
	MSME											
	MDME											
MHME												

3. System Configuration and Wiring

Driver and List of Applicable Peripheral Equipments

- Select peripheral equipments for single/3phase common specification according to the power source.

[For details of peripheral equipments]

Noise filter P.B39

Surge absorber P.B39

Noise filter for signal lines P.B40

- About circuit breaker and magnetic contactor

To comply to EC Directives, install a circuit breaker between the power and the noise filter without fail, and the circuit breaker should conform to IEC Standards and UL recognized (Listed and  marked).

Suitable for use on a circuit capable of delivering not more than 5,000Arms symmetrical amperes, below the maximum input voltage of the product.

Remarks ❄

- Select a circuit breaker and noise filter which match to the capacity of power supply (including a load condition).
- Terminal block and protective earth terminals
 - Use a copper conductor cables with temperature rating of 75°C or higher.
 - The screws of protective earth terminals for Frame D are M4 and M5 for Frame E, F. Tighten the terminal block screw on frame F with a torque between 1.0 and 2.0 N·m. Application of overtorque (more than 2.0 N·m) will cause damage to terminal block. Maximum allowable torque to the screw securing terminal block cover is 0.2 N·m.
- The cable diameter of an earth cable.
 - Use an earth cable with the same diameter or larger as that of the main circuit cable.
 - If the diameter of the main circuit cable is 1.6mm² or less, use an earth cable with a diameter of 2.0mm² (AWG14).
- Use the attached exclusive connector for D, E-frame, and maintain the peeled off length of 8 to 9mm. (Refer to P.B16)
- Tighten the screws of the connector, Connector X4 for the host controller with the torque of 0.3 to 0.35 N·m.
 - Larger torque than 0.35N·m may damage the connector at the driver side.

Caution ❄

Do not turn on power without tightening all terminal block screws properly, otherwise, loose contacts may generate heat (smoking, firing).

3. System Configuration and Wiring

Wiring of the Main Circuit (Connector type)

D, E-frame

- Wiring should be performed by a specialist or an authorized personnel.
- Do not turn on the power until the wiring is completed.

• Tips on Wiring

- 1) Wire connector (XA, XB, XC and XD).
- 2) Connect the wired connector to the driver.

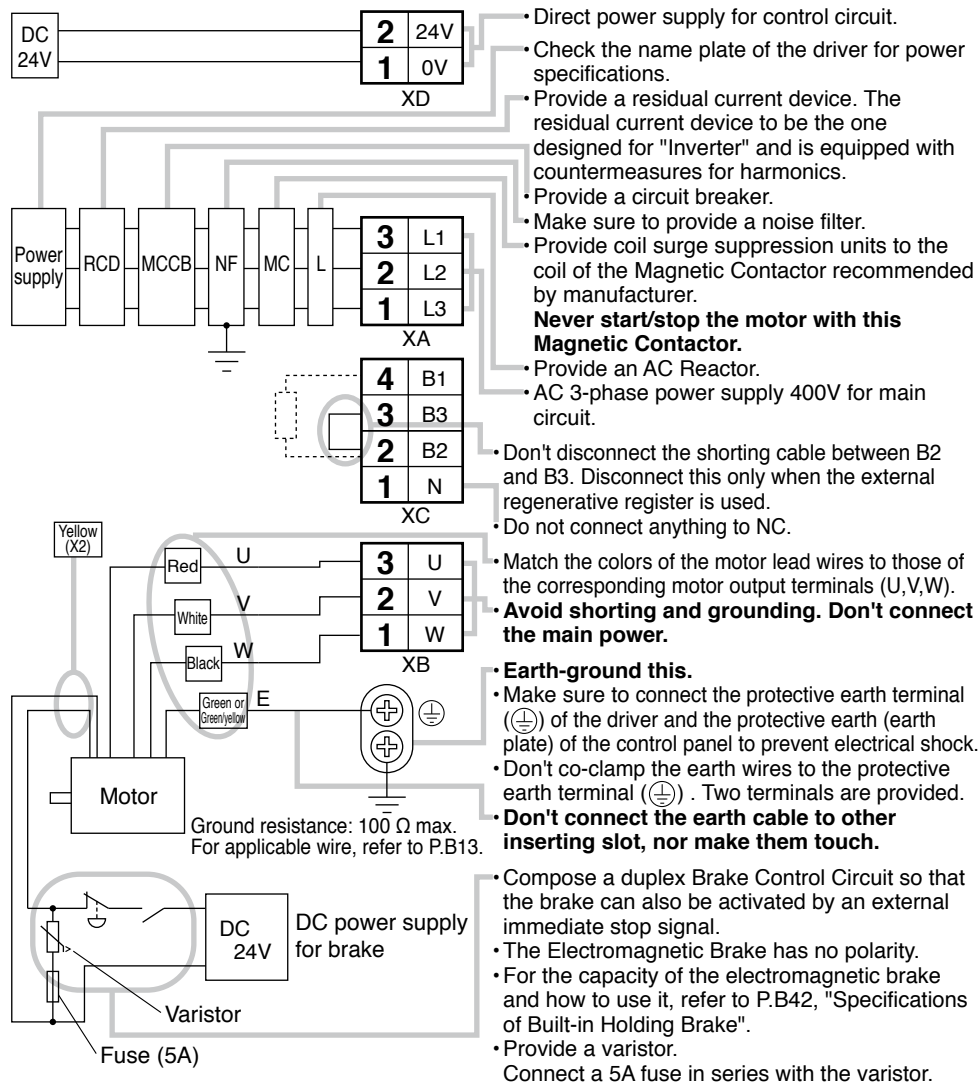

3. System Configuration and Wiring

Wiring of the Main Circuit (Connector type)

F-frame

- Wiring should be performed by a specialist or an authorized personnel.
- Do not turn on the power until the wiring is completed.

• Tips on Wiring

- 1) Take off the cover fixing screws, and detach the terminal cover.
- 2) Make wiring

Use clamp type terminals of round shape with insulation cover for wiring to the terminal block. For cable diameter and size, refer to "Driver and List of Applicable Peripheral Equipments" (P.B12).

Tighten the terminal block screw with a torque between 1.0 and 2.0 N·m.

- 3) Attach the terminal cover, and fix with screws.

Tighten the screw securing the cover with a torque between 0.1 and 0.2 N·m.

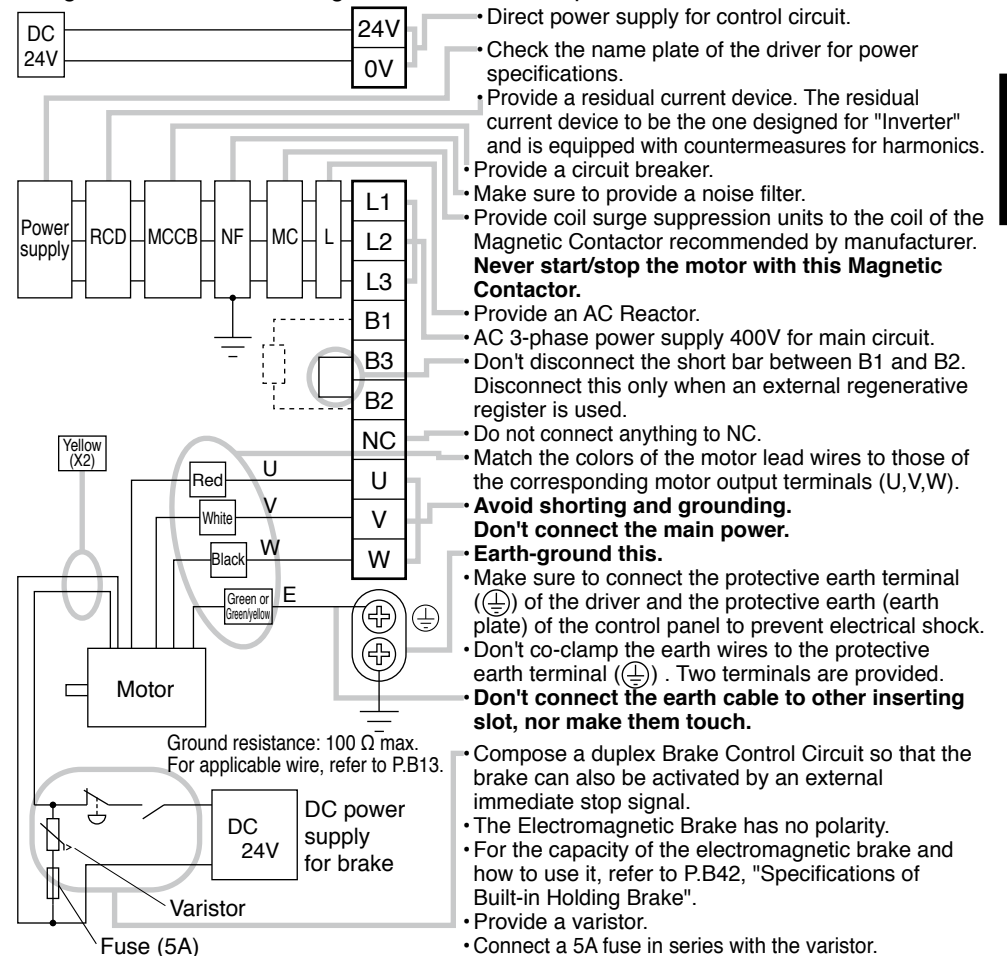

3. System Configuration and Wiring

Wiring method to connector

- Follow the procedures below for the wiring connection to the Connector **[XA]**, **[XB]**, **[XC]** and **[XD]**.

How to connect

- Peel off the insulation cover of the cable.

- For single wire (Please obey the length in figure.)

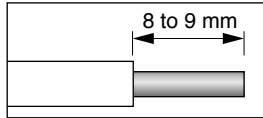

- For stranded wires (Use of short tube e.g. ferrule is recommended.)

Example: Ferrules with plastic insulating sleeve (AI series, Phoenix Contact, Ltd.)



- Peel off the sheath so that the conductor portion of the cable will protrude from the tip of the ferrule. (It should protrude 1 mm or more from the ferrule.)

- Insert the cable into the ferrule and crimp it with an appropriate crimping tool.

- After crimping, cut off the cable conductor portion protruding from the ferrule. (The allowable protruding length after cutting should be 0 to 0.5 mm.)

- Part No. of the crimping tool:

CRIMPFOX U-D66 (1204436) Available from Phoenix Contact, Ltd.

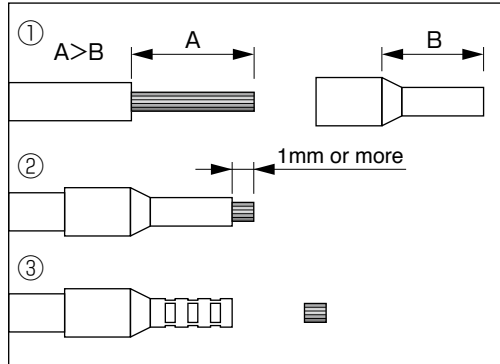

- Caution**
- When peeling off the sheath of the cable, take care not to damage other portions.
 - When crimping the ferrule, sufficiently check the status of the ferrule and cable. If the conductors of the cable stick out from the insulation cover or protrude excessively from the tip of the ferrule, accidents such as an electric shock and fire from a short circuit may result.

3. System Configuration and Wiring

Wiring method to connector

- Insert the cable (the ferrule) to the connector in the following 2 methods.

- Insert the cable using the supplied handle lever.
- Insert the cable using a flat-blade screwdriver (Edge width: 3.0 to 3.5 mm).

(a) Using handle lever

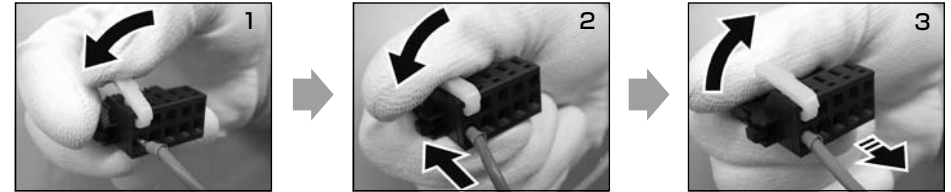

Attach the handle lever to the handling slot on the upper portion. Press down the lever to push down the spring.

Insert the peeled cable (the ferrule) while pressing down the lever, until it hits the insertion slot (round hole).

Release the lever.

* You can pull out the cable by pushing down the spring as the above.

(b) Using screw driver

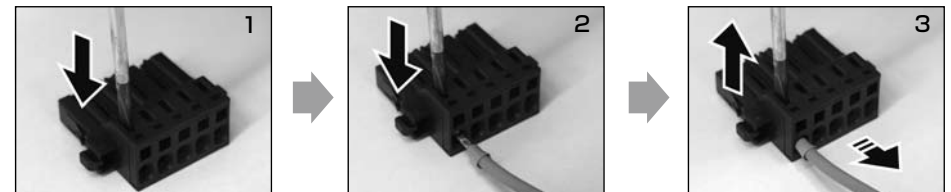

Press the screw driver to the handling slot on the upper portion to push down the spring.

Insert the peeled cable (the ferrule) while pressing down the screw driver, until it hits the insertion slot (round hole).

Release the screw driver.

- Caution**
- Take off the connector from the Servo Driver before making connection.
 - Insert only one cable into each one of cable insertion slot.
 - Pay attention to injury by screw driver.

3. System Configuration and Wiring

Wiring Diagram

Compose the circuit so that the main circuit power will be shut off when an error occurs.

In Case of 3-Phase, D, E-frame, 400 V type

Power supply 3-phase, 380V $\begin{matrix} +10\% \\ -15\% \end{matrix}$ to 480V $\begin{matrix} +10\% \\ -15\% \end{matrix}$

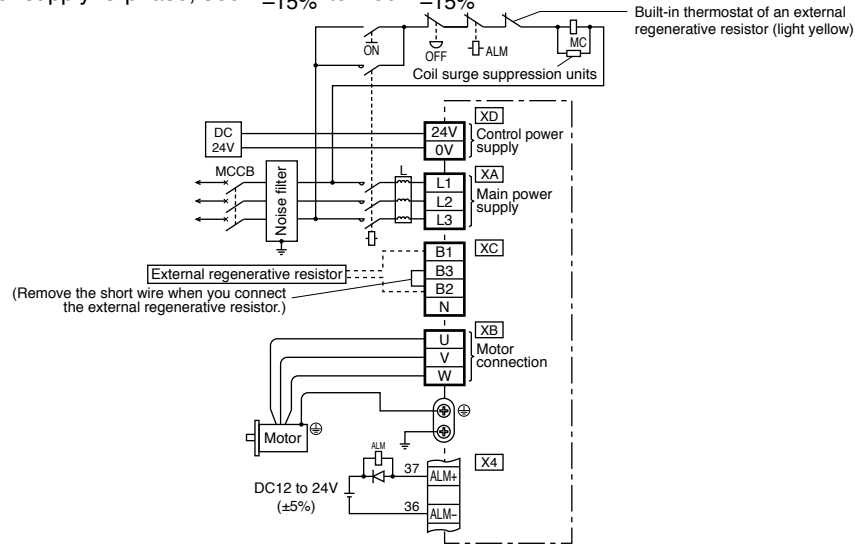

In Case of 3-Phase, F-frame, 400 V type

Power supply 3-phase, 380V $\begin{matrix} +10\% \\ -15\% \end{matrix}$ to 480V $\begin{matrix} +10\% \\ -15\% \end{matrix}$

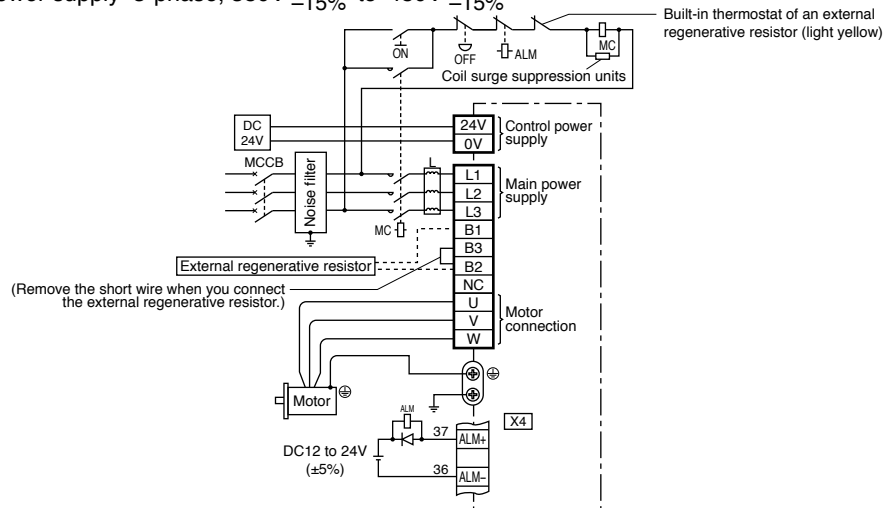

Note For wiring the motor connector, refer to next page.

3. System Configuration and Wiring

Wiring of connector for motor and brake

• When the motors of <MSME, MDME, MGME, MHME> are used, they are connected as shown below.

Connector: Made by Japan Aviation Electronics Industry, Ltd.
(The figures below show connectors for the motor.)

<without Brake>

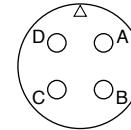

JL04V-2E20-4PE-B-R
JL04HV-2E22-22PE-B-R

PIN No.	Application
A	U-phase
B	V-phase
C	W-phase
D	Ground

<with Brake>

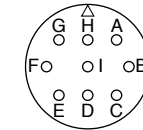

JL04V-2E20-18PE-B-R

PIN No.	Application
G	Brake
H	Brake
A	NC
F	U-phase
I	V-phase
B	W-phase
E	Ground
D	Ground
C	NC

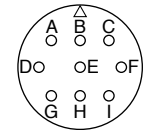

JL04V-2E24-11PE-B-R

PIN No.	Application
A	Brake
B	Brake
C	NC
D	U-phase
E	V-phase
F	W-phase
G	Ground
H	Ground
I	NC

Remarks Do not connect anything to NC.

3. System Configuration and Wiring

Wiring to the connector, X1

This is used for USB connection to a personal computer. It is possible to change the parameter setting and perform monitoring.

Application	Symbol	Connector Pin No.	Contents
USB signal terminal	VBUS	1	Use for communication with personal computer.
	D-	2	
	D+	3	
	—	4	Do not connect.
	GND	5	Connected to ground of control circuit.

Caution Use commercially available USB mini-B connector for the driver.

3. System Configuration and Wiring

Wiring to the connector, X2

This is used for connection to the host controller when two or more units are used. RS232 and RS485 interfaces are supplied.

Application	Symbol	Connector Pin No.	Contents
Signal ground	GND	1	Connected to ground of control circuit.
NC	—	2	Do not connect.
RS232 signal	TXD	3	RS232 The transmission / reception method.
	RXD	4	
RS485 signal	485-	5	RS485 The transmission / reception method.
	485+	6	
	485-	7	
	485+	8	
Frame ground	FG	Shell	Connected with protective earth terminal in the servo driver.

Connector (plug): 2040008-1 (optional, available from Tyco Electronics AMP)

[Connector pin assignment]



3. System Configuration and Wiring

Wiring to the connector, X3

A safety by-pass plug is supplied as standard equipment. Do not disconnect it in normal times.

Since the standard connector cannot be used when controlling the safety function from the host controller, purchase the optional connector and make connection as shown below.

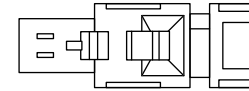

Caution If the connector is disconnected during operation, an immediate stop will be caused.

Application	Symbol	Connector Pin No.	Contents
NC	—	1	Do not connect.
	—	2	
Safety input 1	SF1-	3	These are two independent circuits that turn off the operation signal to the power module to shut off the motor current.
	SF1+	4	
Safety input 2	SF2-	5	
	SF2+	6	
EDM output	EDM-	7	This is an output for monitoring the failure of the safety function.
	EDM+	8	
Frame ground	FG	Shell	Connected with protective earth terminal in the servo driver.

Connector (plug): 2013595-1 (optional, available from Tyco Electronics AMP)

[Connector pin assignment]

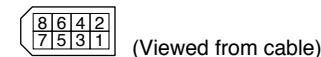

3. System Configuration and Wiring

Wiring to the connector, X4

Wiring Example of Position Control Mode

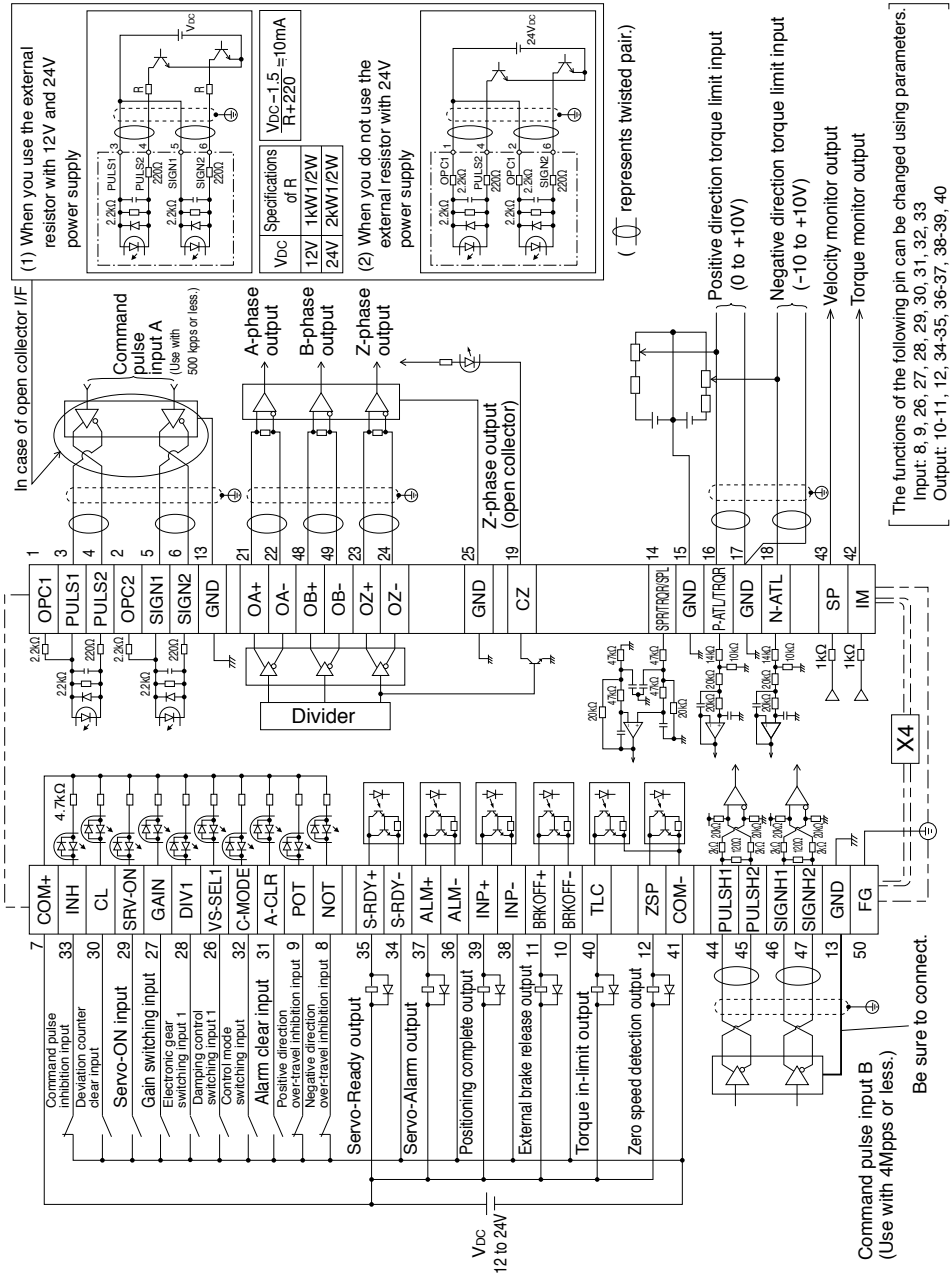

3. System Configuration and Wiring

Wiring to the connector, X4

Wiring Example of Velocity Control Mode

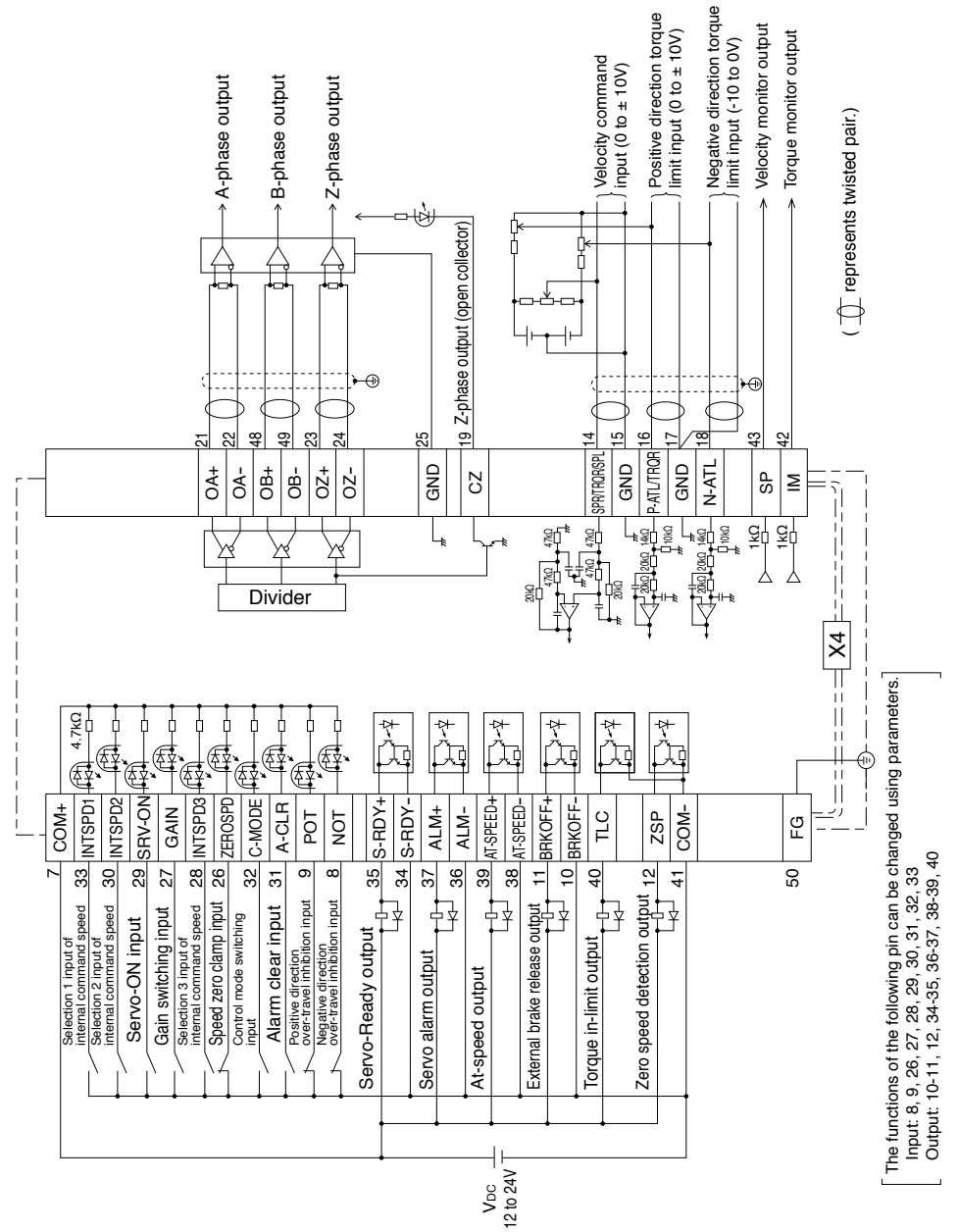

3. System Configuration and Wiring

Wiring to the connector, X4

Wiring Example of Torque Control Mode

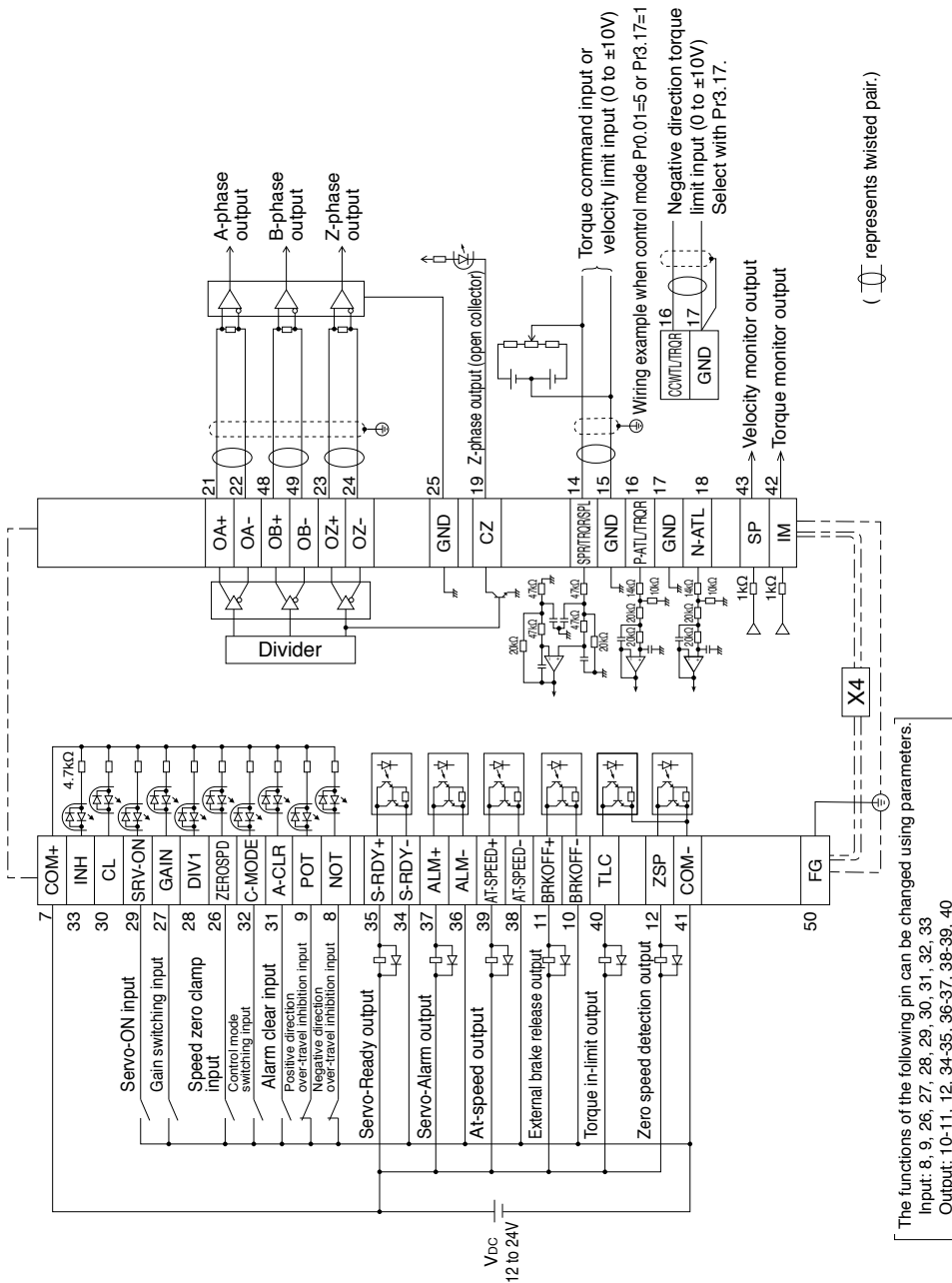

The functions of the following pin can be changed using parameters.
 Input: 8, 9, 26, 27, 28, 29, 30, 31, 32, 33
 Output: 10-11, 12, 34-35, 36-37, 38-39, 40

3. System Configuration and Wiring

Wiring to the connector, X5

Connect on to Feedback Scale

Provide a power supply for the feedback scale on your part or use the following power output (250mA or less).

Application	Symbol	Connector Pin No.	Contents
Power supply output	EX5V	1	Supply the power of feedback scale or A, B, Z phase encoder.
	EX0V	2	Connected to ground of control circuit.
I/F of feedback scale signals	EXPS	3	Serial signal The transmission / reception method.
	/EXPS	4	
A, B, Z phase Encoder signal input	EXA	5	Parallel signal reception
	/EXA	6	
	EXB	7	
	/EXB	8	
	EXZ	9	
	/EXZ	10	
Frame ground	FG	Shell	Connected with protective earth terminal in the servo driver.

Connector (plug): MUF-PK10K-X (by J.S.T. Mfg. Co., Ltd.)

• Caution

1) The manufacturers applicable feedback scales for this product are as follows.

- Mitutoyo Corp.
- Sony Manufacturing Systems Corp.

For the details of the feedback scale product, contact each company.

2) **Recommended feedback scale ratio is $1/40 \leq$ Feedback scale ratio ≤ 160**

If you set up the feedback scale ratio to smaller value than 50/position loop gain (Pr1.00 and Pr.1.05), you may not be able to control per 1 pulse unit. Setup of larger scale ratio may result in larger noise.

3. System Configuration and Wiring

Wiring to the connector, X6

Connection to Encoder

- In case of 20-bit incremental encoder

MSME 1.0kW to 5.0kW
MDME 1.0kW to 5.0kW
MHME 1.0kW to 5.0kW
MGME 0.9kW to 3.0kW

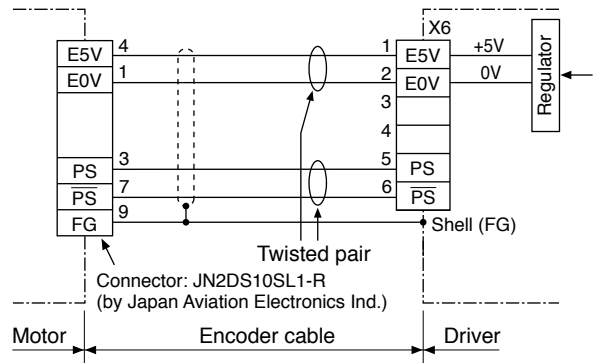

3. System Configuration and Wiring

Wiring to the connector, X6

- In case of 17-bit absolute encoder

MSME 1.0kW to 5.0kW
MDME 1.0kW to 5.0kW
MHME 1.0kW to 5.0kW
MGME 0.9kW to 3.0kW

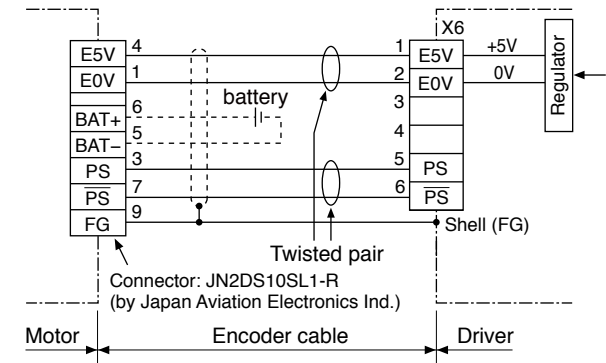

3. System Configuration and Wiring

Wiring to the connector, X7

The connector X7 of the front panel is for monitor output.

Analogue output : 2 systems

Digital output : 1 systems

In both cases, it is possible to switch the output signal by setting parameters.

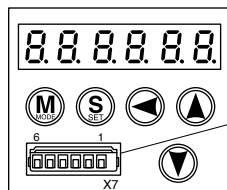

Connector X7
 Manufacturer's part No.: 530140610
 Manufacturer: Japan Molex Inc.

Application	Symbol	Connector Pin No.	Contents
Analogue monitor output 1	AM1	1	Output the analogue signal for monitor.
Analogue monitor output 2	AM2	2	
Signal ground	GND	3	Connected to ground of control circuit.
Digital monitor output	DM	4	Output the digital signal for monitor.
NC	-	5	Do not connect.
NC	-	6	Do not connect.

4. Parameter

Outline / Setup / Connection

Outline of Parameter

This driver is equipped with various parameters to set up its characteristics and functions. This section describes the function and purpose of each parameter. Read and comprehend very well so that you can adjust this driver in optimum condition for your running requirements.

• You can refer and set up the parameter with either one of the following.

- 1) front panel of the driver
- 2) combination of the setup support software, "PANATERM" and PC.

Setup with the Front Panel

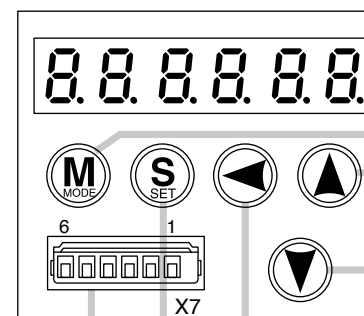

Display LED (6-digit)

Switch to error display screen when error occurs, and LED will flash (about 2Hz). LED will flash slowly (about 1Hz) when warning occurs.

Mode switching button

(valid at SELECTION display)
 Press this to switch 4 kinds of mode.

- 1) Monitor Mode
- 2) Parameter Set up Mode
- 3) EEPROM Write Mode
- 4) Auxiliary Function Mode

SET Button (valid at any time)

Press this to switch SELECTION and EXECUTION display.

Press these to change display and data, select parameters and execute actions. (Change/Selection/Execution is valid to the digit which decimal point flashes.) Numerical value increases by pressing, ▲, decreases by pressing ▼.

Shifting of the digit for data changing to higher digit.

X7
 Output connector for monitor

4. Parameter

Outline / Setup / Connection

Setup with the PC

It is possible to connect your personal computer to connector X1 of MINAS A5 using a USB cable for personal computer connection. Downloading the setup support software "PANATERM" from our web site and installing it on your personal computer will allow you to perform the following easily.

• **With the PANATERM, you can execute the followings.**

- 1) Setup and storage of parameters, and writing to the memory (EEPROM).
- 2) Monitoring of I/O, pulse input and load factor.
- 3) Display of the present alarm and reference of the error history.
- 4) Data measurement of the wave-form graphic and bringing of the stored data.
- 5) Normal auto-gain tuning
- 6) Frequency characteristic measurement of the machine system.

Note Because no production software such as CD-ROM is available, download the setup support software from our web site and install it on your personal computer.

• **How to Connect**

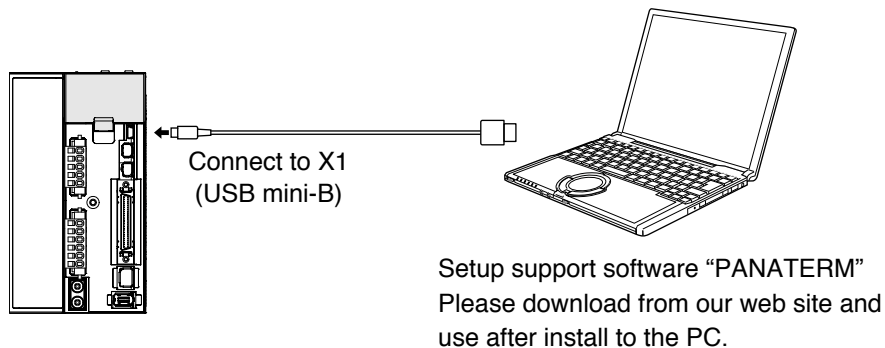

• **USB cable**

On the driver, use commercially available USB mini-B connector.
The connector on the personal computer side should be in accordance with the specifications of the PC.
When the cable does not have noise filter, attach a signal line noise filter (DV0P1460) to both ends of the cable.

4. Parameter

Composition of Parameters

- The parameter No. is displayed in the form of PrX.YY (X: Classification, YY: No.).
- For the details on the parameters, refer to the Operating Instructions (Overall).

Parametr No.		Class name	Group
Class	No.*		
0	00 to	Basic setting	Parameter for Basic setting
1	00 to	Gain adjustment	Parameter for Gain adjustment
2	00 to	Damping control	Parameter for Damping control
3	00 to	Verocity/ Torque/ Full-closed control	Parameter for Verocity/ Torque/ Full-closed control
4	00 to	I/F monitor setting	Parameter for I/F monitor setting
5	00 to	Enhancing setting	Parameter for Enhancing setting
6	00 to	Special setting	Parameter for Special setting

* The Parameter No. consists of 2 digits.

5. Protective Functions

Protective Function (What Is Error Code ?)

- Various protective functions are equipped in the driver. When these are triggered, the motor will stall due to error, the driver will turn the Servo-Alarm output (ALM) to off (open).
- Error status and their measures
 - During the error status, the error code No. will be displayed on the front panel LED, and you cannot turn Servo-ON.
 - You can clear the error status by Alarm clear input(A-CLR) in 120ms or longer.
 - When overload protection is triggered, you can clear it by Alarm clear input(A-CLR) in 10sec or longer after the error occurs. You can clear the Overload protection time characteristics (refer to P.B36, 37) by turning off the control power supply of the driver.*1
 - You can clear the above error by operating the front panel keys and setup support software "PANATERM".
- **The error code No. is displayed in the form of ErrXX.Y (X: main, YY: sub).**

<List of error code No.>

Error code		Protective function	Attribute		
Main	Sub		History	Can be cleared	Immediate stop
11	0	Control power supply under- voltage protection		○	
12	0	Over-voltage protection	○	○	
13	0	Main power supply under-voltage protection (between P to N)		○	
	1	Main power supply under-voltage protection (AC interception detection)		○	
14	0	Over-current protection	○		
	1	IPM error protection	○		
15	0	Over-heat protection	○		○
16	0	Over-load protection	○	○*1	
18	0	Over-regeneration load protection	○		○
	1	Over-regeneration Tr error protection	○		
21	0	Encoder communication disconnect error protection	○		
	1	Encoder communication error protection	○		
23	0	Encoder communication data error protection	○		
24	0	Position deviation excess protection	○	○	○
25	0	Hybrid deviation excess error protection	○		○
26	0	Over-speed protection	○	○	○
	1	2nd over-speed protection	○	○	
27	0	Command pulse input frequency error protection	○	○	○
	2	Command pulse multiplier error protection	○	○	○
28	0	Limit of pulse replay error protection	○	○	○
29	0	Deviation counter overflow protection	○	○	
30	0	Safety detection		○	
33	0	IF overlaps allocation error 1 protection	○		
	1	IF overlaps allocation error 2 protection	○		
	2	IF input function number error 1 protection	○		

5. Protective Functions

Protective Function (What Is Error Code ?)

Error code		Protective function	Attribute		
Main	Sub		History	Can be cleared	Immediate stop
33	3	IF input function number error 2 protection	○		
	4	IF output function number error 1 protection	○		
	5	IF output function number error 2 protection	○		
	6	CL fitting error protection	○		
	7	INH fitting error protection	○		
34	0	Software limit protection	○	○	
36	0 to 2	EEPROM parameter error protection			
37	0 to 2	EEPROM check code error protection			
38	0	Over-travel inhibit input protection		○	
39	0	Analog input1 excess protection	○	○	○
	1	Analog input2 excess protection	○	○	○
	2	Analog input3 excess protection	○	○	○
40	0	Absolute system down error protection	○	○	
41	0	Absolute counter over error protection	○		
42	0	Absolute over-speed error protection	○	○	
43	0	Initialization failure	○		
44	0	Absolute single turn counter error protection	○		
45	0	Absolute multi-turn counter error protection	○		
47	0	Absolute status error protection	○		
48	0	Encoder Z-phase error protection	○		
49	0	Encoder CS signal error protection	○		
50	0	Feedback scale connection error protection	○		
	1	Feedback scale communication error protection	○		
51	0	Feedback scale status 0 error protection	○		
	1	Feedback scale status 1 error protection	○		
	2	Feedback scale status 2 error protection	○		
	3	Feedback scale status 3 error protection	○		
	4	Feedback scale status 4 error protection	○		
	5	Feedback scale status 5 error protection	○		
55	0	A-phase connection error protection	○		
	1	B-phase connection error protection	○		
	2	Z-phase connection error protection	○		
87	0	Compulsory alarm input protection		○	
95	0	Motor automatic recognition error protection			
99	0	Other error	○		

Note

History...The error will be stored in the error history.

Can be cleared...To cancel the error, use the alarm clear input (A-CLR).

If the alarm clear input is not effective, turn off power, remove the cause of the error and then turn on power again.

Immediate stop...Instantaneous controlled stop upon occurrence of an error. (Setting of "Pr.5.10 Sequence at alarm" is also required.)

6. Maintenance and Inspections

Maintenance and Inspections

- Routine maintenance and inspection of the driver and motor are essential for the proper and safe operation.

Notes on Maintenance and Inspection

- 1) Turn on and turn off should be done by operators or inspectors themselves.
- 2) Internal circuit of the driver is kept charged with high voltage for a while even after power-off. Turn off the power and allow 15 minutes or longer after LED display of the front panel has gone off, before performing maintenance and inspection.
- 3) Disconnect all of the connection to the driver when performing megger test (Insulation resistance measurement) to the driver, otherwise it could result in breakdown of the driver.

Inspection Items and Cycles

General and normal running condition

Ambient conditions : 30°C (annual average), load factor of 80% or lower, operating hours of 20 hours or less per day.

Perform the daily and periodical inspection as per the items below.

Type	Cycles	Items to be inspected
Daily inspection	Daily	<ul style="list-style-type: none"> • Ambient temperature, humidity, speck, dust or foreign object • Abnormal vibration and noise • Main circuit voltage • Odor • Lint or other particles at air holes • Cleanness at front portion of the driver and connector • Damage of the cables • Loose connection or misalignment between the motor and machine or equipment • Pinching of foreign object at the load
Periodical inspection	Annual	<ul style="list-style-type: none"> • Loose tightening • Trace of overheat • Damage to the terminal block • Loose fasteners on terminal block

Note Inspection cycle may change when the running conditions of the above change.

6. Maintenance and Inspections

Maintenance and Inspections

Guideline for Parts Replacement

Use the table below for a reference. Parts replacement cycle varies depending on the actual operating conditions. Defective parts should be replaced or repaired when any error have occurred.

 Prohibited	Disassembling for inspection and repair should be carried out only by authorized dealers or service company.
--	---

Product	Component	Standard replacement cycles (hour)	Note
Driver	Smoothing condenser	Approx. 5 years	These hours or cycles are reference. When you experience any error, replacement is required even before this standard replacement cycle.
	Cooling fan	2 to 3 years (10,000 to 30,000 hours)	
	Aluminum electrolytic capacitor (on PCB)	Approx. 5 years	
	Rush current preventive relay	Approx. 100,000 times (depending on working condition)	
	Rush current preventive resistor	Approx. 20,000 times (depending on working condition)	
Motor	Bearing	3 to 5 years (20,000 to 30,000 hours)	
	Oil seal	5000 hours	
	Encoder	3 to 5 years (20,000 to 30,000 hours)	
	Battery for absolute encoder	Life time varies depending on working conditions. Refer to the Operating Instructions attached to the battery for absolute encoder.	

7. Conformity to EC Directives and UL Standards

EC Directives / Conformity to UL Standards

EC Directives

The EC Directives apply to all such electronic products as those having specific functions and have been exported to EU and directly sold to general consumers. Those products are required to conform to the EU unified standards and to furnish the CE marking on the products.

However, our AC servos meet the relevant EC Directives for Low Voltage Equipment so that the machine or equipment comprising our AC servos can meet EC Directives.

EMC Directives

MINAS Servo System conforms to relevant standard under EMC Directives setting up certain model (condition) with certain locating distance and wiring of the servo motor and the driver. And actual working condition often differs from this model condition especially in wiring and grounding. Therefore, in order for the machine to conform to the EMC Directives, especially for noise emission and noise terminal voltage, it is necessary to examine the machine incorporating our servos.

Conformity to UL Standards

Observe the following conditions of (1) and (2) to make the system conform to UL508C (File No. E164620).

- (1) Use the driver in an environment of Pollution Degree 2 or 1 prescribed in IEC60664-1. (e.g. Install in the control box with IP54 enclosure.)
- (2) Make sure to install a circuit breaker or fuse which are UL recognized (Listed ) between the power supply and the noise filter.
For the rated current of the circuit breaker or fuse, refer to P.B12, "Driver and List of Applicable Peripheral Equipments" of Preparation.
Use a copper cable with temperature rating of 75°C or higher.

(3) Over-load protection level

Over-load protective function will be activated when the effective current exceeds 115% or more than the rated current based on the time characteristics (see the next page). Confirm that the effective current of the driver does not exceed the rated current. Set up the peak permissible current with Pr0.13 (Setup of 1st torque limit) and Pr5.22 (Setup 2nd torque limit).

7. Conformity to EC Directives and UL Standards

EC Directives / Conformity to UL Standards

Overload protection time characteristics

MSME 1.0kW~5.0kW
MDME 1.0kW~5.0kW
MHME 1.0kW~5.0kW
MGME 0.9kW~3.0kW

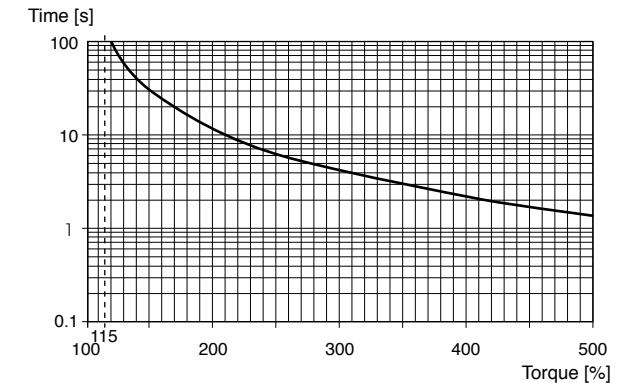

Conformed Standards

		Driver	Motor
EC Directives	EMC Directives	EN55011 EN61000-6-2 EN61800-3	–
	Low-Voltage Directives	EN61800-5-1	IEC60034-1 IEC60034-5
	Functional safety	EN954-1 (Cat. 3) ISO13849-1 (PL d) EN61508 (SIL 2) EN62061 (SIL 2) EN61800-5-2 (STO) IEC61326-3-1	–
UL Standards		UL508C (File No.E164620)	UL1004 (File No.E166557)
CSA Standards		C22.2 No.14	C22.2 No.100

IEC : International Electrotechnical Commission
EN : Europaischen Normen
EMC : Electromagnetic Compatibility
UL : Underwriters Laboratories
CSA : Canadian Standards Association

Pursuant to the directive 2004/108/EC, article 9(2)
Panasonic Testing Centre
Panasonic Service Europe, a division of
Panasonic Marketing Europe GmbH
Winsbergring 15, 22525 Hamburg, F.R. Germany

7. Conformity to EC Directives and UL Standards

Composition of Peripheral Equipments

Installation Environment

Use the servo driver in the environment of Pollution Degree 1 or 2 prescribed in IEC-60664-1 (e.g. Install the driver in control panel with IP54 protection structure.)

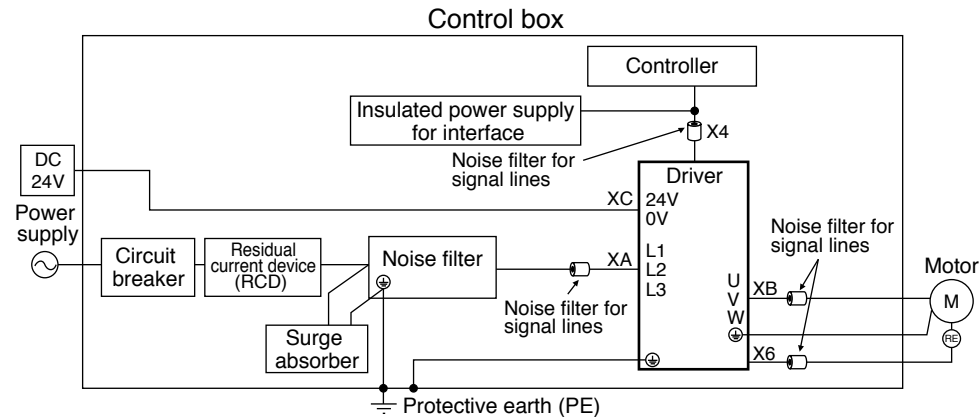

Caution Use options correctly after reading Operating Instructions of the options to better understand the precautions. Take care not to apply excessive stress to each optional part.

Power Supply

• Main power supply

400V type : 3-phase, 380V $+10\%$ to 480V $+10\%$ 50/60Hz
 -15% -15%

• Control power supply

DC 24V $\pm 15\%$

- (1) This product is designed to be used in over-voltage category (installation category) III of EN 61800-5-1:2007.
- (2) Use an insulated power supply of DC12 to 24V which has CE marking or complies with EN60950.

Circuit Breaker

Install a circuit breaker which complies with IEC Standards and UL recognized (Listed and UL marked) between power supply and noise filter.

Integral solid state short circuit protection does not provide branch circuit protection.

Branch circuit protection must be provided in accordance with the National Electrical Code and any additional local codes.

7. Conformity to EC Directives and UL Standards

Composition of Peripheral Equipments

Noise Filter

When you install one noise filter at the power supply for multi-axes application, consult with manufacturer of the noise filter. If sufficient noise margin is required, connect 2 filters in series.

• Recommended components

Model No.	Voltage specifications for driver	Current rating (A)	Manufacturer
FN258L-16-07	3-phase 400V	16	SCHAFFNER
FN258L-30-07		30	

- Remarks**
- Select a noise filter whose capacity is commensurate with the power source capacity (in consideration of the load condition).
 - For the detailed specifications of each noise filter, contact the manufacturer.

Surge Absorber

Provide a surge absorber for the primary side of noise filter.

Option part No.	Voltage specifications for driver	Manufacturer's part No.	Manufacturer
DV0PM20050	3-phase 400V	RAV-801BXZ-4	Okaya Electric Ind.

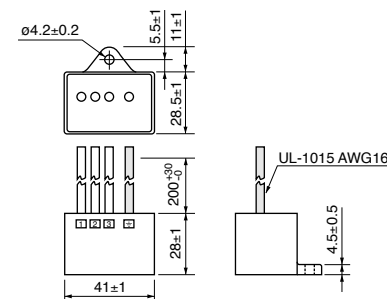

Circuit diagram

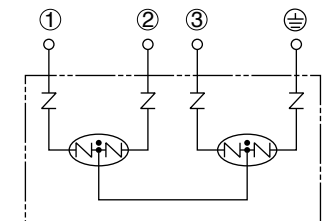

7. Conformity to EC Directives and UL Standards

Composition of Peripheral Equipments

MEMO

Noise Filter for Signal Lines

Install noise filters for signal lines to all cables (power cable, motor cable, encoder cable and interface cable)

Option part No.	Manufacturer's part No.	Manufacturer
DV0P1460	ZCAT3035-1330	TDK Corp.

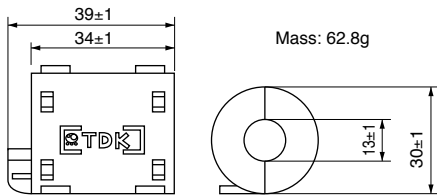

Caution ❄️ Fix the signal line noise filter in order to prevent excessive stress to the cables.

Residual current device

Install a type B Residual current device (RCD) at primary side of the power supply.

Grounding

- (1) Connect the protective earth terminal (⊕) of the driver and the protective earth terminal (PE) of the control box without fail to prevent electrical shocks.
- (2) Do not make a joint connection to the protective earth terminals (⊕). 2 terminals are provided for protective earth.

Note ❄️ For driver and applicable peripheral equipments, refer to P.B12 "Driver and List of Applicable Peripheral Equipments" .

8. Built-in Holding Brake

Outline / Specifications

In the applications where the motor drives the vertical axis, this brake would be used to hold and prevent the work (moving load) from falling by gravity while the power to the servo is shut off.

Use this built-in brake for "Holding" purpose only, that is to hold the stalling status. Never use this for "Brake" purpose to stop the load in motion.

Output Timing of BRK-OFF Signal

- For the brake release timing at power-on, or braking timing at Servo-OFF/Servo-Alarm while the motor is in motion, refer to the Operating Instructions (Overall).
- With the parameter, Pr4.38 (Setup of mechanical brake action while the motor is in motion), you can set up a time between when the motor enters to a free-run from energized status and when BRK-OFF signal turns off (brake will be engaged), when the Servo-OFF or alarm occurs while the motor is in motion. Refer to the Operating Instructions (Overall) for the details.

- Note**
1. The lining sound of the brake (chattering and etc.) might be generated while running the motor with built-in brake, however this does not affect any functionality.
 2. Magnetic flux might be generated through the motor shaft while the brake coil is energized (brake is open). Pay an extra attention when magnetic sensors are used nearby the motor.

8. Built-in Holding Brake

Outline / Specifications

Specifications of Built-in Holding Brake

Motor series	Motor output	Static friction torque N·m	Rotor inertia x 10 ⁻⁴ kg·m ²	Engaging time ms	Releasing time ms	Exciting current DC A (at cool-off)	Releasing voltage	Permissible work (J) per one braking	Permissible total work x 10 ³ ·J	Permissible angular acceleration rad/s ²
MSME	1.0kW, 1.5kW, 2.0kW	7.8 or more	0.33	50 or less	15 or less (100)	0.81	DC2V or more	392	490	10000
	3.0kW	11.8 or more		80 or less						
	4.0kW, 5.0kW	16.2 or more	1.35	110 or less	50 or less (130)	0.9		1470	2200	
MDME	1.0kW	4.9 or more	1.35	80 or less	70 or less (200)	0.59	DC2V or more	588	780	10000
	1.5kW, 2.0kW	13.7 or more		100 or less	50 or less (130)	0.79		1176	1500	
	3.0kW	16.1 or more		110 or less		0.9		1470	2200	
	4.0kW, 5.0kW	24.5 or more	4.7	80 or less	25 or less (200)	1.3		1372	2900	
MHME	1.0kW	4.9 or more	1.35	80 or less	70 or less (200)	0.59	DC2V or more	588	780	10000
	1.5kW	13.7 or more		100 or less	50 or less (130)	0.79		1176	1500	
	2.0kW to 5.0kW	24.5 or more	4.7	80 or less	25 or less (200)	1.3		1372	2900	
MGME	0.9kW	13.7 or more	1.35	100 or less	50 or less (130)	0.79	DC2V or more	1176	1500	10000
	2.0kW	24.5 or more	4.7	80 or less	25 or less (200)	1.3		1372	2900	5440
	3.0kW	58.8 or more		150 or less	50 or less (130)	1.4				

- Excitation voltage is DC24V±10%.
- Releasing time values represent the ones with DC-cutoff using a varistor. Values in () represent those measured by using a diode (V03C by Renesas Technology Corp.)
- Above values (except static friction torque, releasing voltage and excitation current) represent typical values.
- Backlash of the built-in holding brake is kept ±1° or smaller at ex-factory point.
- Service life of the number of acceleration/deceleration with the above permissible angular acceleration is more than 10 million times. (Life end is defined as when the brake backlash drastically changes.)

9. Dynamic Brake

Outline

This driver is equipped with a dynamic brake for emergency stop. Pay a special attention to the followings.

Caution ⚠ 1. Dynamic brake is only for emergency stop.

Do not start/stop the motor by turning on/off the Servo-ON signal (SRV-ON). Otherwise it may damage the dynamic brake circuit of the driver.

The Motor becomes a dynamo when driven externally and short circuit current occurred while dynamic brake is activated may cause smoking or fire.

2. Dynamic brake is a short-duration rating, and designed for only emergency stop. Allow approx. 3 minutes pause when the dynamic brake is activated during high-speed running. (In the case of the F-frame driver, when the built-in dynamic brake circuit overheats, the over current protection (Err14.0) may be activated.)

• **You can activate the dynamic brake in the following cases.**

- 1) when the main power is turned off
- 2) at Servo-OFF
- 3) when one of the protective function is activated.
- 4) when over-travel inhibit input (NOT, POT) of connector X4 is activated

In the above cases from 1) to 4), you can select either activation of the dynamic brake or making the motor free-run during deceleration or after the stop, with parameter.

10. Check of the Combination of the Driver and the Motor

Incremental Specifications, 20-bit

This driver is designed to be used in a combination with the motor which are specified by us. Check the series name of the motor, rated output torque, voltage specifications and encoder specifications.

Caution ⚠ **Do not use in other combinations than those listed below.**

Motor					Driver	
Power supply	Type	Rated rotational speed	Model	Rated output	Model	Frame
3-phase, 400V	MSME Low inertia	3000r/min	MSME104G1*	1.0kW	MDDHT3420	D-frame
			MSME154G1*	1.5kW	MDDHT3420	
			MSME204G1*	2.0kW	MEDHT4430	E-frame
			MSME304G1*	3.0kW	MFDHT5440	F-frame
			MSME404G1*	4.0kW	MFDHTA464	
MSME504G1*	5.0kW	MFDHTA464				
3-phase, 400V	MDME Middle inertia	2000r/min	MDME104G1*	1.0kW	MDDHT2412	D-frame
			MDME154G1*	1.5kW	MDDHT3420	
			MDME204G1*	2.0kW	MEDHT4430	E-frame
			MDME304G1*	3.0kW	MFDHT5440	F-frame
			MDME404G1*	4.0kW	MFDHTA464	
MDME504G1*	5.0kW	MFDHTA464				
3-phase, 400V	MGME Middle inertia	1000r/min	MGME094G1*	0.9kW	MDDHT3420	D-frame
			MGME204G1*	2.0kW	MFDHT5440	F-frame
			MGME304G1*	3.0kW	MFDHTA464	
3-phase, 400V	MHME High inertia	2000r/min	MHME104G1*	1.0kW	MDDHT2412	D-frame
			MHME154G1*	1.5kW	MDDHT3420	
			MHME204G1*	2.0kW	MEDHT4430	E-frame
			MHME304G1*	3.0kW	MFDHT5440	F-frame
			MHME404G1*	4.0kW	MFDHTA464	
MHME504G1*	5.0kW	MFDHTA464				

Note ⚠ Suffix of " * " in the applicable motor model represents the motor structure.

10. Check of the Combination of the Driver and the Motor

Absolute Specifications, 17-bit

This driver is designed to be used in a combination with the motor which are specified by us. Check the series name of the motor, rated output torque, voltage specifications and encoder specifications.

Caution ⚠ Do not use in other combinations than those listed below.

Motor					Driver	
Power supply	Type	Rated rotational speed	Model	Rated output	Model	Frame
3-phase, 400V	MSME Low inertia	3000r/min	MSME104S1*	1.0kW	MDDHT3420	D-frame
			MSME154S1*	1.5kW	MDDHT3420	
			MSME204S1*	2.0kW	MEDHT4430	F-frame
			MSME304S1*	3.0kW	MFDHT5440	
			MSME404S1*	4.0kW	MFDHTA464	
			MSME504S1*	5.0kW		
3-phase, 400V	MDME Middle inertia	2000r/min	MDME104S1*	1.0kW	MDDHT2412	D-frame
			MDME154S1*	1.5kW	MDDHT3420	
			MDME204S1*	2.0kW	MEDHT4430	F-frame
			MDME304S1*	3.0kW	MFDHT5440	
			MDME404S1*	4.0kW	MFDHTA464	
			MDME504S1*	5.0kW		
3-phase, 400V	MGME Middle inertia	1000r/min	MGME094S1*	0.9kW	MDDHT3420	D-frame
			MGME204S1*	2.0kW	MFDHT5440	F-frame
			MGME304S1*	3.0kW	MFDHTA464	
3-phase, 400V	MHME High inertia	2000r/min	MHME104S1*	1.0kW	MDDHT2412	D-frame
			MHME154S1*	1.5kW	MDDHT3420	
			MHME204S1*	2.0kW	MEDHT4430	F-frame
			MHME304S1*	3.0kW	MFDHT5440	
			MHME404S1*	4.0kW	MFDHTA464	
			MHME504S1*	5.0kW		

- Note** ⚠
- Suffix of "*" in the applicable motor model represents the motor structure.
 - Default of the driver is set for the incremental encoder specifications. When you use in absolute, make the following operations.
 - Install a battery for absolute encoder.
 - Switch the parameter Pr0.15 (Absolute encoder setup) from "1 (default)" to "0".

11. Specifications

Basic Specifications

Input power	Main circuit	D to F-frame	3-phase, 380 $\begin{matrix} + 10\% \\ - 15\% \end{matrix}$ to 480V $\begin{matrix} + 10\% \\ - 15\% \end{matrix}$ 50/60Hz
	Control circuit	D to F-frame	DC 24V $\pm 15\%$
Control method			IGBT PWM Sinusoidal wave drive
Encoder feedback			17-bit (131072 resolution) absolute encoder, 7-wire serial 20-bit (1048576 resolution) incremental encoder, 5-wire serial
Feedback scale feedback			A/B phase, initialization signal differential input. Manufacturers that support serial communication scale: Mitsutoyo Corp. Sony Manufacturing Systems Corp.
Control signal	Input	General purpose 10 inputs The function of general-purpose input is selected by parameters.	
	Output	General purpose 6 outputs The function of general-purpose input is selected by parameters.	
Analog /Digital signal	Input	3 inputs (16Bit A/D : 1 input, 12Bit A/D : 2 inputs)	
	Output	3 outputs (Analog monitor: 2 output, Digital monitor: 1 output)	
Pulse signal	Input	2 inputs (Photo-coupler input, Line receiver input)	
	Output	4 outputs (Line driver: 3 output, open collector: 1 output)	
Communication function	USB	Connection with PC etc.	
	RS232	1 : 1 communication	
	RS485	1 : n communication up to 31 axes to a host.	
Safety function			Used for IEC61800-5-2: STO.
Front panel			(1) 5 keys (MODE, SET, UP, DOWN, SHIFT) (2) LED (6-digit) (3) Analog monitor output (2ch) (4) Digital monitor output (1ch)
Regeneration			D to F-frame: Built-in regenerative resistor (external resistor is also enabled.)
Dynamic brake			Built-in
Control mode			Switching among the following 7 mode is enabled, (1) Position control (2) Velocity control (3) Toque control (4) Position/Velocity control (5) Position/Torque control (6) Velocity/Torque control (7) Full-closed control

11. Specifications

Functions

Position control	Control input		(1) Deviation counter clear (2) Command pulse inhibition (3) Command dividing gradual increase switching (4) Damping control switching etc.
	Control output		Positioning complete (In-position) etc.
	Pulse input	Max. command pulse frequency	Exclusive interface for Photo-coupler: 500kpps Exclusive interface for line driver : 4Mpps
		Input pulse signal format	Differential input
		Electronic gear (Division/Multiplication of command pulse)	1/1000 to 1000 times
		Smoothing filter	Primary delay filter or FIR type filter is adaptable to the command input
	Analog input	Torque limit command input	Individual torque limit for both positive and negative direction is enabled.
	Instantaneous Speed Observer		Available
Damping Control		Available	
Velocity control	Control input		(1) Selection of internal velocity setup 1 (2) Selection of internal velocity setup 2 (3) Selection of internal velocity setup 3 (4) Speed zero clamp etc.
	Control output		Speed arrival etc.
	Analog input	Velocity command input	Speed command input can be provided by means of analog voltage. Parameters are used for scale setting and command polarity.
		Torque limit command input	Individual torque limit for both positive and negative direction is enabled.
	Internal velocity command		Switching the internal 8speed is enabled by command input.
	Soft-start/down function		Individual setup of acceleration and deceleration is enabled, with 0 to 10s/1000r/min. Sigmoid acceleration/deceleration is also enabled.
	Zero-speed clamp		Speed zero clamp input is enabled.
	Instantaneous Speed Observer		Available
	Velocity Control filter		Available

11. Specifications

Functions

Torque control	Control input		Speed zero clamp, Torque command sign input etc.	
	Control output		Speed arrival etc.	
	Analog input	Torque command input	Speed command input can be provided by means of analog voltage. Parameters are used for scale setting and command polarity.	
Speed limit function		Speed limit value with parameter t is enabled.		
Full-closed control	Control input		(1) Deviation counter clear (2) Command pulse inhibition (3) Command dividing gradual increase switching (4) Damping control switching etc.	
	Control output		Full-closed positioning complete etc.	
	Pulse input	Max. command pulse frequency	Exclusive interface for Photo-coupler: 500kpps Exclusive interface for line driver : 4Mpps	
		Input pulse signal format	Differential input	
		Electronic gear (Division/Multiplication of command pulse)	1/1000 to 1000 times	
		Smoothing filter	Primary delay filter or FIR type filter is adaptable to the command input	
	Analog input	Torque limit command input	Individual torque limit for both positive and negative direction is enabled.	
	Setup range of division/multiplication of feedback scale		1/40 to 160 times	
	Auto tuning		The load inertia is identified in real time by the driving state of the motor operating according to the command given by the controlling device and internal amplifier. The gain is set automatically in accordance with the rigidity setting.	
	Division of encoder feedback pulse		Set up of any value is enabled (encoder pulses count is the max.).	
Protective function	Hard error	Over-voltage, under-voltage, over-speed, over-load, over-heat, over-current and encoder error etc.		
	Soft error	Excess position deviation, command pulse division error, EEPROM error etc.		
Traceability of alarm data		The alarm data history can be referred to.		
Common				

12. After-Sale Service (Repair)

Repair

Consult to a dealer from whom you have purchased the product for details of repair. When the product is incorporated to the machine or equipment you have purchased, consult to the manufacturer or the dealer of the machine or equipment.

Cautions for Proper Use

- This product is intended to be used with a general industrial product, but not designed or manufactured to be used in a machine or system that may cause personal death when it is failed.
- Installation, wiring, operation, maintenance, etc., of the equipment should be done by qualified and experienced personnel.
- Apply adequate tightening torque to the product mounting screw by taking into consideration strength of the screw and the characteristics of material to which the product is installed. Overtightening can damage the screw and/or material; undertightening can result in loosening.
Example) Steel screw (M5) into steel section: 2.7-3.3 N·m.
- Install a safety equipments or apparatus in your application, when a serious accident or loss of property is expected due to the failure of this product.
- Consult us if the application of this product is under such special conditions and environments as nuclear energy control, aerospace, transportation, medical equipment, various safety equipments or equipments which require a lesser air contamination.
- We have been making the best effort to ensure the highest quality of the products, however, application of exceptionally larger external noise disturbance and static electricity, or failure in input power, wiring and components may result in unexpected action. It is highly recommended that you make a fail-safe design and secure the safety in the operative range.
- If the motor shaft is not electrically grounded, it may cause an electrolytic corrosion to the bearing, depending on the condition of the machine and its mounting environment, and may result in the bearing noise. Checking and verification by customer is required.
- Failure of this product depending on its content, may generate smoke of about one cigarette. Take this into consideration when the application of the machine is clean room related.
- Please be careful when using in an environment with high concentrations of sulfur or sulfuric gases, as sulfuration can lead to disconnection from the chip resistor or a poor contact connection.
- Take care to avoid inputting a supply voltage which significantly exceeds the rated range to the power supply of this product. Failure to heed this caution may result in damage to the internal parts, causing smoking and/or a fire and other trouble.
- The user is responsible for matching between machine and components in terms of configuration, dimensions, life expectancy, characteristics, when installing the machine or changing specification of the machine. The user is also responsible for complying with applicable laws and regulations.

Technical information

Technical information of this product (Operating Instructions, CAD data) can be downloaded from the following web site.

http://industrial.panasonic.com/ww/i_e/25000/motor_fa_e/motor_fa_e.html

For your records:

The model number and serial number of this product can be found on either the back or the bottom of the unit. Please note them in the space provided and keep for future reference.

Model No.	M <input type="checkbox"/> DH _____	Serial No.	
	M <input type="checkbox"/> ME _____		
Date of purchase			
Dealer	Name		
	Address		
	Phone	()	-

Motor Business Unit, Panasonic Corporation

7-1-1 Morofuku, Daito, Osaka, 574-0044, Japan Phone : +81-72-871-1212

Motor Business Unit, Panasonic Corporation

7-1-1 Morofuku, Daito, Osaka, 574-0044, Japan Phone : +81-72-871-1212

© Panasonic Corporation 2009
Printed in China

IMD89
0000-0