

## Operating Instructions



## Table of Contents

---

<b>1 Overview</b>	1.1 General description	5
	1.2 Quick start	6
	1.2.1 Operation via FAULHABER Motion Manager	6
	1.2.2 Operation via own host application	7
<b>2 Installation</b>	2.1 Connections and wiring	8
	2.1.1 Installation instructions	9
	2.1.2 Maintenance	9
	2.1.3 Specialised staff	9
	2.2 RS232 wiring	10
	2.3 Motor connection	11
	2.4 Baud rate and node number	12
	2.5 Basic settings	13
<b>3 Functional Description</b>	3.1 Position control	15
	3.2 Velocity control	16
	3.2.1 Velocity control via RS232	16
	3.2.2 Analog velocity presetting	17
	3.3 Homing and limit switches	19
	3.4 Extended operating modes	22
	3.4.1 Stepper motor mode	22
	3.4.2 Gearing mode (electronic gear)	22
	3.4.3 Analog positioning mode	23
	3.4.4 External encoder as absolute encoder	24
	3.4.5 Voltage regulator mode	24
	3.4.6 Analog target current presetting	25
	3.4.7 IxR control for DC controllers	25
	3.5 Special functions of the error connection	26
	3.6 Sequence programs	27
	3.7 Trace function	32
	3.8 Technical information	33
	3.8.1 Sinus commutation	33
	3.8.2 Current controller and I <sup>2</sup> t current limitation	33
	3.8.3 Over-temperature protection	33
	3.8.4 Undervoltage monitoring	34
	3.8.5 Overvoltage regulation	34
	3.8.6 Adjustment of controller parameters	34

<b>4 Parameter Description</b>	4.1 Basic setting commands	35
	4.1.1 Commands for special operating modes	36
	4.1.2 Parameters for basic settings	36
	4.1.3 General parameters	37
	4.1.4 Configuration of the fault pin and digital inputs	38
	4.1.5 Configuration of homing and limit switches	38
	4.2 Query commands for basic settings	39
	4.2.1 Operating modes and general parameters	39
	4.2.2 Configuration of fault pin and digital inputs	43
	4.2.3 Configuration of homing	43
	4.3 Miscellaneous commands	44
	4.4 Motion control commands	45
	4.5 General query commands	46
	4.6 Commands for sequence programs	47
<b>5 Appendix</b>	5.1 Electromagnetic compatibility (EMC)	49
	5.1.1 Intended use	49
	5.1.2 CE marking	49
	5.2 Configuration at delivery	50
	5.3 Data sheets	53

---

Version:  
2nd edition, 01.07.2006

Firmware versions:  
BC: 605.3150.010  
DC: 605.3150.020

Copyright  
by Dr. Fritz Faulhaber GmbH & Co. KG  
Daimlerstr. 23 · 71101 Schönaich · Germany

All rights reserved, including translation rights.  
No part of this description may be duplicated, reproduced,  
stored in an information system or processed or transferred  
in any other form without prior express written permission  
of Dr. Fritz Faulhaber GmbH & Co. KG.

Although all due care has been taken in the compilation of  
this description, Dr. Fritz Faulhaber GmbH & Co. KG cannot  
accept any liability for any errors in this description or for  
the consequences of such errors. Equally, no liability can  
be accepted for direct or consequential damages resulting  
from misuse of the equipment.

The pertinent regulations regarding safety engineering  
and interference suppression must be complied with.

Subject to modifications.

# 1 Overview

## 1.1 General description

This documentation describes the function and operation of the following devices with serial interface:

### **3564K024B CS**

The 3564K024B CS integrates a brushless DC-Servomotor with a high-resolution absolute encoder and a motion controller in one complete drive unit.

### **MCBL 3003/06 S**

The MCBL 3003/06 S is an external motion controller for brushless DC servomotors with linear Hall sensors, which can be operated without additional encoders.

### **MCDC 3003/06 S**

The MCDC 3003/06 S is an external motion controller that is designed for the entire range of FAULHABER DC micro motors.

All of the Motion Controllers are based on a high performance digital signal processor (DSP), which enables a high control quality, precise positioning and very low speeds.

The following tasks can be performed:

- **Velocity control** with high requirements on synchronous operation and minimal torque fluctuations. A PI controller ensures observance of the target velocities.
- **Velocity profiles** such as ramp, triangular or trapezoidal movements can be realised. Gentle starting or deceleration can easily be implemented.
- **Positioning mode:** Starting from defined positions with high resolution (1/3000 revolutions using linear Hall sensors of BL motors).
- Acquisition of **reference marks and limit switches**.
- Extended operating modes: **Stepper motor mode, Analog positioning mode, Voltage regulator, Electronic gear**, operation with **external incremental encoder**. MCDC 3003/06 S: **IxR control**.
- **Torque control** via adjustable current limitation.
- **Storage** of the set configurations.
- **Storage and execution** of sequence programs.

Various inputs and outputs are available for the implementation of these tasks:

- **Set value input** for target velocity.  
Analog or PWM signals can be used. The input can also be used as digital or reference input. A frequency signal or an external incremental encoder can also be connected here.
- **Error output**(Open Collector).  
Can also be reprogrammed as rotational direction, digital or reference mark input, and as pulse or digital output.
- 1 to 3 additional **digital inputs**.

**RS232 interface** for connection to PC or control with transfer rates of up to 115 kBaud. An extensive set of ASCII commands is available for programming and operation. FAULHABER Motion Manager 3 software is available for Windows 95/98/ME/NT/2K/XP: this considerably simplifies operation and configuration of the units and also offers a graphic online analysis function for operating data.

The drive can also be operated independently of the RS232 interface if the desired function, such as velocity or position controller, has been previously programmed via analog input, stepper motor or electronic gear.

### **Fields of application**

Thanks to the compact design, the units can be integrated into diverse applications with minimal wiring. The flexible connection options open up a broad field of application in all areas, for example in decentralized automation technology systems, as well as in handling devices and machine tools.

### **Options**

A separate supply for motor and control electronics is optionally available ex works (important for safety-relevant applications), in which case the 3rd input is omitted. Special preconfiguration of modes and parameters is possible on request. The Motion Manager software can be downloaded free of charge from [www.faulhaber-group.com](http://www.faulhaber-group.com).

# 1 Overview

## 1.2 Quick start

To facilitate introduction, this chapter highlights the initial steps for commissioning and operation of FAULHABER Motion Controllers with serial interface.

However, the detailed documentation must always be read and adhered to, particularly chapter 2.5 **Basic Settings**.

The units are delivered as standard without a valid node address (NODEADRO) and with a transfer rate of 9600 baud. The settings can be changed via the interface, e.g. with the FAULHABER Motion Manager.

If the FAULHABER Motion Manager is to be used to change the connection parameters, proceed as follows:

1. Connect drive unit to a serial interface of the PC (e.g. COM1) via null modem cable and switch on.
2. Start FAULHABER Motion Manager.
3. Activate serial interface as communication interface and configure via the menu item "Terminal – Connections...".
4. Select menu item "Configuration – Connection parameters...".
5. Set desired transfer rate and node address.
6. Press "Send" button.
7. The settings are transferred to the controller. The Motion Manager then adjusts to the same baud rate and recalls the Scan function. The node should now be displayed with the correct node number in Node Explorer. After switching off and on again, the drive will operate with the set configuration.
8. If the settings are to be permanently stored, the "EEPSAV" button must then be pressed. After switching off and on again, the drive will operate with the set configuration.

### 1.2.1 Operation via FAULHABER Motion Manager

The FAULHABER Motion Manager offers easy access to the Motion Controller's command set. The desired node must have been activated beforehand by double clicking in Node Explorer in the case of network operation.

The FAULHABER commands described below can be entered directly in the command input line or selected from the Commands menu.

In order to drive a motor via the Motion Manager, follow the procedure below (assuming a matching baud rate):

1. Configure drive functions:

A user-friendly dialog that enables the desired settings to be made is available under the menu item "Configuration – Drive functions...".

**For external Motion Controllers MCBL 3003/06 S and MCDC 3003/06 S, you must check that the correct basic settings have been made for the connected motor (see chapter 2.5 Basic settings). For brushless motors, the correct motor type must be set, for DC motors the correct pulse number must be specified for the encoder (ENCRES) under "Drive parameters".**

For operating the drive via the PC, the set value pre-setting must be set to digital (SOR0). If the settings are to be permanently stored, press the "EEPSAV" button.

2. Activate drive:

"EN" command.

Enter in command input field and press "Send" button or select in "Commands – Motion control – Enable drive" menu and press "Send" button.

3. Operate motor (examples):

Drive motor with 100 rpm velocity control:

"V100" command. Enter in command input field and press "Send" button or select in "Commands – Motion control – Initiate velocity mode" menu, enter value 100 in dialogue box, press OK and "Send" button.

Stop motor:

"V0" command:

Move motor relatively by 10000 increments:

"LR10000" command to load the relative target position, "M" command to move to loaded target position.

# 1 Overview

## 1.2 Quick start

### 1.2.2 Operation via own host application

Set your host application to the controller transfer rate (default 9600 baud) with the following configuration:

- 8 data bits
- 1 stop bit
- No Parity

The Xon/Xoff protocol must be used for rapid command sequences or transfer of sequence programs and parameter sets.

An extensive set of ASCII commands is available for operating the FAULHABER Motion Controllers. The ASCII commands are structured as follows:

[Node no.]	Command	[Argument]	CR
------------	---------	------------	----

The node number is optional and is only required if several drives are being operated on one interface. The command consists of a letter character string. The optional argument consists of an ASCII numeric value. The end is always a CR character (Carriage Return, ASCII decimal code 13). Space characters are ignored, and no distinction is made between upper and lower case.

The response to query commands or asynchronous events is also an ASCII character string, followed by a CR character (Carriage Return, ASCII decimal code 13) and an LF character (Line Feed, ASCII decimal code 10).

Example:

Actual position queries:

Transmit: POS [CR]

Receive: 98956 [CR][LF]

Drive nodes at 500 rpm:

Transmit: V500 [CR]

If ANSW2 is set, you will receive an "OK" for pure transmit commands if the command has been successfully executed, or one of the following character strings:

"Unknown command"

"Invalid parameter"

"Command not available"

"Overtemperature – drive disabled"

Example:

Transmit: V500 [CR]

Receive: OK [CR][LF]

The EEPSAV command always responds with the character string "EEPROM writing done" after successful saving of the current settings in the data Flash memory, or with "Flash defect", if the save has failed. All commands are listed in Chapter 4 **Parameter Description**.

## 2 Installation

### 2.1 Connections and wiring

#### 1.) 3564K024B CS:

The connections are executed as coloured stranded wires and assigned as follows:

Wire	Designation	Meaning
Blue	GND	GND
Pink	+24V	+24 V
Brown	AnIn	Analog input
White	Fault	Error output
Grey	AGND	Analog GND
Yellow	RxD	RS232 RxD
Green	TxD	RS232 TxD
Red	3.In	3rd input/ optional electronics supply

#### 2.) MCBL 3003/06 S:

The connections are indicated on the terminal strips and are assigned as follows:

Supply side:	
Connect.	Meaning
TxD	RS232 TxD
RxD	RS232 RxD
AGND	Analog GND
Fault	Error output
AnIn	Analog input
+24V	+24 V
GND	GND
3.In	3rd input/optional electronics supply

Motor side:	
Connect.	Meaning
Ph A	Motor phase A (brown)
PH B	Motor phase B (orange)
Hall C	Hall sensor C (grey)
Hall B	Hall sensor B (blue)
SGND	GND signal (black)
+5V	VCC (red)
Hall A	Hall sensor A (green)
PH C	Motor phase C (yellow)

In addition, a 9-pin SUB-D connector is attached, with the following assignment:

Pin	Meaning
2	RxD
3	TxD
5	GND

#### 3.) MCDC 3003/06 S:

The connections are executed as terminal strips and are assigned as follows:

Supply side:	
Connect.	Meaning
TxD	RS232 TxD
RxD	RS232 RxD
AGND	Analog GND
Fault	Error output
AnIn	Analog input
+24V	+24 V
GND	GND
3.In	3rd input/optional electronics supply

Motor side:	
Connect.	Meaning
Mot -	Motor-
Mot+	Motor+
SGND	Encoder GND
+5V	Encoder VCC
Ch B	Encoder channel B
Ch A	Encoder channel A
4. In	4th input
5. In	5th input

In addition, a 9-pin SUB-D connector is attached, with the following assignment:

Pin	Meaning
2	RxD
3	TxD
5	GND



## 2 Installation

### 2.1 Connections and wiring

#### Power supply connections (+24 V, GND)

The power supply should be adequately dimensioned for the connected motor. Please pay attention to the polarity connection. An incorrect polarity connection will blow the internal fuse. This must be replaced in the factory!

#### Analog input (analog input, analog GND = AGND)

The analog input is executed as a differential input.

The analog GND should be connected to the power supply GND, in order to prevent a voltage drop in the supply cable from affecting the target velocity value.

The analog input has various uses, depending on the configuration:

- Presetting of target velocity value via analog voltage
- Presetting of target velocity value via PWM signal
- Current limitation value via analog voltage
- Presetting of target position via analog voltage
- Digital input for reference and limit switches
- Connection for an external encoder  
(Analog input to GND: Channel A / Analog GND to GND: Channel B) in gearing or BL encoder mode.

#### RS232 connections

The RS232 wiring is established via the connections RxD, TxD and the supply GND. The integrated RS232 interface allows direct connection with a PC with use of a null modem cable, in which the transmit cable (TxD) and the receive cable (RxD) are crossed.

#### Error output

The error output is characterised by the following characteristics:

- Switch that switches to GND (Open Collector)
- Output resistor in open state (High Level): 100 k $\Omega$
- The switch is open in the event of error (High Level)
- Output current limited to approx. 30 mA, voltage in open state must not exceed the power supply (maximum  $U_B$ )
- Short-circuit proof

The error output is activated in the following situations:

- Current limitation active
- Over-voltage controller active (power supply over 32 V)
- Power stage switched off due to over-temperature

The error output connection can also be reconfigured for other functions:

- Pulse output (only MCBL, 3564...B CS)
- Digital output
- Limit switch input
- Rotational direction input

#### 3rd input

This connection can be used as reference or digital input. The drive can also be optionally provided with separate electronics supply at this connection ex-works, enabling the motor voltage to be switched off independently of the electronics supply.

#### 4th/5th input (MCDC only)

These inputs can be used as digital inputs.

### 2.1.1 Installation instructions

The place of installation must be selected so that clean and dry cooling air is available for cooling the unit. The units are intended for indoor operation. Large amounts of dust and high concentrations of chemical pollutants must be avoided. Cooling of the unit must be guaranteed, especially when installing in housings and cabinets. As the unit operates with surface cooling, temperatures of up to 85 °C can occur. Perfect functioning is only guaranteed if the supply voltage lies within the defined tolerance ranges. Wiring work may only be carried out on terminal strips and connections if the units are voltage-free.

### 2.1.2 Maintenance

The units are maintenance-free in principle. The air filters of cabinet units must be regularly checked and cleaned if required, depending on the quantity of dust. In the event of heavy soiling, the units themselves must be cleaned with halogen-free agents.

### 2.1.3 Specialised staff

Only trained specialised staff and instructed persons with knowledge in the field of automation technology and standards and regulations such as **EMC Directive, Low Voltage Directive, Machinery Directive, VDE Regulations (such as DIN VDE 0100, DIN VDE 0113/EN 0204, DIN VDE 0160/EN 50178), Accident Prevention Regulations**

may install and commission the units. This description must be carefully read and heeded prior to commissioning.

## 2 Installation

### 2.2 RS232-Wiring

Use a null modem cable in which the transmit cable (TxD) and the receive cable (RxD) are crossed, in order to connect the controller with the PC or control.

#### Wiring with one Motion Controller – parameter NET0

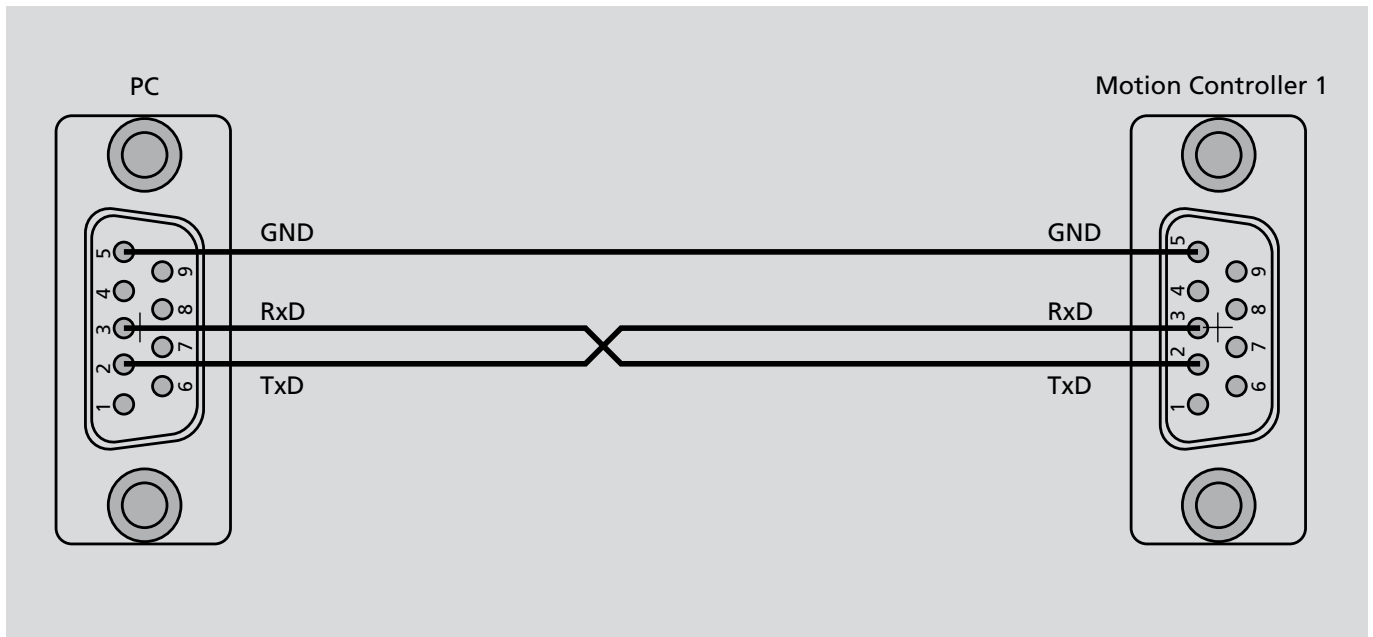

#### Wiring with more Motion Controllers – parameter NET1

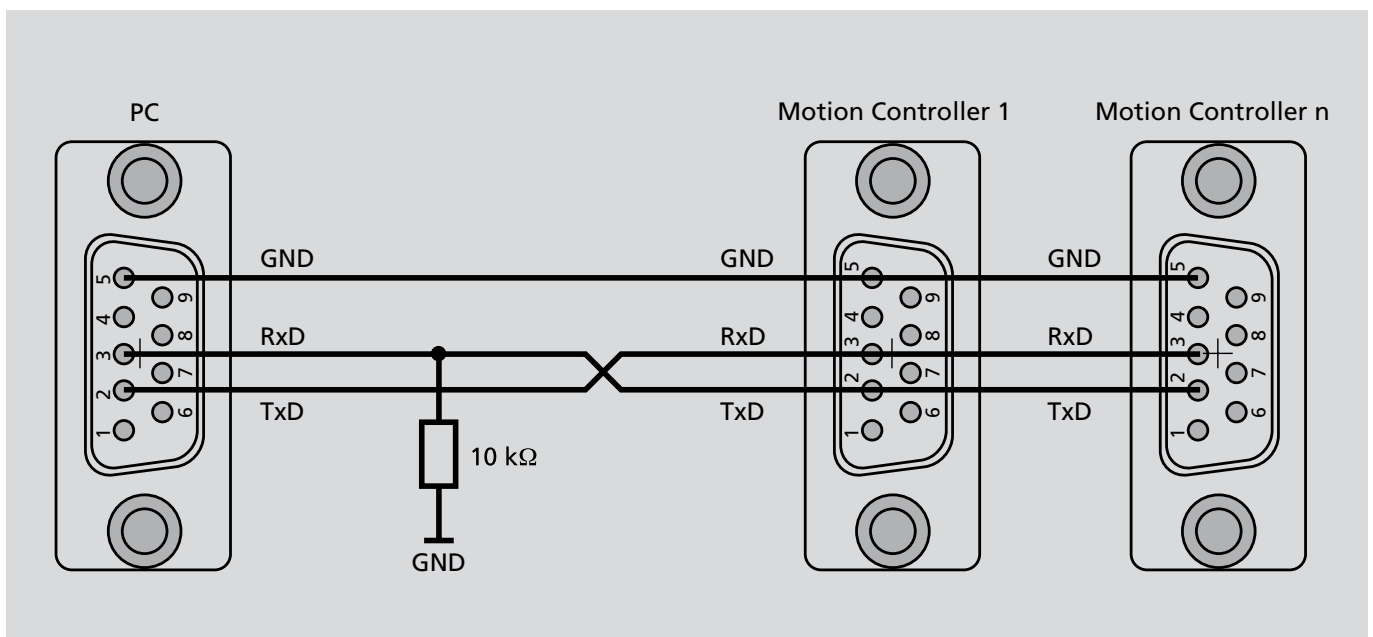

## 2 Installation

### 2.3 Motor connection

#### 1.) MCBL 3003/06 S:

The signal lines are susceptible to interference, therefore a maximum cable length can not be specified. For cable lengths > 300 mm the use of shielded wires is recommended.

#### MCBL connection

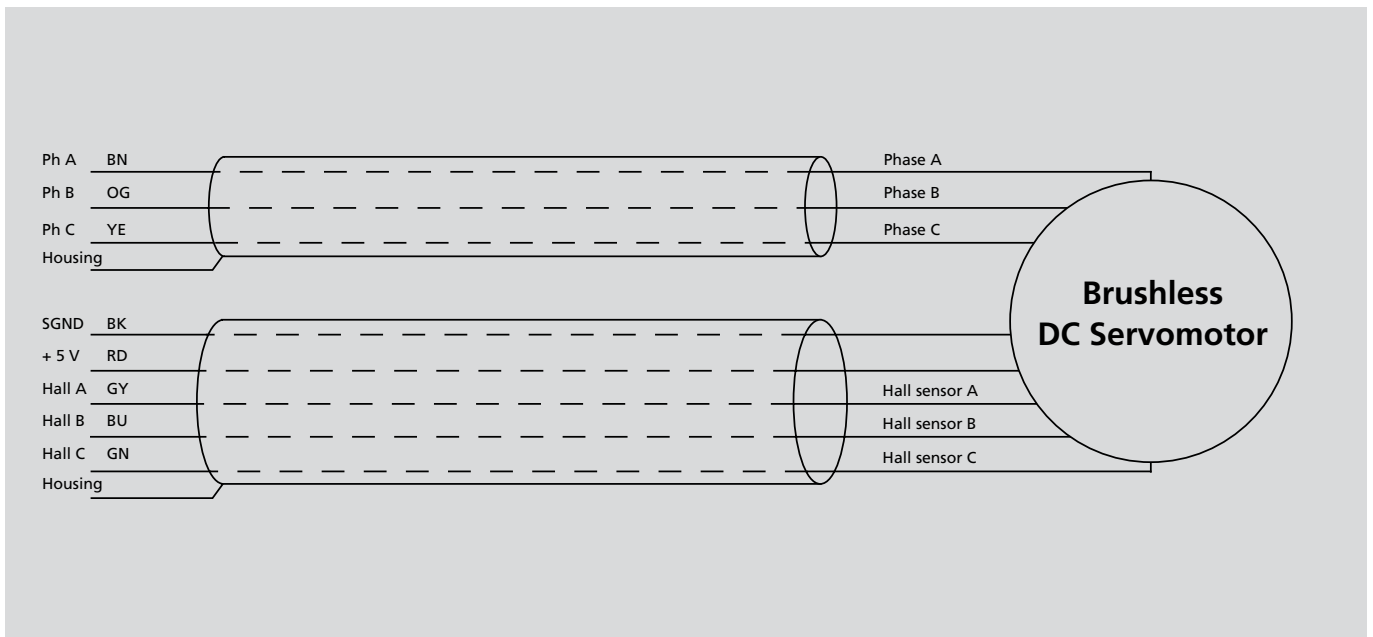

#### 2.) MCDC 3003/06 S:

The encoder lines are susceptible to interference, therefore a maximum cable length can not be specified. For cable lengths > 300 mm the use of shielded wires is recommended. When using an encoder with complementary outputs (e. g. line driver) please apply HEDL adapter board 6501.00064 from FAULHABER.

#### MCDC connection

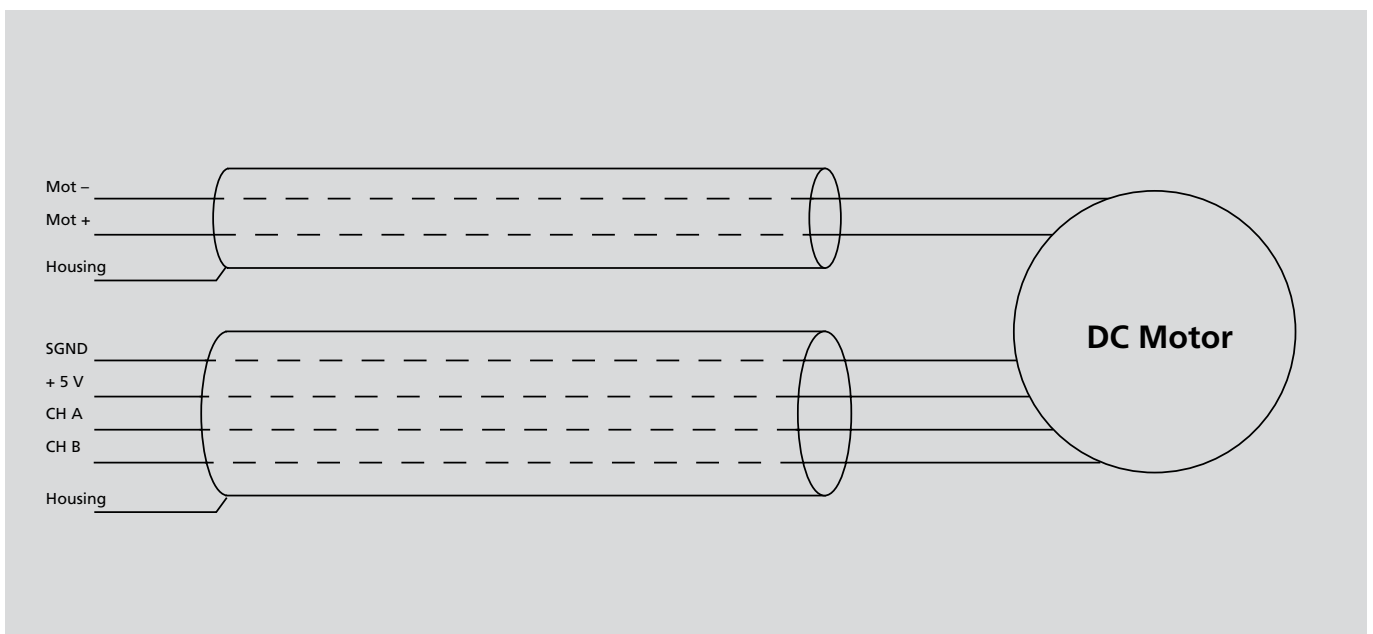

## 2 Installation

### 2.4 Baud rate and node number

The serial interface must be configured as follows:

- 8 data bits
- 1 stop bit
- No parity

The Xon/Xoff protocol must be used for rapid command sequences or transmission of sequence programs.

The following transfer rates can be set:

600 baud  
 1200 baud  
 2400 baud  
 4800 baud  
 9600 baud (default)  
 19200 baud  
 38400 baud  
 57600 baud  
 115200 baud

The setting can be changed via the interface if a connection already exists with the drive node:

Command	Function	Description
BAUD	Select baud	Preset transfer rate for RS232 interface

Example:

Change transfer rate to 19200 baud:  
 BAUD 19200

**Important:** If the baud rate of the controller has been changed, the baud rate of the PC and control must also be adjusted to the new baud rate to enable communication with the drive unit again.

If several drives are to be operated on a serial interface, each drive unit must have a unique node number between 1 and 255.

Command	Function	Description
NODEADR	Define Node Address	Set node number

Example:

Set drive unit to node number 3:  
 NODEADR3

All units are delivered with node number 0. In order to prepare the units for network operation, they must first be individually connected to the PC and set to the desired node address using the FAULHABER Motion Manager.

A serial network can be constructed using the so-called daisy-chain technique, in which the transmit cable of the Master (PC, PLC) is connected to the receive cable of the first node, from where it is looped through to the receive cable of the second node, and so on. The same procedure is followed with the receive cable of the Master, which is looped through to all transmit cables of the drive node. The current generation of Motion Controllers do not require a multiplexer board for serial network operation. Multiplex mode is activated with a new command:

Command	Function	Description
NET	Set Network Mode	Activate RS232 Multiplex mode for network operation. 1: Network operation activated 0: No network operation, single drive on an RS232

Example:

Activate network operation:  
 NET1

In order to address the individual drives in the network, the node number must be specified before each ASCII command to be sent (e.g. 3V100). Commands without a node number are adopted by all drive nodes in the network (Broadcast).

**Important:** No unaddressed query commands may be sent in network mode, as otherwise all units will answer simultaneously and the message frames will mix, resulting in communication errors.

It must also be ensured that no asynchronous responses are sent by several units simultaneously, and that the command acknowledgement is switched off when using unaddressed transmit commands.

Use the ANSW command to set the response behaviour:

Command	Function	Description
ANSW	Answer Mode	0: No asynchronous responses 1: Permit asynchronous responses 2: All commands with confirmation and asynchronous responses

Example:

Switch off asynchronous responses and command confirmation:  
 ANSW0

## 2 Installation

### 2.5 Basic settings

During initial commissioning of external Motion Controllers, a number of basic settings must be made in order to adjust the controller to the connected motor. Use the FAULHABER Motion Manager for easy execution of these adjustments.

**Failure to observe these basic settings can result in destruction of components!**

At delivery, the MCBL 3003/06 S is set to motor type 5 (2444S024B K1155) as standard. If you wish to connect another motor, you must set the correct motor type first of all. The FAULHABER Motion Manager then enables the Hall sensor signals to be synchronised for smooth starting and the phase angle to be optimised for best efficiency. This process should also be carried out whenever the motor is replaced and during initial commissioning (“Optimisation to connected motor” in the “Configuration – Drive functions” menu).

The controller parameters and current limitation values must also be adapted to the connected motor and the application.

The MOTTYP command adjusts the controller to the relevant motor. Internal parameters are also changed for the specified values:

The values set with the MOTTYP command can be individually changed later. With the RN command, the default parameters are set according to the set motor type. If you wish to connect a motor that is not specified in the motor type list, select motor type 0 (MOTTYP0) and set the parameters  $k_n$  (velocity constant) and  $R_m$  (ferrule resistor) in accordance with the specifications in the data sheet using the commands KN and RM.

The MCDC 3003/06 S is set to an encoder resolution of 512 pulses (ENCRES 2048) as standard at delivery. 4 times the encoder resolution is entered (quadrature signal processing) via the ENCRES command or the Drive Parameters dialogue in the Motion Manager (“Configuration – Drive functions” menu).

The parameters  $R_m$  and  $k_n$  must be set to protect the power stage of the MCDC 3003/06 S during braking operation. The values are indicated in the datasheet of the connected motor. In addition, the controller parameters and the current limitation values must be adapted to the connected motor and application.

If using the Fault Pin as input (REFIN, DIRIN), the desired function must be programmed before applying external voltage!

MOTTYP	Motor type	P-term (POR)	I-term (I)	PP	PD	li	Peak current (mA)	Continuous current (mA)
1	1628T012B K1155	12	25	24	2	40	3000	770
2	1628T024B K1155	12	22	8	10	40	3000	410
3	2036U012B K1155	6	45	10	14	50	3000	980
4	2036U024B K1155	14	25	17	6	50	3000	480
5	2444S024B K1155	7	40	16	9	50	5000	1370
6	3056K012B K1155	8	30	22	13	50	7000	1940
7	3056K024B K1155	10	40	22	12	50	3000	930
8	3564K024B K1155	8	40	12	6	50	8000	2800
9	4490H024B K1155	8	40	12	6	20	10000	6000

### 3 Functional Description

The Motion Controllers can be configured for different operating modes.

As standard the drive unit is delivered as a servomotor with set value presetting via the serial interface. The drive can be reconfigured by means of the corresponding FAULHABER commands.

If the settings are to be permanently stored, the command SAVE (EEPSAV) must be executed after the configuration; this saves the current settings in the Flash data memory, from where they are reloaded when the unit is next switched on. The prerequisite for operation of the drive in one of the operating modes specified here is that the power stage is activated (EN).

All commands and objects listed below are summarised and explained in the **Parameter Description** chapter.

The FAULHABER Motion Manager 3 enables simple setting of the configuration parameters and operating modes via corresponding dialogue windows. The specified commands can be entered in plain text or selected from the Commands menu.

**Circuit example:**

**3564K024B CS with reference switch at analog input**

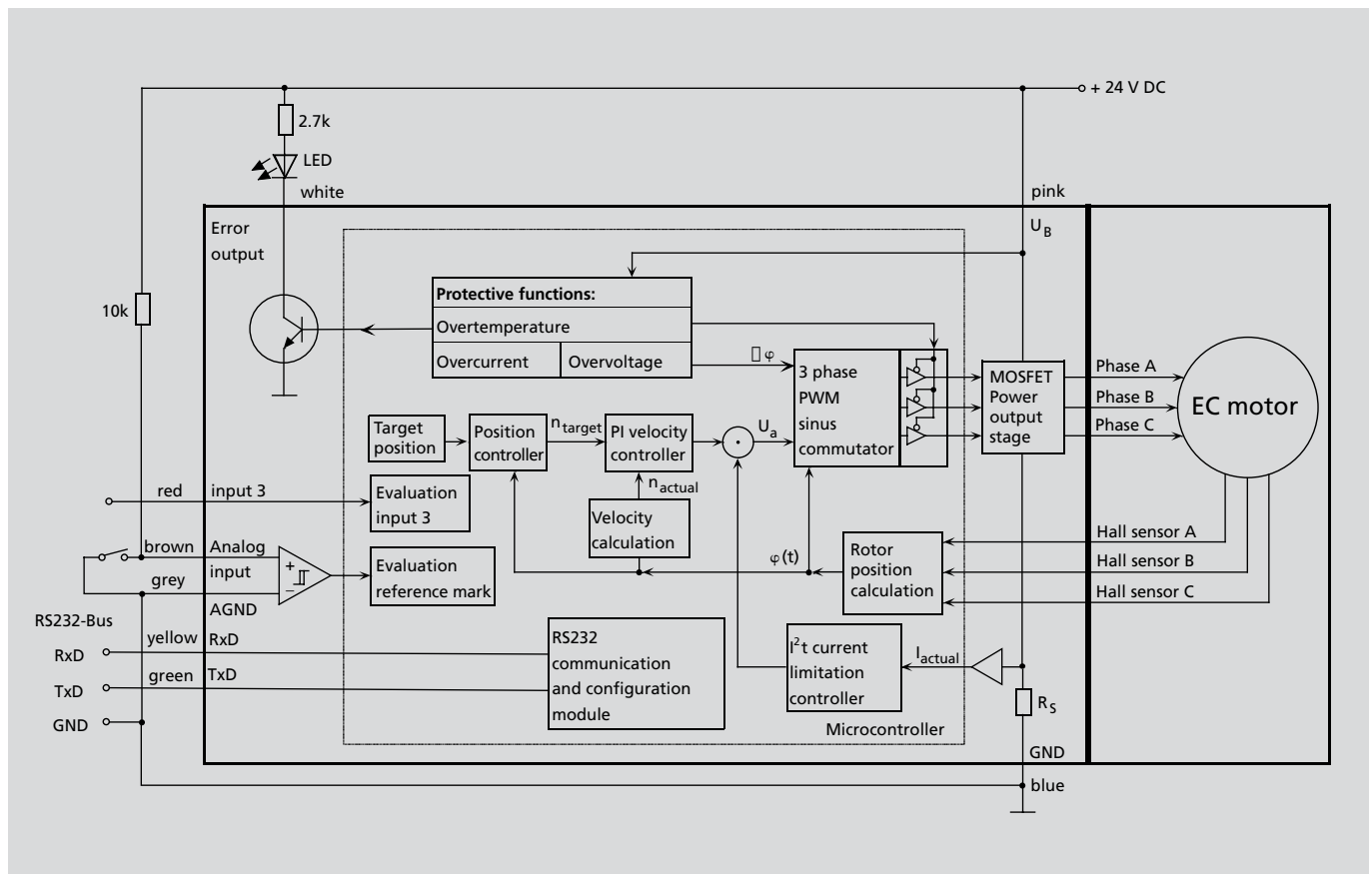

## 3 Functional Description

### 3.1 Position control

In this operating mode, target positions can be preset via the serial interface: FAULHABER operating mode CONTMOD or ENCMOD and SOR0 are set.

Profile and controller parameters are executed via the FAULHABER basic setting commands (**General Parameters**). In particular the acceleration values AC and DEC, the maximum speed SP, the current limitation values LPC and LCC, as well as the controller parameters POR, I, PP and PD must be adapted to the respective application. The positioning range limits can be set via the command LL and activated via APL. The positioning is executed via the FAULHABER motion control commands:

Command	Function	Description
LA	Load Absolute Position	Load new absolute target position Value range: $-1.8 \cdot 10^9 \dots 1.8 \cdot 10^9$
LR	Load Relative Position	Load new relative target position, in relation to last started target position. The resulting absolute target position must lie between $-2.14 \cdot 10^9$ und $2.14 \cdot 10^9$ .
M	Initiate Motion	Activate position control and start positioning

Example:

- 1.) Load target position: LA40000
- 2.) Start positioning: M

Attainment of the target position or any intermediate position is indicated by a "p" if "Notify Position" is set before the start of positioning, provided that ANSW1 or ANSW2 is set:

Command	Function	Description
NP	Notify Position	Without argument: A "p" is returned when the target position is attained.  With argument: A "p" is returned when the specified position is over-travelled.
NPOFF	Notify Position Off	A Notify Position command that has not yet been triggered is deactivated again.

If the linear Hall sensors of the brushless motors are used as position transducers (3564K024B CS, MCBL 3003/06 S), 3000 pulses per revolution are supplied. The COMPATIBLE1 command can be used to switch to 1000 pulses per revolution, in order to retain compatibility with the predecessor models (3564K024B C, MCBL 2805).

In COMPATIBLE1 mode, when the AC value is changed the DEC value is also set to the same value, and the positioning range limits divided by 3, additional the parameter SR will be changed from 1 to 18 (1,8 ms scanning rate from MC.. 2805). Independent for them, the user can readjust SR.

In the case of APL0, relative positionings can also be executed beyond the range limits. If the upper (1800000000) or lower limit ( $-1800000000$ ) is exceeded, counting is continued at 0 without loss of increments.

#### Complex motion profiles

Complicated motion profiles can be generated through skilful presetting of new values (maximum speed, acceleration, end position) during positioning. After a value change, simply execute a new motion start command (M). The commands NP and NV can be used to control the sequence.

Example:

Sequence (respective command sequences after receipt of the Notify condition):

Start:	a.)	b.)	c.)	d.)
LA[POS3]	AC[AC2]	AC[AC1]	SP[SP2]	DEC[DEC4]
AC[AC1]	NV[V2]	NP[POS1]	DEC[DEC3]	NP[POS3]
SP[SP1]	M	M	NP[POS2]	M
NV[V1]			M	
M				

The following diagram shows the described sequence.

Example of complex motion profile in comparison with trapezoidal profile:

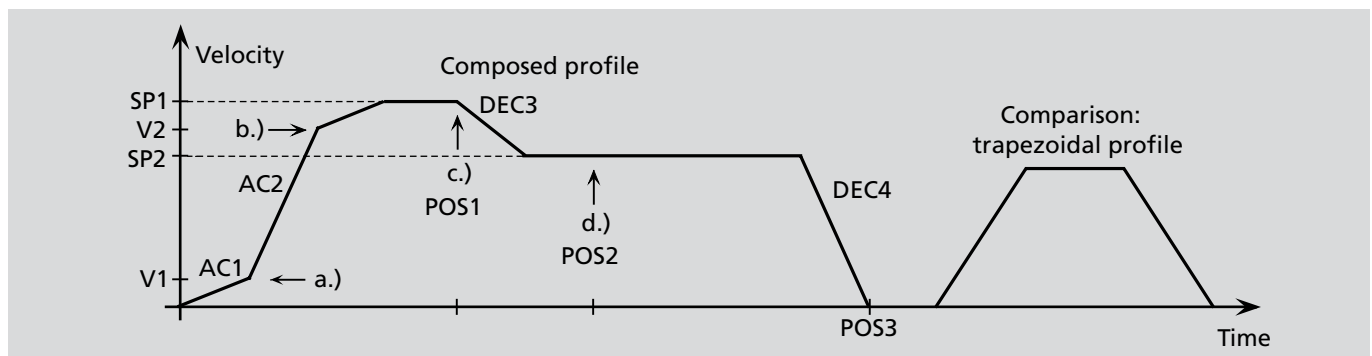

## 3 Functional Description

### 3.2 Velocity control

#### 3.2.1 Velocity presetting via RS232

In this operating mode, the drive velocity can be controlled with set value presetting via RS232:

Setting: CONTMOD or ENCMOD and SOR0 operating mode

Profile and controller parameters are set with the FAULHABER basic setting commands (**General Parameters**).

In particular the acceleration values AC and DEC, the current limitation values LPC and LCC, as well as the controller parameters POR and I, must be adapted to the respective application.

The velocity control is executed with the following FAULHABER motion control command:

Command	Function	Description
V	Select Velocity Mode	Activate velocity mode and set specified value as target velocity (velocity control) Unit: rpm

Example:

Drive motor at 100 rpm: V100

In order to change the direction of rotation, simply assign a negative velocity value (e.g. V-100). V0 will stop the drive.

Make sure that APL0 is set, if you do not want the drive to stop at the set range limits (LL)! Also check that the maximum speed SP is not set below the desired target velocity.

Reaching the nominal speed is indicated by a "v", if "Notify Velocity" has been set before starting the speed mode and ANSW1 or ANSW2 is set:

Command	Function	Description
NV	Notify Velocity	A "v" is returned when the nominal speed is reached. Value range: -32767...32767
NVOFF	Notify Velocity Off	An untriggered Notify Velocity command will be deactivated again

Example:

When a speed of 1000 rpm is reached or passed, a "v" is sent: NV1000



## 3 Functional Descriptions

### 3.2 Velocity control

#### 3.2.2 Analog velocity presetting

Setting: CONTMOD and SOR0 operating mode (velocity presetting via voltage at analog input) or SOR2 (velocity presetting via PWM signal at analog input).

Profile and controller parameters are executed via the FAULHABER basic setting commands (General Parameters). In particular, the acceleration values AC and DEC, the current limitation values LPC and LCC, as well as controller parameters POR and I, must be adapted to the respective application. The analog velocity control can be further configured using the parameters described below:

##### Setting the scaling factor (maximum speed):

Target velocity at 10 V.

Command	Function	Description
SP	Load Maximum Speed	Load maximum speed. Setting applies for all modes (except VOLTMOD) Unit: rpm

Example:

Set maximum speed so that with 10 V at the analog input the target velocity is 5000 rpm: SP5000.

##### Setting the minimum velocity:

Minimum velocity that is preset when the start voltage is present.

Command	Function	Description
MV	Minimum Velocity	Presetting of minimum velocity in rpm

Example:

Set minimum velocity to 10 rpm: MV10

##### Setting the start voltage:

Voltage from which the drive is to start.

Command	Function	Description
MAV	Minimum Analog Voltage	Presetting of minimum start voltage in mV

Example:

The drive is only to start moving with voltages over 100 mV or below -100 mV at the analog input: MAV 100

Advantage:

As 0 mV is usually difficult to set at the analog input, 0 rpm is also not easy to implement. The dead band produced by the minimum start voltage prevents the motor from starting as a result of small interference voltages.

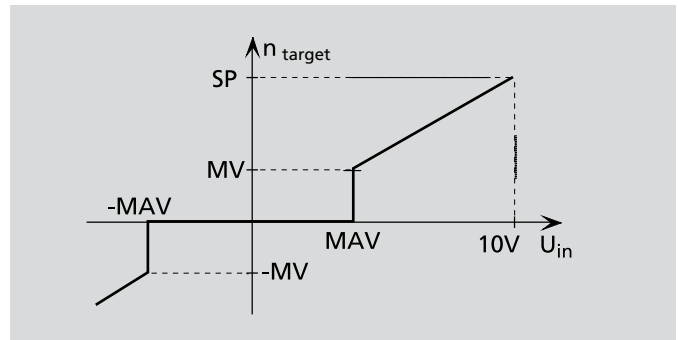

##### Setting the direction of rotation:

Command	Function	Description
ADL	Analog Direction Left	Positive voltages at the analog input result in anticlockwise rotation of the rotor
ADR	Analog Direction Right	Positive voltages at the analog input result in clockwise rotation of the rotor

Example:

Clockwise rotation in the case of positive voltages: ADR

The error output (fault pin) can also be reconfigured as a digital rotational direction input:

Command	Function	Description
DIRIN	Direction Input	Use fault pin as rotational direction input

Level and direction:

Low: ... Left-hand rotation  
(corresponding to ADL command)

High: ... Right-hand rotation  
(corresponding to ADR command)

The level at the rotational direction input is dominant to the settings made with ADR and ADL. ADR and ADL are thus ineffective.

### 3 Functional Description

#### 3.2 Velocity control

##### Set-point presetting via pulse width signal (PWM) at the analog input (SOR2):

At delivery:

- Pulse duty factor >50% → Clockwise rotation
- Pulse duty factor =50% → Stationary
- Pulse duty factor <50% → Anticlockwise rotation

The commands SP, MV, MAV, ADL and ADR can also be used here.

Make sure that APL0 is set, if you do not want the drive to stop at the set range limits (LL)!

##### Note on input circuit:

The input circuit at the analog input is designed as a differential amplifier. If the analog input is open, an undefined velocity can be set. The input must be connected to AGND with low-impedance and set to the voltage level of the AGND, in order to generate 0 rpm.

##### Simple set-point presetting via potentiometer, circuit example with 3564K024B CS:

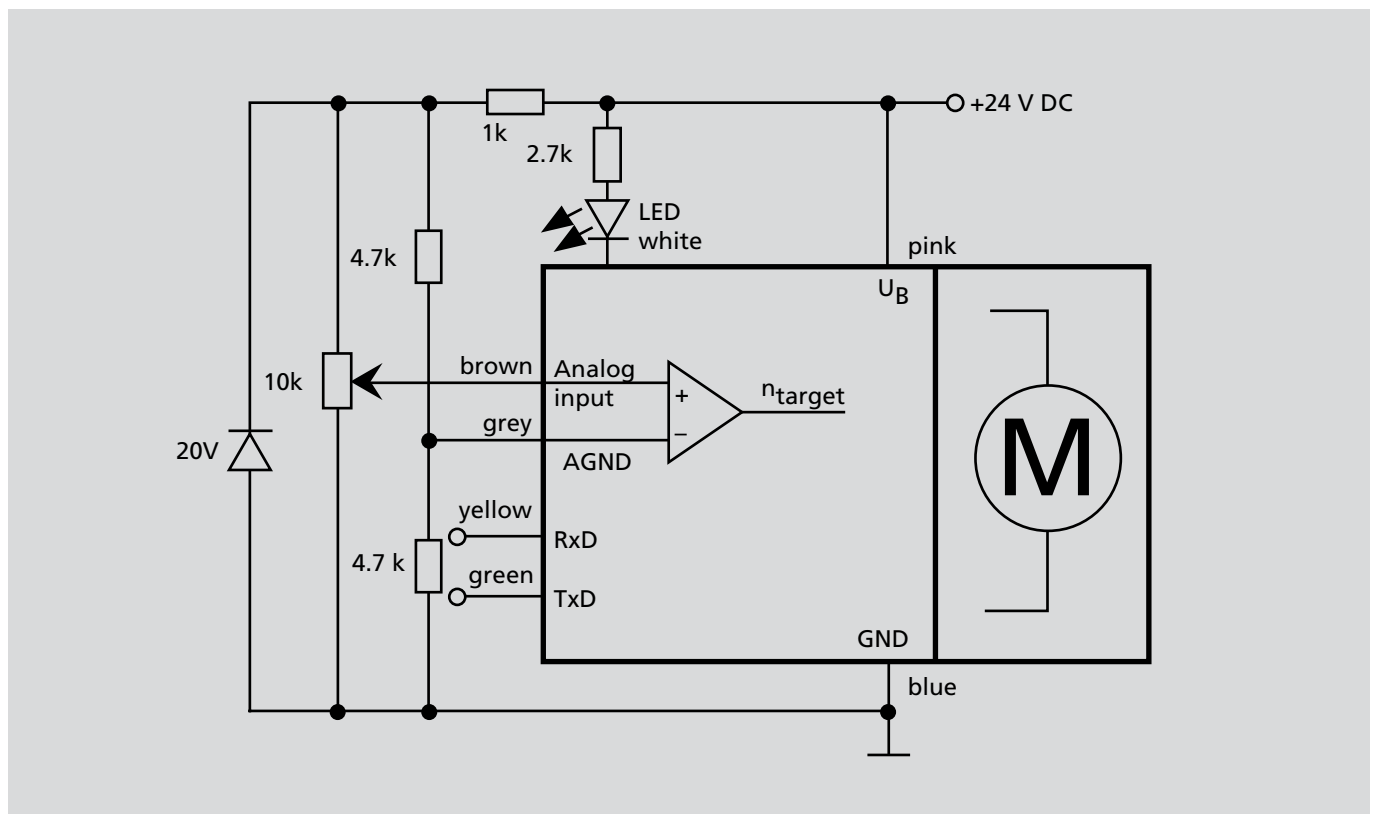

## 3 Functional Description

### 3.3 Homing and limit switches

The connections

- AnIn
- Fault
- 3., 4., 5. In, if present

can be used as reference and limit switch inputs.

In BL motors the zero crossing of the Hall sensor signals is also available as index pulse, occurring once per revolution. The index pulse of an external encoder can also be connected to the fault pin, enabling the actual position to be exactly zeroed.

The AnIn and Fault connections are designed as interrupt inputs, which means that they are edge-triggered. All other inputs are not edge-triggered, so that the signal must be at least 500 µs to be reliably detected. The maximum reaction time to level changes at all inputs is 500 µs.

#### Set levels of digital inputs:

Command	Function	Description
SETPLC	Set PLC-Inputs	Digital inputs PLC-compatible (24 V level)
SETTTL	Set TTL-Inputs	Digital inputs TTL-compatible (5 V level)

The signal level of the digital inputs can be set using the above commands:

PLC (Default): Low: 0...7.0 V / High: 12.5 V...U<sub>B</sub>

TTL: Low: 0...0.5 V / High: 3.5 V...U<sub>B</sub>

#### Configure fault pin as reference or limit switch input:

Command	Function	Description
REFIN	Reference Input	Fault pin as reference or limit switch input

The limit switch functions for the fault pin are only accepted if REFIN is activated (setting must be saved with SAVE or EEPSAV)!

**Important:** Configure the fault pin as input before applying external voltage!

The function of the inputs and the homing behaviour is set with the FAULHABER commands described below. A previously configured homing is then started with the following FAULHABER commands:

Command	Function	Description
GOHOSEQ	Go Homing Sequence	Execute FAULHABER homing sequence. A homing sequence is executed (if programmed) irrespective of the current mode.
GOHIX	Go Hall Index	Move BL motor to Hall zero point (Hall index) and set actual position value to 0 (not with MCDC)
GOIX	Go Encoder Index	Move to the encoder index at the Fault pin and set actual position value to 0 (DC motor or ext. encoder).
POHOSEQ	Power-On Homing Sequence	Start homing automatically after switch-on. 1: Power-On homing sequence activated 0: No homing after switch-on

## 3 Functional Description

### 3.3 Homing and limit switches

#### Configuration of homing and limit switches:

The following commands use the following bit mask for configuration of the limit switch functions:

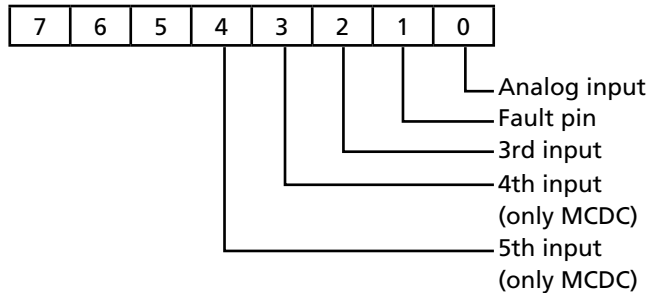

Set or delete the bit at the position of the required input for each command and assign the resulting numeric value to the commands described below.

#### Polarity and limit switch function:

Command	Function	Description
HP	Hard Polarity	Define effective edge and polarity of respective limit switches: 1: Rising edge and high level effective. 0: Falling edge and low level effective.
HB	Hard Blocking	Activate Hard-Blocking function for relevant limit switch.
HD	Hard Direction	Presetting of direction of rotation which is blocked by HB of the respective limit switch. 1: Clockwise rotation blocked 0: Anticlockwise rotation blocked

The Hard-Blocking function provides reliable protection against overshooting of the range limit switch. If the drive is located in an HB limit switch, then the direction of rotation set with HD will be blocked, i.e. the drive can only move further out of the limit switch. The speed stays at 0 rpm if target velocities are preset in the wrong direction.

Example:

Setting of the Hard-Blocking function for Fault pin and 4th input:

$$2^1 + 2^3 = 2 + 8 = 10 \rightarrow \text{HB10}$$

#### Definition of homing behaviour:

Command	Function	Description
SHA	Set Home Arming for Homing Sequence	Homing behaviour (GOHOSEQ): Set position value to 0 at edge of respective limit switch.
SHL	Set Hard Limit for Homing Sequence	Homing behaviour (GOHOSEQ): Stop motor at edge of respective limit switch.
SHN	Set Hard Notify for Homing Sequence	Homing behaviour (GOHOSEQ): Send a character to RS232 at edge of respective limit switch.

In order to be able to execute a homing sequence with the command GOHOSEQ, a homing sequence must be defined for a specific limit switch!

If the drive is already located in the limit switch when GOHOSEQ is invoked, first of all it moves out of the switch, in the opposite direction to that specified for HOSP.

Example:

Homing with 3rd input as reference input (rising edge):

HP4  
SHA4  
SHL4  
SHN4

Alternatively, the homing sequence can also be set with the command CAHOSEQ in conjunction with the commands HA, HL and HN.

#### Homing Speed:

Command	Function	Description
HOSP	Load Homing Speed	Load speed and direction of rotation for homing (GOHOSEQ, GOHIX). Unit: rpm

Example: HOSP-100

## 3 Functional Description

### 3.3 Homing and limit switches

#### Direct programming via HA, HL and HN commands:

Command	Function	Description
HA	Home Arming	Set the position value to 0 and delete corresponding HA bit at edge of respective limit switch. Setting is not saved.
HL	Hard Limit	Stop motor and delete corresponding HL bit at edge of respective limit switch. Setting is not saved.
HN	Hard Notify	Send character to RS232 and delete corresponding HN bit at edge of respective limit switch. Setting is not saved.

These special commands can be used to define actions that are to be triggered at an edge of the relevant input, independently of a homing sequence. A programmed limit switch function will remain effective until the preselected edge occurs. The programming can be changed with a new command before an edge occurs. The settings are not saved with the SAVE command, so all limit switches are inactive again after switch-on.

#### HL/SHL command:

**Positioning mode:** When the edge occurs, the motor positions itself on the reference mark with maximum acceleration.

**Velocity controller mode:** The motor is decelerated at the set acceleration value when the edge occurs, i.e. it goes beyond the reference mark. The reference mark can be precisely approached with a subsequent positioning command (command M).

**Advantage:** No abrupt motion changes.

## 3 Functional Description

### 3.4 Extended operating modes

Use the CONTMOD command to revert from an extended operating mode to normal mode.

#### 3.4.1 Stepper motor mode

Command	Function	Description
STEPMOD	Stepper Motor Mode	Change to stepper motor mode

In stepper motor mode, the analog input acts as frequency input. The error output must be configured as rotational direction input if the direction of rotation is to be changed via a digital signal. Alternatively, the direction of rotation can also be preset via the commands ADL and ADR.

Command	Function	Description
DIRIN	Direction Input	Fault pin as rotational direction input

The drive moves one programmable angle further for each pulse at the analog input, and thus simulates the function of a stepper motor.

There are a number of considerable advantages in comparison with a real stepper motor:

- The number of steps per revolution is freely programmable and of a very high resolution (encoder resolution)
- The individual step widths are freely programmable
- No detent torque
- The full dynamics of the motor can be used
- The motor is very quiet
- Because of the absolute encoder, there is no step loss (even with maximum dynamics)
- No motor current flows in settled state (actual position reached)
- High efficiency
- The control electronics are already integrated in the 3564K024B CS

Input:

Maximum input frequency: 400 kHz

Level: 5 V TTL or 24 V PLC-compatible, depending on configuration.

Stepper motor mode enables position-accurate velocity control; any rational ratios can be set for input frequency to motor speed, via step width and step number, in accordance with the following formula:

$$\text{Revolutions} = \text{pulses} \cdot \frac{STW}{STN}$$

Revolutions	...Revolutions that are generated on the drive
Pulses	...Number of pulses at the frequency input (=number of steps)
STW	...Step width (step width factor = number of steps per encoder pulse at the frequency input)
STN	...Step number (number of steps = number of steps per revolution)

Value range of STN and STW: 0 to 65535

Command	Function	Description
STW	Load Step Width	Load step width for step motor and gearing mode
STN	Load Step Number	Load number of steps per revolution for step motor and gearing mode

Example:

Motor should turn 1/1000th of a revolution for each input pulse:

STW1

STN1000

The acceleration and speed values (AC, DEC, SP) are also taken into account in step motor mode. These permit gentle starting and deceleration. The position range limits set via LL can also be activated with the APL1 command.

#### 3.4.2 Gearing mode (electronic gear)

Gearing mode enables the use of an external encoder as set-point source for the position.

Command	Function	Description
GEARMOD	Gearing Mode	Change to gearing mode

The two channels of an external encoder are connected to connections AnIn and AGND, which may need to be connected to the 5 V encoder supply via a 2.7 kΩ pull-up resistor.

The gear ratio can be set in accordance with the following formula:

$$\text{Revolutions} = \text{pulses} \cdot \frac{STW}{STN}$$

Revolutions	...Revolutions that are generated on the drive
Impulse	...Actually counted pulses resulting from a four-edge evaluation
STW	...Step width (step width factor = number of steps per encoder pulse)
STN	...Step number (number of steps = number of steps per revolution)

### 3 Functional Description

#### 3.4 Extendend operating modes

Value range of STN and STW: 0 to 65535

Command	Function	Description
STW	Load Step Width	Load step width for stepper motor and gearing mode
STN	Load Step Number	Load number of steps per revolution for stepper motor and gearing mode

Example: Motor has to move one revolution at 1000 pulses of the external encoder:  
STW1, STN1000

The direction of rotation can be predefined with the commands ADL and ADR, or via an external signal at the fault pin (DIRIN command).

The acceleration and speed values (AC, DEC, SP) are also taken into account in gearing mode. These permit gentle starting and deceleration. The position range limits set via LL can also be activated with the APL1 command.

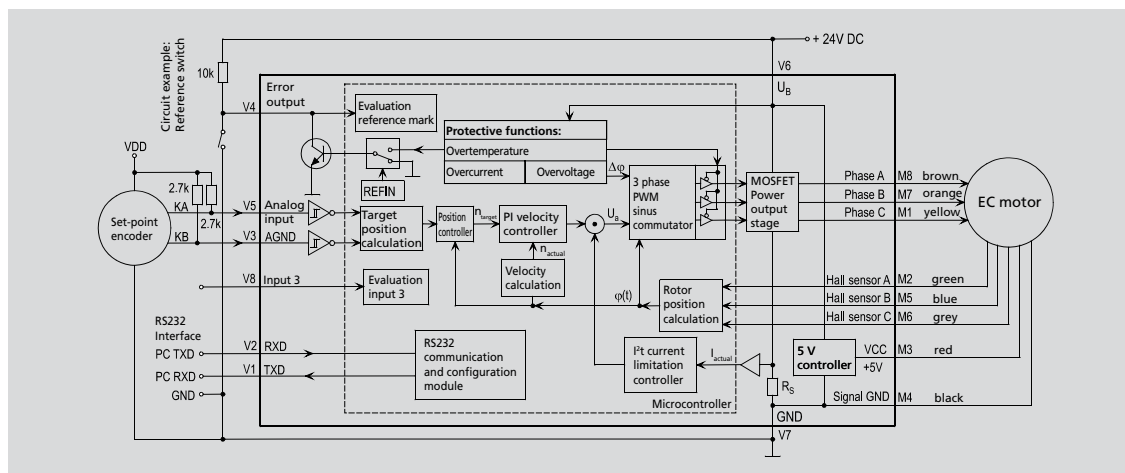

**Circuit example gearing mode for MCBL 3003/06 S**

#### 3.4.3 Analog positioning mode

In analog positioning mode, the position set-point can be preset via a potentiometer or an external analog voltage.

Command	Function	Description
APCMOD	Analog Position Control Mode	Change to position control via analog voltage

The maximum position to be approached with a voltage of 10 V can be preselected with the LL command. With a voltage of -10 V, the drive moves in the opposite direction.

Command	Function	Description
LL	Load Position Range Limits	Load limit positions (the drive does not move out of these limits in positioning mode, positive values specify the upper limit and negative values specify the lower limit). APCMOD: Position value at 10 V

Irrespective of the preset LL value, the maximum position is limited to 3 000 000 (COMPATIBLE1 = 1 000 000) in APCMOD. Note: The resolution of the analog input is limited to 12 bit (4096 steps).

The direction of rotation can be predefined with the commands ADL and ADR. The acceleration and speed values (AC, DEC, SP) are also taken into account in APCMOD. These permit gentle starting and deceleration.

#### Positioning via pulse width signal (PWM) at the analog input (SOR2):

If SOR2 is set in APCMOD, the pulse duty factor of a PWM signal can be used as position set-point.

At delivery:

- Pulse duty factor >50% → positive target position
- Pulse duty factor =50% → target position = 0
- Pulse duty factor <50% → negative target position

#### Absolute positioning within one revolution:

Thanks to the linear Hall sensors, the absolute position can be recorded within one revolution on BL motors. This means that even if the power supply is disconnected, the position determination supplies the correct position value after restarting (if the rotor has only been turned within one revolution).

The following commands enable the drive to be accurately positioned in the voltage range 0 V to 10 V within one revolution and to return to the correct position even after the supply has been switched off, without homing (not MDCD):

- APCMOD ...change to analog positioning
- LL3000 ...fix maximum position at 1 revolution (COMPATIBLE1: LL1000)

## 3 Functional Description

### 3.4 Extended operating modes

#### 3.4.4 External encoder as absolute encoder (not MCDC)

For high-precision applications, the actual values of BL motors can be derived from an external encoder.

- The resolution of the position values is dependent on the resolution of the encoder in this case.
- Depending on the application, the velocity can be derived from the encoder or from the Hall sensors.
- The external encoder can be mounted directly on the motor shaft, but an encoder that is mounted to the application output (e.g. glass scale) is particularly advantageous. This allows the high precision to be set directly at the output.
- Commutation still occurs via the analog Hall sensors.

Command	Function	Description
ENCMOD	Encoder Mode	Change to encoder mode (not for MCDC) External encoder serves as position transducer (the current position value is set to 0)
HALLSPEED	Hall sensor as speed sensor	Speed via Hall sensors in encoder mode (not for MCDC)
ENCSPPEED	Encoder as speed sensor	Speed via encoder in encoder mode (not for MCDC)

The two channels of the external encoder are connected to connections AnIn and AGND, which may need to be connected to the 5 V encoder supply via a 2.7 kΩ pull-up resistor.

The maximum limit position (value preset with the LL command) covers the value range from 0 to 1800000000 for the positive and 0 to -1800000000 for the negative limit position.

Input:

Maximum input frequency: 400 kHz

Level: low 0...0.5 V / high 3.5 V... U<sub>B</sub>

Set encoder resolution:

Command	Function	Description
ENCRES	Load Encoder Resolution	Load resolution of external encoder. Value range: 0 to 65535 (4 times pulse/rev)

Example:

External encoder with 512 pulses: ENCRES2048

Because of the quadrature signal processing, four times the number of pulses must always be specified for ENCRES.

#### 3.4.5 Voltage regulator mode

If the drive is to operate as a pure voltage regulator, this can be configured with VOLTMOD. The motor voltage is then output proportionally to the default value. The current limitation remains active. With this mode, it is possible to use a higher level regulator. The controller then serves only as a power amplifier.

Command	Function	Description
VOLTMOD	Set Voltage Mode	Activate Voltage Regulator Mode
U	Set Output Voltage	Output motor voltage. Value: -32767 ...32767 (corresponds to -U <sub>v</sub> ..+U <sub>v</sub> ) only for SOR0

Three options exist to control the output voltage: Interface, analog input voltage, and PWM.

**Using interface requires first setting SOR0.**

The command U sets the output voltage proportional to the supply voltage. A value of 32767 passes the full power supply voltage to the motor. A value of 0 passes 0 V to the motor. A value of -32767 passes the full power supply voltage inverted.

**Using an analog voltage requires first setting SOR1.**

The input analog voltage will scale the output voltage to the motor. A value of 10 V passes the full power supply voltage to the motor. A value of 0 V passes 0 V to the motor. A value of -10 V passes the full power supply voltage inverted.

**Using a PWM signal requires first setting SOR2.**

A 100 % duty cycle passes the full power supply voltage to the motor. A 50 % duty cycle passes 0 V to the motor. A 0 % duty cycle passes the full power supply voltage inverted.



## 3 Functional Description

### 3.4 Extended operating modes

#### 3.4.6 Analog target current presetting

You can switch to analog target current presetting with the SOR3 command. The limitation current is then proportional to the voltage at the analog input, and the internal  $I_{\text{pt}}$  current limitation is deactivated. The set current is weighted with the maximum current LPC. If 10 V are present at the analog input, the current is accordingly limited to the maximum current set with LPC. Even if negative voltages are present at the analog input, the current is limited to the amount of the applied voltage. Negative target current presettings therefore have no effect on the direction of rotation!

#### 3.4.7 IxR control for DC controllers

For speed-controlled applications with DC motors without an encoder, an IxR control is available on the MCDC. In this mode, the motor speed is determined via an internal motor model. Consequently, the encoder and the associated wiring can be omitted. However, control quality and accuracy are considerably restricted. This mode is mainly suited for higher speeds and larger motors in the FAULHABER range.

Command	Function	Description
IXRMOD	Set IxR Mode	Activate IxR control (only for MCDC)
RM	Load Motor Resistance	Load motor resistance $R_M$ according to specification in data sheet. Unit: mOhm
KN	Load Speed Constant	Load speed constant $k_n$ according to specifications in data sheet. Unit: rpm/V

## 3 Functional Description

### 3.5 Special functions of the error connection

The error connection (fault pin) can be configured as input or output for different tasks:

Command	Function	Description
ERROUT	Error Output	Fault pin as error output
ENCOUT	Encoder Output	Fault pin as pulse output (not MCDC)
DIGOUT	Digital Output	Fault pin as digital output. The output is set to low level.
DIRIN	Direction Input	Fault pin as rotational direction input
REFIN	Reference Input	Fault pin as reference or limit switch input

The REFIN and DIRIN functions have already been explained in the relevant chapters.

#### Fault pin as error output:

In ERROUT mode the output is set as soon as one of the following errors occurs:

- One of the set current limitation values (LPC, LCC) is exceeded
- Set maximum permissible speed deviation (DEV) is exceeded
- Overvoltage detected
- Maximum coil or MOSFET temperature exceeded

In order to hide the transient occurrence of errors during the acceleration phase, for example, an error delay can be set which specifies how long an error must be present before it is displayed at the error output:

Command	Function	Description
DCE	Delayed Current Error	Delayed error output for ERROUT in 1/100 sec.

Example:

Only display error after 2 seconds: DCE200

If one of the above errors occurs, automatic notification with an "r" can be implemented by setting "Notify Error", provided that ANSW1 or ANSW2 is set:

Command	Argument	Function	Description
NE	0-1	Notify Error	Error notification: 1: An "r" is sent back if an error occurs 0: No error notification

#### Fault pin as pulse output (not for MCDC):

In the ENCOUT mode the fault pin is used as pulse output, which outputs an adjustable number of pulses per revolution. The pulses are derived from the Hall sensor signals of the BL motors and are limited to 4000 pulses per second.

Command	Function	Description
LPN	Load Pulse Number	Preset pulse number for ENCOUT. Value range: 1 to 255

Example:

Output 16 pulses per revolution at the fault pin: LPN16  
In the case of 5000 rpm,  $5000/60 \cdot 16 = 1333$  pulses per second are output.

For speeds that would generate more than the maximum possible pulse number at the set LPN value, the maximum number is output. The set pulses are precisely achieved, but the timing does not necessarily have to exactly agree (delays possible). Position determination via pulse counting is therefore possible, provided that no change occurs in the direction of rotation and the maximum possible pulse number is not exceeded.

#### Fault pin as digital output:

In DIGOUT mode, the error connection can be used as universal digital output. The digital output can be set or deleted via the following commands.

Command	Function	Description
CO	Clear Output	Set digital output DIGOUT to low level
SO	Set Output	Set digital output DIGOUT to high level
TO	Toggle Output	Switch digital output DIGOUT

## 3 Functional Descriptions

### 3.6 Sequence programs

Sequence programs that are stored directly in the data flash memory of the controller and executed from there can be created for stand-alone applications or for partially autonomous sequences.

The sequence programs can be created and transferred with the FAULHABER Motion Manager, but it is also possible to use a standard text editor and to subsequently transfer the programs with the Motion Manager or a terminal program.

During a program sequence commands can still be sent via the RS232. Almost all ASCII commands can be used in motion programs.

The command PROGSEQ can also be used in the network with a preceding node number. The subsequent command must be send also with a preceding node number. The addressed node stores all received instructions thereby, between the commands PROGSEQ and END.

#### Control of sequence programs:

There are a number of additional commands for controlling programs which are only useful within sequence programs and are consequently only available there.

The following commands stop the sequence until the relevant position is reached:

NP ...Notify Position

The sequence stops at the next M command, until the relevant position is reached.

HN ...Hard Notify

The sequence stops at the GOHOSEQ command or at the next M or V command, until the limit switch is overtravelled.

NV ...Notify Velocity

The sequence stops at the next M or V command, until the relevant speed is reached.

GOHIX ...Go Hall Index

The sequence stops at the GOHIX command, until the Hall null position is reached.

If there are several Notify conditions, the first fulfilled condition effects continuation of the program.

The following commands are available for sequence programs:

Command	Argument	Function	Description
PROGSEQ [...] END	-	Program Sequence	Defines the start and end of the sequence program. All commands sent to PROGSEQ are not executed, but transferred to the sequence program memory. An END marks the end of the sequence program. All commands after END are directly executed again. There is no SAVE command necessary for saving the programm sequence. Attention: Command must not be executed more than 10,000 times, as otherwise the function of the Flash memory can no longer be guaranteed. These commands do not have to be entered in the FAULHABER Motion Manager, as they are automatically attached by the "Transfer program file..." function.
GPROGSEQ	-	Get Program Sequence	Reads out and sends back the stored program sequence. Each program line is output in lower case letters, ending with a CR character. At the end of the program the line "end:" is sent, with specification of the program length in bytes followed by a CR and LF character.
ENPROG	-	Enable Program	Execution of the program is released, i.e. the sequence is started. This status can be permanently stored with SAVE/EEPSAV, so that the drive starts up with the stored program sequence immediately after switch-on.
DIPROG	-	Disable Program	Deactivate program execution.
RESUME	-	Resume	Continue program sequence after DIPROG at the point at which it was interrupted.
MEM	-	Memory	Send back available program memory in bytes.

## 3 Functional Description

### 3.6 Sequence programs

Additional commands for use within sequence programs:

Command	Argument	Function	Description
DELAY	Value	Delay	Stop sequence for a defined period Argument: in 1/100 seconds Value range: 0 to 65535
TIMEOUT	Value	Timeout	In the case of Notify commands, only wait for the preset time and then continue the sequence again. Send a "o" to RS232 if Notify condition was not fulfilled. Argument: in 1/100 seconds Value range: 0 to 65535 (can also be used via RS232).
JMP	Address	Jump	Jump to the specified address (can also be used via RS232).
JMPGx	Address	Jump if greater than x	Jump to the specified address if result of last query command is greater than variable x (A, B, C).
JMPLx	Address	Jump if less than x	Jump to the specified address if result of last query command is less than variable x (A, B, C).
JMPEx	Address	Jump if equal x	Jump to specified address if result of last query command is equal to variable x (A, B, C).
JPH	Address	Jump if Hard-Input activated	Jump to the specified address if the analog input is active (HP determines the polarity).
JPF	Address	Jump if Fault-Input activated	Jump to the specified address if the Fault Pin input is active (HP determines the polarity). Fault Pin must be configured as input (REFIN).
JPT	Address	Jump if 3. Input activated	Jump to the specified address if the 3rd input is active (HP determines the polarity).
JPD (only MCDC)	Address	Jump if 4. Input activated	Jump to the specified address if the 4th input is active (HP determines the polarity).
JPE (only MCDC)	Address	Jump if 5. Input activated	Jump to the specified address if the 5th input is active (HP determines the polarity).
SETx	Value	Set Variable x	Set variable x (A, B, C) to the specified value. Value range: Int32 Without argument: Result of last query command is loaded into the variable.
GETx	-	Get Variable x	Query content of variable x (A, B, C).
DxJNZ	Address	Decrement x, Jump if not Zero	Decrease the value of variable x (A, B, C) by one and jump to specified address if the value is not 0.
ERI	Address	Error Interrupt	An error interrupt is activated from execution of this command. This means that if an error subsequently occurs (overvoltage, current limitation...), then the sequence branches to the specified address. The error handling mode is ended if a JMP or RETI command is executed.
RETI	-	Return Error Interrupt	Return from an error handling routine. Important: the interrupted command is not continued, even if it was not completed at the time of interruption!
DIERI	-	Disable Error Interrupt	The ERI command is deactivated, i.e. in the event of an error the program does not jump to the error handling routine.
CALL	Address	Call Subroutine	Call a subroutine at specified address.
RET	-	Return from Subroutine	Return from a subroutine. Please note that only one subroutine level is possible, i.e. no subroutines can be called within subroutines!
A	Address	Define Address	Definition of current position as entry address for jump commands.

## 3 Functional Descriptions

### 3.6 Sequence programs

Explanations of the commands and functions:

#### Jump commands

The program sequence can be specifically controlled with the jump commands.

The **JMP** command can also be used from the RS232. This is useful in cases where different program routines are to be called from the computer.

#### Example:

```
A1
JMP1    ... Endless loop
A2      ... Program sequence 2
        (can only be called by JMP2 from the RS232)

LA10000
NP
M
JMP1    ... Return to endless loop
A3      ... Program sequence 3
        (can only be called by JMP3 from the RS232)

LA-10000
NP
M
JMP1    ... Return to endless loop
```

The program sequences according to A2 or A3 can only be called by a JMP2 or JMP3 command from the RS232. A JMP2 from the RS232 results in the drive moving to position 10000 and stopping there.

The **DxJNZ** commands serve to form loops with a predefined number of cycles.

#### Example:

```
Move by the same relative position 5 times.
SETA5   ... Set variable A to the value 5
A2      ... Define jump address 2
LR100   ... Load relative position
NP      ... Notify position
M       ... Start positioning
DAJNZ2  ... Decrease A by 1 and jump to address 2,
        provided that variable A is not yet 0.
```

The commands **JPH**, **JPF** and **JPT** enable jumps that are only executed if the relevant input is active. This means that programs can be called via external switches.

The commands **JMPGx**, **JMPLx**, **JMPEx** enable jumps that refer to the result of the last query command.

#### Example:

```
SETA 100
GN
JMPLA3
```

The command JMPLA3 jumps to address 3 if the velocity value returned with GN is less than 100 rpm (value of variable A).

Entry addresses are defined via command **A**. In the case of a jump, the sequence is continued at this point.

The value range for jump commands extends from 0 to 255. Accordingly, a maximum of 256 different entry points can be defined with JMP, JPx, ERI and CALL.

#### Error Interrupt

During execution of the ERI command, nothing happens initially. Only if an error situation subsequently occurs does the sequence jump immediately to the specified address. This enables sensible continuation of the program in the event of error.

The RETI command enables you to return to the position at which the sequence was interrupted. Please note that the interrupted command is no longer executed, but is continued with the next command.

No new error interruption can take place within the error handling routine. The error handling status is cancelled as soon as the RETI or JMP command is executed. After this, the commands are interrupted again if an error occurs. It should therefore be ensured that the error situation disappears in the error handling routine. Otherwise, the error handling call will be repeated.

#### Homing

The HN/SHN command enables you to stop the sequence until the limit switch is reached. In order to correctly execute the GOHOSEQ command within a sequence, it is essential to set the SHN command accordingly when defining the homing sequence. This is necessary particularly if you wish to use the Power-On Homing sequence (POHOSEQ1).

#### Notify commands

Notify commands enable you to generate complicated motion profiles.

## 3 Functional Description

### 3.6 Sequence programs

#### Example:

```
LA100000
SP5000
AC50
NV1000
M
AC100
NV2000
M
AC50
NP
M
```

With this sequence, the acceleration is increased during boot-up at 1000 rpm. It is decreased again at 2000 rpm.

Note: The NP command without argument stops the sequence until the target position is reached.

#### The CALL command

The CALL command enables subroutines to be called from different points, any number of times. You can only jump back from a subroutine again with the RET command. All commands are permitted within a subroutine except for a repeated CALL command.

#### General

If a sequence program is completely processed (no jump at the end of a program), then an "n" is sent to the RS232, if ANSW1 or ANSW2 is set.

In order to generate an endless program (useful for stand-alone operation), a jump command is required at the end of the program.

#### Memory size

The sequence programs are stored in binary coding in the Flash memory; 2 bytes are stored for each command, and 0 to 4 bytes for the argument. The maximum storage size available for sequence programs is 6656 bytes (3328 words).

#### Examples:

##### 1.) Positioning routines called via RS232

The program enables the calling of different routines from the RS232 interface:

- JMP2: Homing Sequence. First move to a limit switch and then to the Hall sensor zero point (Hall index), in order to obtain the most precise reference point possible.
- JMP3: Move to position 0 and stop there.

- JMP4: Attempt to approach a position with low current limitation. As there may be an obstacle in the way in the application, the target position may not be attained. The motor should be stopped after 5 seconds, in any event. (Further evaluation occurs in the higher level control).

- JMP5: 1000 cycles with following sequence: 10 revolutions forwards, 1 second pause, 5 revolutions back again and then 0.5 seconds pause.

#### Configuration

- SOR0 → Digital velocity presetting via RS232
- LR0 → No motion
- M → Switch to position control (Motion 0)
- SHA1 → Homing Sequence with Notify at AnIn
- SHN1
- SHL1
- HOSP200 → Homing speed 200 rpm
- HP1 → Rising edge at limit switch effective
- ENPROG → Start motion program after power-on
- ANSW0 → No asynchronous responses
- EEPSAV → Save configuration

#### Program

- A1
- JMP1 → Endless loop
- A2 → Entry point for homing sequence (JMP2)
- GOHOSEQ → Homing to reference switch
- GOHIX → Subsequent homing to Hall sensor zero point (Hall index)
- JMP1 → Return to endless loop
- A3 → Entry point for routine 1 (JMP3)
- LA0 → Set target position to 0
- NP → Notify at target position (sequence stops until target position is reached)
- M → Start positioning
- JMP1 → Return to endless loop
- A4 → Entry point for routine 2 (JMP4)
- LPC500 → Set current limitation values to 500 mA (continuous current ≤ peak current)
- LA1000000
- NP
- TIMEOUT500 → Continue sequence after 5 sec., even if position has not yet been attained
- M → Start positioning
- V0 → Stop motor
- LR0

## 3 Functional Descriptions

### 3.6 Sequence programs

M	→ Switch back to positioning mode
JMP1	→ Return to endless loop
A5	→ Entry point for routine 3 (JMP5)
SETA1000	→ Predefine variable A
A6	→ Entry point for loop
LR30000	
NP	
M	
DELAY100	
LR-15000	
NP	
M	
DELAY50	
DAJNZ6	→ Repeat loop 1000 times
JMP1	→ Return to endless loop

#### Comment:

The individual routines are called from the serial interface by sending the commands "JMP2", "JMP3", etc..

If the sequence is to wait until the end of a motion command (M, GOHOSEQ, etc.), a Notify (NP or SHN1 in the Homing Sequence configuration) must be set first of all.

#### 2.) Sequence controlled via digital input (without RS232)

- After power-on, the drive moves to the limit switch and then the Hall index.
- With a positive edge at the fault pin digital input, the drive moves forward 5000 increments.
- If the level is still high after 5000 increments, the drive moves to position 0.

#### Configuration

SOR0	→ Digital velocity presetting via RS232
LR0	→ No motion
M	→ Switch to position control (Motion 0)
REFIN	→ Reprogram error output to input
SHA1	→ Homing Sequence with Notify at AnIn
SHN1	
SHL1	
HOSP-200	→ Homing velocity 200 rpm backwards
HP1	→ Rising edge at limit switch effective
POHOSEQ1	→ Execute Homing Sequence after power-on
ENPROG	→ Start motion program after power-on
ANSW0	→ No asynchronous responses
EEPSAV	→ Save configuration

#### Program

GOHOSEQ	→ Homing to reference switch
GOHIX	→ Subsequent homing to Hall sensor zero point (Hall index)
A1	
HP3	→ High level at input 2 (Fault pin input) effective
A2	
JPF2	→ Endless loop until low level at input 2
HP1	→ Low level at input 2 (Fault pin input) effective
A3	
JPF3	→ Endless loop until high level at input 2 (evaluation of positive edge)
LR5000	
NP	
M	→ Move forward 5000 increments
DELAY50	→ Wait 0.5 seconds until input 2 is queried
JPF1	→ Jump back to start in case of low level at input 2
LA0	
NP	
M	→ Move to position 0, if high level at input 22
JMP1	→ Jump to start

#### Comment:

With this program, an RS232 interface is no longer required for operation (stand-alone application).

The desired sequence is started with short pulses at the input (e.g. key) and the return is triggered with a continuous signal (e.g. switch).

## 3 Functional Description

### 3.7 Trace function

An efficient trace function is available via an additional binary interface. This allows up to 2 values to be read out online in a resolution of up to 3 ms.

In order to be able to use the binary interface, it must first have been opened for the desired node with the command BINSEND1.

Command	Argument	Function	Description
BINSEND	0 – 1	Open Binary Interface	1 = Open binary interface 0 = Close binary interface

#### Trace configuration:

1. Setting of binary transmit mode for parameter 1 (curve 1):

2 binary characters are sent in direct succession:

[Command][Mode1]

The relevant value is switched to, depending on the value of Mode1.

Command:

200: Set binary transmit mode for parameter 1

Mode 1:

- 0: Current velocity [Integer16, rpm]
- 1: Target velocity [Integer16, rpm]
- 2: Controller output [Integer16]
- 4: Motor current [Integer16, mA]
- 44: Housing temperature [Unsigned16, °C]
- 46: Coil temperature [Unsigned16, °C]
- 200: Current position [Integer32, Inc]
- 201: Target position [Integer32, Inc]

2. Setting of binary transmit mode for parameter 2 (curve 2):

2 binary characters are sent in direct succession:

[Command][Mode2]

The relevant value is switched to, depending on the value of Mode2.

Command:

202: Set binary transmit mode for parameter 2

Mode 2:

- 0: Current velocity [Integer16, rpm]
- 1: Target velocity [Integer16, rpm]
- 2: Controller output [Integer16]
- 4: Motor current [Integer16, mA]
- 44: Housing temperature [Unsigned16, °C]
- 46: Coil temperature [Unsigned16, °C]
- 200: Current position [Integer32, Inc]
- 201: Target position [Integer32, Inc]
- 255: No second parameter is sent (basic setting at power-on)

#### Data request:

A binary character is sent: [Request]

Depending on the set modes (Commands 200 and 202), 3,5,7 or 9 bytes are sent back to the PC.

Request:

201: Request for a data packet

After setting a mode you must wait at least 2 ms before requesting valid data.

Received data (after request 201):

1.) Mode1 between 0 and 15,  
Mode2 at 255 (inactive)

→ 3 byte...      1st byte: Low byte data  
                         2nd byte: High byte data  
                         3rd byte: Time code

The data are in Integer16 format.

2.) Mode1 between 16 and 199,  
Mode2 at 255 (inactive)

→ 3 byte ...    Coding as in 1.)

The data are in Unsigned16 format.

3.) Mode1 between 200 and 255,  
Mode2 at 255 (inactive)

→ 5 byte ...    1st byte: Lowest byte data  
                         2nd byte: Second byte data  
                         3rd byte: Third byte data  
                         4th byte: Highest byte data  
                         5th byte: Time code

The data are in Integer32 format.

4.) Mode1 corresponding to 1.), 2.) or 3.) and  
Mode2 less than 255:

→ 5 to 8 byte ... Byte 1 to 2 (4):  
                         Data bytes of Mode1  
                         Byte 3 (5) to 4 (6) (8):  
                         Data bytes of Mode2  
                         Byte 5 (7): Time code

The data bytes of Mode2 are coded as for Mode1.

The time code corresponds to a multiple of the time basis of 1 ms and defines the time interval to the last transmission. In Compatibility Mode (COMPATIBLE1), the time basis is 9 ms.



## 3 Functional Description

### 3.8 Technical information

#### 3.8.1 Sinus commutation

The 3564K024B CS and the MCBL 3003/06 S are characterised by a so-called sinus commutation. This means that the preset rotating field is always ideally positioned in relation to the rotor. As a result, torque fluctuations can be reduced to a minimum, even at very low speeds. In addition, the motor runs particularly quietly.

In the current version, the sinus commutation has been extended by a so-called flat-top modulation, which enables 15 % more modulation. As a result, higher no-load speeds are possible. With the SIN0 command, the system can even be set so that over 30 % more modulation is possible. In this mode, the sinus commutation in the upper speed range switches over to a block commutation. This full modulation enables the complete speed range of the motor to be utilised.

Command	Function	Description
SIN	Sinus Commutation	0: Full modulation 1: Limitation to sinus form

#### 3.8.2 Current controller and I<sup>2</sup>t current limitation

The FAULHABER Motion Controllers are equipped with an integral current controller, which enables implementation of a moment limitation.

The following parameters can be set:

Command	Function	Description
LPC	Load Peak Current Limit	Load peak current Value range: 0 to 12000 mA
LCC	Load Continuous Current Limit	Load continuous current Value range: 0 to 12000 mA
CI	Load Current Integral Term	Load integral term for current controller Value range: 1...255

##### 1.) Peak current

FAULHABER command:

LPC8000 → set peak current to 8000 mA

The current is limited to the peak current, provided that the thermal current model calculates a non-critical temperature.

##### 2.) Continuous current

FAULHABER command:

LCC2800 → set continuous current to 2800 mA

If the thermal current model reaches a critical temperature, continuous current is switched to.

##### Mode of operation of the current controller:

When the motor starts, the peak current is preset as the set-point for the current controller. As the load increases, the current in the motor constantly increases until it finally

reaches the peak current. The current controller then comes into operation and limits the current to this set-point.

A thermal current model operating in parallel calculates a model temperature from the actually flowing current. If this model temperature exceeds a critical value, continuous current is switched to and the motor current is regulated to this. Only when the load becomes so small that the temperature falls below the critical model temperature is peak current permitted again.

The aim of this so-called I<sup>2</sup>t current limitation is to prevent heating of the motor beyond the thermally permissible temperature through appropriate selection of the continuous current. On the other hand, a high load should be temporarily possible in order to enable very dynamic movements.

##### Functioning of the I<sup>2</sup>t current limitation:

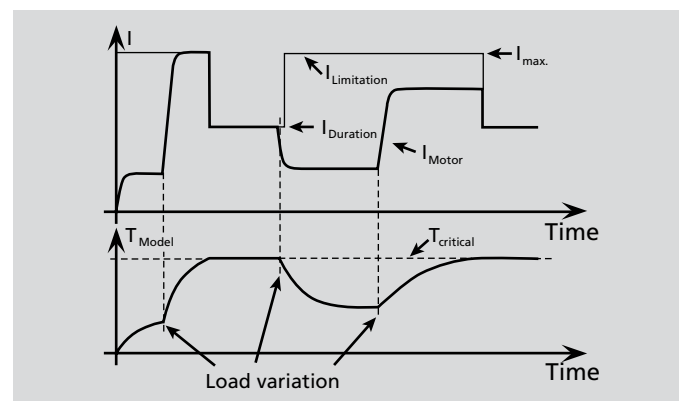

#### 3.8.3 Overtemperature protection

If the MOSFET temperature of the external controllers or the coil temperature of the 3564K024B CS exceeds a preset limit value, the motor is switched off. The following conditions must be fulfilled in order to reactivate the motor:

- Temperature below a preset limit value
- Target velocity set to 0 rpm
- Actual motor speed less than 50 rpm

##### Note on determination of the coil temperature:

The housing temperature is measured and the power loss concluded from the current measurement. The MOSFET or coil temperature is calculated from these values via a thermal model. In most applications, this method represents a thermal motor protection device.

## 3 Functional Description

### 3.8 Technical information

#### 3.8.4 Undervoltage monitoring

If the supply voltage falls below the lower voltage threshold, the power stage is switched off. The Motion Controller remains active. When the voltage returns within the permissible range, the power stage is switched on again immediately.

#### 3.8.5 Overvoltage regulation

If the motor is operated as a generator, it produces energy. Usually power supply units are not able to feed this energy back into the power line. Consequently, the supply voltage at the motor increases, and depending on the speed, the permissible maximum voltage may be exceeded.

In order to avoid severe damage to components, the 3564K024B CS and the MCBL 3003/06 S contain a controller which adjusts the rotor displacement angle if a limit voltage (32 V) is exceeded. The MDCD 3003/06 S contains a ballast circuit which is activated if a limit voltage (32 V) is exceeded. As a result, the energy generated in the motor is converted, and the voltage of the electronics remains limited to 32 V. This method protects the drive during generating operation and rapid braking.

#### 3.8.6 Adjustment of the controller parameters

The controller parameters are already preset for common applications. However, in order to optimally adapt the controller to the respective application, the controller parameters must be optimized. Various theoretical and practical adjustment rules exist, but these will not be described in more detail here. A simple, practical method of adjusting the controller is explained below.

The digital controller operates at a sampling rate of 100  $\mu$ s. When needed the sampling rate can be increased up to 2 ms via the command SR.

The following controller parameters are available:

Command	Function	Description
POR	Load Velocity Proportional Term	Load velocity controller amplification. Value range: 1 – 255.
I	Load Velocity Integral Term	Load velocity controller integral term. Value range: 1 – 255.
PP	Load Position Proportional Term	Load position controller amplification. Value range: 1 – 255.
PD	Load Position D-Term	Load position controller D-term. Value range: 1 – 255.
SR	Load Sampling Rate	Load sampling rate of the velocity controller as a multiplier of 100 $\mu$ s. Value Range: 1...20 ms/10

#### Possible procedure:

a.) Set parameters of velocity controller:

- 1.) First of all you have to choose the right sampling rate for the velocity controller depending on the encoder resolution. With less encoder pulses you need a lower sampling rate (i.e. ENCRES256 -> SR18). For BL motors with internal encoder (3000 pulses) the maximum sampling rate SR1 (100  $\mu$ s) is recommended.

Set initial configuration:

- Controller amplification = 8; POR8
- Integral term = 20; I20
- Speed at 1/3 of the maximum application speed (example V1000)
- Set acceleration to highest value of the application (example AC10000)

- 2.) Increase controller amplification (step width 5, less subsequently); POR 13
- 3.) Preset velocity jump from 1/3 of maximum speed to 2/3 (example V2000)
- 4.) Velocity jump from 2/3 to 1/3 and monitor behaviour (example V1000)
- 5.) Repeat steps 2 to 4, until the controller becomes unstable. Then reduce controller amplification until stability is reliably ensured.
- 6.) Follow steps 2 to 5 with integral term.

b.) Set parameters of position controller:

- 1.) Set initial configuration
  - Default value for P term: 8; PP8
  - Default value for D term: 15; PD15
- 2.) Motion profiles appropriate for the application must now be run. If the system does not function stably with these settings, stability can be achieved by reducing the I term of the velocity controller or reducing the P term of the position controller.
- 3.) The P term of the position controller can now be increased until the system becomes unstable, in order to optimise the motion profile.
- 4.) The stability can then be restored through the following measures:
  - Increasing the D term of the position controller (example: PD20)
  - Reducing the I term of the velocity controller

## 4 Parameter Description

All ASCII commands that are available for operation of the FAULHABER Motion Controllers are listed below.

The ASCII commands have the following structure:

[Node no.]	Command	[Argument]	CR
------------	---------	------------	----

The node number is optional and is only required if several drives are being operated on one interface.

The command consists of a letter character string.

The optional argument consists of an ASCII numeric value.

The end is always a CR character (Carriage Return, ASCII decimal code 13). Space characters are ignored, and no distinction is made between upper and lower case.

The response to query commands or asynchronous events is also an ASCII character string, followed by a CR character (Carriage Return, ASCII decimal code 13) and an LF character (Line Feed, ASCII decimal code 10).

**Example:**

Actual position queries:

Transmit: POS[CR]

Receive: 98956[CR][LF]

Drive nodes at 500 rpm:

Transmit: V500[CR]

If ANSW2 is set, you will receive an "OK" for pure transmit commands if the command has been successfully executed, or one of the following character strings:

"Unknown command"

"Invalid parameter"

"Command not available"

"Overtemperature – drive disabled"

**Example:**

Transmit: V500[CR]

Receive: OK[CR][LF]

The SAVE/EEPSAV command always responds with the character string "EEPROM writing done" after successful saving of the current settings in the data Flash memory, or with "Flash defect", if the save has failed.

## 4 Parameter Description

### 4.1 Basic setting commands

The commands listed here are used for the configuration of basic setting parameters.

#### 4.1.1 Commands for special operating modes

Command	Argument	Function	Description
SOR	0-3	Source For Velocity	Source for velocity presetting 0: Serial interface (default) 1: Voltage at analog input 2: PWM signal at analog input 3: Current set-point via analog input
CONTMOD	–	Continuous Mode	Switch back from an extended mode to normal mode
STEPMOD	–	Stepper Motor Mode	Switch to stepper motor mode
APCMOD	–	Analog Position Control Mode	Switch to position control via analog voltage
ENCMOD	–	Encoder Mode	Switch to encoder mode (not for MCDC). An external encoder serves as position detector (the current position value is set to 0)
HALLSPEED	–	Hall sensor as Speed Sensor	Speed via Hall sensors in encoder mode (not for MCDC)
ENCSPEED	–	Encoder as Speed Sensor	Speed via encoder in encoder mode (not for MCDC)
GEARMOD	–	Gearing Mode	Switch to gearing mode
VOLTMOD	–	Set Voltage Mode	Activate voltage regulator mode
IXRMOD	–	Set IxR Mode	Activate IxR control (only MCDC)

#### 4.1.2 Parameters for basic settings

Command	Argument	Function	Description
ENCRES	Value	Load Encoder Resolution	Load resolution from external encoder. Value: 0 to 65535 (4 times pulse/rev)
MOTTYP	0-9	BL Motor Type	Setting for connected BL motor (only MCBL). 0: BL special motor according to KN and RM 1: 1628T012B K1155 2: 1628T024B K1155 3: 2036U012B K1155 4: 2036U024B K1155 5: 2444S024B K1155 6: 3056K012B K1155 7: 3056K024B K1155 8: 3564K024B K1155 9: 4490H024B K1155
KN	Value	Load Speed Constant	Load speed constant $K_n$ according to specifications in data sheet. Unit: rpm/V. (Only necessary for MOTTYP0 or DC motor)
RM	Value	Load Motor Resistance	Load motor resistance $R_M$ according to specification in data sheet. Unit: mOhm. (Only necessary for MOTTYP0 or DC motor)
STW	Value	Load Step Width	Load step width for step motor and gearing mode Value range: 0.....65535
STN	Value	Load Step Number	Load number of steps per revolution for step motor and gearing mode Value range: 0.....65535
MV	Value	Minimum Velocity	Presetting of minimum velocity in rpm for presetting via analog voltage (SOR1, SOR2) Value range: 0.....32767
MAV	Value	Minimum Analog Voltage	Presetting of minimum start voltage in mV for velocity presetting via analog voltage (SOR1, SOR2) Value range: 0.....10000
ADL	–	Analog Direction Left	Positive voltages at the analog input result in counter-clockwise rotation of the rotor (SOR1, SOR2)

## 4 Parameter Description

### 4.1 Basic setting commands

ADR	–	Analog Direction Right	Positive voltages at the analog input result in clockwise rotation of the rotor (SOR1, SOR2)
SIN	0-1	Sinus Commutation	1: No block commutation in the upper velocity range (default) 0: Block commutation in the upper velocity range (full modulation) (not with MCDC)
NET	0-1	Set Network Mode	Activate RS232 multiplex mode for network operation. 1: Network operation activated 0: No network operation, single drive on an RS232
BAUD	Value	Select Baud Rate	Preset transfer rate for RS232 interface
NODEADR	Value	Define Node Address	Set node number Value range: 0...255
COMPATIBLE	0-1	Set Compatible Mode	Set compatibility with predecessor models 1: Compatible mode activated 0: Compatible mode deactivated
ANSW	0-2	Answer Mode	0: No asynchronous responses 1: Permit asynchronous responses 2: All commands with confirmation and asynchronous responses

#### 4.1.3 General parameters

Command	Argument	Function	Description
LL	Value	Load Position Range Limits	Load limit positions (the drive cannot be moved out of these limits). Positive values specify the upper limit and negative values the lower. The range limits are only active if APL1 is. Value range: $-1.8 \cdot 10^9 \dots +1.8 \cdot 10^9$
APL	0-1	Activate / Deactivate Position Limits	Activate range limits (LL) (valid for all operating modes). 1: Position limits activated 0: Position limits deactivated
SP	Value	Load Maximum Speed	Load maximum speed. Value range: 0 to 32767 rpm. Setting applies for all modes.
AC	Value	Load Command Acceleration	Load acceleration value. Value range: 0...30000 $r/s^2$
DEC	Value	Load Command Deceleration	Load deceleration value Value range: 0...30000 $r/s^2$
SR	Value	Load Sampling Rate	Load sampling rate of the velocity controller as a multiplier of 100 $\mu s$ . Value Range: 1...20 ms/10
POR	Value	Load Velocity Proportional Term	Load velocity controller amplification. Value range: 1...255
I	Value	Load Velocity Integral Term	Load velocity controller integral term. Value range: 1...255
PP	Value	Load Position Proportional Term	Load position controller amplification. Value range: 1...255
PD	Value	Load Position Differential Term	Load position controller D-term. Value range: 1...255
CI	Value	Load Current Integral Term	Load integral term for current controller. Value range: 1...255
LPC	Value	Load Peak Current Limit	Load peak current. Value range: 0...12000 mA
LCC	Value	Load Continuous Current Limit	Load continuous current. Value range: 0...12000 mA
DEV	Value	Load Deviation	Load maximum permissible deviation of actual velocity from target velocity (deviation) Value range: 0...32767
CORRIDOR	Value	Load Corridor	Window around the target position. Value range: 0...65535

## 4 Parameter Description

### 4.1 Basic setting commands

#### 4.1.4 Configuration of fault pin and digital inputs

Command	Argument	Function	Description
ERROUT	–	Error Output	Fault pin as error output
ENCOUT	–	Encoder Output	Fault pin as pulse output (not with MCDC)
DIGOUT	–	Digital Output	Fault pin as digital output. The output is set to low level.
DIRIN	–	Direction Input	Fault pin as rotational direction input
REFIN	–	Reference Input	Fault pin as reference or limit switch input
DCE	Value	Delayed Current Error	Delayed error output for ERROUT in 1/100 sec. Value range: 0...65535
LPN	Value	Load Pulse Number	Preset pulse number for ENCOUT. Value range: 1...255
CO	–	Clear Output	Set digital output DIGOUT to low level
SO	–	Set Output	Set digital output DIGOUT to high level
TO	–	Toggle Output	Switch digital output DIGOUT
SETPLC	–	Set PLC inputs	Digital inputs PLC-compatible (24 V level)
SETTTL	–	Set TTL inputs	Digital inputs TTL-compatible (5 V level)

#### 4.1.5 Configuration of homing and limit switches in FAULHABER mode

Command	Argument	Function	Description
HP	Value	Hard Polarity	Define valid edge and polarity of respective limit switches: 1: Rising edge or high level valid. 0: Falling edge or low level valid.
HB	Value	Hard Blocking	Activate Hard Blocking function for relevant limit switch.
HD	Value	Hard Direction	Presetting of direction of rotation that is blocked with HB of respective limit switch. 1: Clockwise rotation blocked 0: Counterclockwise rotation blocked
SHA	Value	Set Home Arming for Homing Sequence	Homing behaviour (GOHOSEQ): Set position value to 0 at edge of respective limit switch.
SHL	Value	Set Hard Limit for Homing Sequence	Homing behaviour (GOHOSEQ): Stop motor at edge of respective limit switch.
SHN	Value	Set Hard Notify for Homing Sequence	Homing behaviour (GOHOSEQ): Send character to RS232 at edge of respective limit switch.
HOSP	Value	Load Homing Speed	Load speed and direction of rotation for homing (GOHOSEQ, GOHIX, GOIX). Value range: –32767...32767 rpm
POHOSEQ	0-1	Power-On Homing Sequence	Start homing automatically after power-on. 1: Power-On Homing Sequence activated. 0: No homing after power-on.
HA	Value	Home Arming	Set position value to 0 and delete relevant HA bit at edge of respective limit switch. Setting is not stored.
HL	Value	Hard Limit	Stop motor and delete relevant HL bit at edge of respective limit switch. Setting is not stored.
HN	Value	Hard Notify	Send character to RS232 and delete relevant HN bit at edge of respective limit switch. Setting is not stored.

Limit switch bit mask:

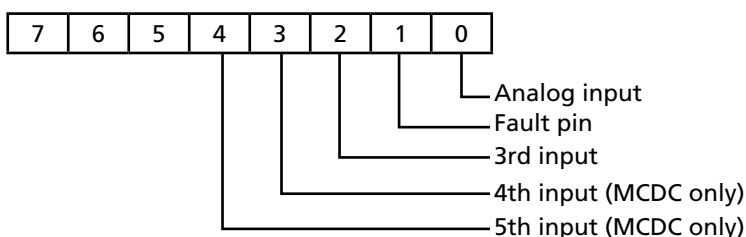

## 4 Parameter Description

### 4.2 Query commands for basic settings

#### 4.2.1 Operating modes and general parameters

Command	Argument	Function	Description		
CST	-	Configuration Status	Set operating mode. Return value binary coded (LSB=Bit 0): Bit 0, Compatible mode 0: COMPATIBLE0 1: COMPATIBLE1 Bit 1-2: Automatic responses 0: ANSW0 (no automatic responses) 1: ANSW1 (asynchronous responses) 2: ANSW2 (additional command acknowledgements) Bit 3-4, Velocity presetting: 0:SOR0 (RS232 interface) 1:SOR1 (Analog voltage) 2:SOR2 (PWM signal) 3:SOR3 (current limitation value) Bit 5-6, reserved Bit 7-9, FAULHABER mode: 0:CONTMOD 1:STEPMOD 2:APCMOD 3:ENCMOD / HALLSPEED 4:ENCMOD / ENCSPEED 5:GEARMOD 6:VOLTMOD 7:IXRMOD Bit 10, Power amplifier: 0:Disabled (DI) 1:Enabled (EN) Bit 11, Position controller: 0: Switched off 1: Switched on Bit 12, Analog direction of rotation: 0:ADL 1:ADR Bit 13, Position Limits APL: 0:Deactivated 1:Activated Bit 14, Sinus commutation SIN: 0:Permit block commutation 1:Do not permit block commutation Bit 15, Network operation 0: NET0 (Single device on an RS232) 1: NET1 (Multiplex mode activated)		
GMOD	-	Get Mode	MCDC D S A - - G V I	MCBL/ 3564K024B CS c s a h e g v -	Set FAULHABER mode CONTIMOD STEPMOD APCMOD ENCMOD ENCSPEED GEARMOD VOLTMOD IxRMOD

## 4 Parameter Description

### 4.2 Query commands for basic settings

Command	Argument	Function	Description
GENCRES	–	Get Encoder Resolution	Set encoder resolution ENCRES
GMOTTYP	–	Get Motor Type	Set motor type 0-9 (MOTTYP) –1: DC motor
GKN	–	Get Speed Constant	Speed constant for MOTTYP0 or DC motor in rpm/V
GRM	–	Get Motor Resistance	Motor resistance for MOTTYP0 or DC motor in mOhm
GTYP	–	Get Controller Type	Query controller designation
GSER	–	Get Serial Number	Query serial number
GSTW	–	Get Step Width	Set step width STW
GSTN	–	Get Step Number	Set step number per revolution STN
GMV	–	Get Minimum Velocity	Set minimum speed MV in rpm
GMAV	–	Get Minimum Analog Voltage	Set minimum start voltage value MAV in mV
GPL	–	Get Positive Limit	Set positive limit position LL
GNL	–	Get Negative Limit	Set negative limit position LL
GSP	–	Get Maximum Speed	Set maximum speed SP in rpm
GAC	–	Get Acceleration	Set acceleration value AC in $r/s^2$
GDEC	–	Get Deceleration	Set deceleration value DEC in $r/s^2$
GSR	–	Get Sampling Rate	Set sampling rate of velocity controller in ms/10
GPOR	–	Get Velocity Prop. Term	Set amplification value of velocity controller POR
GI	–	Get Velocity Integral Term	Set integral term of velocity controller I
GPP	–	Get Position Prop. Term	Set amplification value of position controller PP
GPD	–	Get Position D-Term	Set D-term of position controller PD
GCI	–	Get Current Integral Term	Set integral term of current controller CI
GPC	–	Get Peak Current	Set peak current PC in mA
GCC	–	Get Continuous Current	Set continuous current CC in mA
GDEV	–	Get Deviation	Set deviation value DEV
GCORRIDOR	–	Get Corridor	Set window around target position
GNODEADR	–	Get Node Address	Set node number



## 4 Parameter Description

### 4.2 Query commands for basic settings

Query commands of predecessor models that are no longer supported for reasons of compatibility:

Command	Argument	Function	Description
GST	-	Get Status	<p>Report current status. 7 ASCII characters "0" and "1" from left to right:</p> <p>Pos. 0: 1: Position controller active 0: Velocity controller active</p> <p>Pos. 1: 1: Velocity presetting analog or PWM 0: Velocity presetting via RS232</p> <p>Pos. 2: 1: Velocity presetting via PWM (Pos. 1 = 1) 0: Velocity presetting analog (Pos. 1 = 1)</p> <p>Pos. 3: 1: Drive is active (enabled) 0: Drive is inactive (disabled)</p> <p>Pos. 4: 1: Target position attained 0: Target position not attained</p> <p>Pos. 5: 1: Positive limit switch edge effective 0: Negative limit switch edge effective</p> <p>Pos. 6: 1: Limit switch at high level 0: Limit switch at low level</p>
GFS	-	Get Fault Status	<p>Report status of error output. 4 ASCII characters "0" and "1" from left to right (0=no error, 1=error):</p> <p>Pos. 0: Overtemperature protection Pos. 1: Current limitation controller Pos. 2: Reserved (always 0) Pos. 3: Overvoltage regulator</p>
GAST	-	Get Actual Status	<p>Report current status. 4 ASCII characters "0" and "1" from left to right:</p> <p>Pos. 0: 1: Limit switch 2 at high level 0: Limit switch 2 at low level</p> <p>Pos. 1: 1: Limit switch 3 at high level 0: Limit switch 3 at low level</p> <p>Pos. 2: 1: Clockwise rotation with positive values 0: Counter-clockwise rotation with positive values</p> <p>Pos. 3: 1: Homing still active 0: Homing ended</p>

## 4 Parameter Description

### 4.2 Query commands for basic settings

Command	Argument	Function	Description
GSCS	–	Get Special Configuration Set	<p>Report special settings.</p> <p>8 ASCII characters "0" and "1" from left to right:</p> <p>Pos. 0: 1: Release homing after power-on 0: Homing blocked after power-on</p> <p>Pos. 1: 1: Fault pin is input 0: Fault pin is output</p> <p>Pos. 2: 1: Pulse output at fault pin (Pos. 1=0) 0: Error signal at fault pin (Pos. 1=0)</p> <p>Pos. 3: 1: Pos. 1=1: Fault pin is rotational direction input Pos. 1=0: Fault pin is digital output 0: Pos. 1=1: Fault pin is limit switch input 2 Pos. 1=0: Fault pin is not digital output</p> <p>Pos. 4: 1: Positive edge at limit switch 2 effective 0: Negative edge at limit switch 2 effective</p> <p>Pos. 5: 1: Positive edge at limit switch 3 effective 0: Negative edge at limit switch 3 effective</p> <p>Pos. 6: 1: Release motion program 0: Motion program blocked</p> <p>Pos. 7: 1: Release automatic responses 0: No automatic responses</p>
GES	–	Get Enhanced Status	<p>Report enhanced status.</p> <p>5 ASCII characters "0" and "1" from left to right:</p> <p>Pos. 0: 1: Input no.4 at high level (MCDC) 0: Input no.4 at low level (MCDC)</p> <p>Pos. 1: 1: Input no. 5 at high level (MCDC) 0: Input no. 5 at low level (MCDC)</p> <p>Pos. 2: 1: Analog target current presetting active 0: No analog target current presetting</p> <p>Pos. 3: 1: Position limits active in all modes 0: Position limits inactive</p> <p>Pos. 4: 1: Deviation error is present 0: No deviation error present</p>
GAHS	–	Get Actual Homing Status	<p>Current reference switch settings.</p> <p>5 ASCII characters "0" to "7" from left to right:</p> <p>Pos. 0: HA value Pos. 1: HL value Pos. 2: HN value Pos. 3: HB value Pos. 4: HD value</p>
GHSC	–	Get Homing Sequence Configuration	<p>Setting of homing sequence.</p> <p>3 ASCII characters "0" to "7" from left to right:</p> <p>Pos. 0: SHA value Pos. 1: SHL value Pos. 2: SHN value</p>

## 4 Parameter Description

### 4.2 Query commands for basic settings

#### 4.2.2 Configuration of fault pin and digital inputs

Command	Argument	Function	Description
IOC	–	I/O Configuration	Set input/output configuration. Return value binary coded (LSB=Bit 0): Bit 0-7, Hard Blocking: 0-7: Function active for input 1-3 Bit 8-15, Hard Polarity: 0-7: Rising edge at input 1-3 Bit 16-23, Hard Direction: 0-7: Clockwise rotation stored at input 1-3 Bit 24, State of digital output: 0: Low 1: High Bit 25, Level of digital inputs: 0: TTL level (5V) 1: PLC level (24 V) Bit 26-28, Function of fault pin: 0: ERROUT 1: ENCOUT 2: DIGOUT 3: DIRIN 4: REFIN
GDCE	–	Get Delayed Current Error	Set value of error output delay DCE
GPN	–	Get Pulse Number	Set pulse number LPN

#### 4.2.3 Configuration of homing

Command	Argument	Function	Description
HOC	–	Homing Configuration	Set homing configuration. Return values binary coded (LSB=Bit 0): Bit 0-7, SHA setting for input 1-8 Bit 8-15, SHN setting for input 1-8 Bit 16-23, SHL setting for input 1-8 (input 6-8: Reserved) Bit 24, Power-On Homing Sequence 0: deactivated 1: activated (homing after power-on)
GHOSP	–	Get Homing Speed	Set homing speed in rpm

## 4 Parameter Description

### 4.3 Miscellaneous commands

Command	Argument	Function	Description
NE	0-1	Notify Error	Notification in the event of error 1: An "r" is returned if an error occurs 0: No notification in the event of error
SAVE EEPSAV	–	Save Parameters	Save current parameters and configuration setting to Flash memory. The drive will also start with these settings when next switched on. Attention: Command must not be executed more than 10,000 times, as otherwise the function of the Flash memory can no longer be guaranteed.
RESET	–	Reset	Restart drive node.
RN	–	Reset Node	Set parameters to original values (ROM values) (current, acceleration, controller parameters, maximum speed, limit positions...)
FCONFIG	–	Factory Configuration	All configurations and values are reset to the delivery status. The drive is deactivated after this command.

## 4 Parameter Description

### 4.4 Motion control commands

Command	Argument	Function	Description
DI	–	Disable Drive	Deactivate drive.
EN	–	Enable Drive	Activate drive.
M	–	Initiate Motion	Activate position control and start positioning.
LA	Value	Load Absolute Position	Load new absolute target position. Value range: $-1.8 \cdot 10^9 \dots 1.8 \cdot 10^9$
LR	Value	Load Relative Position	Load new relative target position, in relation to last started target position. Resulting absolute target position must be between $-2.14 \cdot 10^9$ and $2.14 \cdot 10^9$ .
NP	–/Value	Notify Position	Without argument: A “p” is returned when the target position is attained. With argument: When the specified position is over-travelled, a “p” is returned Value range: $-1.8 \cdot 10^9 \dots 1.8 \cdot 10^9$
NPOFF	–	Notify Position Off	A Notify Position command that has not yet been triggered is deactivated again.
V	Value	Select Velocity Mode	Activate velocity mode and set specified value as target velocity. (Velocity control) Value range: $-32767 \dots 32767$ rpm
NV	Value	Notify Velocity	When the specified speed is reached or passed, a “v” is returned. Value range: $-32767 \dots 32767$ rpm
NVOFF	–	Notify Velocity Off	A Notify Velocity command that has not yet been triggered is deactivated again. Uv instead of Ur
U	Value	Set Output Voltage	Output PWM value in VOLTMOD. Value range: $-32767 \dots 32767$ rpm (corresponds to $-Uv \dots +Uv$ )
GOHOSEQ	–	Go Homing Sequence	Execute FAULHABER homing sequence. A homing sequence is executed (if programmed) independently of the current mode.
GOHIX	–	Go Hall Index	Move BL motor to Hall zero point (Hall index) and set actual position value to 0 (not for MCDC)
GOIX	–	Go Encoder Index	Move to the Encoder Index at the fault pin and set actual position value to 0 (DC motor or ext. encoder)
HO	–/Value	Define Home-Position	Without argument: Set actual position to 0. With argument: Set actual position to specified value. Value range: $-1.8 \cdot 10^9 \dots +1.8 \cdot 10^9$

## 4 Parameter Description

### 4.5 General query commands

Command	Argument	Function	Description
POS	–	Get Actual Position	Current actual position
TPOS	–	Get Target Position	Target position of last M command
GV	–	Get Velocity	Current target velocity in rpm
GN	–	Get N	Current actual velocity in rpm
GU	–	Get PWM Voltage	Set PWM value in VOLTMOD
GRU	–	Get Real PWM Voltage	Current controller output value
GCL	–	Get Current Limit	Current limitation current in mA
GRC	–	Get Real Current	Current actual current in mA
TEM	–	Get Temperature	Current housing temperature in °C
VER	–	Get Version	Current software version
OST	–	Operation Status	Display current operating status. Return value binary coded (LSB=Bit 0): Bit 0: Homing running Bit 1: Program sequence running Bit 2: Program sequence stopped because of DELAY command Bit 3: Program sequence stopped because of NOTIFY command Bit 4: Current limitation active Bit 5: Deviation error Bit 6: Overvoltage Bit 7: Overtemperature Bit 8: Status input 1 Bit 9: Status input 2 Bit 10: Status input 3 Bit 11: Status input 4 Bit 12: Status input 5 Bit 13-15: Reserved for further inputs Bit 16: Position attained
SWS	–	Switch Status	Temporary limit switch settings. Return value binary coded (LSB = Bit 0): Bit 0-7: HA setting for input 1-8 Bit 8-15: HN setting for input 1-8 Bit 16-23: HL setting for input 1-8 Bit 24-31: Specifies which limit switch 1-8 has already switched (is reset again when the respective input is reset)

## 4 Parameter Description

### 4.6 Commands for sequence programs

Commands for generating and executing sequence programs:

Command	Argument	Function	Description
PROGSEQ [...] END	–	Program Sequence	<p>Defines the start and end of a sequence program.</p> <p>All commands sent to PROGSEQ are not executed, but transferred to the sequence program memory. An END marks the end of the sequence program.</p> <p>There is no SAVE command necessary for saving the programm sequence.</p> <p>Attention: Command must not be executed more than 10,000 times, as otherwise the function of the Flash memory can no longer be guaranteed.</p> <p>All commands after END are directly executed again.</p> <p>These commands do not have to be entered in the FAULHABER Motion Manager, as they are automatically attached by the "Transfer program file..." function.</p>
GPROGSEQ	–	Get Program Sequence	<p>Reads out and sends back the stored program sequence. Each program line is output in lower case letters, ending with a CR character. At the end of the program the line "end:" is sent, with specification of the program length in bytes followed by a CR and LF character.</p>
ENPROG	–	Enable Program	<p>Execution of the program is released, i.e. the sequence is started.</p> <p>This status can be permanently stored with SAVE/EEPSAV, so that the drive starts up with the stored program sequence immediately after switch-on.</p>
DIPROG	–	Disable Program	<p>Deactivate program execution.</p>
RESUME	–	Resume	<p>Continue program sequence after DIPROG at the point where it was interrupted.</p>
MEM	–	Memory	<p>Send back available program memory in words.</p>

## 4 Parameter Description

### 4.6 Commands for sequence programs

Additional commands for use within sequence programs:

Command	Argument	Function	Description
DELAY	Value	Delay	Stop sequence for a defined period Argument: in 1/100 seconds Value: 0...65535
TIMEOUT	Value	Timeout	With Notify commands, only wait for the specified time and then continue the sequence again. A "o" on RS232 if Notify condition has not been fulfilled. Argument: in 1/100 seconds Value: 0...65535 (Can also be used via RS232).
JMP	Adr	Jump	Jump to specified address. (Can also be used via RS232). Address: 0...255
JMPGx	Adr	Jump if greater than x	Jump to specified address if result of last query command is greater than the variable x (A, B, C).
JMPLx	Adr	Jump if less than x	Jump to specified address if result of last query command is less than the variable x (A, B, C).
JMPEx	Adr	Jump if equal x	Jump to specified address if result of last query command is equal to the variable x (A, B, C).
JPH	Adr	Jump if Hard-Input activated	Jump to specified address if Analog Input is active (HP defines the polarity). Address: 0...255
JPF	Adr	Jump if Fault-Input activated	Jump to specified address if Fault Pin Input is active (HP defines the polarity). Address: 0...255
JPT	Adr	Jump if 3. Input activated	Jump to specified address if the 3rd Input is active (HP defines the polarity). Address: 0...255
JPD (only MCDC)	Adr	Jump if 4. Input activated	Jump to specified address if 4th Input is active (HP defines the polarity).
JPE (only MCDC)	Adr	Jump if 5. Input activated	Jump to specified address if 5th Input is active (HP defines the polarity).
SETx	Value	Set Variable x	Set Variable x (A, B, C) to specified value. Value: 0...65535
GETx	–	Get Variable x	Query content of Variable x (A, B, C).
DxJNZ	Adr	Decrement x, Jump if not Zero	Decrease the value of Variable x (A, B, C) by one and jump to specified address if the value is not 0. Address: 0...255
ERI	Adr	Error Interrupt	An Error Interrupt is activated from execution of this command. This means that whenever an error occurs after this (overvoltage, current limitation...), the sequence branches to the specified address. Error handling mode is ended when a JMP or RETI command is executed. Address: 0...255
RETI	–	Return Error Interrupt	Return from an error handling routine. Important: The interrupted command will no longer be executed, even if it had not been completed at the time of the interruption!
DIERI	–	Disable Error Interrupt	The ERI command is deactivated, i.e. in the event of an error the sequence no longer jumps to the error handling routine.
CALL	Adr	Call Subroutine	Call a subroutine at specified address. Address: 0...255
RET	–	Return from Subroutine	Return from a subroutine. Please note that only one subroutine level is possible, i.e. no subroutines may be called within subroutines!
A	Adr	Define Address	Definition of the current position as entry address for jump commands Address: 0...255



## 5 Appendix

### 5.1 Electromagnetic compatibility (EMC)

The FAULHABER Motion Controllers MCBL 3003/06 S, MCDC 3003/06 S and 3564K024B CS have been checked and tested in accordance with EMC directive 89/336/EEC for compliance with EMC protective requirements.

In nominal operation the system fulfils the requirements of the following standards:

EMC emissions within the limits of the basic technical standards for emitted interference in the industrial sector EN 61000-6-4 (August 2002)

EMC immunity in accordance with the basic technical standards for interference resistance in the industrial sector EN 61000-6-2 (August 2002)

- Electrostatic discharges ESD with 4 kV (contact discharge) and 8 kV (atmospheric discharge) in accordance with EN 61000-4-2 (December 2001)
- HF fields in accordance with EN 61000-4-3 (November 2003)
- Rapid transients in accordance with EN 61000-4-4 (July 2002)
- Transient voltages in accordance with EN 61000-4-5 (December 2001)
- Conducted disturbance variables, induced by high-frequency fields in accordance with EN 61000-4-6 (December 2001)
- Magnetic field with power engineering frequencies in accordance with EN 61000-4-8 (December 2001)

The following conditions must be fulfilled for compliance with the requirements:

- Operation in accordance with the technical data and the operating instructions
- The supply line must be led through a suitable ferrite tube with two windings (e.g. Würth Elektronik no.: 742 700 90), as close as possible to the control.

#### **Supporting measures for conducted interferences:**

Further suppression measures are required, in order to comply with the limit values on the DC connecting line that are prescribed for AC supply points in accordance with the above-specified standard (EN 61000-6-4).

In addition to the ferrite tube, a current-compensated choke (e.g. Würth Elektronik no.: 744 825 605) with electrolytic capacitor 470 µF must be installed in the supply line, as close as possible to the control.

#### **5.1.1 Intended use**

The units are developed, manufactured, tested and documented in compliance with the pertinent standards.

If used as intended, the units do not give rise to any risks for people or property. Intended use assumes that the units are used exclusively as described here and that all safety instructions and regulations are complied with.

Intended use also includes observance of the pertinent regulations in respect of safety (Machinery Directive) and radio shielding (EMC Directive) when using the units.

Electronic devices are not fail-safe in principle. The user must ensure that, in the event of failure of the device, the drive is put into a safe condition.

Dr. Fritz Faulhaber GmbH & Co. KG cannot accept any liability for direct or consequential damages resulted from misuse of the units.

#### **5.1.2 CE marking**

The devices fulfil the requirements of DIN EN 61000-6-2 regarding immunity to interference in the industrial sector and of DIN EN 61000-6-4 in relation to emitted interference in the industrial sector.

Protection against contact may need to be provided around the units in order to comply with the Machinery Directive. Depending on loading, temperatures above 85 °C can occur on the device surface.

There are no requirements from the Low Voltage Directive, as the operating voltage may not reach 50 V or over at any point in time.

In order to fulfil the necessary standards for CE marking, the line lengths from and to the Motion Controller must not exceed 3 meters. All connecting lines must comply with the state-of-the-art and all additional connection and installation regulations in this description.

Additional circuits and measures such as e.g. ferrite tube, suppressor diodes and shield connection may be required to comply with special requirements.

## 5 Appendix

### 5.2 Configuration at delivery

The standard configuration parameters with which the units are delivered are listed below. These settings can also be reloaded at any time with the command FCONFIG, followed by a hardware reset.

#### 3564K024B CS:

FAULHABER Command	Description
CONTMOD	Normal operation
APL0	Position limits deactivated
SOR0	Velocity presetting via RS232
MOTYP8	Motor type 3564K024B K1155
ERROUT	Fault pin = Error output
HP7	All inputs react to rising edge
HB0, HD0	No Hard Blocking limit switch defined
HOSP100	Homing Speed = 100 rpm
SHA0, SHL0, SHN0	No FAULHABER homing sequence defined
ADR	Analog direction of rotation right
LPC8000	Peak current limitation = 8 A
LCC2800	Continuous current limitation = 2.8 A
AC30000	Acceleration = 30000 r/s <sup>2</sup>
DEC30000	Deceleration ramp = 30000 r/s <sup>2</sup>
SR1	Sampling rate = 100 $\mu$ s
I40	I-term of velocity controller
POR8	P-term of velocity controller
PP12	P-term of position controller
PD6	D-term of position controller
CI50	I-term of current controller
SP12000	Limitation of maximum velocity to 12000 rpm
MV0	Minimum analog velocity
MAV25	Minimum analog voltage
LL1800000000	Upper positioning range limit
LL-1800000000	Lower positioning range limit
LPN16	Numeric value for pulse output
STW1	Step width for special operation
STN1000	Step number for special operation
ENCRES2048	Resolution of external encoder
DEV30000	Do not monitor deviation error
DCE200	Error delay 2 sec.
CORRIDOR20	Target corridor for positionings
SIN1	Do not permit block commutation
SETPLC	Digital inputs PLC-compatible
NET0	Multiplex mode deactivated
BAUD9600	Transfer rate 9600 baud
NODEADR0	Node number = 0
COMPATIBLE0	Not in compatibility mode
ANSW2	Asynchronous response activated
POHOSEQ0	No homing sequence after power-on
DIPROG	Sequence programs deactivated
DI	Power stage deactivated
V0	Nominal speed value = 0 rpm

#### MCBL 3003/06 S:

FAULHABER Command	Description
CONTMOD	Normal operation
APL0	Position limits deactivated
SOR0	Velocity presetting via RS232
MOTYP5	Motor type 2444S024B K1155
ERROUT	Fault pin = Error output
HP7	All inputs react to rising edge
HB0, HD0	No Hard Blocking limit switch defined
HOSP100	Homing Speed = 100 rpm
SHA0, SHL0, SHN0	No FAULHABER homing sequence defined
ADR	Analog direction of rotation right
LPC5000	Peak current limitation = 5 A
LCC1370	Continuous current limitation = 1.37 A
AC30000	Acceleration = 30000 r/s <sup>2</sup>
DEC30000	Deceleration ramp = 30000 r/s <sup>2</sup>
SR1	Sampling rate = 100 $\mu$ s
I40	I-term of velocity controller
POR7	P-term of velocity controller
PP16	P-term of position controller
PD9	D-term of position controller
CI50	I-term of current controller
SP30000	Limitation of maximum velocity to 30000 rpm
MV0	Minimum analog velocity
MAV25	Minimum analog voltage
LL1800000000	Upper positioning range limit
LL-1800000000	Lower positioning range limit
LPN16	Numeric value for pulse output
STW1	Step width for special operation
STN1000	Step number for special operation
ENCRES2048	Resolution of external encoder
DEV30000	Do not monitor deviation error
DCE200	Error delay 2 sec.
CORRIDOR20	Target corridor for positionings
SIN1	Do not permit block commutation
SETPLC	Digital inputs PLC-compatible
NET0	Multiplex mode deactivated
BAUD9600	Transfer rate 9600 baud
NODEADR0	Node number = 0
COMPATIBLE0	Not in compatibility mode
ANSW2	Asynchronous response activated
POHOSEQ0	No homing sequence after power-on
DIPROG	Sequence programs deactivated
DI	Power stage deactivated
V0	Nominal speed value = 0 rpm

## 5 Appendix

### 5.2 Configuration at delivery

#### MCDC 3003/06 S:

FAULHABER Command	Description
CONTMOD	Normal operation
APL0	Position limits deactivated
SOR0	Velocity presetting via RS232
ERROUT	Fault pin = Error output
HP31	All inputs react to rising edge
HB0, HD0	No Hard Blocking limit switch defined
HOSP100	Homing Speed = 100 rpm
SHA0, SHL0, SHN0	No FAULHABER homing sequence defined
ADR	Analog direction of rotation right
LPC10000	Peak current limitation = 10 A
LCC5000	Continuous current limitation = 5 A
AC30000	Acceleration = 30000 r/s <sup>2</sup>
DEC30000	Deceleration ramp = 30000 r/s <sup>2</sup>
SR1	Sampling rate = 100 µs
I50	I-term of velocity controller
POR10	P-term of velocity controller
PP10	P-term of position controller
PD5	D-term of position controller
CI40	I-term of current controller
SP30000	Limitation of maximum velocity to 30000 rpm
MV0	Minimum analog velocity
MAV25	Minimum analog voltage
LL1800000000	Upper positioning range limit
LL-1800000000	Lower positioning range limit
LPN16	Numeric value for pulse output
STW1	Step width for special operation
STN1000	Step number for special operation
ENCRE2048	Resolution of external encoder
DEV30000	Do not monitor deviation error
DCE200	Error delay 2 sec.
CORRIDOR20	Target corridor for positionings
SETPLC	Digital inputs PLC-compatible
NET0	Multiplex mode deactivated
BAUD9600	Transfer rate 9600 baud
NODEADR0	Node number = 0
COMPATIBLE0	Not in compatibility mode
ANSW2	Asynchronous response activated
POHOSEQ0	No homing sequence after power-on
DIPROG	Sequence programs deactivated
RM3300	Motor resistance = 3.3 Ω
KN398	Velocity constant = 398 rpm/V
DI	Power stage deactivated
V0	Nominal speed value = 0 rpm

## Notes

---

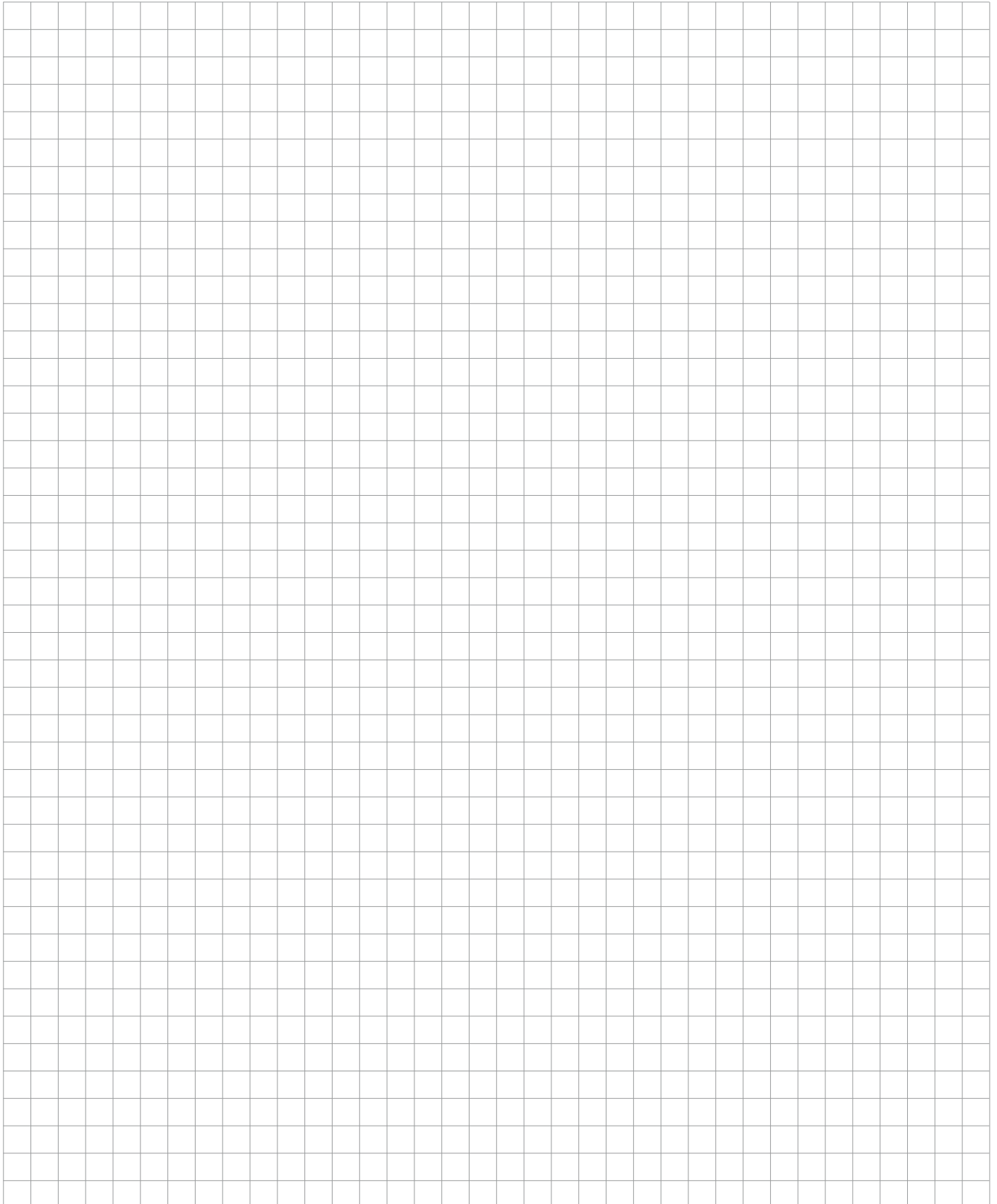

**NEW**

# Brushless DC-Servomotor

## 50 mNm

with integrated Motion Controller  
and RS232 interface

For combination with  
Gearheads:  
30/1, 32/3, 38/1, 38/2

### Series 3564K024B CS

	3564 K	024 B CS	
Nominal voltage	$U_N$	24	Volt
Output power	$P_{2\text{ max.}}$	90	W
Efficiency	$\eta_{\text{ max.}}$	80	%
No-load speed	$n_o$	10 500	rpm
No-load current	$I_o$	0,28	A
Peak torque for 8 A	$M_P$	160	mNm
Friction torque:			
– static	$C_o$	1,10	mNm
– dynamic	$C_v$	$2,4 \cdot 10^{-4}$	mNm/rpm
Torque constant	$k_M$	20,2	mNm/A
Current constant	$k_I$	0,05	A/mNm
Slope of n/M curve	$\Delta n/\Delta M$	31	rpm/mNm
Mechanical time constant	$\tau_m$	11	ms
Rotor inertia	$J$	34	gcm <sup>2</sup>
Angular acceleration	$\alpha_{\text{ max.}}$	109	10 <sup>3</sup> rad/s <sup>2</sup>
Thermal resistance	$R_{th 1} / R_{th 2}$	2,5 / 6,3	K/W
Thermal time constant	$\tau_{w1} / \tau_{w2}$	23 / 1 175	s
Operating temperature range		- 5 ... + 85	°C
Shaft bearings		ball bearings, preloaded	
Shaft load max.:			
– radial at 3000 rpm (7,4 mm from mounting flange)		108	N
– axial at 3000 rpm (push-on only)		50	N
– axial at standstill (push-on only)		131	N
Shaft play:			
– radial	$\mu$	0,015	mm
– axial	$\parallel$	0	mm
Housing material		aluminium, black anodized	
Weight with electronics		440	g
Direction of rotation		electronically reversible	
<b>Recommended values</b>			
Speed range <sup>1)</sup>	$n_e$	5 - 12 000	rpm
Torque up to <sup>2)</sup>	$M_e \text{ max.}$	50	mNm
Current up to <sup>2)</sup>	$I_e \text{ max.}$	2,80 <sup>3)</sup>	A

<sup>1)</sup> Power rating of 44 Watt at 8 400 rpm and 50 mNm

<sup>3)</sup> This is a preset value and can be changed

<sup>2)</sup> thermal resistance  $R_{th 2}$  by 55% reduced

over the RS232 interface

scale reduced

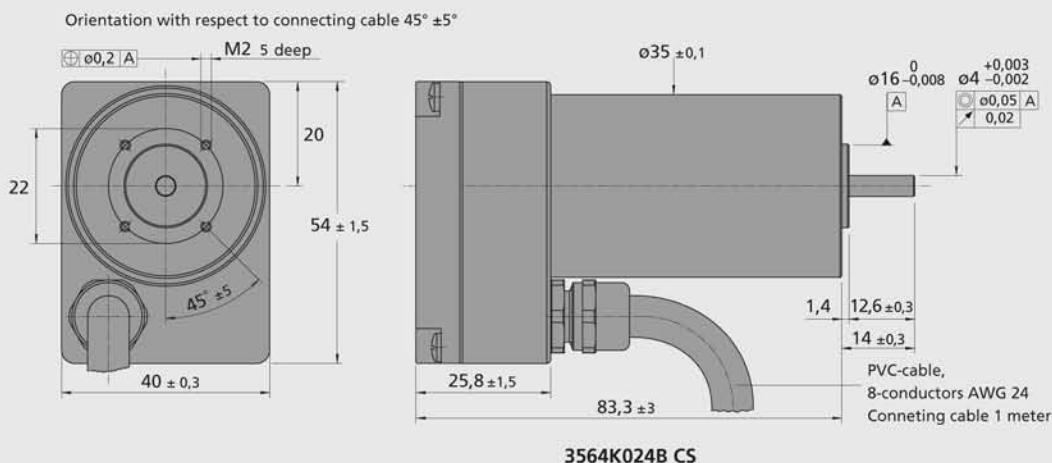

#### Connection

Wires	Function
blue	GND
pink	+ 24 V
brown	Analog input
white	Fault output
grey	Analog GND
yellow	RS232 RXD
green	RS232 TXD
red	Connection No. 3

#### Caution:

be sure to connect motor supply terminals to the correct polarity. Motor electronics are protected against polarity reversal by an internal fuse. In case of damage due to polarity reversal, this internal fuse can only be replaced at the factory.

Motion Controller				
Supply voltage <sup>1)</sup>	$U_B$		12 ... 30	V DC
Peak current <sup>2)</sup>	$I_{max}$		8	A
Input/output (see connection No. 1, 2 and 3)			3	
Connection No. 1 (brown)				
- Speed command analog input		voltage range	$\pm 10$	V
- Speed command PWM input		frequency range	100 ... 2 000	Hz
		pulse duty factor 50%	0	rpm
- Digital input		input resistance	5	k $\Omega$
- External encoder	$f_{max}$		400	kHz
- Step frequency input	$f_{max}$		400	kHz
Connection No. 2 (white)				
- Fault output		no error	switched to GND	
- Digital output		open collector	max. $U_B / 30$ mA	
- Digital input		input resistance	100	k $\Omega$
Connection No. 3 (red)				
- Digital input		input resistance	22	k $\Omega$
- Electronic supply voltage <sup>1)</sup>	$U_B$		12 ... 30	V DC
Encoder:				
- Scanning rate			100	$\mu$ s
- Resolution internal encoder			3 000	per turn

The signal level of the digital inputs can be set using the above commands:  
Standard (SPS): Low 0...7V / High 12,5V... $U_B$ , TTL: Low 0...0,5V / High 3,5V... $U_B$

<sup>1)</sup> A separate supply for motor and drive electronic is optional available (important for safety-relevant applications), here escapes the digital input, connection 3 (red).

<sup>2)</sup> Preset value. Can be changed over the interface.

### Position control

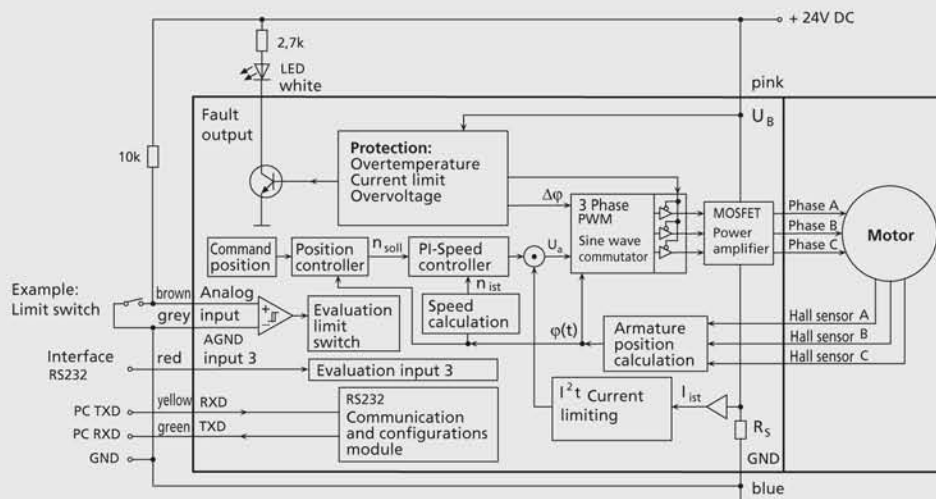

## Brushless DC-Servomotor with integrated Motion Controller

### General description

The 3564K024B CS combines an electronically commutated DC-Servomotor, a high-resolution absolute encoder and a programmable position and speed controller, based on a high-capacity digital signal processor (DSP), within a complete drive unit.

This intelligent EC servomotor performs the following drive functions:

- **Speed control** from 5 to 12 000 rpm with superior performance specifications in respect of synchronous operation and minimal torque fluctuations. A PI controller ensures observance of set-point speeds.
- **Speed profiles** such as ramp, triangular or trapezoidal movements are possible. Gentle acceleration or deceleration can be implemented without problem.
- **Positioning mode:** Positioning with a resolution of 1/3 000 revolutions. Acquisition of **reference marks and end position switches**.
- **Stepper motor mode, electronic gear** or operation with external **incremental encoder** for high-precision applications.
- **Torque control** through current regulation.
- **Self-protection** against excess temperature in the case of high loading, against over-voltage during generator operation and against under-voltage.
- **Storage** of the desired functions.
- **Storage** and execution of motion programs.

Various inputs and outputs are available for implementation of these functions:

- **Set-point input** for speed presetting. Analogue or PWM signal can be used. The input can also read in a reference mark signal. Depending on mode, a frequency signal or external incremental encoder can also be connected.
- **Error output** (Open Collector). Can also be reprogrammed as a rotational direction or reference mark input.
- **RS232 interface** for connection to a PC with a transfer rate of up to 115k baud. The information can be stored in the integrated memory (FLASH). The interface also offers the facility to retrieve online operating data and values.
- **Additional digital input.**

An extensive ASCII command set is available for **programming** and operation. This can be preset from the PC, e.g. via any terminal program, as contained in Windows, or via any other control computer.

For Windows 95/98/ME/NT/2000/XP, the "**Faulhaber Motion Manager**" program is available; this considerably simplifies operation and configuration of the units via the CAN interface and also enables graphic online analysis of the operating data.

Once programmed as a speed or position controller via the analogue input, as a stepper motor or electronic gear, the drive can be operated independently of the RS232 interface.

### Fields of application

Thanks to the integrated technology, the drive can be used in many different areas with minimal wiring effort. The flexible connection options open up a broad field of application in all areas, for example in decentralised systems of automation technology, as well as in pick-and-place machines and machine tools.

### Options

An adapter board and serial null modem cable can also be ordered, to enable immediate commissioning of the 3564K024B CS.

Separate supply of motor and control electronics is possible (important for safety-relevant applications); in this case the 3rd input is not required.

Special preconfiguration of modes and parameters is possible on request.

The Motion Manager program is available on request or on the Internet.

### Note

Detailed operating instructions on installation and commissioning are provided with the brushless DC-Servomotor.

## Connection diagram

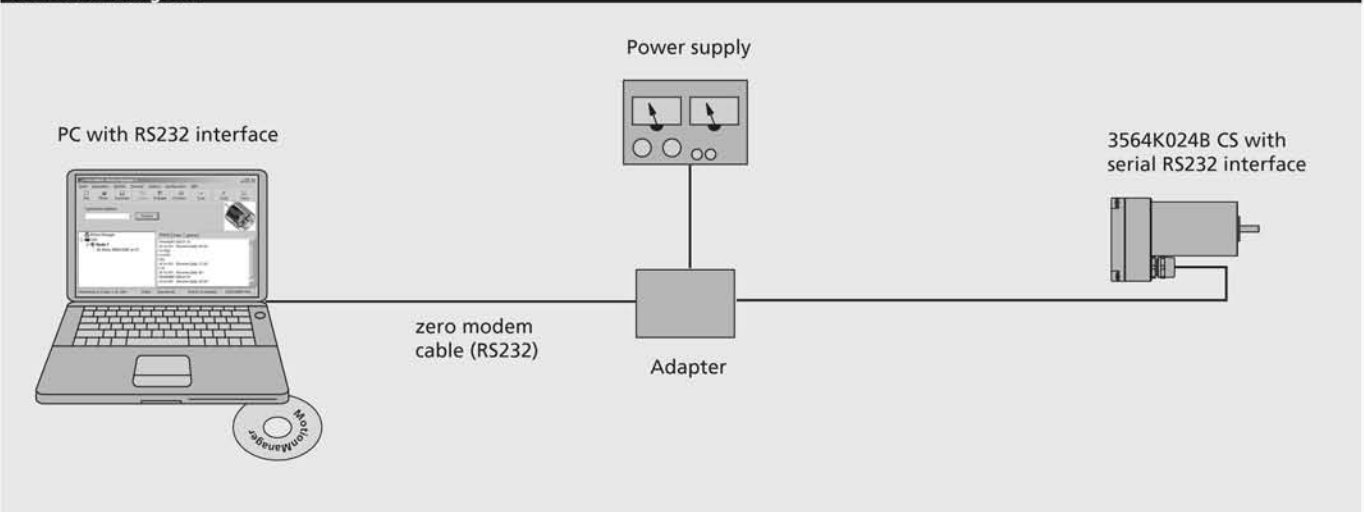

## Notes

---

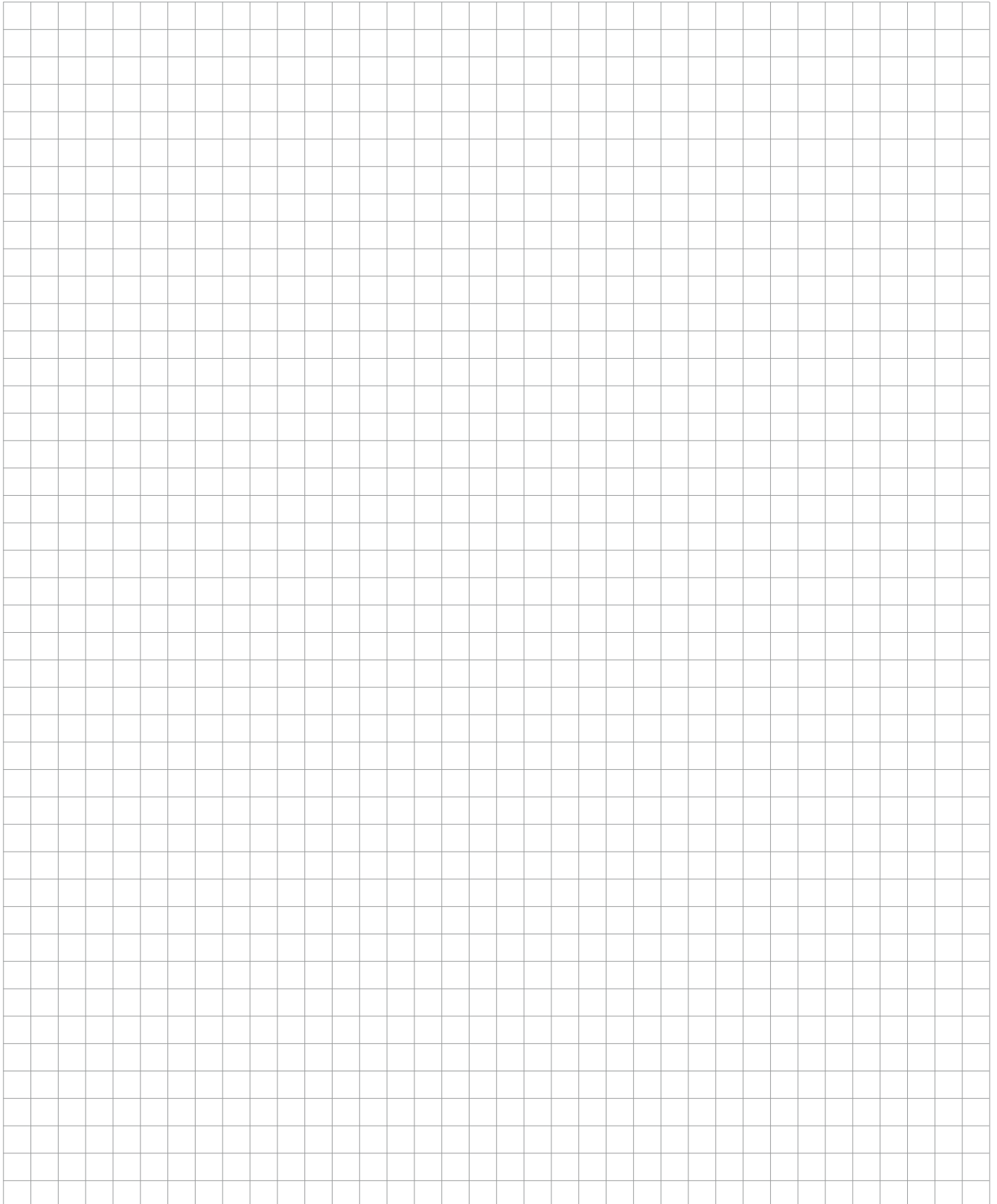



**NEW**

# Motion Controller

4-Quadrant PWM  
with RS232 interface

For combination with:  
Brushless DC-Servomotors  
with option K1155

## Series MCBL 3003/06 S

		MCBL 3003 S	MCBL 3006 S	
Power supply	U <sub>B</sub>	12 ... 30	12 ... 30	V DC
PWM switching frequency	f <sub>PWM</sub>	78,12	78,12	kHz
Efficiency	η	95	95	%
Max. continuous output current <sup>1)</sup>	I <sub>dauer</sub>	3	6	A
Max. peak output current	I <sub>max</sub>	10	10	A
Total standby current	I <sub>el</sub>	0,06	0,06	A
Speed range		5 ... 30 000	5 ... 30 000	rpm
Scanning rate	N	100	100	μs
Encoder resolution with Hall Sensors		≤ 3 000	≤ 3 000	lines/rev.
Resolution with external encoder		≤ 65 535	≤ 65 535	lines/rev.
Input/output (partially free configurable)		3	3	
Program memory:				
– memory size		3,3	3,3	kWord
– Number of instructions		ca. 1 000	ca. 1 000	intructions
Operating temperature range		0 ... + 70	0 ... + 70	°C
Storage temperature		– 25... + 85	– 25 ... + 85	°C
Housing material		without housing	aluminium, black anodized	
Weight		18	160	g

<sup>1)</sup> at 22°C ambient temperature

### Connection information

<b>Connection "TxD", "RxD":</b>				
Interface		RS232		
Communication profile		Faulhaber - ASCII		
Max. transfer speed rate		115 200		baud
<b>Connection "AGND":</b>				
– analog ground		analog GND		
– digital input	external encoder	channel B		
	R <sub>in</sub>	10		kΩ
	f	≤ 400		kHz
<b>Connection "Fault":</b>				
– digital input	R <sub>in</sub>	100		kΩ
– digital output (open collector)	U	≤ U <sub>B</sub>		V
	I	≤ 30		mA
	clear	switched to GND		
	set	high-impedance		
	fault output	switched to GND		
	no error	high-impedance		
	error	high-impedance		
	signal output	f	≤ 2	kHz
	resolution	1...255		lines/rev.
<b>Connection "AnIn":</b>			"AGND" as GND	
– analog input	set speed value	U <sub>in</sub>	± 10	V
– digital input	PWM set speed value	f	100 ... 2 000	Hz
	external encoder	T	50% ± 0 rpm	
			channel A	
		f	≤ 400	kHz
	step frequency input	f	≤ 400	kHz
		R <sub>in</sub>	5	kΩ
<b>Connection "+24V":</b>		U <sub>B</sub>	12 ... 30	V DC
<b>Connection "GND":</b>			ground	
<b>Connection "3. In":</b>				
– digital input	R <sub>in</sub>	22		kΩ
– electronic supply voltage <sup>2)</sup>	U <sub>B</sub>	12 ... 30		V DC

<sup>2)</sup> Optional on request

### Connection information

Connection "Ph A", "Ph B", "Ph C":					
Motor connection	Ph A		Phase A	brown <sup>1)</sup>	
	Ph B		Phase B	orange <sup>1)</sup>	
	Ph C		Phase C	yellow <sup>1)</sup>	
		$U_{out}$	$0 \dots U_B$		V
PWM switching frequency		$f_{PWM}$	7,8,12		kHz
Connection "Hall A", "Hall B", "Hall C":					
Hall sensor input	Hall A		Hall sensor A	green <sup>1)</sup>	
	Hall B		Hall sensor B	blue <sup>1)</sup>	
	Hall C		Hall sensor C	grey <sup>1)</sup>	
		$U_{in}$	$\leq 5$		V
Connection "SGND":					
Signal GND			Signal ground	black <sup>1)</sup>	
Connection "+5V":					
Output voltage for external use <sup>2)</sup>		$U_{out}$	5	red <sup>1)</sup>	V DC
Load current		$I_{out}$	$\leq 60$		mA

<sup>1)</sup> Color identification for brushless DC-Servomotor

<sup>2)</sup> E.g. Hall sensor

### D-SUB-connector information

Connection D-SUB-connector:			
Pin 2	RxD		RS232 / RxD
Pin 3	TxD		RS232 / TxD
Pin 5	GND		Ground

### Digital inputs general information

- PLC, default	high	$12,5 \dots U_B$	V
	low	$0 \dots 7$	V
- TTL	high	$3,5 \dots U_B$	V
	low	$0 \dots 0,5$	V

The signal level (PLC or TTL) of the digital inputs can be set over the interface (see instruction manual).

### Position control

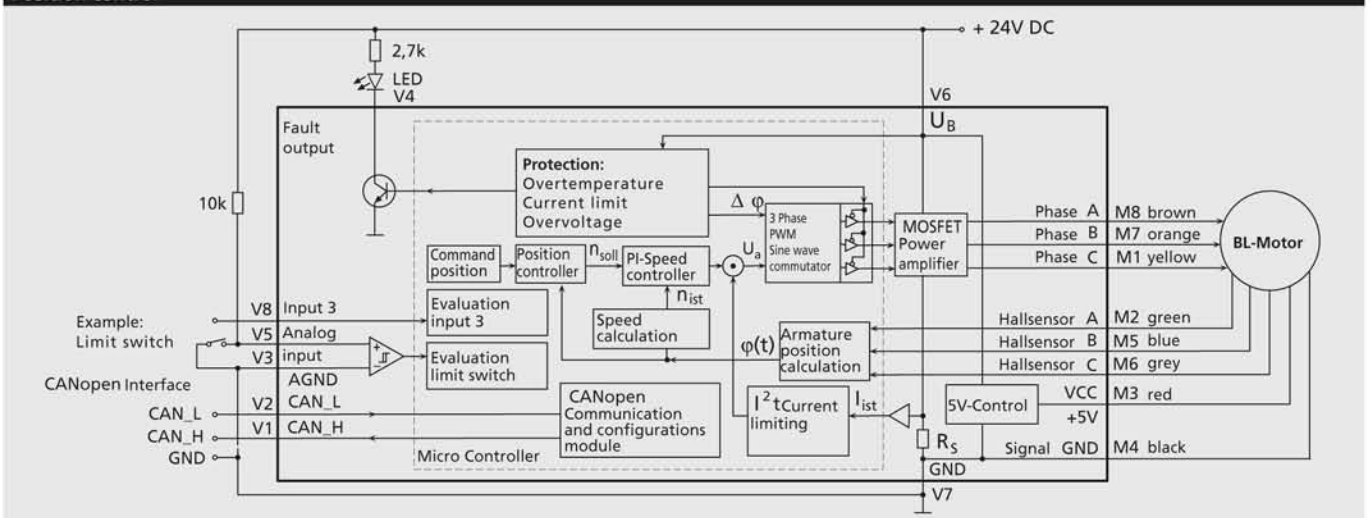

Specifications subject to change without notice

## Motion Controller

### General description

The MCBL 3003/06 S is designed for brushless DC-Servomotors with linear Hall sensors. Ultra-low speeds and high positioning resolutions (1/3000 revolutions) are thus possible without the need for an additional encoder. The motors have a sinusoidal current, resulting in a constant torque over the entire circumference. This means that the motors run particularly quietly, and efficiency is also increased.

### Maximum performance:

- **PI speed controller** with superior performance specifications in respect of synchronous operation and minimal torque fluctuations.
- **Speed profiles** such as e.g. ramp, triangular or trapezoidal movements. More complex profiles can also be implemented.
- **Positioning** with high resolution, including **limit switches and zero referencing**.
- **Operation as torque controller** through current regulation.
- **Storage** and execution of motion programs for stand-alone positioning mode or to relieve the HOST computer.
- **Extended operating modes:**
  - Stepper motor mode
  - Gearing mode (electronic gear)
  - Analogue positioning mode (position control with analogue voltage)
  - Voltage regulator mode
  - Analogue target current presetting
  - External encoder as absolute encoder

### Latest technology in micro format:

- High efficiency
- Power amplifier with very high PWM frequency
- Power MOSFETs with minimal on-resistance
- Unique thermal protection device determines MOSFET silicon temperature
- High-capacity 16 bit signal processor

### Versatile communication:

- **Set-point input** for speed presetting. Processes analogue and PWM signals. The input can also be used for a frequency or reference mark signal.
- **Error output** (Open Collector). Can also be programmed as a rotational direction or reference mark input.
- **Additional digital input**
- **RS232 interface** for connection to PC or control
- Operation of several drives on a single RS232 interface (Multiplex mode)

### Programming made easy

An extensive ASCII command set is available for programming and operation. This can be preset from the PC, e.g. via any terminal program or via any other control computer.

Once programmed as a stepper motor, electronic gear or as speed / position controller via the analogue input, the drive can be operated independently of the RS-232 interface.

For Windows operating systems the "FAULHABER Motion Manager" software is available. This considerably simplifies operation and configuration and also enables graphic online analysis of the operating data.

### Fields of application

The Motion Controller can be used in many different areas. Thanks to the highly flexible connection options, this device is suitable for a diverse range of applications, for example in decentralised systems of automation technology, as well as in pick-and-place machines and machine tools.

### Options

- Serial null modem cable for RS232 interface
- Separate supply of motor and control electronics is optionally possible (important for safety-relevant applications); in this case the 3rd input is not required.
- Special preconfiguration of modes and parameters is possible on request.
- The "FAULHABER Motion Manager" software is available on request or on the Internet.

### Note

Detailed operating instructions on installation and commissioning are provided with the Motion Controller.

## Connection diagram

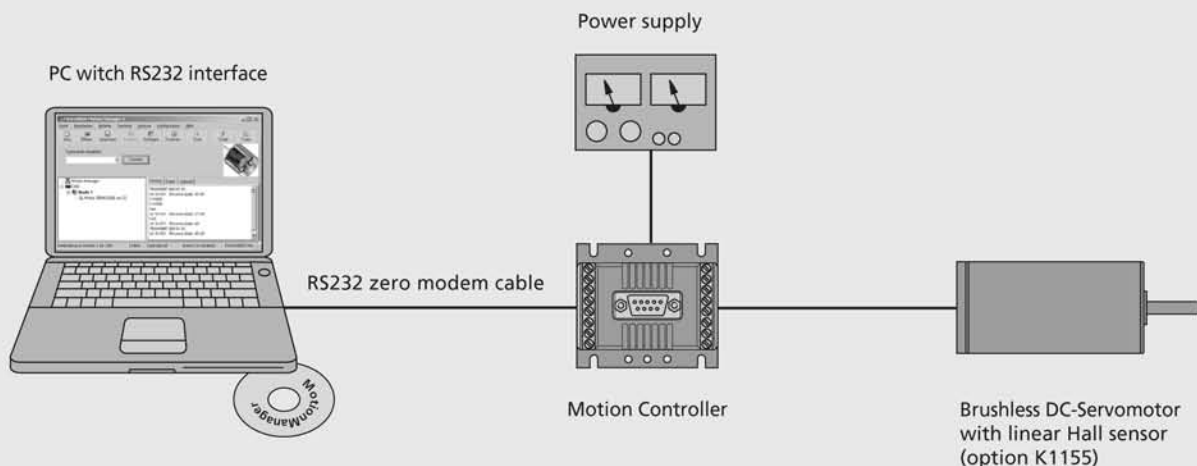

### Dimensional drawing and connection information MCBL 3003 S

Scale reduced

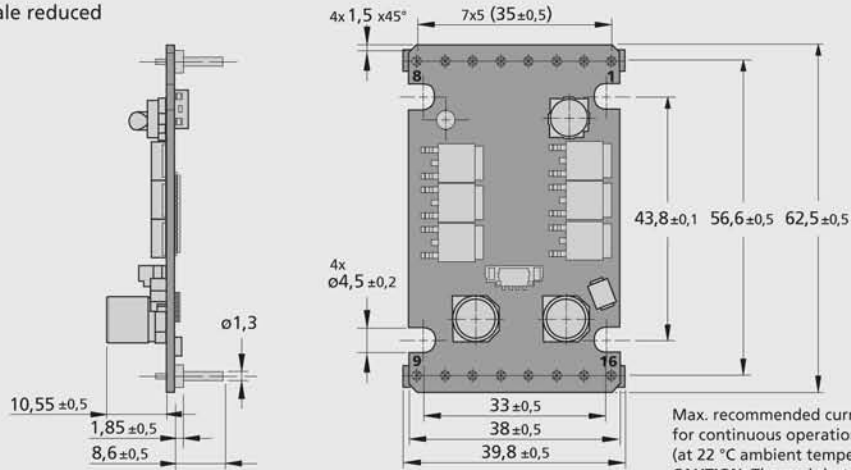

Max. recommended current for continuous operation: 3A (at 22 °C ambient temperature)  
CAUTION: Thermal shutdown is NOT guaranteed!

#### Connection

Pin	Function
1	Ph C
2	Hall A
3	+ 5V
4	SGND
5	Hall B
6	Hall C
7	Ph B
8	Ph A
9	TxD
10	RxD
11	AGND
12	Fault
13	AnIn
14	+ 24V
15	GND
16	3. In

### Dimensional drawing and connection information MCBL 3006 S

Scale reduced

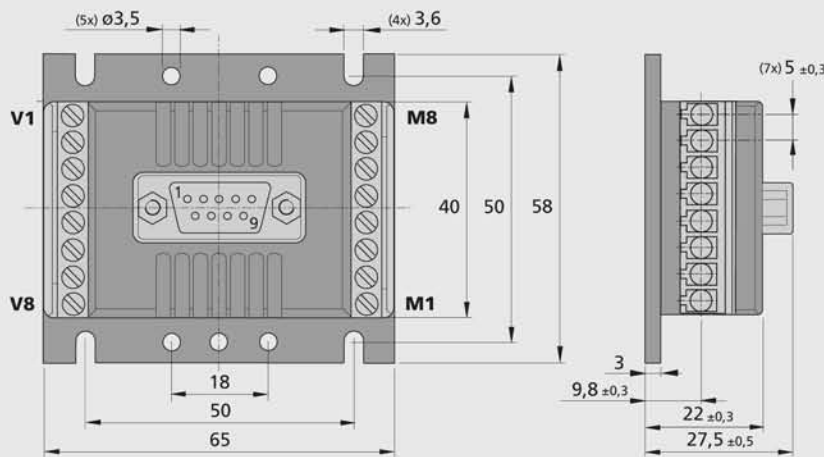

#### Motor connection

No.	Function
M1	Ph C
M2	Hall A
M3	+ 5V
M4	SGND
M5	Hall B
M6	Hall C
M7	Ph B
M8	Ph A

#### Supply connection

No.	Function
V1	TxD
V2	RxD
V3	AGND
V4	Fault
V5	AnIn
V6	+ 24V
V7	GND
V8	3. In

**NEW**

# Motion Controller

4-Quadrant PWM  
with RS232 interface

For combination with:  
DC-Micromotors

## Series MCDC 3003/06 S

		MCDC 3003 S	MCDC 3006 S	
Power supply	U <sub>B</sub>	12 ... 30	12 ... 30	V DC
PWM switching frequency	f <sub>PWM</sub>	78,12	78,12	kHz
Efficiency	η	95	95	%
Max. continuous output current <sup>1)</sup>	I <sub>dauer</sub>	3	6	A
Max. peak output current	I <sub>max</sub>	10	10	A
Total standby current	I <sub>el</sub>	0,06	0,06	A
Speed range		5 ... 30 000	5 ... 30 000	rpm
Scanning rate	N	100	100	μs
Encoder resolution with Hall Sensors		≤ 65 535	≤ 65 535	lines/rev.
Input/output (partially free configurable)		5	5	
Program memory:				
– memory size		3,3	3,3	kWord
– Number of instructions		ca. 1 000	ca. 1 000	intructions
Operating temperature range		0 ... + 70	0 ... + 70	°C
Storage temperature		– 25... + 85	– 25 ... + 85	°C
Housing material		without housing	aluminium, black anodized	
Weight		18	160	g

<sup>1)</sup> at 22°C ambient temperature

### Connection information

<b>Connection "TxD", "RxD":</b>				
Interface		RS232		
Communication profile		Faulhaber - ASCII		
Max. transfer speed rate		115 200		baud
<b>Connection "AGND":</b>				
– analog ground		analog GND		
– digital input	external encoder	channel B		
	R <sub>In</sub>	10		kΩ
	f	≤ 400		kHz
<b>Connection "Fault":</b>				
– digital input		channel B		
– digital output (open collector)		100		kΩ
	U	≤ U <sub>B</sub>		V
	I	≤ 30		mA
	clear	switched to GND		
	set	high-impedance		
	no error	switched to GND		
	error	high-impedance		
<b>Connection "AnIn":</b>				
– analog input	set speed value	"AGND" as GND		
	U <sub>In</sub>	± 10		V
– digital input	PWM set speed value	100 ... 2 000		Hz
	T	50% ± 0 rpm		
	external encoder	channel A		
	f	≤ 400		kHz
	step frequency input	≤ 400		kHz
	R <sub>In</sub>	5		kΩ
<b>Connection "+24V":</b>				
	U <sub>B</sub>	12 ... 30		V DC
<b>Connection "GND":</b>				
		ground		
<b>Connection "3. In":</b>				
– digital input		22		kΩ
– electronic supply voltage <sup>2)</sup>	U <sub>B</sub>	12 ... 30		V DC
<b>Connection "4. In":</b>				
– digital input		22		kΩ
<b>Connection "5. In":</b>				
– digital input		22		kΩ

<sup>2)</sup> Optional on request

### Connection information

Connection "Mot -", "Mot +":				
Motor connection	Mot - Mot +		Motor - Motor +	
PWM switching frequency		$U_{out}$ $f_{PWM}$	0 ... $U_B$ 78,12	V kHz
Connection "Ch A", "Ch B":				
Hall sensor input	CH A CH B		encoder channel A encoder channel B	
Integrated pullup resistance + 5V		R f	2,2 $\leq 400$	k $\Omega$ kHz
Connection "SGND":				
Signal GND			signal ground	
Connection "+5V":				
Output voltage for external use <sup>1)</sup>		$U_{out}$	5	V DC
Load current		$I_{out}$	$\leq 60$	mA

<sup>1)</sup> E.g. encoder

### D-SUB-connector information

Connection D-SUB-connector:				
Pin 2	RxD		RS232 / RxD	
Pin 3	TxD		RS232 / TxD	
Pin 5	GND		Ground	

### Digital inputs general information

- PLC, default	high	12,5 ... $U_B$	V
	low	0 ... 7	V
- TTL	high	3,5 ... $U_B$	V
	low	0 ... 0,5	V

The signal level (PLC or TTL) of the digital inputs can be set over the interface (see instruction manual).

### Position control

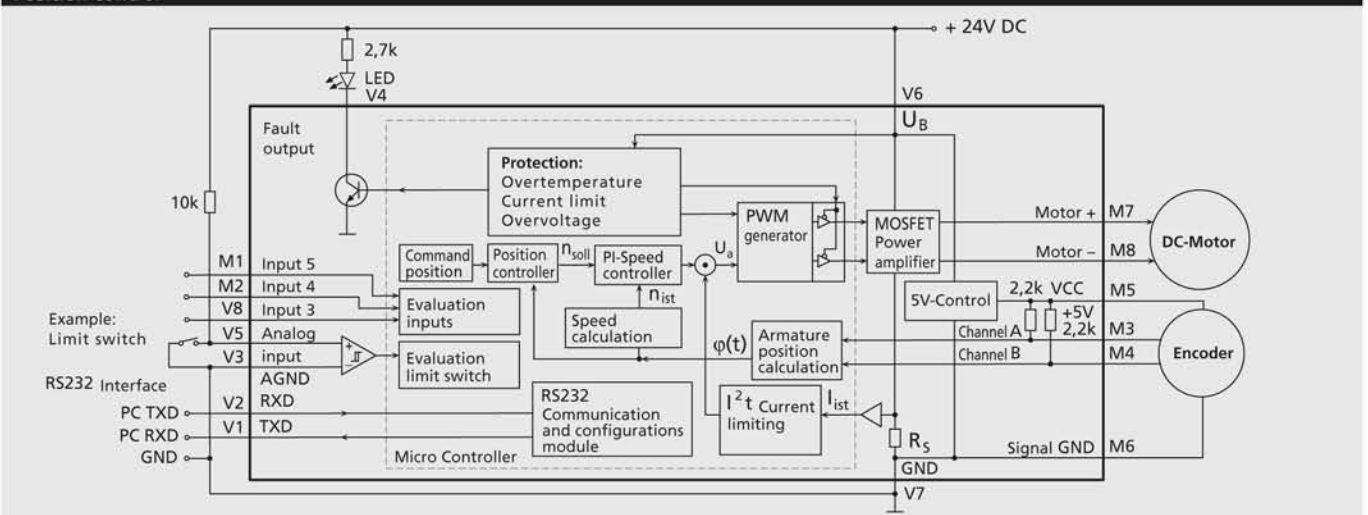

Specifications subject to change without notice

## Motion Controller

### General description

The MCDC 3003/06 S is the perfect controller for the entire range of FAULHABER DC-Micromotors. In conjunction with the proven IE2-512 encoders, they are capable of achieving a positioning resolution of 0.18°. A special ballast circuit protects the electronics from over-voltage during braking in generator mode.

### Maximum performance:

- **PI speed controller** with superior performance specifications in respect of synchronous operation and minimal torque fluctuations.
- **Speed profiles** such as e.g. ramp, triangular or trapezoidal movements. More complex profiles can also be implemented.
- **Positioning** with high resolution, including **limit switches and zero referencing**.
- **Operation as torque controller** through current regulation.
- **Storage** and execution of motion programs for stand-alone positioning mode or to relieve the HOST computer.
- **Extended operating modes:**
  - Stepper motor mode
  - Gearing mode (electronic gear)
  - Analogue positioning mode (position control with analogue voltage)
  - Voltage regulator mode
  - Analogue target current presetting
  - IxR control

### Latest technology in micro format:

- High efficiency
- Power amplifier with very high PWM frequency
- Power MOSFETs with minimal on-resistance
- Unique thermal protection device determines MOSFET silicon temperature
- High-capacity 16 bit signal processor

### Versatile communication:

- **Set-point input** for speed presetting. Processes analogue and PWM signals. The input can also be used for a frequency or reference mark signal.
- **Error output** (Open Collector). Can also be programmed as a rotational direction or reference mark input.
- **Additional digital inputs**
- **RS232 interface** for connection to PC or control
- Operation of several drives on a single RS232 interface (Multiplex mode)

### Programming made easy

An extensive ASCII command set is available for programming and operation. This can be preset from the PC, e.g. via any terminal program or via any other control computer.

Once programmed as a stepper motor, electronic gear or as speed / position controller via the analogue input, the drive can be operated independently of the RS232 interface.

For Windows operating systems the "FAULHABER Motion Manager" software is available. This considerably simplifies operation and configuration and also enables graphic online analysis of the operating data.

### Fields of application

The Motion Controller can be used in many different areas. Thanks to the highly flexible connection options, this device is suitable for a diverse range of applications, for example in decentralised systems of automation technology, as well as in pick-and-place machines and machine tools.

### Options

- Adapter for IE2 or HEDL encoder
- Serial null modem cable for RS232 interface
- Separate supply of motor and control electronics is optionally possible (important for safety-relevant applications); in this case the 3rd input is not required.
- Special preconfiguration of modes and parameters is possible on request.
- The "FAULHABER Motion Manager" software is available on request or on the Internet.

### Note

Detailed operating instructions on installation and commissioning are provided with the Motion Controller.

## Connection diagram

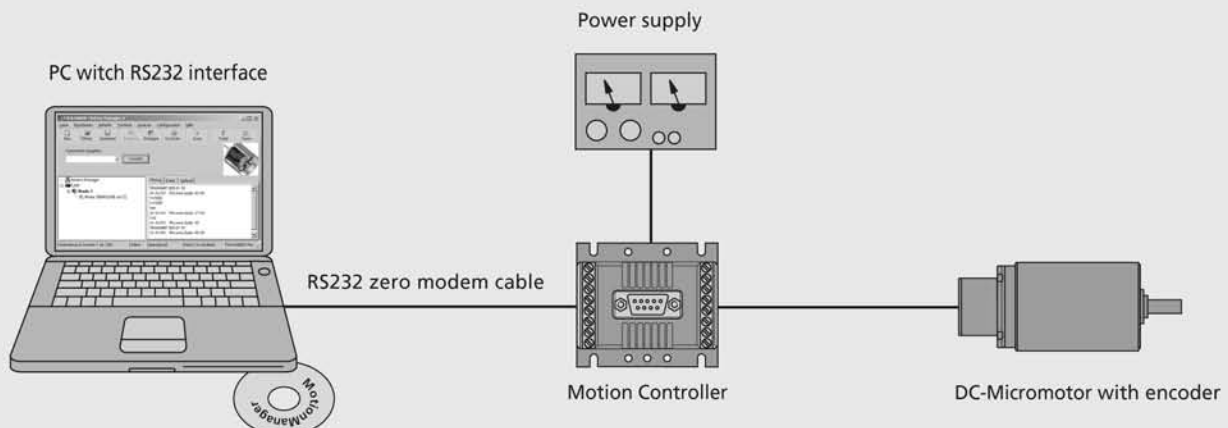

**Dimensional drawing and connection information MCDC 3003 S**

Scale reduced

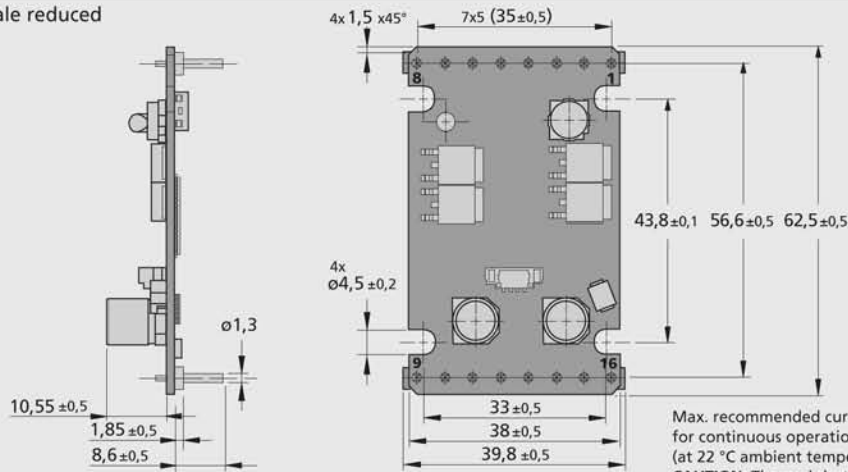

Max. recommended current  
 for continuous operation: 3A  
 (at 22 °C ambient temperature)  
**CAUTION:** Thermal shutdown is  
 NOT guaranteed!

**Connection**

Pin	Function
1	5. In
2	4. In
3	Ch A
4	Ch B
5	+5V
6	SGND
7	Mot +
8	Mot -
9	TxD
10	RxD
11	AGND
12	Fault
13	AnIn
14	+24V
15	GND
16	3. In

**Dimensional drawing and connection information MCDC 3006 S**

Scale reduced

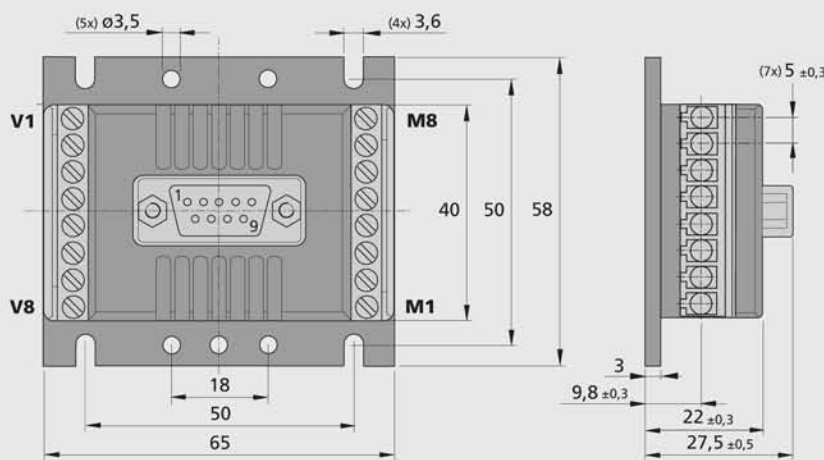
**Motor connection**

No.	Function
M1	5. In
M2	4. In
M3	Ch A
M4	Ch B
M5	+5V
M6	SGND
M7	Mot +
M8	Mot -

**Supply connection**

No.	Function
V1	TxD
V2	RxD
V3	AGND
V4	Fault
V5	AnIn
V6	+24V
V7	GND
V8	3. In



## Notes

---

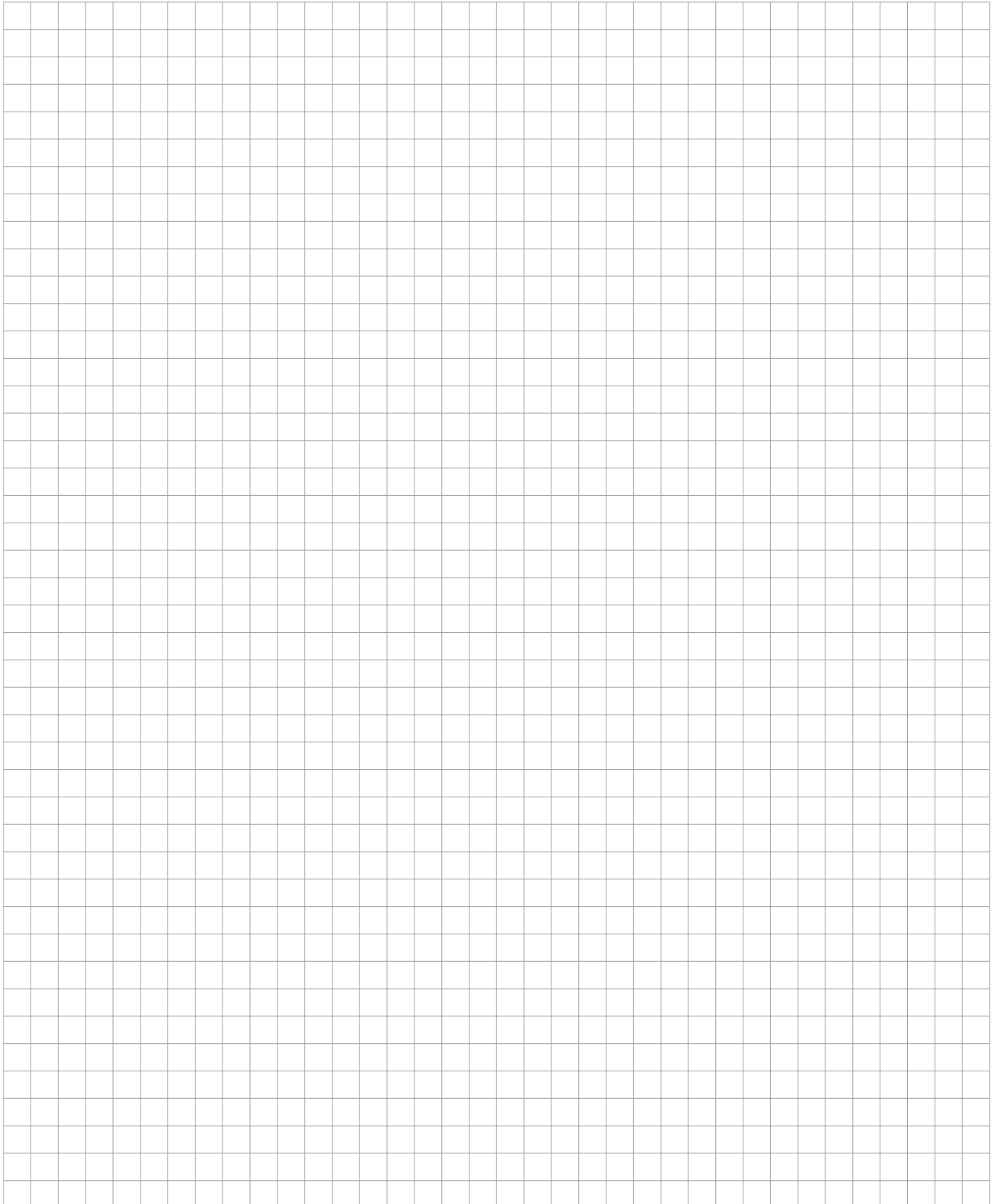

The FAULHABER Group

**DR. FRITZ FAULHABER  
GMBH & CO. KG**

Daimlerstraße 23  
71101 Schönaich · Germany  
Tel.: +49(0)70 31/638-0  
Fax: +49(0)70 31/638-100  
Email: info@faulhaber.de  
www.faulhaber-group.com

**MINIMOTOR SA**

6980 Croglio · Switzerland  
Tel.: +41(0)916113100  
Fax: +41(0)916113110  
Email: info@minimotor.ch  
www.minimotor.ch

**MicroMo Electronics, Inc.**

14881 Evergreen Avenue  
Clearwater  
FL 33762-3008 · USA  
Phone: +1(727) 572-0131  
Fax: +1(727) 573-5918  
Toll-Free: (800) 807-9166  
Email: info@micromo.com  
www.micromo.com



[www.faulhaber-group.com](http://www.faulhaber-group.com)



**More information? Go online!**

Feel free to browse through the latest product highlights, inspirational application reports, interesting press information and order our catalogues and documentations easily and conveniently at the click of a mouse button.

