

HEAD-WORN MICROPHONE WITH RECEIVER



GENERAL

The Shure Model SM12A Professional Head-Worn Microphone with Receiver is a low-impedance, unidirectional, dynamic microphone with an integral earphone assembly. The SM12A offers convenient, hands-free operation for sports and news announcing, interviewing and intercommunication systems, and for special events remote broadcasting. A close-talking unit, the SM12A can be used under noisy conditions without loss or masking of voice signals. The SM12A and the supplied dual-spring steel headband is rugged and reliable. A miniature windscreen to protect against wind noise and explosive breath sounds and two connector belt clips are also supplied.

Features:

- Close-talk operation and unidirectional polar pattern for effective noise reduction
- Smooth natural voice frequency response
- Locking adjustment knob permits boom to pivot 20° in any direction
- Boom length adjustment through 89 mm (3 1/2 in.) range
- Built-in receiver protection circuit automatically avoids excessive sound pressure level
- Receiver ear tube adjustable through 55° arc
- Light weight plus dual headband eliminate user fatigue
- Does not interfere with eyeglasses
- Ruggedly constructed of stainless steel, aluminum and high-impact thermoplastic
- Convenient, secure clips attach connectors to belt or clothing

RIGHT SIDE OPERATION

As supplied, the microphone is positioned on the left side, as shown in Figure 1. For right side usage (see photo), remove the retaining clip and attach it to the other (unused) hole in the headband arm so the screw is at the top.

CLEANING THE RECEIVER TIP

A decrease in receiver output may be due to clogging of the receiver tip. The tip may be cleaned by removing it from the ear tube and inserting a toothpick or similar device through the tip hole. If clogging is apparent in the ear tube, carefully remove the obstruction from the ear tube tip.

CAUTION: Do not disturb the foam damping material located just inside the ear tube tip.

WARNING

Sustained high volume levels in conjunction with a tightly fitting receiver tip may adversely affect the user's hearing. Make certain the volume is set to a comfortable listening level and position the receiver tip at the entrance of the ear.

ASSEMBLY

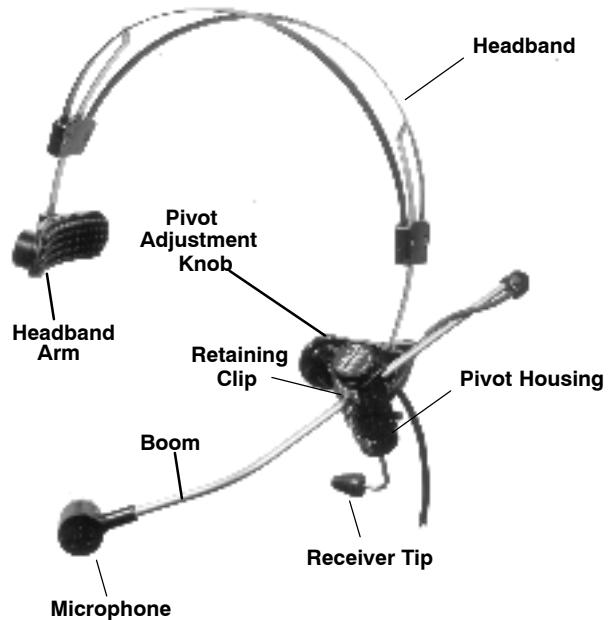

SM12A POSITIONED FOR LEFT SIDE OPERATION
FIGURE 1

1. Position the lower headband arms perpendicular to the headband.
2. Snap the microphone pivot housing into the retaining clip with the pivot adjustment knob upward and the microphone toward the front.

3. Loosen the pivot adjustment knob, position the boom so that the microphone is near where the side of the mouth will be, and tighten the pivot adjustment knob.
4. Place the assembled microphone on the user's head and pull the headband arms downward until they rest against the head just over the ears. Position the receiver tip at the entrance to the ear. (Make certain cable is free of receiver ear tube.)
5. Loosen the pivot adjustment knob and position the microphone as close as possible to the corner of the mouth. For optimum close-talking operation, the microphone should be less than 25 mm (1 in.) from the corner of the mouth. Be sure to position the microphone at the corner (not the center) of the mouth to eliminate explosive breath sounds ("pop"). Tighten the adjustment knob.
- 6.. Snap the microphone connector belt clip over the groove in the 3-pin audio connector and the receiver connector belt clip over the groove in the phone plug. The clips can now be fastened to the user's belt or other clothing. Attach the 3-pin audio connector to the microphone cable and the phone plug to the monitoring unit cable.

MICROPHONE SPECIFICATIONS

TYPE

Dynamic, Close-Talking

FREQUENCY RESPONSE: At 8 mm (5/16 in.)

50 to 15,000 Hz (see Figure 2)

POLAR PATTERN

Cardioid (unidirectional) response-uniform with frequency, symmetrical about axis (see Figure 3)

Impedance

Microphone rating impedance is 150 ohms (200 ohms actual) for connection to microphone inputs rated at 19 to 300 ohms

Sensitivity (close-talked at 1,000 Hz)

Open Circuit Voltage -67.0 dBV/Pa (.45 mV)
 (1 Pa = 94 dB SPL)

Hum Sensitivity (typical)

38.4 dB equivalent SPL in a 1 millioersted field

Phasing

Positive pressure on diaphragm produces positive voltage on pin 2 of microphone connector

Connector

Male XLR audio connector (TA3M)

Receiver

Type

Dynamic

Frequency Response

70 to 12,000 Hz

Impedance

2,000 ohms at 1 kHz (200-ohms cartridge with matching transformer in phone plug)

Output Level

105 dB SPL with 1.4V at 1 kHz (1.0 mW into 2 cc cavity)

Phasing

Positive voltage on phone plug tip produces positive pressure in ear tube

Connector

Phone plug (contains matching 200:2,000 ohm transformer)

GENERAL SPECIFICATIONS

Cable

Non-detachable, 1.5m (5 ft), four conductor, shielded, plastic-jacketed; additional 762 mm (2.5 ft), two-conductor receiver cable attached to microphone connector.

Case

Black thermoplastic microphone and pivot housing, anodized aluminum end caps, stainless steel grille, ear tube and boom

Dimensions

See Figure 4

Net Weight

84 grams (3 ounces) less cable and connectors

Packaged Weight

978 grams (2 lb, 2 1/2 oz)

CERTIFICATION

Eligible to bear CE Marking. Conforms to European EMC Directive 89/336/EEC. Meets applicable tests and performance criteria in European Standard EN55103 (1996) parts 1 and 2, for residential (E1) and light industrial (E2) environments.

ACCESSORIES AND REPLACEMENT PARTS

The following furnished accessories and replacement parts may be ordered through your Authorized Shure Professional Products Dealer or from Shure Incorporated.

Connector Belt Clip	RK200BC
Windscreen	RK 184WS
Carrying Case	90DJ2600
Microphone Cartridge	R93
Receiver Cartridge	90EL2600
Headband Assembly	RK352
Receiver Tip	90FS2600

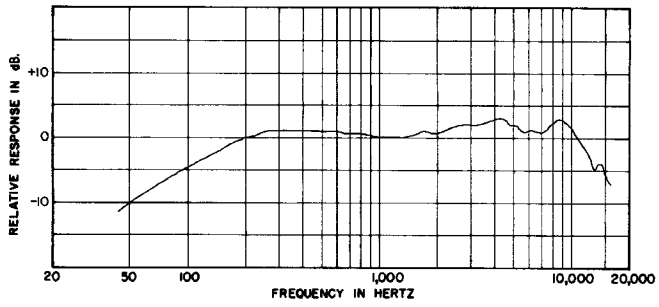

TYPICAL MICROPHONE FREQUENCY RESPONSE
FIGURE 2

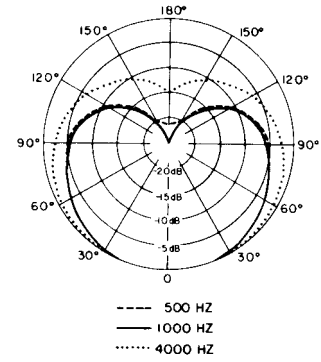

TYPICAL POLAR PATTERN
FIGURE 3

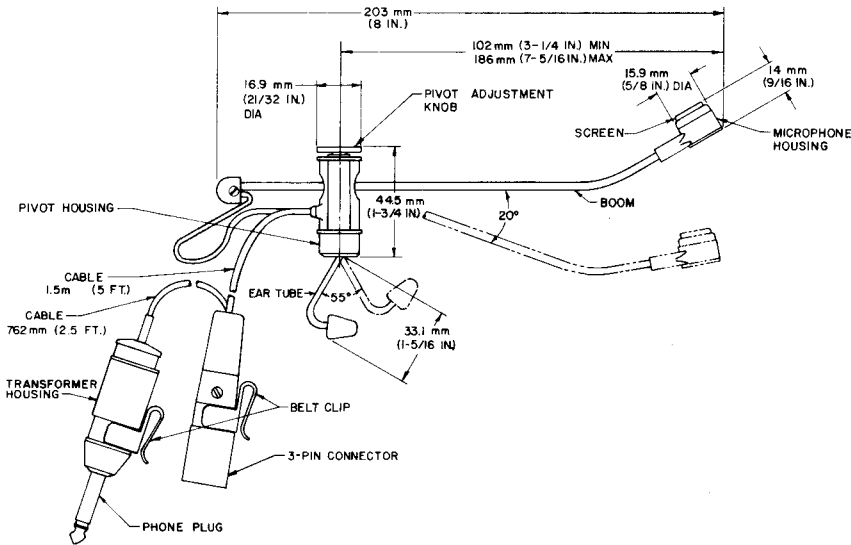

OVERALL DIMENSIONS
FIGURE 4

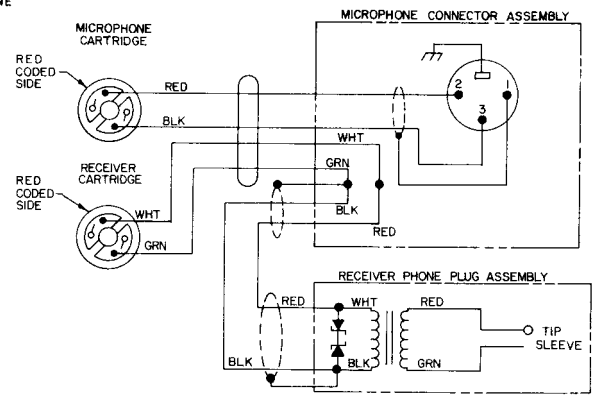

INTERNAL CONNECTIONS
FIGURE 5

EARPHONE VOLUME CONTROL

A simple volume control circuit can be built to enable the SM12A earphone receiver to be connected to the speaker output of a power amplifier with an output of up to 200 watts into 4 ohms. (The volume control need not be connected directly to the power amplifier. It can also be connected to an unused phone jack on a working stage monitor.)

WARNING

Although the SM12A's receiver circuit is protected against excessive level, it is capable of an output of over 121 dB SPL sufficient to cause hearing damage with prolonged exposure. Always take care to turn the volume control on this circuit all the way down before inserting the earpiece into your ear. Then turn the control up gradually until a comfortable listening level is reached.

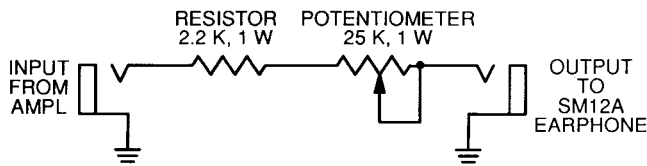

VOLUME CONTROL
FIGURE 6

PARTS LIST

2	Two-circuit phone jacks
1	Resistor, 2.2k, 1W
1	Potentiometer, 25k, 1W (or larger)
1	Plastic or metal box
.....	Connecting leads

ARCHITECT'S SPECIFICATIONS

The microphone with receiver shall be the Shure Model SM12A or equivalent. The microphone shall be a moving-coil (dynamic) type with a frequency response of 50 to 15,000 Hz. The unit shall have a cardioid polar characteristic. The cancellation at the rear shall be 15 to 20 dB. The microphone shall be low impedance with a rated impedance of 150 ohms for connection to microphone inputs rated at 19 to 300 ohms.

The microphone output shall be - 66.0 dB where 0 dB = 1 milliwatt per 10 microbars.

The receiver shall be a dynamic type with a frequency response of 70 to 12,000 Hz. The receiver shall be supplied with an integral connector-mounted matching transformer designed with an impedance of 2,000 ohms.

The microphone with receiver shall be a head-worn type, and shall be provided with a 1.5m (5 ft), non-detachable, four-conductor (two-conductor shielded) cable with a professional three-pin audio connector designed to mate with Cannon XL series, 3-Pin Mini Connector (TA3M) or equivalent connectors. An additional 762 mm (2.5 ft) cable length shall be provided between microphone and receiver (phone plug) connectors. The microphone shall also be provided with a headband, two connector belt clips, and a foam wind-screen.

The overall dimensions of the microphone shall be 203 mm (8 in.) in length and 44.5 mm (1-3/4 in.) in maximum height (pivot housing). The microphone housing shall be 15.9 mm (5/8 in.) in diameter and 14 mm (9/16 in.) in height.

SHURE

SHURE Incorporated Web Address: <http://www.shure.com>
 222 Hartrey Avenue, Evanston, IL 60202-3696, U.S.A.
 Phone: 847-866-2200 Fax: 847-866-2279
 In Europe, Phone: 49-7131-72140 Fax: 49-7131-721414
 In Asia, Phone: 852-2893-4290 Fax: 852-2893-4055
 Elsewhere, Phone: 847-866-2200 Fax: 847-866-2585