



**Scotsman**®

Ice Systems

**MC 16 – MC 46**

**MF 56 –MFE 61 - MF 83**

**MV 450 – MV 600**

**MV 800 - MV 1000**

**REMOTE AIR COOLED  
CONDENSER**

**SERVICE MANUAL**

## HORIZONTAL INSTALLATION (RECOMMENDED)

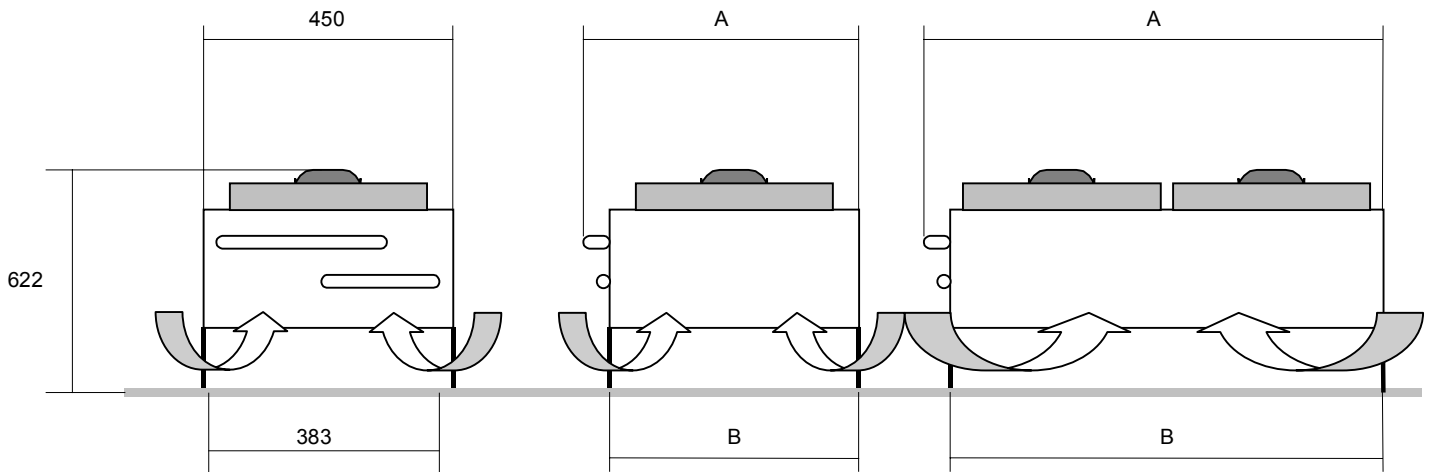

## VERTICAL INSTALLATION

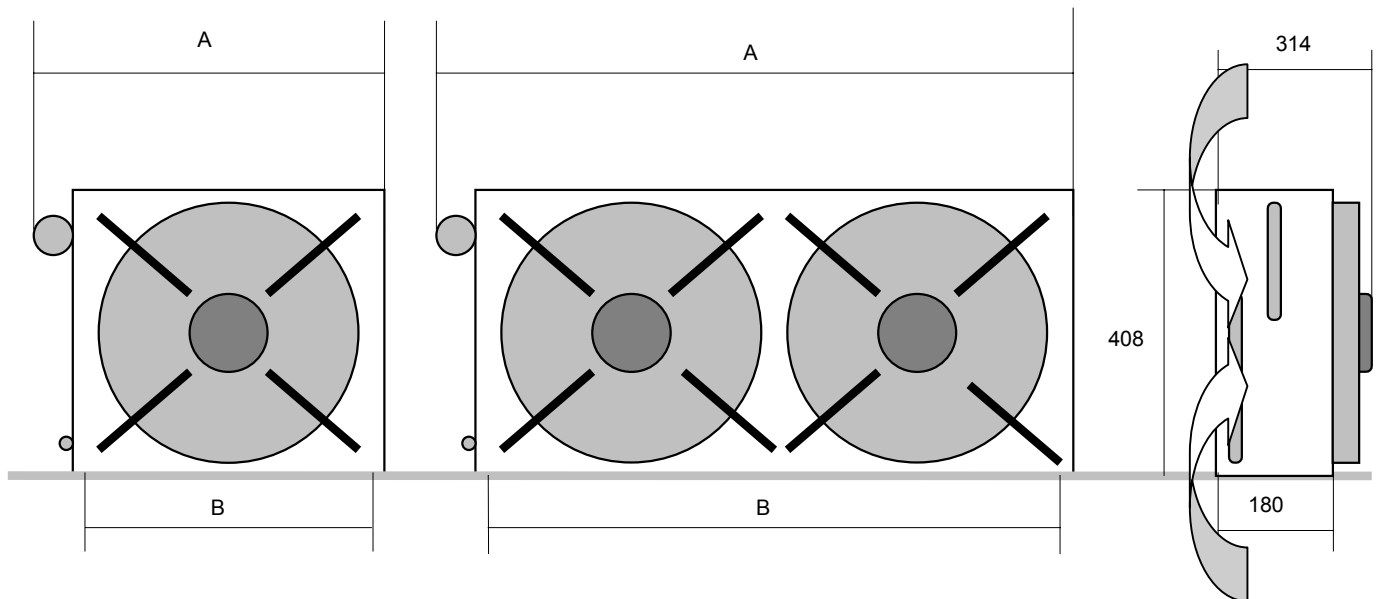

	1 FAN MOTOR	2 FAN MOTORS	3 FAN MOTORS
A mm	560	1340	1980
B mm	439	1139	1779

## WEATHER PROOF AIR COOLED REMOTE CONDENSER

The remote condenser versions of Cubers and Flakers are similar to the air cooled standard versions with the only difference of the remote condenser and, on MC and MF series, of the Fan Speed Control used to supply power to the fan motor/s.

### Technical specifications

1. Remote air cooled condenser fit on proper brackets for horizontal and vertical installation (MV series for vertical installation only).  
Cooling capacity with  $\Delta T$  15K is 3750 Kcal/hr on MC 16, MC 46 and MF 56 and on MV 450, MV 600 and MV 1000 old style; 9000 Kcal/hr on MFE 61; 17700 Kcal/hr on MF 83.
2. Fan motor/s 220-240/50-60/1 - 135 Watts - 0,6 Amps with IP 44 protection (against liquids and solids) and flow rate of 2150 m<sup>3</sup>/hr (2 motors on MFE 61; 3 motors on MF 83).
3. On MC and MF series only, an Electronic Fan Speed Control set to 16 bar. On MV series a standard ON-OFF hi pressure control (15÷17 bars).
4. Pre-charged refrigerant lines of 10 meters length equipped with AEROQUIP quick connections.
5. Hi pressure safety control (manual reset type) set to 34 bar on MC and MF series (in place of the condenser temperature sensor) and to 30 bar on MV series.
6. Hi pressure control warning light.

## Installation of the remote air cooled condenser and pre-charged refrigerant lines

### A. Location considerations:

Select the best available place protected from dirt/dust.

The weather proof remote air cooled condenser can be installed indoor as well as outdoor and can operate under the most different conditions (rain, wind, snow, etc.)

Use the following formula for planning the location of the condenser and ice machine.

### Location Limits – Condenser location must not exceed ANY of the following limits

Maximum vertical drop **dd** of 1 meter between the icemaker and the remote condenser.

Maximum vertical rise **rd** of 3 meters.

Physical line set maximum length between icemaker and remote condenser is 10 meters.

### Limit to max. one rise and one drop.

Limit the **calculated distance (CD)** as per the Calculation formula to 18 meters.

$$A = \text{Drop} = dd \times 6.6$$

$$B = \text{Rise} = rd \times 1.7$$

$$C = \text{Horizontal run} = hd \times 1$$

$$CD = A + B + C$$

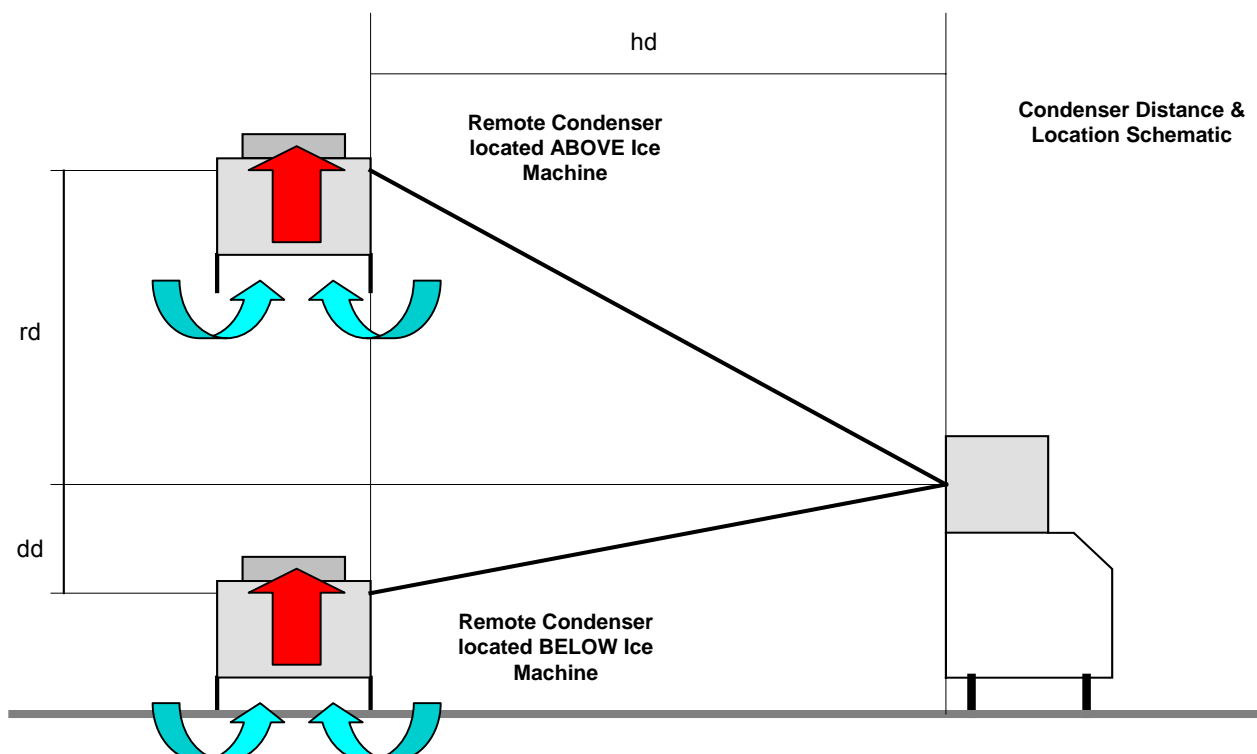

B. Unpacking and inspection:

Visually inspect the exterior of the shipping container; any severe damage should be reported to the delivery carrier.

Uncrate the remote condenser and pre-charged refrigerant lines and inspect for any concealed damage. Notify carrier of any concealed damage. Check that the pre-charged refrigerant lines are intact, not kinked.

C. Remote condenser installation

Install and attach the remote condenser to the floor or to the wall of the building using methods and practices conform to the local building requirements.

Remove the control box cover from the remote condenser and connect the electrical power line coming from the unit following the wires colors.

**NOTE.** Cable connecting the unit to the remote condenser is at 230 Volts so it is **imperative** to have the cable properly protected inside a plastic or metal tube according to the local electrical code/standard.

D. Pre-charged refrigerant lines

The set of pre-charged refrigerant lines consists of the 3/8" O.D. self sealing gas line and 1/4" O.D. self sealing liquid line both equipped with 1-20" UNEF AEROQUIP quick connections on MC 16-46, MF 56, of 12 mm and 8 mm O.D. on MV 450-600 and 14 mm and 12 mm O.D. on MV 800-1000.

On models MFE 61 the pre-charged refrigerant lines are 1/2" O.D. gas line and 3/8" O.D. liquid line both equipped with 1-20" UNEF AEROQUIP quick connections.

On model MF 83 only, 16 mm O.D. gas line and 12 mm O.D. liquid line with AEROQUIP quick connections too.

Whenever the length of the pre-charged refrigerant lines are longer then the distance between the ice maker and the remote condenser

keep the excess portion indoor shaped as a vertical spiral so to avoid refrigerant trapping.

**CAUTION. Each coupling on the pre-charged refrigerant lines is self-sealed and should be tightened 1/4 turn more then snug tight. ALWAYS USE TWO WRANCHES WHEN TIGHTENING THESE FITTINGS, ONE AS BACKUP WRENCH TO PREVENT TWISTING OF TUBING AND POSSIBLE KINKING OR LINE RUPTURE.**

Connect the gas line coupling to the remote condenser refrigerant fitting (labeled GAS) and to the refrigerant fitting on the rear side of the ice machine.

Connect the liquid line coupling to the remote condenser refrigerant fitting (labeled LIQUID) and to the refrigerant fitting on the rear side of the ice machine.

**ATTENTION. The inlet of the remote air cooled condenser (gas) must be always located above the outlet (liquid) for both horizontal and vertical installations.**

**Operating instructions**

The remote air cooled condenser versions of Cubers and Flakers are operating in the same way as the standard machine.

The only difference is the operation of the fan motor on MC and MF series as on the remote condenser versions it is no longer possible to use the condenser sensor to control the ON-OFF operation of the same.

In place of the condenser sensor has been installed an electronic fan speed control (set up at 16 bar by its adjusting screw) and a manual reset type hi pressure control.

The fan speed control supplies a variable power to the fan motor so to modulate its speed and keep to a constant value the discharge pressure.

The hi pressure control is used only as a safety device to switch OFF the operation of the machine in case of fan motor failure.

	MC 16-46 MF 56	MV 450-600-1000 OLD STYLE	MFE 61	MF 83
Remote air cooled condenser & fan motor assy	620418 00	620418 00	620418 01	620418 02
Fan motor assy - LU.VE.-CONTARDO	001028 30	001028 30	001028 30	*****
Fan motor assy - ECO	001028 32	*****	001028 32	001028 32
Hi pressure control (safety)	620498 00	620231 01	620498 00	620498 00
Fan speed control/Electronic device	620500 00	*****	620500 00	620500 00
Fan pressure control	*****	CM 19550624	*****	*****
Low pressure control	*****	*****	*****	620451 00
Liquid receiver	*****	CM 19635339	*****	*****
AEROQUIP male connection - LIQUID	650438 01	650438 01	650438 00	650438 00
AEROQUIP female connection - LIQUID	650437 01	650437 01	650437 00	650437 00
AEROQUIP male connection - GAS	650438 01	650438 01	650438 00	650438 05
AEROQUIP female connection - GAS	650437 01	650437 01	650437 00	650437 05

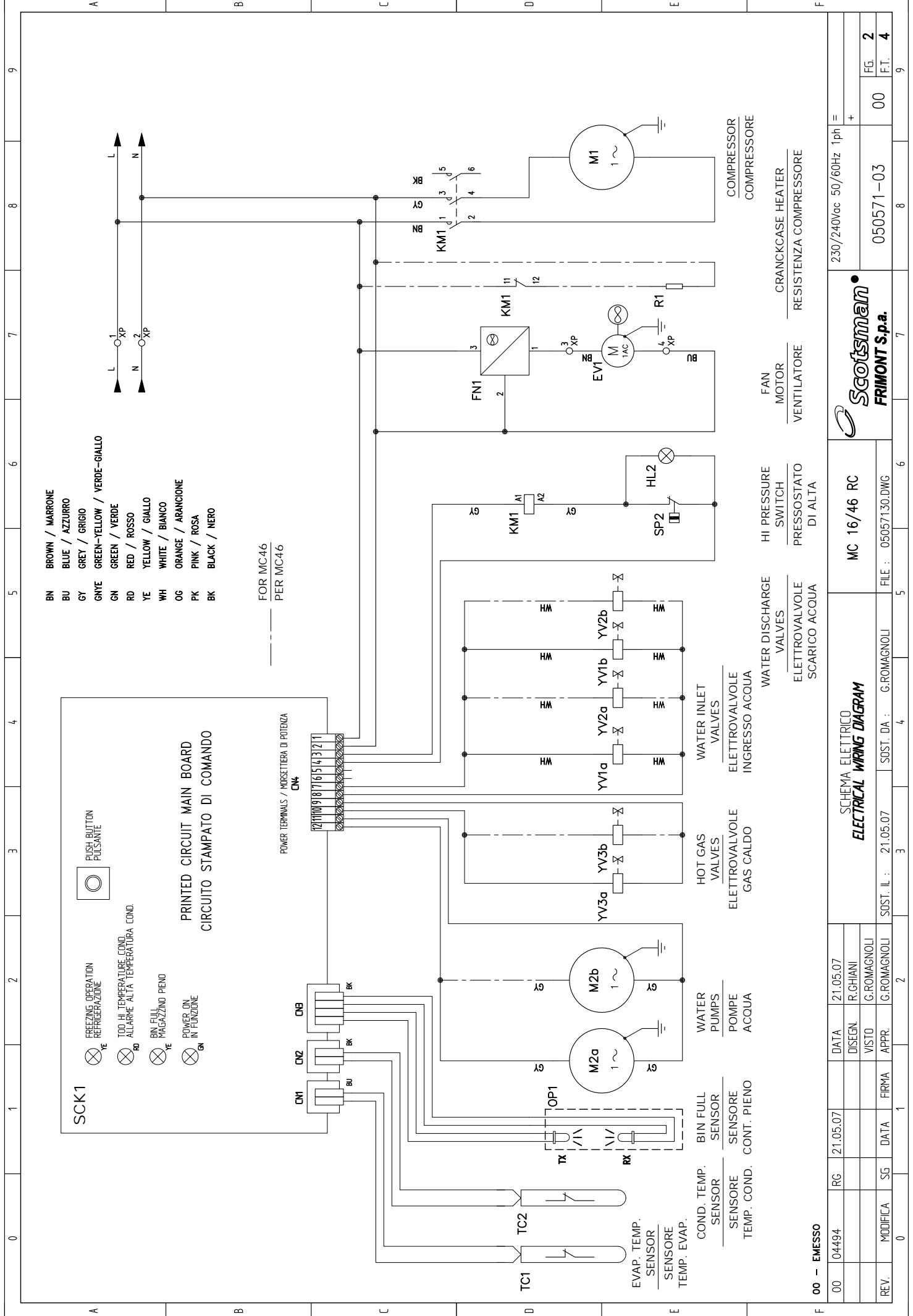

**00 - EMESSO**

00	04494	RG	21.05.07	DATA	21.05.07
				DESIGN.	R.GHIANI
				VISTO	G.ROMAGNOLI
				APPR.	G.ROMAGNOLI
REV.	MODIFICA	SG	DATA	FIRMA	
			21.05.07	SOST. IL :	3
				SOST. DA :	4
				FILE :	5
					6
					7
					8
					9



MC 16/46 RC

230/240Vac 50/60Hz 1ph =

050571-03

FG. 2

F.T. 4

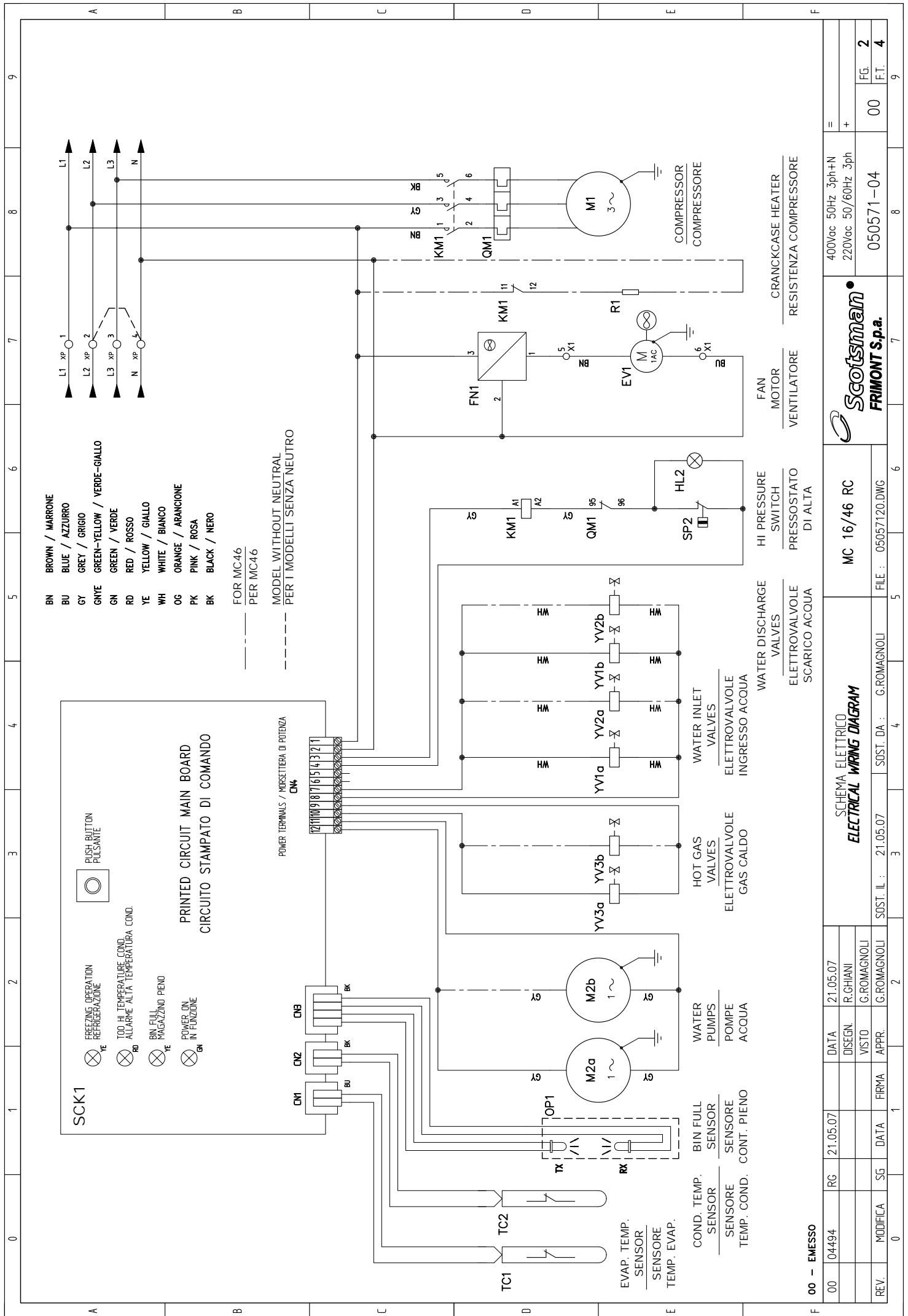

00 - EMESSO

REV.	MODIFICA	SG	DATA	FIRMA	APPR.	SOST. IL.	21.05.07	SOST. DA.	G.ROMAGNOLI	FILE	05057120.DWG
00	04494	RG	21.05.07	DATA	21.05.07						
				DESIGN.	R.GHIANI						
				VISTO	G.ROMAGNOLI						
				APPR.	G.ROMAGNOLI						

**SCHEMA ELETTRICO**  
**ELECTRICAL WIRING DIAGRAM**

MC 16/46 RC



400Vac 50Hz 3ph+N  
220Vac 50/60Hz 3ph

050571-04

FG. 2  
F.T. 4

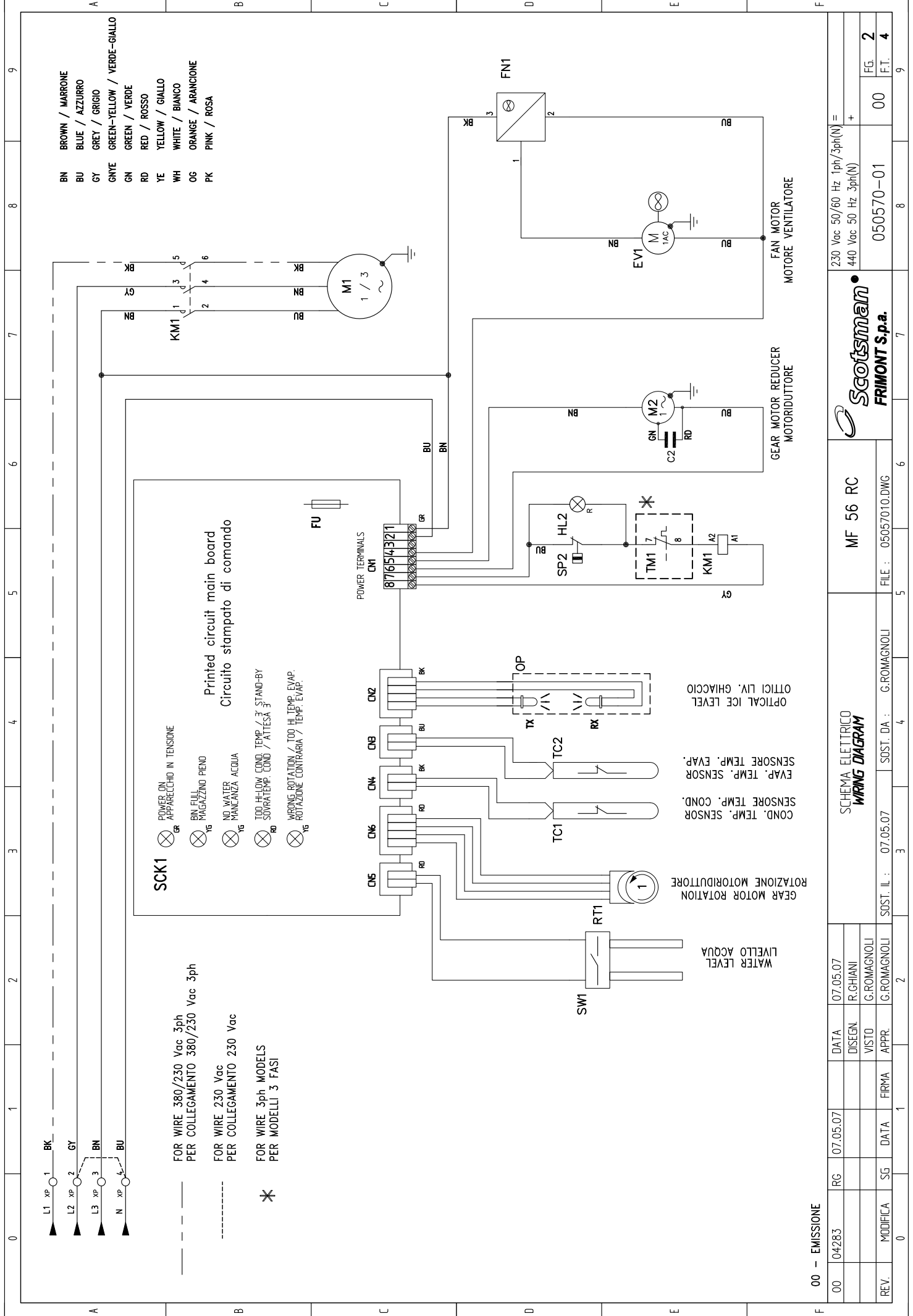

- BN BROWN / MARRONE
- BU BLUE / AZZURRO
- GY GREY / GRIGIO
- GN GREEN-YELLOW / VERDE-GIALLO
- GN GREEN / VERDE
- RD RED / ROSSO
- YE YELLOW / GIALLO
- WH WHITE / BIANCO
- OG ORANGE / ARANCIONE
- PK PINK / ROSA

**SCK1**

- POWER ON APPARECCHIO IN TENSIONE
- BN FULL MAGAZZINO PIENO
- NO WATER MANCANZA ACQUA
- TOO HI-LOW COND. TEMP. / 3' STAND-BY SOVRATEMP. COND. / ATTESA 3'
- WRONG ROTATION / TOO HI TEMP. EVAP. ROTAZIONE CONTRARIA / TEMP. EVAP.

**Printed circuit main board**  
Circuito stampato di comando

- FOR WIRE 380/230 Vac 3ph PER COLLEGAMENTO 380/230 Vac 3ph
- FOR WIRE 230 Vac PER COLLEGAMENTO 230 Vac
- FOR WIRE 3ph MODELS PER MODELLI 3 FASI

00 - EMISSIONE

00	04283	RG	07.05.07	DATA	07.05.07	R.GHIANI	DESIGN.	
		SG	07.05.07	DATA		G.ROMAGNOLI	VISTO	
REV.	MODIFICA			FIRMA		G.ROMAGNOLI	APPR.	
						SOST. IL. :	07.05.07	
						SOST. DA. :	G.ROMAGNOLI	
						FILE :	05057010.DWG	
						<b>MF 56 RC</b>		
						<b>Scotsman</b>		
						<b>FRIMONT S.p.a.</b>		
						230 Vac 50/60 Hz 1ph/3ph(N) =		
						440 Vac 50 Hz 3ph(N)		
						050570-01	00	FG. 2
								F.T. 4

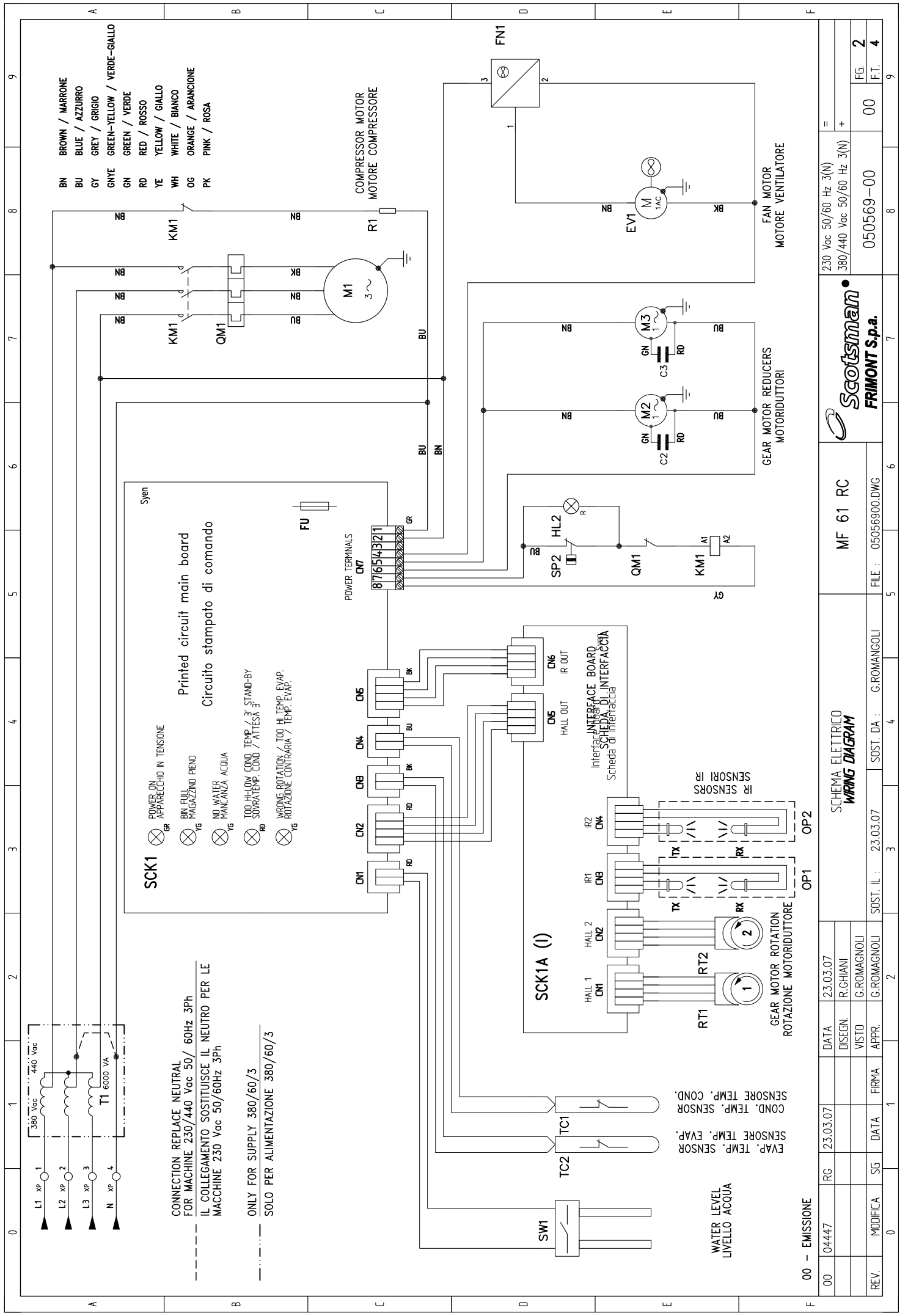

CONNECTION REPLACE NEUTRAL  
FOR MACHINE 230/440 Vac 50/ 60Hz 3Ph  
IL COLLEGAMENTO SOSTITUISCE IL NEUTRO PER LE  
MACCHINE 230 Vac 50/60Hz 3Ph

ONLY FOR SUPPLY 380/60/3  
SOLO PER ALIMENTAZIONE 380/60/3

- SCK1**
- ⊗ GR POWER ON / APPARECCHIO IN TENSIONE
  - ⊗ YG BN FULL MAGAZZINO PIENO
  - ⊗ YG NO WATER / MANCANZA ACQUA
  - ⊗ RD TOO HI/LOW COND. TEMP. / 3<sup>rd</sup> STAND-BY / SOVRATEMP. COND. / ATTESA 3
  - ⊗ YG WRONG ROTATION / TOO HI TEMP. EVAP. / ROTAZIONE CONTRARIA / TEMP. EVAP.

Printed circuit main board  
Circuito stampato di comando

00 - EMISSIONE

00	04447	RG	23.03.07					
REV.	MODIFICA	SG	DATA	FIRMA	APPR.			

			23.03.07					
			DATE	DESIGN.	VISTO			
				R.GHIANI	G.ROMAGNOLI			

SCHEMA ELETTRICO  
**WIRING DIAGRAM**

MF 61 RC  
FILE : 05056900.DWG  
SOST. DA : G.ROMAGNOLI



=	230 Vac 50/60 Hz 3(N)	
+	380/440 Vac 50/60 Hz 3(N)	
	050569-00	00
		FG. 2
		F.T. 4



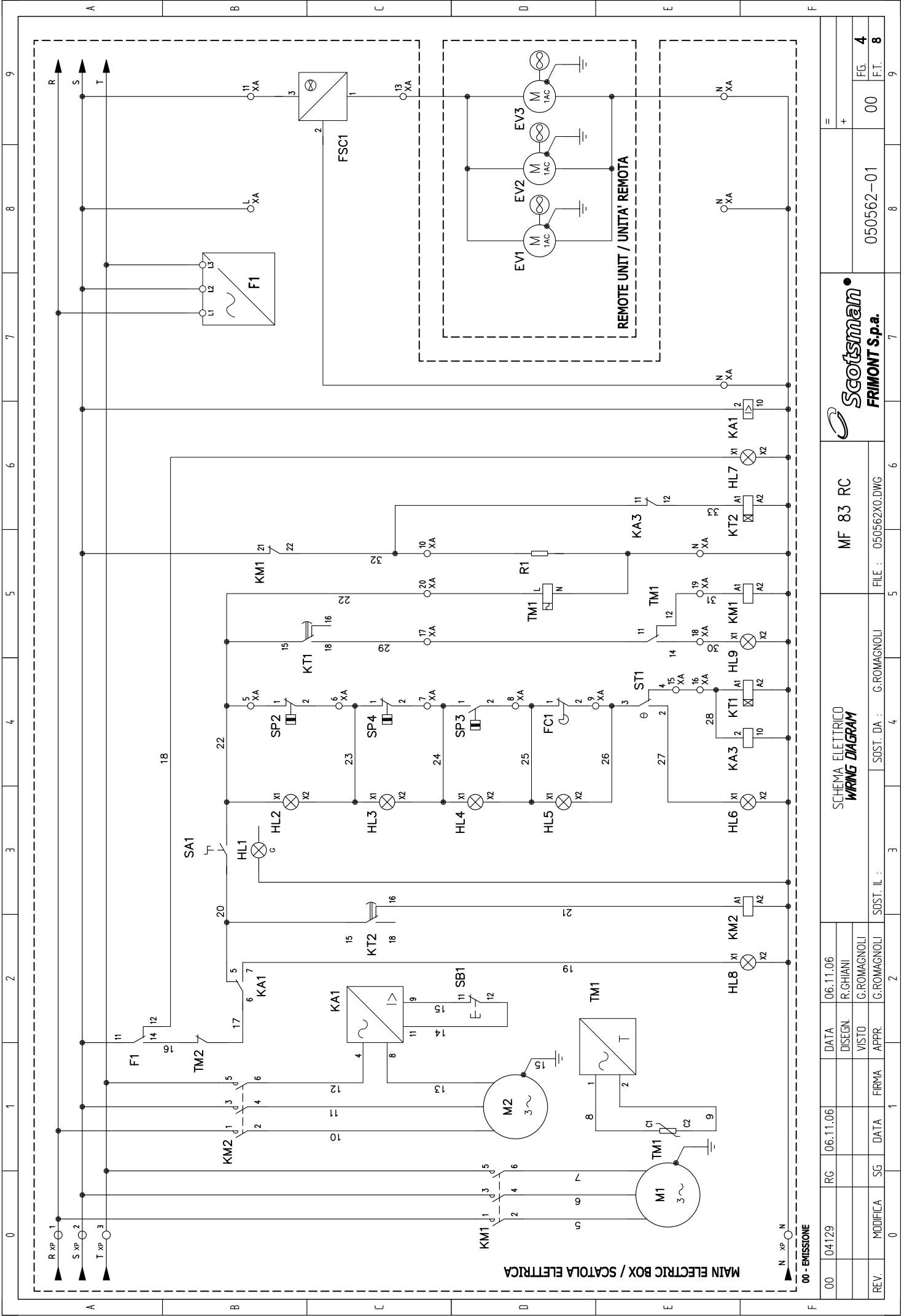











































MAIN ELECTRIC BOX / SCATOLA ELETTRICA

00 - EMISSIONE

REV.	MODIFICA	SG	DATA	FIRMA	SOST. IL.	3	4	5	6	7	8	9
00	04129	RG	06.11.06									
			DATA	06.11.06								
			DISIGN.	R.GHIANI								
			VISTO	G.ROMAGNOLI								
			APPR.	G.ROMAGNOLI								
					SOST. DA :	G.ROMAGNOLI	FILE :	050562X0.DWG				
										MF 83 RC		
										<b>FRIMONT S.p.a.</b>		
										050562-01		
										FG.	00	4
										FT.		8

0	1	2	3	4	5	6	7	8	9		
A	B	C	D	E	F						
Sim.\Sym.	Sigla \Item	Funzione \Use Type	Sim.\Sym.	Sigla \Item	Funzione \Use Type	Sim.\Sym.	Sigla \Item	Funzione \Use Type	Sim.\Sym.	Sigla \Item	Funzione \Use Type
	EV1	FAN motor Ventilatore		HL6	Bin full Magazzino pieno		M2	Drive motor Motoriduttore			
	EV2	FAN motor Ventilatore		HL7	Wrong phase alarm Allarme sequenza fasi		R1	Crankcase heater Resistenza compressore			
	EV3	FAN motor Ventilatore		HL8	Current drive-motor alarm Allarme amperometrica motoriduttore		SA1	Switch Interruttore			
	F1	3-phase monitoring relay controllo sequenza fasi		HL9	Compressor thermal protector alarm Allarme protezione termica compressore		SB1	Reset push button Pulsante reset			
	FC1	Spout switch Interruttore bocchetta		KA1	Current drive-motor relay Relè amperometrico motoriduttore		SP2	HI pressure control safety Pressostato sicurezza alta pressione			
	FSC1	Fan Speed Fan Speed		KA3	Drive-motor start relay Relè anticipata motoriduttore		SP3	Water pressure control Controllo bassa pressione acqua			
	HL1	Power ON Macchina in funzione		KM1	Compressor contactor Teleruttore compressore		SP4	LOW pressure control Pressostato basa pressione			
	HL2	HI pressure alarm Allarme alta pressione		KM2	Drive-motor contactor Teleruttore motoriduttore		ST1	Thermostat Termostato			
	HL3	LOW pressure alarm Allarme bassa pressione		KT1	Compressor timer delay Ritardatore compressore		TM1	Compressor thermal relay Relè protezione termica compressore			
	HL4	Water alarm Allarme mancanza acqua		KT2	Drive-motor timer delay Ritardatore motoriduttore		TM1	Compressor thermal protector Protettore termico compressore			
	HL5	Spout switch light Spia interruttore bocchetta		M1	Compressor Compressore						

00 - EMISSIONE

00	04129	RG	06.11.06	DATA	06.11.06
			DISEGN.		R.GHIANI
			VISTO		G.ROMAGNOLI
			APPR.		G.ROMAGNOLI
REV.	MODIFICA	SG	DATA	FIRMA	

LEGENDA FUNZIONI  
FUNCTIONS  
LEGEND

SOST. IL :

SOST. DA :

G.ROMAGNOLI

FILE :

050562X0.DWG

MF 83 RC



050562-01

00

FG. 5  
F.T. 8

A TERMINI DI LEGGE LA "CASTELMAC" SI RISERVA LA PROPRIETA' ESCLUSIVA DEL PRESENTE DISEGNO CHE NON DEVE ESSERE RIPRODOTTO O TRASMESSO A TERZI SENZA AUTORIZZAZIONE

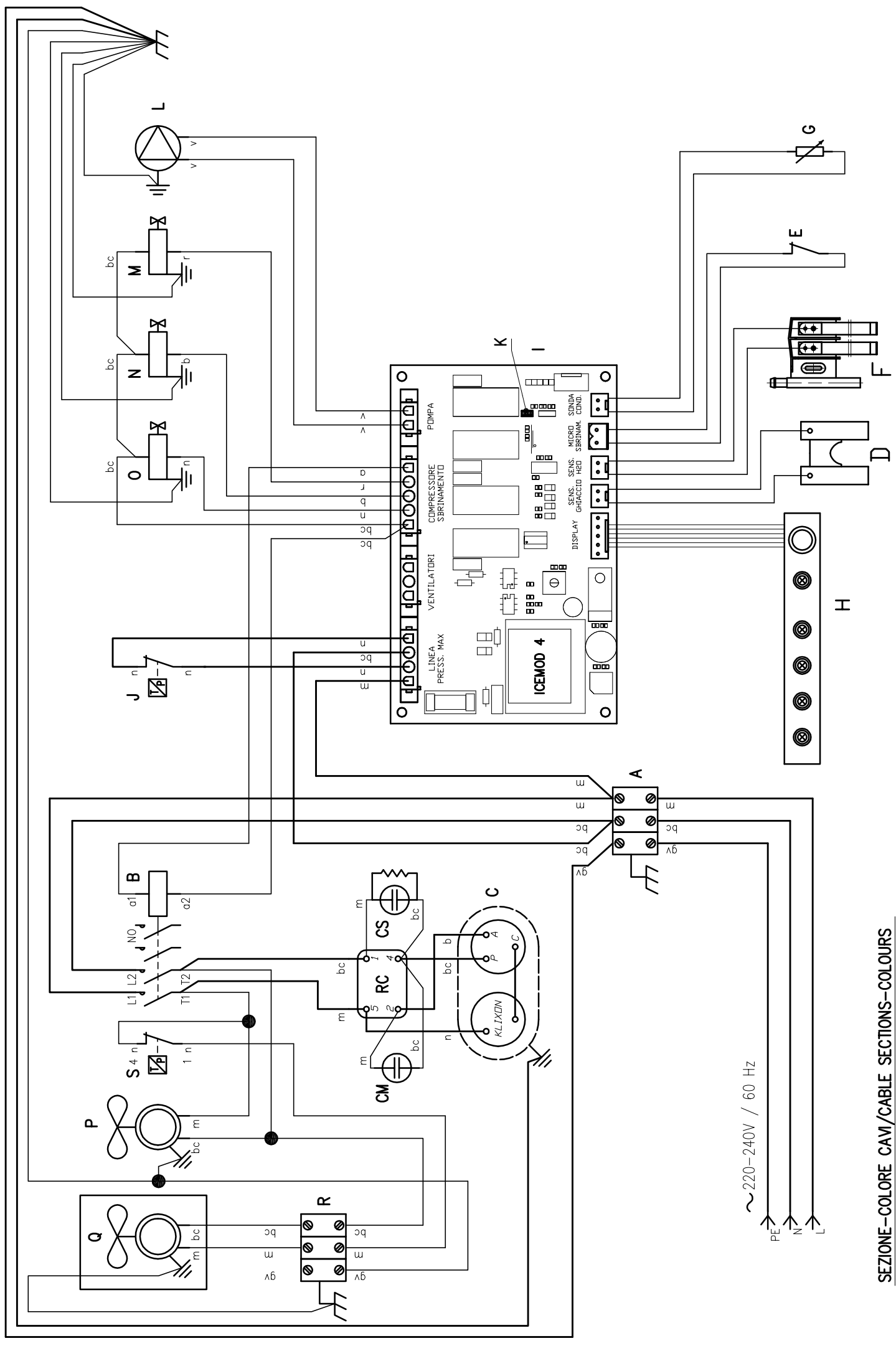

SEZIONE-COLORE CAV/CABLE SECTIONS-COLOURS

\_\_\_\_\_ 1 mmq \_\_\_\_\_ 1.5 mmq

m	marrone	brown
bc	blu chiaro	light blue
gv	giallo/verde	yellow/green
b	bianco	white
n	nero	black
r	rosso	red
a	arancio	orange
v	viola	purple

NOTA X PRODUZIONE:

PONTICELLO K= APERTO (Reset Automatico)

A	MORSETTIERA INGRESSO INPUT TERMINAL BOARD
B	TELERUTTORE COMPRESSORE COMPRESSOR CONTACTOR
C	COMPRESSORE COMPRESSOR
D	SENSORE GHIACCIO ICE SENSOR
E	MICRO FINE SBRINAMENTO END DEFROSTING SWITCH
F	SENSORE LIVELLO ACQUA WATER LEVEL SENSOR
G	SONDA TEMPERATURA CONDENSATORE CONDENSER TEMPERATURE PROBE
H	SCHEDA LED LED CARD
I	SCHEDA ELETTRONICA ELECTRONIC CARD
J	PRESSOSTATO DI MASSIMA MAX PRESSURE SWITCH
K	PONTICELLO RESET AUTOMATICO AUTOMATIC RESET SWITCH
L	ELETTROPOMPA WATER PUMP
M	ELETTROVALVOLA CARICO ACQUA WATER INLET VALVE
N	ELETTROVALVOLA SCARICO ACQUA WATER DISCHARGE VALVE
O	ELETTROVALVOLA GAS CALDO HOT GAS VALVE
P	VENTILATORE COMPRESSORE COMPRESSOR FAN MOTOR
Q	VENTILATORE CONDENSATORE RMOTO REMOTE CONDENSER FAN MOTOR
R	MORSETTIERA VENTILATORE REMOTO TERMINAL BOARD REMOTE FAN MOTOR
S	PRESSOSTATO VENTILATORE FAN PRESSURE SWITCH
RC	RELE' COMPRESSORE COMPRESSOR RELAY
CS	CONDENSATORE SPUNTO START CONDENSER
CM	CONDENSATORE MARCIA RUN CONDENSER

IND.	DATA	MODIFICHE	DIS.	VERIF.	COMUNIC.
QUOTE SENZA INDICAZIONE DI TOLLERANZA + FORI TOLLERANZA -		GRADO DI PRECISIONE MEDIO UNI ISO 2768 m	3470CT		
MATERIALE		GRADO DI LAVORAZ.			
N. PEZZI	1	TRATT. SUPERFICIALE		TRATT. TERMICI	
DATA	06-11-02	MDD. 450-600 SPLIT			
DIS.	STOCCO	SCHEMA ELETTRICO			
VERIF.	PORTELLI	CASTELMAC			
ASS.		CastelFranco V.to			
SCALA 1:1		CODICE N°			
1 2 3 4 5 6 7 8 9		71510259/0			