

144/430(440)MHz FM DUAL BANDER

TH-79 A/E

SERVICE MANUAL

KENWOOD

© 1994-6 PRINTED IN JAPAN
B51-8273-00(B)1401

CONTENTS

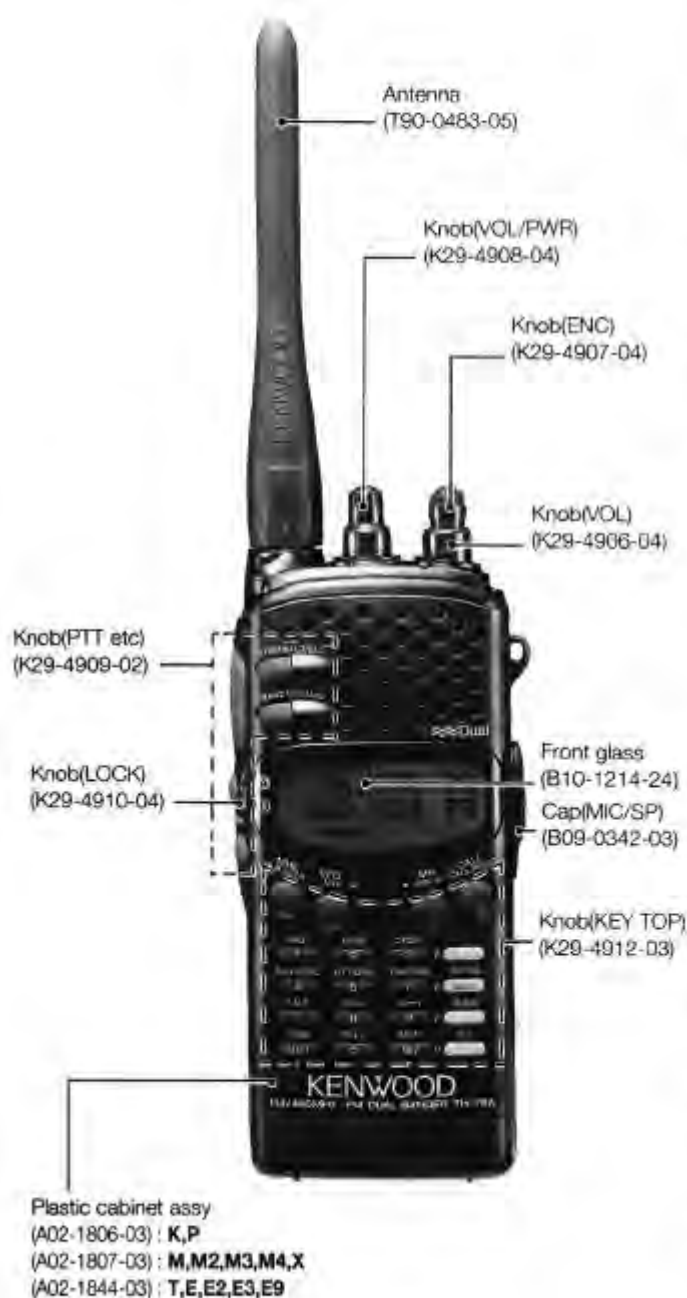

DISASSEMBLY FOR REPAIR	2
CIRCUIT DESCRIPTION	4
DESCRIPTION OF COMPONENTS	15
SEMICONDUCTOR DATA	18
PARTS LIST	22
EXPLODED VIEW	43
PACKING	45
ADJUSTMENT	47
TERMINAL FUNCTION	53
WIRING DIAGRAM	55
PC BOARD VIEWS	
TX-RX UNIT(X57-440X-XX)(C/7)	57
TX-RX UNIT(X57-440X-XX)(D/7)	57
TX-RX UNIT(X57-440X-XX)(E/7)	59
TX-RX UNIT(X57-440X-XX)(F/7)	60
TX-RX UNIT(X57-440X-XX)(G/7)	61
TX-RX UNIT(X57-440X-XX)(A/7)	63
TX-RX UNIT(X57-440X-XX)(B/7)	67
SCHEMATIC DIAGRAM	71
BLOCK DIAGRAM	81
CTCSS UNIT(X52-3290-00) : TSU-8	83
SC-41/42/43(SOFT CASE)	83
BT-9(BATTERY CASE)	83
SPECIFICATIONS	BACK COVER

Photo is TH-79A.

TH-79 A/E

DISASSEMBLY FOR REPAIR

How to remove the printed circuit board

1. Open the case

- After removing the case fastener screw, open the upper and lower halves of the case.
- When you pull out flat cable (1) and pin connector (2), the main unit separates into two parts, A and B.

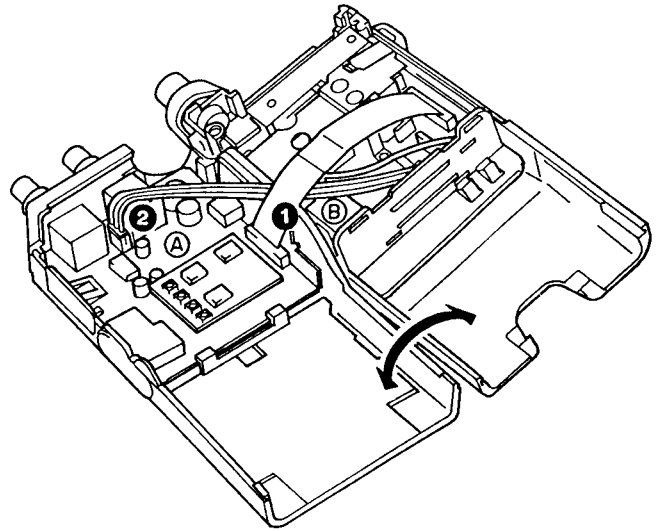

2. Remove the holder

- Place the edge of a flat screwdriver against the holder and remove it by prying upward. (3)

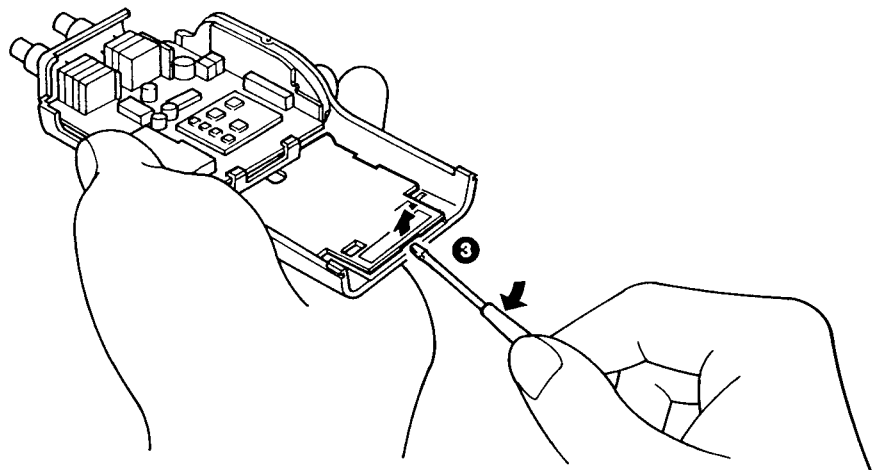

3. How to remove the A unit

- After pulling out the dial, remove panel (4). (Don't break the tabs at both ends.)
- Remove the cap (5) and LOCK key (6).
- From the arrow sections (7), "float" the unit and separate it from the case.

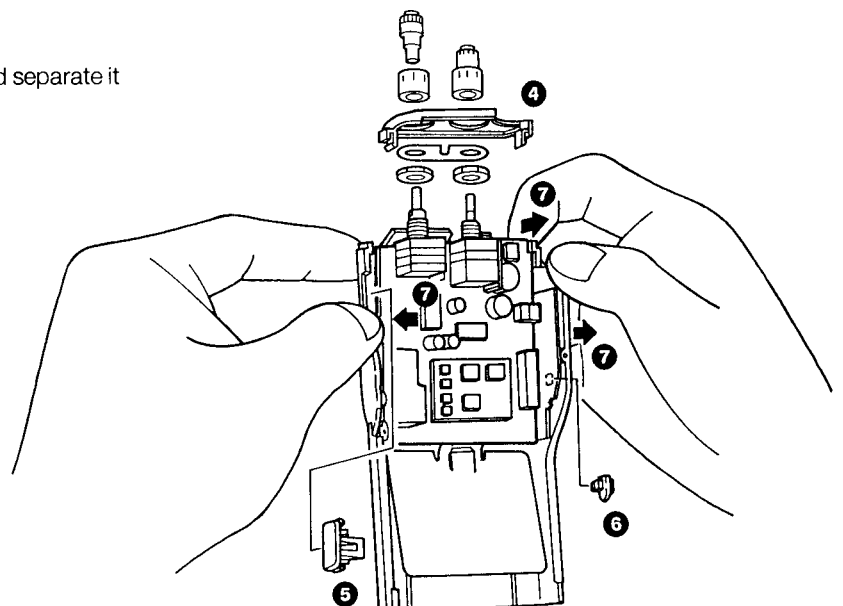

DISASSEMBLY FOR REPAIR

4. How to remove the shield cover and the B unit

- Remove the rubber ring (8) and the panel (9).
- Cut the cushion (waterproof sheet) with a cutter(10).
- The shield cover (11) comes apart when the five screws and the three solderings (see arrows) are removed.
- Remove the one soldering holding the ANT terminal (12).
- The B unit separates from the lower case when the two screws fastening the BNC receptacle are removed.
- Pull out the holder (13) and the BATT terminal (14) while being careful not to bend them.

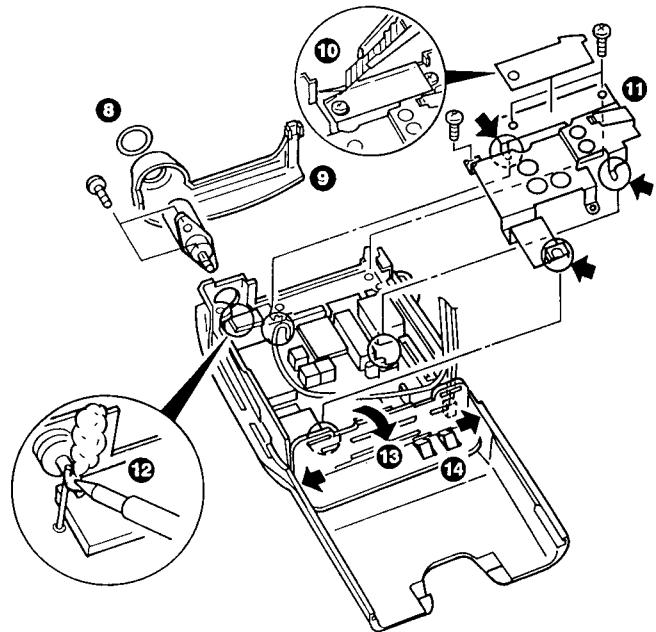

5. How to remove the LCD ASSY

- After separating the A unit from the upper case, remove the unit's two solderings (15).
- The LCD ASSY (17) separates from the A unit when the four claws (16) fastening it are removed.

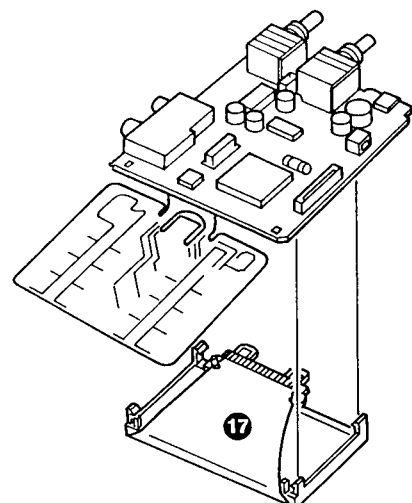
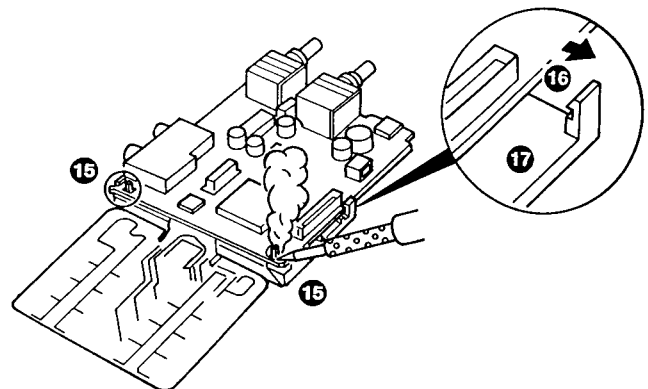

TH-79 A/E

CIRCUIT DESCRIPTION

(1) Frequency configuration

- The TH-79 A/E has independent PLL circuits for the VHF and UHF bands, It also has two IF channels, so both bands can receive at the same time.
- Each band has a sub-reception circuit (Sub-VHF, Sub-UHF), so both VHF and UHF waves can be received (V x V, U x U) simultaneously.
- The Sub-VHF 1st-LOCAL is made from the halving of UHF-VCO.
The Sub-UHF 1st-LOCAL is made by doubling the VHF-VCO.

The VHF 2nd-LOCAL is made by tripling the REF-OSC (12.8MHz).

- The frequency configuration is as shown in Fig. 1 and Table 1.

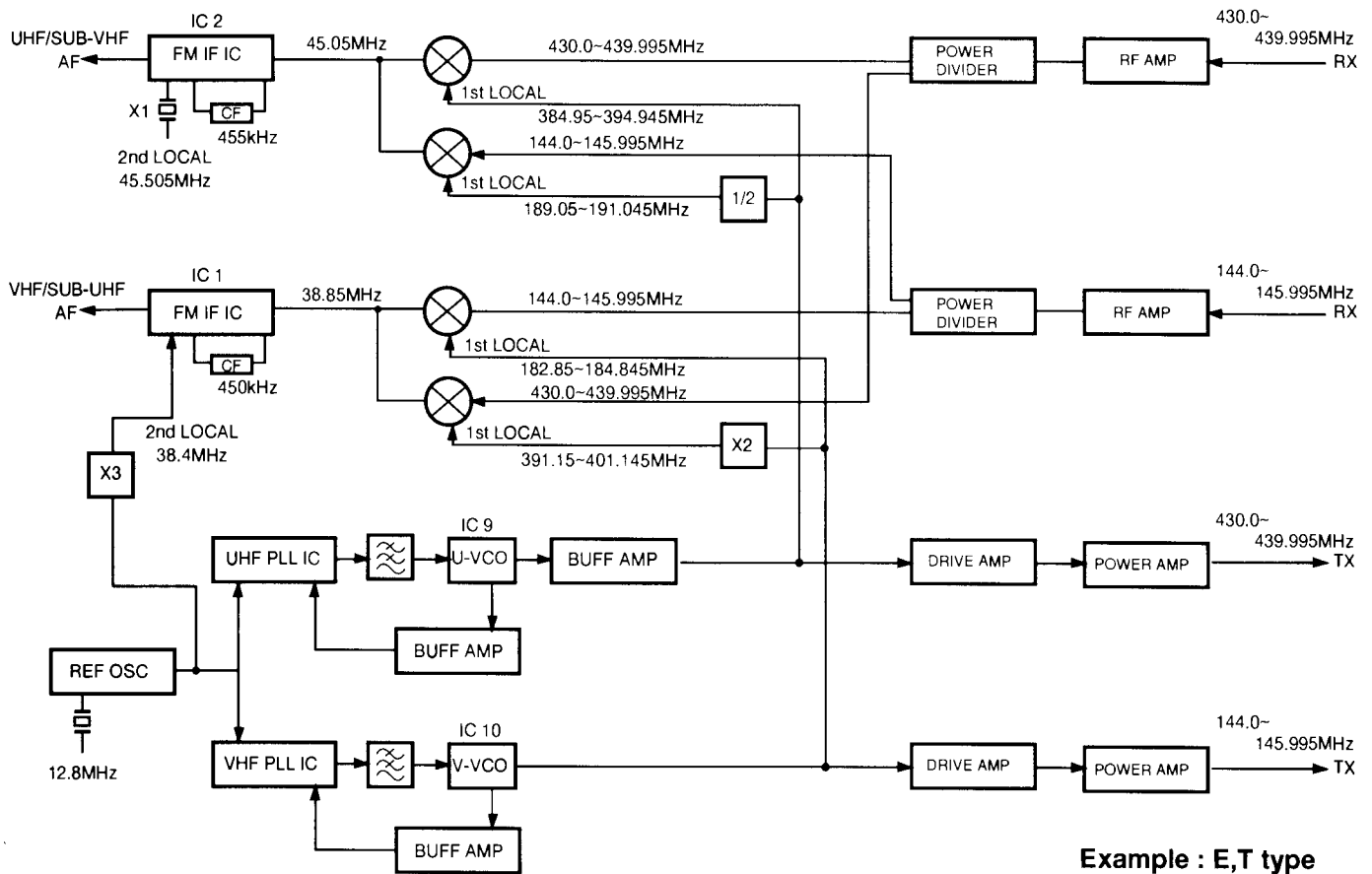

Example : E,T type

Fig.1 Frequency configuration

Receiving method	Double super heterodyne method	UHF	S-VHF	VHF	S-UHF
	1st LOCAL 45.05MHz	Lower	Upper	/	/
	2nd LOCAL 455kHz	Upper	Upper	/	/
	1st LOCAL 38.85MHz	/	/	Upper	Lower
	2nd LOCAL 450kHz	/	/	Lower	Lower
Transmission method	Direct oscillation amplification method				
Modulation method	Variable reactance phase modulation				

Table 1

CIRCUIT DESCRIPTION

(2) Receiver signal channel

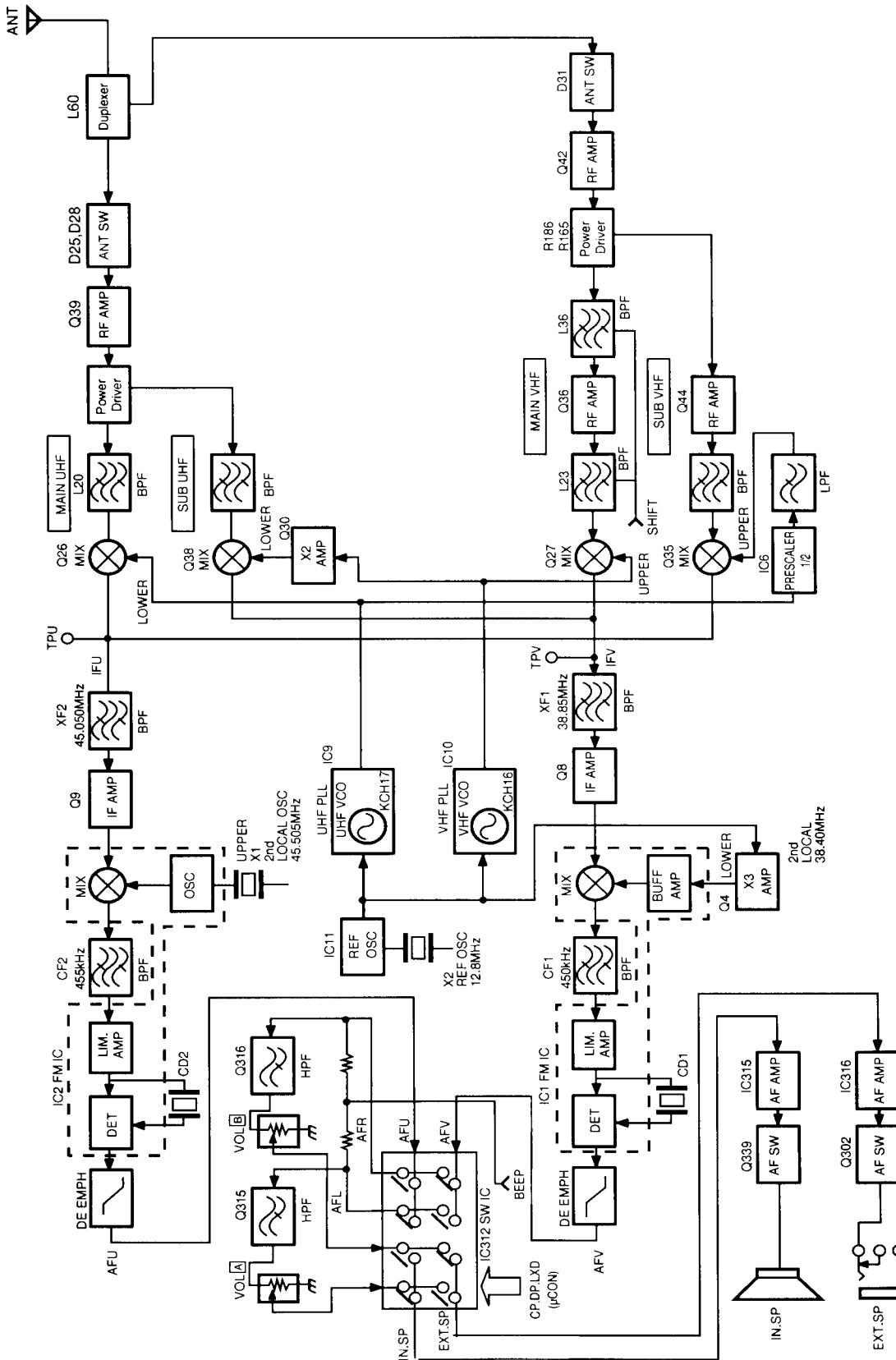

Fig. 2 Receiver section configuration

CIRCUIT DESCRIPTION

[UHF reception]

The 1st-LOCAL signal (lower hetero) made from the direct oscillation of the U-VCO's IC9 (KCH-17) is mixed with the desired signal to become the IFU's 45.05MHz. It is further mixed with the 2nd-LOCAL signal (upper hetero) from the X1's quartz crystal oscillation circuit to become 455kHz, is quadrature detected at IC2 and becomes an audio signal.

[VHF reception]

The 1st-LOCAL signal (upper hetero) made from the direct oscillation of the V-VCO's IC10 (KCH-16) is mixed with the desired signal to become the IFV's 38.85MHz. It is further mixed with the 2nd-LOCAL signal (lower hetero) to become 450kHz, is quadrature detected at IC1 and becomes an audio signal.

[Sub-VHF reception]

The Sub-VHF is mixed with the 1st-LOCAL (upper hetero), made by the halving of U-VCO, to become IFU 45.05 MHz.

[Sub-UHF reception]

The Sub-UHF is mixed with the 1st-LOCAL (lower hetero), made by the doubling of V-VCO, to become IFV 38.85 MHz.

[Audio circuitry]

- Audio signals AFU and AFV detected at IC1 and IC2 enter cross-point switch IC312 and are switched to either AFL or AFR. AFL and AFR pass through VOL[A] and VOL[B], re-enter IC312 and are switched to either IN.SP or EXT.SP. These signals are amplified by independent audio amplifiers IC315 and IC316 and are output either by the internal or the external speaker.
- IC312's control signal, beep sound, and DTMF signal are output from microprocessor IC304.

Item	Specification
Nominal center frequency (fo)	38.850MHz
Pass bandwidth	±7.5kHz or more at 3dB
Attenuation bandwidth	±28kHz or more at 40dB
Guaranteed attenuation	70dB or more within ±1,000kHz
Ripple	1.0dB or less
Insertion loss	2.0dB or less
Terminal impedance	520Ω/2pF

Table 2 MCF (L71-0439-05) characteristics (TX-RX unit XF1)

Item	Specification
Center frequency (fo)	450kHz within ±1.5kHz
6dB bandwidth	±7.5kHz or more
40dB bandwidth	±15kHz or less
Ripple	20dB or less (450 within ±1.5kHz)
Guaranteed attenuation (±100kHz)	27 dB or more
Insertion loss	6dB or less
I/O impedance	1.5kΩ

Table 3 Ceramic filter (L72-0902-05) characteristics (TX-RX unit CF1)

Item	Specification
Nominal center frequency (fo)	45.050MHz
Pass bandwidth	±7.5kHz or more at 3dB
Attenuation bandwidth	±22kHz or more at 25dB
Guaranteed attenuation	80dB or more within ±910kHz Spurious : 40dB or more
Ripple	1.0dB or less
Insertion loss	4dB or less
Terminal impedance	800Ω/2pF

Table 4 MCF (L71-0409-15) characteristics (TX-RX unit XF2)

Item	Specification
Nominal center frequency of 65dB bandwidth(fo)	455kHz ±1.5kHz or less
6dB bandwidth	±7.5kHz or more
40dB bandwidth	±15kHz or more
Pass bandwidth ripple	1.5dB or less(455± within 1.5kHz)
Guaranteed attenuation (±100kHz)	27dB or more
Insertion loss	6dB or less
I/O impedance	1.5kΩ

Table 5 Ceramic filter(L72-0362-05) characteristics (TX-RX unit CF2)

CIRCUIT DESCRIPTION

(3) Transmission signal channel

The transmission system diagram is as shown in Fig. 3.

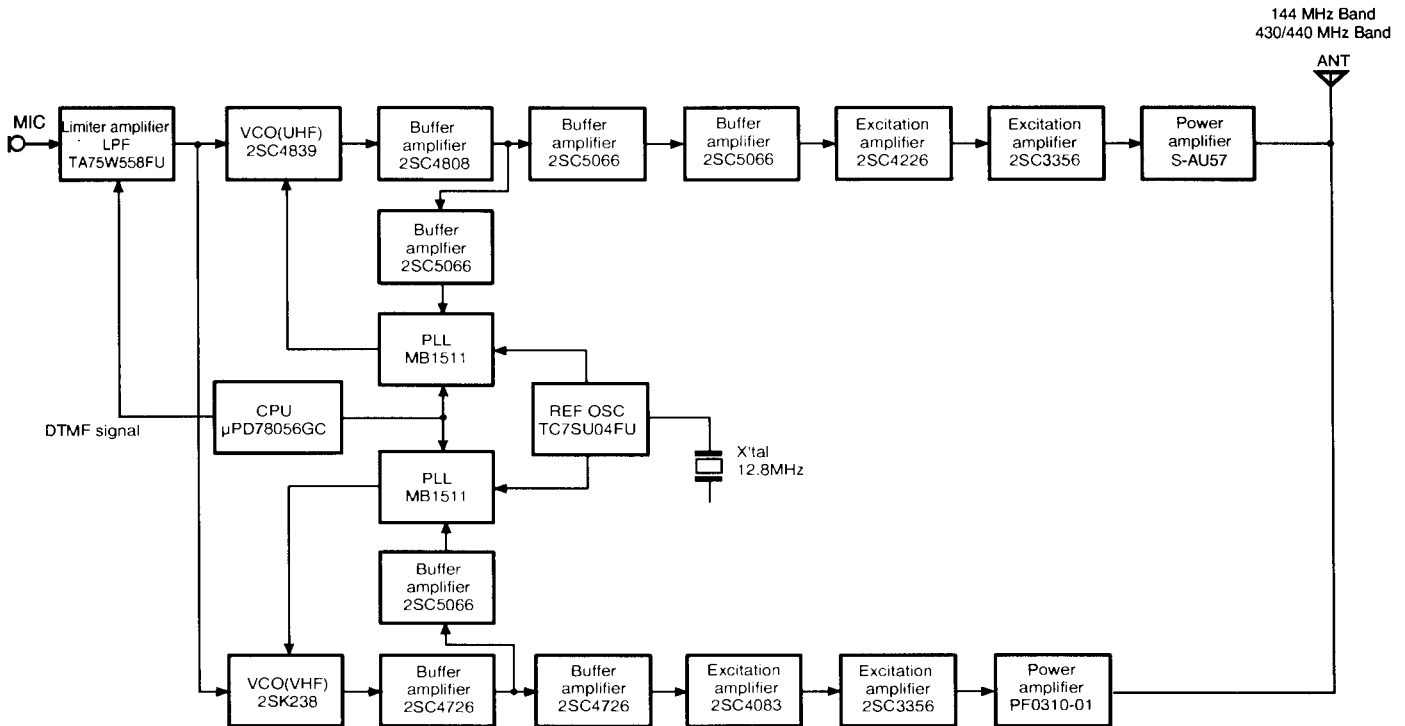

Fig.3 Transmission system diagram

3-1 Modulation circuit

The audio signal from the microphone is subjected to pre-emphasis, limiter amplification, and splatter filtering by the IC308 (TA75W558FU). VHF/UHF switching is done by Q337, and frequency deviation is adjusted by VR301 and V302.

The modulation signal is applied to the modulation varicaps of the VCOs for both VHF and UHF, and undergoes reactance modulation. When DTMF is used, the input terminals are shorted at Q301.

3-2 Driver, final amplifier

VHF band VCO output is amplified by a two-stage and UHF band VCO output by a three-stage amplifier, after which they are each input to their respective power modules. After passing through each band's antenna switches, the output passes through the chip duplexer (L60) and is supplied to the antenna.

3-3 APC circuit

The APC circuit is for stabilizing transmission output. It detects the power module's drain current and regulates the transmission output. We shall explain using the UHF band as an example. (Fig. 4)

To differential DC amplifier IC317 is applied the reference

voltage obtained by potential division of voltage-regulated zener diode D316 through transmission output adjustment VR307 (EL power), R420, VR305 (Hi power) and R421, as well as the detection voltage generated by R434, R435 and R436 in proportion to the power module's drain current. The output of IC317 (No. 6pin) outputs voltage in proportion to the difference between the reference voltage and the detection voltage, which is inverted at Q335, giving the APC voltage. This APC voltage regulates the power module's power regulation terminal, maintaining a constant transmission output. Also, when the transmission is turned off, Q324 turns off and Q305 turns on, rapidly discharging the APC voltage, for stable turning off of the power module. Transmission output switching is regulated by Q320 shift register, varying the reference voltage to fix the transmission output at approximately 4.7W (Hi), approximately 0.5W (Low) and approximately 30mW (EL).

3-4 Temperature protection circuit

To prevent thermal destruction of the power module, if the thermistor detects a temperature level of approximately 100° C, Q32 is turned on and the APC voltage is lowered to the level of the D20 zener diode voltage.

CIRCUIT DESCRIPTION

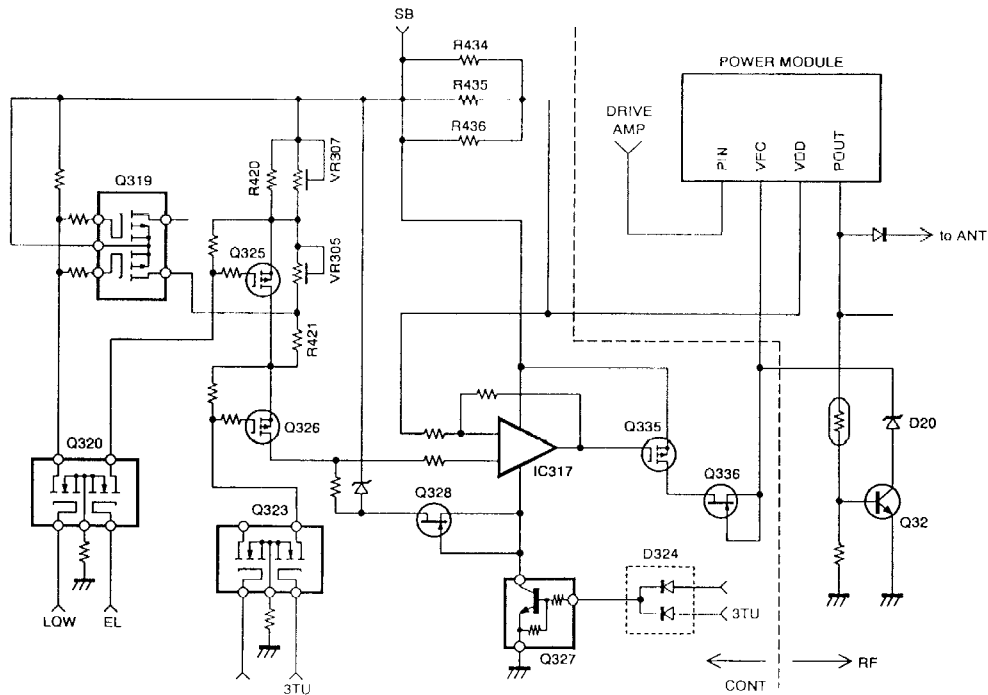

Fig. 4 APC / Temperature protection circuit (in the case of UHF)

(4) PLL circuit

The VHF and UHF bands each have independent PLLs and VCOs. The Ref OSC makes an independent oscillation circuit, applied oscillator signal to the V/U PLL IC and the tripling bipolar transistor.

● Reference oscillation circuit

X2: the 12.8MHz quartz crystal oscillates at IC11, the output of which is distributed and applied to IC4 and IC5. The reference oscillation frequency is divided at IC4 (VHF) and IC5 (UHF) to obtain 5kHz and 6.25kHz reference frequencies.

● Phase comparison

After amplifying the VCO output at Q22 (VHF) and Q21 (UHF), the comparison frequency is distributed at pulse swallow type PLL ICs IC4 and IC5.

Through phase comparison with the reference frequency obtained by dividing X2, a PLL synthesizer of 5kHz, 10kHz, 12.5kHz, 15kHz, 20kHz and 25kHz steps is configured.

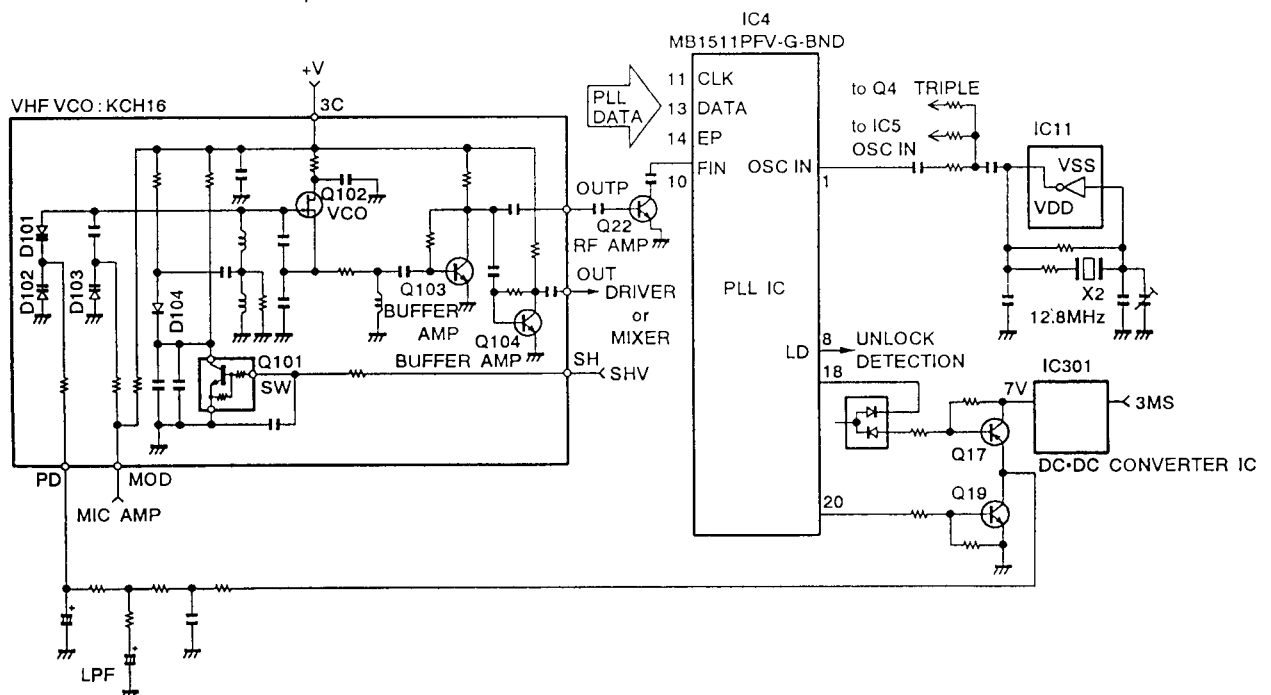

Fig. 5 PLL, VHF VCO circuit

CIRCUIT DESCRIPTION

● Lock voltage(VCO regulation voltage)

Due to the phase difference between the reference voltage and the comparison voltage, the pulse output from the 18th and 20th pins of IC4 is passed through the charge pump (Q17, Q19), has ripples removed at the LPF and becomes the lock voltage.

The charge pump power supply is stepped up from 3M at the DC-DC converter, raising to approximately 7V.

● VHF VCO (KCH16)

VHF VCO (KCH16), FET: directly oscillates the target frequency at the Colpitts oscillator circuit of Q102. The VCO regulation voltage is applied to varicap D101 and D102, changing the oscillation frequency. Also, during reception the T/R terminal becomes "H," turning on Q101 and D104 and switching the oscillation frequency.

During transmission, the audio signal is applied to varicap D103 to modulate the oscillation frequency.

● UHF VCO (KCH17)

UHF VCO (KCH17), bipolar transistor: directly oscillates the target frequency at the Colpitts oscillator circuit of Q2. The VCO regulation voltage is applied to varicap D1 and D2, changing the oscillation frequency. Also, during reception the T/R terminal becomes "L," turning off Q1 and D4 and switching the oscillation frequency.

During transmission, the audio signal is applied to varicap D4 to modulate the oscillation frequency.

● Unlock detection circuit

When the PLL is unlocked, the pulse output to IC4's LD terminal (pin No. 8) is waveform shaped at D7, R66 and C71, turning UL terminal A to the "L" level. the UL terminal voltage is detected at the microprocessor, regulating the timing off transmission/reception switching.

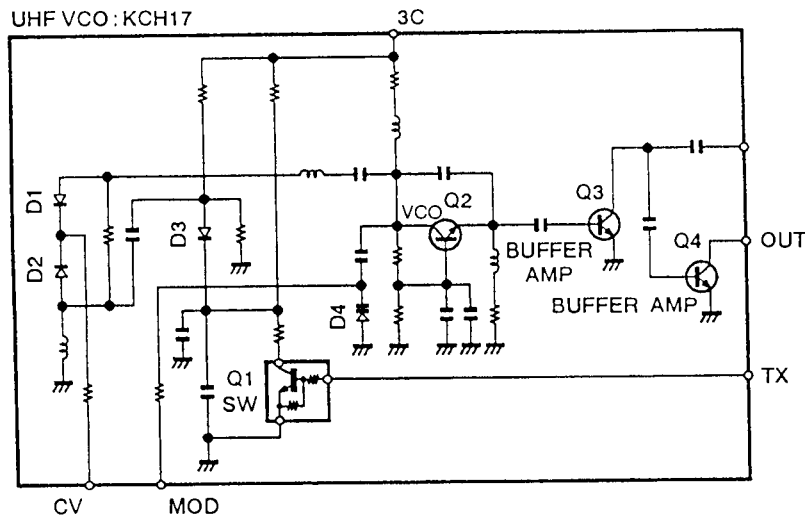

Fig. 6 UHF VCO circuit

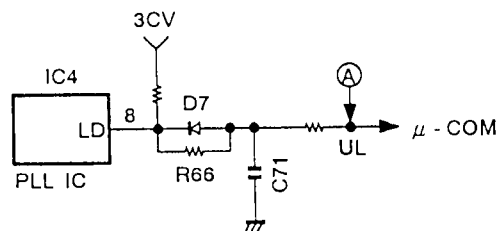

Fig. 7 Unlock detection circuit

TH-79 A/E

CIRCUIT DESCRIPTION

(5) Power supply circuit

5-1 Ni-Cd recharge circuit

A constant current of approximately 70mA is supplied to the Ni-Cd battery from the external power supply connected to the DC IN terminal, via the constant current circuit comprised by Q1 and D1.

If an external power supply is not connected to the DC IN terminal, the constant current circuit does not operate.

5-2 Power supply switching circuit

The power supply circuit is configured as shown in Fig. 8. Its branches are as follows.

RB	Power module power supply
3C	PLL (3CV, 3CU), reception circuit (3RV, 3RU, 3RSU, 3RSV, 3R36, 3R80, 3R43, 3R14) power supply
3T	AF AVR reference voltage, microphone amplifier bias
SB	Transmission circuit (drive, ANT switch) power supply, microphone amplifier power supply
3M	Microprocessor power supply, E ² PROM power supply, LCD power supply, reset circuit power supply, shift register power supply,
3MS	3C, 3T AVR reference voltage, cross-point switch IC power supply, voltage detector voltage
7C	PLL charge pump power supply
4M	Band shift circuit voltage
	TX, BUSY-LED illumination circuit power supply

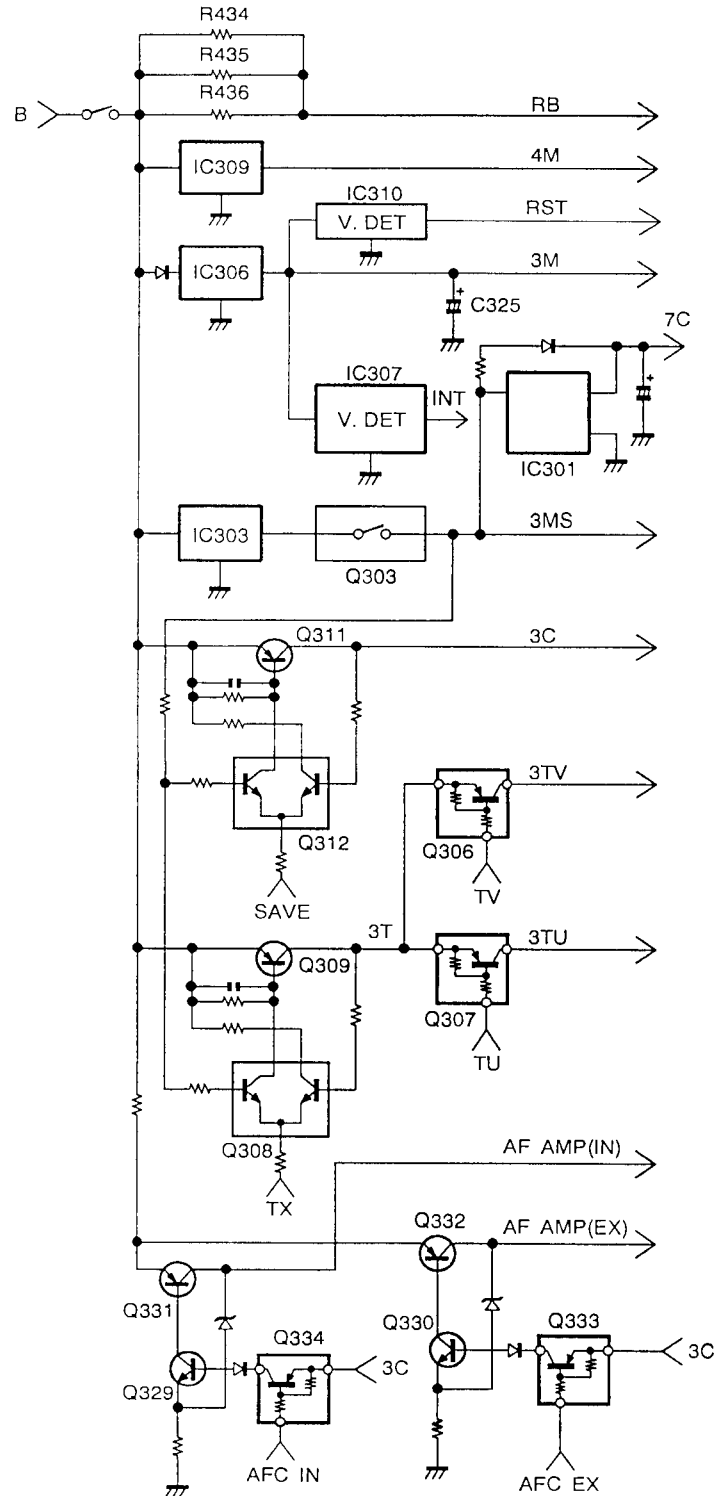

Fig. 8 Power supply circuit

CIRCUIT DESCRIPTION

(6) Microprocessor and peripheral circuits

6-1 Reset backup circuit

When SB is turned on, microprocessor IC304's V_{DD} and INT become +3.5V "H" as C235 charges. At this time, simultaneously with the microprocessor's actuation, RST become active, after which R340, C333 are cleared a few minutes later.

When SB is set OFF, voltage detect IC307 detects the 3M line voltage drop(3.0V) and sets the INT port to "L" when this happens the microprocessor enters backup mode, sends data to IC302 (E²PROM). While C325 is discharging, the E²PROM receives data, which is written internally. As the 3M line voltage

falls further to below 2.3V, voltage detect IC310 detects the voltage drop(2.3V), sets the RST port to "L" and the RST becomes active.

6-2 Battery voltage detection circuit

This divides the power supply voltage and inputs it to the microprocessor's analog port. It outputs a warning sound if the power supply voltage exceeds about 17.5~22.0V. The voltage input to the microprocessor during transmission is linked to the A/D converted LCD BATT display.

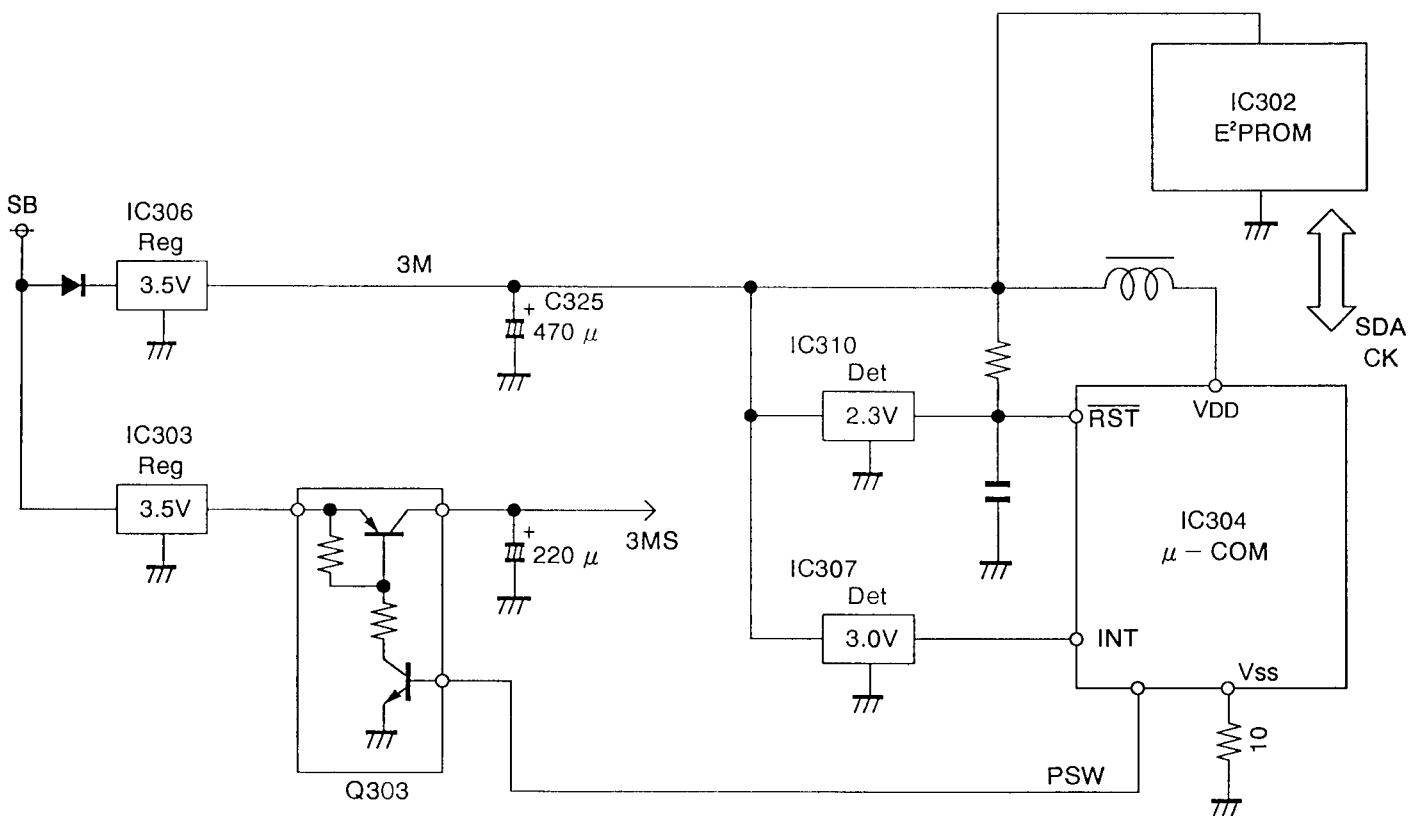

Fig. 9 Reset backup circuit

CIRCUIT DESCRIPTION

(7) Battery save circuit

- When a condition of squelch off, scan off, and no key operation input continues for 10 seconds, the battery save mode is entered.
- The signal output from the microprocessor's SAVE terminal turns Q312 on/off at a period of 200msec/800msec (200msec/200msec when DTSS basic functions are on). As

a result, each section's power supply is also turned on/off in the same fashion, reducing power consumption while in the wait mode.

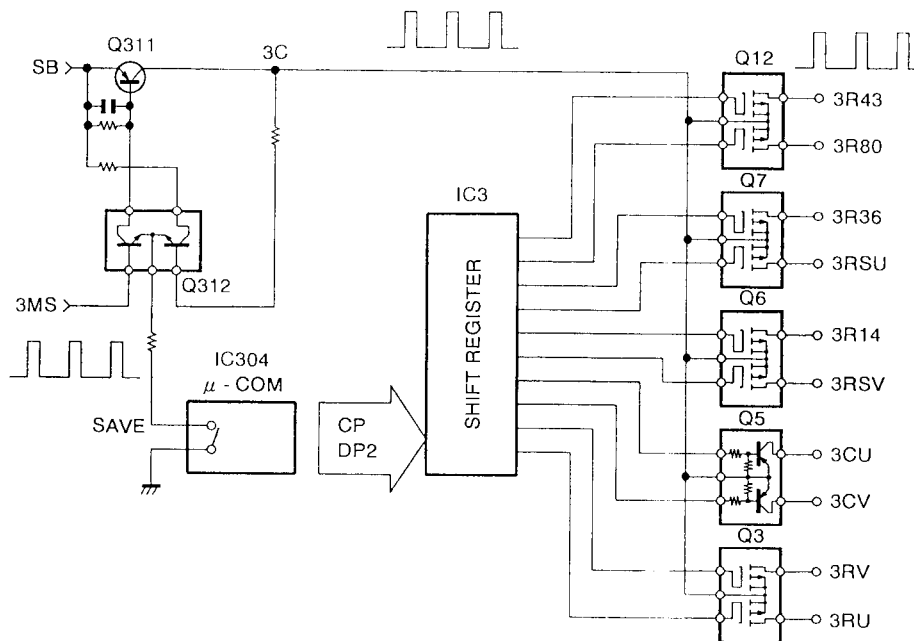

Fig. 10 Battery save circuit

(8) LED drive circuit

The LCD illumination LED is built into the LCD ASSY, and regulates the Q317 at the microprocessor port. (Fig. 11)

The TX, BUSY LEDs are controlled by pulling the cathode sides of 2 color LEDs D319 and D320 to the shift register, IC314. (Fig. 12)

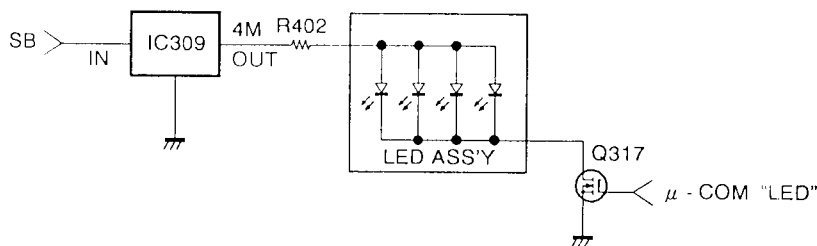

Fig. 11 LCD illumination

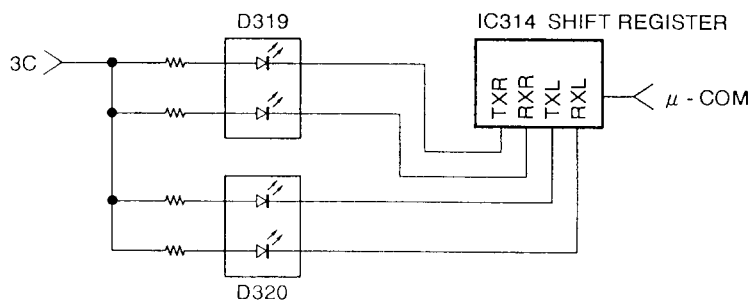

Fig. 12 LED lamp circuit during TX, BUSY

CIRCUIT DESCRIPTION

(9) Key · rotary encoder input circuit

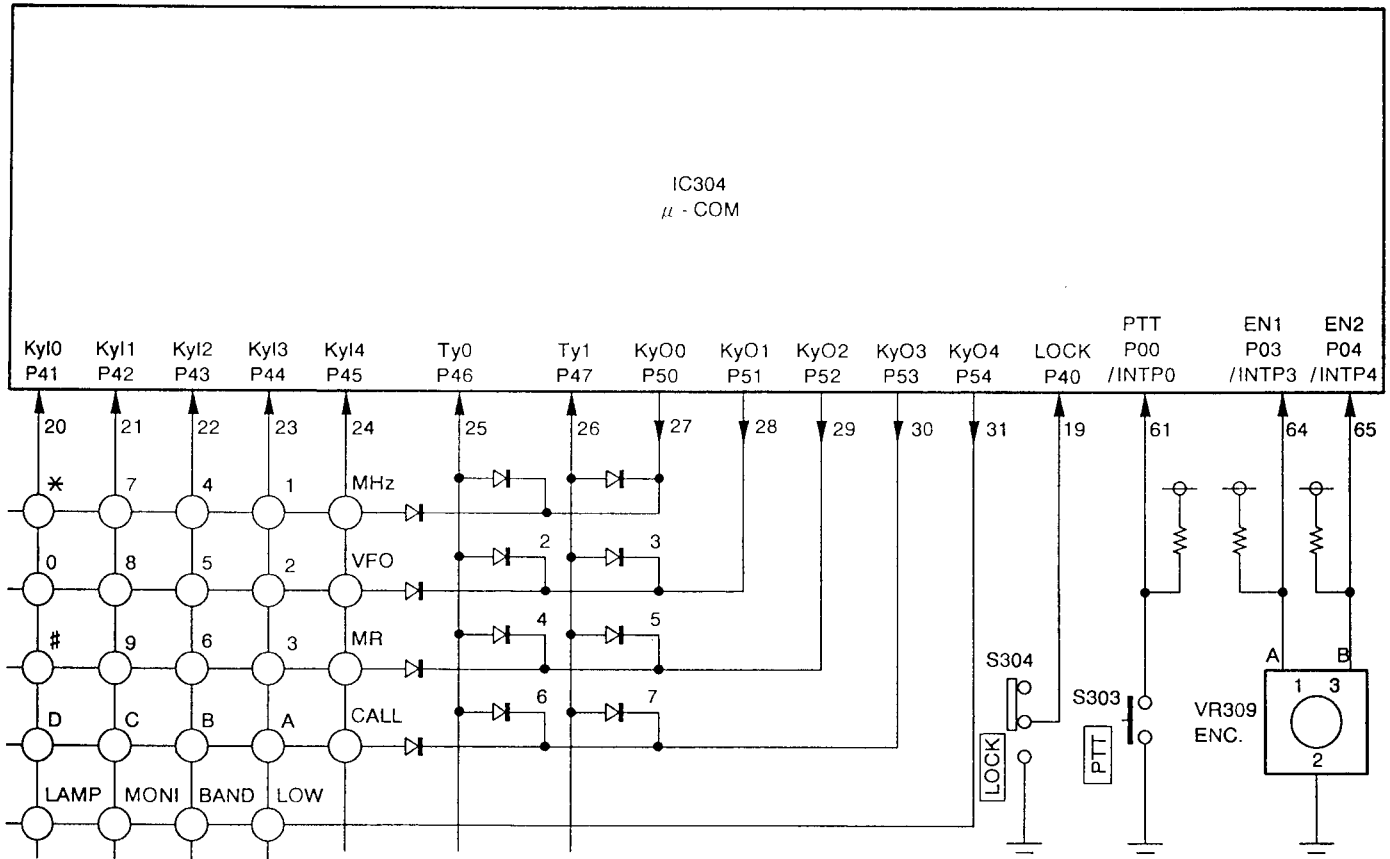

Fig. 13 Key · rotary encoder input circuit

CIRCUIT DESCRIPTION

(10) Auxiliary circuits

● CTCSS

This sets the tone frequency with data from the microprocessor (IC304). Audio input is wave detection output entered to "TSU-8" via the cross-point switch (IC11).

When the tones match, the SDO terminal turns to the "L" level. The microprocessor decides and regulates SDO terminal audio output(X-point and AFC IN, AFC EX, AI2, AE2, 3RL, 3RR each port).

During TONE signal transmission, the TONE signal is output and modulated via the LPF from the microprocessor TONE port(pin No. 5).

● DTSS

DTMF code I/O is done with serial data from the microprocessor. As with CTCSS, audio input is entered from the cross-point switch. When it detects the DTMF signal, that data is sent to the microprocessor. The microprocessor decides matching codes and regulates audio output.

During DTMF signal transmission the DTMF signal is output from the microprocessor DTMF port(pin No. 6). Microphone input is regulated by the KM terminal. The DTMF signal is modulated through the microphone amplifier. During DTMF signal transmission, the DTMF signal can be monitored from the SP, through the cross-point switch.

● DTMF decode timing

The single DTMF decode IC actuates both operated and non-operated bands. During single band operation, only the main band is checked. During dual band operation, the circuit switches to and checks the busy band. Accordingly, there may be occasions when, if both the operated and non-operated bands are busy at the same time, one band cannot be checked.

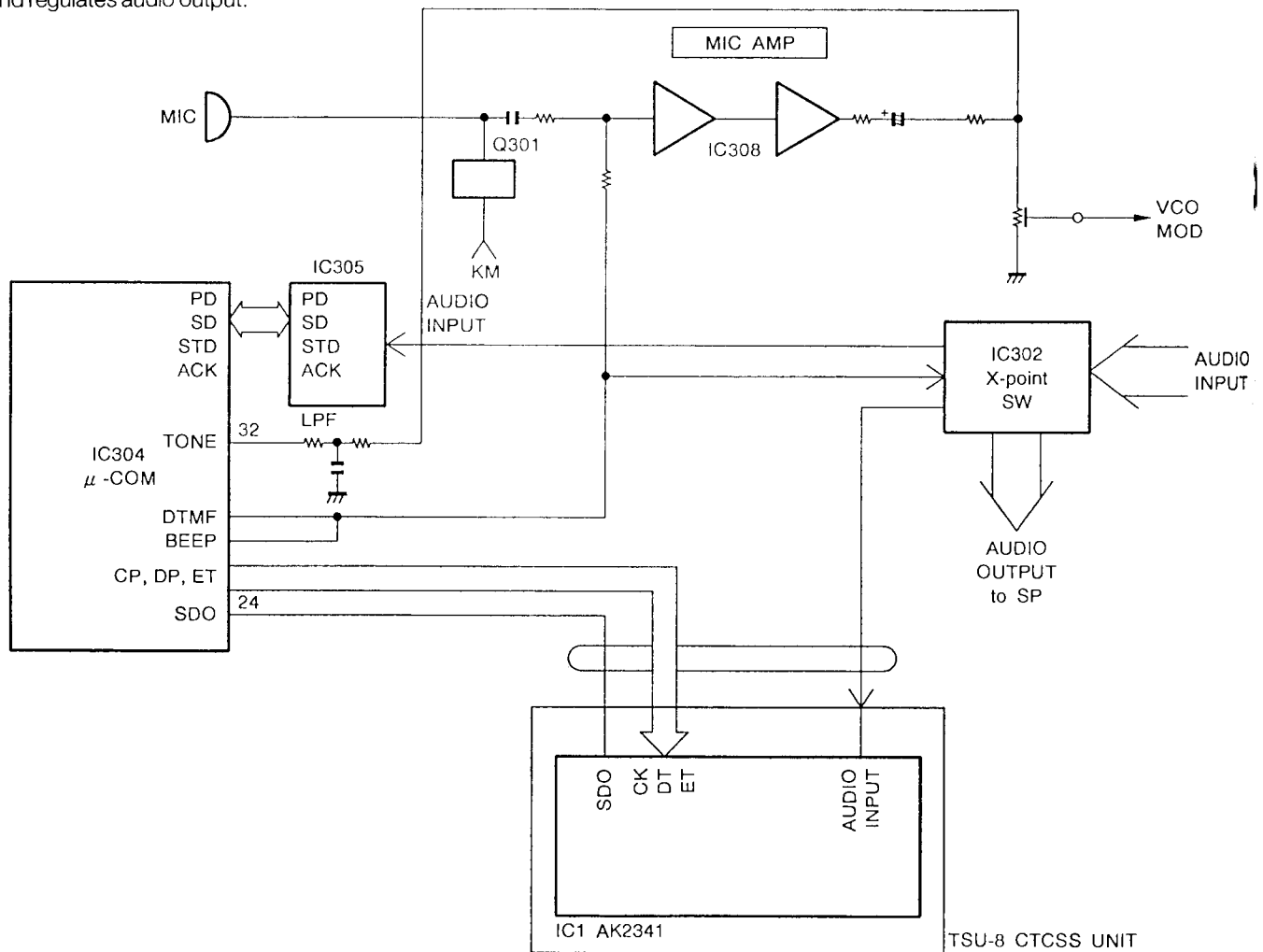

Fig. 14 Auxiliary circuit wiring diagram (DTMF, CTCSS, BEEP, TONE)

TH-79 A/E

DESCRIPTION OF COMPONENTS

Reference No.	Function	Description
IC1	FM/AM IC (VHF)	2nd mixer, quadlatcher wave detect, AF output, noise amplifier output, S meter output
IC2	FM IC (UHF)	2nd mixer, quadlatcher wave detect, AF output, noise amplifier output, S meter output
IC3	Shift register	Reception power supply regulation
IC4	PLL IC	VHF
IC5	PLL IC	UHF
IC6	Prescaler	Halves the UHF VCO output frequency and uses it for the Sub-VHF's local
IC9	VCC	UHF
IC10	VCC	VHF
IC11	Inverter	PLL reference transmission circuit
IC12	Multiplexer	VHF AF output FM/AM switch
IC100	UHF power module	
IC101	VHF power module	
IC301	DC-DC converter	Input voltage (3.5V) approximately double output
IC302	E ² PROM	16k
IC303	3.5V regulator	3MS
IC304	Microprocessor	(Refer to the I/O port specification chart)
IC305	DTMF receiver	
IC306	3.5V regulator	3M (microprocessor power supply)
IC307	3.0V detector	INT
IC308	Microphone amplifier	Limiter amplifier, active LPF
IC309	4.0V regulator	For LCD illumination
IC310	2.3V detector	RST
IC312	Cross-point switch	(Refer to the audio circuit explanation on page 6)
IC313	Multiplexer	X-Band input changeover
IC314	Shift register	Audio AVR switch, audio mute SW, APC power switching, TX/BUSY LED switch, shift SW
IC315	Audio amplifier	For internal Speaker
IC316	Audio amplifier	For external Speaker
IC317	APC differential DC amplifier	
IC318	Inverter	Prevents instantaneous LED illumination when turning on power supply(For C369 discharge)
Q1	Constant current circuit	
Q3	3RV, 3RU switch	
Q4	Tripler circuit	VHF 2nd local
Q5	3CV, 3CU switch	
Q6	3RSV, 3R14 switch	
Q7	3RSU, 3R36 switch	
Q8	IF amplifier	VHF
Q9	IF amplifier	UHF
Q10	Noise amplifier	VHF
Q11	Noise amplifier	UHF
Q12	3R80, 3R43 switch	
Q14	Ripple filter	UHF
Q16	Ripple filter	VHF
Q17	Charge pump	VHF
Q18	Charge pump	UHF
Q19	Charge pump	VHF
Q20	Charge pump	UHF
Q21	RF amplifier	UHF fin amplifier
Q22	RF amplifier	VHF fin amplifier
Q23	Band shift switch	
Q24	RF amplifier	UHF drive, 1st local dual-use
Q25	Band shift switch	
Q26	1st mixer	Main UHF
Q27	1st mixer	Main VHF
Q28	RF amplifier	UHF 1st stage drive
Q29	RF amplifier	VHF drive 1st stage

TH-79 A/E

DESCRIPTION OF COMPONENTS

Reference No.	Function	Description
Q30	Doubler circuit	Sub-UHF, 360MHz 1st local
Q31	Doubler circuit	800MHz 1st local
Q32	Temperature protection circuit	UHF only
Q33	RF amplifier	UHF drive second stage
Q34	RF amplifier	VHF drive second stage
Q35	1st mixer	Sub-VHF
Q36	RF amplifier	Main VHF reception second stage
Q37	1st mixer	800 MHz
Q38	1st mixer	Sub-UHF 360MHz
Q39	RF amplifier	Main & Sub-UHF, 360MHz reception dual-use
Q40	RF amplifier switch	VHF reception
Q41	RF amplifier	800MHz
Q42	RF amplifier	Main & Sub-UHF, VHF reception dual-use 1st stage
Q43	RF amplifier	360MHz
Q44	RF amplifier	Sub-VHF
Q301	MIC mute SW, FDP SW	Mute microphone during DTMF TX, microphone sensitivity, ATT audio output.
Q302	Audio output mute switch	External speaker
Q303	Reset circuit	
Q305	APC discharge	
Q306	3TV switch	
Q307	3TU switch	
Q308	3T switch	
Q309	3T AVR	
Q310	Buffer Amplifier(Tone)	
Q311	3C AVR	
Q312	3C switch	
Q313	Left side HPF switch	
Q314	Right side HPF switch	
Q315	Left side active HPF	
Q316	Right side active HPF	
Q317	TX/RX LED switch	
Q318	Full duplex switch	Lowers the input level of the internal speaker audio amplifier
Q319	Transmission power switch	Low power
Q320	Transmission power switch	EL, low power
Q321	Transmission power switch	EL power (UHF)
Q322	APC switch	UHF
Q323	APC switch	Q322, Q326 switch
Q324	APC switch	APCV/APCU
Q325	Transmission power switch	EL power (VHF)
Q326	APC switch	VHF
Q327	APC switch	Comparator power switch
Q328	Constant current circuit	
Q329	Differential DC amplifier	Internal
Q330	Differential DC amplifier	External
Q331	Audio AVR	Internal
Q332	Audio AVR	External
Q333	Audio AVR switch	Internal
Q334	Audio AVR switch	External
Q335	APC power supply regulation circuit	
Q336	Constant current circuit	
Q337	Modulation output band switch	
Q338	S meter temperature compensation circuit	VHF
Q339	Audio output mute switch	Internal
Q340	LED illumination prevention switch	

DESCRIPTION OF COMPONENT

Reference No.	Function	Description
D1	Constant voltage circuit	
D2	Backflow prevention	
D3	Noise rectification	VHF squelch circuit
D4	Noise rectification	UHF squelch circuit
D5	Rapid charge	UHF ripple filter
D6	Rapid charge	VHF ripple filter
D7	Waveform shaping	VHF unlock detection circuit
D8	Waveform shaping	UHF unlock detection circuit
D9	Local switch	Sub-UHF, 360MHz
D10	Local switch	Main VHF
D11	IF switch	Main UHF
D12	Local switch	Sub-VHF
D13	Band shift switch	VHF
D15	Constant voltage switch	UHF driver
D16	Local switch	800MHz
D17	Power supply switch	Sub-UHF, 360MHz doubling circuit
D18	Band shift switch	VHF
D19	IF switch	Sub-VHF
D20	Temperature protection circuit	UHF only
D21	IF switch	800MHz
D22	Band shift switch	
D23	RF switch	360MHz
D24	RF switch	Sub-UHF
D25	ANT switch	UHF
D26	ANT switch	UHF
D27	ANT switch	VHF
D28	ANT switch	UHF
D29	RF switch	Sub-UHF
D30	RF switch	360MHz
D31	ANT switch	VHF
D32	Power supply switch	VHF
D33	PLL leakage current prevention	VHF
D34	PLL leakage current prevention	UHF
D35	RF switch	Sub-UHF
D301	Startup diode	
D302	Backflow prevention (destination)	
D303	Backflow prevention (destination)	
D304	Backflow prevention (destination)	
D305	Backflow prevention (destination)	
D306	Backflow prevention (destination)	
D307	Backflow prevention (destination)	
D308	Backflow prevention (destination)	
D309	Backflow prevention (destination)	
D310	Backflow prevention (destination)	
D315	Rapid discharge	
D316	Fixed voltage circuit	
D317	Rapid discharge	
D318	Power module protection diode	
D319	LED	
D320	LED	
D321	Backflow prevention	
D322	Constant voltage circuit	Internal AF AMP AVR
D323	Constant voltage circuit	External AF AMP AVR
D324	APC switch	
D325	Waveform shaping	

TH-79 A/E

SEMICONDUCTOR DATA

Microcomputer : 78056GC-016-3B9(IC304)
: 78056GC-017-3B9(IC304)

●Pin connections

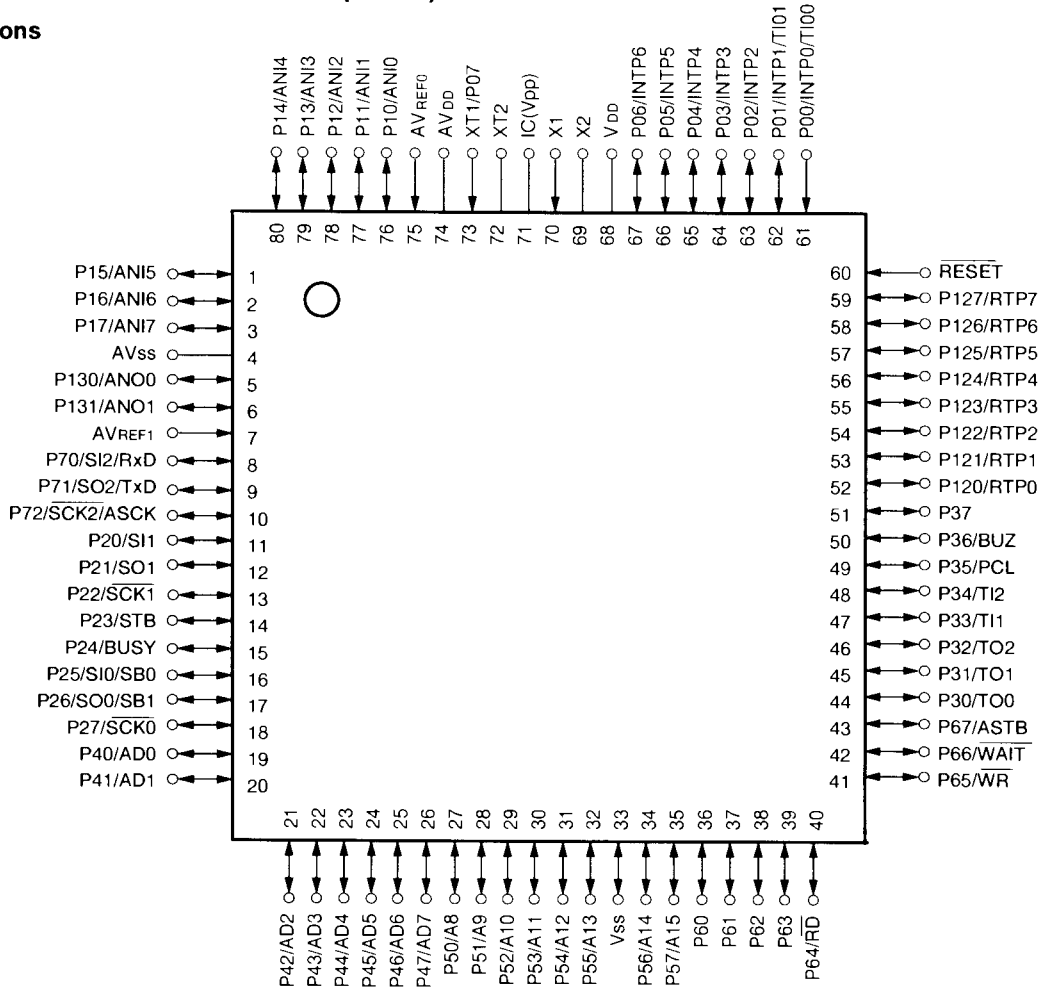

Pin No.	μ COM Port	Port Name	I/O	Pull up	Back up	Contents
1	ANI5	REM	I			Remote control switch voltage input
2	P16	ACK	O			DTMF clock output
3	P17	INH	O			CBR AF line regulation
5	ANO0	TONE	O			Sub-tone output
6	ANO1	DTMF	O			DTMF output
8	P70 RxD	ET RxD	I/O			TSU-8 enable output RS-232C reception
9	P71 TxD	SD0 TxD	I/O			TSU-8 detect input RS-232C transmission
10	P72	XLD	O			Cross-point switch LOAD
11	P20	PSW	O		L	Main power supply regulation
12	P21	3RL	O			Left VOL side high bypass filter power supply
13	P22	DS1	O			Shift register 1 (CONT side) data output
14	P23	FDP	O			Microphone & speaker attenuator
15	P24	3RR	O			Right VOL side high bypass filter power supply
16	P25	SDA	I/O			E ² PROM data in/out put
17	P26	KM	O			Microphone mute
18	P27	LED	O			Lighting illumination regulation
19	P40	LOCK	I	S		LOCK switch input
20	P41	KYIO	I	S		Key matrix input

SEMICONDUCTOR DATA

Pin No.	μ COM Port	Port Name	I/O	Pull up	Back up	Contents
21	P42	KYI1	I	S		Key matrix input
22	P43	KYI2	I	S		Key matrix input
23	P44	KYI3	I	S		Key matrix input
24	P45	KYI4	I	S		Key matrix input
25	P46	TY0	I	S		Destination input
26	P47	TYI	I	S		Destination input
27	P50	KYO0	O			Key matrix output
28	P51	KYO1	O			Key matrix output
29	P52	KYO2	O			Key matrix output
30	P53	KYO3	O			Key matrix output
31	P54	KYO4	O			Key matrix output
32	P55	DP	O			Serial data output
34	P56	CP	O			Serial lock output
35	P57	DS2	O			Shift register 2 (RF side) data
36	P60	TV	O			VHF transmission power supply control L : ACTIVE
37	P61	TU	O			UHF transmission power supply control L : ACTIVE
38	P62	TX	O		H	Transmission main power supply control L : ACTIVE
39	P63	SAVE	O		H	Save power supply regulation L : ACTIVE
40	P64	MSV	O			VHF side modulation regulation L : ACTIVE
41	P65	MSU	O			UHF side modulation regulation L : ACTIVE
42	P66	EV	O			VHF side PLL enable
43	P67	SHU	O			UHF side VCO shift switching
44	P30	ULV	I			VHF side PLL unlock detection H : LOCK
45	P31	EU	O			UHF side PLL enable H : ACTIVE
46	T02	BEEP	O			Beep sound / 1750Hz output
47	P33	SHV	O			VHF side VCO shift switching
48	P34	ULU	I			UHF side PLL unlock detection H : LOCK
49	P35	RS	O			LCD driver register selection H : DATA REGISTER RD/WR L : INSTRUCTION REGISTER WR BUSY ADDRESS R D/WR
50	P36	RW	O			LCD driver R/W selection L : WR H : RD
51	P37	ELCD	O			LCD driver enable
52	P120	DB0	I/O			LCD driver data output
53	P121	DB1	I/O			LCD driver data output
54	P122	DB2	I/O			LCD driver data output
55	P123	DB3	I/O			LCD driver data output
56	P124	DB4	I/O			LCD driver data output
57	P125	DB5	I/O			LCD driver data output
58	P126	DB6	I/O			LCD driver data output
59	P127	DB7	I/O			LCD driver data output
61	P00	PTT	I			PTT switch detection L : ACTIVE
62	P01	STD	I			DTMF detection input L : DETECT
63	INTP2	INT	I			Power supply detection L : Non-actuated mode H : actuated mode
64	INTP3	EN1	I			Encoder clock input (interrupt side)
65	P04	EN2	I			Encoder data input
66	P05	SD	I			DTMF data input
67	P06	PD	O			DTMF power down regulation L : Normal mode H : Power down
73	P07	MDT	I			External speaker connection detection L : connect
76	ANI0	BC	I			Battery voltage input
77	ANI1	SMV	I			VHF side S meter voltage input
78	ANI2	SMU	I			UHF side S meter voltage input
79	ANI3	SQV	I			VHF side SQ voltage input
80	ANI4	SQU	I			UHF side SQ voltage input

S : Pull-up resistor contact through S-software

TH-79 A/E

SEMICONDUCTOR DATA

Shift register : BU2090FS(IC3, IC314)

●Pin connection diagram

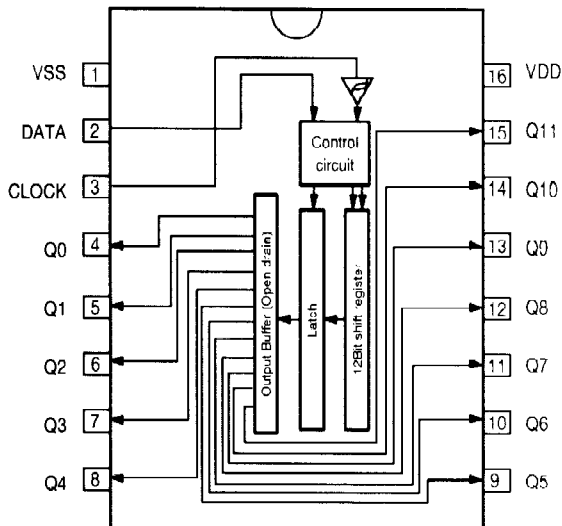

●Pin description

Pin No.	Pin Name	I/O	Description						
1	VSS		GND						
2	DATA	I	Serial data input						
3	CLOCK	I	Data shift lock (rise edge trigger) When the clock falls, if the data is "1" the shift register contents are latch output.						
4~15	Q0~Q11	O	Parallel data output (NON OPEN DRAIN FET)						
			<table border="1"> <tr> <td>Latch data</td> <td>L</td> <td>11</td> </tr> <tr> <td>Output FET</td> <td>ON</td> <td>OFF</td> </tr> </table>	Latch data	L	11	Output FET	ON	OFF
Latch data	L	11							
Output FET	ON	OFF							
16	VDD		Power supply						

DTMF decoder IC : LC73881M(IC305)

●Pin connection diagram

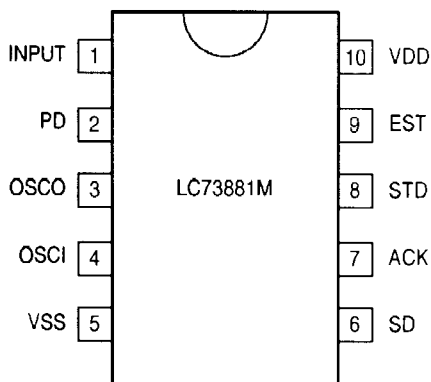

●Pin description

Pin No.	Pin Name	I/O	Description
1	INPUT	I	An input coupling condenser is required. Internally biased to VDD/2.
2	PD	I	By setting this pin to "H," power down mode is entered.
3	OSCO	O	A 4.19430MHz quartz oscillator or a ceramic generator is connected between these terminals to configure the oscillation circuit.
4	OSCI	I	
5	VSS		Power supply terminal, normally 0V
6	SD	O	Decoded DTMF output is output as 4-bit serial, led by the LSB.
7	ACK	I	The ACK pin is used to shift out data to the SD pin. Four pulses are needed to needed to shift out DTMF characters comprised by four bits. The first pulse has a function that latches data before shifting.
8	STD	O	"H" indicates the existence of a DTMF signal. Compared with the EST pin, this pin has a slower response to input signals, but it is insensitive to burst waves and the like.
9	EST	O	"H" indicates the existence of a DTMF signal. This pin provides external monitoring. After an appropriate period of time has passed, it applies four pulses to ACK to access data.
10	VDD		Power supply terminal, normally 2.7~5.5V

SEMICONDUCTOR DATA

●Block diagram

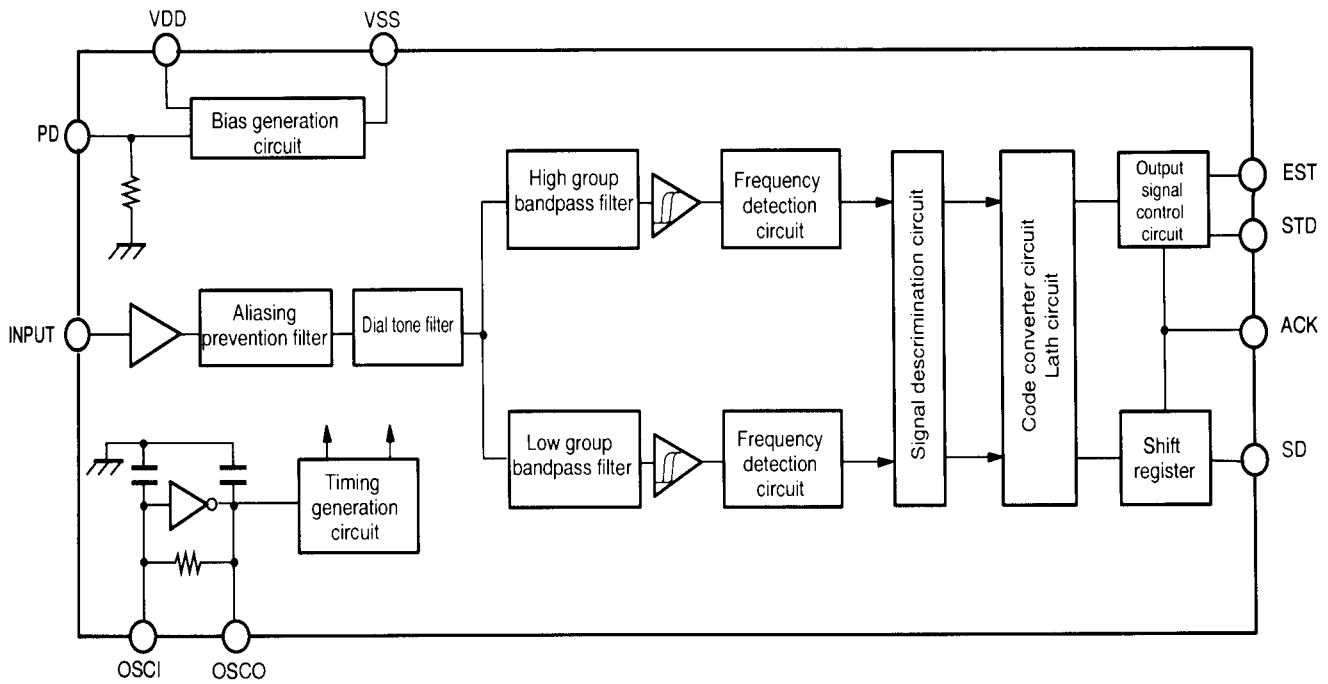

DC-DC converter : TC7660MEOA(IC301)

●Pin connection

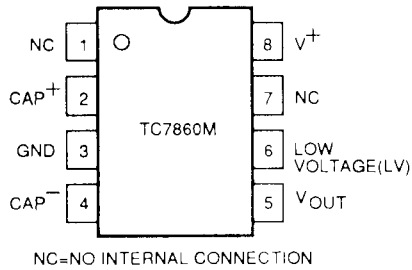

Power module : PF0310-01 : S-AU57

●Pin connection

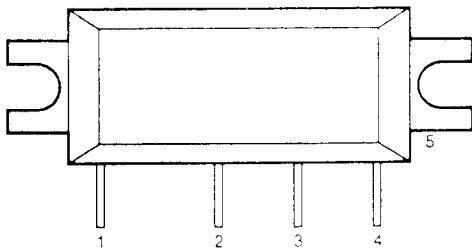

Pin assignment
 1 : Pin
 2 : V_{pc}
 3 : V_{dd}
 4 : P_{out}
 5 : GND(flange)

TH-79 A/E

PARTS LIST

* New Parts

Parts without Parts No. are not supplied.

Les articles non mentionnés dans le Parts No. ne sont pas fournis.

Teile ohne Parts No. werden nicht geliefert.

TH-79 A/E

Ref. No.	Address	New Parts	Parts No.	Description	Destination	Remarks
参照番号	位置	新	部品番号	部品名 / 規格	仕向	備考
TH-79 A/E						
1	3D	*	A01-2089-02	METALLIC CABINET(REAR)		
2	2D		A02-1784-03	PLASTIC CABINET (BT-9 FRONT)	M4X	
3	2D		A02-1785-02	PLASTIC CABINET (BT-9 REAR)	M4X	
4	1B	*	A02-1806-03	PLASTIC CABINET ASSY	KP	
4	1B	*	A02-1807-03	PLASTIC CABINET ASSY	MM2M3	
4	1B	*	A02-1807-03	PLASTIC CABINET ASSY	M4X	
4	1B	*	A02-1844-03	PLASTIC CABINET ASSY	TEE2	
4	1B	*	A02-1844-03	PLASTIC CABINET ASSY	E3E9	
5	1C	*	A13-1610-02	FRAME		
6	3C	*	A62-0334-02	PANEL (REAR)		
7	3A	*	A62-0348-13	PANEL ASSY (FRONT)		
8	1A	*	B09-0342-03	CAP (MIC/SP)		
9	1A	*	B09-0343-03	CAP (CTCSS)		
10	1B	*	B10-1214-24	FRONT GLASS		
-		*	B11-1106-04	REFLECTOR (ON AIR)		
12	2A	*	B38-0716-05	LCD ASSY		
13	1B		B42-3343-04	S/NO LABEL		
14	2D		B42-3394-14	LABEL (FCC)	K	
15	3D		B42-5074-04	LABEL (NI-CD)	K	
16	-		B42-5526-04	LABEL (HYATT)	K	
17	-		B46-0310-03	WARRANTY CARD :ACSY	E E2E3	
17	-		B46-0310-03	WARRANTY CARD :ACSY	E9	
17	-		B46-0410-30	WARRANTY CARD :ACSY	K	
17	-		B46-0422-00	WARRANTY CARD :ACSY	P	
18	-	*	B62-0423-00	INSTRUCTION MANUAL :ACSY		
19	-	*	B62-0424-00	INSTRUCTION MANUAL :ACSY	E E2	
20	-	*	B62-0425-00	INSTRUCTION MANUAL :ACSY	M M2M3	
20	-	*	B62-0425-00	INSTRUCTION MANUAL :ACSY	M4PE3	
20	-	*	B62-0425-00	INSTRUCTION MANUAL :ACSY	E9	
21	-	*	B62-0467-00	INSTRUCTION MANUAL :ACSY	M M2M3	
21	-	*	B62-0467-00	INSTRUCTION MANUAL :ACSY	M4PE3	
21	-	*	B62-0467-00	INSTRUCTION MANUAL :ACSY	E9	
22	2D		B72-0572-14	MODEL NAME PLATE (BT-9)	M4X	
23	3D	*	B72-0648-04	MODEL NAME PLATE	KP	
23	3D	*	B72-0649-04	MODEL NAME PLATE	M M2M3	
23	3D	*	B72-0649-04	MODEL NAME PLATE	M4X	
23	3D	*	B72-0650-04	MODEL NAME PLATE	TEE2E3	
23	3D		B72-0651-14	MODEL NAME PLATE	E9	
24	3C		E04-0181-05	RF COAXIAL CABLE RECEPTACLE		
25	-		E19-0254-05	PLUG :ACSY	M M2M3	
26	2D		E23-0944-04	TERMINAL (BT-9)	M4X	
27	2D		E23-0945-04	TERMINAL (BT-9)	M4X	
28	2D		E23-0946-04	TERMINAL (BT-9)	M4X	
29	2D		E23-0947-04	TERMINAL (BT-9)	M4X	
30	2D		E23-0948-04	TERMINAL (BT-9)	M4X	
31	2D		E23-0949-04	TERMINAL (BT-9)	M4X	
32	2A	*	E29-1123-05	INTER CONNECTOR (LCD ASSY)		
33	2A	*	E29-1124-05	INTER CONNECTOR (LCD ASSY)		
34	2D	*	E37-0424-05	LEAD WIRE WITH CONNECTOR		
35	1D	*	F10-2107-33	SHIELDING COVER (P MODULE)		
-			F20-1110-04	INSULATING SHEET(RF DAUGHTER)		

PARTS LIST

× New Parts

Parts without Parts No. are not supplied.

Les articles non mentionnés dans le Parts No. ne sont pas fournis.

Teile ohne Parts No. werden nicht geliefert.

TH-79 A/E

Ref. No. 参照番号	Address 位置	New Parts 新	Parts No. 部品番号	Description 部品名 / 規格	Desti- nation 仕向	Re- marks 備考
37	2C	*	F20-1145-04	INSULATING SHEET(DC IN)		
38	3B	*	F20-1155-04	INSULATING SHEET(DAUGHTER)		
-		*	F20-1159-04	INSULATING SHEET(L27,FRAME)		
39	3D		G11-0701-04	SHEET	E9	
40	2A	*	G11-0722-04	SHEET	KP	
41	3A		G13-1307-04	CUSHION		
42	2D		G13-1375-04	CUSHION (BT-9)	M4X	
43	2A	*	G13-1467-04	CUSHION (LED)		
44	1A	*	G13-1469-14	CUSHION (PANEL)		
45	1C	*	G13-1474-04	CUSHION (PANEL)		
46	3A	*	G53-0769-04	PACKING (VOL/ENC)		
47	-	*	H12-1466-03	PACKING FIXTURE	M4X	
47	-	*	H12-1467-03	PACKING FIXTURE	KM M2	
47	-	*	H12-1467-03	PACKING FIXTURE	M3TPE	
47	-	*	H12-1467-03	PACKING FIXTURE	E2E3E9	
47	-	*	H12-1468-03	PACKING FIXTURE	T	
48	-	*	H12-1471-03	PACKING FIXTURE	KM M2	
48	-	*	H12-1471-03	PACKING FIXTURE	M3PE	
48	-	*	H12-1471-03	PACKING FIXTURE	E2E3E9	
49	-	*	H12-1472-03	PACKING FIXTURE	KM M2	
49	-	*	H12-1472-03	PACKING FIXTURE	M3TPE	
49	-	*	H12-1472-03	PACKING FIXTURE	E2E3E9	
50	-	*	H13-0951-04	CARTON BOARD	E E2	
51	-	*	H13-0952-14	CARTON BOARD	KTX	
52	-		H25-0085-04	BAG	KM M2	
52	-		H25-0085-04	BAG	M3TPE	
52	-		H25-0085-04	BAG	E2E3E9	
53	-		H25-0103-04	BAG	M4X	
54	-	*	H52-0522-02	ITEM CARTON CASE	KP	
54	-	*	H52-0523-02	ITEM CARTON CASE	M M2M3	
54	-	*	H52-0524-02	ITEM CARTON CASE	TE E2	
54	-	*	H52-0524-02	ITEM CARTON CASE	E3E9	
54	-	*	H52-0608-02	ITEM CARTON CASE	M4X	
55	1D	*	J19-1552-03	HOLDER		
56	2B	*	J19-1553-13	HOLDER (KEY TOP)		
57	2A	*	J21-4456-04	HARDWARE FIXTURE(VOL/ENC)		
58	-		J29-0465-04	HOOK :ACSY		
59	-		J69-0327-04	HAND STRAP :ACSY		
60	3C	*	J69-0333-05	RING (BNC)		
61	2B	*	J82-0030-05	PRINTED FLEXIBLE BOARD		
62	3A	*	K29-4906-04	KNØB (VOL)		
63	3A	*	K29-4907-04	KNØB (ENC)		
64	3A	*	K29-4908-04	KNØB (VOL/PWR)		
65	1B	*	K29-4909-02	KNØB (PTTetc)		
66	1B	*	K29-4910-04	KNØB (LOCK)		
67	2B	*	K29-4912-03	KNØB (KEY TOP)		
A	3B	*	N09-2238-05	SCREW (M2x7)		
B	3C	*	N09-2240-05	SCREW (BELT HOOK)		
C	3C		N30-2606-46	PAN HEAD MACHINE SCREW(BNC)		
D	3C		N39-2040-45	PAN HEAD MACHINE SCREW(CASE)		
E	1C		N39-2055-46	PAN HEAD MACHINE SCREW(PCB)		
F	1C		N79-2040-46	SCREW (RF)		

TH-79 A/E

PARTS LIST

× New Parts

Parts without Parts No. are not supplied.

Les articles non mentionnés dans le Parts No. ne sont pas fournis.

Teile ohne Parts No. werden nicht geliefert.

TH-79 A/E

CTCSS UNIT (X52-3290-00) : TSU-8

Ref. No. 参照番号	Address 位置	New Parts 新	Parts No. 部品番号	Description 部品名 / 規格	Desti- nation 仕 向	Re- marks 備考
G	2B		N80-2005-46	SCREW		
H	3C		N80-2008-45	SCREW (CASE)		
I	3C	*	N80-2024-45	SCREW (CASE)		
SP	1A	*	T07-0317-05	SPEAKER		
ANT	-	*	T90-0483-05	ANTENNA : ACSY		
MIC	2B		T91-0504-05	MIC ELEMENT		
D200	2D		ERB83-004	DIORD(BT-9)	M4X	
IC101	2D		PF0310-01	IC (144MHZ POWER MODULE)		
IC100	2C		S-A057	IC (430/440MHZ POWER MODULE)		
68	-		W08-0437-05	AC ADAPTER (120V) : ACSY	KP	
68	-		W08-0438-05	AC ADAPTER (240V) : ACSY	T	
68	-		W08-0440-05	AC ADAPTER (230V) : ACSY	E E2E3	
68	-		W08-0440-05	AC ADAPTER (230V) : ACSY	B9	
68	-		W08-0441-05	AC ADAPTER (120/230V) : ACSY	M M2M3	
69	-		W09-0825-15	BATTERY ASSY(PB-34) : ACSY	M3	
69	-		W09-0826-05	BATTERY ASSY(PB-32) : ACSY	KM M2T	
69	-		W09-0826-05	BATTERY ASSY(PB-32) : ACSY	PE E2	
69	-		W09-0826-05	BATTERY ASSY(PB-32) : ACSY	E3E9	
70	2A	*	X52-3290-00	CTCSS UNIT (OPTION...TSU-8)	KP	
700	-	*	X57-4400-11	TX-RX UNIT (A/7...G/7)	KP	
700	-	*	X57-4400-21	TX-RX UNIT (A/7...G/7)	M	
700	-	*	X57-4400-22	TX-RX UNIT (A/7...G/7)	M2M3M4	
700	-	*	X57-4400-71	TX-RX UNIT (A/7...G/7)	X	
700	-	*	X57-4402-71	TX-RX UNIT (A/7...G/7)	TE	
700	-	*	X57-4402-72	TX-RX UNIT (A/7...G/7)	E2	
700	-	*	X57-4402-73	TX-RX UNIT (A/7...G/7)	E3E9	
CTCSS UNIT (X52-3290-00) : TSU-8						
C1			CK73HB1C103K	CHIP C 0.01UF K	KP	
C2			CK73HB1E102K	CHIP C 1000PF K	KP	
C3 ,4			CC73HCH1E220J	CHIP C 22PF J	KP	
C5			CK73HB1C103K	CHIP C 0.01UF K	KP	
C6 ,7			CK73PF1C105Z	CHIP C 1.0UF Z	KP	
C8			C92-0507-05	CHIP TAN 4.7UF 6.3WV	KP	
C9			CC73HCH1E101J	CHIP C 100PF J	KP	
C10			CK73FB1E104K	CHIP C 0.10UF K	KP	
C11			CK73HB1E102K	CHIP C 1000PF K	KP	
C12			CK73GR1C473K	CHIP C 0.047UF K	KP	
X1			L77-1530-05	CRYSTAL RESONATOR(3.6864MHZ)	KP	
R1			RK73HB1J563J	CHIP R 56K J 1/16W	KP	
R2			RK73HB1J473J	CHIP R 47K J 1/16W	KP	
R3			RK73HB1J224J	CHIP R 220K J 1/16W	KP	
R4			RK73HB1J101J	CHIP R 100 J 1/16W	KP	
R5			RK73HB1J105J	CHIP R 1M J 1/16W	KP	
R6			RK73HB1J274J	CHIP R 270K J 1/16W	KP	
R7			RK73HB1J101J	CHIP R 100 J 1/16W	KP	
R8			RK73HB1J562J	CHIP R 5.6K J 1/16W	KP	
R9			RK73HB1J333J	CHIP R 33K J 1/16W	KP	
R10			RK73HB1J123J	CHIP R 12K J 1/16W	KP	
R11			RK73HB1J104J	CHIP R 100K J 1/16W	KP	
R12			RK73HB1J822J	CHIP R 8.2K J 1/16W	KP	
R13			RK73HB1J682J	CHIP R 6.8K J 1/16W	KP	

PARTS LIST

× New Parts

Parts without Parts No. are not supplied.

Les articles non mentionnés dans le Parts No. ne sont pas fournis.

Teile ohne Parts No. werden nicht geliefert.

CTCSS UNIT (X52-3290-00) : TSU-8

TX-RX UNIT(X57-440X-XX)

Ref. No. 参照番号	Address 位置	New Parts 新	Parts No. 部品番号	Description 部品名 / 規格	Desti- nation 仕向	Re- marks 備考
R14			R92-1252-05	CHIP R 0 0HM	KP	
R15			R92-1368-05	CHIP R 0 0HN 1/16W	KP	
R16 ,17			RK73HB1J473J	CHIP R 47K J 1/16W	KP	
IC1			AK2341	IC	KP	
TX-RX UNIT(X57-440X-XX)						
C1			CK73HB1C103K	CHIP C 0.01UF K		
C2 ,3			CK73FB1E104K	CHIP C 0.10UF K		
C4		*	CC73HCH1E150J	CHIP C 15PF J		
C5		*	CC73HCH1E270J	CHIP C 27PF J		
C6		*	CC73HCH1E820J	CHIP C 82PF J		
C7 -9			CK73FB1E104K	CHIP C 0.10UF K		
C10			CK73HB1C103K	CHIP C 0.01UF K		
C11		*	CC73HCH1E680J	CHIP C 68PF J		
C12		*	CC73HCH1E820J	CHIP C 82PF J		
C13			CC73HCH1E101J	CHIP C 100PF J		
C14 ,15			CK73FB1E104K	CHIP C 0.10UF K		
C16		*	CC73HCH1E180J	CHIP C 18PF J		
C17		*	CC73HCH1E270J	CHIP C 27PF J		
C18		*	CC73HCH1E390J	CHIP C 39PF J		
C19			CK73FB1E104K	CHIP C 0.10UF K		
C20 ,21			CK73HB1C103K	CHIP C 0.01UF K		
C22 ,23			CK73HB1E471K	CHIP C 470PF K		
C24			CK73GB1H471K	CHIP C 470PF K		
C25			CK73HB1C103K	CHIP C 0.01UF K		
C26			C92-0576-05	TANTAL 1UF 6.3WV		
C27			CK73GR1C333K	CHIP C 0.033UF K		
C28			CK73GR1C473K	CHIP C 0.047UF K		
C29			CK73HB1C103K	CHIP C 0.01UF K		
C30			CK73FB1E104K	CHIP C 0.10UF K		
C31			CK73HB1E471K	CHIP C 470PF K		
C32		*	CC73HCH1E120J	CHIP C 12PF J		
C33			CC73GCH1H070D	CHIP C 7PF D		
C34			CK73GR1C473K	CHIP C 0.047UF K		
C35 -40			CK73HB1E471K	CHIP C 470PF K		
C41			CK73HB1E102K	CHIP C 1000PF K		
C42 ,43			CK73HB1E471K	CHIP C 470PF K		
C44			CK73GB1H152K	CHIP C 1500PF K		
C45			CK73GR1C333K	CHIP C 0.033UF K		
C46			C92-0576-05	TANTAL 1UF 6.3WV		
C47			CK73GB1H152K	CHIP C 1500PF K		
C48			CK73GR1C333K	CHIP C 0.033UF K		
C49			C92-0576-05	TANTAL 1UF 6.3WV		
C50			CC73GCH1H050C	CHIP C 5PF C		
C51			CC73GCH1H080D	CHIP C 8PF D		
C52 ,53			CK73GR1C333K	CHIP C 0.033UF K		
C54 -57			CK73HB1C103K	CHIP C 0.01UF K		
C58			CK73HB1E102K	CHIP C 1000PF K		
C59			CK73HB1E471K	CHIP C 470PF K		
C60		*	C92-0542-05	CHIP TAN 0.1UF 20WV		
C61			CK73HB1E471K	CHIP C 470PF K		
C63			CK73HB1E471K	CHIP C 470PF K		
C64		*	C92-0542-05	CHIP TAN 0.1UF 20WV		
C65			CK73GR1C473K	CHIP C 0.047UF K		
C67			CK73HB1C103K	CHIP C 0.01UF K		

TH-79 A/E

PARTS LIST

× New Parts

Parts without Parts No. are not supplied.

Les articles non mentionnes dans le Parts No. ne sont pas fournis.

Teile ohne Parts No. werden nicht geliefert.

TX-RX UNIT(X57-440X-XX)

Ref. No. 参照番号	Address 位置	New Parts 新	Parts No. 部品番号	Description 部品名 / 規格	Desti- nation 仕 向	Re- marks 備考
C68			CK73HB1E471K	CHIP C 470PF K		
C69			C92-0507-05	CHIP TAN 4.7UF 6.3WV		
C70 -72			CK73GR1C473K	CHIP C 0.047UF K		
C73			CK73HB1E471K	CHIP C 470PF K		
C74			C92-0507-05	CHIP TAN 4.7UF 6.3WV		
C75		*	CC73HCH1E030C	CHIP C 3PF C		
C76			C92-0507-05	CHIP TAN 4.7UF 6.3WV		
C77			C92-0566-05	TANTAL 10UF 6.3WV		
C78 ,79			CK73HB1E471K	CHIP C 470PF K		
C80			C92-0507-05	CHIP TAN 4.7UF 6.3WV		
C81			CK73HB1E102K	CHIP C 1000PF K		
C82 ,83			CK73HB1E471K	CHIP C 470PF K		
C84			CK73GR1C473K	CHIP C 0.047UF K		
C85			CK73HB1E102K	CHIP C 1000PF K		
C86		*	C92-0542-05	CHIP TAN 0.1UF 20WV		
C87			C92-0587-05	TANTAL 2.2UF 4WV		
C88			CK73HB1C103K	CHIP C 0.01UF K		
C89 ,90			CK73HB1E471K	CHIP C 470PF K		
C91		*	CC73HCH1E030C	CHIP C 3PF C		
C92			CK73HB1C103K	CHIP C 0.01UF K		
C93		*	CC73HCH1E470J	CHIP C 47PF J		
C94			CK73HB1C103K	CHIP C 0.01UF K		
C95		*	CC73HCH1E050C	CHIP C 5PF C		
C96		*	CC73HCH1E030C	CHIP C 3PF C		
C97			CK73HB1E102K	CHIP C 1000PF K		
C98			CC73GCH1H070D	CHIP C 7PF D		
C99		*	CC73HCH1E180J	CHIP C 18PF J		
C100			CK73HB1E471K	CHIP C 470PF K		
C101		*	CC73HCH1E050C	CHIP C 5PF C		
C102		*	CC73HCH1E030C	CHIP C 3PF C	XTMM1	
C102		*	CC73HCH1E030C	CHIP C 3PF C	M3M4E	
C102		*	CC73HCH1E050C	CHIP C 5PF C	E2E3E9	
C103			CK73HB1C103K	CHIP C 0.01UF K	KP	
C104		*	CC73HCH1E120J	CHIP C 12PF J		
C105			CK73HB1C103K	CHIP C 0.01UF K		
C106			CC73HCH1E010C	CHIP C 1PF C		
C107			CK73HB1E471K	CHIP C 470PF K		
C108			CC73HCH1E101J	CHIP C 100PF J		
C109			CK73HB1E102K	CHIP C 1000PF K		
C110			CC73HCH1E101J	CHIP C 100PF J		
C111			CK73HB1E471K	CHIP C 470PF K		
C113, 114			CK73HB1E102K	CHIP C 1000PF K		
C115			CK73HB1E471K	CHIP C 470PF K		
C116			CC73GCH1H070D	CHIP C 7PF D		
C117-119			CK73HB1E102K	CHIP C 1000PF K		
C120			CK73HB1E471K	CHIP C 470PF K	XTMM2	
C120			CK73HB1E471K	CHIP C 470PF K	M3M4E	
C120			CK73HB1E471K	CHIP C 470PF K	E2E3E9	
C121			CK73FB1E104K	CHIP C 0.10UF K		
C122		*	CC73HCH1E680J	CHIP C 68PF J		
C123			CK73GB1H102K	CHIP C 1000PF K		
C124			CK73HB1E102K	CHIP C 1000PF K		
C125			CC73GCH1H220J	CHIP C 22PF J		
C126			CK73HB1E102K	CHIP C 1000PF K		

PARTS LIST

× New Parts

Parts without Parts No. are not supplied.

Les articles non mentionnés dans le Parts No. ne sont pas fournis.

Teile ohne Parts No. werden nicht geliefert.

TX-RX UNIT(X57-440X-XX)

Ref. No. 参照番号	Address 位置	New Parts 新	Parts No. 部品番号	Description 部品名 / 規格	Desti- nation 仕 向	Re- marks 備考
C127			CK73HB1E471K	CHIP C 470PF K		
C128		*	CC73HCH1E120J	CHIP C 12PF J		
C129		*	CC73HCH1E680J	CHIP C 68PF J		
C130, 131			CK73HB1E471K	CHIP C 470PF K		
C132		*	CC73HCH1E120J	CHIP C 12PF J		
C134		*	CC73HCH1E060D	CHIP C 6PF D		
C135			CC73GCH1H030C	CHIP C 3PF C		
C136			CK73HB1E471K	CHIP C 470PF K		
C137			CC73HCH1E100D	CHIP C 10PF D		
C138			CC73HCH1E101J	CHIP C 100PF J	XTMM2	
C138			CC73HCH1E101J	CHIP C 100PF J	M3M4E	
C138			CC73HCH1E101J	CHIP C 100PF J	E2E3E9	
C139		*	CC73HCH1E150J	CHIP C 15PF J		
C140			CK73HB1C103K	CHIP C 0.01UF K		
C141			CK73GB1H471K	CHIP C 470PF K		
C142			CC73HCH1E080D	CHIP C 8PF D		
C143			CC73HCH1E101J	CHIP C 100PF J	XTMM2	
C143			CC73HCH1E101J	CHIP C 100PF J	M3M4E	
C143			CC73HCH1E101J	CHIP C 100PF J	E2E3E9	
C144			CK73HB1E102K	CHIP C 1000PF K		
C146		*	CC73HCH1E030C	CHIP C 3PF C		
C147			CK73HB1E471K	CHIP C 470PF K		
C148			CK73HB1E102K	CHIP C 1000PF K		
C149			CC73HCH1E080D	CHIP C 8PF D		
C150			CK73HB1E471K	CHIP C 470PF K		
C151		*	CC73HCH1E020C	CHIP C 2PF C	XTMM2	
C151		*	CC73HCH1E020C	CHIP C 2PF C	M3M4E	
C151		*	CC73HCH1E020C	CHIP C 2PF C	E2E3E9	
C152			CC73HCH1E080D	CHIP C 8PF D		
C153			CK73HB1E102K	CHIP C 1000PF K		
C154			CK73HB1C103K	CHIP C 0.01UF K	XTMM2	
C154			CK73HB1C103K	CHIP C 0.01UF K	M3M4E	
C154			CK73HB1C103K	CHIP C 0.01UF K	E2E3E9	
C155			CC73HCH1E010C	CHIP C 1PF C		
C157		*	CC73HCH1E030C	CHIP C 3PF C		
C158			CK73HB1C103K	CHIP C 0.01UF K		
C159			CK73HB1E471K	CHIP C 470PF K		
C160			CK73HB1E102K	CHIP C 1000PF K		
C161			CK73GB1H102K	CHIP C 1000PF K		
C162			CC73HCH1E080D	CHIP C 8PF D		
C163		*	CC73HCH1E330J	CHIP C 33PF J		
C165		*	CC73HCH1E680J	CHIP C 68PF J		
C168			CC73HCH1E220J	CHIP C 22PF J		
C169, 170			CK73HB1E471K	CHIP C 470PF K		
C171			CC73HCH1E010C	CHIP C 1PF C		
C172			C92-0585-05	TANTAL 4.7UF 16VV		
C173			CK73HB1E471K	CHIP C 470PF K		
C174			CC73HCH1E040C	CHIP C 4PF C		
C175		*	CC73HCH1E330J	CHIP C 33PF J		
C176			CK73HB1C103K	CHIP C 0.01UF K		
C177			CK73HB1E471K	CHIP C 470PF K		
C178		*	CC73HCH1E030C	CHIP C 3PF C	XTMM2	
C178		*	CC73HCH1E030C	CHIP C 3PF C	M3M4E	
C178		*	CC73HCH1E030C	CHIP C 3PF C	E2E3E9	
C179			CK73HB1C103K	CHIP C 0.01UF K		

TH-79 A/E

PARTS LIST

× New Parts

Parts without Parts No. are not supplied.

Les articles non mentionnés dans le Parts No. ne sont pas fournis.

Teile ohne Parts No. werden nicht geliefert.

TX-RX UNIT(X57-440X-XX)

Ref. No. 参照番号	Address 位置	New Parts 新	Parts No. 部品番号	Description 部品名 / 規格	Desti- nation 仕向	Re- marks 備考
C180			CK73HB1E102K	CHIP C 1000PF K		
C181			CK73HB1E471K	CHIP C 470PF K		
C182		*	CC73HCH1E150J	CHIP C 15PF J		
C183		*	CC73HCH1E060D	CHIP C 6PF D		
C184			CK73HB1E102K	CHIP C 1000PF K		
C185			CK73HB1E471K	CHIP C 470PF K		
C186			CC73HCH1E100D	CHIP C 10PF D		
C187			CK73HB1E471K	CHIP C 470PF K		
C188			CC73HCH1E040C	CHIP C 4PF C	XTMM2	
C188			CC73HCH1E040C	CHIP C 4PF C	M3M4E	
C188			CC73HCH1E040C	CHIP C 4PF C		E2E3E9
C189			CC73HCH1E220J	CHIP C 22PF J		
C190			CK73GR1C473K	CHIP C 0.047UF K		
C191		*	CC73HCH1E030C	CHIP C 3PF C		
C192		*	CC73HCH1E470J	CHIP C 47PF J		
C193			CK73GB1H103K	CHIP C 0.01UF K		
C194			CK73HB1E471K	CHIP C 470PF K		
C195			CK73GB1H103K	CHIP C 0.01UF K		
C196			CK73HB1E102K	CHIP C 1000PF K		
C197			CC73HCH1E101J	CHIP C 100PF J		
C198			CK73HB1E102K	CHIP C 1000PF K		
C199		*	CC73HCH1E470J	CHIP C 47PF J		
C200			CK73HB1E102K	CHIP C 1000PF K		
C201		*	CC73HCH1E070D	CHIP C 7PF D		
C202			CC73HCH1E100D	CHIP C 10PF D		
C203		*	CC73HCH1E120J	CHIP C 12PF J		
C204			CC73HCH1E080D	CHIP C 8PF D		
C205		*	CC73HCH1E330J	CHIP C 33PF J		
C206		*	CC73HCH1E060D	CHIP C 6PF D		
C208			CK73HB1E102K	CHIP C 1000PF K		
C209			CC73GCH1H030C	CHIP C 3PF C		
C210			CC73GCH1H020C	CHIP C 2.0PF C		
C211			CK73HB1E471K	CHIP C 470PF K		
C212		*	CC73HCH1E030C	CHIP C 3PF C		
C213, 214			CK73HB1E102K	CHIP C 1000PF K		
C215		*	CC73HCH1E120J	CHIP C 12PF J		
C216		*	CC73HCH1E030C	CHIP C 3PF C		
C217			CC73GCH1H020C	CHIP C 2.0PF C	KP	
C218			CC73GCH1H040C	CHIP C 4PF C		
C221		*	CC73HCH1E070D	CHIP C 7PF D		
C222			CC73GCH1H1R5C	CHIP C 1.5PF C	XTMM2	
C222			CC73GCH1H1R5C	CHIP C 1.5PF C	M3M4E	
C222			CC73GCH1H1R5C	CHIP C 1.5PF C	E2E3E9	
C223			CC73GCH1H180J	CHIP C 18PF J		
C224			CC73HCH1E080D	CHIP C 8PF D		
C225			CK73HB1E102K	CHIP C 1000PF K		
C226			CC73GCH1H050C	CHIP C 5PF C		
C227			CC73GCH1H1R5C	CHIP C 1.5PF C	XTMM2	
C227			CC73GCH1H1R5C	CHIP C 1.5PF C	M3M4E	
C227			CC73GCH1H1R5C	CHIP C 1.5PF C	E2E3E9	
C228			CC73GCH1H030C	CHIP C 3PF C	KP	
C228			CC73GCH1H060D	CHIP C 6PF D	XTMM2	
C228			CC73GCH1H060D	CHIP C 6PF D	M3M4E	
C228			CC73GCH1H060D	CHIP C 6PF D	E2E3E9	
C229			CC73HCH1E100D	CHIP C 10PF D		

TH-79 A/E

PARTS LIST

× New Parts

Parts without Parts No. are not supplied.

Les articles non mentionnés dans le Parts No. ne sont pas fournis.

Teile ohne Parts No. werden nicht geliefert.

TX-RX UNIT(X57-440X-XX)

Ref. No. 参照番号	Address 位置	New Parts 新	Parts No. 部品番号	Description 部品名 / 規格	Desti- nation 仕向	Re- marks 備考
C230		*	CC73HCH1E150J	CHIP C 15PF J		
C231		*	CC73HCH1E330J	CHIP C 33PF J		
C232			CC73GCH1H020C	CHIP C 2.0PF C	KP	
C232			CC73GCH1H1R5C	CHIP C 1.5PF C	XTMM2	
C232			CC73GCH1H1R5C	CHIP C 1.5PF C	M3M4E	
C232			CC73GCH1H1R5C	CHIP C 1.5PF C	E2E3E9	
C234			CC73GCH1H080D	CHIP C 8PF D		
C235			CC73GCH1H270J	CHIP C 27PF J		
C236			CC73GCH1H050C	CHIP C 5PF C		
C237			CK73GB1H102K	CHIP C 1000PF K		
C238		*	CC73HCH1E150J	CHIP C 15PF J		
C239			CK73HB1E471K	CHIP C 470PF K		
C240		*	CC73HCH1E120J	CHIP C 12PF J		
C242			CK73HB1E471K	CHIP C 470PF K	XTMM2	
C242			CK73HB1E471K	CHIP C 470PF K	M3M4E	
C242			CK73HB1E471K	CHIP C 470PF K	E2E3E9	
C243			CK73HB1E471K	CHIP C 470PF K		
C244			CK73FB1E104K	CHIP C 0.10UF K		
C245			CK73FB1E471K	CHIP C 470PF K		
C246			CK73FB1E102K	CHIP C 1000PF K		
C247			CK73HB1C103K	CHIP C 0.01UF K		
C250		*	C92-0602-05	TANTAL 1UF 10WV		
C251			CC73HCH1E080D	CHIP C 8PF D		
C301, 302			C92-0565-05	TANTAL 6.8UF 10WV		
C303			C92-0587-05	TANTAL 2.2UF 4WV		
C304			CK73HB1E102K	CHIP C 1000PF K		
C305			CK73HB1C103K	CHIP C 0.01UF K		
C306			CK73GB1H103K	CHIP C 0.01UF K		
C307		*	CC73HCH1E390J	CHIP C 39PF J		
C308			CK73HB1C103K	CHIP C 0.01UF K		
C309-311			CK73HB1E471K	CHIP C 470PF K		
C312			C92-0002-05	CHIP TAN 0.22UF 35WV		
C313		*	CC73HCH1E390J	CHIP C 39PF J		
C314			CC73HCH1E101J	CHIP C 100PF J		
C315			CK73HB1C103K	CHIP C 0.01UF K		
C316			CK73GB1E223K	CHIP C 0.022UF K		
C317			C92-0587-05	TANTAL 2.2UF 4WV		
C318			CK73HB1C103K	CHIP C 0.01UF K		
C319			CK73GB1H471K	CHIP C 470PF K		
C320			C92-0587-05	TANTAL 2.2UF 4WV		
C321-324			CK73HB1E471K	CHIP C 470PF K		
C325			C90-4017-05	ELECTRON 470UF 4WV		
C326		*	CK73HB1E182K	CHIP C 1800PF K		
C327			CC73GCH1H151J	CHIP C 150PF J		
C328			CK73GB1H471K	CHIP C 470PF K		
C329			C92-0587-05	TANTAL 2.2UF 4WV		
C330			CK73GB1H103K	CHIP C 0.01UF K		
C331			CK73HB1E471K	CHIP C 470PF K		
C332			C92-0507-05	CHIP TAN 4.7UF 6.3WV		
C333			CK73GB1C104K	CHIP C 0.10UF K		
C335			C92-0564-05	ELECTRON 22UF 6.3WV		
C336			CK73HB1E471K	CHIP C 470PF K		
C337			C92-0576-05	TANTAL 1UF 6.3WV		
C338			CK73HB1E471K	CHIP C 470PF K		
C339			CK73HB1E102K	CHIP C 1000PF K		

TH-79 A/E

PARTS LIST

× New Parts

Parts without Parts No. are not supplied.

Les articles non mentionnés dans le Parts No. ne sont pas fournis.

Teile ohne Parts No. werden nicht geliefert.

TX-RX UNIT(X57-440X-XX)

Ref. No. 参照番号	Address 位置	New Parts 新	Parts No. 部品番号	Description 部品名 / 規格	Desti- nation 仕向	Re- marks 備考
C340			C92-0576-05	TANTAL 1UF 6.3WV		
C342			CK73GB1H103K	CHIP C 0.01UF K		
C343			CK73HB1E471K	CHIP C 470PF K		
C344		*	C92-0594-05	TANTAL 4.7UF 4WV		
C345			CK73GB1H103K	CHIP C 0.01UF K		
C346,347			CK73GB1H471K	CHIP C 470PF K		
C348			CK73HB1C103K	CHIP C 0.01UF K		
C349			CK73GB1H103K	CHIP C 0.01UF K		
C350			C92-0564-05	ELECTRØ 22UF 6.3WV		
C351			CK73HB1E471K	CHIP C 470PF K		
C352		*	C92-0594-05	TANTAL 4.7UF 4WV		
C353			CK73HB1E471K	CHIP C 470PF K		
C354			CK73GR1C333K	CHIP C 0.033UF K		
C355			CK73HB1E471K	CHIP C 470PF K		
C356-358			CK73GR1C473K	CHIP C 0.047UF K		
C359		*	C92-0618-05	ELECTRØ 10UF 16WV		
C360			CK73GB1H471K	CHIP C 470PF K		
C361			CK73GR1C333K	CHIP C 0.033UF K		
C362			CK73GB1H471K	CHIP C 470PF K		
C363			CK73HB1E471K	CHIP C 470PF K		
C364			CK73GR1C333K	CHIP C 0.033UF K		
C365,366			CK73HB1E471K	CHIP C 470PF K		
C367,368			CK73GR1C333K	CHIP C 0.033UF K		
C369			C92-0564-05	ELECTRØ 22UF 6.3WV		
C370,371			CK73HB1E471K	CHIP C 470PF K		
C372,373			C92-0587-05	TANTAL 2.2UF 4WV		
C374,375			CK73GR1C473K	CHIP C 0.047UF K		
C376,377			CK73HB1C103K	CHIP C 0.01UF K		
C378			CK73GB1H103K	CHIP C 0.01UF K		
C379			CK73HB1E471K	CHIP C 470PF K		
C380,381			C92-0566-05	TANTAL 10UF 6.3WV		
C382,383			C92-0593-05	ELECTRØ 33UF 10WV		
C384			CK73HB1E471K	CHIP C 470PF K		
C385,386			CK73GR1C473K	CHIP C 0.047UF K		
C387			C92-0567-05	TANTAL 68UF 6.3WV		
C388-391			CK73HB1E471K	CHIP C 470PF K		
C392,393			CK73GB1H471K	CHIP C 470PF K		
C394,395			C92-0576-05	TANTAL 1UF 6.3WV		
C396-400			CK73HB1E471K	CHIP C 470PF K		
C401			CK73HCH1E101J	CHIP C 100PF J		
C402-404			CK73HB1E471K	CHIP C 470PF K		
C405			CK73GB1H471K	CHIP C 470PF K		
C407			CK73GB1E223K	CHIP C 0.022UF K		
C408		*	C92-0594-05	TANTAL 4.7UF 4WV		
C409			C92-0567-05	TANTAL 68UF 6.3WV		
C410			CK73GB1H471K	CHIP C 470PF K		
C411-415			CK73HB1E471K	CHIP C 470PF K		
C416			CK73GB1H471K	CHIP C 470PF K		
C417			CK73HB1E471K	CHIP C 470PF K		
C418,419			CK73GB1H471K	CHIP C 470PF K		
C420			CK73HB1E471K	CHIP C 470PF K		
C421			C92-0565-05	TANTAL 6.8UF 10WV		
C422,423			CK73HB1E471K	CHIP C 470PF K		
C424			CK73HB1C103K	CHIP C 0.01UF K		
C425			CK73GB1H471K	CHIP C 470PF K		

PARTS LIST

× New Parts

Parts without Parts No. are not supplied.

Les articles non mentionnes dans le Parts No. ne sont pas fournis.

Teile ohne Parts No. werden nicht geliefert.

TX-RX UNIT(X57-440X-XX)

Ref. No. 参照番号	Address 位置	New Parts 新	Parts No. 部品番号	Description 部品名 / 規格	Desti- nation 仕 向	Re- marks 備考
C426			CK73HB1E471K	CHIP C 470PF K		
C427			CK73GR1C473K	CHIP C 0.047UF K		
C428			CK73HB1C103K	CHIP C 0.01UF K		
C429			CK73HB1E471K	CHIP C 470PF K		
C430			CK73GR1C473K	CHIP C 0.047UF K		
C431			CK73HB1E471K	CHIP C 470PF K		
C432		*	C92-0617-05	ELECTRO 220UF 4WV		
C433, 434			C92-0576-05	TANTAL 1UF 6.3WV		
C435, 436			CK73HB1E471K	CHIP C 470PF K		
C437, 438			CK73GR1C473K	CHIP C 0.047UF K		
C439			CK73HB1C103K	CHIP C 0.01UF K		
C441			C90-2108-05	ELECTRO 2.2UF 16WV		
TC1			C05-0380-05	TRIMMER CAPACITOR 10PF		
A4	3A, 2C	*	E37-0425-15	FLAT CABLE (26P:RF-CONT UNIT)		
CN1		*	E40-5641-05	FLAT CABLE CONNECTOR(26P)		
CN2		*	E40-5666-05	PIN ASSY SOCKET		
CN3		*	E40-5667-05	PIN ASSY		
CN4			E23-0486-05	TERMINAL		
CN5 ,6		*	E23-0965-14	TERMINAL (BATT)		
CN301			E40-5180-05	PIN ASSY (3P)		
CN302		*	E40-5641-05	FLAT CABLE CONNECTOR(26P)		
CN303			E40-5618-05	FLAT CABLE CONNECTOR(8P)		
CN304			E40-5629-05	PIN ASSY (6P)		
CN305			E40-5630-05	PIN ASSY SOCKET(6P)		
CN306		*	E40-5656-05	PIN ASSY SOCKET(22P)		
CN307		*	E40-5655-05	PIN ASSY (22P)		
CN309			E23-0486-05	TERMINAL		
J2			E03-0170-05	DC JACK		
J301			E11-0457-05	PHONE JACK		
W301			E33-1885-05	FINISHED WIRE SET	KPBTM	
A2		*	F10-2135-14	SHIELDING PLATE(UHF VCO)		
A303, 304		*	F20-1154-04	INSULATING SHEET(ENC,VOL)		
A1		*	G02-0759-04	EARTH SPRING (RF)		
A3		*	G13-1465-04	CUSHION (12.8MHZ X, TAL)		
A5			G11-0682-04	SEAL (VHF VCO)		
A6		*	G11-0732-04	SHEET (IC312)		
A302		*	G02-0762-14	EARTH SPRING (G/7 PCB)		
A305		*	J30-1201-04	SPACER(CPU)		
CD1		*	L79-1113-05	FILTER(450KHZ)		
CD2			L79-1013-05	FILTER(455KHZ)		
CF1		*	L72-0902-05	CERAMIC FILTER(450KHZ)		
CF2			L72-0362-05	CERAMIC FILTER(455KHZ)		
L1 ,2			L92-0137-05	CORE		
L3 -10			L92-0138-05	CORE		
L11			L40-1095-34	SMALL FIXED INDUCTOR(1UH)		
L12			L40-1281-34	SMALL FIXED INDUCTOR(120NH)		
L13		*	L40-5681-42	SMALL FIXED INDUCTOR(0.56UH)		
L14		*	L40-1091-37	SMALL FIXED INDUCTOR(1UH)		
L15		*	L40-5681-42	SMALL FIXED INDUCTOR(0.56UH)		
L16			L40-1871-36	SMALL FIXED INDUCTOR(18NH)		
L17		*	L40-1271-36	SMALL FIXED INDUCTOR(12NH)		
L18			L40-1871-36	SMALL FIXED INDUCTOR(18NH)		
L19		*	L34-4360-05	COIL		

PARTS LIST

× New Parts

Parts without Parts No. are not supplied.

Les articles non mentionnes dans le Parts No. ne sont pas fournis.

Teile ohne Parts No. werden nicht geliefert.

TX-RX UNIT(X57-440X-XX)

Ref. No. 参照番号	Address 位置	New Parts 新	Parts No. 部品番号	Description 部品名 / 規格	Desti- nation 仕 向	Re- marks 備考
L20		*	L79-1108-05	HELICAL BLOCK(435MHZ)	XTMM2	
L20		*	L79-1108-05	HELICAL BLOCK(435MHZ)	M3M4E	
L20		*	L79-1108-05	HELICAL BLOCK(435MHZ)	E2E3E9	
L20		*	L79-1109-05	HELICAL BLOCK(444MHZ)	KP	
L21			L40-8271-35	SMALL FIXED INDUCTOR(82NH)		
L22			L40-1871-36	SMALL FIXED INDUCTOR(18NH)		
L23			L40-3985-34	SMALL FIXED INDUCTOR(390NH)		
L24		*	L40-1271-35	SMALL FIXED INDUCTOR(12NH)		
L25			L40-2271-36	SMALL FIXED INDUCTOR(22NH)		
L26			L40-6861-36	SMALL FIXED INDUCTOR(6.8NH)	XTMM2	
L26			L40-6861-36	SMALL FIXED INDUCTOR(6.8NH)	M3M4E	
L26			L40-6861-36	SMALL FIXED INDUCTOR(6.8NH)	E2E3E9	
L27			L34-1373-05	COIL (2.5T)		
L28 ,29			L40-1871-36	SMALL FIXED INDUCTOR(18NH)		
L30			L40-2271-36	SMALL FIXED INDUCTOR(22NH)		
L31			L40-1871-36	SMALL FIXED INDUCTOR(18NH)		
L32			L40-1085-34	SMALL FIXED INDUCTOR(100NH)		
L33			L40-5671-34	SMALL FIXED INDUCTOR(56NH)		
L34			L40-1271-34	SMALL FIXED INDUCTOR(12NH)	KP	
L34			L40-1571-34	SMALL FIXED INDUCTOR(15NH)	XTMM2	
L34			L40-1571-34	SMALL FIXED INDUCTOR(15NH)	M3M4E	
L34			L40-1571-34	SMALL FIXED INDUCTOR(15NH)	E2E3E9	
L35		*	L40-2771-40	SMALL FIXED INDUCTOR(27NH)		
L36		*	L34-4359-05	COIL		
L37		*	L40-2771-40	SMALL FIXED INDUCTOR(27NH)		
L38			L92-0138-05	CORE		
L39		*	L40-3961-38	SMALL FIXED INDUCTOR(3.9NH)	XTMM2	
L39		*	L40-3961-38	SMALL FIXED INDUCTOR(3.9NH)	M3M4E	
L39		*	L40-3961-38	SMALL FIXED INDUCTOR(3.9NH)	E2E3E9	
L40			L92-0138-05	CORE		
L41			L40-4761-36	SMALL FIXED INDUCTOR(4.7NH)	XTMM2	
L41			L40-4761-36	SMALL FIXED INDUCTOR(4.7NH)	M3M4E	
L41			L40-4761-36	SMALL FIXED INDUCTOR(4.7NH)	E2E3E9	
L42			L40-5671-34	SMALL FIXED INDUCTOR(56NH)		
L43			L40-2771-36	SMALL FIXED INDUCTOR(27NH)		
L44			L40-6871-35	SMALL FIXED INDUCTOR(68NH)		
L45			L40-1271-34	SMALL FIXED INDUCTOR(12NH)	KP	
L45			L40-1571-34	SMALL FIXED INDUCTOR(15NH)	XTMM2	
L45			L40-1571-34	SMALL FIXED INDUCTOR(15NH)	M3M4E	
L45			L40-1571-34	SMALL FIXED INDUCTOR(15NH)	E2E3E9	
L46			L40-1095-34	SMALL FIXED INDUCTOR(10H)		
L47			L40-1085-34	SMALL FIXED INDUCTOR(100NH)		
L48			L40-1871-36	SMALL FIXED INDUCTOR(18NH)		
L50			L40-2271-36	SMALL FIXED INDUCTOR(22NH)		
L51			L34-1264-05	COIL (2.5T)		
L52			L40-2271-36	SMALL FIXED INDUCTOR(22NH)		
L53			L40-6871-34	SMALL FIXED INDUCTOR(68NH)		
L54			L40-1095-34	SMALL FIXED INDUCTOR(10H)		
L55			L40-3371-36	SMALL FIXED INDUCTOR(3.3NH)		
L56			L40-2785-34	SMALL FIXED INDUCTOR(270NH)		
L57 ,58			L34-1264-05	COIL (2.5T)		
L59			L40-1085-34	SMALL FIXED INDUCTOR(100NH)		
L60		*	L79-1101-05	FILTER(146/440MHZ)		
L61		*	L40-3961-38	SMALL FIXED INDUCTOR(3.9NH)	XTMM2	
L61		*	L40-3961-38	SMALL FIXED INDUCTOR(3.9NH)	M3M4E	

TH-79 A/E

PARTS LIST

× New Parts

Parts without Parts No. are not supplied.

Les articles non mentionnés dans le Parts No. ne sont pas fournis.

Teile ohne Parts No. werden nicht geliefert.

TX-RX UNIT(X57-440X-XX)

Ref. No. 参照番号	Address 位置	New Parts 新	Parts No. 部品番号	Description 部品名 / 規格	Desti- nation 仕向	Re- marks 備考
L61		*	L40-3961-38	SMALL FIXED INDUCTOR(3.9NH)	E2E3E9	
L62			L40-1092-81	SMALL FIXED INDUCTOR		
L63			L34-1333-05	COIL (8.5T)		
L64			L34-1327-05	COIL (7.5T)		
L65			L40-2271-35	SMALL FIXED INDUCTOR(22NH)		
L66			L40-1871-36	SMALL FIXED INDUCTOR(18NH)		
L67			L92-0138-05	CORE		
L68 ,69		*	L40-1071-35	SMALL FIXED INDUCTOR(10NH)	XTMM2	
L68 ,69		*	L40-1071-35	SMALL FIXED INDUCTOR(10NH)	M3M4E	
L68 ,69		*	L40-1071-35	SMALL FIXED INDUCTOR(10NH)	E2E3E9	
L301-309			L92-0138-05	CORE		
L310			L33-0737-05	CHOKER COIL		
L312-316			L92-0138-05	CORE		
L319,320			L92-0138-05	CORE		
L321,322			L92-0131-05	CORE		
X1			L77-1438-15	CRYSTAL RESONATOR(45.505MHZ)		
X2			L77-1528-05	CRYSTAL RESONATOR(12.8MHZ)		
X301			L78-0326-05	RESONATOR (4.19MHZ)		
XF1		*	L71-0439-05	MCF (38.850MHZ)		
XF2			L71-0409-15	MCF (45.05MHZ)		
CP301,302			R90-0724-05	MULTI COMP		
CP303			R90-0718-05	MULTI COMP 4.7X4		
CP304			R90-0719-05	MULTI COMP		
CP305			R90-0718-05	MULTI COMP 4.7X4		
R1			RK73FB2A120J	CHIP R 12 J 1/10W		
R2 -4			RK73GB1J102J	CHIP R 1.0K J 1/16W		
R5			RK73GB1J103J	CHIP R 10K J 1/16W		
R6			RK73HB1J103J	CHIP R 10K J 1/16W		
R7		*	RK73HB1J152J	CHIP R 1.5K J 1/16W		
R8			RK73HB1J473J	CHIP R 47K J 1/16W		
R9			RK73HB1J222J	CHIP R 2.2K J 1/16W		
R10		*	RK73HB1J272J	CHIP R 2.7K J 1/16W		
R11			RK73HB1J472J	CHIP R 4.7K J 1/16W		
R12			RK73GB1J102J	CHIP R 1.0K J 1/16W		
R13 ,14			RK73HB1J103J	CHIP R 10K J 1/16W		
R15			RK73HB1J470J	CHIP R 47 J 1/16W		
R16			RK73HB1J334J	CHIP R 330K J 1/16W		
R17 ,18			RK73HB1J103J	CHIP R 10K J 1/16W		
R19			RK73HB1J222J	CHIP R 2.2K J 1/16W		
R20			RK73HB1J102J	CHIP R 1.0K J 1/16W		
R21			RK73HB1J472J	CHIP R 4.7K J 1/16W		
R22			RK73HB1J104J	CHIP R 100K J 1/16W		
R23			RK73HB1J182J	CHIP R 1.8K J 1/16W		
R24			RK73HB1J562J	CHIP R 5.6K J 1/16W		
R25 ,26			RK73HB1J103J	CHIP R 10K J 1/16W		
R27			RK73HB1J823J	CHIP R 82K J 1/16W		
R28		*	RK73HB1J152J	CHIP R 1.5K J 1/16W		
R29			RK73HB1J154J	CHIP R 150K J 1/16W		
R30			RK73HB1J681J	CHIP R 680 J 1/16W		
R31		*	RK73HB1J152J	CHIP R 1.5K J 1/16W		
R32			RK73HB1J154J	CHIP R 150K J 1/16W		
R33 -35			RK73HB1J103J	CHIP R 10K J 1/16W		
R36			RK73HB1J473J	CHIP R 47K J 1/16W		
R37			RK73HB1J472J	CHIP R 4.7K J 1/16W		
R38			RK73HB1J334J	CHIP R 330K J 1/16W		

TH-79 A/E

PARTS LIST

× New Parts

Parts without Parts No. are not supplied.

Les articles non mentionnés dans le Parts No. ne sont pas fournis.

Teile ohne Parts No. werden nicht geliefert.

TX-RX UNIT(X57-440X-XX)

Ref. No. 参照番号	Address 位置	New Parts 新	Parts No. 部品番号	Description 部品名 / 規格	Desti- nation 仕向	Re- marks 備考
R39			RK73HB1J472J	CHIP R 4.7K J 1/16W		
R40			RK73HB1J334J	CHIP R 330K J 1/16W		
R41			RK73HB1J122J	CHIP R 1.2K J 1/16W		
R42			RK73HB1J221J	CHIP R 220 J 1/16W		
R43			RK73HB1J274J	CHIP R 270K J 1/16W		
R44			RK73HB1J561J	CHIP R 560 J 1/16W		
R45			RK73HB1J274J	CHIP R 270K J 1/16W		
R46 ,47			RK73HB1J561J	CHIP R 560 J 1/16W		
R48 ,49		*	RK73HB1J152J	CHIP R 1.5K J 1/16W		
R50			RK73HB1J332J	CHIP R 3.3K J 1/16W		
R51			RK73GB1J332J	CHIP R 3.3K J 1/16W		
R52 ,53			RK73HB1J470J	CHIP R 47 J 1/16W		
R54			RK73HB1J472J	CHIP R 4.7K J 1/16W		
R55			RK73GB1J472J	CHIP R 4.7K J 1/16W		
R56			RK73HB1J102J	CHIP R 1.0K J 1/16W		
R57			RK73HB1J472J	CHIP R 4.7K J 1/16W		
R58			RK73HB1J102J	CHIP R 1.0K J 1/16W		
R59			RK73HB1J103J	CHIP R 10K J 1/16W		
R60			RK73HB1J472J	CHIP R 4.7K J 1/16W		
R61			RK73HB1J103J	CHIP R 10K J 1/16W		
R62			RK73HB1J101J	CHIP R 100 J 1/16W		
R63			RK73HB1J472J	CHIP R 4.7K J 1/16W		
R64			RK73HB1J183J	CHIP R 18K J 1/16W		
R64			RK73HB1J183J	CHIP R 18K J 1/16W		
R65			RK73HB1J122J	CHIP R 1.2K J 1/16W		KPXM2 M3M4
R66 ,67		*	RK73HB1J564J	CHIP R 560K J 1/16W		
R68			RK73HB1J223J	CHIP R 22K J 1/16W		
R69			RK73HB1J103J	CHIP R 10K J 1/16W		
R70			RK73HB1J473J	CHIP R 47K J 1/16W		
R71		*	RK73HB1J152J	CHIP R 1.5K J 1/16W		
R72			RK73HB1J101J	CHIP R 100 J 1/16W		
R73			RK73HB1J473J	CHIP R 47K J 1/16W		
R74		*	RK73HB1J272J	CHIP R 2.7K J 1/16W		
R75			RK73HB1J392J	CHIP R 3.9K J 1/16W		
R76 ,77		*	RK73HB1J272J	CHIP R 2.7K J 1/16W		
R78			RK73HB1J101J	CHIP R 100 J 1/16W		
R79			RK73HB1J681J	CHIP R 680 J 1/16W		
R80 -82			RK73HB1J392J	CHIP R 3.9K J 1/16W		
R83		*	RK73HB1J272J	CHIP R 2.7K J 1/16W		
R84			RK73HB1J683J	CHIP R 68K J 1/16W		
R85 ,86			RK73HB1J392J	CHIP R 3.9K J 1/16W		
R87			RK73HB1J104J	CHIP R 100K J 1/16W		
R88			RK73HB1J103J	CHIP R 10K J 1/16W		
R89			RK73HB1J104J	CHIP R 100K J 1/16W		
R90			RK73HB1J105J	CHIP R 1M J 1/16W		
R91			RK73HB1J473J	CHIP R 47K J 1/16W		
R92			RK73HB1J273J	CHIP R 27K J 1/16W		
R93			RK73GB1J561J	CHIP R 560 J 1/16W		
R94			RK73HB1J680J	CHIP R 68 J 1/16W		
R95 -97			RK73HB1J103J	CHIP R 10K J 1/16W		
R98		*	RK73HB1J152J	CHIP R 1.5K J 1/16W		
R99			RK73HB1J332J	CHIP R 3.3K J 1/16W		
R100			RK73HB1J151J	CHIP R 150 J 1/16W		
R101			RK73HB1J223J	CHIP R 22K J 1/16W		
R102			RK73HB1J154J	CHIP R 150K J 1/16W		

PARTS LIST

× New Parts

Parts without Parts No. are not supplied.

Les articles non mentionnés dans le Parts No. ne sont pas fournis.

Teile ohne Parts No. werden nicht geliefert.

TX-RX UNIT(X57-440X-XX)

Ref. No. 参照番号	Address 位置	New Parts 新	Parts No. 部品番号	Description 部品名 / 規格	Desti- nation 仕向	Re- marks 備考
R103			RK73HB1J274J	CHIP R 270K J 1/16W		
R104			RK73HB1J561J	CHIP R 560 J 1/16W		
R105			RK73HB1J332J	CHIP R 3.3K J 1/16W		
R106			RK73HB1J561J	CHIP R 560 J 1/16W		
R107			RK73HB1J472J	CHIP R 4.7K J 1/16W		
R108			RK73HB1J561J	CHIP R 560 J 1/16W		
R109			RK73HB1J392J	CHIP R 3.9K J 1/16W		
R110			RK73HB1J822J	CHIP R 8.2K J 1/16W		
R111			RK73HB1J222J	CHIP R 2.2K J 1/16W		
R112			RK73HB1J680J	CHIP R 68 J 1/16W		
R113			RK73HB1J472J	CHIP R 4.7K J 1/16W		
R114			RK73HB1J123J	CHIP R 12K J 1/16W		
R115		*	RK73HB1J272J	CHIP R 2.7K J 1/16W		
R116			RK73HB1J392J	CHIP R 3.9K J 1/16W		
R117			RK73HB1J220J	CHIP R 22 J 1/16W		
R118			RK73HB1J680J	CHIP R 68 J 1/16W		
R119			RK73HB1J471J	CHIP R 470 J 1/16W		
R120			RK73HB1J104J	CHIP R 100K J 1/16W		
R121			RK73HB1J220J	CHIP R 22 J 1/16W		
R122			RK73HB1J472J	CHIP R 4.7K J 1/16W		
R123			RK73HB1J561J	CHIP R 560 J 1/16W		
R124			RK73HB1J104J	CHIP R 100K J 1/16W		
R125		*	RK73HB1J272J	CHIP R 2.7K J 1/16W	XTMM2	
R125		*	RK73HB1J272J	CHIP R 2.7K J 1/16W	M3M4E	
R125		*	RK73HB1J272J	CHIP R 2.7K J 1/16W	E2E3E9	
R126			RK73HB1J151J	CHIP R 150 J 1/16W		
R127			RK73HB1J182J	CHIP R 1.8K J 1/16W		
R128			RK73HB1J680J	CHIP R 68 J 1/16W		
R129			RK73HB1J102J	CHIP R 1.0K J 1/16W		
R130			RK73HB1J391J	CHIP R 390 J 1/16W		
R131		*	RK73HB1J272J	CHIP R 2.7K J 1/16W		
R132			RK73HB1J680J	CHIP R 68 J 1/16W		
R133		*	RK73HB1J272J	CHIP R 2.7K J 1/16W		
R134, 135			RK73HB1J101J	CHIP R 100 J 1/16W	XTMM2	
R134, 135			RK73HB1J101J	CHIP R 100 J 1/16W	M3M4E	
R134, 135			RK73HB1J101J	CHIP R 100 J 1/16W	E2E3E9	
R135			RK73HB1J101J	CHIP R 100 J 1/16W	KP	
R136			RK73HB1J220J	CHIP R 22 J 1/16W		
R137			RK73HB1J270J	CHIP R 27 J 1/16W		
R138			RK73HB1J391J	CHIP R 390 J 1/16W		
R139			RK73HB1J102J	CHIP R 1.0K J 1/16W		
R140			RK73HB1J270J	CHIP R 27 J 1/16W		
R141			RK73HB1J392J	CHIP R 3.9K J 1/16W		
R142			RK73HB1J561J	CHIP R 560 J 1/16W		
R143, 144			RK73HB1J180J	CHIP R 18 J 1/16W		
R145			RK73HB1J103J	CHIP R 10K J 1/16W		
R146, 147			RK73HB1J561J	CHIP R 560 J 1/16W		
R148			RK73HB1J104J	CHIP R 100K J 1/16W		
R149			RK73HB1J681J	CHIP R 680 J 1/16W	XTMM2	
R149			RK73HB1J681J	CHIP R 680 J 1/16W	M3M4E	
R149			RK73HB1J681J	CHIP R 680 J 1/16W	E2E3E9	
R150			RK73HB1J470J	CHIP R 47 J 1/16W		
R151			RK73HB1J391J	CHIP R 390 J 1/16W		
R154			RK73HB1J332J	CHIP R 3.3K J 1/16W	XTMM2	
R154			RK73HB1J332J	CHIP R 3.3K J 1/16W	M3M4E	

TH-79 A/E

PARTS LIST

× New Parts

Parts without Parts No. are not supplied.

Les articles non mentionnés dans le Parts No. ne sont pas fournis.

Teile ohne Parts No. werden nicht geliefert.

TX-RX UNIT(X57-440X-XX)

Ref. No. 参照番号	Address 位置	New Parts 新	Parts No. 部品番号	Description 部品名 / 規格	Desti- nation 仕向	Re- marks 備考
R154			RK73HB1J332J	CHIP R 3.3K J 1/16W	E2E3E9	
R155			RK73HB1J222J	CHIP R 2.2K J 1/16W		
R156, 157			RK73HB1J100J	CHIP R 10 J 1/16W		
R158			RK73HB1J332J	CHIP R 3.3K J 1/16W		
R160			RK73HB1J472J	CHIP R 4.7K J 1/16W	XTMM2	
R160			RK73HB1J472J	CHIP R 4.7K J 1/16W	M3M4E	
R160			RK73HB1J472J	CHIP R 4.7K J 1/16W	E2E3E9	
R162			RK73HB1J221J	CHIP R 220 J 1/16W		
R163			RK73HB1J472J	CHIP R 4.7K J 1/16W		
R164			RK73HB1J820J	CHIP R 82 J 1/16W	XTMM2	
R164			RK73HB1J820J	CHIP R 82 J 1/16W	M3M4E	
R164			RK73HB1J820J	CHIP R 82 J 1/16W	E2E3E9	
R165			RK73HB1J270J	CHIP R 27 J 1/16W		
R166			RK73HB1J224J	CHIP R 220K J 1/16W		
R167		*	RK73HB1J124J	CHIP R 120K J 1/16W		
R168			RK73HB1J102J	CHIP R 1.0K J 1/16W		
R169			RK73HB1J392J	CHIP R 3.9K J 1/16W	XTMM2	
R169			RK73HB1J392J	CHIP R 3.9K J 1/16W	M3M4E	
R169			RK73HB1J392J	CHIP R 3.9K J 1/16W	E2E3E9	
R170			RK73HB1J561J	CHIP R 560 J 1/16W		
R171			RK73GB1J680J	CHIP R 68 J 1/16W		
R172			RK73HB1J270J	CHIP R 27 J 1/16W		
R173			RK73HB1J392J	CHIP R 3.9K J 1/16W		
R174			RK73HB1J101J	CHIP R 100 J 1/16W		
R175			RK73HB1J683J	CHIP R 68K J 1/16W	XTMM2	
R175			RK73HB1J683J	CHIP R 68K J 1/16W	M3M4E	
R175			RK73HB1J683J	CHIP R 68K J 1/16W	E2E3E9	
R176, 177			RK73HB1J101J	CHIP R 100 J 1/16W		
R179		*	RK73HB1J152J	CHIP R 1.5K J 1/16W		
R180			RK73GB1J680J	CHIP R 68 J 1/16W		
R182			RK73HB1J222J	CHIP R 2.2K J 1/16W		
R183			RK73HB1J473J	CHIP R 47K J 1/16W		
R184		*	RK73HB1J124J	CHIP R 120K J 1/16W		
R185			RK73HB1J222J	CHIP R 2.2K J 1/16W		
R186			RK73HB1J121J	CHIP R 120 J 1/16W		
R187			RK73HB1J332J	CHIP R 3.3K J 1/16W		
R188			RK73HB1J391J	CHIP R 390 J 1/16W	XTMM2	
R188			RK73HB1J391J	CHIP R 390 J 1/16W	M3M4E	
R188			RK73HB1J391J	CHIP R 390 J 1/16W	E2E3E9	
R189			RK73HB1J182J	CHIP R 1.8K J 1/16W	XTMM2	
R189			RK73HB1J182J	CHIP R 1.8K J 1/16W	M3M4E	
R189			RK73HB1J182J	CHIP R 1.8K J 1/16W	E2E3E9	
R190, 191			RK73HB1J220J	CHIP R 22 J 1/16W		
R192			RK73HB1J102J	CHIP R 1.0K J 1/16W		
R193			R92-1368-05	CHIP R 0 OHM 1/16W		
R194			R92-0670-05	CHIP R 0 OHM	KP	
R195			RK73HB1J473J	CHIP R 47K J 1/16W		
R196			RK73HB1J103J	CHIP R 10K J 1/16W		
R198			RK73HB1J221J	CHIP R 220 J 1/16W		
R200			RK73HB1J223J	CHIP R 22K J 1/16W		
R301			RK73HB1J101J	CHIP R 100 J 1/16W		
R302, 303			RK73HB1J104J	CHIP R 100K J 1/16W		
R304			RK73GB1J103J	CHIP R 10K J 1/16W		
R305			RK73HB1J222J	CHIP R 2.2K J 1/16W		
R306			RK73HB1J102J	CHIP R 1.0K J 1/16W		

PARTS LIST

※ New Parts

Parts without Parts No. are not supplied.

Les articles non mentionnés dans le Parts No. ne sont pas fournis.

Teile ohne Parts No. werden nicht geliefert.

TX-RX UNIT(X57-440X-XX)

Ref. No. 参照番号	Address 位置	New Parts 新	Parts No. 部品番号	Description 部品名 / 規格	Desti- nation 仕向	Re- marks 備考
R307			RK73HB1J682J	CHIP R 6.8K J 1/16W		
R308		*	R92-2539-05	CHIP R 330K 1/16W		
R309		*	RN73HH1J683D	CHIP R 68K D 1/16W		
R310, 311			RK73HB1J100J	CHIP R 10 J 1/16W		
R312			RK73HB1J101J	CHIP R 100 J 1/16W		
R313			RK73HB1J221J	CHIP R 220 J 1/16W		
R315			RK73HB1J122J	CHIP R 1.2K J 1/16W		
R316			RK73GB1J272J	CHIP R 2.7K J 1/16W		
R317			RK73HB1J182J	CHIP R 1.8K J 1/16W		
R318			RK73HB1J563J	CHIP R 56K J 1/16W		
R319			RK73HB1J153J	CHIP R 15K J 1/16W	KPXMM2	
R319			RK73HB1J153J	CHIP R 15K J 1/16W	M3M4	
R320			RK73HB1J561J	CHIP R 560 J 1/16W		
R321			RK73GB1J563J	CHIP R 56K J 1/16W		
R322, 323			RK73HB1J103J	CHIP R 10K J 1/16W		
R324			RK73GB1J273J	CHIP R 27K J 1/16W		
R325			RK73HB1J472J	CHIP R 4.7K J 1/16W		
R326-328			RK73GB1J472J	CHIP R 4.7K J 1/16W		
R329			RK73HB1J103J	CHIP R 10K J 1/16W		
R330			RK73GB1J391J	CHIP R 390 J 1/16W		
R331			RK73GB1J104J	CHIP R 100K J 1/16W		
R332			RK73HB1J472J	CHIP R 4.7K J 1/16W		
R334, 335			RK73HB1J104J	CHIP R 100K J 1/16W		
R336			RK73HB1J472J	CHIP R 4.7K J 1/16W		
R337			RK73HB1J102J	CHIP R 1.0K J 1/16W		
R339			RK73HB1J472J	CHIP R 4.7K J 1/16W		
R340			RK73HB1J334J	CHIP R 330K J 1/16W		
R341			RK73GB1J682J	CHIP R 6.8K J 1/16W		
R342			RK73GB1J223J	CHIP R 22K J 1/16W		
R343			RK73GB1J103J	CHIP R 10K J 1/16W		
R344			RK73HB1J472J	CHIP R 4.7K J 1/16W		
R345			RK73HB1J103J	CHIP R 10K J 1/16W		
R347, 348			RK73GB1J473J	CHIP R 47K J 1/16W		
R349			RK73HB1J104J	CHIP R 100K J 1/16W		
R351, 352			RK73GB1J473J	CHIP R 47K J 1/16W		
R353			RK73HB1J273J	CHIP R 27K J 1/16W		
R354			RK73HB1J100J	CHIP R 10 J 1/16W		
R355			RK73HB1J472J	CHIP R 4.7K J 1/16W		
R360			RK73HB1J104J	CHIP R 100K J 1/16W		
R366			RK73GB1J472J	CHIP R 4.7K J 1/16W		
R368		*	R92-2539-05	CHIP R 330K 1/16W		
R369			RK73HB1J100J	CHIP R 10 J 1/16W		
R370			RK73GB1J913J	CHIP R 91K J 1/16W		
R371		*	RK73HB1J272J	CHIP R 2.7K J 1/16W		
R372			RK73HB1J222J	CHIP R 2.2K J 1/16W		
R373			RK73HB1J332J	CHIP R 3.3K J 1/16W		
R374			RK73HB1J102J	CHIP R 1.0K J 1/16W		
R375			RK73HB1J224J	CHIP R 220K J 1/16W		
R376			RK73HB1J472J	CHIP R 4.7K J 1/16W		
R377			RK73HB1J222J	CHIP R 2.2K J 1/16W		
R378			RK73HB1J122J	CHIP R 1.2K J 1/16W		
R379			RK73HB1J182J	CHIP R 1.8K J 1/16W		
R380			RK73GB1J102J	CHIP R 1.0K J 1/16W		
R381, 382			RK73HB1J683J	CHIP R 68K J 1/16W		
R383			RK73HB1J472J	CHIP R 4.7K J 1/16W		

TH-79 A/E

PARTS LIST

× New Parts

Parts without Parts No. are not supplied.

Les articles non mentionnés dans le Parts No. ne sont pas fournis.

Teile ohne Parts No. werden nicht geliefert.

TX-RX UNIT(X57-440X-XX)

Ref. No. 参照番号	Address 位置	New Parts 新	Parts No. 部品番号	Description 部品名 / 規格	Desti- nation 仕 向	Re- marks 備考
R384			RK73HB1J332J	CHIP R 3.3K J 1/16W		
R385			RK73HB1J102J	CHIP R 1.0K J 1/16W		
R386		*	RK73HB1J272J	CHIP R 2.7K J 1/16W		
R387, 388			RK73HB1J222J	CHIP R 2.2K J 1/16W		
R389			RK73HB1J472J	CHIP R 4.7K J 1/16W		
R390, 391			RK73HB1J221J	CHIP R 220 J 1/16W		
R392, 393			RK73HB1J154J	CHIP R 150K J 1/16W		
R394			RK73HB1J102J	CHIP R 1.0K J 1/16W		
R395			RK73GB1J473J	CHIP R 47K J 1/16W		
R396			RK73HB1J222J	CHIP R 2.2K J 1/16W		
R397		*	RK73HB1J272J	CHIP R 2.7K J 1/16W		
R398			RK73HB1J473J	CHIP R 47K J 1/16W		
R399			RK73HB1J102J	CHIP R 1.0K J 1/16W		
R400			RK73HB1J222J	CHIP R 2.2K J 1/16W		
R401		*	RK73HB1J272J	CHIP R 2.7K J 1/16W		
R402			RK73HB1J100J	CHIP R 10 J 1/16W		
R403			R92-0679-05	CHIP R 0 0HM		XTMM2
R403			R92-0679-05	CHIP R 0 0HM		M2M3E
R403			R92-0679-05	CHIP R 0 0HM		E2E3E9
R404			RK73GB1J104J	CHIP R 100K J 1/16W		
R405			RK73HB1J332J	CHIP R 3.3K J 1/16W		
R406			RK73HB1J104J	CHIP R 100K J 1/16W		
R407			RK73GB1J104J	CHIP R 100K J 1/16W		
R408			RK73HB1J100J	CHIP R 10 J 1/16W		
R409			RK73GB1J104J	CHIP R 100K J 1/16W		
R410, 411			RK73GB1J680J	CHIP R 68 J 1/16W		
R413			RK73GB1J104J	CHIP R 100K J 1/16W		
R414			RK73HB1J103J	CHIP R 10K J 1/16W		
R415			RK73GB1J474J	CHIP R 470K J 1/16W		
R416, 417			RK73GB1J104J	CHIP R 100K J 1/16W		
R418			RK73FB2A2R2J	CHIP R 2.2 J 1/10W		
R419			RK73HB1J182J	CHIP R 1.8K J 1/16W		
R420			RK73GB1J820J	CHIP R 82 J 1/16W		
R421			RK73GB1J680J	CHIP R 68 J 1/16W		
R423			RK73HB1J182J	CHIP R 1.8K J 1/16W		
R424, 425			RK73HB1J100J	CHIP R 10 J 1/16W		
R426			RK73HB1J682J	CHIP R 6.8K J 1/16W		
R427			RK73GB1J273J	CHIP R 27K J 1/16W		
R428			RK73GB1J102J	CHIP R 1.0K J 1/16W		
R429			RK73HB1J222J	CHIP R 2.2K J 1/16W		
R430			RK73HB1J472J	CHIP R 4.7K J 1/16W		
R431			RK73HB1J103J	CHIP R 10K J 1/16W		
R432			RK73HB1J472J	CHIP R 4.7K J 1/16W		
R433			RK73HB1J274J	CHIP R 270K J 1/16W		
R434-436			RK73EB2ER39K	CHIP R 0.39 K 1/4W		
R437			RK73GB1J562J	CHIP R 5.6K J 1/16W		
R438			RK73GB1J103J	CHIP R 10K J 1/16W		
R439			RK73GB1J473J	CHIP R 47K J 1/16W		
R440			RK73HB1J123J	CHIP R 12K J 1/16W		
R441			RK73HB1J471J	CHIP R 470 J 1/16W		
R442-445			RK73GB1J121J	CHIP R 120 J 1/16W		
R446			RK73HB1J182J	CHIP R 1.8K J 1/16W		
R447			RK73FB2A101J	CHIP R 100 J 1/10W		
R448			RK73HB1J101J	CHIP R 100 J 1/16W		
R449			RK73GB1J472J	CHIP R 4.7K J 1/16W		

TH-79 A/E

PARTS LIST

× New Parts

Parts without Parts No. are not supplied.

Les articles non mentionnes dans le Parts No. ne sont pas fournis.

Teile ohne Parts No. werden nicht geliefert.

TX-RX UNIT(X57-440X-XX)

Ref. No. 参照番号	Address 位置	New Parts 新	Parts No. 部品番号	Description 部品名 / 規格	Desti- nation 仕 向	Re- marks 備考
R450-453			RK73HB1J104J	CHIP R 100K J 1/16W		
R454-458			RK73HB1J472J	CHIP R 4.7K J 1/16W		
R459-464			RK73HB1J222J	CHIP R 2.2K J 1/16W		
R465-467			RK73HB1J104J	CHIP R 100K J 1/16W		
R470			RK73HB1J100J	CHIP R 10 J 1/16W		
R471			RK73HB1J222J	CHIP R 2.2K J 1/16W		
R501,502			RK73GB1J222J	CHIP R 2.2K J 1/16W		
R503-505			RK73HB1J104J	CHIP R 100K J 1/16W		
R506,507			RK73HB1J333J	CHIP R 33K J 1/16W		
R508			RK73GB1J103J	CHIP R 10K J 1/16W		
R509			RK73GB1J223J	CHIP R 22K J 1/16W		
R511			RK73GB1J474J	CHIP R 470K J 1/16W		
R512			RK73GB1J104J	CHIP R 100K J 1/16W		
R513			RK73HB1J223J	CHIP R 22K J 1/16W		
R514,515			RK73HB1J100J	CHIP R 10 J 1/16W		
R516			RK73GB1J563J	CHIP R 56K J 1/16W		
R517,518			RK73HB1J103J	CHIP R 10K J 1/16W		
R519-522			RK73HB1J222J	CHIP R 2.2K J 1/16W		
R524			RK73HB1J222J	CHIP R 2.2K J 1/16W		
R525			RK73GB1J474J	CHIP R 470K J 1/16W		
R526,527			RK73GB1J102J	CHIP R 1.0K J 1/16W		
R528-533			RK73HB1J104J	CHIP R 100K J 1/16W		
R534			RK73FB2A683J	CHIP R 68K J 1/16W		
VR301,302			R12-6717-05	TRIM POT 47K		
VR303			R12-6713-05	TRIMMING POT. 10K		
VR304,305			R12-6705-05	TRIM POT 470		
VR306,307		*	R12-6701-05	TRIMMING POT. 100		
VR308			R05-3469-05	POTENTIOMETER 10K(AF VOL A/PS)		
VR309		*	R39-0601-05	POTENTIOMETER 10K(AF VOL B/ENC)		
S303			S40-1117-05	TACT SWITCH		
S304			S62-0421-05	SLIDE SWITCH		
S305,306		*	S70-0438-05	TACT SWITCH		
D1			DA221	DIØRD		
D2			SFPB-72VL	DIØRD		
D3 ,4			MA742	DIØRD		
D5 -8			MA2S111	DIØRD		
D9 -12			MA77	DIØRD		
D13			MA368	DIØRD		
D15			DA204U	DIØRD		
D16			MA77	DIØRD		XTMM2
D16			MA77	DIØRD		M3M4E
D16			MA77	DIØRD		E2E3E9
D17			DAN222	DIØRD		
D18			MA368	DIØRD		
D19			MA77	DIØRD		
D20			HZU2.0	DIØRD		
D21			MA77	DIØRD		
D22			MA368	DIØRD		
D23 -25			MA77	DIØRD		
D26 ,27			M1809	DIØRD		
D28 -30			MA77	DIØRD		
D31			1SS312	DIØRD		
D32			DAN222	DIØRD		
D33 ,34			DA221	DIØRD		

TH-79 A/E

PARTS LIST

× New Parts

Parts without Parts No. are not supplied.

Les articles non mentionnés dans le Parts No. ne sont pas fournis.

Teile ohne Parts No. werden nicht geliefert.

TX-RX UNIT(X57-440X-XX)

Ref. No. 参照番号	Address 位置	New Parts 新	Parts No. 部品番号	Description 部品名 / 規格	Desti- nation 仕向	Re- marks 備考
D35			MA77	DIORD		
D301			MA728	DIORD		
D302			MA2S111	DIORD	XTBE2	
D302			MA2S111	DIORD	E3E9	
D302-305			MA2S111	DIORD	KP	
D302, 303			MA2S111	DIORD	MM2M3	
D304-306			MA2S111	DIORD	X	
D304-307			MA2S111	DIORD	E2	
D304-308			MA2S111	DIORD	TBE3E9	
D305-307			MA2S111	DIORD	M2M3M4	
D305-308			MA2S111	DIORD	M	
D307, 308			MA2S111	DIORD	KP	
D309, 310			DA227	DIORD		
D315			MA2S111	DIORD		
D316			MA8039	DIORD		
D317			MA2S111	DIORD		
D318			MA8062	DIORD		
D319, 320		*	B30-2131-05	LED		
D321			MA2S111	DIORD		
D322, 323			MA8039	DIORD		
D324			DAN222	DIORD		
D325			MA728	DIORD		
IC1		*	TK10930V	IC		
IC2			MC3372V	IC		
IC3		*	BU2090FS	IC		
IC4 ,5			MB1511PFV-G-BND	IC(PLL FREQUENCY SYNTHESIZER)		
IC6		*	MC12083D	IC		
IC9		*	KCH17	HIC(UHF VCO)		
IC10		*	KCH16	HIC(VHF VCO)		
IC11		*	TC7SU04FU	IC		
IC12			TC4W53FU	IC		
IC301			TC7660ME0A	IC		
IC302		*	AT24C16N10SI2.5	IC		
IC303		*	S-81335HG-KI	IC		
IC304		*	78056GC-016-3B9	IC(CPU)	XTMM2	
IC304		*	78056GC-016-3B9	IC(CPU)	M3M4E	
IC304		*	78056GC-016-3B9	IC(CPU)	E2E3E9	
IC304		*	78056GC-017-3B9	IC(CPU)	KP	
IC305		*	LC73881M	IC		
IC306			S-81235PG-PI	IC		
IC307		*	S-80730SL-AT	IC		
IC308			TA75W558FU	IC		
IC309		*	S-81340HG-KJ	IC		
IC310		*	PST9123NR	IC		
IC312		*	JLC1555F	IC		
IC313			TC4W53FU	IC		
IC314		*	BU2090FS	IC		
IC315, 316			NJM2070M	IC(OP AMP)		
IC317			LM301AD	IC(OP AMP)		
IC318		*	TC7SU04FU	IC		
Q1			2SD1483	TRANSISTOR		
Q3		*	UPA573T	FET		
Q4			2SC4619	TRANSISTOR		
Q5			UMA9	TRANSISTOR		
Q6 ,7		*	UPA573T	FET		

TH-79 A/E

PARTS LIST

× New Parts

Parts without Parts No. are not supplied.

Les articles non mentionnés dans le Parts No. ne sont pas fournis.

Teile ohne Parts No. werden nicht geliefert.

TX-RX UNIT(X57-440X-XX)

Ref. No. 参照番号	Address 位置	New Parts 新	Parts No. 部品番号	Description 部品名 / 規格	Desti- nation 仕 向	Re- marks 備考
Q8 ,9			2SC4619	TRANSISTOR		
Q10 ,11			2SC4738(GR)	TRANSISTOR		
Q12		*	UPA573T	FET		
Q14			2SC4617(R)	TRANSISTOR		
Q16			2SC4617(R)	TRANSISTOR		
Q17 ,18			2SA1832(GR)	TRANSISTOR		
Q19 ,20			2SC4738(GR)	TRANSISTOR		
Q21			2SC5066(O)	TRANSISTOR		
Q22			2SC4726(P,O)	TRANSISTOR		
Q23			UPA572T	FET		
Q24			2SC5066(O)	TRANSISTOR		
Q25			2SK1824	FET		
Q26			2SC5066(O)	TRANSISTOR		
Q27			2SC4726(P,O)	TRANSISTOR		
Q28			2SC4226(R24)	TRANSISTOR		
Q29			2SC4083(N,P)	TRANSISTOR		
Q30			2SC5066(O)	TRANSISTOR	KP	
Q30 ,31			2SC5066(O)	TRANSISTOR	XTMM2	
Q30 ,31			2SC5066(O)	TRANSISTOR	M3M4E	
Q30 ,31			2SC5066(O)	TRANSISTOR	E2E3E9	
Q32			2SC4738(GR)	TRANSISTOR		
Q33 ,34			2SC3356	TRANSISTOR		
Q35			2SC4726(P,O)	TRANSISTOR		
Q36			2SK1215(E)	FET		
Q37 ,38			2SC5066(O)	TRANSISTOR	XTMM2	
Q37 ,38			2SC5066(O)	TRANSISTOR	M3M4E	
Q37 ,38			2SC5066(O)	TRANSISTOR	E2E3E9	
Q38			2SC5066(O)	TRANSISTOR	KP	
Q39			3SK274	FET		
Q40			2SK1824	FET		
Q41			2SC5066(O)	TRANSISTOR	XTMM2	
Q41			2SC5066(O)	TRANSISTOR	M3M4E	
Q41			2SC5066(O)	TRANSISTOR	E2E3E9	
Q42			2SK1215(E)	FET		
Q43			2SC5066(O)	TRANSISTOR		
Q44			2SC4726(P,O)	TRANSISTOR		
Q301			UPA572T	FET		
Q302			2SK1588	FET		
Q303			UMC5	TRANSISTOR		
Q305			UPA572T	FET		
Q306 ,307			DTB113ZK	DIGITAL TRANSISTOR		
Q308			UMW1	TRANSISTOR		
Q309		*	2SB1188(O,R)	TRANSISTOR		
Q310			2SC4617(R)	TRANSISTOR		
Q311			2SB1182P5(O)	TRANSISTOR		
Q312			UMW1	TRANSISTOR		
Q313 ,314			DTC144EE	DIGITAL TRANSISTOR		
Q315 ,316			2SC4617(R)	TRANSISTOR		
Q317 ,318			2SK1824	FET		
Q319		*	UPA573T	FET		
Q320			UPA572T	FET		
Q321 ,322			2SJ243	FET		
Q323			UPA572T	FET		
Q324		*	UPA573T	FET		
Q325 ,326			2SJ243	FET		

TH-79 A/E

PARTS LIST

× New Parts

Parts without Parts No. are not supplied.

Les articles non mentionnés dans le Parts No. ne sont pas fournis.

Teile ohne Parts No. werden nicht geliefert.

TX-RX UNIT(X57-440X-XX)

Ref. No. 参照番号	Address 位置	New Parts 新	Parts No. 部品番号	Description 部品名 / 規格	Desti- nation 仕向	Re- marks 備考
Q327			DTC144BE	DIGITAL TRANSISTOR		
Q328			2SK879(Y)	FET		
Q329, 330			2SC4617(R)	TRANSISTOR		
Q331, 332		*	2SB1188(Q,R)	TRANSISTOR		
Q333, 334			DTA144WE	DIGITAL TRANSISTOR		
Q335			2SJ204	FET		
Q336			2SK879(Y)	FET		
Q337			UPA572T	FET		
Q338			2SC4738(GR)	TRANSISTOR		
Q339			2SK1588	FET		
Q340			2SK1824	FET		
TH1		*	TN103S472JT	THERMISTOR		
TH301, 302		*	TN103S472JT	THERMISTOR		
TH303, 304		*	TN103F102JT	THERMISTOR		

EXPLODED VIEW

A M2x7 :N09-2238-05
 G ϕ 2x5(P-Tap) :N80-2005-46

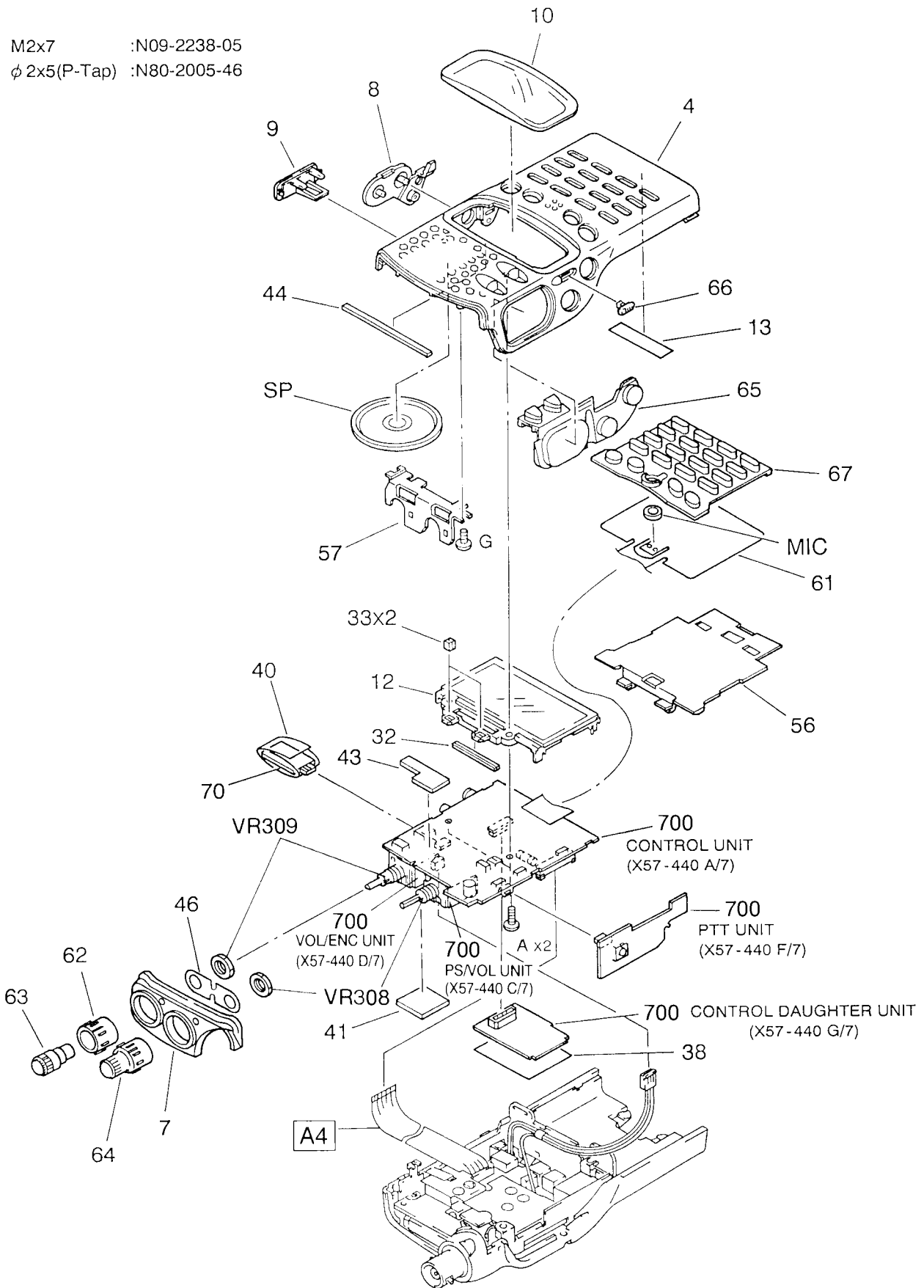

Parts with the exploded numbers larger than 700 are not supplied.

TH-79 A/E

EXPLODED VIEW

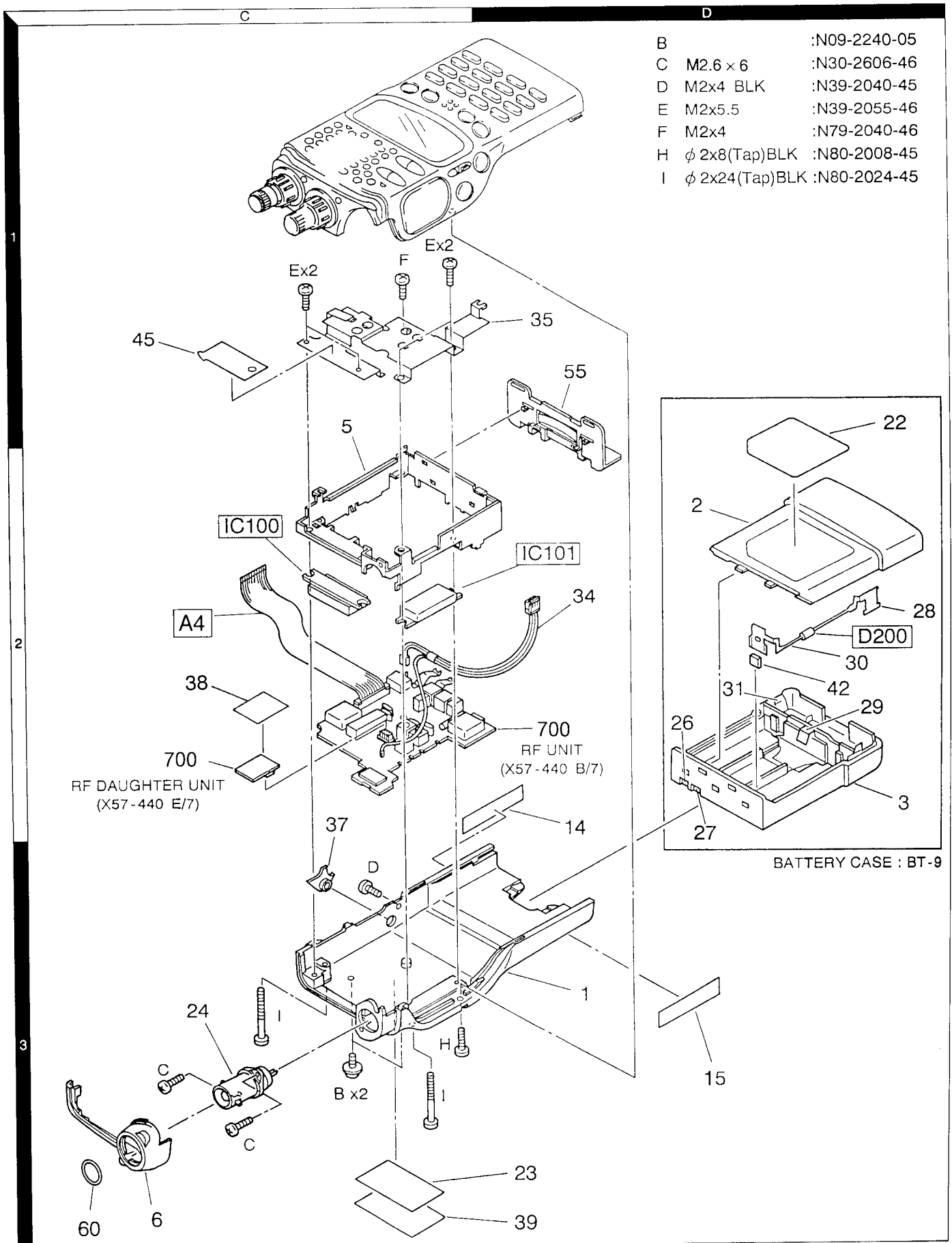

TH-79 A/E

PACKING

(X, M4 Type)

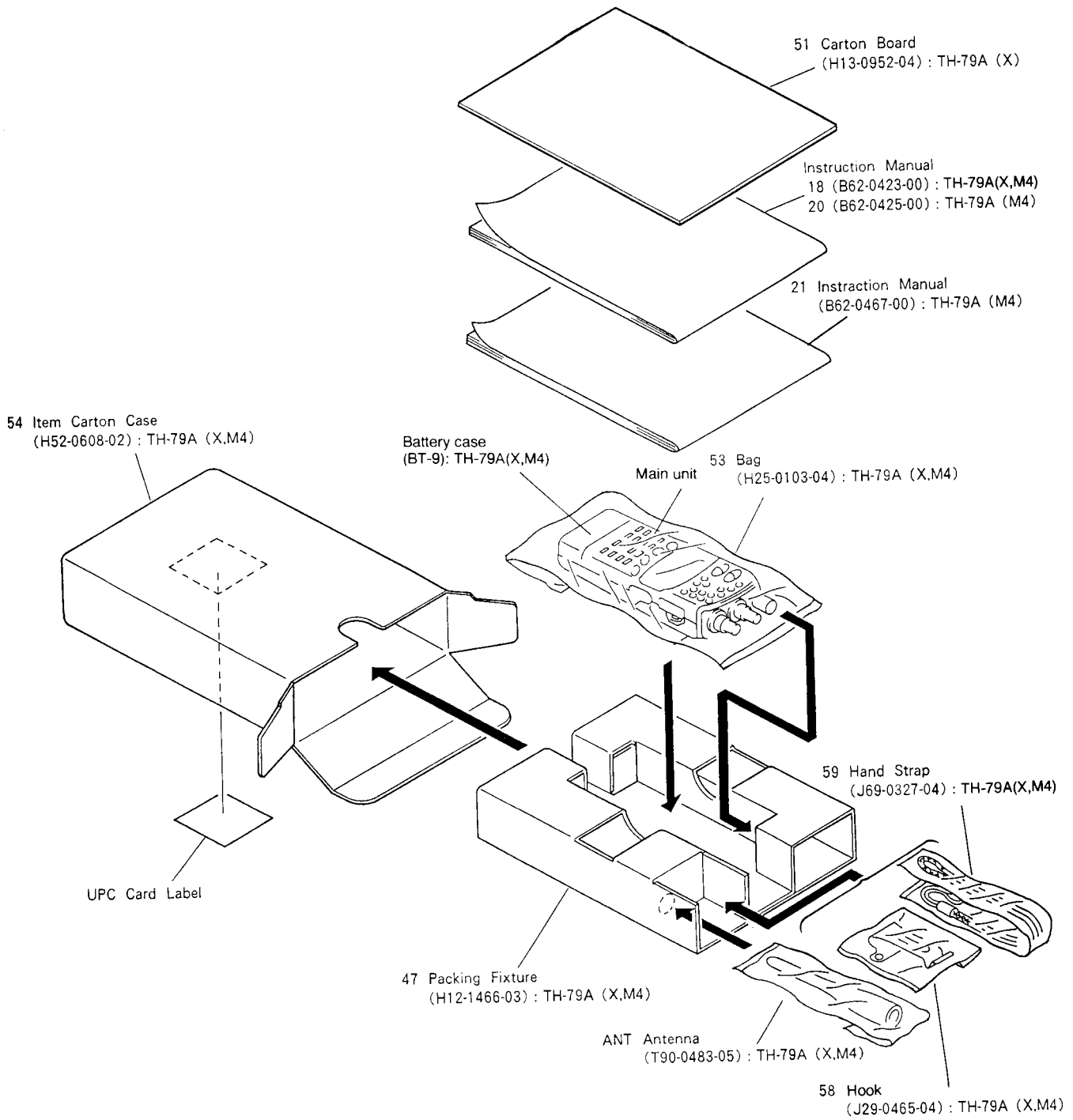

TH-79 A/E

PACKING

(EXCEPT X,M4 Type)

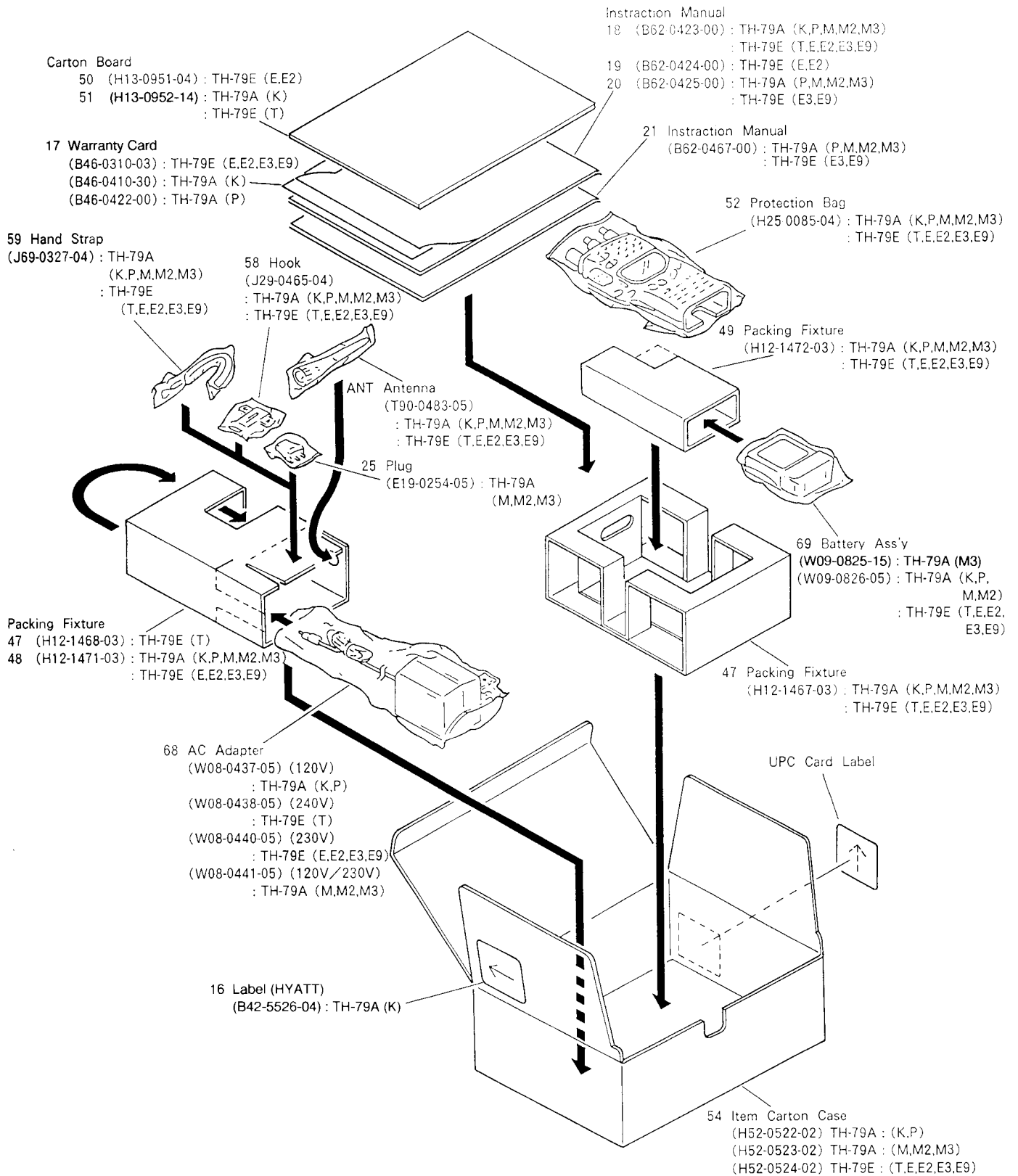

ADJUSTMENT

Required test equipment

1. Stabilized Power Supply

- 1) The supply voltage can be changed between 5V and 18V, and the current is 3A or more.
- 2) The standard voltage is 13.8V.

2. DC Ammeter

- 1) Class 1 ammeter (17 ranges and other features).
- 2) The full scale can be set to either 300mA or 3A.
- 3) A cable of less internal loss must be used.

3. Frequency Counter (f. counter)

- 1) Frequencies of up to 1GHz or so can be measured.
- 2) The sensitivity can be changed to 250MHz or below, and measurements are highly stable and accurate (0.2ppm or so).

4. Power Meter

- 1) Measurable frequency : Up to 500MHz.
- 2) Impedance : 50Ω, unbalanced.
- 3) Measuring range : Full scale of 10W or so.
- 4) A standard cable (5D2W 1m) must be used.

5. RF VTVM (RF V.M)

- 1) Measurable frequency : Up to 500MHz or so.

6. Linear Detector

- 1) Measurable frequency : Up to 500MHz.
- 2) Characteristics are flat, and CN is 60dB or more.

7. Digital Voltmeter

- 1) Voltage range : FS = 18V or so.
- 2) Input resistance : 1MΩ or more.

8. Oscilloscope

- 1) Measuring range : DC to 30MHz.
- 2) Provides highly accurate measurements for 5 to 25MHz.

9. AF Voltmeter (AF V.M)

- 1) Measurable frequency : 50Hz to 1MHz.
- 2) Maximum sensitivity : 1mV or more.

10. Spectrum Analyzer

- 1) Measuring range : DC to 1GHz or more.

11. Standard Signal Generator (SSG)

- 1) Maximum frequency : 500MHz or more.
- 2) Output : 0.05μV/ -133dBm ~ 0.1V/ -7dBm
- 3) Output impedance : 50Ω

12. Tracking Generator

- 1) Center frequency : 50kHz to 200MHz.
- 2) Frequency deviation : ±35MHz.
- 3) Output voltage : 100mV or more.

13. Dummy Load

- 1) 8Ω, 3W or more.

Preparation

- Set the unit in the receiving mode and set the controls as follows, unless otherwise specified.

VHF AF VR.....	MIN
UHF AF VR.....	MIN
LOW KEY.....	HI

- Use a non-conductive rod such as a Bakelite rod for adjustment (especially of trimmers and coils).
- To protect the SSG, do not send out signals while adjusting the receiving unit.
- The indicated SSG output levels are for maximum output.

And whenever there is no modulation designation, standard modulation (MOD: 1kHz, DEV: ±3kHz) is indicated.

Service jig for adjustment

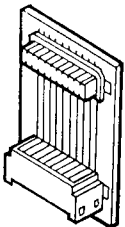

Connector PC board
(E29-1138-05)

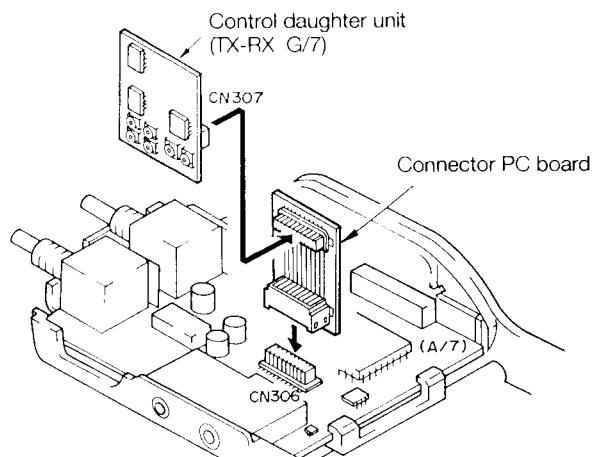

Note : Connect with the connector PC board inserted as shown in the figure.

TH-79 A/E

ADJUSTMENT

How to use the "Set Mode"

About the "Set Mode"

When this unit is placed in the "Set Mode," the following levels can be set.

1. Each band's squelch critical point
2. Each band's S meter first group illumination
3. Each band's S meter total illumination
4. Excessive voltage warning reference voltage (13.8V)

Levels set in the "Set Mode" are written to the E²PROM. As a result, the written data is preserved even if the power supply is cut off or the unit is reset.

Also, if the E²PROM is replaced, all items need to be rewritten (reset).

Setting procedures

1. Set the dual band mode for use (DUAL) key .
2. Open the main unit. With the power on, momentarily short the TX-RX unit (A/7) part surface test point TB 1 and TB 2 with tweezers equipment.
 - The LCD's non-actuated band side displays ~~Set Mode~~, indicating that the Set Mode has been entered.
 - Key functions during "Set Mode" are as follows.
 - (1) : Squelch critical point (■ □ □ □ □) setting
 - (2) : S meter first group illumination level setting
 - (3) : S meter total illumination level setting
 - (4) : Excessive voltage warning reference voltage (13.8V) recognition setting
 - (5) : Excessive voltage warning recognition mode (warning sounds)
 - (6) : Cancellation of (5) (turning the power off is also possible)
 - (LOW) : V × V / U × U changeover
 - (DUAL) : 430/800 or 144/300's changeover
 - (SHIFT) , (DUAL) , (DUAL) : 300's AM/FM changeover (During Set Mode, the F, MENU, SQL, REV, 0 and 7~9 keys do not receive.)

Example : E,T type

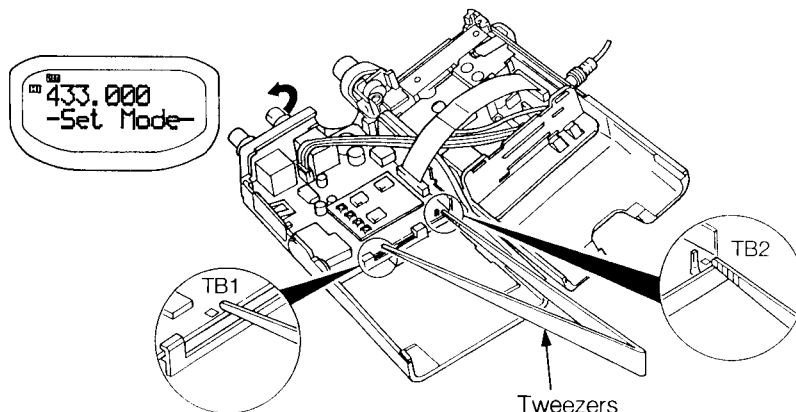

3. Input each band's designated SSG level from the ANT terminal and press each SET key. (Table below)

Band (SSG FREQ.)	Push Key		
	(1)	(2)	(3)
UHF(439.94MHz)	-128dBm (0.09μV)	-121dBm (0.2μV)	-111dBm (0.63μV)
VHF(145.94MHz)	-128dBm (0.09μV)	-122dBm (0.18μV)	-112dBm (0.56μV)
Sub-U(439.94MHz)	-127dBm (0.1μV)	-120dBm (0.23μV)	-110dBm (0.7μV)
Sub-V(145.94MHz)	-127dBm (0.1μV)	-120dBm (0.23μV)	-110dBm (0.7μV)
300/FM(380.025MHz)	-128dBm (0.09μV)	/	/
300/AM(380.025MHz)	-122dBm (0.18μV)	/	/
AIR/AM(120.025MHz)	-122dBm (0.18μV)	/	/
800/FM(860.080MHz)	-122dBm (0.18μV)	/	/

4. Excessive voltage warning reference voltage (13.8V) recognition setting
Apply a terminal voltage of 13.8V±0.05V from a stabilizing power supply connected to the external power supply terminal (DC IN) and press key (4) .
Next press key (5) and confirm that a warning sound can be heard.
5. The "Set Mode" is cleared when the power is turned off.
6. Turn on the power supply while pressing (VFO) and reset VFO.

(Note 1) Each setting overwrites the previous data, so they can be set independently and in any order.

(Note 2) Even if reception expansion is not done, the 300, 800 and AIR squelch settings can be done.

(Note 3) Switching from AIR can be operated from VHF by the encoder.

ADJUSTMENT

Common section

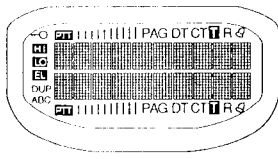
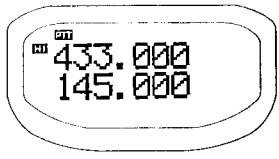
Item	Condition	Measurement point			Adjustment point		Specifications
		Test-equipment	Unit	Terminal	Unit	Parts	
1. Setting and resetting	1) External power supply connection DC IN terminal voltage : 6V 2) Total illumination display confirmation Turn the power switch on while pressing the F key 3) All-resetting and initial value setting Press the F key once again within 10 seconds after total illumination	LCD total illumination display			Initial value setting display after all-resetting		
							Example : E,T Type

VHF receiver section

1. Helical (BPF)	1) Trajene output: -45dBm Center : 146.0MHz Span : 50MHz Ref : -20dBm	Trajene spectrum analyzer	TX-RX (B/7)	TP ANT	TX-RX (B/7)	L19 L36	Adjust to the maximum level with the two markers within 2dB.	Refer to Fig.1
2. Large input S/N	1) Frequency : 145.050MHz : E,T 146.050MHz : K,P,X,M SSG : -73dBm (50μV)	SSG EXT · SP Oscilloscope AFVM Distortion factor meter		ANT SP			After confirming the S/N, confirm the audio output (AF · VR : MAX)	40dB or more 1.3V or more
3. Sensitivity	1) Frequency : 145.050MHz : E,T 146.050MHz : K,P,X,M SSG : -122dBm (0.18μV)						Confirmation	12dB SINAD or more
	2) Frequency : 144.050MHz							
	3) Frequency : 145.950MHz : E,T 147.950MHz : K,P,X,M 4) Frequency : 128.025MHz : K,P SSG : -113dBm (0.5μV) (AM MOD 1kHz 60%)							S/N 10dB or more
4. Consumption current	1) Frequency : 145.950MHz : E,T 147.950MHz : K,P,X,M SSG : OFF					Confirmation	50mA or less	
5. S meter	1) Frequency : 144.050MHz SSG : -122dBm ±3dBm	SSG		ANT		LCD	Confirmation	■■■■■■■■■■ 1 group or more illuminates
6. Tight squelch	1) Frequency : 144.050MHz SQL · VR : MAX SSG : OFF						After pressing SQL · VR, rotate the encoder right to make the display become ■■■■■■.	Close squelch
	2) SSG : -113dBm (0.5μV)							Open squelch

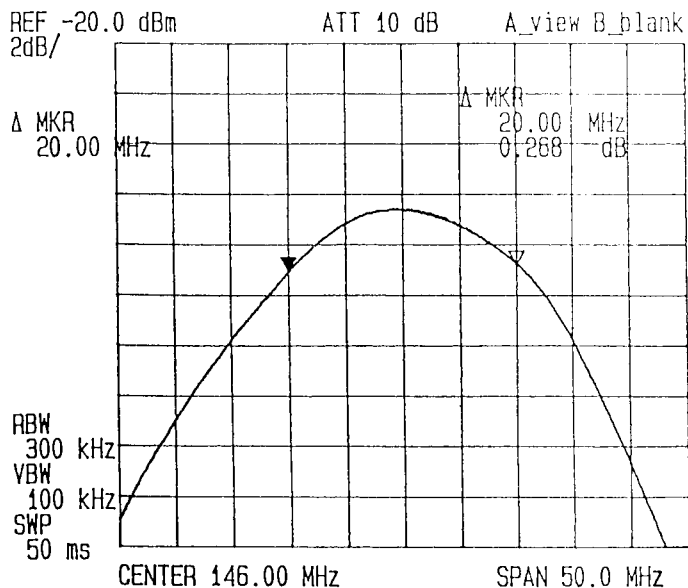

Fig.1 Helical(BPF) adjustment waveform
VHF BAND

TH-79 A/E

ADJUSTMENT

SUB-UHF receiver section

Item	Condition	Measurement point			Adjustment point			Specification
		Test-equipment	Unit	Terminal	Unit	Parts	Method	
1. Large inout S/N	1) Frequency : 435.050MHz : E,M,T,X 444.050MHz : K,P SSG : -73dBm(50μV)	SSG EXT · SP Oscilloscope AFVM Distortion factor meter		ANT SP			Confirmation	34dB or more
2. Sensitivity	1) Frequency : 435.050MHz : E,M,T,X 444.050MHz : K,P SSG : -117dBm(0.32μV)						Confirmation	12dB SINAD or more
	2) Frequency : 430.050MHz : E,M,T,X 438.050MHz : K,P							
	3) Frequency : 439.950MHz : E,M,T,X 449.950MHz : K,P							
3. S meter	1) Frequency : 435.050MHz : E,M,T,X 444.050MHz : K,P SSG : -120dBm ±3dBm	SSG		ANT	Panel	LCD	Confirmation	■■■■■■■■■■ 1 group or more illuminates

UHF receiver section

1. Large inout S/N	1) Frequency : 435.050MHz : E,M,T,X 444.050MHz : K,P SSG : -73dBm(50μV)	SSG EXT · SP Oscilloscope AFVM Distortion factor meter Ammeter		ANT SP			Confirmation	34dB or more
2. Sensitivity	1) Frequency : 435.050MHz : E,M,T,X 444.050MHz : K,P SSG : -121dBm(0.2μV)						Confirmation	12dB SINAD or more
	2) Frequency : 430.050MHz : E,M,T,X 438.050MHz : K,P							
	3) Frequency : 439.950MHz : E,M,T,X 449.950MHz : K,P							
3. Consumption current	1) Frequency : 439.950MHz : E,M,T,X 449.950MHz : K,P SSG : OFF						Confirmation	50mA or less
4. S meter	1) Frequency : 435.050MHz : E,M,T,X 444.050MHz : K,P SSG : -121dBm ±3dBm	SSG		ANT		LCD	Confirmation	■■■■■■■■■■ 1 group or more illuminates
5. Tight squelch	1) Frequency : 435.050MHz : E,M,T,X 444.050MHz : K,P SQL level : MAX SSG : OFF						After pressing SQL key, rotate the encoder right to make the display becom ■■■■■.	Close squelch
	2) SSG : -113dBm(0.5μV)						Confirmation SQL level return ■■■■■.	Open squelch

SUB-VHF receiver section

1. Large input S/N	1) Frequency : 145.050MHz : E,T 146.050MHz : K,P,X,M SSG : -73dBm(50μV)	SSG EXT · SP Oscilloscope AFVM Distortion factor meter		ANT SP			Confirmation	34dB or more
2. Sensitivity	1) Frequency : 145.050MHz : E,T 146.050MHz : K,P,X,M SSG : -117dBm(0.32μV)						Confirmation	12dB SINAD or more
	2) Frequency : 144.050MHz							
	3) Frequency : 145.950MHz : E,T 147.950MHz : K,P,M,X							
3. S meter	1) Frequency : 144.050MHz SSG : -120dBm ±3dBm	SSG		ANT		LCD	Confirmation	■■■■■■■■■■ 1 group or more illuminates

ADJUSTMENT

UHF Transmitter section

Item	Condition	Measure point			Adjustment point			Specification
		Test-equipment	Unit	Terminal	Unit	Parts	Method	
1. Transmission frequency	1) Frequency : 439.975MHz : M,E,T,X 449.975MHz : K,P PTT : ON	Power meter f counter		ANT	TX-RX (B/7)	TC1	Match to display frequency	± 200Hz
2. Power	1) BATT TERMINAL : 9.6V Frequency : 430.000MHz : M,E,T,X 438.000MHz : K,P HI/LOW : EL PTT : ON	Power meter Ammeter		ANT	TX-RX (G/7)	VR307	Adjust to 30mW	± 5mV
	2) HI/LOW : HI PTT : ON					VR305	Adjust to 4.5W Consumption current confirmation	± 0.1W 1.8A or less
	3) Frequency : 434.975MHz : M,E,T,X 444.000MHz : K,P Frequency : 439.975MHz : M,E,T,X 449.975MHz : K,P						Confirmation	4.3-5.3W
	4) BATT TERMINAL : 4.8V Frequency : 439.975MHz : M,E,T,X 449.975MHz : K,P						Confirmation (Reduce voltage)	1.0W or more
	5) DC · IN : 13.8V Frequency : 434.975MHz : M,E,T,X 444.000MHz : K,P PTT : ON						Confirmation	4.5-7.3W 1.95A or less
3. DEV	1) Frequency : 430.000MHz : M,E,T,X 438.000MHz : K,P AG : 1kHz/ 35mV PTT : ON	Power meter Linear detector Oscilloscope AG AFVM		ANT	TX-RX (G/7)	VR301	Adjust to 4.2kHz according to the larger ±	± 100Hz
	2) AG : 20dB down (1kHz/3.5mV) PTT : ON						Confirmation (Microphone sensitivity)	± 2.6-3.5kHz
4. TONE DEV	1) Frequency : 430.000MHz : T,E 438.000MHz : K,P F → Press TONE key to display "T" PTT : ON Frequency : 430.000MHz : M,X TONE Push PTT : ON						Display confirmation TONE DEV confirmation	"T" display illumination ± 0.5-1.6kHz : K,P,M,X ± 2.5-4.5kHz : T,E
	5. DTMF DEV						1) Press the D key in transmission mode	

VHF Transmitter section

1. Power	1) BATT TERMINAL : 9.6V Frequency : 144.000MHz HI/LOW : EL PTT : ON	Power meter Ammeter		ANT	TX-RX (G/7)	VR306	Adjust to 30mW	± 5mV
	2) HI/LOW : HI Frequency : 145.975MHz : K,P,M,X 147.975MHz : E,T PTT : ON					VR304	Adjust to 5.5W Consumption current confirmation	± 0.1W 1.6A or less
	3) Frequency : 144.975MHz : E,T 146.000MHz : K,P,M,X Frequency : 144.000MHz Frequency : 145.975MHz : E,T 147.975MHz : K,P,M,X						Confirmation	5.0-6.0W
	4) BATT TERMINAL : 4.8V Frequency : 147.975MHz : K,P,M,X 145.975MHz : E,T						Confirmation (Reduce voltage)	1.0W or more
2. DEV	1) Frequency : 147.975MHz : K,P,M,X 145.975MHz : E,T AG : 1kHz/ 35mV PTT : ON	Power meter Linear detector Oscilloscope AG AFVM		ANT	TX-RX (G/7)	VR302	Adjust to 4.2kHz according to the larger ±	± 100Hz
	2) AG : 20dB down (1kHz/3.5mV) PTT : ON						Confirmation (Microphone sensitivity)	± 2.6-3.5kHz

Other section

1. LCD contrast	1) Ta = +25°C	Disital voltmeter	CONT (A/7)	TA	CONT (A/7)	VR303	Adjust to 1.5V	± 0.1V
-----------------	---------------	----------------------	---------------	----	---------------	-------	----------------	--------

TH-79 A/E

ADJUSTMENT

Parts layout

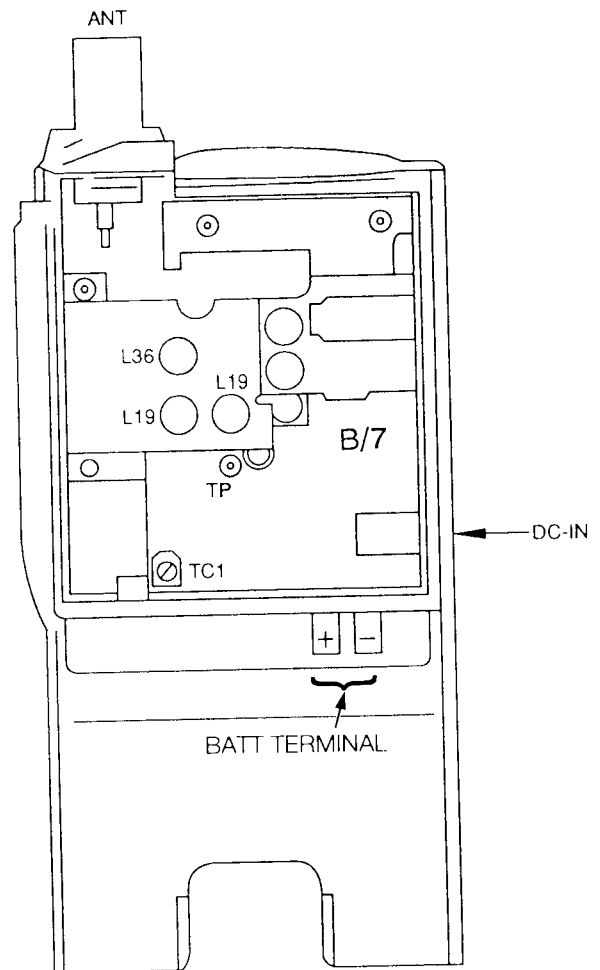
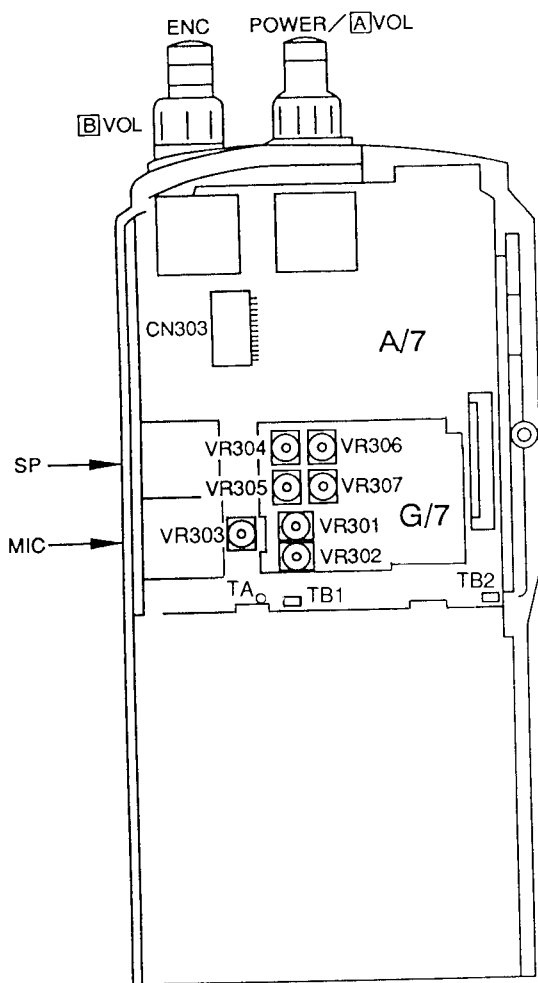

TX-RX UNIT(G/7)

- VR301 : DEV(UHF)
- VR302 : DEV(VHF)
- VR304 : HI POWER(VHF)
- VR305 : HI POWER (UHF)
- VR306 : EL POWER(VHF)
- VR307 : EL POWER(UHF)

TX-RX UNIT(B/7)

- L19,36 : VHF Helical
- TC1 : Transmission frequency (UHF)
- TP : Helical adjustment
Spectrum analyzer

TX-RX UNIT(A/7)

- TA : LCD contrast point
- TB1,TB2 : SET mode test point
- VR303 : LCD contrast adjustment

TERMINAL FUNCTION

Connector No.	Pin No.	Pin name	Function
CN1, CN302	1	3C	Each receiver circuit, PLL power supply
	2	MDV	VHF modulation
	3	DP	Data
	4	EV	VHF enable
	5	CP	Clock
	6	AFV	VHF audio
	7	ULV	VHF unlock
	8	AFU	UHF audio
	9	ULU	UHF unlock
	10	GND	GND
	11	3MRF	UHF 1st AMP SW
	12	SHU	UHF shift
	13	7C	Charge pump power supply
	14	DS2	Shift register data
	15	SHV	VHF shift
	16	SQU	UHF squelch
	17	BSH	VHF band shift
	18	SQV	VHF squelch
	19	3TU	UHF transmission power supply
	20	SMU	UHF S meter
	21	APCV	VHF APC
	22	SMV	VHF S meter
	23	3TV	VHF transmission power supply
	24	EU	UHF enable
	25	APCU	UHF APC
	26	MDU	UHF modulation

Connector No.	Pin No.	Pin name	Function
CN303	1	RD	Tone input
	2	3MS	TSU-8 power supply
	3	GND	GND
	4	SDO	Tone coincidence detection
	5	TX	NC
	6	ET	Tone enable
	7	DT	Data
	8	CK	Clock

Connector No.	Pin No.	Pin name	Function
CN2, CN3	1	GND	GND
	2	GND	GND
	3	LO.IN	1st local
	4	3RSU	Sub-UHF power supply
	5	NC	NC
	6	RF.IN	RF input
	7	IF.OUT	IF output
	8	3R36	360MHz power supply
	9	GND	GND
	10	GND	GND

TH-79 A/E

TERMINAL FUNCTION

Connector No.	Pin No.	Pin name	Function
CN306, CN307	1	CP	Clock
	2	TONE	Tone
	3	3TU	UHF transmission voltage
	4	RB	APC current detection, power module power supply
	5	3M	Microprocessor E ² PROM power supply(IC306 output)
	6	3T	Transmission power supply
	7	APC	APC
	8	3TV	VHF transmission voltage
	9	7C	Charge pump voltage
	10	3C	Each receiver circuit, PLL power supply
	11	SDA	E ² PROM data
	12	GND	GND
	13	EL	Economic low power switch
	14	LOW	LOW power switch
	15	MDV	VHF modulation
	16	3MS	Each AVR reference Xpoint switch power supply(IC306 output)
	17	MSV	VHF modulation SW
	18	MSU	UHF modulation SW
	19	SB	Power supply
	20	MDU	UHF modulation
	21	MIN	Microphone input
	22	XIN	Cross-band repeater, DTMF input

WIRING DIAGRAM TH-79 A/E

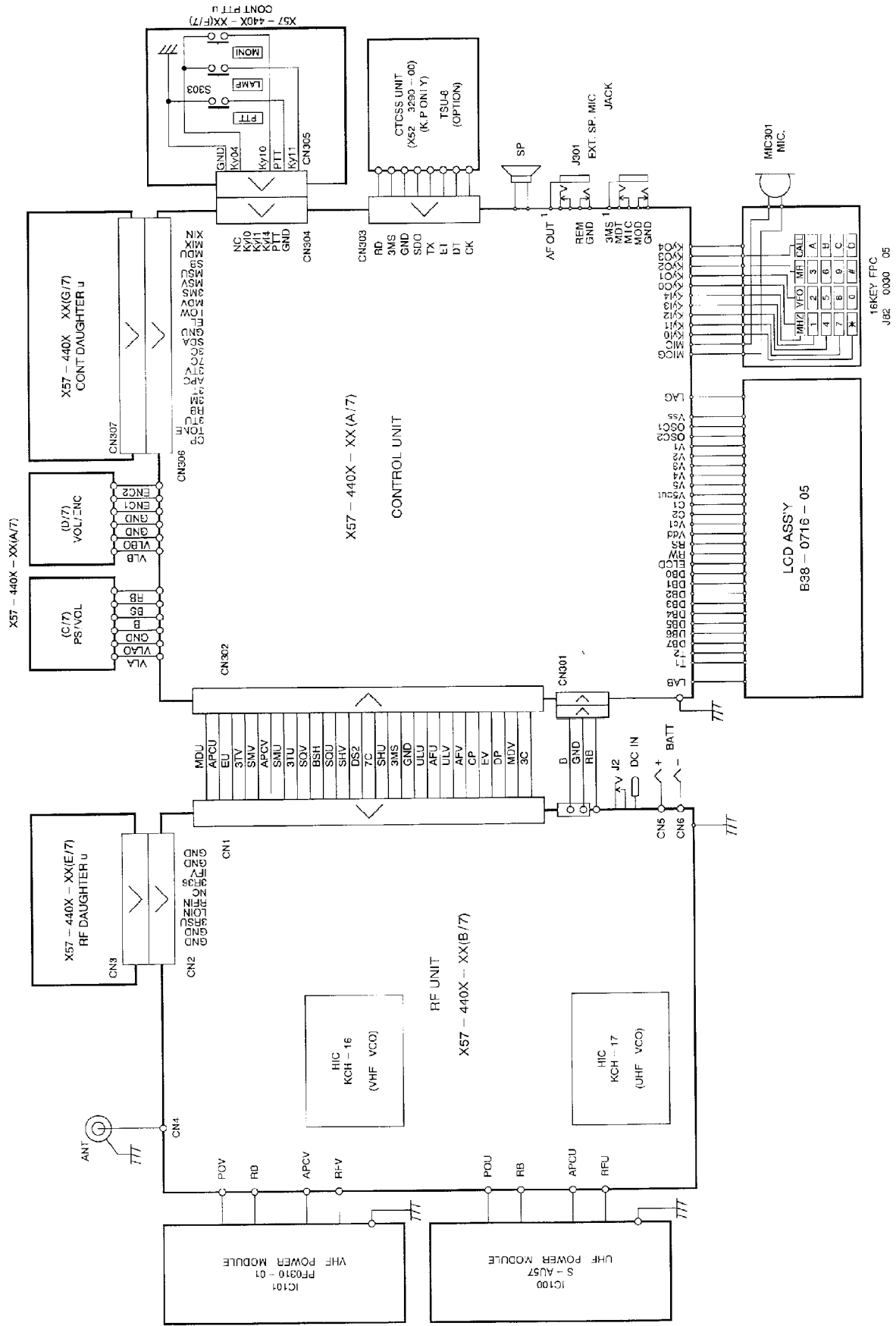

CTCSS UNIT(X52-3290-00) : TSU-8 SC-41/ 42/ 43 (SOFT CASE) , BT-9(BATTERY CASE)

CTCSS UNIT(X52-3290-00) : TSU-8

The details refer to TSU-8 Service Manual(B51-8248-00).

SCHEMATIC DIAGRAM

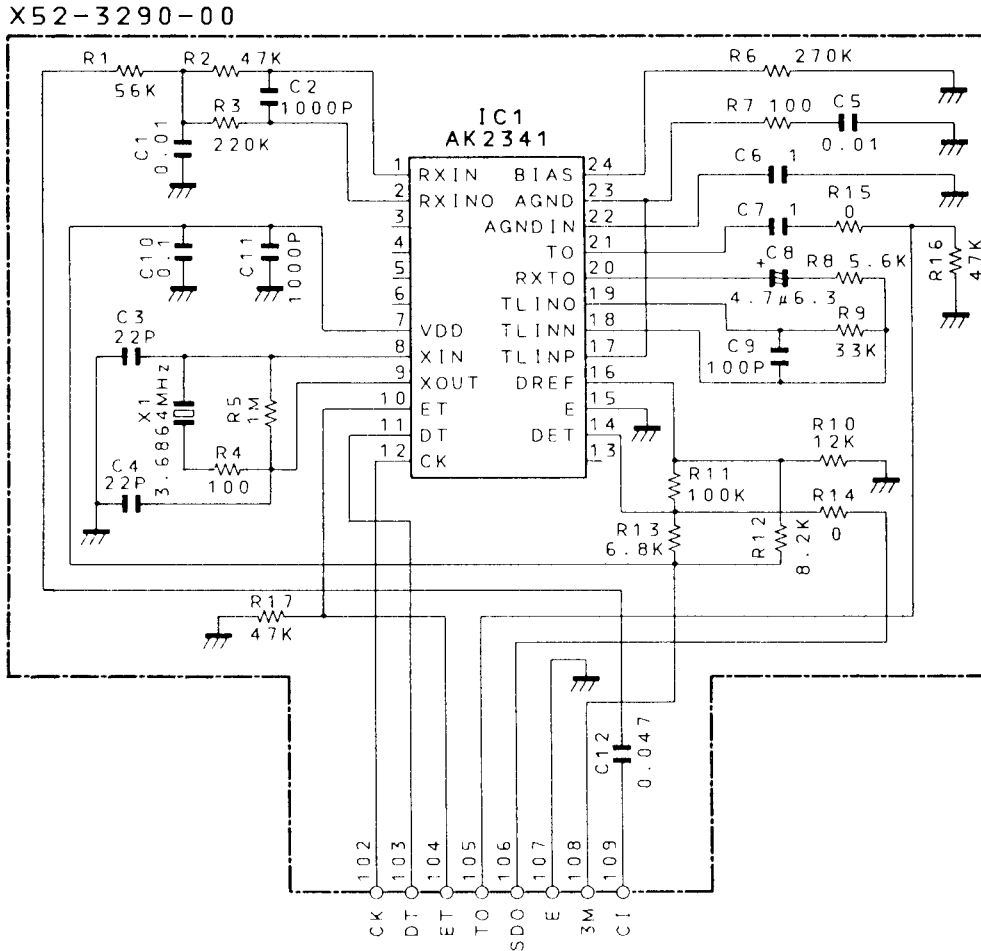

SC-41 EXTERNAL VIEW

SC-42 EXTERNAL VIEW

SC-43 EXTERNAL VIEW

BT-9 EXTERNAL VIEW

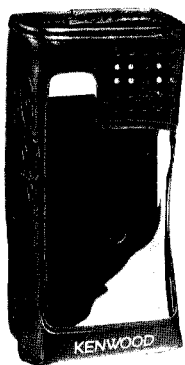

S SIZE
(With PB-30/32)

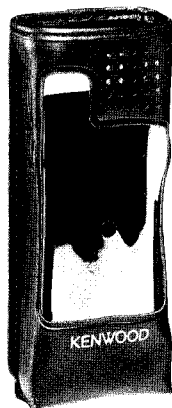

M SIZE
(With PB-31/BT-9)

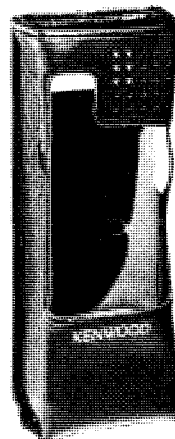

L SIZE
(With PB-33/34)

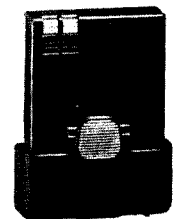

TH-79 A/E

SPECIFICATIONS

General		144 MHz Band		430/440 MHz Band	
Frequency range		V	V ²	U	U ²
U.S.A./Canada		144 ~ 148 MHz	144 ~ 148 MHz	438 ~ 450 MHz	438 ~ 450 MHz
Europe		144 ~ 146 MHz	144 ~ 146 MHz	430 ~ 440 MHz	430 ~ 440 MHz
General market		144 ~ 148 MHz	144 ~ 148 MHz	430 ~ 440 MHz	430 ~ 440 MHz
Mode		F3E (FM)			
Usable temperature range		-20°C ~ +60°C (-4°F to +140°F)			
Grounding		Negative ground			
Dimensions ¹ (W x H x D)		56 mm x 129.5 mm x 24.5 mm / 2.20 in x 5.10 in x 0.965 in			
Dimensions ¹ (projections included)		63.5 mm x 144.0 mm x 31.0 mm / 2.50 in x 5.67 in x 1.22 in			
Weight ²		Approx. 325 g / 11.5 oz			
Microphone impedance		2 kΩ			
Antenna impedance		50 Ω			
Supply voltage (rated voltage)	External power, DC jack	5.5 V ~ 16.0 V (13.8 V)			
	Battery terminals	4.5 V ~ 15.0 V (6.0 V)			
Current	RX (no signal)(dual-band)	Approx. 80 mA			
	RX (no signal)(single-band)	Approx. 45 mA			
	Battery Saver ON	Approx. 20 mA			
	TX (HI, 13.8 V, DC jack)	Approx. 1.3 A		Approx. 1.8 A	
	TX (HI, 9.6 V, battery terminals)	Approx. 1.3 A		Approx. 1.8 A	
	TX (HI, 6.0 V, battery terminals)	Approx. 1.3 A		Approx. 1.8 A	
	TX (HI, 4.8 V, battery terminals)	Approx. 1.2 A		Approx. 1.6 A	
	TX (LO, 6.0 V, battery terminals)	Approx. 0.6 A		Approx. 0.6 A	
	TX (EL, 6.0 V, battery terminals)	Approx. 300 mA			
Transmitter		144 MHz Band		430/440 MHz Band	
Output power	HI, 13.8 V, DC jack	Approx. 5 W		Approx. 5 W	
	HI, 9.6 V, battery terminals	Approx. 5 W		Approx. 5 W	
	HI, 6.0 V, battery terminals	Approx. 2.7 W		Approx. 2.0 W	
	HI, 4.8 V, battery terminals	Approx. 1.5 W		Approx. 1.5 W	
	LO, 6.0 V, battery terminals	Approx. 0.5 W			
	EL, 6.0 V, battery terminals	Approx. 30 mW			
Modulation		Reactance			
Maximum frequency deviation		Within ±5 kHz			
Spurious emissions		-60 dB or less			
Receiver		144 MHz Band		430/440 MHz Band	
Circuitry		Double conversion superheterodyne			
1st intermediate frequency		38.85 MHz		45.05 MHz	
2nd intermediate frequency		450 kHz		455 kHz	
Sensitivity (12 dB SINAD)	V or U	0.16 μV or less		0.18 μV or less	
	V ² or U ²	0.25 μV or less		0.25 μV or less	
Squelch sensitivity		0.1 μV or less			
Selectivity (-6 dB)		12 kHz or more			
Selectivity (-40 dB)		28 kHz or less			
Audio output (10% distortion, 8 Ω load)		200 mW or higher			

- Specifications apply only when using the V or U band. They do not apply to the V² or U² band.
- Specifications are subject to change without notice due to developments in technology, and are guaranteed within Amateur bands only.

¹ PB-32 included.

² Antenna, hand strap, belt hook,
and PB-32 included.

KENWOOD CORPORATION

14-6, Dogenzaka 1-chome, Shibuya-ku, Tokyo 150, Japan

KENWOOD SERVICE CORPORATION

P.O. BOX 22745, 2201 East Dominguez Street, Long Beach, CA 90801-5745, U.S.A.

KENWOOD ELECTRONICS DEUTSCHLAND GMBH

Rembrücker Str. 15, 6056 Heusenstamm, Germany

KENWOOD ELECTRONICS BENELUX N.V.

Mechelsesteenweg 418 B-1930 Zaventem, Belgium

TRIO-KENWOOD FRANCE S.A.

13, Boulevard Ney, 75018 Paris, France

TRIO-KENWOOD U.K. LIMITED

KENWOOD House, Dwright Road, Watford, Herts., WD1 8EB United Kingdom

KENWOOD ELECTRONICS NEDERLAND B.V.

Amsterdamseweg 35, 1422 AC Uithoorn, The Netherlands

KENWOOD ELECTRONICS ITALIA S.p.A.

Via G. Sirtori, 7/9 20129 Milano, Italy

KENWOOD ESPAÑA S.A.

Bolivia, 239-08020 Barcelona, Spain

KENWOOD ELECTRONICS AUSTRALIA PTY. LTD.

(A.C.N. 001 499 074)

P.O. Box 504, 8 Figtree Drive, Australia Centre, Homebush, N.S.W. 2140, Australia

KENWOOD & LEE ELECTRONICS, LTD.

Unit 3712-3724, Level 37, Tower one Metroplaza, 223 Hing Fong Road, Kwai Fong, N.T., Hong Kong

KENWOOD ELECTRONICS CANADA INC.

6070 Kestrel Road, Mississauga, Ontario, Canada L5T 1S8