



DIVISIONE ELETTRONICA E SISTEMI

IFX4N

**DIGITAL OVERCURRENT AND EARTH FAULT
MULTIFUNCTION RELAY**

USER MANUAL

P500D802

April 2005

INDEX

1	GENERAL CHARACTERISTICS.....	1
2	FRONT PANEL KEYS.....	4
3	FRONT PANEL LED SIGNALINGS.....	5
4	PROGRAMMING AND TEST.....	6
4.1	How to program the protection relay.....	6
4.2	How to modify a visualized parameter.....	7
4.3	Reset.....	7
4.4	Test of output relays.....	8
5	DISPLAY AND PROGRAMMING.....	9
5.1	Standard display.....	9
5.2	Visualization structure.....	10
5.3	Address and Time (fig. 1).....	13
5.4	Protection function selection (fig. 1).....	14
5.5	Nominal values set-up (fig. 2).....	14
5.6	Thresholds and time delays set-up (fig. 2).....	16
5.7	Output relays programming (fig. 2).....	18
5.8	Digital inputs function programming (fig. 2).....	19
5.9	Parameter values visualization (fig. 3).....	20
5.10	Events (fig. 3).....	21
5.11	TRIPS COUNTERS.....	23
6	INSTALLATION.....	25
6.1	Supplied kit.....	25
6.2	Cabling.....	26
6.3	Relays R3 and R4 - Signaling / Command set-up.....	29
6.4	RS485 serial communication port.....	29
7	TIME DEPENDENT CURVES.....	30
8	TECHNICAL CHARACTERISTICS.....	31
9	TABLES.....	32

Information printed in this manual subject to change without prior notice.

This manual must not be reproduced in whole or in part, in any form or by any means without the express written permission of SEB Divisione Elettronica e Sistemi.

1 GENERAL CHARACTERISTICS

The protection relay IFX4N performs functions such as overcurrent and earth fault relay; the user can select one of the functions listed in the table below.

Functions	ANSI	Measured currents
Two-phase overcurrent	50 51	I1, I2
Three-phase overcurrent	50 51	I1, I2, I3
Two-phase overcurrent + earth fault	50 51 51N	I1, I2, Io
Three-phase overcurrent + earth fault	50 51 51N	I1, I2, I3, Io
Earth fault (non directional)	51 N	Io
Stator earth fault (95%)	64 S	Io
Transformer case earth fault	64 T	Io

All the set-up and measured parameters can be visualized on the front panel display and transmitted on the RS485 communication serial port.

THRESHOLDS - the following thresholds are available:

- phase overcurrent thresholds $I > , I >> , I >>>$
- earth fault overcurrent thresholds $I_o > , I_o >> , I_o >>>$

The available settings for each threshold are listed in Table A.

Related to each threshold, partial and total counters of TRIP conditions are available.

TRIP DELAYS - a programmable time delay (TI) is available for each threshold; it can be programmed as definite time or dependent time in compliance with IEC 255-4 standard.

For each threshold programmed as definite time, an additional programmable time delay (TA) is available; the additional time delay is added to time delay TI. The additional time delay activation is controlled by the digital inputs to allow the use of the IFX4N relay with cooperating protection relays.

The available settings for each timers are listed in Table A.

OUTPUT RELAYS - the IFX4N controls 4 output relays (named R1, R2, R3 and R4); these relays can be programmed to be activated on START or TRIP conditions of one or more thresholds.

START	instantaneous activation of the output relay when at least one of the measured currents exceeds the programmed threshold value
TRIP	activation of the output relay when the programmed time delay (TI or TI+TA) related to a threshold expires.

The quiescent state of each single relay R1, R2, R3 and R4 can be programmed as normally energized (ON) or normally de-energized (OFF).

An additional relay R5 (normally energized) is controlled by the self-diagnosis routines to report detected fault conditions.

DIGITAL INPUTS - there are available 3 digital inputs to activate the following functions (when enabled by the programmed set-up):

- additional time delay (related to one or more thresholds)
- on/off thresholds
- STATUS function (recording of measures on external event)
- pilot wire fault monitoring

For each digital input can be programmed the condition that activates the related functions:

HI voltage =	> 20 V dc / ac
LO voltage =	0 ÷ 10 V dc / ac

The digital input acquisition is valid when the voltage value stays in the range HI or LO for at least 40 ms.

DISPLAY OF MEASURES - the user can select the continuous display of a measured current (primary values); all the current measures can be transmitted to an external controller through the RS485 port.

EVENTS - information related to the last 8 events (TRIP or STATUS) are recorded in the EEPROM memory.

Information includes the threshold set-up and activated relays (TRIP event only), the measured currents, the digital input status, date and time of the event.

SELF-DIAGNOSIS - the software includes a non stop monitoring module that controls the functionality of all hardware and software resources of the protection relay.

Detected fault conditions are reported by:

- diagnostic message on the display
- glow of a red LED on front panel
- R5 output relay drop-off

The fault condition signaling stays until faults are pointed out by the monitoring module; during this condition the protection functions are suspended to avoid unsuitable tripping.

STATUS FUNCTION - when the STATUS function is activated by one of the digital input (when programmed) the protection relay memorizes information related to measured currents and digital input status (see par. 5.10 - EVENTS). The recorded information allows an analysis of trip causes in co-operative protection relays systems.

PILOT WIRE FAULT MONITORING - when the function is programmed, the digital input DIG2 is used to control the correct functionality of the pilot wire. Digital input DIG2 is always expected to be complementary of DIG1 input (HI-LO or LO-HI) to identify faults on pilot wire.

The fault condition is reported as detected by the self-diagnosis module but the protection functions are not suspended; only the functions related to DIG1 digital input are suspended as the DIG1 status cannot be longer considered as true.

The fault condition is reported when DIG1 and DIG2 signals are not complementary for more than 100 ms.

REMOTE COMMUNICATION - the opto-insulated serial port RS485 can communicate with a personal computer or a remote control and monitoring system equipped with an RS485 interface or with a standard RS485/RS232 converter.

All the set-up and measured parameters can be transmitted on the RS485 communication serial port; when communication is active (LED REMOTE glows), the operator on front panel can view the relay set-up but changes of parameters are disabled (ENTER and  buttons disabled).

2 FRONT PANEL KEYS

The 5 push-buttons on the front panel allow to visualize all the protection parameters and to modify the protection set-up.



right arrow



down arrow



programming session activation or parameter confirmation



change or increment of the selected parameter



reset of the protection relay (ref. par. 4.3)

VISUALIZATION OF PARAMETERS

- all visualizations are circular and they can be displayed using the two arrow push-buttons.
- the structure of the visualizations and their contents are showed in Figures 1, 2, and 3.
- when the sealable transparent front panel is installed only the arrow push-buttons and the RESET push-button are accessible to prevent unauthorized modification of the protection set-up.

MODIFICATION OF PARAMETERS

- remove the transparent sealable front panel to access ENTER and  push-buttons.

3 FRONT PANEL LED SIGNALINGS

POWER (green)	⊕ auxiliary supply available
FAIL (red)	⊕ fault condition detected by SELF-DIAGNOSIS software or by PILOT WIRE FAULT MONITORING function
REMOTE (red)	⊕ communication session active on RS485 port
I> (red)	⊕ trip condition on I> threshold
I>> I>>> (red)	⊕ trip condition on I>> or I>>> thresholds
Io (red)	⊕ trip condition on Io>, Io>>, Io>>> thresholds

The last trip condition (threshold indication) is also showed on front panel display; more information on trip condition are presented in the recorded EVENT (see par. 5.10).

4 PROGRAMMING AND TEST

The protection relay is easily programmable following the instructions in the next paragraphs:

- HOW TO PROGRAM THE PROTECTION RELAY
- HOW TO MODIFY A VISUALIZED PARAMETER

All parameters can be freely modified; the proper protection set-up as required by the plant management is submitted to the operator's judgment.

4.1 How to program the protection relay

The programmable parameters are showed in Figures 1, 2 and 3 at the following references:

B2 ÷ B7	relay address (RS485) and date/time
C1	relay function
D1 ÷ D5	nominal values, contrast etc
E1 ÷ E5	thresholds and time delays
F1 ÷ F7	output relays functions
G1 ÷ G3	digital input functions
R1 ÷ R12	partial trip counters reset

The programming sequence is the following:

- 1) **SELECT** the visualization (on display) of the parameter to be modified using the arrow push-buttons
- 2) **ACTIVATE the PARAMETER MODIFICATION** session depressing the [ENTER] push-button and modify the parameter value
- 3) **END** the parameter modification session depressing again the [ENTER] push-button
- 4) **REPEAT** the procedure from 1) to 3) for all the parameters required to obtain the new protection relay set-up
- 5) **CONFIRM** the new protection relay set-up at the visualization CONFIRM PROG? (Fig. 2, ref. H1) within 5 minutes depressing the push-buttons buttons [ENTER],  up to visualize **YES** and [ENTER] again to confirm.

NOTE: The protection relay continues to operate using the previous set-up until the new set-up is confirmed as at point 5) above; the visualization of the modified parameters before the new set-up confirmation is only temporary to allow an easy definition of the new protection set-up.

If the new set-up is not confirmed within 5 minutes from the last pressed push-button, the protection relay visualizes again the previous set-up (the parameters set-up that the protection relay is still using).

4.2 How to modify a visualized parameter

When the parameter to be modified is visualized on front panel display do the following sequence:

- 1) **PRESS [ENTER]** to activate the parameter modification session

If one or more parameters are modifiable, on the first of them will appear a blinking cursor.

If no parameters are modifiable, no blinking cursor will appear.

- 2) **MODIFY THE PARAMETER** pressing the arrow push-buttons and 



when two parameters are modifiable, the push-button allows to point-out the parameter to be modified (the selected parameter will blink)



when numerical parameters are pointed-out the push-button allows to select the digit to be modified



increasing of the parameter

a) the digits are increased by 1 unit

b) the other parameters are presented following the selection list

- 3) **PRESS [ENTER]** to end parameter modification session

The modification session is ended and the parameter stops to blink

NOTE: if a numerical parameter is selected out of the accepted range (as shown in Table A) when the push-button **[ENTER]** is pressed for few seconds an error message will be displayed as:

Data
Error

and the parameter will be displayed again with the former value.

4.3 Reset

When the push-button **[RESET]** is pressed, the protection relays returns to the standard condition:

- reset of glowing LEDs
- drop-off of tripped relays
- reset of any parameter changed but not confirmed (parameters are shown as confirmed at the end of the last programming session)

- display on STANDARD MODE (Fig. 1, ref. A1 - par. 5.1)

4.4 Test of output relays

When the output relays test is selected (Fig. 2, ref. F8) it is possible to command an output relay (one at the time) to trip from the current status allowing functional tests on electrical plants.

The output relays are activated with the following sequence:

- 1) **SELECT THE VISUALIZATION** of the desired output relay to be tested

TEST R1
OFF

- 2) **PRESS [ENTER]** to activate the test session; the message OFF will start to blink.
- 3) **PRESS** ; and the message on the display will change as:

TEST R1
ON

- 4) **PRESS [ENTER]** to command the instantaneous trip of the output relay (change of the current status).

The relay will stay on the new condition until:

- the  or [RESET] push-button is pressed
- the [ENTER] push-button is pressed and the sequence at points 3 and 4 is repeated (presenting OFF condition)

The same procedure will be used for R2, R3 and R4 relays.

5 DISPLAY AND PROGRAMMING

The contents and the structure of the displayed messages are shown in figures 1, 2 and 3; the references A1, B1, B2 etc. identify specific displayed messages in the figures.

5.1 Standard display

A1 - STANDARD DISPLAY

It is the standard displayed message without operator's intervention (no push-buttons pressed for at least 5 minutes) or when the RESET push-button has been pressed.

The displayed information is function of the protection relay status.

NORMAL FUCTIONING

During this state the following information can be visualized (as defined by set-up):

Protection function (ANSI code) - the display shows the ANSI codes of the selected functions (ref. C1 - FUNCTION SELECTION).

Measured current - the display shows one of the measured currents; the current to be visualized is selected by operator (ref. D4).

The current is visualized as primary value; if the selection of the current to be visualized refers to a current not measured (depending on FUCTION SELECTION) no values are presented.

ON TRIP CONDITION

When a trip condition occurs the protection relay visualizes the TRIP message that includes the threshold related to the trip; the displayed messages are as the following:

TRIP I>	TRIP Io>>	TRIP I>>>	TRIP Io>
------------	--------------	--------------	-------------

The information of the trip, as well the glowing of the related LEDs, is displayed until the [RESET] push-button is pressed.

If a new trip condition occurs, the displayed information will be updated; information related to previous trips are recorded in EVENTS memory.

FAULT CONDITION

When a permanent or temporary fault condition is detected by the self-diagnosis module, the following message is displayed:

FAIL eeeeeeee

The string eeeeeeee can be:

F.PILOT	Detected fault condition on pilot wire; the function related to DIG1 digital input is suspended Corrective action - verify pilot wire (short or open circuit)
---------	---

HARDWARE Detected fault condition on hardware or software resources of the protection relay; all functions are suspended.
Corrective action - replace the protection relay and contact SEB post sales service

5.2 Visualization structure

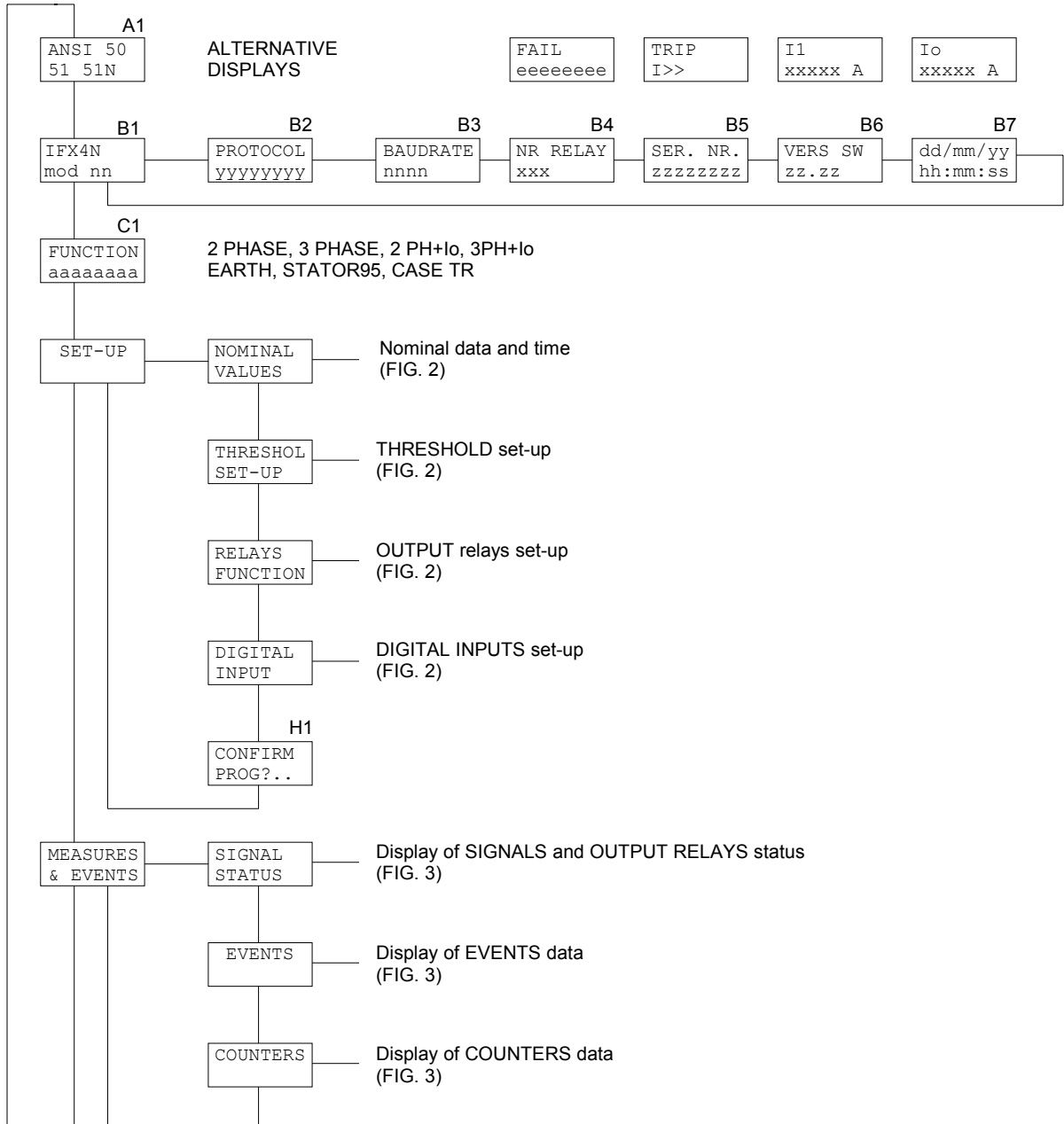

Figure 1

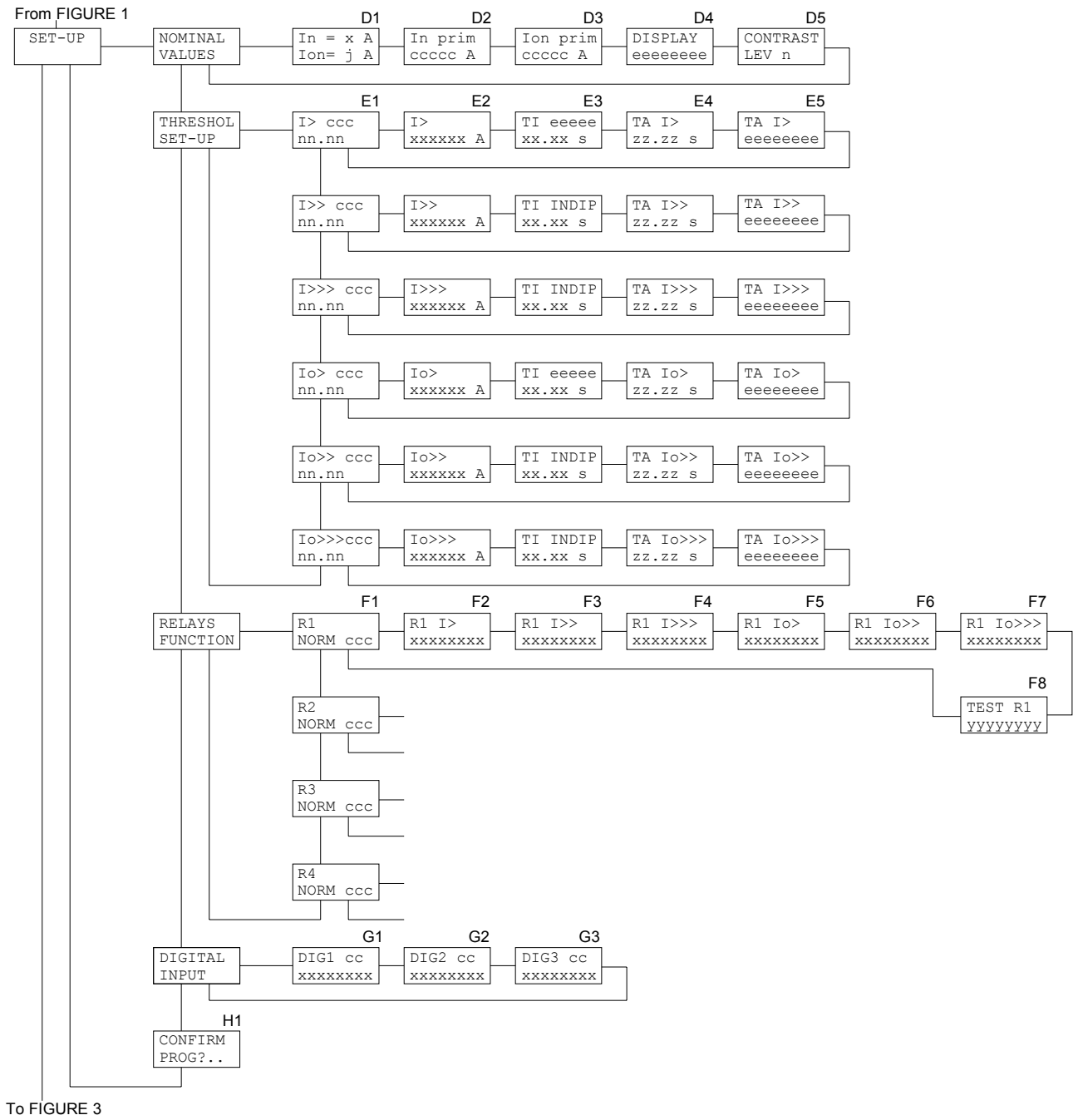

Figure 2

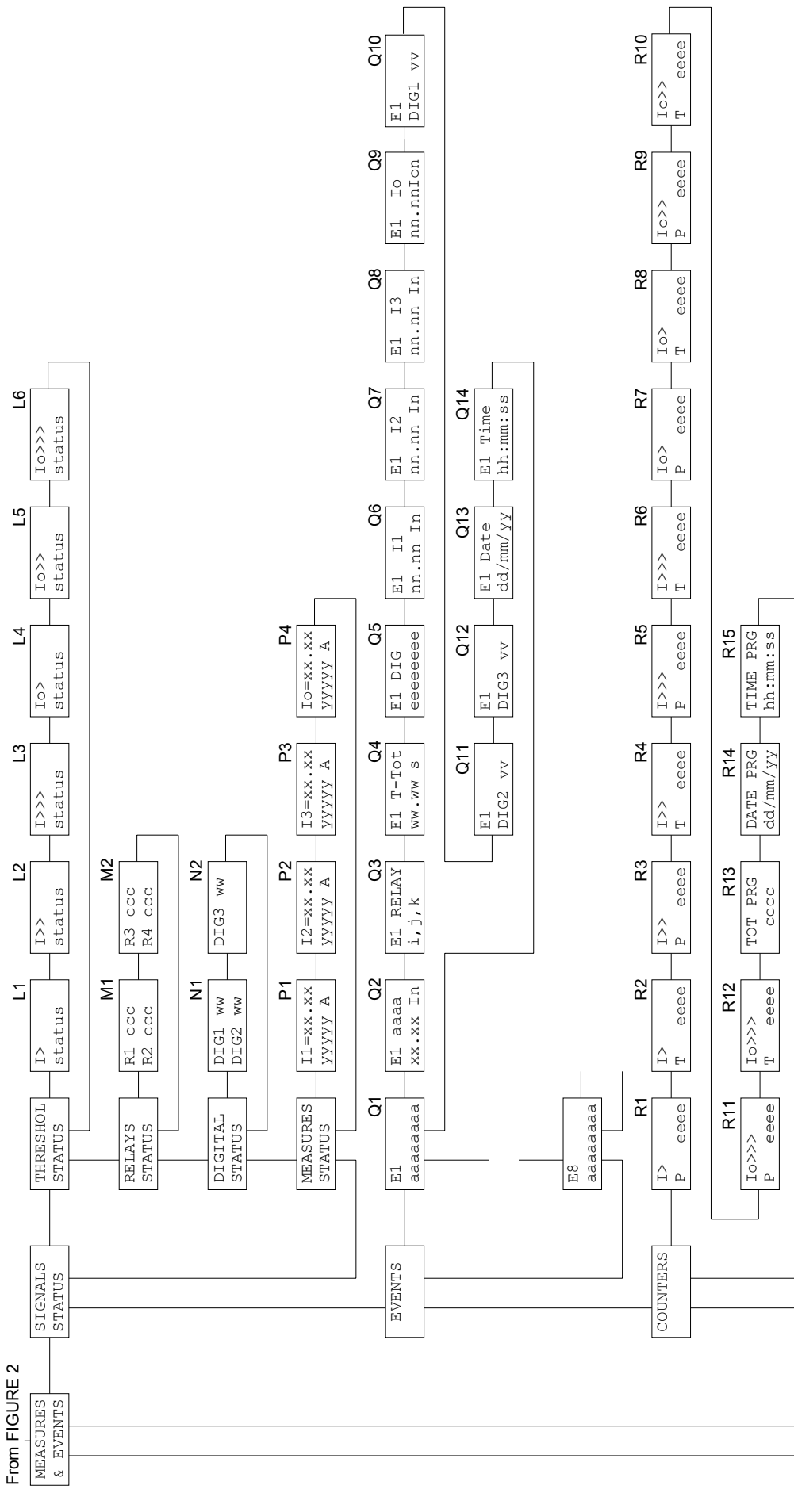

Figure 3

5.3 Address and Time (fig. 1)

B1 - RELAY MODEL (not programmable)

IFX4N mod. A5

Models: A5 (nominal earth fault current = 5A)
A1 (nominal earth fault current = 1A)

The nominal phase current is programmable 1 A or 5 A

B2 - COMMUNICATION PROTOCOL (programmable)

B2 PROTOCOL xxxxxxxx

The communication protocol is programmable between the followings:

STANDARD:	ASCII SEB protocol
MODBUS:	Modbus protocol (SLAVE)

When the MODBUS protocol is selected the following display is showed to allow the selection of the transmission speed:

B3 BAUDRATE xxxx

The xxxx parameter is selectable between the followings:

300 - 600 - 1200 - 2400 - 4800 - 9600

When the STANDARD protocol is selected the baud rate is automatically selected by the protection relay.

B4 - ADDRESS (programmable)

NR RELAY 001

Programmable address from 001 to 255.

The number is used on RS485 port to address a specific relay when two or more protection relays are linked on the same serial line.

B5 - RELAY SERIAL NUMBER (not programmable)

SER. NR 0012345

B6 - SOFTWARE REVISION LEVEL (not programmable)

SW REV
zz.zz

B7 - TIME/DATE (programmable)

dd/mm/yy
hh:mm:ss

Time and date are programmable and they are used to mark recorded events.

NOTE: the clock is not provided with back-up battery, therefore a loss of auxiliary supply will force time/date to the following condition:

01/01/90
00:00:00

5.4 Protection function selection (fig. 1)

C1 - FUNCTION SELECTION (programmable)

FUNCTION
xxxxxxxx

The selection of the active function defines the selectable thresholds.

FUNCTION	ANSI	SELECTION	ACTIVE THRESHOLDS
Two-phase overcurrent Three-phase overcurrent	50 51 50 51	2 Phase 3 Phase	> >> >>>
Two-phase + earth fault Three-phase + earth fault	50 51 51N 50 51 51N	2 Ph+Io 3 Ph+Io	> >> >>> Io> Io>> Io>>>
Earth fault (non-directional) Stator earth fault (95%) Transformer case earth-fault	51N 64S 64T	EARTH FT STATOR95 CASE TR	Io> Io>> Io>>>

Examples:

FUNCTION
2 PHASE

FUNCTION
3 PH+Io

FUNCTION
EARTH FT

5.5 Nominal values set-up (fig. 2)

D1 - NOMINAL CURRENT SELECTION In (programmable)

In = x A
Ion= 1 A

In = x A
Ion= 5 A

In nominal phase current programmable 1 A or 5 A
Ion nominal earth current (defined by models - manufacturer set-up)

I_{on} = 5 A: IFX4N model A5I_{on} = 1 A: IFX4N model A1**D2 - PRIMARY PHASE CURRENT (programmable)**

In prim
xxxxxx A

Primary phase current value of the installed phase CTs; the value is programmable from 0001 to 18500 A.

D3 - PRIMARY EARTH CURRENT (programmable)

I _{on} prim
xxxxxx A

Primary current value of the installed earth CT; the value is programmable from 0001 to 18500 A.

NOTE: when Holmgreen insertion is used, select **I_{on} prim = I_n prim**.

D4 - STANDARD DISPLAY SELECTION (programmable)

DISPLAY
eeeeeeee

It allows to select the standard displayed information (ref. A1) when no trip condition occurs and no fault condition have been detected by the self-diagnosis module; the available selections are the following:

ANSI	displays of ANSI code
I1	displays measured phase current I1
I2	displays measured phase current I2
I3	displays measured phase current I3
I _o	displays measured earth current I _o

The list of the selectable currents depends on the programmed FUNCTION SELECTION (ref. C1); the current is displayed in primary values (the value depends on D2 and D3 set-ups).

Selection examples:

DISPLAY
ANSI

DISPLAY
I1

DISPLAY
I _o

D5 - DISPLAY CONTRAST LEVEL (programmable)

CONTRAST
LEV x

The display contrast level is programmable from 0 to 9.

The backlighted display is switched off if no push-button is pressed for at least 5 minutes; when one of the front panel push- button is pressed the display is switched on.

5.6 Thresholds and time delays set-up (fig. 2)

In the programming session are displayed only the thresholds available depending on FUNCTION SELECTION set-up (ref. C1, paragraph 5.4).

The information and set-ups related to threshold I> in the following points (references E1÷E5) are effective for all the thresholds I>, I>>, lo>, lo>>, lo>>> just taking into consideration the change of the threshold identification (with limits as presented in table A).

E1 - THRESHOLD LEVEL SET-UP (programmable)

```
I>  ccc
nn.nn
```

I> threshold identification I>, I>>, I>>>, lo> etc.)

ccc ON - enabled threshold
OFF - disabled threshold (available but not active)

nn.nn threshold level expressed in terms of relative values

In (threshold I>, I>>, I>>>)
Ion (threshold lo>, lo>>, lo>>>)

Examples:

```
I>  ON
01.50
```

```
I>>> OFF
12.00
```

```
Io>> ON
05.00
```

E2 - THRESHOLD LEVEL IN PRIMARY VALUES (not programmable)

```
I>
xxxxxx A
```

The programmed threshold (ref. E1) is shown in terms of primary current; the value depends on the programmed CTs primary values (ref. D2 and D3 – paragraph 5.5).

I> threshold identification (I>, I>>, etc.)
xxxxxx: threshold level expressed in Amperes (primary values)

E3 - TIME DELAY SET-UP (programmable)

```
TI eeeee
xx.xx s
```

Set-up of time-delay to the activation (TRIP) of the programmed output relays when the measured current exceeds the threshold level.

Parameter TI eeeee: time delay characteristic

For I> and lo> thresholds, the time delay can be selected between one of the following:

INDIP	independent time delay
DIP=A	time delay as curve A IEC 255-4 (inverse time)
DIP=B	time delay as curve B IEC 255-4 (very inverse time)
DIP=C	time delay as curve C IEC 255-4 (extremely inverse time)

For the remaining thresholds the TI parameter is fixed as INDIP (independent time).

Parameter xx.xx:

Time independent - time delay (seconds) to activate the programmed output relays: the output relay trips when the measured current exceeds the threshold level for at least xx.xx seconds.

Time dependent - value of the parameter K (see formulas paragraph 7).

TI DIP=B 02.50 K	TI DIP=A 10.00 K	TI INDIP 03.25 s
---------------------	---------------------	---------------------

NOTE: the index K or s is shown coherently to the selected time-delay characteristic when the push-button ENTER is pressed.

E4 - ADDITIONAL TIME DELAY SET-UP (programmable)

The selection is displayed only when a TIME INDEPENDENT characteristic has been selected (TI INDIP at ref. E3); when TIME DEPENDENT characteristic has been programmed, the selection will not be displayed.

TA I> xx.xx s

The additional time delay TA is programmable from 00.00 to 99.99 seconds; please note that at least one of the digital inputs should be programmed to activate time delay function (ref. G1, G2, G3 – paragraph 5.8).

The additional time delay TA is added to the time delay TI to obtain the output relay trip when the TI+TA time expires.

The additional time delay TA will be added if the time delay TI is programmed at least equals to 50 ms (digital input acquisition time - 40 ms)

E5 - DIGITAL INPUT ACTIVE ON THRESHOLD (not programmable)

TA I> eeeeeeee

It shows the digital input programmed to activate the additional time delay TA on the displayed threshold.

The parameter eeeeeeee can show one of the following values:

DISABLED	none of the digital inputs has been programmed to activate an additional time delay related to threshold I>
DIG1	digital input DIG1 activates the TA delay on threshold I>
DIG2	digital input DIG2 activates the TA delay on threshold I>
DIG3	digital input DIG3 activates the TA delay on threshold I>

When a TIME DEPENDENT characteristic threshold has been programmed the visualization is omitted as no additional time delays can be defined and programmed on time dependent delays.

5.7 Output relays programming (fig. 2)

The session allows to program the activation of the output relays R1, R2, R3 or R4 on START or TRIP conditions for each threshold.

In the programming session are displayed only the thresholds available depending on FUNCTION SELECTION set-up (ref. C1 – paragraph 5.4).

Equivalent information and set-up related to relay R1 is available for the relays R2, R3 and R4 just changing the relay identification.

F1 - OUTPUT RELAY R1 QUIESCENT STATUS (programmable)

R1
NORM xxx

Programming of the R1 relay status when no START or TRIP conditions are activated (none of the measured currents exceed their thresholds).

NORM OFF: normally de-energized (energized status on activation)

NORM ON: normally energized (de-energized status on activation)

F2 - OUTPUT RELAY R1 ACTIVATION ON THRESHOLD I> STATUS (programmable)

R1	I>
xxxxxx	

Programming of the R1 output relay activation (START/TRIP/NONE) when one of the phase currents exceeds the programmed threshold I>.

The parameter **xxxxxx** is selectable as the following:

START	instantaneous output relay R1 activation when one of the measured phase currents exceeds the programmed threshold I>
TRIP	output relay R1 activation when one of the measured phase currents exceeds the programmed threshold level I> for at least TI or TI+TA seconds
NONE	no activation related to threshold I>

F3 ÷ F7 - OUTPUT RELAY ACTIVATION ON THRESHOLD I>>, I>>>, Io>, Io>> and Io>>> STATUS (programmable)

Example:

R1	I>>
xxxxxx	

R1	I>>>
xxxxxx	

R1	Io>
xxxxxx	

Programming of the output relay activation (STAR/TRIP/NONE) when one of the measured phase currents exceeds the thresholds I>> or I>>> and when the measured earth current exceeds the threshold Io>, Io>> or Io>>>.

F8 - TEST OF OUTPUT RELAY R1

TEST	R1
xxxxxxxxxx	

See paragraph 4.4

5.8 Digital inputs function programming (fig. 2)

For each digital input one of the following functions are selectable:

- additional time delay (related to one or more thresholds)
- ON / OFF threshold
- STATUS function (recording of measures on external command)
- pilot wire fault monitoring (only DIG2 monitors DIG1).

When function a) is programmed, a message is displayed at ref. E5, par. 5.6.

When the function of more than one digital input refers to a threshold, the priority will be the following:

- OF selection (threshold disabled) has the priority on TA function (additional time delay)
- the ALL selection (ALL the thresholds) has the priority on single threshold selection.

G1 - DIGITAL INPUT DIG1 SET-UP (programmable)

DIG1	cc
xxxxxxxxxx	

Programming of the function related to digital input channel 1 (DIG1).

Parameter **cc**: programming of the condition that activates the function related to digital input DIG1; the condition is selectable between HI and LO.

Parameter **xxxxxxxx**: programming of the function related to digital input DIG1; the following functions are selectable:

NONE	no functions active related to digital input DIG1
TA I>	additional time delay on threshold I>
TA I>>	additional time delay on threshold I>>
TA I>>>	additional time delay on threshold I>>>
TA lo>	additional time delay on threshold lo>
TA lo>>	additional time delay on threshold lo>>
TA lo>>>	additional time delay on threshold lo>>>
TA ALL	additional time delay on all thresholds
OF I>	threshold I> disabled
OF I>>	threshold I>> disabled
OF I>>>	threshold I>>> disabled
OF lo>	threshold lo> disabled
OF lo>>	threshold lo>> disabled
OF lo>>>	threshold lo>>> disabled
OF ALL	all thresholds disabled
STATUS	activation of status function (see paragraph 1.)

G2 - DIGITAL INPUT DIG2 SET-UP (programmable)

DIG2	cc
xxxxxxxx	

Programming of the function related to digital input channel 2 (DIG2); the selections available are the same as presented for DIG1 (ref. G1) plus the following:

MONITOR	activation of pilot wire monitor function.
---------	--

G3 - DIGITAL INPUT DIG3 SET-UP (programmable)

DIG3	cc
xxxxxxxx	

Programming of the function related to digital input channel 3 (DIG3); the selections available are the same as presented for DIG1 (ref. G1).

5.9 Parameter values visualization (fig. 3)

L1 - L2 - L3 - L4 - L5 - L6 - THRESHOLDS STATUS

The actual status of each threshold is displayed; only the thresholds available depending on FUNCTION SELECTION set-up are visualized (ref. paragraph 5.4).

For each threshold are displayed the threshold identification (I>, I>> etc.) and the threshold status; the status can show one of the following values:

ON	active threshold
OFF	disabled threshold (programmed OFF at ref. E1, par. 5.6)
OFF_DIG	threshold programmed active but momentary disabled by a digital input actual status.

Examples:

I>
ON

I>>>
OFF

I _o >
ON

I _o >>>
OFF DIG

M1 - M2 - OUTPUT RELAY STATUS

The actual status of each output relay is displayed; for each relay the following information is displayed:

relay identification (R1, R2, R3, R4)
 relay status (ON - activated, OFF - non activated)

Note that ON/OFF do not necessary mean energized or de-energized (see ref. F1).

N1 - N2 - DIGITAL INPUT STATUS

The actual status of each digital input is displayed.

For each digital input the following information is presented:

digital input identification (DIG1, DIG2, DIG3)
 digital input status (HI or LO)

P1 - P2 - P3 - P4 - MEASUREMENT DISPLAY

The actual value of the measured currents is displayed; only the measured currents (depending on FUNCTION SELECTION - ref. C1, paragraph 5.4) are displayed.

For each current the following information is displayed:

- current identification (I1, I2, I3, I_o)
- actual value expressed as I_n or I_{on}
- actual primary value expressed as Amperes

5.10 Events (fig. 3)

On the display are shown the memorized information related to the last 8 TRIP events.

The 8 events are recorded and identified with a progressive number from 1 to 8; the more recent event shows a lower number.

Q1 - EVENT NUMBER

E1
cccccccc

The index E1, E2 ... E8 identifies the memorized event.

The parameter ccccccc gives information on the kind of event and it can show one of the following values:

NONE	no event memorized
I>	event on trip threshold I>
I>>	event on trip threshold I>>

I>>>	event on trip threshold I>>>
lo>	event on trip threshold lo>
lo>>	event on trip threshold lo>>
lo>>>	event on trip threshold lo>>>
STATUS	information recorded on external command
POWER ON	switch-on of the protection relay (auxiliary power)

For the events NONE and POWER ON no other information is presented: for the other events the following displays give more detailed information on the event.

Q2 - TRIP THRESHOLD

```
E1    I>
xx.xx In
```

It shows the threshold related to the TRIP condition of the protection relay and the value of the threshold (in relative terms). The information is not shown on STATUS or POWER ON events.

Q3 - ACTIVATED OUTPUT RELAYS

```
E1 RELAY
nnnnnnnn
```

It shows the list of the output relay activated by the threshold trip.

Examples:

```
E1 RELAY
1, 3, 4
```

```
E3 RELAY
1, 4
```

When no output relays have been activated (no relays programmed to TRIP on the threshold) the following message will be displayed:

```
E1 RELAY
NONE
```

Q4 - TOTAL TIME DELAY ON TRIP

```
E1 T-Tot
www.ww s
```

It is shown the total delay to the TRIP of the output relays from the overcurrent detection; when additional delays are activated, the change of the status of the digital input that controls the additional delay during the delay itself could bring to a total time different from the sum of the programmed delays. If the total time is greater than 999 seconds the display of tenths is omitted.

When the event is memorized on external command (STATUS), the message N/A (Not Applicable) is shown instead of the number of seconds.

```
E1 T-Tot
N/A
```

Q5 - DIGITAL CHANNELS RELATED TO MEMORIZED EVENT

E1 DIG
1, 3

The list of the digital inputs related to the memorized event is displayed (STATUS function command or additional time TA enabled - ref. E4 par. 5.6).

If no digital inputs were activated, the message NONE is displayed.

Q6 - Q7 - Q8 - Q9 - MEMORIZED MEASURED CURRENTS ON EVENT

E1	I1
yy.yy	In

E1	I2
yy.yy	In

E1	I3
yy.yy	In

E1	Io
yy.yy	In

The values of the measured currents at the event are displayed; the values are expressed as In and Io terms.

There are presented only the currents measured coherently with the selection on FUNCTION SELECTION set-up (ref. C1 – paragraph 5.4).

Q10 - Q11 - Q12 - DIGITAL INPUTS STATUS ON EVENT

E1
DIG1 vv

E1
DIG2 vv

E1
DIG3 vv

The status of the digital inputs at the event are displayed.

The parameter **vv** can assume the value HI or LO.

Q13 - Q14 - DATE AND TIME OF THE EVENT

E1	Date
dd/mm/yy	

E1	Time
hh:mm:ss	

The date and time of the event are showed

5.11 TRIPS COUNTERS

In this section are displayed the total and partial counters of the output relay activation (on TRIP conditions) for each thresholds and the numbers of programming sessions with the date and time of the last confirmed programming session.

The total counters, the number of confirmed programming sessions and the date and time of the last confirmed programming session are not modifiable or resettable; the information related to the last programming session are used to control unauthorized access.

The partial counter can be modified following the standard set-up procedure for parameters as described at paragraph 4.2; the partial counters are immediately modified in the memory (the recorded values are immediately resetted without the need of the programming confirmation).

R1 ÷ R12 - TRIP COUNTERS

I>	
P	cccc

I>	
T	cccc

Display of the partial (P) and total (T) counters of the TRIP condition related to each threshold.

When the value exceed 9999 the counter starts again from 0000.

The counters are identified by the threshold name (I>, lo>, etc.); there are presented only the counters related to the active thresholds coherently with the selection on FUNCTION SELECTION set-up (ref. C1 – paragraph 5.4).

The partial counters are modifiable in the range from 0000 to 9999 following the standard set-up procedure (paragraph 4.2).

R13 ÷ R15 TOTAL PROGRAMMING SESSIONS AND DATE/TIME OF THE LAST PROGRAMMING SESSION

TOT PRG
eeee

DATE PRG
dd/mm/yy

TIME PRG
hh:mm:ss

Display of the number of confirmed programming sessions (from the factory set-up) and the date and time of the last confirmed programming session.

6 INSTALLATION

6.1 Supplied kit

RK VERSION - 19" rack installation (the proper rack is supplied by SEB)

- protection relay module IFX4N with rear socket
- transparent front panel for rack installation
- blister with items 1-2-3-4-5

CS VERSION - flush mounting installation

- protection relay module IFX4N with rear socket
- transparent front panel for rack flush mounting installation
- n° 2 brackets for flush mounting
- blister with items 1-2-3-4-5
- blister with item 6

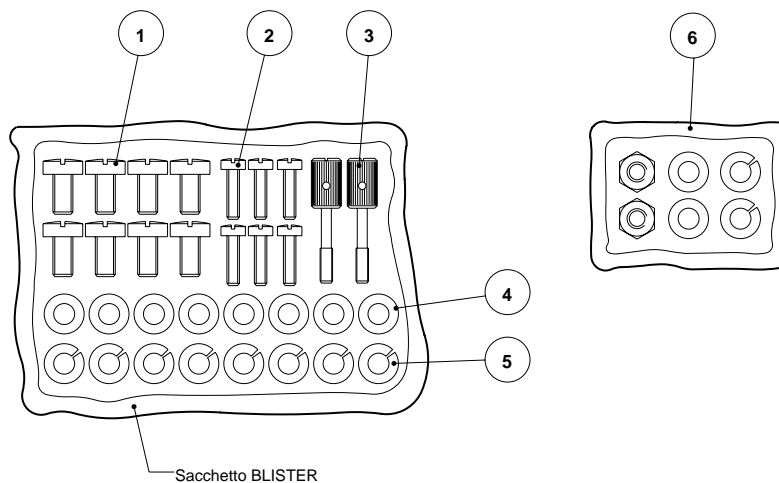

- 1) n° 8 screws to fix wire terminals of current circuits
- 2) n° 4 screws to fix the relay rear socket on the 19" rack (or on the two brackets for flush mounting) and n° 2 screws to fix (optionally) the protection relay on the front of the 19" rack
- 3) n° 2 knobs to fix the transparent front panel
- 4) n° 8 washers to be used to fix wire terminals (current)
- 5) n° 8 growers to be used to fix wire terminals (current)
- 6) small items to fix brackets on the cabinet (only CS version)

The knobs to fix the transparent front panel must be screwed through the panel the front panel itself; the operation will create a screw thread in the plastic material and the knobs will never be missed.

6.2 Cabling

Current circuits

It is suggested to terminate the current wirings using eyelet terminals.

Minimum suggested wire cross section: 2,5 mm²

With reference to the insertion diagram in the next page, the currents measured by the protection relay have the following matching:

I1	terminals A1 - A2
I2	terminals B1 - B2
I3	terminals C1 - C2
I ₀	terminals D1 - D2

For the functions as earth fault overcurrent , stator earth fault 95% (64S) and transformer case earth fault (64T) only the current I₀ is measured.

I ₀	terminals D1 - D2
----------------	-------------------

The terminal D1-D2 must to be connected to a CT sensible to earth currents (64S - on star connection of the generator, 64T on the earth connection of the transformer case).

Other circuits (output relays etc.)

It is suggested to terminate the current wiring using plug terminals.

Minimum suggested wire cross section: 1,5 mm²

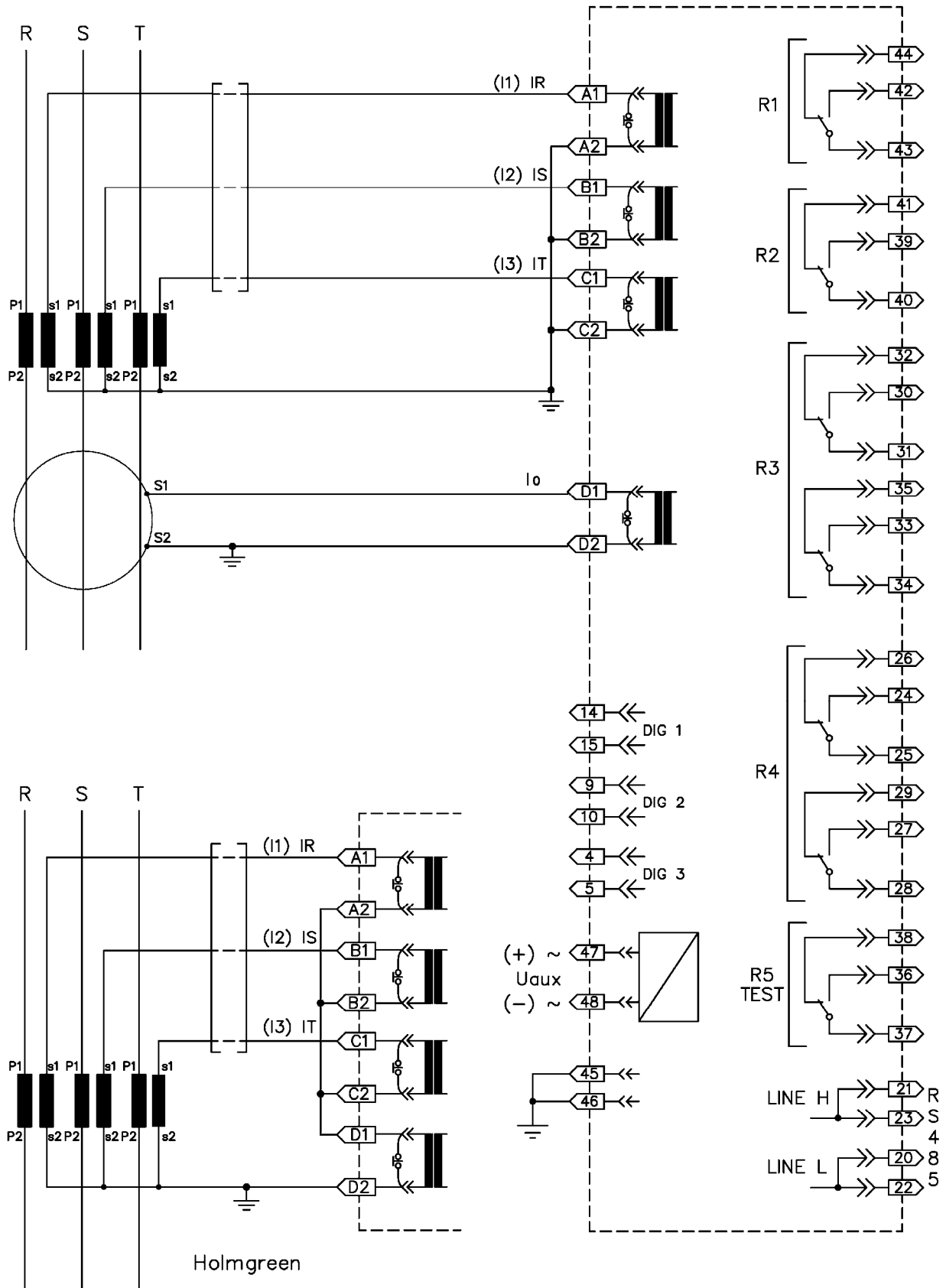

Insertion

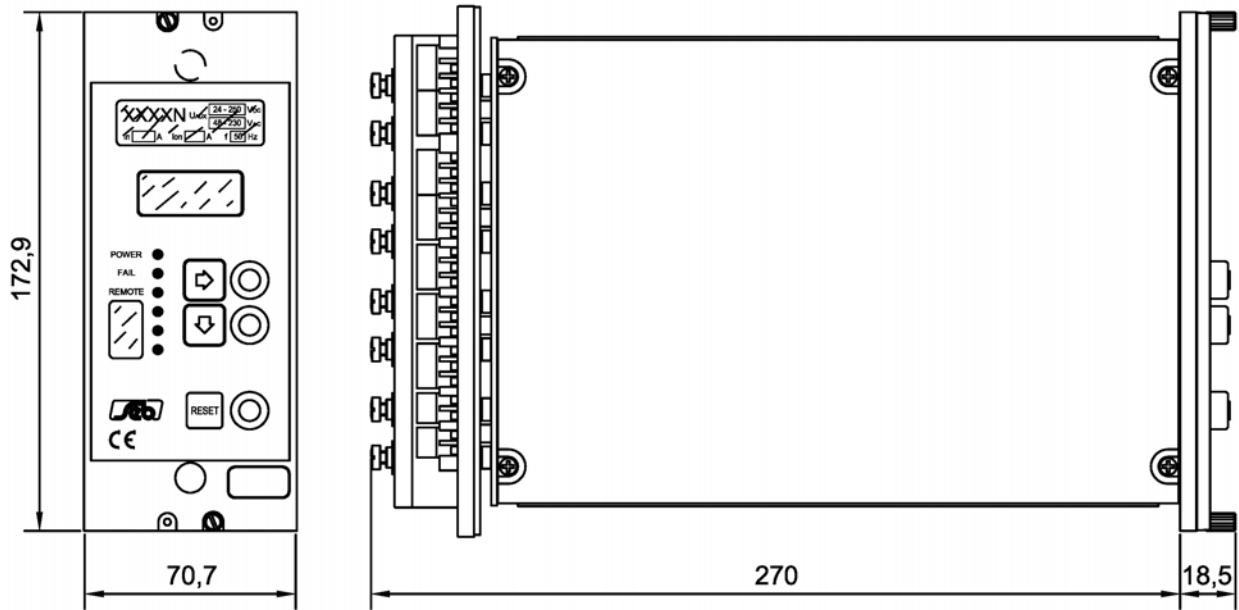

Dimensioni meccaniche
Case outlines

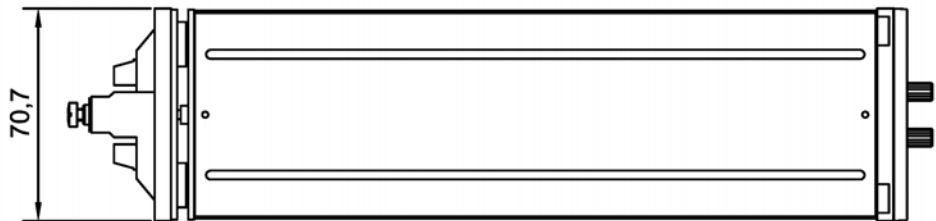

Dima montaggio da incasso
Flush mounting panel cut - out

Montaggio incassato / Flush mounting
Dimensioni pannello frontale trasparente :
Transparent front panel sizes :
208 x 89,5 mm.

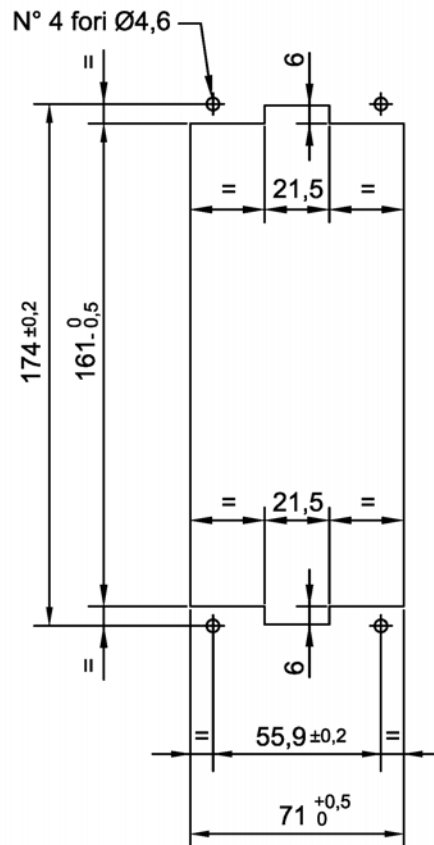

6.3 Relays R3 and R4 - Signaling / Command set-up

The protection relay is supplied with R3 and R4 relays configured as **SIGNALING RELAYS**, with 2 change-over output contacts with breaking capability equals to 0.2 A at 110 Vdc, L/R = 40 ms, 100000 operations.

Each R3 and R4 relay can be configured as **COMMAND RELAY** with 1 change-over output contact with breaking capability equals to 0.5 A at 110 Vdc, L/R = 40 ms, 100000 operations.

The new configuration is obtained with the following cabling:



6.4 RS485 serial communication port

The digital protection relay IFX4N presents an insulated serial interface RS485 half-duplex that allow the multi-drop connection up to 31 protection units.

When the STANDARD Seb communication protocol is selected, the transmission speed is automatically selected between 300 to 9600 bauds and the protocol is ASCII-HEX; the documentation related to the protocol is freely available on request.

When the MODBUS communication protocol is selected, the transmission speed can be programmed between 300 to 9600 bauds (ref. B3, par. 5.3).

It is suggested to use a shielded twisted pair AWG22; terminal 19 (not connected internally) can be used for shields connections.

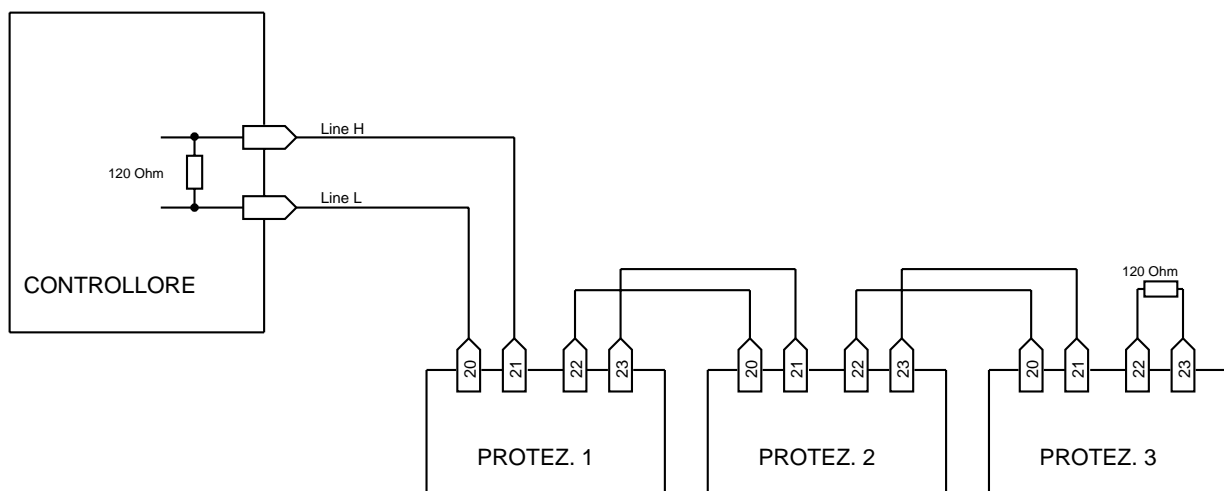

It is suggested to terminate the serial line with a resistance 120 Ω, 1/4 W.

7 TIME DEPENDENT CURVES

Curva - Curve A

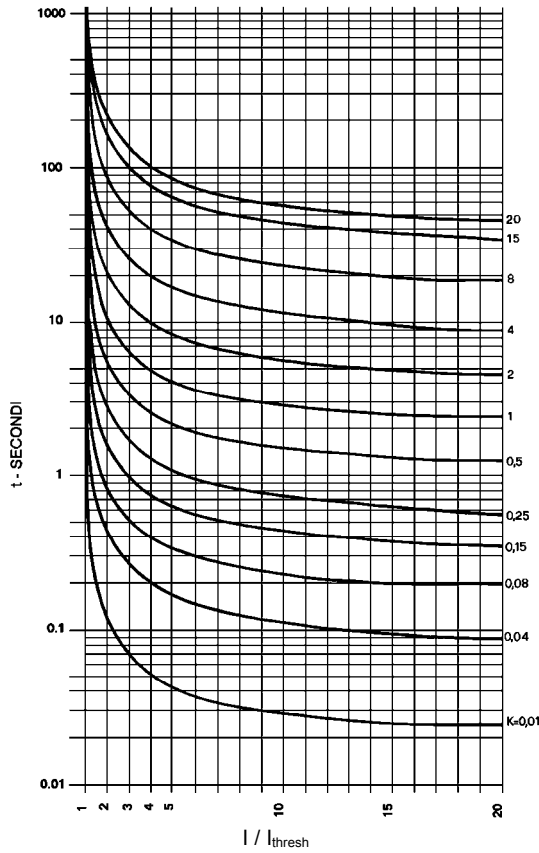

Curva - Curve B

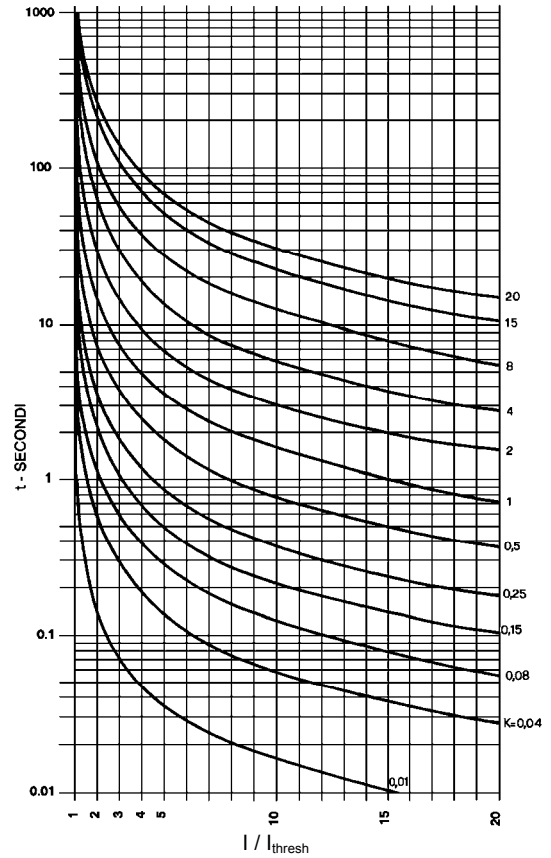

Curva - Curve C

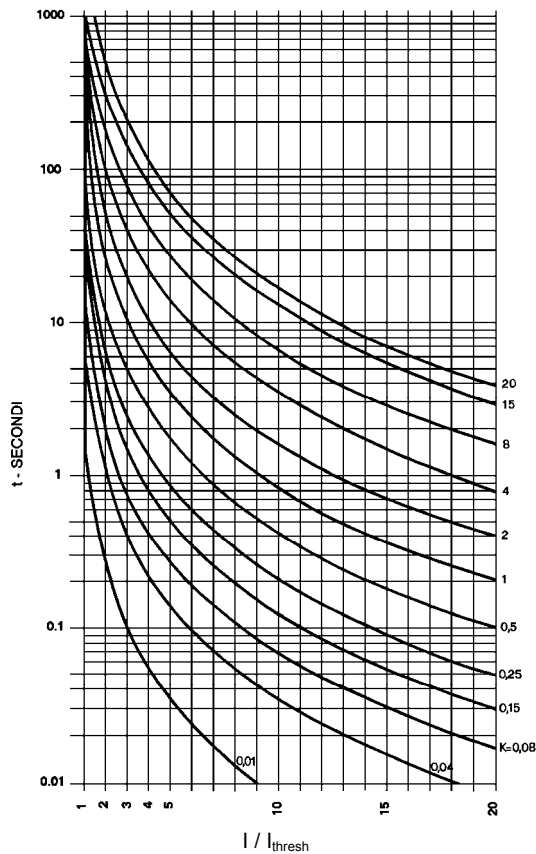

Time dependent characteristic

$$t = \frac{K_i * K}{\left(\frac{I}{I_{thresh}}\right)^\alpha - 1} + 0.02s$$

Curve IEC 255-4	A	B	C
K _i	0.14	13.5	80
α	0.02	1	2
K	Parameter 0.01 ÷ 20.00 s		
I / I _{thresh}	Ratio between the greatest measured current and the threshold I > or I _o >		

8 TECHNICAL CHARACTERISTICS

Measuring inputs

Rated phase current (In)	1 A / 5 A programmable
Rated earth current (Ion)	1 A o 5 A
Thermal withstand continuously	4 In / Ion
Thermal withstand for 1 s	100 In / Ion
Rated frequency	50 / 60 Hz
Primary CT's current	1 ÷ 18500 A

Output contacts ratings

Number of relays (note 1)	4 + 1
Rated current	5 A
Rated voltage	250 V
Contact configuration	change over
Breaking capability (note 2)	
- tripping relays (R1, R2)	0.5 A
- signaling relays (R3, R4, R5) (note 3)	0.2 A
Mechanical life	> 10 ⁶

Digital inputs

Number of inputs	3
External control voltage	as Uaux
Typical current (sink)	2 mA

Data transmission

Standard	RS485 half duplex
Communication protocol	MOD-BUS ASCII
Transmission speed	300 - 9600 baud selectable
Optional	fibre optic module

Auxiliary supply

Range	24 ÷ 320 Vdc ± 20%
	48 ÷ 230 Vac ± 20%
Frequency (Vac)	47 ÷ 63 Hz
Burdens (min/max)	5 / 10 W

Environmental conditions

Operation	-10 / +60 °C
Transport and storage	-25 / +80 °C
Relative humidity (without condensation)	< 95%
Protection degree for flush mounting (optional)	IP 52 (IP 54)
Weight	2.5 kg

- Note 1) The additional relay R5 is controlled by self-test program
 Note 2) Breaking capability at 110 Vdc, L/R 40 ms, 100.000 operations
 Note 3) The output contacts of R3 and R4 relays can be configured as signaling or tripping relays

9 TABLES

Table A **Thresholds and time delays**

THRESHOLDS	I>	I>>, I>>>	Io>	Io>>, Io>>>
Setting	0.10 ÷ 5.00 In / OFF	0.10 ÷ 40.00 In / OFF	0.005 ÷ 2.00 Ion ¹ / OFF	0.10 ÷ 10.00 Ion / OFF
Resolution	0.01 In	0.01 In	0.005 Ion ²	0.01 Ion
TIME DELAYS				
Definite Time Setting	0.02 ÷ 99.99 s	0.02 ÷ 99.99 s	0.02 ÷ 99.99 s	0.02 ÷ 99.99 s
Resolution	0.01 s	0.01 s	0.01 s	0.01 s
Dependent time				
Characteristic curves (IEC-255)	A, B, C	--	A, B, C	--
Characteristic constant	0.01 ÷ 20.00 s	--	0.01 ÷ 20.00 s	--
Resolution	0.01 s		0.01 s	
Additional delay	0.00 ÷ 99.99 s	0.00 ÷ 99.99 s	0.00 ÷ 99.99 s	0.00 ÷ 99.99 s
OTHER VALUES				
Burden referred to rated value	0.3 VA / phase		0.3 VA / phase	
Drop-off ratio	≥ 0.95			
Overshoot time	≤ 30 ms			
Output relays R1, R2, R3, R4	Programmable for each threshold START / TRIP and normally ON / OFF			

¹ Minimum threshold value 0.005 Ion is available starting with firmware version 2.32; with firmware version until 2.31, minimum threshold value was 0.01 Ion

² Resolution 0.005 Ion is available starting with firmware version 2.31; with firmware version until 2.30, resolution was 0.01 Ion

SEB DIVISIONE ELETTRONICA E SISTEMI - UFFICIO COMMERCIALE
Via Segantini, 5 - 20825 BARLASSINA (MB) - **tel.** +39 0362 5669.1 - **fax** +39 0362 556622
web: www.seb-barlassina.it
mail to: servizio-clienti@seb-barlassina.it