



EtherControl ®

User Manual

EtherControl Controlled Node – Binary Input/Output EBIO

SHF Communication Technologies AG
Division Automation

September 2006, Preliminary

Content:

1.	General information	3
1.1.	Copyright	3
1.2.	Intended use	3
1.3.	Symbols / Abbreviations	3
2.	System description	3
2.1.	Ethernet Powerlink Networks	3
2.2.	Controlled Node – EtherControl	5
2.3.	Construction	5
2.4.	Processor unit	5
2.5.	Periphery unit	5
3.	Technical data	6
3.1.	Mechanical parameters	6
3.1.1.	General information	6
3.1.2.	Distance to the casing wall	6
3.1.3.	Environmental Specification	6
3.1.4.	Storage and transportation conditions	7
3.1.5.	Connectors	7
3.2.	Electrical parameters	7
3.2.1.	Supply of the module	7
3.2.2.	Protection	7
3.2.3.	Ethernet connection	8
3.2.4.	Binary inputs	8
3.2.5.	Binary outputs	9
4.	Installation	10
4.1.	Mechanical setup	10
4.2.	Electrical installation	10
4.2.1.	Connection of terminals A – D	10
4.2.2.	Connection of power supply	11
4.2.3.	Ethernet connectors	11
5.	Controls	11
5.1.	Indicators	11
5.1.1.	Display	11
5.1.2.	Status indicators	12
5.1.2.1.	Error LED	12
5.1.2.2.	STATUS LED	12
5.2.	User elements	12
5.2.1.	Address switches	12
5.2.2.	Control keys	12
5.2.3.	Contrast level	13
6.	Technical description	13
6.1.	Module EBIO	13
7.	Menu selection	14
7.1.	Main menu	14
7.2.	Input/Output simulation	15
7.3.	Changing of the IP address	15
7.4.	Specification of module and Powerlink data	16
7.5.	Simulation enable	17
8.	Object dictionary	17
8.1.	Process data objects (PDO), Service data objects (SDO) and module parameters	17
8.2.	PDO Mapping	18
8.3.	NMT general objects	18
8.4.	Timing objects	20
8.5.	Error signalling and handling	20
8.6.	Communication interface description error	22
8.7.	Others	22
9.	Accessories	23
9.1.	2-pin plug for the connection of voltage supply	23
9.2.	9-pin plug for the connection of the periphery (I/O connection)	23
9.3.	Ethernet cable	23

1. General information

1.1. Copyright

This manual and the illustrations contained herein are provided by SHF AG and are copyright protected. Any reproduction, modification or translation into other languages without permission is an offence against copyrights and is forbidden. Violations will lead to compensation claims by SHF AG. (copyright according to DIN 34)

1.2. Intended use

The devices are to be mounted and used only for the intended application. No express warranties and no implied warranties whether of merchantability or fitness for any particular use, or otherwise, other than those expressly set forth herein which are made expressly in lieu of all other warranties. Any usage or connection not described in this manual has to be coordinated with SHF AG and requires a written confirmation.

Deviations between the product and the manual are possible. Make sure the version of the device is corresponding to the manual. Modifications without essential technical changes do not require any change in the manual.

1.3. Symbols / Abbreviations

EPL	–	Ethernet Powerlink
BIO	–	Binary input and output
MN	–	Managing Node
CN	–	Controlled Node
H x W x D	–	Height x Width x Depth
SpV	–	Power supply input
GND	–	Ground
STP	–	Shielded twisted pair
Hex	–	Hexadecimal

2. System description

2.1. Ethernet Powerlink Networks

The physical base of the Ethernet Powerlink protocol is the normal Fast Ethernet 100Base-TX network. The difference of the Powerlink protocol is the combination of asynchronous and isochronous parts in a cycle.

In the case of real time requirements in this real time part of the network, only Ethernet Powerlink units can be connected. To integrate other standard Ethernet devices it has to be used an Ethernet to Ethernet Powerlink gateway.

The Ethernet Powerlink network requires one Managing Node (MN) to control the strictly deterministic data traffic. The cycle time is dependent on the number of the connected Controlled Nodes (CN) and the size of the asynchronous data part. With the smallest

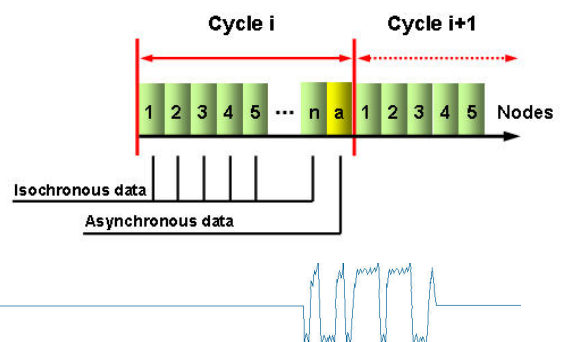

configuration (1 x MN and 1 x CN), a minimal cycle time of 200 μ s can be achieved. The accuracy of the cycles (Jitter) will generally be 1 μ s or lower.

By using the asynchronous protocol part, the CN can be IP addressed from each browser through the connection of the Managing Node with the standard Ethernet. In that way by the continuous network structure remote control independent from the Ethernet Powerlink Protocol is possible. Direct access to the individual network units, for example via internet, will be available up to the Ethernet Powerlink network.

If no real time functionality is required, the Ethernet Powerlink units can be used also in standard Ethernet networks.

The topology of the Ethernet Powerlink network is very flexible. Depending on the technical specification of the CN, standard Ethernet Hubs or Switches, a star or daisy-chain topology or a mixture of both will be possible.

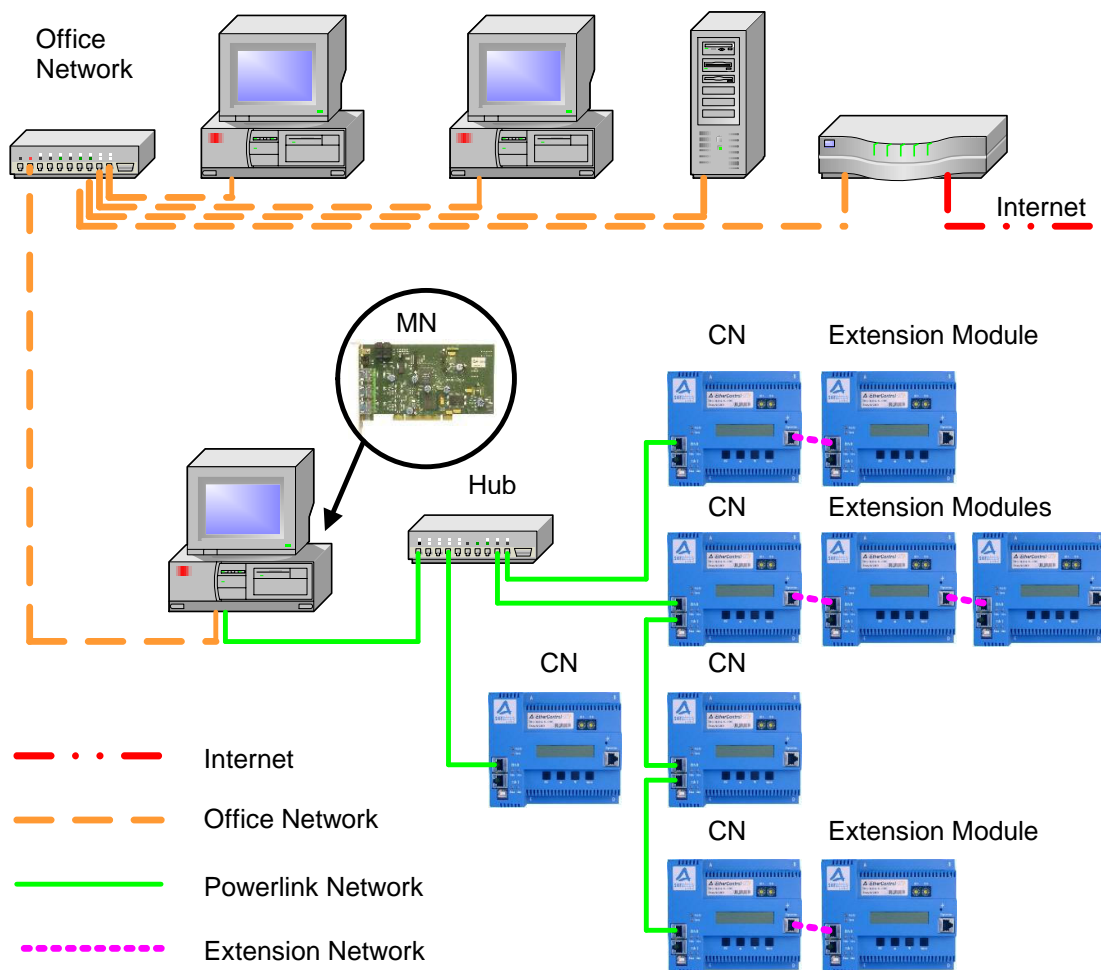

Example of an Ethernet Powerlink Network in connection to a super ordinate Ethernet Network.

2.2. Controlled Node – EtherControl

The EtherControl module is a compact input and output device with own controller and storage area, as well as an Ethernet network connection. It consists of a processor and a peripheral unit. The module contains an integrated Hub. So it will be possible to create a daisy-chain topology without additional devices.

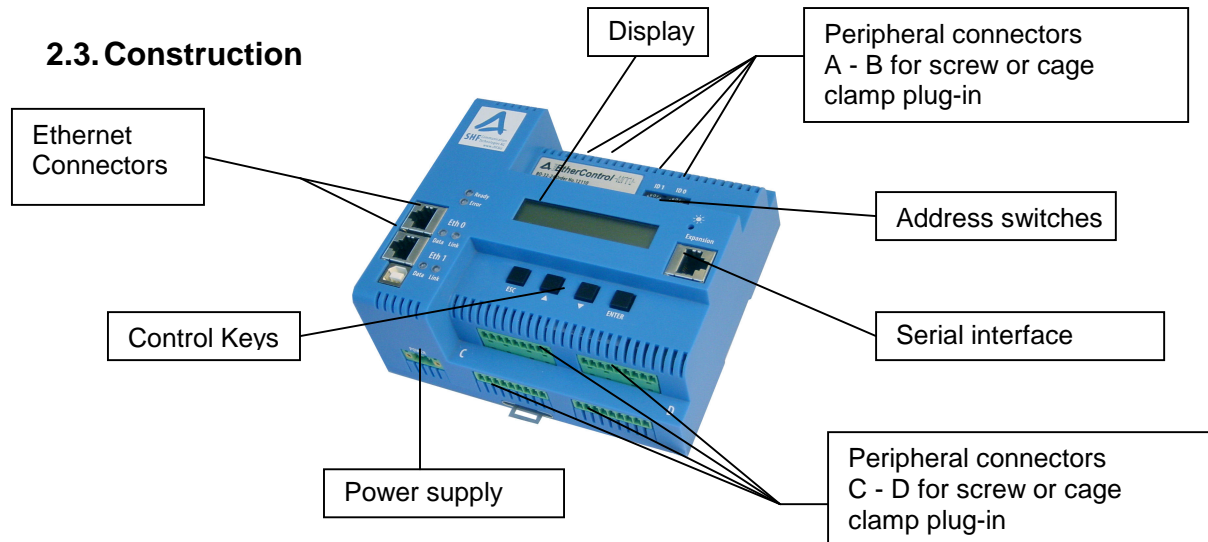

Construction of the EtherControl Module

2.4. Processor unit

The processor unit of the EtherControl modules realises the I/O control, network connections, control of the display and the keys and running customised applications like compact PLC and data storage functions.

On delivery the module is loaded with a basic program, running standard functions.

The display shows basic information of the module as well as information about the inputs and outputs. The keys are used for navigation through the menu. Keys and display can be used also by customised software.

On the module sockets for the network connection are present. Other hardware connections can be used with adapters connected to the RJ45 sockets.

2.5. Periphery unit

The peripheral unit realises the connection to the process periphery. The module has 8 connectors with 9 pins. As standard applications are offered defined combinations of different binary and analogue inputs and outputs and in addition customized combinations are possible.

3. Technical data

3.1. Mechanical parameters

3.1.1. General information

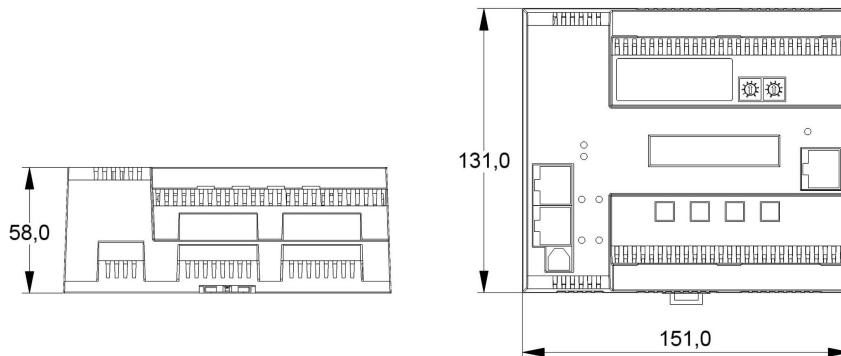

Dimensions H x W x D	131 x 151 x 58 mm
Housing material	ABS
Mounting	Clip mounting on DIN Rail
Installation orientation	Vertically or horizontally
Weight	approx. 465 g without extension options

3.1.2. Distance to the casing wall

Right / Left	0 mm
Top / Bottom	20 mm
Front panel	40 mm

Attention:

The distance between the I/O modules and the casing walls must be kept to ensure sufficient ventilation.

3.1.3. Environmental Specification

Ambient operating temperature	0 °C ... 50 °C (optionally -20 °C ... +70 °C)
Relative humidity	5 ... 95 %, non condensing
Operating atmospheric pressure	86 ... 108 hPa
Pollution resistance	Test according IEC 60068-2-42 und IEC 60068-2-43
Vibrations	according IEC 60068-2-6
Shocks	according IEC 60068-2-27
Special conditions	Additional measures have to be taken in the following environments: – dust, corrosive steams or gas – ionising radiation The product must not be used: – in medical applications – in life-supporting systems

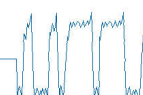

3.1.4. Storage and transportation conditions

Temperature	-20 °C ... +70 °C (optional -30 °C ... +80 °C)
Relative humidity	5 ... 95 %, non condensing
Atmospheric pressure	66 ... 108 hPa

3.1.5. Connectors

Power supply	2-pin plug – Screw- or cage clamp plug-in pluggable for wires up to 2,5 mm ²
I/O plugs	9-pin plug – Screw- or cage clamp plug-in pluggable for wires up to 2,5 mm ²
Ethernet connections	RJ45 plug
Extension connections	RJ45 plug

3.2. Electrical parameters

3.2.1. Supply of the module

Power supply	nominal 24V (range 9-60V DC)
Supply current (standard system)	< 200 mA at 24 V DC (Modul without load)
Power consumption	Max. 12 W

3.2.2. Protection

Protection class according EN 60 529	IP 20
Conformation	CE
Reverse voltage protection	Yes
Air/surface leakage distance	According EN 61131-2 and EN 50178 between circuits and parts and isolated circuits, according overvoltage category II, degree of pollution 2
Isolation	Yes, between digital part and inputs and outputs Test voltage DC 500 V
Electromagnetic emission	Radiated and conducted according EN 55011

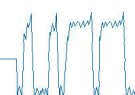

3.2.3. Ethernet connection

Transmission hardware	CAT5 STP or better
Transmission rate	10/100 Base-TX, 10/100 MBit
Interface connection	RJ45 plug

The three Ethernet connections are standard 10/100Base-TX interfaces for CAT5 or better twisted pair cables. Shielded twisted pair (STP) cabling is highly recommended.

The Ethernet Powerlink specification requires use of cross-over cables but in addition standard patch cables can be used with the MN because of the build-in auto-detection of cable type.

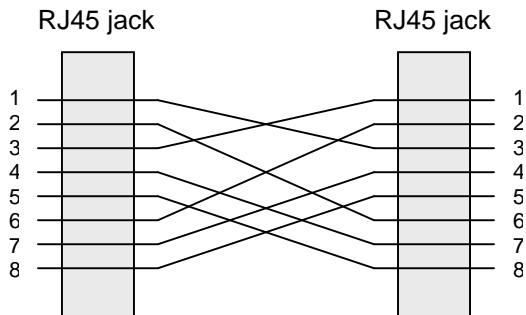

Recommended Pin Assignment according Ethernet Powerlink specification

3.2.4. Binary inputs

Input voltage	typical 24 V (range 12-60 V DC)
Input current	approx. 2,5 mA
Input frequency	≤ 5 kHz
Input delay	50 μ s – 4 ms (adjustable)
Connection	2-wire connection
Number of inputs	16
Isolation	All inputs separated from each other and from the digital part

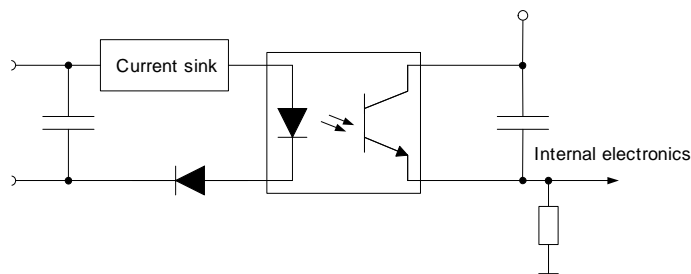

Binary Input schematic

3.2.5. Binary outputs

Output voltage	typical 24V (optionally 12-42V)
Output current	≤ 500 mA short-circuit proof
Output frequency	≤ 2 kHz
Output delay	100 μs ± 50 %
Feedback	Short circuit and external power detection
Connection	2-wire connection with separate ground clip - separate output power supply together for each output group
Number of outputs	16 (2 groups over 8 outputs)
Isolation	Outputs groups separated from each other and from the digital part

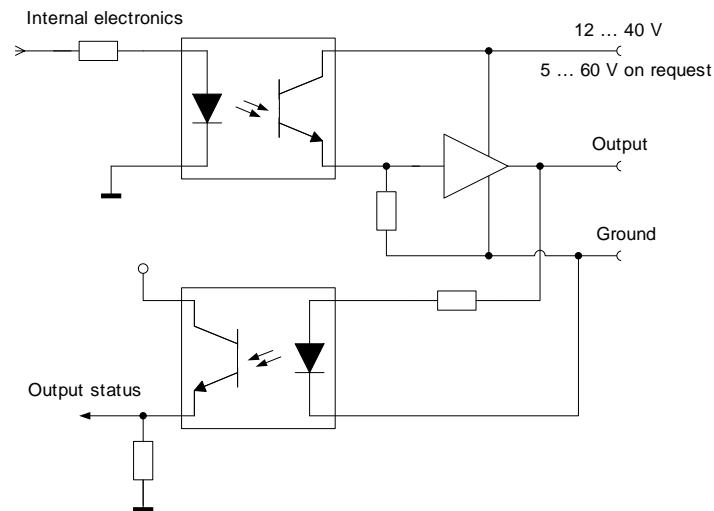

Binary output schematic

4. Installation

4.1. Mechanical setup

- The modules can be snapped directly onto a carrier rail in accordance with the European standard EN 50022 (DIN 35).
- The spacing between adjacent components, cable conduits, casing and frame sides must be maintained for the complete field bus node according paragraph 3.1.3.
- For disassembly use a screw driver for pulling down the mounting part.

Assembly instructions:

Assembly

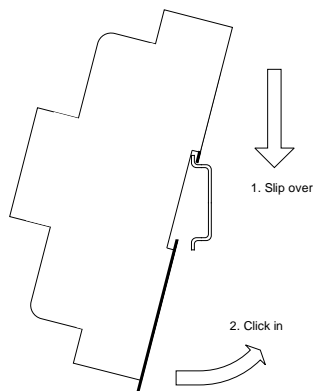

Disassembly

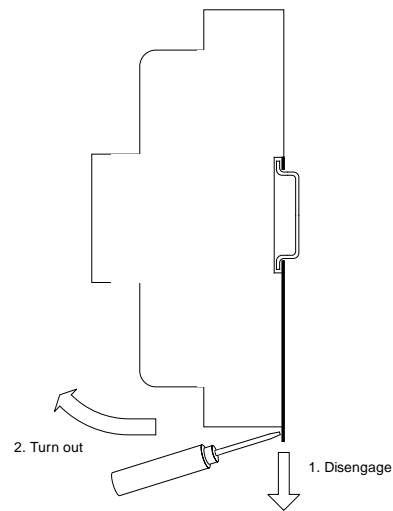

4.2. Electrical installation

4.2.1. Connection of terminals A – D

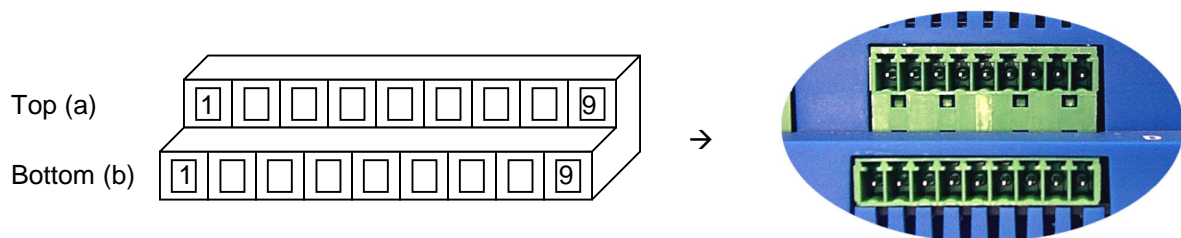

Connectors with nine contacts are used either with screw or cage clamp wire connection. Normally the modules are delivered with screw plug-in.

4.2.2. Connection of power supply

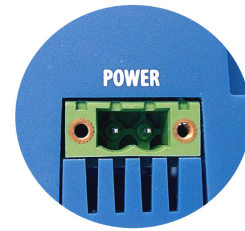
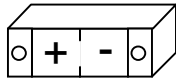

Power supply will be connected with a bipolar plug with either screw or cage clamp wire connection. The connector can be locked with two screws.

4.2.3. Ethernet connectors

In the modules there are two Ethernet sockets belonging to one Ethernet port. They are internally connected via a hub. The connection with the network is done with a RJ45 twisted pair connector.

The network connection has to be done on port Eth 0. The indicator "Link" lights on network link, the indicator "Data" flashes on data packets.

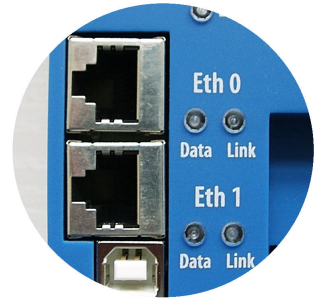

5. Controls

5.1. Indicators

5.1.1. Display

The modules have an alpha numerical display with two rows / sixteen columns. The display shows the actual process data as well as information's about the module itself and the communication status, e.g. errors.

The interaction with the module is done by menus shown on the display.

It is possible to write to the display within customer specific software.



5.1.2. Status indicators



5.1.2.1. Error LED

ERROR LED function is controlled by NMT State Machine transitions.

LED OFF	Power On, EPL cycles without errors (NMT_CT11)
LED ON	EPL cycles disturbed/aborted due to communication errors (NMT_CT3, CT6)

5.1.2.2. STATUS LED

STATUS LED (Ready) function is controlled by NMT State Machine states.

LED off	NMT_GS_OFF NMT_GS_INITIALISING, NMT_CS_NOT_ACTIVE
LED flickering	NMT_CS_BASIC_ETHERNET
LED single flash	NMT_CS_PRE_OPERATIONAL_1
LED double flash	NMT_CS_PRE_OPERATIONAL_2
LED triple flash	NMT_CS_READY_TO_OPERATE
LED on	NMT_CS_OPERATIONAL
LED blinking	NMT_CS_STOPPED

5.2. User elements

5.2.1. Address switches



The both Hex-switches control the last byte of the IP address. If the module communicates via the Powerlink protocol, this hex switch also determines the module address in the real time network.

5.2.2. Control keys

The keys are used to navigate through the build in menus. For the detailed explanation of the menus see module menu description.



5.2.3. Contrast level

The contrast of the display can be adjusted with a little screw driver.

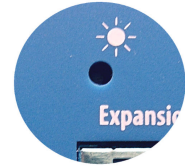

6. Technical description

6.1. Module EBIO

This module has 16 binary inputs and 16 binary outputs.

Maximum input voltage is defined in production.

Input voltage	5 V	10 V	12 V	24 V Standard	30 V	NAMUR
Switching threshold	2,5 V	5 V	6 V	12 V	15 V	according to standard

The supply voltage for the outputs is provided separately for the output blocks C – D via the clamp SpV.

Port configuration:

	A a (top)	A b (bottom)	B a (top)	B b (bottom)	C a (top)	C b (bottom)	D a (top)	D b (bottom)
1	–	–	–	–	SpV. C+	GND C	SpV. D+	GND D
2	BI1+	BI1-	BI9+	BI9-	BO1	GND C	BO9	GND D
3	BI2+	BI2-	BI10+	BI10-	BO2	GND C	BO10	GND D
4	BI3+	BI3-	BI11+	BI11-	BO3	GND C	BO11	GND D
5	BI4+	BI4-	BI12+	BI12-	BO4	GND C	BO12	GND D
6	BI5+	BI5-	BI13+	BI13-	BO5	GND C	BO13	GND D
7	BI6+	BI6-	BI14+	BI14-	BO6	GND C	BO14	GND D
8	BI7+	BI7-	BI15+	BI15-	BO7	GND C	BO15	GND D
9	BI8+	BI8-	BI16+	BI16-	BO8	GND C	BO16	GND D

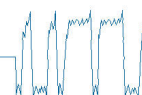

7. Menu selection

After power on the display will show the actual status of the inputs (top row) and outputs (bottom row) as standard display for instance

```
0010000100000000
01000000000000100
```

The selection can be made by the keys **ESC** , **▲** , **▼** and **ENTER**.

7.1. Main menu

With the arrow keys can be scrolled trough the menu and with the "ENTER" key the appropriate submenu can be selected.

A return to the standard display is made by the "ESC" key.

The following menu options can be selected from the main menu:

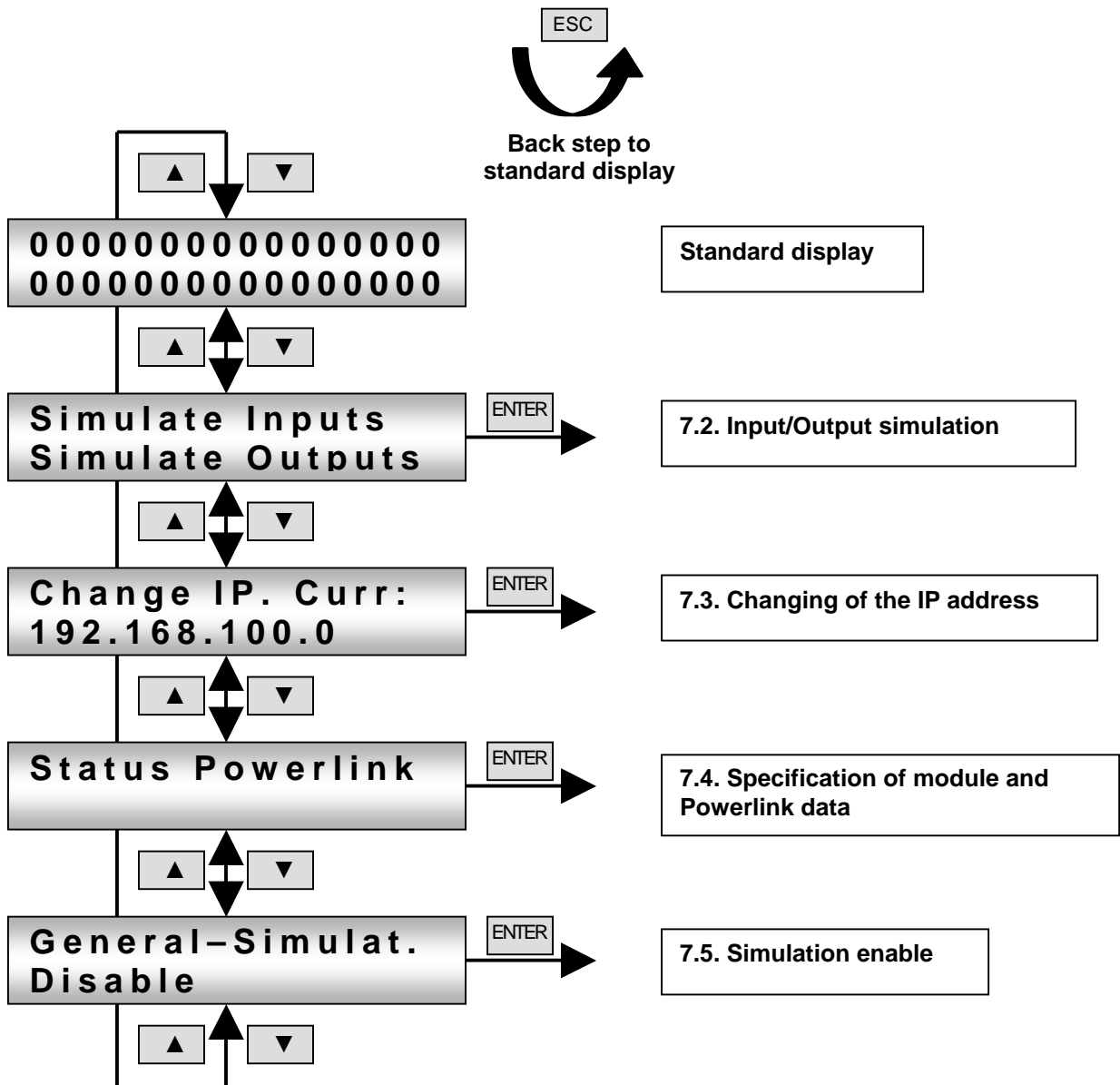

7.2. Input/Output simulation

In this menu the binary inputs and outputs can be pre set for simulation. Only after release under menu point 7.5., the simulation will be activated.

By operation of the arrow keys selected channel flashes in each case (blue figured) and can be changed over "ENTER". Simulated channels are inversely shown.

With the "ESC" key it is possible to return to the main menu. The simulated values are stored.

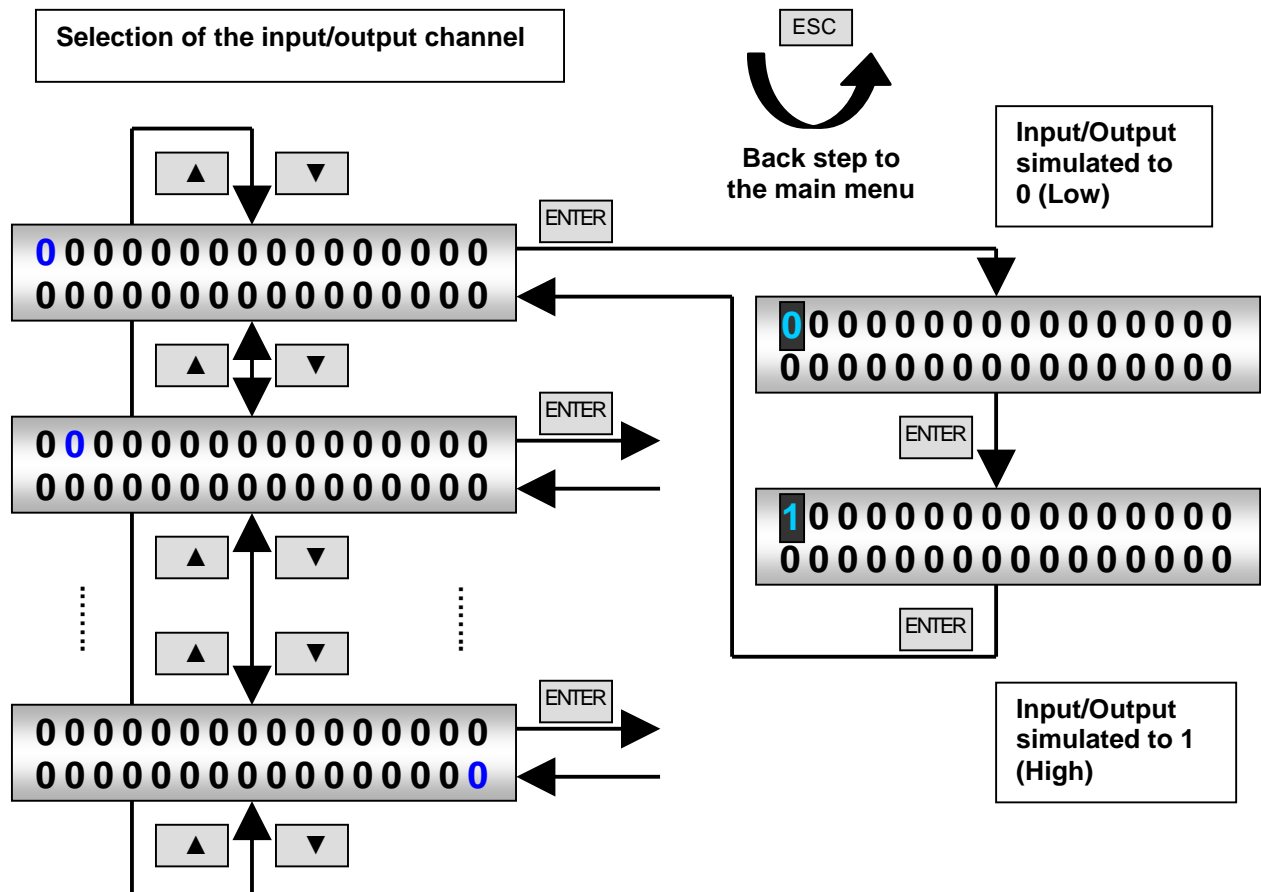

7.3. Changing of the IP address

The IP address for Ethernet Powerlink networks is fixed on 192.168.100.XXX. The differentiation of the CN is made by the lowest address byte. This address part is specified individually by the adjustment of the Address switches ID1 and ID2 for each module.

If the modules are used in other networks the three higher bytes can be adjusted by the menu option "Change IP...". The setting takes place byte by byte via increase or decrease of the address part value. By operation of the "ENTER" key selected channel flashes in each case (blue figured).

It is to be noted that without key actuation after 10 seconds the choose values are rejected. Pressing the "ESC" key within the 10 s the new address will be stored. Subsequently, a restart of the software of the module takes place.

If the lowest address byte was changed by the address switches, the new IP address will only be stored after the confirmation by pressing the "ESC" key and the following restart of the software.

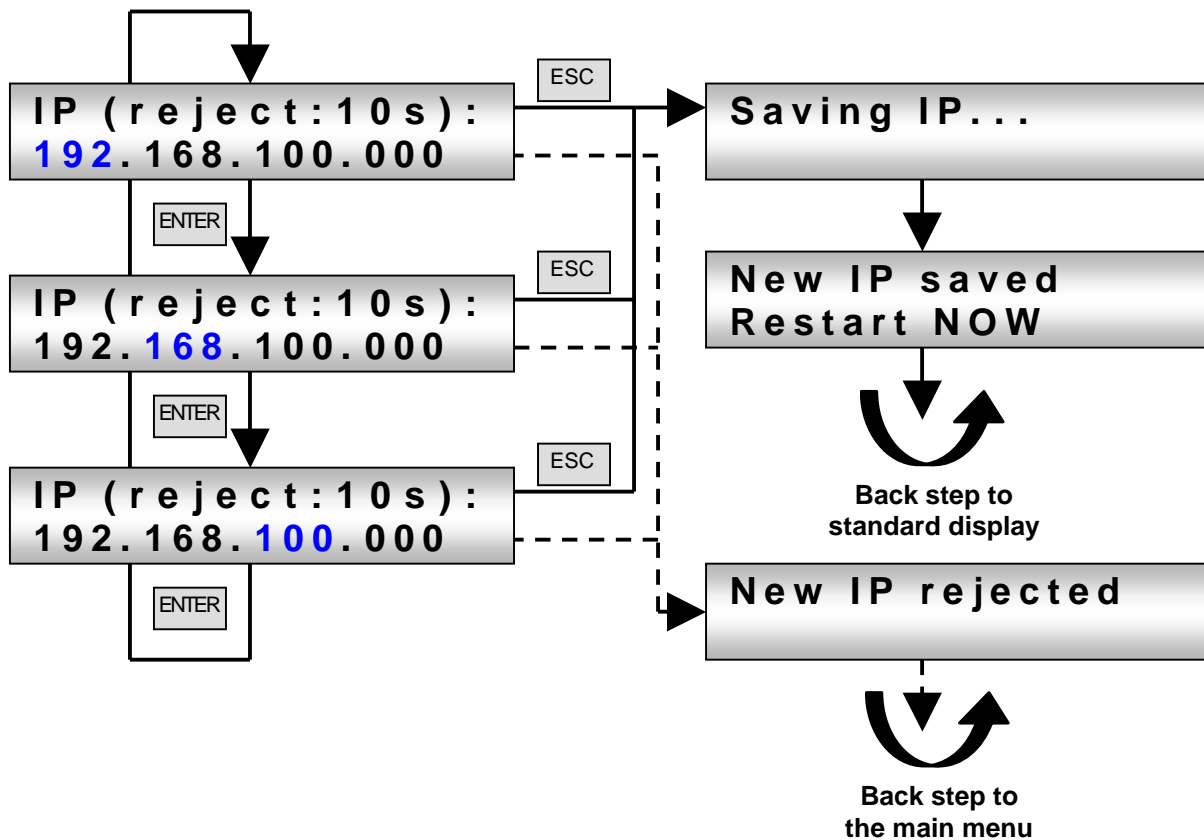

7.4. Specification of module and Powerlink data

Depending on the selection, the type of the module with the implemented software version or cycle and error of Ethernet Powerlink protocol will be displayed.

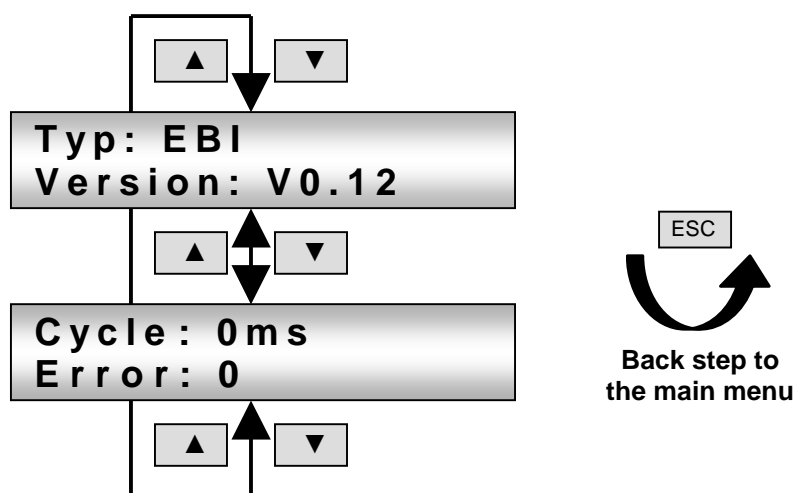

7.5. Simulation enable

This item in the main menu controls the simulation of all inputs. The simulation will be enabled or disabled by the "ENTER" key.

The main menu will not be left. With the arrow keys it can be scrolled further thru the main menu.

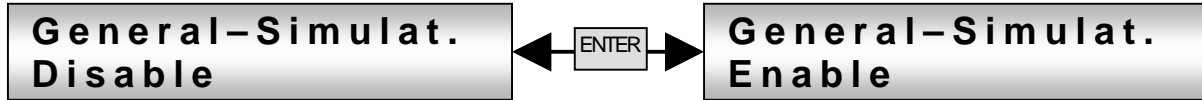

8. Object dictionary

The object dictionary of the CN is accessible by SDO communication via the MN.

Most objects are statically pre-defined by a configuration file stored on the CN. Objects can be changed dynamically by SDO communication from the MN or a modified file can be downloaded and the CN be restarted.

8.1. Process data objects (PDO), Service data objects (SDO) and module parameters

General List of PDOs and parameter objects addressable via SDO
– Standard Device Profiles:

Index	Sub-index	Size	Access	Default	Description
6000h					binary Inputs, Output readback 0= Off (0V), 1= On (24V)
	0	1	ro	4	number of entries
	1	1	ro	-	Input 0-7
	2	1	ro	-	Input 8-15
	3	1	ro	-	Output 0-7 readback
	4	1	ro	-	Output 8-15 readback

Index	Sub-index	Size	Access	Default	Description
6200h					binary Outputs 0= Off (0V), 1= On (24V)
	0	1	ro	2	number of entries
	1	1	rw	0	Output 0-7
	2	1	rw	0	Output 8-15

RPDO (Poll-Request):

Object Index	Sub-index	Value	Description
1400h			PDO_RxCommParam_00h_REC
	0	2	NumberOfEntries_U8
	1	0	NodeID_U8
	2	0	MappingVersion_U8

Object Index	Sub-index	Value	Description
1600h			PDO_RxMappParam_00h_AU64
	0	2	NumberOfEntries_U8
	1	0008_0000_00_01_6200h	Outputs 1-8
	2	0008_0008_00_02_6200h	Outputs 9-16

TPDO (Poll-Response):

Object Index	Sub-index	Value	Description
1800h			PDO_TxCommParam_00h_REC
	0	2	NumberOfEntries_U8
	1	0	NodeID_U8
	2	0	MappingVersion_U8

Object Index	Sub-index	Value	Description
1A00h			PDO_TxMappParam_00h_AU64
	0	4	NumberOfEntries_U8
	1	0008_0000_00_01_6000h	Inputs 1-8
	2	0008_0008_00_02_6000h	Inputs 9-16
	3	0008_0010_00_03_6000h	Output readback 1-8
	4	0008_0018_00_04_6000h	Output readback 9-16

8.2. PDO Mapping

Rx PDO mapping (Poll-Request-Frame):

Payload Offset	Object Index	Subindex	Size	Description
0	6200h	1	1	Outputs 1-8
1	6200h	2	1	Outputs 9-16

Tx PDO mapping (Poll-Response-Frame) :

Payload Offset	Object Index	Subindex	Size	Description
0	6000h	1	1	Inputs 1-8
1	6000h	2	1	Inputs 9-16
2	6000h	3	1	Output readback 1-8
3	6000h	4	1	Output readback 9-16

8.3. NMT general objects

Object Index 1000h: NMT_DeviceType_U32: 0003.0191h

D31-24	D23-20	D19	D18	D17	D16	D15-0
0	0	0 (Analogue Output)	0 (Analogue Input)	0 (Digital Output)	1 (Digital Input)	Device Profile Number 401d = 191h

Object Index 1008h: NMT_ManufactDevName_VS

Manufacturer Device Name: "SHF AG "

Object Index 1009h: NMT_ManufactHwVers_VS

Manufacturer Hardware Version: "0000"

Object Index 100Ah: NMT_ManufactSwVers_VS

Manufacturer Software Version: "ECIO V0.9a (EPL 0.94, 4NetOS 2.4)"

Object Index 1018h: NMT_IdentityObject_REC

Subindex	Access	Size	Value	Description
0	ro	1	4	Number of Entries
1	ro	4	0EACH	VendorId_U32
2	ro	4	12h	ProductCode_U32
3	ro	4	0	RevisionNumber_U32
4	ro	4	0	SerialNumber_U32

Object Index 1F82h: NMT_FeatureFlags_U32 (ro)

Bit	Value	Description
0	1	isochronous
1	0	SDO by UDP/IP
2	1	SDO by ASnd
3	0	SDO by PDO
4	0	NMT Info Services
5	0	Extended NMT State Commands
6	1	Dynamic PDO Mapping
7	0	NMT Service by UDP/IP
8-31	0	reserved

0= not supported, 1= feature supported

Object Index 1F83h: NMT_EPLVers_U8 (ro)

EPL Version 2.0: 20h

Object Index 1F8Ch: NMT_CurrNMTState_U8 (ro)

returns the current state of the NMT state machine

Object Index 1F9Eh: NMT_ResetCmd_U8 (rw)

This may be used to initiate a reset to the CN. The following values are valid:

Name	Value	Description
NMTInvalidService	FFh	returned when read
NMTResetNode	28h	Reset CN
NMTResetConfiguration	2Ah	Reconfigure CN
NMTResetCommunication	29h	Reset Communication

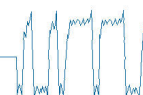

8.4. Timing objects

Object Index 1006h: NMT_CycleLen_U32

This value can be set to enable control of the cycle time by the CN. When the actual cycle time exceeds this value, the CN will signal an error.
The default value is 0 meaning cycle time check is disabled.

Object Index 1F98h: NMT_CycleTime_REC

Subindex 0: NumberOfEntries = 9
Subindex 1: IsochrTxMaxPayload_U16 (ro) = 4
Subindex 2: IsochrRxMaxPayload_U16 (ro) = 2
Subindex 3: PResMaxLatency_U32 (ro) = 200000
max. response time in ns to a PReq frame
Subindex 4: PReqActPayload_U16 (rw) = 2
Subindex 5: PResActPayload_U16 (rw) = 4
Subindex 6: ASndMaxLatency_U32 (ro) = 200000
max. response time in ns to a SoA frame
Subindex 7: MultipleCycleCnt_U8 (rw) = 0
number of multiplexed cycles (0=no multiplexed cycles)
Subindex 8: AsyncMTUSize_U16 (rw) = 282
max. asynchronous frame size for ASnd frames
Subindex 9: Prescaler_U16 (rw) = 2
toggle rate of the PS bit in SoC frames

8.5. Error signalling and handling

Object Index 1001h: ERR_ErrorRegister_U8

0= No Error
1= Error

Bit	Description
0	Generic Error
1	n/a, always 0
2	Supply Voltage failure
3	n/a, always 0
4	Communication Error
5	n/a, always 0
6	reserved, always 0
7	0

Object Index 1003h: ERR_History_ADOM

Subindex 0: num_entries_U8 (writing a '0' will clear the error history)
Subindex 1-254: HistoryEntry_DOM

Error Handling Objects:

The cumulative counters (...Cum_U32) are counting the total number of errors. The threshold counters (...Thr_U32) are incremented when an error occurs and decremented with each correct cycle indicating the relation between erroneous and correct cycles. The threshold value can be set to trigger an action when the threshold counter reaches this value.

Object Index	Sub-index	Size	Name/Description
1C0Ah			DLL_CNCollision_REC Monitors the Collision errors
	0	1	NumberOfEntries_U8 = 3
	1	4	DLL_CNCollisionCum_U32
	2	4	DLL_CNCollisionThr_U32
	3	4	DLL_CNCollisionThreshold_U32 When reached state is changed to NMT_GS_RESET_COMMUNICATION
1C0Bh			DLL_CNLossSoC_REC Monitors the Loss of SoC events
	0	1	NumberOfEntries_U8 = 3
	1	4	DLL_CNLossSoCCum_U32
	2	4	DLL_CNLossSoCThr_U32
	3	4	DLL_CNLossSoCThreshold_U32 When reached state is changed to NMT_CS_PRE_OPERATIONAL_1
1C0Ch			DLL_CNLossSoA_REC Monitors the Loss os SoA events
	0	1	NumberOfEntries_U8 = 3
	1	4	DLL_CNLossSoACum_U32
	2	4	DLL_CNLossSoAThr_U32
	3	4	DLL_CNLossSoAThreshold_U32 When reached state is changed to NMT_CS_PRE_OPERATIONAL_1
1C0Dh			DLL_CNLossPReq_REC Monitors the Loss of Poll-Request events
	0	1	NumberOfEntries_U8 = 3
	1	4	DLL_CNLossPReqCum_U32
	2	4	DLL_CNLossPReqThr_U32
	3	4	DLL_CNLossPReqThreshold_U32 When reached state is changed to NMT_CS_PRE_OPERATIONAL_1
1C0Eh			DLL_CNSoCJitter_REC Monitors the Jitter error (see object index 1C13h)
	0	1	NumberOfEntries_U8 = 3
	1	4	DLL_CNSoCJitterCum_U32
	2	4	DLL_CNSoCJitterThr_U32
	3	4	DLL_CNSoCJitterThreshold_U32 When reached state is changed to NMT_CS_PRE_OPERATIONAL_1
1C0Fh			DLL_CNCRCErrror_REC Monitors CRC errors
	0	1	NumberOfEntries_U8 = 3
	1	4	DLL_CNCRCErrrorCum_U32
	2	4	DLL_CNCRCErrrorThr_U32
	3	4	DLL_CNCRCErrrorThreshold_U32 When reached state is changed to NMT_CS_PRE_OPERATIONAL_1
1C10h			DLL_CNLossOfLink_REC Monitors Loss of Link errors
	0	1	NumberOfEntries_U8 = 1
	1	4	DLL_CNLossOfLink Cum_U32
1C13h		4	DLL_CNSoCJitterRange_U32 (ns) defines the jitter for SoC cycles

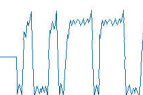

8.6. Communication interface description error

Object Index 1030h: NMT_InterfaceGroup_0h_REC

Object Index 1031h: NMT_InterfaceGroup_1h_REC

- Subindex 0: Number of Entries = 9
- Subindex 1: InterfaceIndex_U16 (ro) = 1
- Subindex 2: InterfaceDescription_VS (ro) = "HyNet32XS_EthCtrl"
- Subindex 3: InterfaceType_U8 (ro) = 6 (ethernet csmacd)
- Subindex 4: InterfaceMTU_U32 (ro) = 1500
- Subindex 5: InterfacePhysAddress_OSTR (ro) = MAC Address
- Subindex 6: InterfaceName_VS (rw) = "eth0"
- Subindex 7: InterfaceOperStatus_U8 (ro) = 0: Down, 1: Up
- Subindex 8: InterfaceAdminState_U8 (rw) = 0: Down, 1: Up
- Subindex 9: Valid_BOOL (rw) = TRUE

Object Index 1032h – 1039h: NMT_InterfaceGroup_xh_REC

- Subindex 9: Valid_BOOL (rw) = FALSE

Object Index 1F93h: NMT_EPLNodeId_REC

- Subindex 0: Number of Entries = 2
- Subindex 1: NodeId_U8 (ro), set by Hex-Switch
- Subindex 2: NodeIdByHW_BOOL (ro) = TRUE

8.7. Others

Object Index 1F99h: NMT_CnStateMachineTimeouts_REC

- Subindex 0: NumberOfEntries = 1
- Subindex 1: BasicEthernetTimeout_U32
Timeout in μ s before changing from NMT_CS_NOT_ACTIVE into NMT_CS_BASIC_ETHERNET state.

Object Index 1F50h: PDL_DownloadProgData_ADOM

- Subindex 0: Number of programs
(currently only 1 is supported, the default program)
- Subindex 1: Default Program (Firmware)

Object Index 1F51h: PDL_ProgCtrl_AU8

- Subindex 0: Number of entries
(currently only 1 is supported, the default program)
- Subindex 1: Program Control:

Value	Write Access	Read Access
0	Stop program (n/a)	program stopped
1	Start program	program running
2	Reset program	program stopped

Currently a read access will always return '1' and a write of '1' or '2' will initiate a reset and restart of the CN. This is needed to start a new downloaded firmware (Program 1).

Object Index 1F52h: PDL_LocVerAppISw_REC

- Version of the Default Program.
- Subindex 0: Number of entries (=2)
- Subindex 1: ApplSwDate_U32: Number of days since 1/1/1984
- Subindex 2: ApplSwTime_U32: ms since midnight

9. Accessories

As accessories the following materials will be offered:

9.1. 2-pin plug for the connection of voltage supply

- screw plug-in
- cage clamp plug-in

9.2. 9-pin plug for the connection of the periphery (I/O connection)

- screw plug-in
- cage clamp plug-in

9.3. Ethernet cable

CAT 5 STP (shielded twisted pair), standard length of 2m. Cable of other lengths is available on inquiry.

SHF Communication Technologies AG • Division Automation
Wilhelm-von-Siemens-Str. 23 E • D - 12277 Berlin

☎ +49 30 772 051 19 • 📠 +49 30 7702 9848 • ✉ automation@shf.de • 🌐 www.shf.de