

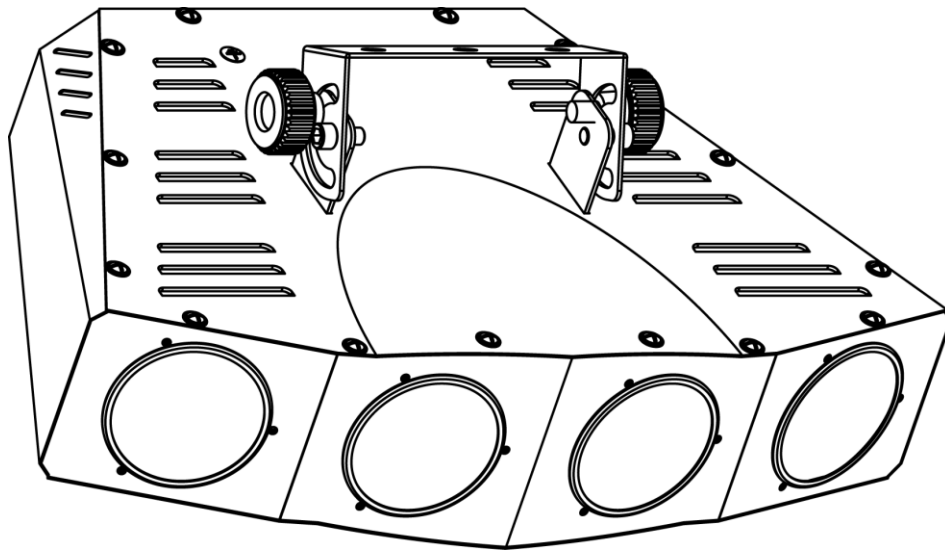

Snapshot

Use on Dimmer	⊘
Outdoor Use	⊘
Sound Activated	✓
DMX 512	✓
Master/Slave	✓
Autoswitching Power Supply	✓
Replaceable Fuse	✓
User Serviceable	⊘
Duty Cycle	⊘

User Manual

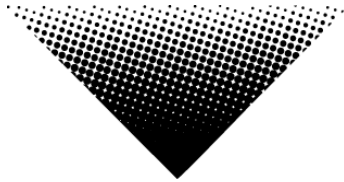

3000 N 29th Ct, Hollywood, FL 33020 U.S.A.
(800) 762-1084 – (954) 929-1115
FAX (954) 929-5560
www.chauvetlighting.com

TABLE OF CONTENTS

1. BEFORE YOU BEGIN	3
WHAT IS INCLUDED	3
UNPACKING INSTRUCTIONS	3
SYMBOLS.....	3
AC POWER	3
SAFETY INSTRUCTIONS.....	4
2. INTRODUCTION	4
FEATURES.....	4
<i>Additional Features</i>	4
DMX CHANNEL SUMMARY.....	5
PRODUCT OVERVIEW	5
3. SETUP	6
FUSE REPLACEMENT	6
FIXTURE LINKING.....	6
<i>DMX Data Cable</i>	6
<i>Cable Connectors</i>	7
<i>3-Pin to 5-Pin Conversion Chart</i>	7
<i>Setting up a DMX Serial Data Link</i>	7
MASTER/SLAVE FIXTURE LINKING	8
MOUNTING	8
<i>Orientation</i>	8
<i>Rigging</i>	8
4. OPERATING INSTRUCTIONS	9
OPERATION MODES.....	9
<i>Stand-Alone Mode (Sound-Active, Auto Mode)</i>	9
<i>Master/Slave Mode (Master Sound, Master Auto)</i>	9
<i>DMX Mode</i>	10
USING DMX MODE.....	10
<i>DMX Channel Values</i>	10
<i>Setting the Starting Address</i>	11
GENERAL TROUBLESHOOTING	11
CONTACT US.....	12
5. APPENDIX	12
DMX PRIMER	12
GENERAL MAINTENANCE	13
RETURNS PROCEDURE.....	13
CLAIMS.....	13
TECHNICAL SPECIFICATIONS	14

1. BEFORE YOU BEGIN

What is included

- 1 x Mega Moon™
- 1 x Power Cord
- 1 x Warranty Card
- 1 x User Manual

Unpacking Instructions

Immediately upon receiving a fixture, carefully unpack the carton, check the contents to ensure that all parts are present, and have arrived in good condition. Notify the shipper immediately and retain the packing material for inspection if any parts appear damaged from shipping or the carton shows signs of mishandling. Save the carton and all packing materials. In the event that a fixture must be returned to the factory, it is important that the fixture be returned in the original factory box and packing.

Symbols



This paragraph contains critical installation, configuration or operation information. Failure to comply with this information may render the fixture partially or completely inoperative, cause damage to the fixture or cause harm to the operator/user/technician.



This paragraph contains important installation or configuration information. Failure to comply with this information may prevent the fixture from functioning correctly.



This paragraph reminds you of useful, although not critical, information.

AC Power

This fixture has an auto-switching power supply that can accommodate a wide range of input voltages (100V - 240VAC, 50/60Hz). Before powering on the unit, make sure the line voltage to which you are connecting it is within the range of accepted voltages.



Always connect the fixture to a switched circuit. Never connect the fixture to a rheostat (variable resistor) or dimmer circuit, even if the rheostat or dimmer channel is used only as a 0% to 100% switch.

To determine the power requirements for a particular fixture, see the label affixed to the back plate of the fixture or refer to the fixture's specifications chart. A fixture's listed current rating indicates its average current draw under normal conditions.

Before applying power to a fixture, check that the source voltage matches the fixture's requirement. Check the fixture or device carefully to make sure that if a voltage selection switch exists, it is set to the correct line voltage you will use.



Always connect the fixture to a circuit with a suitable electrical ground.

Safety Instructions



Please read these instructions carefully, which include important information about the installation, usage and maintenance of this product.

- Please keep this User Guide for future consultation. If you sell the unit to another user, be sure that they also receive this instruction booklet.
- This product is for indoor use only! To prevent risk of fire or shock, do not expose fixture to rain or moisture.
- Make sure there are no flammable materials close to the unit while operating.
- Secure fixture to fastening device using a safety chain.
- Maximum ambient temperature (Ta) is 104°F (40°C). Do not operate the fixture at temperatures higher than this.
- In the event of a serious operating problem, stop using the unit immediately. Never try to repair the fixture by yourself. Repairs carried out by unskilled people can lead to damage or malfunction. Please contact the nearest authorized technical assistance center.
- Make sure the power cord is not crimped or damaged.
- Never disconnect the power cord by pulling or tugging on the cord.
- Avoid direct eye exposure to the light source while it is on.
- Do not daisy chain power to more than 37 units @ 120V.



There are no user serviceable parts inside the unit. Do not open the housing or attempt any repairs. In the unlikely event that your unit may require service, please contact CHAUVET at 954-929-1115.

2. INTRODUCTION

Features

- 6-channel DMX-512 LED beam effect
- Individual control of red, green, blue and white LEDs within each cluster (4 total)
- Adjustable strobe speed
- Built-in automated programs via DMX
- Built-in sound activated programs via master/slave or DMX

Additional Features

- Razor-sharp rotating beams
- Additional power output: max 37 units @ 120V

DMX Channel Summary

CHANNEL	FUNCTION
1	Module 1
2	Module 2
3	Module 3
4	Module 4
5	Strobe
6	Function

Product Overview

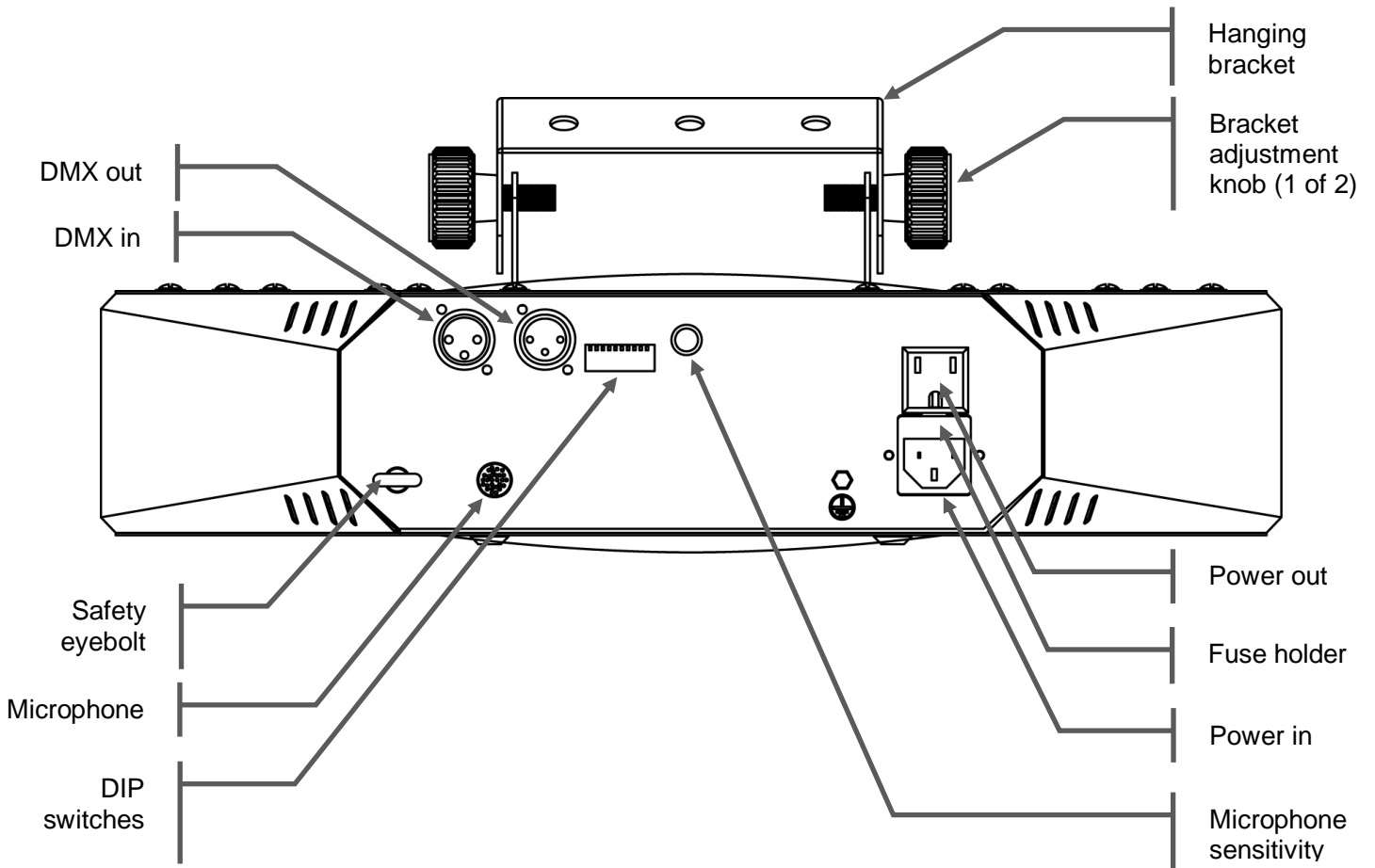

3. SETUP

Fuse Replacement



Disconnect the power cord before replacing a fuse and always replace with the same type of fuse.

With a flat head screwdriver, wedge the fuse holder out of its housing. Remove the blown fuse from its holder and replace with the exact same type of fuse. Insert the fuse holder back in its place and reconnect power.

The fuse is located inside this compartment. Remove using a flat head screwdriver.

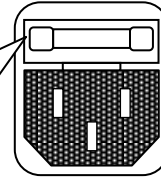

Fixture Linking

You will need a serial data link to run light shows of one or more fixtures using a DMX-512 controller or to run synchronized shows on two or more fixtures set to a master/slave operating mode. The combined number of channels required by all the fixtures on a serial data link determines the number of fixtures the data link can support.



Fixtures on a serial data link must be daisy chained in one single line. To comply with the EIA-485 standard no more than 32 devices should be connected on one data link. Connecting more than 32 fixtures on one serial data link without the use of an optically isolated DMX splitter may result in deterioration of the digital DMX signal.

Maximum recommended serial data link distance: 500 m (1640 ft.)

Maximum recommended number of fixtures on a serial data link: 32

DMX Data Cable

To link two or more fixtures together you must use DMX compliant data cables. You can purchase CHAUVET certified DMX cables directly from a dealer/distributor or construct your own cable.

If you choose to create your own cable, please use data-grade cables that can carry a high quality signal and are less prone to electromagnetic interference. Use a Belden© 9841 or equivalent cable, which meets the specifications for EIA RS-485 applications.



Standard microphone cables cannot transmit DMX data reliably over long distances.

The cable must have the following characteristics:

Type: shielded, 2-conductor twisted pair

Maximum capacitance between conductors: 30 pF/ft.

Maximum capacitance between conductor and shield: 55 pF/ft.

Maximum resistance: 20 ohms / 1000 ft.

Nominal impedance: 100 – 140 ohms

Cable Connectors

Cabling must have a male XLR connector on one end and a female XLR connector on the other end.

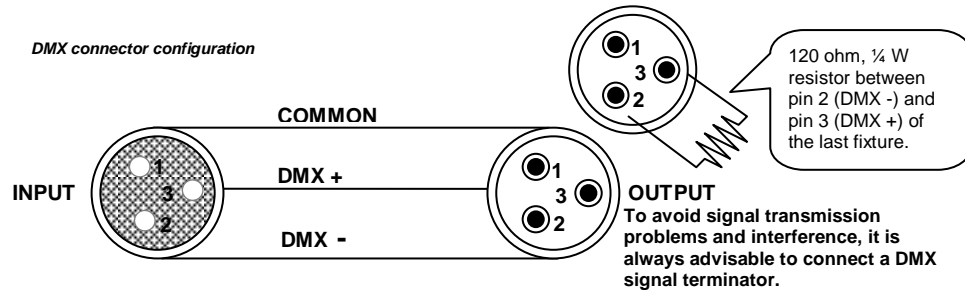

Do not allow contact between the common and the fixture's chassis ground. Grounding the common can cause a ground loop, and your fixture may perform erratically. Test the cables with an ohmmeter to verify correct polarity and to make sure the pins are not grounded or shorted to each other.

3-Pin to 5-Pin Conversion Chart



If you use a controller with a 5-pin DMX output connector, you will need to use a 5-pin to 3-pin adapter. You may use the CHAUVET Model number DMX5M, or DMX5F.

The chart below details the proper cable conversion:

3-PIN TO 5-PIN CONVERSION CHART		
Conductor	3-Pin Female (output)	5-Pin Male (Input)
Ground/Shield	Pin 1	Pin 1
Data (-) signal	Pin 2	Pin 2
Data (+) signal	Pin 3	Pin 3
Do not use		Pin 4
Do not use		Pin 5

Setting up a DMX Serial Data Link

1. Connect the (male) 3-pin connector of the DMX cable to the output (female) 3-pin connector of the controller.
2. Connect the other end of the cable to the (male) 3-pin input connector of the first fixture
3. Connect the cable from the output of the first fixture to the input of the second fixture.
4. Continue connecting the other features as indicated above.

CHAUVET Certified DMX Data Cables

Order Code	Description
DMX1.5	DMX Cable 1.5 m/4.9 ft
DMX4.5	DMX Cable 4.5 m/14.8 ft
DMX10	DMX Cable 10 m/32.8 ft

Universal DMX Controller

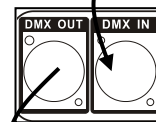
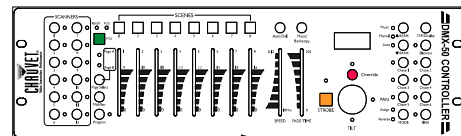

This drawing provides a general illustration of the DMX Input/Output panel of a lighting fixture.

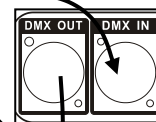

Continue the link

Master/Slave Fixture Linking

1. Link the fixtures as indicated in steps 1 to 4 of the previous section.
2. The setup of the Master/Slave or Stand-alone operation often requires the first fixture in the chain to be initialized accordingly via settings in the control.
3. In addition, in the Master/Slave mode, the fixtures that follow may also need to be initialized as “slaves.” Please consult the **Operating Instructions** section in this manual for complete instructions for this type of configuration.

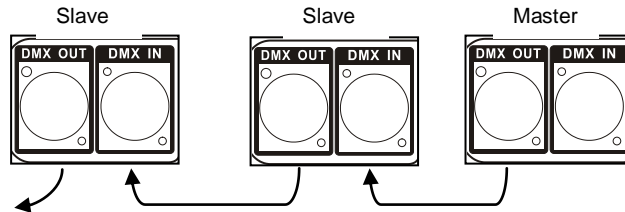

Mounting

Orientation

This fixture may be mounted in any safe position.

Rigging

It is important never to obstruct the vents pathway. Mount the fixture using a suitable “C” or “O” type clamp. Adjust the angle of the fixture by loosening both knobs and tilting the fixture. After finding the desired position, retighten both knobs.

- When selecting an installation location, consider ease of access to the fixture for operation and routine maintenance.
- Always use safety cables.
- Never mount the fixture in places where it may be exposed to rain, high humidity, extreme temperature changes or restricted ventilation.

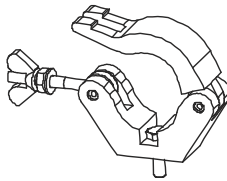

Hanging Clamp



The clamp is sold separately

4. OPERATING INSTRUCTIONS

Operation Modes

The fixture may be operated on stand-alone (sound activated), Master/Slave Mode or DMX Mode.

Stand-Alone Mode (Sound-Active)

This mode allows a single fixture to run to the beat of the music, or the fixture will change automatically in Auto Mode.

- 1) Set the DIP switches position to Sound Active or Auto Mode.

Mode	DIP switches
Master sound-active	1-10 = Off

- 2) The fixture will react to the low frequencies of music via the internal microphone in Sound Active mode.
- 3) Use the audio sensitivity knob on the back of the fixture to make the fixture more or less sensitive in Sound-Active mode. Turning the knob counterclockwise decreases the sensitivity; turning the knob clockwise increases the sensitivity.

Note: *To use the fixture in automatic (without the sound trigger), you must use a DMX controller.*

Master/Slave Mode (Sound)

This mode will allow you to link up to 32 fixtures together without a controller.

- 1) Use standard DMX cables to daisy chain your fixtures together via the DMX connector on the rear of the fixtures. (For longer cable runs, we suggest a terminator at the output of the last fixture).
- 2) Choose a fixture to function as the Master. Turn DIP switches to the Master position on the fixture. The Master fixture must be the first fixture in line.
- 3) Please see the DIP switches settings for Stand-Alone Mode (described above) to set the fixture to the Master setting of your choice.
- 4) Turn the DIP switches to the Slave position on the Slave fixture, and they will react the same as the Master.

Mode	DIP switches
Slave	1-10 = Off

DMX Mode

This mode allows the fixture to receive control from any universal DMX controller.

Using DMX Mode



If you are unfamiliar with DMX, please read the DMX Primer section.

- 1) Using DMX cables, daisy chain the fixture(s), starting from the output of the DMX controller.
- 2) Assign the individual DMX address, using DIP switches 1 - 9 on each fixture.
- 3) Set the fixture to DMX operation mode by turning DIP switch 10 to the on position.

DMX Channel Values

CHANNEL	VALUE	FUNCTION
		Module 1-4
	000 ⇔ 010	No function
	011 ⇔ 016	Group 1 of White
	017 ⇔ 022	Group 2 of White
	023 ⇔ 028	Group 3 of White
	029 ⇔ 034	Group 1 of Red
	035 ⇔ 040	Group 2 of Red
	041 ⇔ 046	Group 3 of Red
	047 ⇔ 052	Group 1 of Green
	053 ⇔ 058	Group 2 of Green
	059 ⇔ 064	Group 3 of Green
	065 ⇔ 070	Group 1 of Blue
	071 ⇔ 076	Group 2 of Blue
	077 ⇔ 082	Group 3 of Blue
	083 ⇔ 088	All White
	089 ⇔ 094	All Red
	095 ⇔ 100	All Green
	101 ⇔ 106	All Blue
1-4	107 ⇔ 112	All Red & Green
	113 ⇔ 118	All Red & Blue
	119 ⇔ 124	All Green & Blue
	125 ⇔ 130	All Red & Green & Blue
	131 ⇔ 136	All Red & White
	137 ⇔ 142	All Green & White
	143 ⇔ 148	All Blue & White
	149 ⇔ 154	Group 1 of Blue & all White
	155 ⇔ 160	Group 2 of Blue & all Red
	161 ⇔ 166	Group 3 of Blue & all Green
	167 ⇔ 172	Group 1 of Blue & group 3 of Red
	173 ⇔ 178	Group 2 of Blue & group 2 of Red
	179 ⇔ 184	Group 3 of Blue & group 1 of Red
	185 ⇔ 190	Group 1 of Green & group 3 of White
	191 ⇔ 196	Group 2 of Green & group 2 of White
	197 ⇔ 202	Group 3 of Green & group 1 of White
	203 ⇔ 208	Group 1 of Blue, group 3 of Green, group 1 of Red, & group 3 of White
	209 ⇔ 214	Group 2 of Blue, group 2 of Green, group 2 of Red, & group 2 of White
	215 ⇔ 220	Group 3 of Blue, group 1 of Green, group 3 of Red, & group 1 of White
	221 ⇔ 255	All White & Red & Green & Blue
		Strobe
5	000 ⇔ 010	No function
	011 ⇔ 255	Strobe: (Slow > Fast)
		Function
	000 ⇔ 010	No function
	011 ⇔ 036	Program 1
	037 ⇔ 062	Program 2
	063 ⇔ 088	Program 3
6	089 ⇔ 114	Program 4
	115 ⇔ 130	Program 5
	131 ⇔ 156	Program 6
	157 ⇔ 182	Program 7
	183 ⇔ 208	Program 8
	209 ⇔ 250	Auto mode
	251 ⇔ 255	Sound mode

Setting the Starting Address



If this is your first time addressing a fixture using the DMX-512 control protocol, we suggest you to go to the Appendix Section and read the DMX Primer section. It contains very useful information that will help you understand how DMX works.

General Troubleshooting

Symptom	Solution(s)	Applies to			
		Lights	Foggers & Snow	Controllers	Dimmers & Chaser
Auto shut off	Check fan thermal switch reset	✓			
Beam is very dim or not bright	Clean optical system or replace lamp Check 220/110 V switch for proper setting	✓			
Breaker/Fuse keeps blowing	Check total load placed on device				✓
Chase is too slow	Check user's manual for speed adjustment	✓		✓	✓
Device has no power	Check for power on Mains. Check device's fuse. (internal and/or external)	✓		✓	✓
Fixture is not responding	Check DMX Dip switch settings for correct addressing Check DMX cables Check polarity switch settings	✓			
Fixture is on but there is no movement to the audio	Make sure you have the correct audio mode on the control switches. If audio provided via ¼" jack, make sure a live audio signal exists Adjust sound sensitivity knob	✓		✓	✓
Light will not come on after power failure	Some discharge lamps require a cooling off period before the electronics in the fixture can kick start it again. Wait 5 to 10 minutes before powering it up again.	✓			
Loss of signal	Use only DMX cables Install terminator Note: Keep DMX cables separated from power cables or black lights.	✓	✓	✓	✓
No flash	Re-install bulb; it may have shifted in shipping	✓			
No light output	Check slip ring & brushes for contact Install bulb Call service technician	✓			
Relay will not work	Check reset switch Check cable connections				✓
Remote does not work	Make sure connector is firmly attached to device	✓	✓		

If you still have a problem after trying the above solutions, please contact CHAUVET Technical Support at the location on the next page.

Contact Us

World Wide

General Information

CHAUVET
3000 North 29th Court
Hollywood, FL 33020
voice: 954.929.1115
fax: 954.929.5560
toll free: 800.762.1084

Technical Support

CHAUVET
3000 North 29th Court
Hollywood, FL 33020
voice: 954.929.1115 **(Press 4)**
fax: 954.929.5560 **(Attention: Service)**

World Wide Web

www.chauvetlighting.com

5. APPENDIX

DMX Primer

The DMX mode enables the use of a universal DMX controller device. There are 512 channels in a DMX-512 connection. Channels may be assigned in any manner. A fixture capable of receiving DMX 512 will require access to one or more sequential channels. To do this, each fixture requires a "start address" from 1 to 512. A fixture requiring one or more channels for control begins to read the data on the channel indicated by the start address. For example, a fixture that uses six DMX channels and was addressed to start on DMX channel 100, would read data from channels: 100, 101, 102, 103, 104, and 105.

The user must assign a starting address on the fixture that indicates the first channel reserved in the controller. There are many different types of DMX controllable fixtures and they all may vary in the total number of channels required. Choosing a start address should be planned in advance. Channels should never overlap. If they do, this will result in erratic operation of the fixtures whose starting address are set incorrectly. However, you can control multiple fixtures of the same type using the same starting address as long as the intended result is that of unison movement or operation. In other words, the fixtures will be slaved together and they will all respond in exactly the same way.

DMX fixtures are designed to receive data through a serial DMX Daisy Chain. In a Daisy Chain, the DATA OUT of one fixture connects to the DATA IN of the next fixture. The order in which the fixtures are connected is not important and has no effect on how a controller communicates to each fixture. Use an order that provides for the easiest and most direct cabling, however.

Connect the fixtures using a shielded, two-conductor twisted pair cable with one 3-pin XLR male connector on one end and a 3-pin XLR female connector on the other end. The shield connection is pin 1, while pin 2 is Data Negative (S-) and pin 3 is Data positive (S+). See page 6 for details on this type of cable.



CHAUVET carries 3-pin XLR DMX compliant cables, DMX-10 (33'), DMX-4.5 (15') and DMX-1.5 (5')

General Maintenance

To maintain optimum performance and minimize wear, fixtures should be cleaned frequently. Usage and environment are contributing factors in determining the cleaning frequency. As a general rule, fixtures should be cleaned at least twice a month. Dust build up reduces light output performance and can cause overheating. This can lead to reduced lamp life and increased mechanical wear. Be sure to power off fixture before conducting maintenance.

Unplug fixture from power. Use a vacuum or air compressor and a soft brush to remove dust collected on external vents and internal components. Clean all glass surfaces when the fixture is cold with a mild solution of glass cleaner or Isopropyl Alcohol and a soft lint-free cotton cloth or lens tissue. Apply solution to the cloth or tissue and drag dirt and grime to the outside of the lens. Gently polish optical surfaces until they are free of haze and lint.

The cleaning of internal and external optical lenses and/or mirrors must be carried out periodically to optimize light output. Cleaning frequency depends on the environment in which the fixture operates: damp, smoky or particularly dirty surrounding can cause greater accumulation of dirt on the unit's optics. Clean with soft cloth using normal glass cleaning fluid. Always dry the parts carefully. Clean the external optics at least every 20 days. Clean the internal optics at least every 30/60 days.

Returns Procedure

Returned merchandise must be sent prepaid and in the original packing; call tags will not be issued. Package must be clearly labeled with a Return Merchandise Authorization Number (RMA #). Products returned without an RMA # will be refused. Call CHAUVET and request an RMA #, prior to shipping the fixture. Be prepared to provide the model number, serial number and a brief description of the cause for the return. Be sure to properly pack fixture; any shipping damage resulting from inadequate packaging is the customer's responsibility. As a suggestion, proper UPS packing or double-boxing is always a safe method to use. CHAUVET reserves the right to use its own discretion to repair or replace product(s).



Once you have received the RMA#, please include the following information on a piece of paper inside the box:

- 1) Your name
- 2) Your address
- 3) Your phone number
- 4) The RMA #
- 5) A brief description of the symptoms

Claims

Damage incurred in shipping is the responsibility of the shipper; therefore, any damage must be reported to the carrier upon receipt of merchandise. It is the customer's responsibility to notify and submit claims with the shipper in the event that a fixture is damaged during shipping. Any other claim for items such as missing component/part, damage not related to shipping, and concealed damage must be made within seven (7) days of receiving merchandise.

Technical Specifications

WEIGHT & DIMENSIONS

Length 18.3 in (465 mm)
Width 12.2 in (310 mm)
Height 6.7 in (170 mm)
Weight 8.9 lbs (4 kg)

POWER

Autoswitching 100-240 VAC 50/60 Hz
Fuse F2 A 250 V (5 x 20 mm fast-blow)
Power Consumption 18 W (0.2 A) max @ 120 V
Inrush Current (0.2 A) @ 120 V
Power Consumption 17 W (0.1 A) max @ 230 V
Inrush Current (0.1 A) @ 230 V
Power Output 37 units max @ 120 VAC, 74 units max @ 230 V

LIGHT SOURCE

LED 228 (48 Red, 72 Green, 72 Blue, 36 White) 100,000 hrs

COVERAGE

Coverage angle (horizontal spread) 74°

THERMAL

Maximum ambient temperature 104° F (40° C)

CONTROL & PROGRAMMING

Data input locking 3-pin XLR male socket
Data output locking 3-pin XLR female socket
Data pin configuration pin 1 shield, pin 2 (-), pin 3 (+)
Protocols DMX-512 USITT
DMX Channels 6

ORDERING INFORMATION

Mega Moon™ MEGAMOON

WARRANTY INFORMATION

Warranty 2-year limited warranty