



DIVISIONE ELETTRONICA E SISTEMI

ZFD8N

**DIGITAL MULTIFUNCTION RELAY
DIRECTIONAL PHASE - OVERCURRENT AND
EARTH-FAULT WITH
AUTO-RECLOSING FUNCTION OR
UNDER-IMPEDANCE RELAY**

USER MANUAL

P501D802

October 2004

INDEX

1	GENERAL CHARACTERISTICS.....	1
1.1	Directional thresholds.....	4
1.2	Directional overcurrent (ANSI 67).....	6
1.3	Phase overcurrent (ANSI 50 - 51).....	8
1.4	Directional earth-fault - 3 independent thresholds.....	8
1.4.1	Directional earth-fault with non-operating zone around the origin.....	8
1.4.2	Directional earth-fault characteristic angles.....	9
1.4.3	Earth-fault overcurrent (ANSI 51N).....	9
1.5	Residual overvoltage (ANSI 59N).....	9
1.6	Under-impedance (ANSI 21).....	9
1.7	Auto-reclosing function (ANSI 79).....	11
2	FRONT PANEL KEYS.....	14
3	FRONT PANEL LED SIGNALING.....	15
4	PROGRAMMING AND TEST.....	16
4.1	How to program the protection relay.....	16
4.2	How to modify a visualized parameter.....	17
4.3	Reset.....	17
4.4	Test of output relays.....	18
5	DISPLAY AND PROGRAMMING.....	19
5.1	Standard display (fig. 3).....	19
5.2	Visualization structure.....	21
5.3	Address and time (fig. 3).....	26
5.4	Function selection (fig. 3).....	27
5.5	Nominal values set-up (fig. 4).....	29
5.6	Thresholds and time delays set-up (fig. 4).....	30
5.6.1	ANSI 67 thresholds programming (fig. 4).....	31
5.6.2	ANSI 21 thresholds programming - (fig. 4).....	34
5.6.3	ANSI 67N thresholds programming - (fig. 4 and fig. 5).....	37
5.6.4	ANSI 67N threshold SA programming - (fig. 5).....	40
5.6.5	ANSI 59N threshold $U_{o>>}$ programming - (fig. 5).....	43
5.6.6	ANSI 79 - Auto-reclosing function programming - (fig. 5).....	44
5.7	Output relays programming (fig. 5).....	45
5.8	Digital inputs function programming (fig. 6).....	47
5.9	Special function - voltage memory function (fig. 6).....	49
5.10	Parameter values visualization (fig. 6).....	49
5.11	Events (fig. 7).....	51
5.12	Trips counters (fig. 7).....	54
6	INSTALLATION.....	55
6.1	Supplied kit.....	55
6.2	Cabling.....	56
6.3	Relays R3 and R4 - Signaling / Command set-up.....	61
6.4	RS485 serial communication port.....	61
7	TIME DEPENDENT CURVES - IEC 255-4.....	63
8	TECHNICAL DATA.....	64
9	TABLE.....	66

Information printed in this manual subject to change without prior notice.

This manual must not be reproduced in whole or in part, in any form or by any means without the express written permission of SEB Divisione Elettronica e Sistemi.

1 GENERAL CHARACTERISTICS

The protection relay ZFD8N is designed to perform the following functions:

Directional overcurrent three-phase (or two-phase)	ANSI 67
Three-phase overcurrent (or two-phase)	ANSI 50-51
Auto-reclosing	ANSI 79

or

Directional under-impedance	ANSI 21
NON directional under-impedance	ANSI 21

There are also available the following functions:

Directional earth-fault	ANSI 67N
Earth-fault overcurrent	ANSI 50N-51N
Residual overvoltage	ANSI 59N

All the functions related to ANSI code 67-50-51, 67N-51N, 59N and 79 are available at the same time to guarantee with a protection module all the functions to manage:

- protection of main rings
- protection of MV feeders

The directional or NON-directional under-impedance function (ANSI 21) can be activated as alternative to the phase overcurrent functions (ANSI 67 or ANSI 50-51 and auto-reclosing function ANSI 79).

The directional earth fault function is used in electrical systems with:

- unearthed neutral
- neutral solidly earthed
- neutral earthed through a resistor
- via earthing transformer
- neutral earthed through Petersen coil

All the set-up and measured parameters can be visualized on the front panel display and transmitted on the RS485 communication serial port.

THRESHOLDS - the following thresholds are available:

- 3 directional or non-directional overcurrent thresholds
- 3 directional or non directional earth fault thresholds (earth current and residual voltage)
- 1 residual overvoltage threshold

or

- 3 directional or non-directional under-impedance thresholds

- 3 directional or non directional earth fault thresholds (earth current and residual voltage)
- 1 residual overvoltage threshold

The directional earth-fault function can be selected as:

- 3 INDEPENDENT DIRECTIONAL thresholds
- DIRECTIONAL with NON operating zone around the origin (see 1.4.1)

The available settings for each threshold are listed in Table A; the operation of the directional thresholds is described in paragraph 1.1.

TRIP DELAYS - a programmable time delay (TI) is available for each threshold; it can be programmed as definite time; the first threshold of the function ANSI 67-50-51 (**S1**) and ANSI 67N-51N (**NS1**) can be programmed as time definite or time dependent in compliance with IEC 255-4 standard.

For each threshold programmed as definite time, an additional programmable time delay (TA) is available; the additional time delay is added to time delay TI. The additional time delay activation is controlled by the digital inputs to allow the use of the ZFD8N relay with cooperating protection relays.

The available settings for each time delay are listed in Table A

OUTPUT RELAYS - the ZFD8N controls 4 output relays (named R1, R2, R3 and R4); these relays can be programmed to be activated on START or TRIP conditions of one or more thresholds.

START	instantaneous activation of the output relay when at least one of the measured current or parameter exceeds the programmed threshold value
TRIP	activation of the output relay when the programmed time delay (TI or TI+TA) related to a threshold expires.

The output relays can be also programmed on auto-reclosing functions (ANSI 79) such as:

- reclosing command to switch-gear
- successful reclosing function (79 OK)
- failed reclosing function (79 FR)
- reclosing function in progress (79 ON)

The quiescent state of each single relay R1, R2, R3 and R4 can be programmed as normally energized (ON) or normally de-energized (OFF).

An additional relay R5 (normally energized) is controlled by the self-diagnosis routines to report detected fault conditions.

Related to each threshold, partial and total counters of TRIP conditions are available.

DIGITAL INPUTS - there are available 6 digital inputs to activate the following functions (when enabled by the programmed set-up):

- additional time delay (related to one or more thresholds)
- on/off thresholds
- STATUS function (recording of measures on external event)
- pilot wire fault monitoring
- sensing of commands to the switch-gear (close/open)

For each digital input can be programmed the condition that activates the related functions:

HI voltage =	> 20 V dc / ac
LO voltage =	0 ÷ 10 V dc / ac

The digital input acquisition is valid when the voltage value stays in the range HI or LO for at least 40 ms.

DISPLAY OF MEASURES - the user can select the continuous display of a measured parameter (current, voltage, phase, impedance etc.); all the measured and computed parameters can be transmitted to an external controller through the RS485 port.

EVENTS - information related to the last 5 events (TRIP or STATUS) are recorded in the EEPROM memory.

Information includes the threshold set-up and activated relays (TRIP event only), the measured currents, voltages, phases, impedance, the digital input status, date and time of the event.

SELF-DIAGNOSIS - the software includes a non stop monitoring module that controls the functionality of all hardware and software resources of the protection relay.

Detected fault conditions are reported by:

- diagnostic message on the display
- glow of a red LED on front panel
- R5 output relay drop-off

The fault condition signaling stays until faults are pointed out by the monitoring module; during this condition the protection functions are suspended to avoid unsuitable tripping.

STATUS FUNCTION - when the STATUS function is activated by one of the digital input (when programmed) the protection relay memorizes information related to measured parameters and digital input status (see par. 5.11 - EVENTS). The recorded information allows an analysis of trip causes in co-operative protection relays systems.

PILOT WIRE FAULT MONITORING - when the function is programmed, the digital input DIG2 is used to control the correct functionality of the pilot wire. Digital input DIG2 is always expected to be complementary of DIG1 input (HI-LO or LO-HI) to identify faults on pilot wire.

The fault condition is reported as detected by the self-diagnosis module but the protection functions are not suspended; only the functions related to DIG1 digital input are suspended as the DIG1 status cannot be longer considered as true.

The fault condition is reported when DIG1 and DIG2 signals are not complementary for more then 100 ms.

REMOTE COMMUNICATION - the opto-insulated serial port RS485 can communicate with a personal computer or a remote control and monitoring system equipped with an RS485 interface or with a standard RS485/RS232 converter.

It is possible to select the communication standard between STANDARD (ASCII 7 bit - Seb protocol) or MODBUS (ASCII mode, SLAVE).

All the set-up and measured parameters can be transmitted on the RS485 communication serial port; when communication is active (LED REMOTE glows), the operator on front panel can visualize the relay set-up but changes of parameters are disabled (ENTER and  buttons disabled).

VOLTAGE MEMORY FUNCTION - when the relay is working as directional overcurrent relay (ANSI 67) or a directional impedance relay (ANSI 21) the VOLTAGE MEMORY function can be programmed by the operator.

When the function is active, if a close fault condition occurs and the reference voltage suddenly drops to very small values (lower than the threshold **USs>** related to the directional overcurrent thresholds **S1, S2, S3** or lower then threshold **UZs>** related to the directional under-impedance thresholds **Z1, Z2, Z3**) the protection relay keeps for 500 ms a memorized reference voltage corresponding to the system voltage prior to the fault and thus the relay can operate properly.

The memorized reference voltage is related to system frequency before the incidence of the fault.

1.1 Directional thresholds

The ZFD8N protection relay measures voltages and currents and computes the phase angle between each voltage (reference) and the related current. The nominal current (I_n) and nominal voltages (U_n and U_{on}) are programmable; as regards the nominal earth current (I_{on}) two models of ZFD8N relay (1A or 5A) are available to match the nominal current of the installed earth CT.

In general terms each directional threshold is defined (independently of each other) by the following parameters:

$I_x>$, $Z_x<$	overcurrent or under-impedance threshold (e.g. $I1>$, $Z1<$)
$U_x>$	overvoltage threshold (e.g. $USs>$ ANSI 67)
$\Phi_x<$	angular sector threshold

ANGULAR SECTOR THRESHOLD - the threshold is defined by the following parameters:

Φ_x	characteristic angle (e.g. Φ_{NS1} related to ANSI 67N)
----------	--

DΦx sector width (e.g. **DΦZ2** related to ANSI 21)

CHARACTERISTIC ANGLE - The characteristic angle is defined with the measured voltage as reference (straight line C in figure 1).

The characteristic angle can be programmed from +180° to -180° and it is shown using the notation **Φx**. The angle **Φx** of the sector axis is positive when lagging the voltage vector (see figure 1).

SECTOR WIDTH - the sector width is symmetrically defined referred to the straight line C. The sector width can be programmed from +15° to +180° and it is shown using the notation **DΦx**.

DIRECTIONAL THRESHOLD OPERATION - The directional threshold (e.g. **NS1 - ANSI 67N** directional earth-fault) operates when the following conditions are verified:

- the measured current is greater than the threshold **Io1>**
- the measured voltage is greater than the threshold **Uo1>**
- the measured current phasor is within the sector defined by the parameter **ΦNS1** and **DΦNS1**.

therefore if the following characteristic angle is programmed:

$$\Phi_{NS1} = +90^\circ \quad D \Phi_{NS1} = 15^\circ$$

the directional threshold will operate if the angle of the measured current phasor is lagging the voltage phasor from +75° to +105° (+90° ±15°).

For the available settings of the thresholds **Ix>**, **Us>** and of the parameters **Φx** and **DΦx** please refer to Table A.

NON DIRECTIONAL THRESHOLDS - When the sector width **DΦx** is defined equal to 180° the threshold becomes non-directional and the voltage threshold is indifferent (only the modules of the measured currents or impedances are taken into consideration by the protection relay).

This functionality allows the programming of additional non-directional thresholds to obtain a higher degree of protection.

Every threshold can be programmed ON / OFF or disabled with an external command through digital inputs.

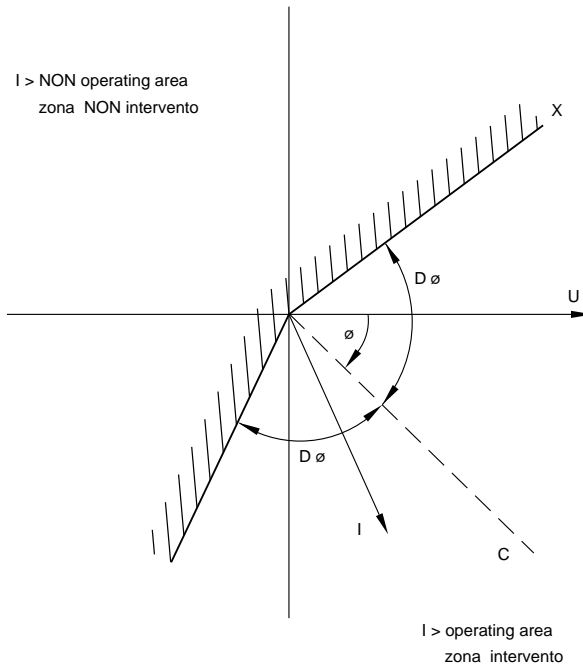

Figure 1

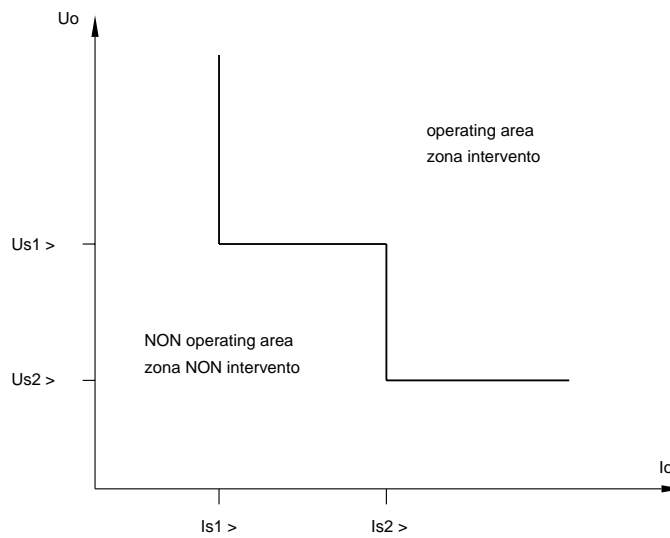

Figure 2

1.2 Directional overcurrent (ANSI 67)

There are available 3 directional overcurrent independent thresholds defined by the following current and voltage thresholds and angular threshold parameters:

- threshold **S1** - $I_{s1} >$, $U_{s1} >$, $\Phi S1 <$ (parameter $\Phi S1$ and $D\Phi S1$)
- threshold **S2** - $I_{s2} >$, $U_{s2} >$, $\Phi S2 <$ (parameter $\Phi S2$ and $D\Phi S2$)
- threshold **S3** - $I_{s3} >$, $U_{s3} >$, $\Phi S3 <$ (parameter $\Phi S3$ and $D\Phi S3$)

Each current threshold $I_{sx} >$ and each angular sector (characteristic angle ΦSx and sector width $D\Phi Sx$) is independently programmable; the voltage threshold $U_{sx} >$ is common to the 3 directional threshold and it is defined in the **S1** threshold programming section.

The threshold **S1** can be programmed as definite time or dependent time, whilst the remaining thresholds are time definite only (see curves paragraph 7)

Each threshold **S1**, **S2** and **S3** can be activated or disabled by the user. The protection operates on the directional threshold **Sx** if AT THE SAME TIME the measured current and voltage are greater than the thresholds **Isx>** and **Uss>** and if the current phasor is in the angular sector defined as $\Phi Sx \pm D\Phi Sx$ (with the measured voltage as reference).

The available settings for each time delay are listed in Table A

NOTE It is suggested to program the overvoltage threshold **Uss>** (common to the 3 thresholds) at the minimum value allowed by the installation characteristics to obtain the relay operates independently from the voltage level; it is suggested to avoid to program the threshold **Uss>** lower than 1 V (VT secondary value).

VOLTAGE MEMORY FUNCTION

When the function is active, if a close fault condition occurs and the reference voltage suddenly drops to very small values (lower than the threshold **Uss>** related to the directional overcurrent thresholds **S1**, **S2**, **S3**) the protection relay keeps for 500 ms a memorized reference voltage corresponding to the system voltage prior to the fault and thus the relay can operate properly.

The memorized reference voltage is related to system frequency before the incidence of the fault.

2-PHASE or 3-PHASE INSERTION - it is possible to select 2-PHASE or 3-PHASE insertion (ref. paragraph 5.4 - C1) depending on CT's available.

For the insertion please refer to figure 8 paragraph 6.

CHARACTERISTIC ANGLES - when it operates as directional overcurrent the following characteristic angles are suggested (refer to figure 3 for the surveillance direction):

$\Phi Sx = -30^\circ$ for MV feeders and ring mains

$\Phi Sx = -45^\circ$ for transformer feeders in order to ensure correct relay operation for fault beyond the transformer

For these applications the suggested sector width (**DΦSx**) is 83°.

In main rings it is possible to use the pilot wire (thresholds with additional time delay controlled by digital inputs) that allows a shorter time to disconnect the faulty section (two delay values and the same threshold, independently of the number of sections)

NON-DIRECTIONAL OPERATION - When a sector width **DΦSx** is defined equal to 180° the related overcurrent threshold **Sx** becomes non-directional (ANSI 50-51); for the available settings of the thresholds please refer to Table A.

These constraints are verified by the protection relay during the set-up and an error message will be displayed if required.

The **NS3** threshold operates normally with the parameters $I_{o3>}$, $U_{o3>}$ and $\Phi_{NS3<}$

1.4.2 Directional earth-fault characteristic angles

When it operates as directional earth-fault the following characteristic angles Φ_{NSx} (where $x = 1, 2, 3, A$) are suggested:

- | | |
|----------------------------|------|
| • unearthed | +90° |
| • solidly earthed | -75° |
| • via earthing resistor | 0° |
| • via earthing transformer | -90° |
| • via Petersen coil | 0° |

The suggested sector width $D\Phi_{Nx}$ in the first 4 cases is 85°

With unearthed systems the threshold **NS3** could be programmed with -90° characteristic angle to be used as reserve function against earth faults on different lines.

With solidly earthed system it is suggested to use the phase overcurrent threshold ANSI 67.

1.4.3 Earth-fault overcurrent (ANSI 51N)

When a sector width $D\Phi_{Sx}$ is defined equal to 180° the related overcurrent threshold **NSx** becomes non-directional (ANSI 51N); the threshold operates on the current threshold $I_{ox>}$ only and the voltage threshold is indifferent.

1.5 Residual overvoltage (ANSI 59N)

A residual overvoltage threshold $U_{o>>}$ independent from the voltage thresholds related to the directional earth fault function is available.

This threshold is time definite.

The available settings for each time delay are listed in Table A

1.6 Under-impedance (ANSI 21)

The under-impedance relay is used as back-up protection to generators and generator-transformer groups for the following functions:

- overcurrent
- loss-of-excitation
- under-excitation

The operating characteristics are the followings:

DIRECTIONAL under-impedance	circular sector on the plan R-X
NON-DIRECTIONAL under-impedance	circle on the plan R-X

DIRECTIONAL OPERATION

There are available 3 directional independent under-impedance thresholds defined by the following parameters:

threshold Z1 - Z1<, UZs>, $\Phi Z1<$	(parameter $\Phi Z1$ and $D\Phi Z1$)
threshold Z2 - Z2<, UZs>, $\Phi Z2<$	(parameter $\Phi Z2$ and $D\Phi Z2$)
threshold Z3 - Z3<, UZs>, $\Phi Z3<$	(parameter $\Phi Z3$ and $D\Phi Z3$)

Each under-impedance threshold $Zx<$ and each angular sector (characteristic angle ΦZx and sector width $D\Phi Zx$) is independently programmable; the voltage threshold $UZs>$ is common to the 3 directional threshold and it is defined in the **Z1** threshold programming section.

The thresholds are definite time only.

It is suggested to program the overvoltage threshold $UZs>$ (common to the 3 thresholds) at the minimum value allowed by the installation characteristics to obtain the relay operates independently from the voltage level; it is suggested to avoid to program the threshold $UZs>$ lower than 1 V (VT secondary value).

The under-impedance thresholds are defined in terms of Zn ($Zn = Un / In$).

Each threshold **Z1**, **Z2** and **Z3** can be activated or disabled by the user. The protection operates on the directional threshold Zx if AT THE SAME TIME:

- the measured impedance is lower than the thresholds $Zx<$
- the current phasor is in the angular sector defined as $\Phi Zx \pm D\Phi Zx$ (with the measured voltage as reference).

When the sector width $D\Phi Zx$ is defined equal to 180° the threshold becomes non-directional; this functionality allows the programming of additional non-directional thresholds to obtain a higher degree of protection.

The available settings for each threshold and time delay are listed in Table A

NON - DIRECTIONAL OPERATION

At function selection level (ref. paragraph 5.4 - C2) it is possible to select the NO-DIREZ (NON directional) selection; the selection is effective for ALL THE UNDER-IMPEDANCE THRESHOLDS.

The protection operates only on the measured impedance modules.

INSERTION

At function selection level (ref. paragraph 5.4 - C1) it is possible to select the relay insertion:

MIN Z-D	operation measuring the phase to phase voltages
MIN Z-Y	operation measuring the phase to earth voltages

The insertion diagrams are in the following figures:

fig. 8 - phase to phase (cross polarization)
fig. 9 - phase to earth voltage insertion

MEASURED VALUES

The measured values of the impedances and their thresholds are expressed in terms of Z_n and impedance (Ohm).

The impedance value is function of:

- plant CT's ratio
- plant VT's ratio
- n° of circuits (x1 insertion MIN Z-Y, x2 insertion MIN Z-D)

MINIMUM CURRENT INHIBITION (0.1 In)

The under-impedance function is inhibited when the measured current is lower than 0.1 In.

When the measured voltage is lower than the programmable voltage threshold **UZs>** (common to the 3 thresholds) and the related measured current is greater than 0.1 In, the relay:

trips when non directional function is selected

activates the voltage memory function when the directional function is selected

VOLTAGE MEMORY FUNCTION

When the function is active, if a close fault condition occurs and the reference voltage suddenly drops to very small values (lower than the threshold **UZs>** related to the directional overcurrent thresholds **Z1, Z2, Z3**) the protection relay keeps for 500 ms a memorized reference voltage corresponding to the system voltage prior to the fault and thus the relay can operate properly.

The memorized reference voltage is related to system frequency before the incidence of the fault.

1.7 Auto-reclosing function (ANSI 79)

The multi-shot auto-reclosing function can be activated for one or more of the thresholds related to ANSI 67 (50-51), 67N (51N) and 59N-59Vo; the auto-reclosing is **INHIBITED** when the under-impedance function (ANSI 21) is selected.

The function starts when one of the threshold (ENABLED on the auto-reclosing function) trips; one of the output relays must be programmed on the auto-reclosing function (ref. F12, paragraph 5.7)

It is possible to program the first reclosure (RR) on the first TRIP condition and from 0 to 4 additional reclosures (RL) on the following trips. During the reclosing operations the condition is showed on the display

The programmable parameters are showed in the table below.

Parameters		Setting	Resolution
NRL	N° of additional reclosures (except first)	0 ÷ 4	1
TRR	Dead time 1	0.1 ÷ 200.0 s	0.1 s
TN1	Reclaim time 1	0.1 ÷ 200.0 s	0.1 s
TRL	Dead time 2, 3, 4, 5	0.1 ÷ 200.0 s	0.1 s
TN2	Reclaim time 2, 3, 4, 5	0.1 ÷ 200.0 s	0.1 s
TD	Lockout time (inhibition of further reclosures)	0.0 ÷ 200.0 s	0.1 s

The lockout time TD is activated at the same time with the dead time TN2 and if a trip of a protection threshold occurs during the lockout time the auto-reclosing function will be inhibited (reclosing function FAIL).

The lockout time TD must be shorter than the programmed TN2 time; this constraint is verified by the protection relay during the set-up and an error message will be displayed if required.

The reclosing function will be also inhibited if one of the protection function operates (TRIP) during **the last programmed reclosing operation** (during TN1 if NRL = 0 or during TN2 if NRL ≥ 1).

The output relay programmed on the auto-reclosing function (ref. F12, paragraph 5.7) will be activated for 100 ms.

The auto-reclosing function will stay inhibited until the protection relay acquires the following signals:

- protection RESET
- switch-gear closing command CHINT

Two of the digital input (6 available) **must be** programmed as:

- switch-gear closing command (CHINT)
- switch-gear opening command (APINT)

Switch-gear closing command - CHINT

When detected by the protection relay (programmed digital input – see 5.8) the switch-gear closing command CHINT will cause the reset of the auto-reclosing function (ready to operate).

The command is managed equivalent to the first reclosure (RR).

Switch-gear opening command - APINT

When detected by the protection relay (programmed digital input - see 5.8) the switch-gear closing command CHINT will cause the **reset and inhibition** of the auto-reclosing

function; the inhibition will stay inhibited until the protection relay acquires a protection RESET command or a switch-gear closing command CHINT.

The following signaling functions can be programmed on output relays:

- successful reclosing function (79 OK)
- failed reclosing function (79 FR)
- reclosing function in progress (79 ON)

When the signaling function 79 OK and 79 FR are active, the related output relays will be activated for 1 sec.; the relay programmed as 79 ON will stay activated during the reclosing function operations.

The status of the last reclosing operation is recorded in the EVENT memory related to the following TRIP condition of the protection relay.

2 FRONT PANEL KEYS

The 5 push-buttons on the front panel allow to visualize all the protection parameters and to modify the protection set-up.



right arrow



down arrow



programming session activation or parameter confirmation



change or increment of the selected parameter



reset of the protection relay (rif. par. 4.3)

VISUALIZATION OF PARAMETERS

- all visualizations are circular and they can be displayed using the two arrow push-buttons.
- the structure of the visualizations and their contents are showed in Fig. 3, 4, 5, 6 and 7.
- when the sealable transparent front panel is installed only the arrow push-buttons and the RESET push-button are accessible to prevent unauthorized modification of the protection set-up.

MODIFICATION OF PARAMETERS

- remove the transparent sealable front panel to access [ENTER] and  push-buttons.

3 FRONT PANEL LED SIGNALING

POWER (green)	⊗ auxiliary supply available
FAIL (red)	⊗ fault condition detected by SELF-DIAGNOSIS software or by PILOT WIRE FAULT MONITORING function
REMOTE (red)	⊗ communication session active on RS485 port
21-67-50 (red)	⊗ trip condition on under-impedance or overcurrent thresholds (directional or NON-directional)
67N-59N (red)	⊗ trip condition on directional earth-fault or residual overvoltage thresholds
FR (red)	⊗ failed reclosing function

The last trip condition (threshold indication) is also showed on front panel display; more information on trip condition are presented in the recorded EVENT (see par. 5.11).

4 PROGRAMMING AND TEST

The protection relay is easily programmable following the instructions in the next paragraphs:

- HOW TO PROGRAM THE PROTECTION RELAY
- HOW TO MODIFY A VISUALIZED PARAMETER

All parameters can be freely modified; the proper protection set-up as required by the plant management is submitted to the operator's judgment.

4.1 How to program the protection relay

The programmable parameters are showed in Figures 3, 4, 5, 6 and 7 at the following references:

B2 ÷ B7	relay address (RS485) and date/time
C1 ÷ C3	protection relay function and insertion
D1 ÷ D9	nominal values, contrast etc.
E1S ÷ E8S	thresholds and time delays ANSI 67 and ANSI 50-51
E1Z ÷ E9Z	thresholds and time delays ANSI 21
E1N ÷ E8N	thresholds and time delays ANSI 67N
E1A ÷ E8A	thresholds and time delays ANSI 67N (EARTH 2)
E1V ÷ E5V	thresholds and time delays ANSI 59N
E1R ÷ E11R	thresholds and time delays ANSI 79
F1 - F14	output relays functions
G1 ÷ G6	digital input functions
H1	special function
R1 ÷ R22	partial trip counters reset

The programming sequence is the following:

- 1) **SELECT** the visualization (on display) of the parameter to be modified using the arrow push-buttons
- 2) **ACTIVATE** the PARAMETER MODIFICATION session depressing the [ENTER] push-button and modify the parameter value
- 3) **END** the parameter modification session depressing again the [ENTER] push-button
- 4) **REPEAT** the procedure from 1) to 3) for all the parameters required to obtain the new protection relay set-up
- 5) **CONFIRM** the new protection relay set-up at the visualization CONFIRM PROG? (Fig. 3, ref. J1) within 5 minutes depressing the push-buttons [ENTER] and  up to visualize **YES** and [ENTER] again to confirm.

NOTE: The protection relay continues to operate using the previous set-up until the new set-up is confirmed as at point 5) above; the visualization of the modified parameters before the new set-up confirmation is only temporary to allow an easy definition of the new protection set-up.

If the new set-up is not confirmed within 5 minutes from the last pressed push-button, the protection relay visualizes again the previous set-up (the parameters set-up that the protection relay is still using).

4.2 How to modify a visualized parameter

When the parameter to be modified is visualized on front panel display do the following sequence:

- 1) **PRESS [ENTER]** to activate the parameter modification session

If one or more parameters are modifiable, on the first of them will appear a blinking cursor.

If no parameters are modifiable, no blinking cursor will appear.

- 2) **MODIFY THE PARAMETER** pressing the arrow push-buttons and 



when two parameters are modifiable, the push-button allows to point-out the parameter to be modified (the selected parameter will blink)



when numerical parameters are pointed-out the push-button allows to select the digit to be modified



increasing of the parameter

a) the digits are increased by 1 unit

b) the other parameters are presented following the selection list

- 3) **PRESS [ENTER]** to end parameter modification session

The modification session is ended and the parameter stops to blink

NOTE: if a numerical parameter is selected out of the accepted range (as shown in Table A) when the push-button [ENTER] is pressed for few seconds an error message will be displayed as:

Data Error

and the parameter will be displayed again with the former value.

4.3 Reset

When the push-button [RESET] is pressed, the protection relays returns to the standard condition:

- reset of glowing LED's
- drop-off of tripped relays
- reset of any parameter changed but not confirmed (parameters are shown as confirmed at the end of the last programming session)
- display on STANDARD MODE (Fig. 3, ref. A1 - par. 5.1)

4.4 Test of output relays

When the output relays test is selected (Fig. 5, ref. F14) it is possible to command an output relay (one at the time) to trip from the current status allowing functional tests on electrical plants.

The output relays are activated with the following sequence:

- 1) **SELECT THE VISUALIZATION** of the desired output relay to be tested

TEST R1 OFF

- 2) **PRESS [ENTER]** to activate the test session; the message OFF will start to blink.
- 3) **PRESS**  and the message on the display will change as:

TEST R1 ON

- 4) **PRESS [ENTER]** to command the instantaneous trip of the output relay (change of the current status).

The relay will stay on the new condition until:

- the  or **[RESET]** push-button is pressed
- the **[ENTER]** push-button is pressed and the sequence at points 3 and 4 is repeated (presenting OFF condition)

The same procedure will be used for R2, R3 and R4 relays.

5 DISPLAY AND PROGRAMMING

The contents and the structure of the displayed messages are shown in figures 3÷7; the references A1, B1, B2 etc. identify specific displayed messages in the figures.

5.1 Standard display (fig. 3)

A1 - STANDARD DISPLAY (fig. 3)

It is the standard displayed message without operator's intervention (no push-buttons pressed for at least 5 minutes) or when the RESET push-button has been pressed.

The displayed information is function of the protection relay status.

NORMAL FUNCTIONING

During this state the following information can be visualized (as defined by set-up):

- **Protection function (ANSI code)** - the display shows the ANSI codes of the main selectable functions (ref. C1 - FUNCTION SELECTION)
- **Measured parameters** - the display shows one of the measures (current, voltage, impedance etc.) or the auto-reclosing status.

The measure is visualized as primary values.

ON TRIP CONDITION

When a trip condition occurs the protection relay visualizes the TRIP message that includes the threshold related to the trip; the displayed messages are as the following:

TRIP S1	TRIP NS2	TRIP Z1	TRIP Uo>>
------------	-------------	------------	--------------

The information of the trip, as well the glowing of the related LED's, is displayed until the [RESET] push-button is pressed.

If a new trip condition occurs, the displayed information will be updated; information related to previous trips are recorded in EVENTS memory.

When the auto-reclosing function (ANSI 79 status) is selected during the operation the following messages will be displayed:

ON	auto-reclosing function programmed
OF	auto-reclosing function inhibited (not programmed)
OF DIG	auto-reclosing function temporary inhibited by external command (digital input)
IN CORSO	auto-reclosing function in progress
FAIL RIC	failed auto-reclosing function

FAULT CONDITION

When a permanent or temporary fault condition is detected by the self-diagnosis module, the following message will be displayed:

FAIL eeeeeeee

The string eeeeeeee can be:

- F.PILOT Detected fault condition on pilot wire; the function related to DIG1 digital input is suspended
Corrective action - verify pilot wire (short or open circuit)
- HARDWARE Detected fault condition on hardware or software resources of the protection relay; all functions are suspended.
Corrective action - replace the protection relay and contact Seb post sales service

5.2 Visualization structure

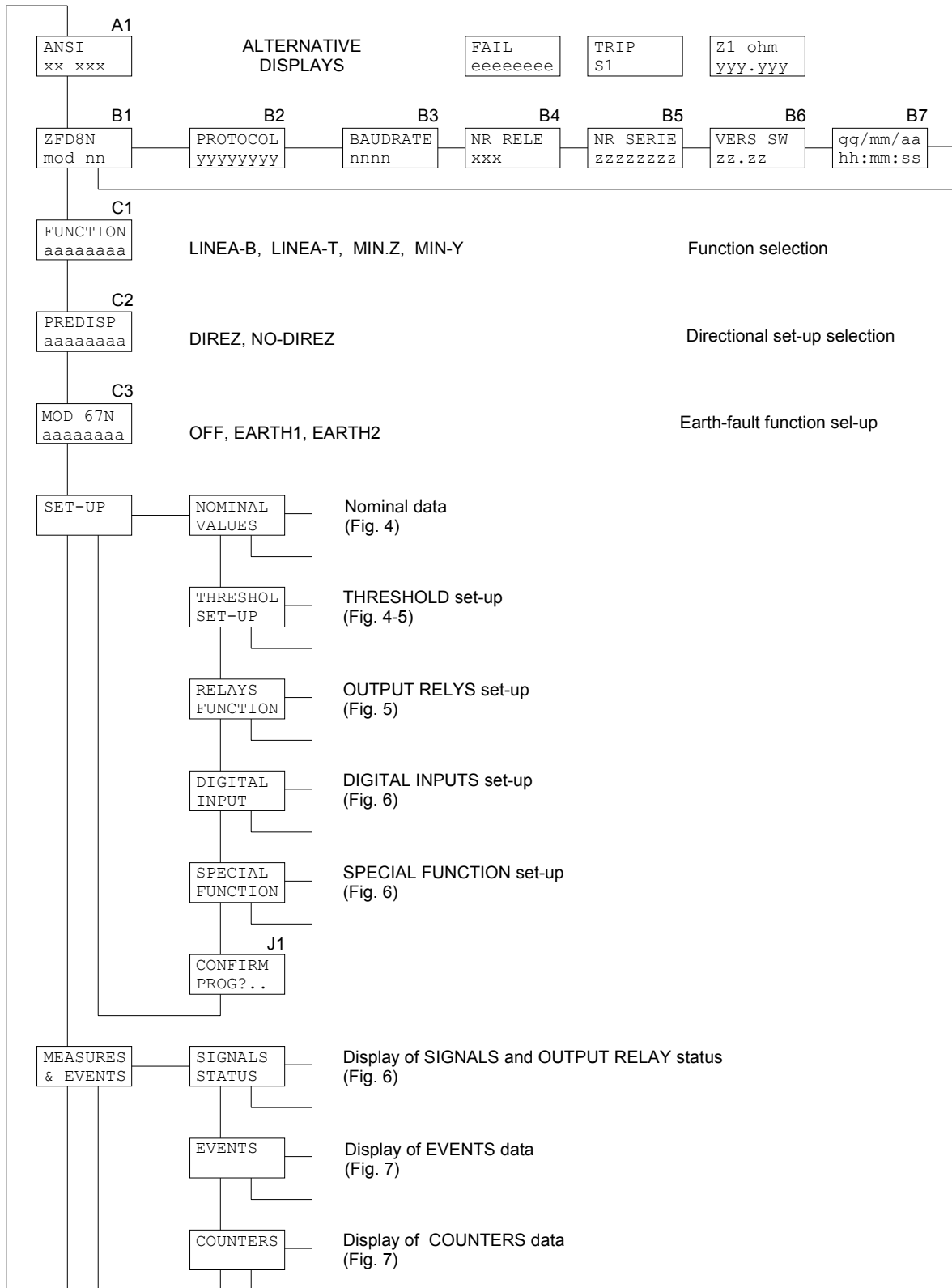

Figure 3

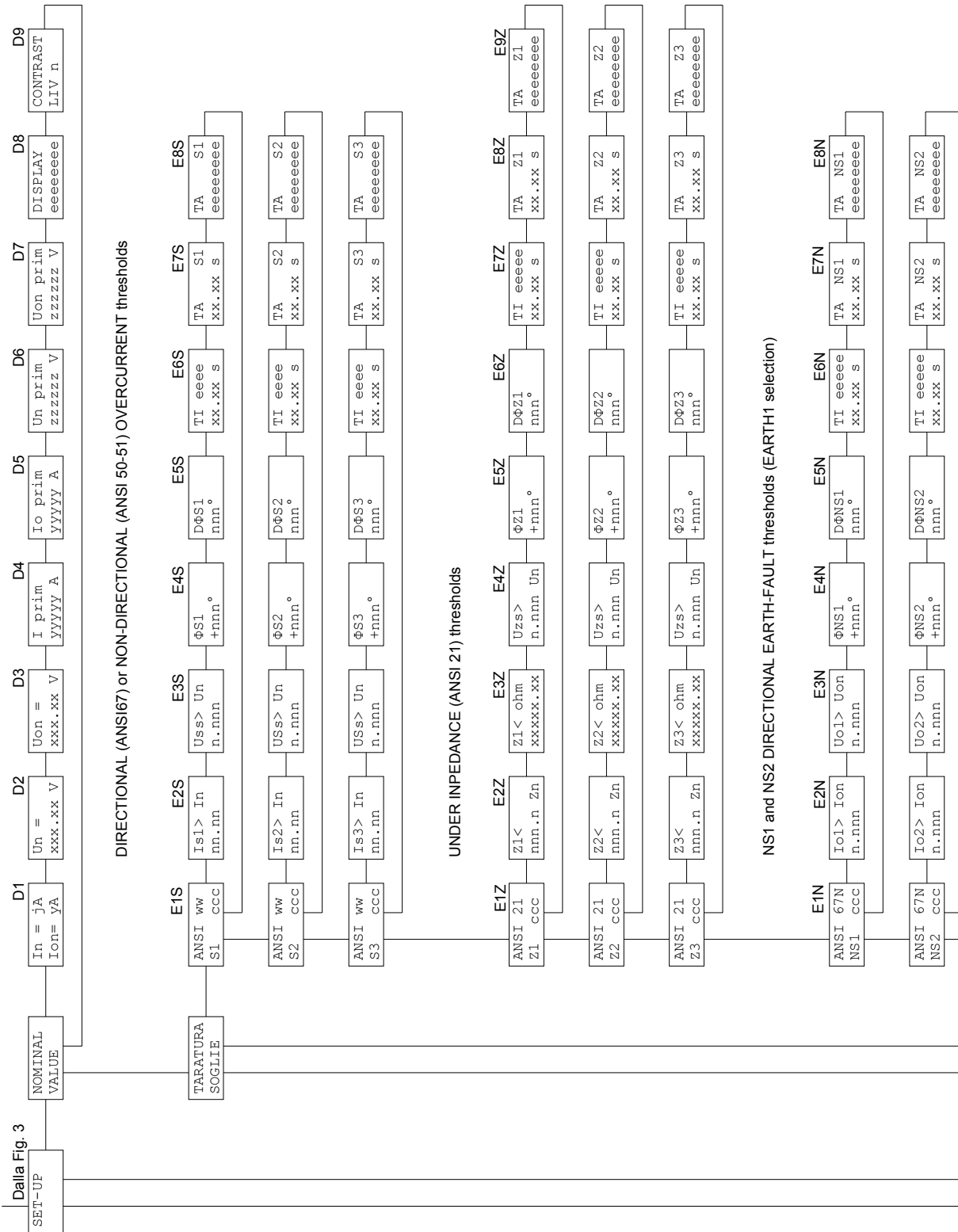

Figure 4

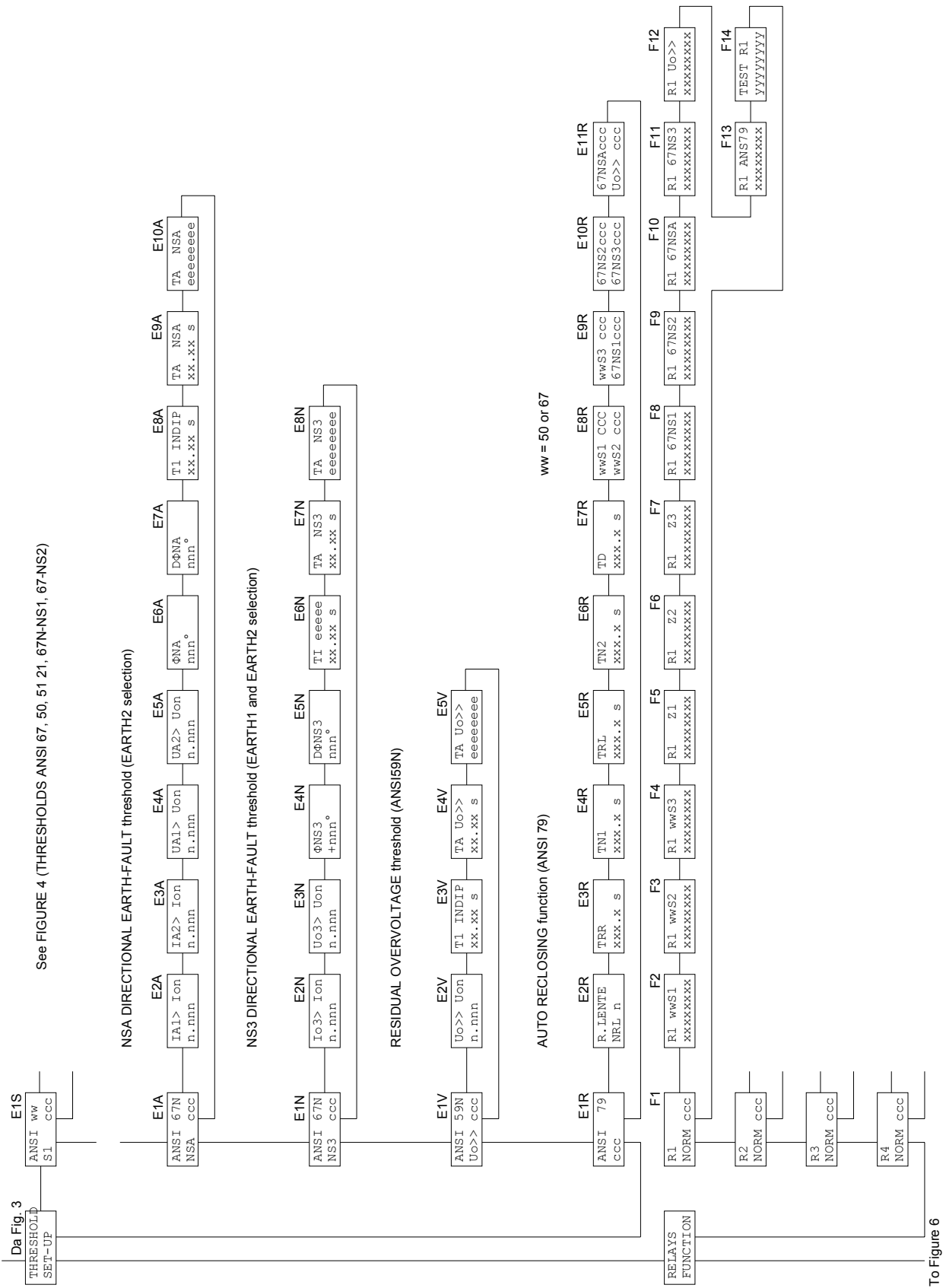

Figure 5

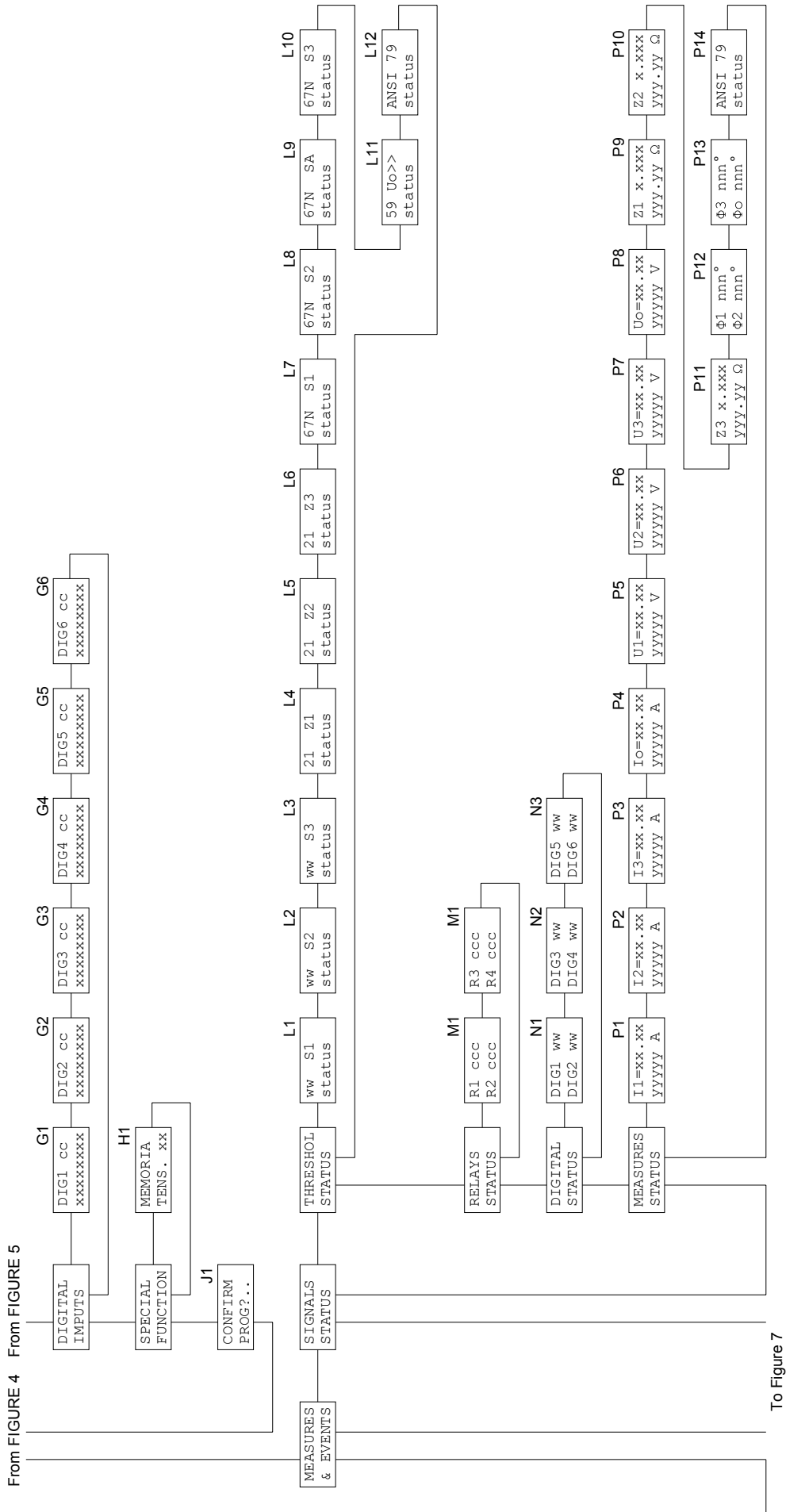

Figure 6

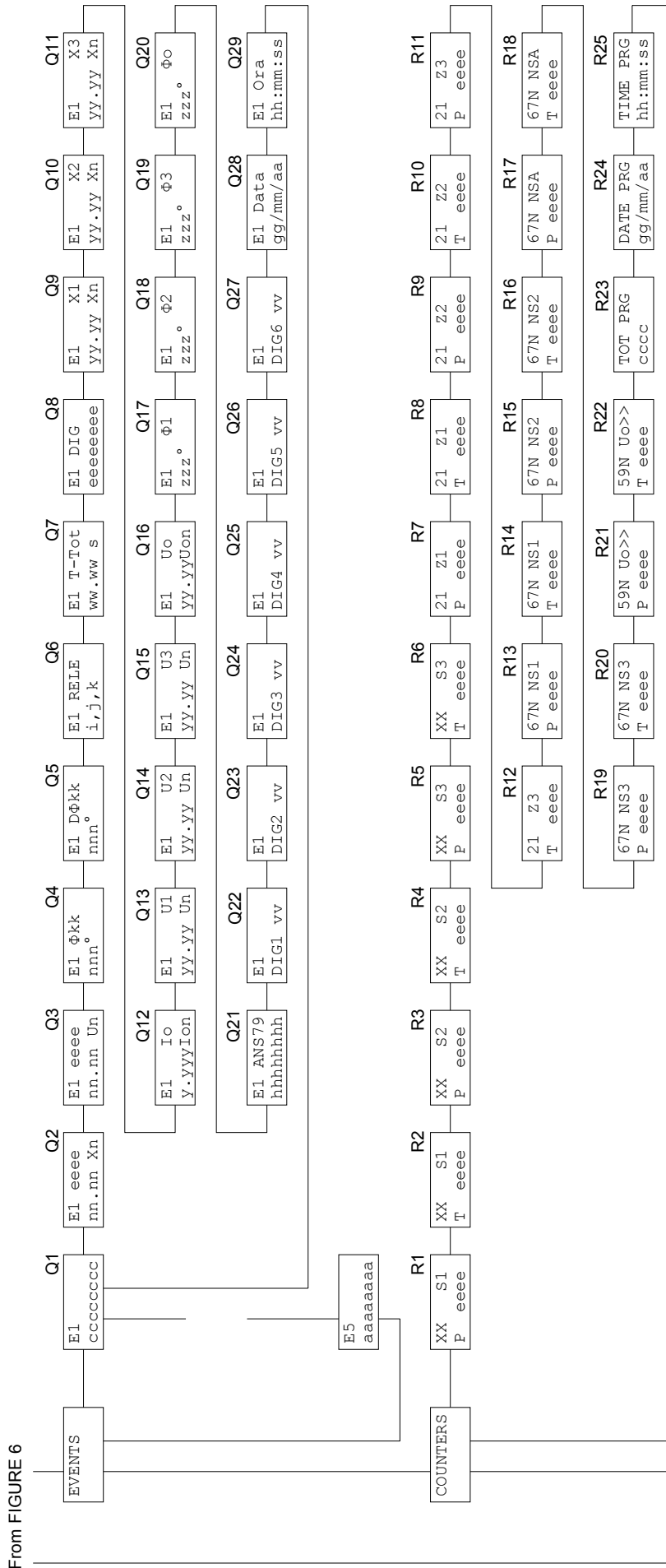

Figure 7

5.3 Address and time (fig. 3)

B1 - RELAY MODEL (not programmable)

```
ZFD8N
mod. nn
```

Models A5 (nominal earth fault current $I_{on} = 5$ A)
 A1 (nominal earth fault current $I_{on} = 1$ A)

The nominal phase current is programmable 1 A or 5 A

B2 - B3 - COMMUNICATION PROTOCOL (programmable)

B2

```
PROTOCOL
xxxxxxxx
```

The communication protocol is programmable between the followings:

STANDARD	ASCII Seb protocol
MODBUS	Modbus protocol (SLAVE)

When the MODBUS protocol is selected the following display is showed to allow the selection of the transmission speed:

B3

```
BAUDRATE
xxxx
```

The xxxx parameter is selectable between the followings:

300 - 600 - 1200 - 2400 - 4800 - 9600

When the STANDARD protocol is selected the baud rate is automatically selected by the protection relay.

B4 - ADDRESS (programmable)

```
NR RELAY
001
```

Programmable address from 001 to 255.

The number is used on RS485 port to address a specific relay when two or more protection relays are linked on the same serial line.

B5 - RELAY SERIAL NUMBER (not programmable)

```
SER. NR
0012345
```

B6 - SOFTWARE REVISION LEVEL (not programmable)

SW REV
zz.zz

B7 - TIME / DATE (programmable)

dd/mm/yy
hh:mm:ss

Time and date are programmable and they are used to mark recorded events.

NOTE the clock is not provided with back-up battery, therefore a loss of auxiliary supply will force time/date to the following condition:

01/01/90
00:00:00

5.4 Function selection (fig. 3)**C1 - FUNCTION SELECTION (programmable)**

FUNCTION
xxxxxxxx

The selection of the function performed by the protection relay defines the available thresholds.

FUNCTION	ANSI	SELECTION	AVAILABLE THRESHOLDS
2-phase overcurrent (directional or non-directional)	67 50 - 51	2 PHASE	S1, S2, S3
3-phase overcurrent (directional or non-directional)	67 50 - 51	3 PHASE	S1, S2, S3
Under-impedance using phase to phase voltages (directional or non-directional)	21	MIN Z-D	Z1, Z2, Z3
Under-impedance using phase to earth voltages (directional or non-directional)	21	MIN Z-Y	Z1, Z2, Z3

The directional earth-fault function (67N - thresholds NS1, NS2, NS3 and NSA) and the residual overvoltage function (59N - threshold $U_{o>>}$) are always available.

Examples:

FUNCTION
2-PHASE

FUNCTION
3-PHASE

FUNCTION
MIN Z-Y

C2 - SET-UP DIRECTIONAL OPERATIONS (programmable)

```
SET DIR
xxxxxxx
```

The set-up of the directional operations allows to select the DIRECTIONAL or NON-DIRECTIONAL operating of the overcurrent thresholds (ANSI 67 or ANSI 50-51) or under-impedance thresholds (ANSI 21) as selected at ref. C1.

The NON-DIRECTIONAL OPERATION of only one threshold can also be obtained programming the sector width equals to 180° (see paragraph 1.1).

OPERATION	SELECTION	ANSI
Directional operation	DIREZ	67 when selected 2-PHASE or 3-PHASE 21 when selected MIN Z-D or MIN Z-Y
NON directional operation	NO-DIREZ	50 - 51 when selected 2-PHASE or 3-PHASE 21 when selected MIN Z-D or MIN Z-Y

Examples:

```
SET DIR
DIREZ
```

```
SET DIR
NO-DIREZ
```

C3 - EARTH-FAULT MODE SELECTION (programmable)

```
MOD 67N
xxxxxxx
```

It allows to define the operation mode of the directional earth-fault thresholds (ANSI 67N - see paragraph 1.4 and 1.4.1); the following selections are available:

EARTH-FAULT MODE	ANSI	SELECTION	AVAILABLE THRESHOLDS
Directional earth-fault thresholds (67N) and residual overvoltage threshold (59N) INHIBITED	-	OFF	NONE
Directional earth-fault with 3 independent thresholds	67 N	EARTH 1	NS1, NS2, NS3, Uo>>
Directional earth-fault with NON operating zone	67 N	EARTH 2	NSA, NS3, Uo>>

Examples:

MOD 67N
EARTH 1

MOD 67N
OFF

MOD 67N
EARTH 2

5.5 Nominal values set-up (fig. 4)

D1 - NOMINAL CURRENT SELECTION I_n (programmable)

$I_n = x \text{ A}$
$I_{on} = 1 \text{ A}$

$I_n = x \text{ A}$
$I_{on} = 5 \text{ A}$

I_n nominal phase current programmable 1 A or 5 A

I_{on} nominal earth current (defined by models - manufacturer set-up)

$I_{on} = 5 \text{ A}$ ZFD8N model A5 - see ref. B1

$I_{on} = 1 \text{ A}$ ZFD8N model A1 - see ref. B1

D2 - D3 - NOMINAL VOLTAGE SELECTION - U_n and U_{on} (programmable)

D2

$U_n =$
xxx.xx V

D3

$U_{on} =$
xxx.xx V

U_n nominal line voltage selection (nominal secondary voltage of plant VT's)

U_{on} nominal residual voltage selection (nominal secondary residual voltage VT)

selectable between the followings:

57.73 - 63.50 - 72.16 - 100 - 110 - 125 - 190 - 220 - 230 - 380 - 400

D4 - D5 - PRIMARY PHASE AND EARTH CURRENT (programmable)

D4

$I_n \text{ prim}$
xxxxxx A

D5

$I_{on} \text{ prim}$
xxxxxx A

$I_n \text{ prim}$ primary phase current value of the installed phase CT's.

$I_{on} \text{ prim}$ primary current value of the installed earth CT's.

The values are programmable from 0001 to 18500 A.

NOTE: when Holmgreen insertion is used, select $I_{on} \text{ prim} = I_n \text{ prim}$.

D6 - D7 - PRIMARY VT's VOLTAGES (programmable)

D6

$U_n \text{ prim}$
xxxxxxx V

D7

$U_{on} \text{ prim}$
xxxxxxx V

$U_n \text{ prim}$ primary voltage value of the installed line VT's.

Uon prim primary voltage value of the installed residual VT's.

The values are programmable from 000001 to 999999 V.

D8 - STANDARD DISPLAY SELECTION (programmable)

DISPLAY eeeeeeee

It allows to select the standard displayed information (ref. A1) when no trip condition occurs and no fault condition has been detected by the self-diagnosis module; the available selections are the following:

SELECTION	DISPLAY	SELECTION	DISPLAY
ANSI	ANSI code of the available functions	STATO 79	Auto-reclosing function status
I1	Current I1	PHASE1	Angle U1-I1
I2	Current I2	PHASE2	Angle U2-I2
I3	Current I3	PHASE3	Angle U3-I3
Io	Current Io	PHASEo	Angle Uo-Io
U1	Voltage U1	Z1	Impedance Z1
U2	Voltage U2	Z2	Impedance Z2
U3	Voltage U3	Z3	Impedance Z3
Uo	Voltage Uo		

The presented selection are coherent with the functions selected at ref. C1, C2 and C3 (e.g. when selected 2-PHASE the impedance selection will not be presented).

Examples:

DISPLAY ANSI

DISPLAY Uo

DISPLAY Z1

D9 - DISPLAY CONTRAST LEVEL (programmable)

CONTRAST LIV x

The display contrast level is programmable from 0 to 9. The backlighted display is switched off if no push-button is pressed for at least 5 minutes; when one of the front panel push - button is pressed the display is switched on.

5.6 Thresholds and time delays set-up (fig. 4)

Only the thresholds enabled at the FUNCTION SELECTION (ref. C1) and EARTH-FAULT MODE SELECTION (C3) are presented.

Selection	2-PHASE - 3-PHASE	thresholds S1, S2, S3 (ref. 5.6.15.4.1)	
Selection	MIN Z-Y - MIN Z-D	thresholds Z1, Z2, Z3 (ref. 5.6.25.4.2)	
Selection	EARTH 1	thresholds NS1, NS2, NS3, Uo>>	(ref 5.6.3 - 5.6.5)
Selection	EARTH 2	thresholds NSA, NS3, Uo>>	(ref 5.6.3 - 5.6.4 - 5.6.5)

5.6.1 ANSI 67 thresholds programming (fig. 4)

The information and set-ups related to threshold **S1** in the following points are effective for the thresholds **S2** and **S3** (if not specifically written) just taking into consideration the change of the threshold identification.

The available settings for each threshold are listed in Table A.

E1S - ON / OFF THRESHOLD (programmable)

```
ANSI  ww
S1   ccc
```

ww ANSI code related to the threshold (see selection C2 - par. 5.4)
 67 selection DIREZ
 50 selection NO-DIREZ

ccc ON - enabled threshold
 OFF - disabled threshold (available but not active)

E2S - CURRENT THRESHOLD LEVEL SET-UP (programmable)

```
Is1> In
nn.nn
```

nn.nn threshold level referred to the current nominal value (In)

Examples:

```
Is1> In
01.50
```

```
Is2> In
02.00
```

```
Is3> In
03.50
```

E3S - VOLTAGE THRESHOLD LEVEL SET-UP (programmable)

The voltage threshold level programming is presented only when the directional operation has been selected (selection DIREZ - par. 5.4, ref. C2).

```
USs> Un
n.nnn
```

n.nnn threshold level referred to the voltage nominal value (Un)

Examples:

```
USs> Un
0.050
```

```
USs> Un
0.200
```

It is suggested to program the overvoltage threshold **USs>** (common to the 3 directional overcurrent thresholds) at the minimum value allowed by the installation characteristics to obtain the relay operates independently from the voltage level; it is suggested to avoid to program the threshold **USs>** lower than 1 V (VT secondary value).

When the measured voltage is lower than the threshold the voltage memory function (if enabled) will be activated (see par. 1.2 and par. 5.9 - ref. H1)

Note: the voltage threshold is programmable only at S1 threshold set-up; at S2 and S3 thresholds set-ups the voltage value is presented but it is not programmable.

E4S - CHARACTERISTIC ANGLE SET-UP (programmable)

The programming of the characteristic angle is presented only if the directional operation has been selected (selection DIREZ - par. 5.4, ref. C2)

$\Phi S1$
$\pm \text{nnn}^\circ$

$\pm \text{nnn}^\circ$ programmable from -180° to $+180^\circ$

The characteristic angle is defined with the measured voltage as reference (see paragraph 1.1).

Examples:

$\Phi S1$
$+090^\circ$

$\Phi S2$
-075°

Please use the down arrow push-button to select the sign or the digit to be modified.

E5S - SECTOR WIDTH SET-UP (programmable)

The programming of the sector width is presented only if the directional operation has been selected (selection DIREZ - par. 5.4, ref. C2)

$D\Phi S1$
nnn°

nnn° programmable from 015° to 180°

It represents the width of the angular sector (see paragraph 1.1)

Examples:

$D\Phi S1$
090°

$D\Phi S3$
180°

NOTE: When a sector width **DΦSx** is defined equal to 180° the related overcurrent threshold **Sx** becomes NON-directional (ANSI 50-51) and the overvoltage threshold **USs>** will be indifferent.

E6S - TIME DELAY SET-UP (programmable)

TI eeeee
xx.xx s

Set-up of the time-delay to the activation (TRIP) of the programmed output relays when the directional thresholds operates.

Parameter TI eeeee: time delay characteristic

For the **S1** threshold the time delay can be selected between one of the followings:

INDIP	definite time delay
DIP=A	time delay as curve A IEC 255-4 (inverse time)
DIP=B	time delay as curve B IEC 255-4 (very inverse time)
DIP=C	time delay as curve C IEC 255-4 (extremely inverse time)

For the thresholds **S2** and **S3** the TI parameter is fixed as INDIP (definite time)

Parameter xx.xx:

Time definite - time delay (seconds) to activate the programmed output relays: the output relay trips when the measured current exceeds the threshold level (programmable from 00.02 to 99.99 s).

Time dependent - value of the parameter K (see formulas paragraph 7).

TI DIP=B
02.50 K

TI DIP=A
10.00 K

TI INDIP
03.25 s

NOTE: the index K or s is shown coherently to the selected time-delay characteristic when the push-button [ENTER] is pressed.

E7S - ADDITIONAL TIME DELAY SET-UP (programmable)

TA S1
xx.xx s

The selection is displayed only when a TIME DEFINITE characteristic has been selected (TI INDIP at ref. E6S); when TIME DEPENDENT characteristic has been programmed, the selection will not be displayed.

The additional time delay TA is programmable from 00.00 to 99.99 seconds; please note that at least one of the digital inputs should be programmed to activate the time delay function (ref. G1 ÷ G6 - paragraph 5.8).

The additional time delay TA is added to the time delay TI to obtain the output relay trip when the TI+TA time expires.

The additional time delay TA will be added if the time delay TI is programmed at least equals to 50 ms (digital input acquisition time - 40 ms)

E8S - DIGITAL INPUT ACTIVE ON THRESHOLD (non programmable)

TA	S1
eeeeeeee	

It shows the digital input programmed to activate the additional time delay TA on the displayed threshold.

The parameter eeeeeeee can show one of the following values:

DISABLED	none of the digital inputs has been programmed to activate an additional time delay related to the threshold S1
DIG1	digital input DIG1 activates the TA delay on threshold S1
DIG2	digital input DIG2 activates the TA delay on threshold S1
DIG3	digital input DIG3 activates the TA delay on threshold S1
DIG4	digital input DIG4 activates the TA delay on threshold S1
DIG5	digital input DIG5 activates the TA delay on threshold S1
DIG6	digital input DIG6 activates the TA delay on threshold S1

When a TIME DEPENDENT characteristic threshold has been programmed the visualization is omitted as no additional time delays can be defined and programmed on time dependent delays.

More than one digital input can activate the same additional time delay (e.g. DIG 1,3).

Please note that to activate the additional time delay at least one of the digital inputs should be programmed (ref. G1 ÷ G6 - paragraph 5.8).

5.6.2 ANSI 21 thresholds programming - (fig. 4)

The information and set-ups related to threshold **Z1** in the following points are effective for the thresholds **Z2** and **Z3** (if not specifically written) just taking into consideration the change of the threshold identification.

The available settings for each threshold are listed in Table A.

E1Z - ON / OFF THRESHOLD (programmable)

ANSI	21
Z1	ccc

ccc ON - enabled threshold
OFF - disabled threshold (available but not active)

E2Z - UNDER-IMPEDANCE THRESHOLD LEVEL SET-UP (programmable)

Z1<	Zn
n.nnn	

n.nnn threshold level referred to the impedance nominal value (Zn)

Examples:

Z1< Zn
0.550

Z2< Zn
2.150

Z3< Zn
3.500

E3Z - UNDER-IMPEDANCE THRESHOLD VISUALIZATION IN OHM (non programmable)

Z1< Ohm
xxxx.xx

xxxx.xx threshold level presented as Ohm (primary values) (see par. 1.6)

E4Z - VOLTAGE THRESHOLD LEVEL SET-UP (programmable)

The voltage threshold level programming is presented only when the directional operation has been selected (selection DIREZ - par. 5.4, ref. C2)

UZs> Un
n.nnn

n.nnn threshold level referred to the voltage nominal value (Un)

Examples:

UZs> Un
0.050

UZs> Un
0.200

It is suggested to program the overvoltage threshold **UZs>** (common to the 3 thresholds) at the minimum value allowed by the installation characteristics to obtain the relay operates independently from the voltage level; it is suggested to avoid to program the threshold **UZs>** lower than 1 V (VT secondary value)

When the measured voltage is lower than the threshold the voltage memory function (if enabled) will be activated (see par. 1.2 and par. 5.9 - ref. H1).

Note: the voltage threshold is programmable only at Z1 threshold set-up; at Z2 and Z3 thresholds set-ups the voltage value is presented but it is not programmable.

E5Z - CHARACTERISTIC ANGLE SET-UP (programmable)

The programming of the characteristic angle is presented only if the directional operation has been selected (selection DIREZ - par. 5.4, ref. C2)

ΦZ1
± nnn°

±nnn° programmable from -180° to +180°

The characteristic angle is defined with the measured voltage as reference (see paragraph 1.1)

Examples:

$\Phi Z1$ +090°

$\Phi Z2$ -075°

Please use the down arrow push-button to **select the sign or the digit** to be modified.

E6Z - SECTOR WIDTH SET-UP (programmable)

The programming of the sector width is presented only if the directional operation has been selected (selection DIREZ - par. 5.4, ref. C2)

D $\Phi Z1$ nnn°

nnn° programmable from 015° to 180°

It represents the width of the angular sector (see paragraph 1.1).

Examples:

D $\Phi Z1$ 090°

D $\Phi Z3$ 180°

NOTE When a sector width **D ΦZx** is defined equal to 180° the related under-impedance threshold **Zx** becomes NON-directional and the overvoltage threshold **UZs>** will be indifferent.

E7Z - TIME DELAY SET-UP (programmable)

TI INDIP xx.xx s

Set-up of the time-delay to the activation (TRIP) of the programmed output relays when the thresholds operates; the available time delay is definite time only.

E8Z - ADDITIONAL TIME DELAY SET-UP (programmable)

TA Z1 xx.xx s

The additional time delay TA is programmable from 00.00 to 99.99 seconds; please note that at least one of the digital inputs should be programmed to activate the time delay function (ref. G1 ÷ G6 - paragraph 5.8).

The additional time delay TA is added to the time delay TI to obtain the output relay trip when the TI+TA time expires.

The additional time delay TA will be added if the time delay TI is programmed at least equals to 50 ms (digital input acquisition time - 40 ms)

E9Z - DIGITAL INPUT ACTIVE ON THRESHOLD (not programmable)

TA Z1 eeeeeee

It shows the digital input programmed to activate the additional time delay TA on the displayed threshold.

The parameter eeeeeeee can show one of the following values:

DISABLED	none of the digital inputs has been programmed to activate an additional time delay related to the threshold Z1
DIG1	digital input DIG1 activates the TA delay on threshold Z1
DIG2	digital input DIG2 activates the TA delay on threshold Z1
DIG3	digital input DIG3 activates the TA delay on threshold Z1
DIG4	digital input DIG4 activates the TA delay on threshold Z1
DIG5	digital input DIG5 activates the TA delay on threshold Z1
DIG6	digital input DIG6 activates the TA delay on threshold Z1

More than one digital input can activate the same additional time delay (e.g. DIG 1,3).

Please note that to activate the additional time delay at least one of the digital inputs should be programmed (ref. G1 ÷ G6 - paragraph 5.8).

5.6.3 ANSI 67N thresholds programming - (fig. 4 and fig. 5)

The information and set-ups related to threshold **NS1** in the following points are effective for the thresholds **NS2** and **NS3** (if not specifically written) just taking into consideration the change of the threshold identification.

The available settings for each threshold are listed in Table A.

E1N - ON / OFF THRESHOLD (programmable)

```
ANSI 67N
NS1 ccc
```

ccc ON - enabled threshold
OFF - disabled threshold (available but not active)

E2N - CURRENT THRESHOLD LEVEL SET-UP (programmable)

```
Io1> Ion
n.nnn
```

n.nnn threshold level referred to the current nominal value (Ion)

Examples:

```
Io1> Ion
0.850
```

```
Io2> Ion
2.000
```

```
Io3> Ion
3.500
```

E3N - OVERVOLTAGE THRESHOLD LEVEL SET-UP (programmable)

NS1 threshold voltage level programming.

```
Uo1> Uon
n.nnn
```

n.nnn threshold level referred to the voltage nominal value (Uon)

Examples:

```
Uo1> Uon
0.050
```

```
Uo3> Uon
0.200
```

Note: the overvoltage threshold is independently programmable for each threshold **NS1**, **NS2** and **NS3**.

E4N - CHARACTERISTIC ANGLE SET-UP (programmable)

```
ΦN1
± nnn°
```

±nnn° programmable from -180° to +180°

The characteristic angle is defined with the measured voltage as reference (see paragraph 1.1).

Examples:

```
ΦN1
+090°
```

```
ΦN2
-075°
```

Please use the down arrow push-button to **select the sign or the digit** to be modified.

E5N - SECTOR WIDTH SET-UP (programmable)

```
DΦN1
nnn°
```

nnn° programmable from 015° to 180°

It represents the width of the angular sector (see paragraph 1.1).

Examples:

```
DΦN1
090°
```

```
DΦN3
180°
```

NOTE: When a sector width **DΦNx** is defined equal to 180° the related overcurrent threshold **NSx** becomes non-directional and the related overvoltage threshold **Uo1>**, **Uo2>** and **Uo3>** will be indifferent

E6N - TIME DELAY SET-UP (programmable)

```
TI eeeee
xx.xx s
```

Set-up of the time-delay to the activation (TRIP) of the programmed output relays when the directional thresholds operates.

Parameter TI eeeee: time delay characteristic

For the **NS1** threshold the time delay can be selected between one of the followings:

INDIP	definite time delay
DIP=A	time delay as curve A IEC 255-4 (inverse time)
DIP=B	time delay as curve B IEC 255-4 (very inverse time)
DIP=C	time delay as curve C IEC 255-4 (extremely inverse time)

For the thresholds **NS2** and **NS3** the TI parameter is fixed as INDIP (definite time).

Parameter xx.xx:

Time definite - time delay (seconds) to activate the programmed output relays: the output relay trips when the measured current exceeds the threshold level (programmable from 00.02 to 99.99 s).

Time dependent - value of the parameter K (see formulas paragraph 7).

TI DIP=B 02.50 K	TI DIP=A 10.00 K	TI INDIP 03.25 s
---------------------	---------------------	---------------------

NOTE: the index K or s is shown coherently to the selected time-delay characteristic when the push-button [ENTER] is pressed.

E7N - ADDITIONAL TIME DELAY SET-UP (programmable)

TA NS1 xx.xx s

The selection is displayed only when a TIME DEFINITE characteristic has been selected (TI INDIP at ref. E6N); when TIME DEPENDENT characteristic has been programmed, the selection will not be displayed.

The additional time delay TA is programmable from 00.00 to 99.99 seconds; please note that at least one of the digital inputs should be programmed to activate the time delay function (ref. G1 ÷ G6 - paragraph 5.8).

The additional time delay TA is added to the time delay TI to obtain the output relay trip when the TI+TA time expires.

The additional time delay TA will be added if the time delay TI is programmed at least equals to 50 ms (digital input acquisition time - 40 ms)

E8S - DIGITAL INPUT ACTIVE ON THRESHOLD (not programmable)

TA NS1 eeeeeee

It shows the digital input programmed to activate the additional time delay TA on the displayed threshold.

The parameter eeeeeeee can show one of the following values:

DISABLED	none of the digital inputs has been programmed to activate an additional time delay related to the threshold NS1
DIG1	digital input DIG1 activates the TA delay on threshold NS1
DIG2	digital input DIG2 activates the TA delay on threshold NS1
DIG3	digital input DIG3 activates the TA delay on threshold NS1
DIG4	digital input DIG4 activates the TA delay on threshold NS1
DIG5	digital input DIG5 activates the TA delay on threshold NS1
DIG6	digital input DIG6 activates the TA delay on threshold NS1

When a TIME DEPENDENT characteristic threshold has been programmed the visualization is omitted as no additional time delays can be defined and programmed on time dependent delays.

More than one digital input can activate the same additional time delay (e.g. DIG 1,3).

Please note that to activate the additional time delay at least one of the digital inputs should be programmed (ref. G1 ÷ G6 - paragraph 5.8).

5.6.4 ANSI 67N threshold SA programming - (fig. 5)

E1A - ON / OFF THRESHOLD (programmable)

ANSI 67N
NSA ccc

ccc ON - enabled threshold
OFF - disabled threshold (available but not active)

E2A - E3A - CURRENT THRESHOLDS LEVEL SET-UP (programmable)

E2A	E3A
IA1> Ion n.nnn	IA2> Ion n.nnn

n.nnn threshold level referred to the current nominal value (Ion)

Examples:

IA1> 0.050 In	IA2> 0.100 In
------------------	------------------

NOTE: The threshold level **IA2>** must be greater or equal to the threshold level **IA1>**; if the condition is not verified, an error message will be displayed.

E4A - E5A - OVERVOLTAGE THRESHOLDS LEVEL SET-UP (programmable)

E4A	E5A
UA1> Uon n.nnn	UA2> Uon n.nnn

n.nnn threshold level referred to the voltage nominal value (Uon)

Examples:

UA1> Uon 0.500	UA2> Uon 0.100
-------------------	-------------------

NOTE: The threshold level UA1> must be greater or equal to the threshold level UA2>; if the condition is not verified, an error message will be displayed.

E6A - CHARACTERISTIC ANGLE SET-UP (programmable)

Φ_{NA} \pm nnn°

\pm nnn° programmable from -180° to +180°

The characteristic angle is defined with the measured voltage as reference (see paragraph 1.1).

Examples:

Φ_{NA} +090°	Φ_{NA} -075°
----------------------	----------------------

Please use the down arrow push-button to **select the sign or the digit** to be modified.

E7A - SECTOR WIDTH SET-UP (programmable)

$D\Phi_{NA}$ nnn°

nnn° programmable from 015° to 180°

It represents the width of the angular sector (see paragraph 1.1).

Examples:

$D\Phi_{NA}$ 090°	$D\Phi_{NA}$ 180°
----------------------	----------------------

NOTE: When a sector width **$D\Phi_{NA}$** is defined equal to 180° the related overcurrent threshold **NSA** becomes NON - directional and the overvoltage thresholds **UA1>** and **UA2>** will be indifferent. As consequence is suggested to set-up the threshold **NS3** as NON - directional threshold using the functional mode EARTH 1 instead of using the **NSA** threshold.

E8A - TIME DELAY SET-UP (programmable)

TI INDIP
xx.xx s

Set-up of time-delay to the activation (TRIP) of the programmed output relays when the directional threshold NSA operates. The time delay is programmable from 00.02 to 99.99 s.

Example:

TI INDIP
01.50 s

E9A - ADDITIONAL TIME DELAY SET-UP (programmable)

TA NSA
xx.xx s

The additional time delay TA is programmable from 00.00 to 99.99 seconds; please note that at least one of the digital inputs should be programmed to activate the time delay function (ref. G1 ÷ G6 - paragraph 5.8).

The additional time delay TA is added to the time delay TI to obtain the output relay trip when the TI+TA time expires.

The additional time delay TA will be added if the time delay TI is programmed at least equals to 50 ms (digital input acquisition time - 40 ms)

E10A - DIGITAL INPUT ACTIVE ON THRESHOLD (not programmable)

TA NSA
eeeeeee

It shows the digital input programmed to activate the additional time delay TA on the displayed threshold.

The parameter eeeeeeee can show one of the following values:

DISABLED	none of the digital inputs has been programmed to activate an additional time delay related to the threshold NSA
DIG1	digital input DIG1 activates the TA delay on threshold NSA
DIG2	digital input DIG2 activates the TA delay on threshold NSA
DIG3	digital input DIG3 activates the TA delay on threshold NSA
DIG4	digital input DIG4 activates the TA delay on threshold NSA
DIG5	digital input DIG5 activates the TA delay on threshold NSA
DIG6	digital input DIG6 activates the TA delay on threshold NSA

More than one digital input can activate the same additional time delay (e.g. DIG 1,3).

Please note that to activate the additional time delay at least one of the digital inputs should be programmed (ref. G1 ÷ G6 - paragraph 5.8).

5.6.5 ANSI 59N threshold Uo>> programming - (fig. 5)

The available settings for each threshold are listed in Table A.

E1V - ON / OFF THRESHOLD (programmable)

```
ANSI 59N
Uo>> ccc
```

ccc ON - enabled threshold
OFF - disabled threshold (available but not active)

E2V - VOLTAGE THRESHOLD LEVEL SET-UP (programmable)

```
Uo>> Uon
n.nnn
```

n.nnn threshold level referred to the voltage nominal value (Uon)

Examples:

```
Uo>> Uon
0.050
```

E3V - TIME DELAY SET-UP (programmable)

```
TI INDIP
xx.xx s
```

Set-up of the time-delay to the activation (TRIP) of the programmed output relays when the threshold operates. The time delay is programmable from 00.02 to 99.99 s.

E4V - ADDITIONAL TIME DELAY SET-UP (programmable)

```
TA Uo>>
xx.xx s
```

The additional time delay TA is programmable from 00.00 to 99.99 seconds; please note that at least one of the digital inputs should be programmed to activate time delay function (ref. G1 ÷ G6 - paragraph 5.8).

The additional time delay TA is added to the time delay TI to obtain the output relay trip when the TI+TA time expires.

The additional time delay TA will be added if the time delay TI is programmed at least equals to 50 ms (digital input acquisition time - 40 ms)

E5V - DIGITAL INPUT ACTIVE ON THRESHOLD (not programmable)

```
TA Uo>>
eeeeeee
```

It shows the digital input programmed to activate the additional time delay TA on the displayed threshold.

The parameter eeeeeeee can show one of the following values:

- DISABLED none of the digital inputs has been programmed to activate an additional time delay related to the threshold Uo>>
- DIG1 digital input DIG1 activates the TA delay on threshold Uo>>
- DIG2 digital input DIG2 activates the TA delay on threshold Uo>>
- DIG3 digital input DIG3 activates the TA delay on threshold Uo>>
- DIG4 digital input DIG4 activates the TA delay on threshold Uo>>
- DIG5 digital input DIG5 activates the TA delay on threshold Uo>>
- DIG6 digital input DIG6 activates the TA delay on threshold Uo>>

More than one digital input can activate the same additional time delay (e.g. DIG 1,3).

Please note that to activate the additional time delay at least one of the digital inputs should be programmed (ref. G1 ÷ G6 - paragraph 5.8).

5.6.6 ANSI 79 - Auto-reclosing function programming - (fig. 5)

The available settings for each parameter are listed in the table at paragraph 1.7. The programming of the auto-reclosing function will not be available when the under-impedance function has been selected (selection MIN Z-Y or MIN Z-D at FUNCTION - par. 5.4, ref. C1)

E1R - AUTO-RECLOSING FUNCTION ENABLED (programmable)

ANSI 79 ccc

ccc ON - enabled function
OFF - disabled function

E2R - ADDITIONAL RECLOSURES (programmable)

R.LENTE NRL n

n number of enabled additional reclosures (0 ÷ 4)

E3R - E4R - SHORT-TIME RECLOSING DEAD and RECLAIM TIME PROGRAMMING (programmable)

E3R
TRR xxx.x s

E4R
TN1 xxx.x s

TRR DEAD TIME short-time (first) reclosure
TN1 RECLAIM TIME short-time (first) reclosure

Example:

TRR 000.3 s

TN1 005.0 s

E5R - E6R - E7R - LONG DEAD TIME RECLOSURES PARAMETER (programmable)

E5R	E6R	E7R
TRL xxx.x s	TN2 xxx.x s	TD xxx.x s

TRL Long dead time
TN2 Reclaim time
TD Lockout time (inhibition of further reclosures)

E8R - E9R - E10R - E11R - THRESHOLDS ENABLING ON AUTO-RECLOSING FUNCTION (programmable)

The list of the thresholds that can be enabled on the auto-reclosing function depends on the enabled protection functions.

When the directional overcurrent function is enabled (ANSI 67), the following information is displayed:

E8R	E9R
67S1 cc 67S2 cc	67S3 cc

When the NON directional overcurrent function is enabled (ANSI 50), the following information is displayed:

E8R	E9R
50S1 cc 50S2 cc	50S3 cc

When the directional earth-fault function (ANSI 67N) is enabled (EARTH 1 mode), the following information is displayed:

E10R	E11R
67NS1 cc 67NS2 cc	67NS3 cc Uo>> cc

When the directional earth-fault function (ANSI 67N) is enabled (EARTH 2 mode), the following information is displayed:

E10R	E11R
67NSA cc	67NS3 cc Uo>> cc

cc ON - enabled function
OFF - disabled function

5.7 Output relays programming (fig. 5)

The session allows to program the activation of the output relays R1, R2, R3 or R4 on START or TRIP conditions for each threshold.

In the programming session are displayed only the active thresholds depending on selections.

Equivalent information and set-up related to relay R1 is available for the relays R2, R3 and R4 just changing the relay identification.

F1 - OUTPUT RELAY R1 QUIESCENT STATUS (programmable)

R1
NORM xxx

Programming of the R1 relay status when no START or TRIP conditions are activated.

NORM OFF normally de-energized (energized status on activation)

NORM ON normally energized (de-energized status on activation)

F2 ÷ F4 - OUTPUT RELAY ACTIVATION ON THRESHOLDS 67 - 50 (programmable)

When the directional overcurrent function ANSI 67 (selection DIREZ - par. 5.4, ref. C2) is enabled the following information is displayed:

F2	F3	F4
R1 67S1 xxxxxxxx	R1 67S2 xxxxxxxx	R1 67S3 xxxxxxxx

When the NON directional overcurrent function ANSI 50 (selection NO-DIREZ - par. 5.4, ref. C2) is enabled the following information is displayed:

F2	F3	F4
R1 50S1 xxxxxxxx	R1 50S2 xxxxxxxx	R1 50S3 xxxxxxxx

The parameter **xxxxxxxx** is selectable as the following:

START	instantaneous output relay R1 activation when one of the measured currents exceeds the programmed threshold
TRIP	output relay R1 activation when one of the measured currents exceeds the programmed threshold level for at least TI or TI+TA seconds
NONE	no activation related to thresholds

F5 ÷ F7 - OUTPUT RELAYS ACTIVATION ON THRESHOLDS ANSI 21 (programmable)

When the under-impedance function ANSI 21 (directional or NON-directional) is enabled the following information is displayed:

F5	F6	F7
R1 Z1 xxxxxxxx	R1 Z2 xxxxxxxx	R1 Z3 xxxxxxxx

Programming of the R1 output relay activation on the Z1, Z2 and Z3 thresholds (as threshold 67S1 - ref. F2).

F8 ÷ F12 - OUTPUT RELAYS ACTIVATION ON THRESHOLDS ANSI 67N - 59N (programmable)

F8	F9	F10	F11	F12
R1 67NS1 xxxxxxxx	R1 67NS2 xxxxxxxx	R1 67NS3 xxxxxxxx	R1 67NSA xxxxxxxx	R1 Uo>> xxxxxxxx

Programming of the R1 output relay activation on the ANSI 67N and ANSI 59N thresholds (as threshold 67S1 - ref. F2).

F13 - OUTPUT RELAYS ACTIVATION ON AUTO-RECLOSING FUNCTION - Relay R1

R1 ANS79 xxxxxxxx

The parameter **xxxxxxxx** is selectable between the following:

NO AZION	relay disabled on function ANSI 79
RICHIUS	relay enabled as switch-gear reclosing command
79 OK	relay activation on successful reclosing function
79 FR	relay activation on failed reclosing function
79 ON	relay activation when reclosing function in progress

F14 - TEST OF OUTPUT RELAYS R1

TEST R1 xxxxxxxx

See paragraph 4.4

5.8 Digital inputs function programming (fig. 6)

For each digital input one of the following functions are selectable:

- additional time delay (related to one or more thresholds - only time definite threshold)
- ON / OFF threshold (see paragraph 1)
- STATUS function (recording of measures on external command)
- pilot wire fault monitoring (only DIG2 monitors DIG1)
- switch-gear close command detection (ANSI 79 function)
- switch-gear open command detection (ANSI 79 function)

When the function of more than one digital input refers to a threshold, the priority will be the following:

- OF selection (threshold disabled) has the priority on TA function (additional time delay)

- b) the ALL selection (ALL the thresholds) has the priority on single threshold selection.

G1 - DIGITAL INPUT DIG1 SET-UP (programmable)

DIG1	cc
xxxxxxxx	

Programming of the function related to digital input channel 1 (DIG1).

Parameter cc: programming of the condition that activates the function related to digital input DIG1; the condition is selectable between HI and LO.

Parameter xxxxxx: programming of the function related to digital input DIG1; the following functions are selectable (only the active thresholds are presented - ref. E1 paragraph from 5.6.1 to 5.6.5):

NONE	no functions active related to digital input DIG1
TA 67S1	additional time delay on the threshold S1 ANSI 67
TA 67S2	additional time delay on the threshold S2 ANSI 67
TA 67S3	additional time delay on the threshold S3 ANSI 67
TA 50S1	additional time delay on the threshold S1 ANSI 50
TA 50S2	additional time delay on the threshold S2 ANSI 50
TA 50S3	additional time delay on the threshold S3 ANSI 50
TA Z1	additional time delay on the threshold Z1 ANSI 21
TA Z2	additional time delay on the threshold Z2 ANSI 21
TA Z3	additional time delay on the threshold Z3 ANSI 21
TA 67NS1	additional time delay on the threshold NS1 ANSI 67N
TA 67NS2	additional time delay on the threshold NS2 ANSI 67N
TA 67NSA	additional time delay on the threshold NSA ANSI 67N
TA 67NS3	additional time delay on the threshold NS3 ANSI 67N
TA Uo>>	additional time delay on the threshold Uo>> ANSI 59N
TA ALL	additional time delay on all thresholds
OF 67S1	threshold S1 disabled - ANSI 67
OF 67S2	threshold S2 disabled - ANSI 67
OF 67S3	threshold S3 disabled - ANSI 67
OF 50S1	threshold S1 disabled - ANSI 50
OF 50S2	threshold S2 disabled - ANSI 50
OF 50S3	threshold S3 disabled - ANSI 50
OF Z1	threshold Z1 disabled - ANSI 21
OF Z2	threshold Z2 disabled - ANSI 21
OF Z3	threshold Z3 disabled - ANSI 21
OF 67NS1	threshold NS1 disabled - ANSI 67N
OF 67NS2	threshold NS2 disabled - ANSI 67N
OF 67NSA	threshold NSA disabled - ANSI 67N
OF 67NS3	threshold NS3 disabled - ANSI 67N
OF Uo>>	threshold Uo>> disabled - ANSI 59N
OF RR	short-time (first) reclosing function disabled - ANSI 79
OF RL	long-time reclosing function disabled - ANSI 79
OF RICH	reclosing function disabled
STATUS	activation of status function (see paragraph 1)

CHINT	switch-gear CLOSE command detection (ANSI 79 function)
APINT	switch-gear OPEN command detection (ANSI 79 function)

G2 - DIGITAL INPUT DIG2 SET-UP (programmable)

DIG2	cc
xxxxxxxx	

Programming of the function related to digital input channel 2 (DIG2); the selections available are the same as presented for DIG1 (ref. G1) plus the following:

MONITOR	activation of pilot wire monitor function.
---------	--

G3 ÷ G6 - DIGITAL INPUTS DIG3÷DIG6 SET-UP (programmable)

DIG3	cc
xxxxxxxx	

Programming of the function related to digital input channel 3 (DIG3); the selections available are the same as presented for DIG1 (ref. G1).

5.9 Special function - voltage memory function (fig. 6)

When the relay is working as directional overcurrent relay (ANSI 67) or a directional impedance relay (ANSI 21) the VOLTAGE MEMORY function can be programmed by the operator.

When the function is active, if a close fault condition occurs and the reference voltage suddenly drops to very small values (lower than the threshold **USs>** related to the directional overcurrent thresholds **S1, S2, S3** or lower then threshold **UZs>** related to the directional under-impedance thresholds **Z1, Z2, Z3**) the protection relay keeps for 500 ms a memorized reference voltage corresponding to the system voltage prior to the fault and thus the relay can operate properly.

The memorized reference voltage is related to system frequency before the incidence of the fault.

MEMORIA
TENS. cc

cc ON - enabled function
OFF - disabled function

5.10 Parameter values visualization (fig. 6)

L1 ÷ L12 - THRESHOLDS STATUS

The actual status of each threshold or the status of the auto-reclosing function is displayed.

For each threshold are displayed the threshold identification (67S1, 67NS2 etc.) and the threshold status; the status can show one of the following values:

ON	active threshold
OFF	disabled threshold (programmed OFF at ref. E1 - see par. 5.6.1 - 5.6.5)
OFF_DIG	threshold programmed active but disabled by a digital input actual status (ref. G1 ÷ G6 - paragraph 5.8).

Examples:

67	S1
ON	

67	S2
ON	

67	S3
OFF	

M1 - M2 - OUTPUT RELAY STATUS

The actual status of each output relay is displayed; for each relay the following information is displayed:

- relay identification (R1, R2, R3, R4)
- relay status (ON - activated, OFF - non activated)

Note that ON/OFF do not necessary mean energized or de-energized (see ref. G1).

N1 - N2 - DIGITAL INPUT STATUS

The actual status of each digital input is displayed.

For each digital input the following information is presented:

- digital input identification (DIG1, DIG2, DIG3, DIG4, DIG5, DIG6)
- digital input status (HI or LO)

P1 ÷ P18 - MEASUREMENT DISPLAY

The actual values of the measures and of the computed parameters are displayed (currents, voltages, phase angles, impedances); the parameters related to disabled thresholds are not displayed.

For each measure the following information is displayed:

measure identification (I1, I2, I3, Io, U1)
 actual values expressed as In, Ion, Un, Uon, Zn etc.
 actual primary values

For the auto-reclosing function the following information is displayed:

ON	enabled auto-reclosing function
OF	disabled auto-reclosing function (programmed)
OF DIG	enabled auto-reclosing function temporarily disabled by a digital input
IN CORSO	auto-reclosing function in progress
FAIL RIC	failed reclosing function, function blocked

5.11 Events (fig. 7)

On the display are shown the memorized information related to the last 5 TRIP or STATUS events.

The 5 events are recorded and identified with a progressive number from 1 to 5; the more recent event shows a lower number.

Q1 - EVENT NUMBER

E1
cccccccc

The index E1, E2 ... E5 identifies the memorized event.

The parameter **cccccccc** gives information on the kind of event and it can show one of the following values:

NONE	no event memorized
67S1	event on trip threshold S1 ANSI 67
67S2	event on trip threshold S2 ANSI 67
67S3	event on trip threshold S3 ANSI 67
67NS1	event on trip threshold NS1 ANSI 67N
67NS2	event on trip threshold NS2 ANSI 67N
67NS3	event on trip threshold NS3 ANSI 67N
67NSA	event on trip threshold NSA ANSI 67N
50S1	event on trip threshold S1 ANSI 50
50S2	event on trip threshold S2 ANSI 50
50S3	event on trip threshold S3 ANSI 50
Uo>>	event on trip threshold Uo>> ANSI 59N
Z1	event on trip threshold Z1 ANSI 21
Z2	event on trip threshold Z2 ANSI 21
Z3	event on trip threshold Z3 ANSI 21
STATUS	information recorded on external command
POWER ON	switch-on of the protection relay (auxiliary power)
CHINT	switch-gear closing command acquisition
APINT	switch-gear opening command acquisition

For the events NONE and POWER ON no other information is presented: for the other events the following displays give more detailed information on the event.

For the events CHINT and APINT only the status of the last reclosing command (Q21), the digital input status (Q22 ÷ Q27) and the time and date (Q28 and Q29).

Q2 ÷ Q5 - TRIP THRESHOLD

The parameters of the threshold that caused the TRIP condition and their values are shown. This information is not presented on STATUS event.

Q2	current or impedance threshold
Q3	voltage threshold
Q4	characteristic angle (ΦX where X = 1, 2, 3, A)

Q5 sector width ($D\Phi X$ where $X = 1, 2, 3, A$)

For the threshold **SA** the Q2 and Q3 displays are doubled to present the values of the two current thresholds ($I_{o1}>$, $I_{o2}>$) and the two voltage thresholds ($U_{o1}>$, $U_{o2}>$).

When the thresholds are programmed as NON-directional, the information related to the angles is not presented (Q4 and Q5).

For the thresholds related to ANSI 50-51 the display of the voltage threshold (Q3) and the angle information (Q4, Q5) are omitted; for the threshold ANSI 59N the display of the current threshold (Q2) and the angle information (Q4, Q5) are omitted.

Examples related to **NSA** threshold:

Q11	Q3	Q2.bis	Q3.bis
E1 IA1> y.yyy In	E1 UA1> y.yyy Un	E1 IA2> y.yyy In	E1 UA2> y.yyy Un
	Q4	Q5	
	E1 ΦA +90°	E1 $D\Phi A$ 45°	

Q6 - ACTIVATED OUTPUT RELAYS

```
E1 RELAY
nnnnnnn
```

It shows the list of the output relay activated by the threshold trip.

Examples:

E1 RELAY 1, 3, 4	E3 RELAY 1, 4
---------------------	------------------

When no output relays have been activated (no relays programmed to TRIP on the threshold) the following message will be displayed:

```
E1 RELAY
NONE
```

Q7 - TOTAL TIME DELAY ON TRIP

```
E1 T-Tot
www.ww s
```

It is shown the total delay to the TRIP of the output relays from the overcurrent detection; when additional delays are activated, the change of the status of the digital input that controls the additional delay during the delay itself could bring to a total time different from the sum of the programmed delays. If the total time is greater than 999 seconds the display of tenths is omitted.

When the event is memorized on the external command (STATUS), the message N/A (Not Applicable) is shown instead of the number of seconds.

```
E1 T-Tot
N/A
```

Q8 - DIGITAL CHANNELS RELATED TO MEMORIZED EVENT

```
E1 DIG
1, 4, 6
```

The list of the digital inputs related to the memorized event is displayed (STATUS function command or additional time TA enabled - ref. par. 5.8).

If no digital inputs were activated, the message NONE is displayed.

Q9 ÷ Q20 - MEMORIZED MEASURES ON EVENT

The values of the measures at the event are displayed (currents or impedances, voltages and angles between each current and the related voltage); the values are expressed as relative terms (In, Ion, Zn, Un, Uon).

Examples:

Q9	Q14	Q20
E3 I1 n.nnn In	E3 U2 n.nnn Un	E3 Φ_o nnn°

The number of the presented information depends on the active functions (e.g. when ANSI 50-51 is selected, the information of impedance, voltage and angle is not presented).

Q21 - STATUS OF THE LAST RECLOSE COMMAND

```
E1 ANSI79
hhhhhhh
```

The status of the last reclosing command is presented; the parameter **hhhhhhh** can have the value:

RRR	Successful first (fast) reclosing	RRF	Failed first (fast) reclosing
RL1R	Successful 1st long time reclos.	RL1F	Failed 1st long time reclos
RL2R	Successful 2nd long time reclos	RL2F	Failed 2nd long time reclos
RL3R	Successful 3rd long time reclos.	RL3F	Failed 3rd long time reclos
RL4R	Successful 4th long time reclos.	RL4F	Failed 4th long time reclos

The information of a failed reclosing is presented when a protection function trips during a reclosing cycle; if no previous reclosing function has been executed the information NONE will be showed.

Q22 ÷ Q27 - DIGITAL INPUTS STATUS ON EVENT

E1 DIG1 vv	E1 DIG2 vv	E1 DIG3 vv
---------------	---------------	---------------

E1 DIG4 vv	E1 DIG5 vv	E1 DIG6 vv
---------------	---------------	---------------

The status of the digital inputs at the event are displayed.

The parameter **vv** can assume the value HI or LO.

Q28 - Q29 - DATE AND TIME OF THE EVENT

E1 Date dd/mm/yy	E1 Time hh:mm:ss
---------------------	---------------------

The date and time of the event are shown.

5.12 Trips counters (fig. 7)

In this section are displayed the total and partial counters of the output relay activation (on TRIP conditions) for each thresholds and the numbers of programming sessions with the date and time of the last confirmed programming session.

The total counters, the number of confirmed programming sessions and the date and time of the last confirmed programming session are not modifiable or resettable; the information related to the last programming session are used to control unauthorized access.

The partial counter can be modified following the standard set-up procedure for parameters as described at paragraph 4.2; the partial counters are immediately modified in the memory (the recorded values are immediately resetted without the need of the programming confirmation).

R1 ÷ R22 - TRIP COUNTERS

S1 P cccc	S1 T cccc
--------------	--------------

Display of the partial (P) and total (T) counters of the TRIP condition related to each threshold.

When the value exceed 9999 the counter starts again from 0000.

The counters are identified by the threshold name (67S1, 67S2, 67S3, 67NS1, 67NS2, 67NS3, 67NSA, 50S1, 50S2, 50S3, Uo>>, Z1, Z2, Z3); only the counter related to the active thresholds are shown (see selections to ref. C1 and C3)

R23 ÷ R25 - TOTAL PROGRAMMING SESSIONS AND DATE/TIME OF THE LAST PROGRAMMING SESSION

TOT PRG eeee	DATE PRG dd/mm/yy	TIME PRG hh:mm:ss
-----------------	----------------------	----------------------

Display of the number of confirmed programming sessions (from the factory set-up) and the date and time of the last confirmed programming session.

6 INSTALLATION

6.1 Supplied kit

RK VERSION - 19" rack installation (the proper rack is supplied by Seb)

- protection relay module ZFD8N with 2 rear sockets
- transparent front panel with push-buttons
- transparent front panel without push-buttons
- blister with items 1-2-3-4-5

MR VERSION - mini-rack installation

- mini-rack
- protection relay module ZFD8N with 2 rear sockets
- transparent front panel with push-buttons
- transparent front panel without push-buttons
- blister with items 1-2-3-4-5

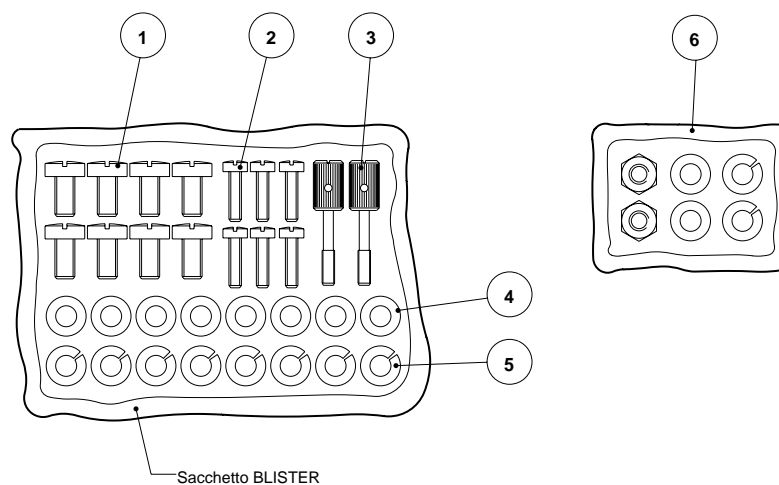

- 1) n° 8 screws to fix wire terminals of current circuits
- 2) n° 4 screws to fix the relay rear socket on the 19" rack (or on the mini rack) n° 2 screws to fix (optionally) the protection relay on the front of the 19" rack
- 3) n° 2 knobs to fix the transparent front panel
- 4) n° 8 washers to be used to fix wire terminals (current)
- 5) n° 8 growers to be used to fix wire terminals (current)

The knobs to fix the transparent front panel must be screwed through the panel the front panel itself; the operation will create a screw thread in the plastic material and the knobs will never be missed.

6.2 Cabling

INSERTIONS

Directional overcurrent	(ANSI 67)	figure 8
NON directional overcurrent	(ANSI 50-51)	figure 8 - current inputs only
Directional earth-fault	(ANSI 67N)	figure 8 - inputs I _o , U _o
Earth-fault overcurrent	(ANSI 51N)	figure 8 - input I _o , U _o
Directional under-impedance	(ANSI 21)	
NON directional under-impedance	(ANSI 21)	
Phase to phase voltages	figure 8	
Phase to earth voltages	figure 9	

For the terminal numbers on the rear sockets please refers to figure 10.

Current circuits

It is suggested to terminate the current wiring using eyelet terminals.

Minimum suggested wire cross section: 2,5 mm²

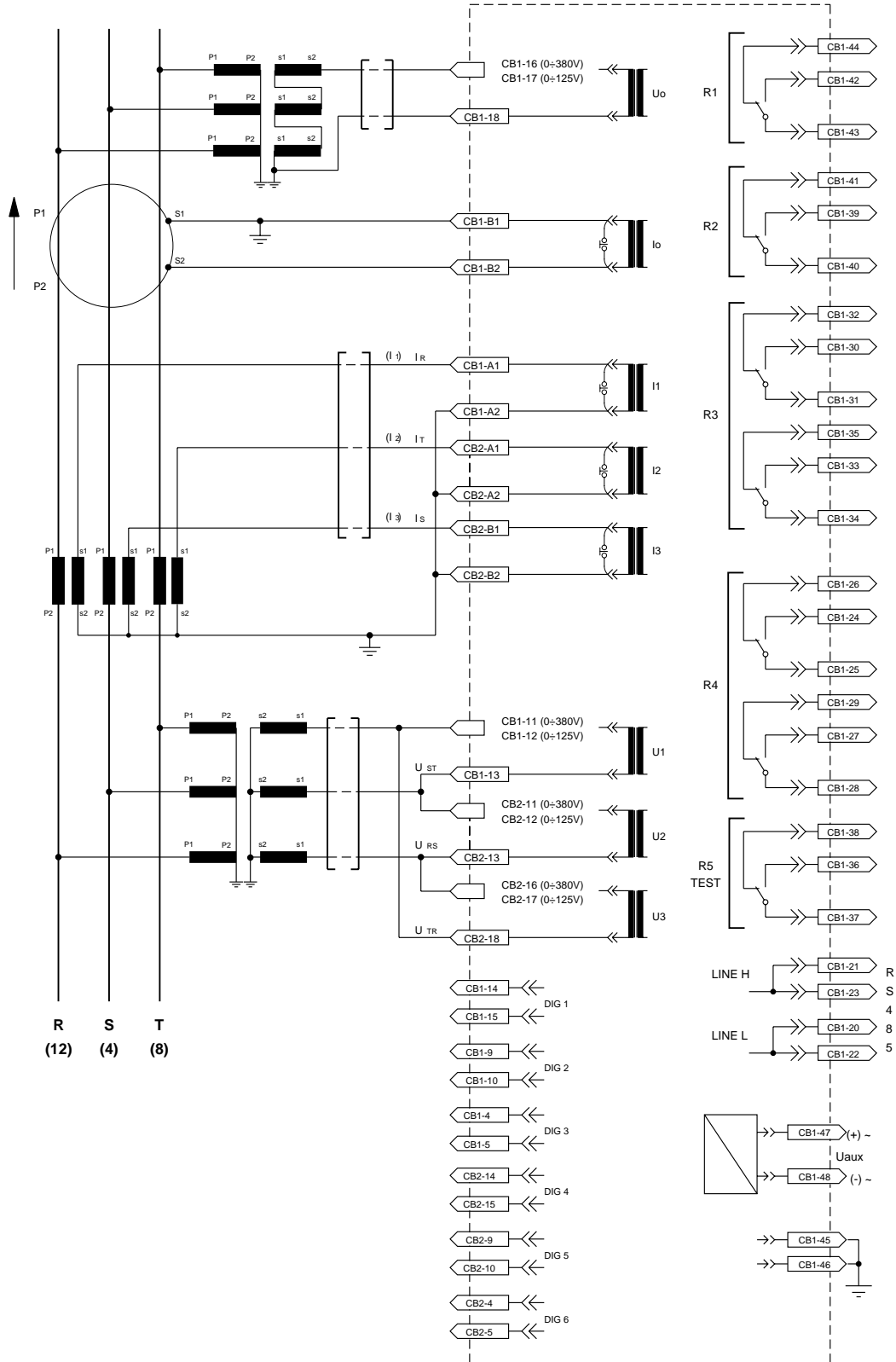

Insertion - Figure 8

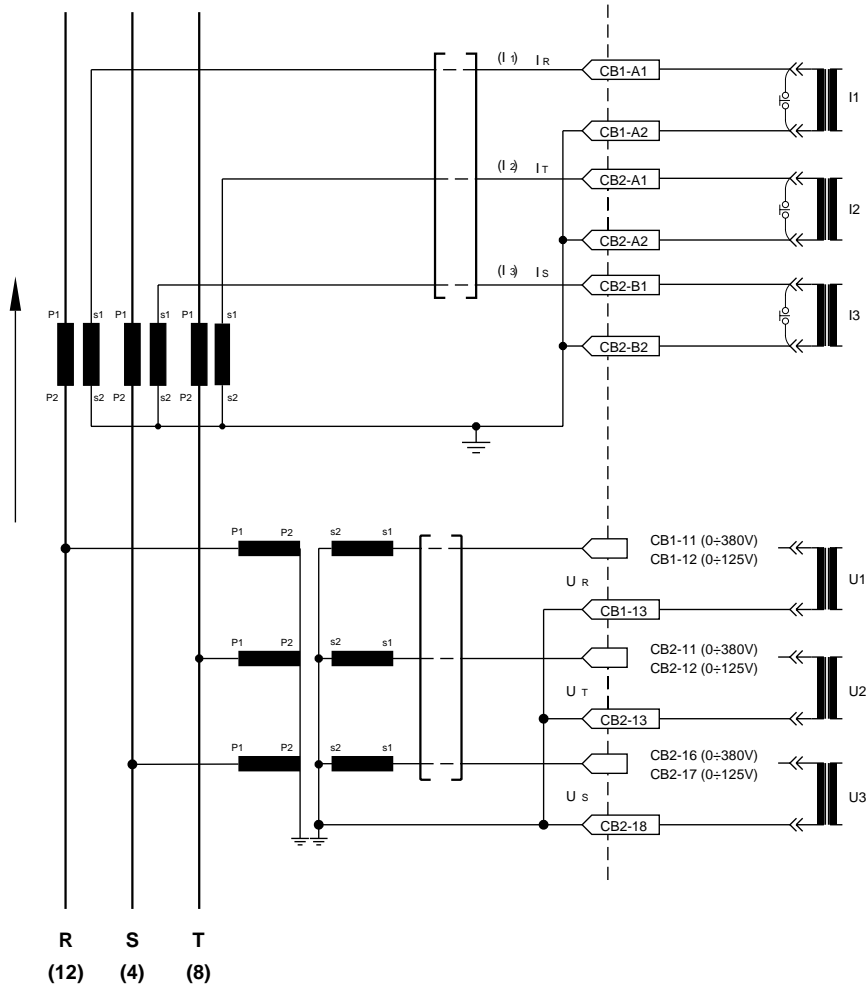

Insertion - Figure 9

Voltage circuits

It is suggested to terminate the voltage wiring using plug terminals.

Minimum suggested wire cross section: 1,5 mm²

With reference to the insertion diagram, the voltage input terminals must be selected as function of the programmed Un and Uon value.

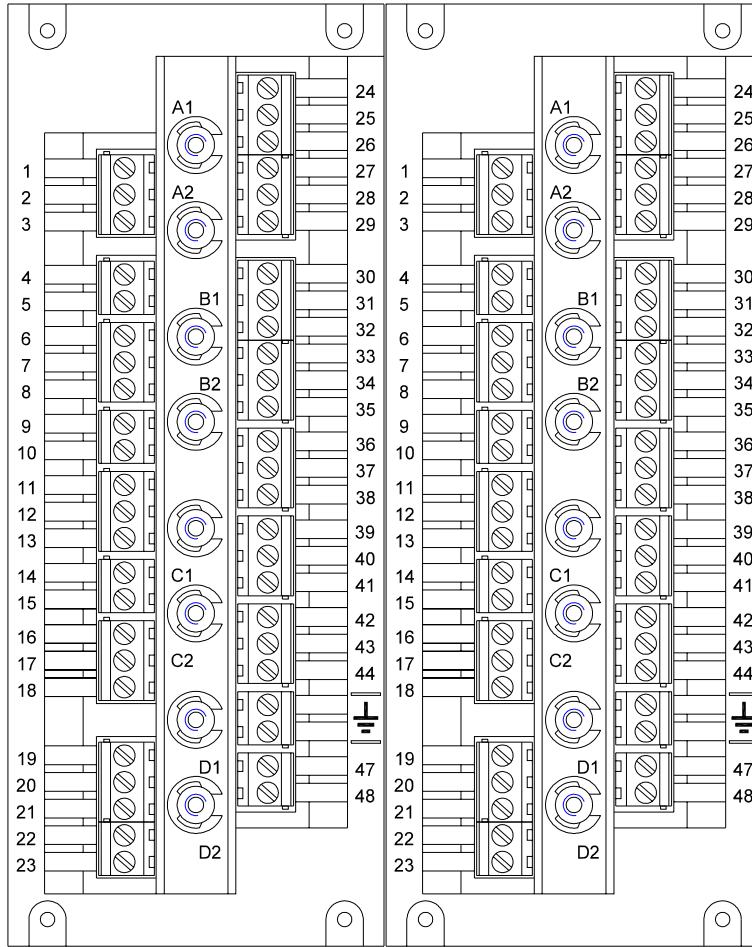

CB2

CB1

Terminal inputs position - REAR VIEW- Figure 10

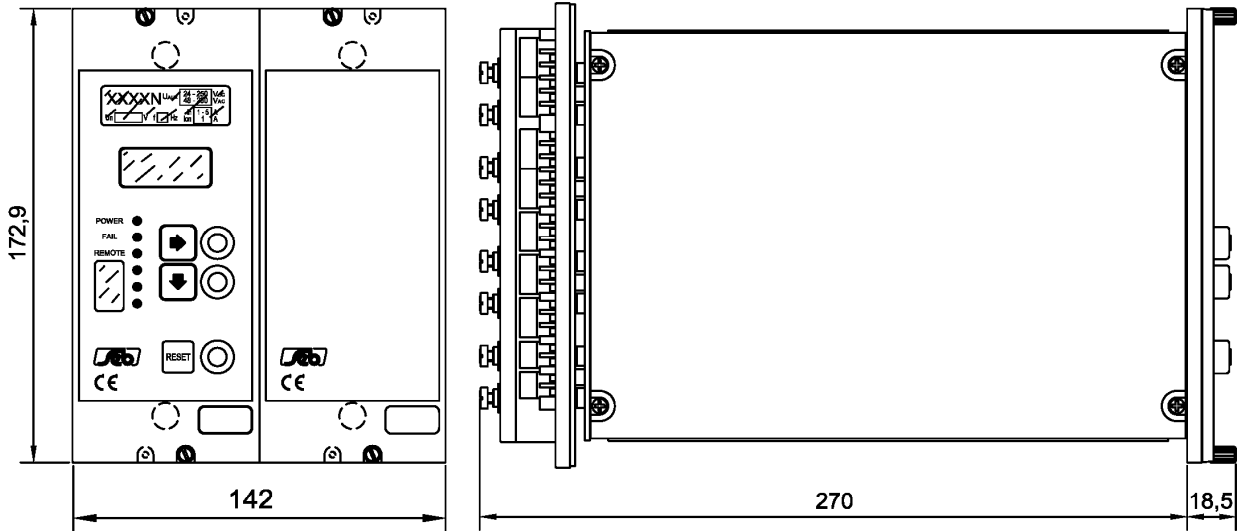

Dimensioni
meccaniche
Case outlines

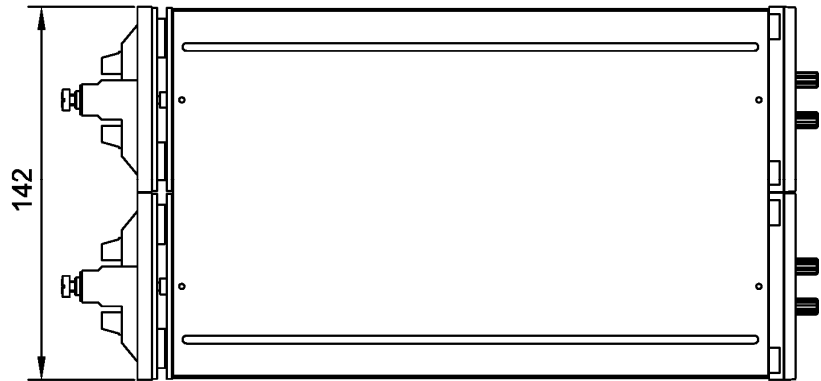

Dima montaggio da incasso
Flush mounting panel cut - out

Dimensioni frontali mini-rack per incasso
Mini-rack front sizes (flush mounting)
198.2 x 177 (4U) mm.

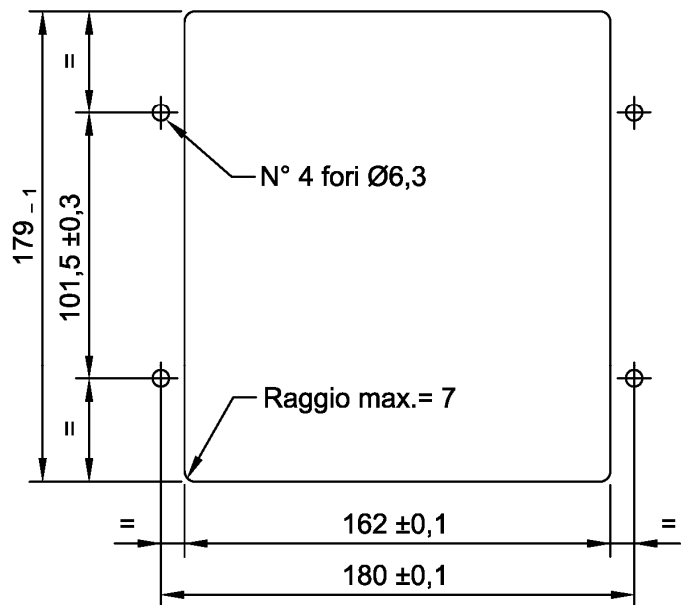

6.3 Relays R3 and R4 - Signaling / Command set-up

The protection relay is supplied with R3 and R4 relays configured as **SIGNALING RELAYS**, with 2 change-over output contacts with breaking capability equals to 0.2 A at 110 Vdc, L/R = 40 ms, 100000 operations.

Each R3 and R4 relay can be configured as **COMMAND RELAY** with 1 change-over output contact with breaking capability equals to 0.5 A at 110 Vdc, L/R = 40 ms, 100000 operations.

The new configuration is obtained with the following cabling:



6.4 RS485 serial communication port

The digital protection relay ZFD8N presents an insulated serial interface RS485 half-duplex that allow the multi-drop connection up to 31 protection units. There are available 2 selectable communication protocols (ref. B2 paragraph 5.3).

When the STANDARD SEB communication protocol is selected, the transmission speed is automatically selected between 300 to 9600 bauds and the protocol is ASCII-HEX.

When the MODBUS communication protocol is selected, the transmission speed can be programmed between 300 to 9600 bauds (ref. B3, par. 5.3).

To integrate the protection relay in control systems, the documentation related to the protocol is freely available on request.

It is suggested to use a shielded twisted pair AWG22; terminal 19 (not connected internally) can be used for shields connections.

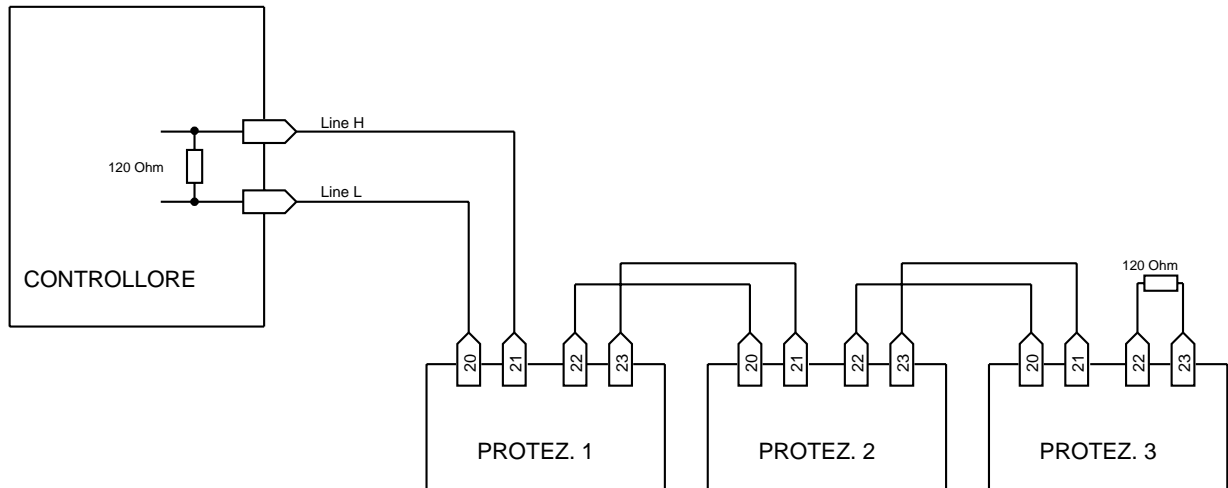

It is suggested to terminate the serial line with a resistance 120Ω , $1/4 \text{ W}$.

7 TIME DEPENDENT CURVES - IEC 255-4

Curva - Curve A

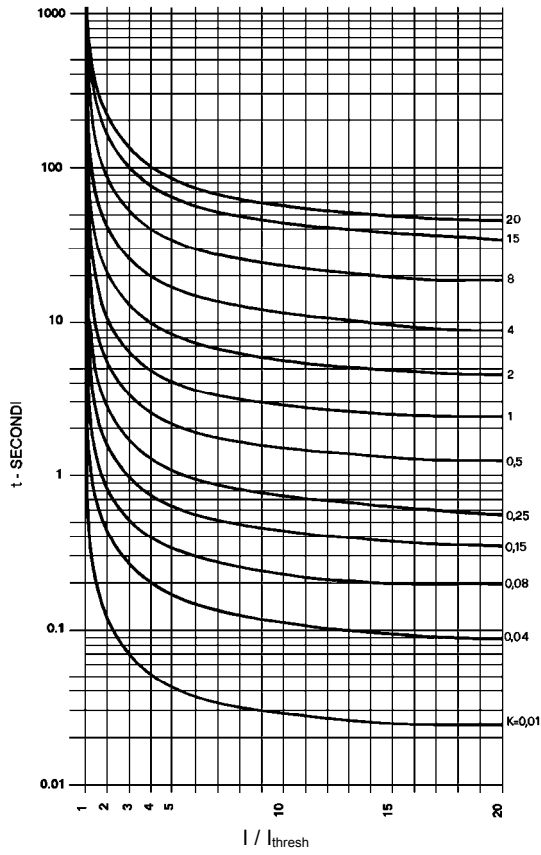

Curva - Curve B

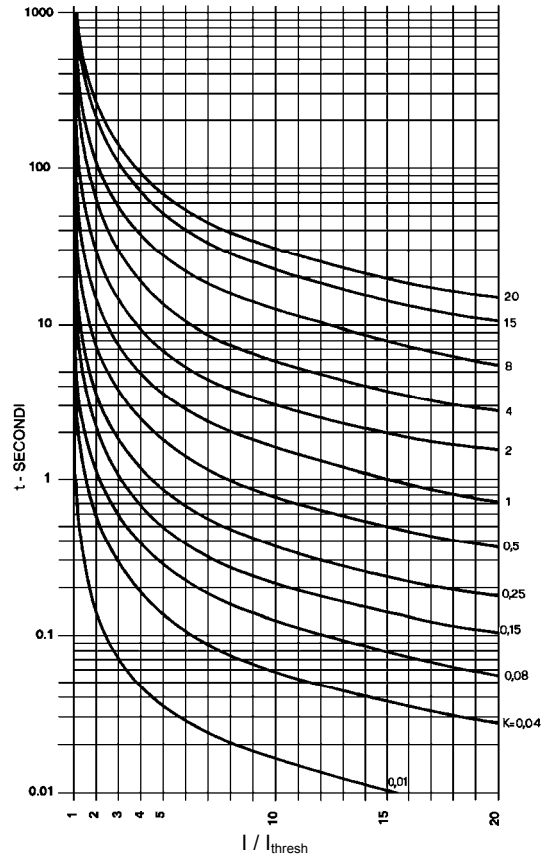

Curva - Curve C

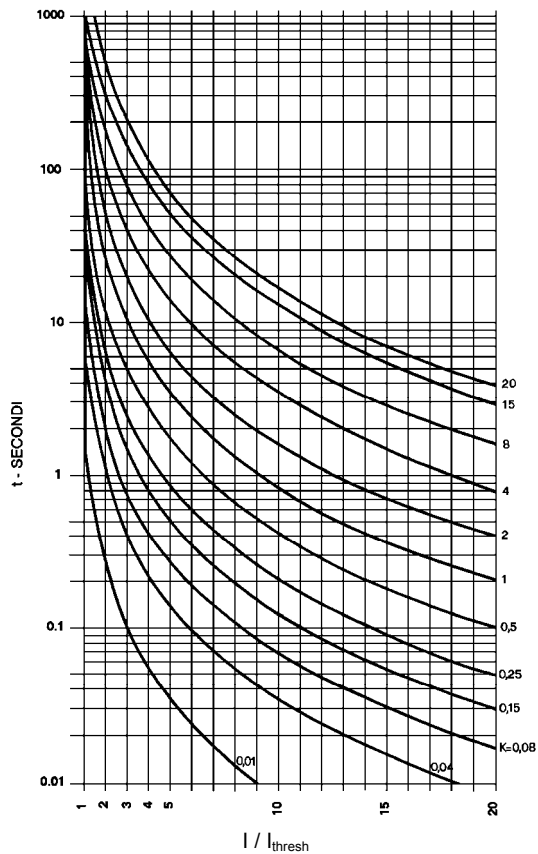

Time dependent characteristic

$$t = \frac{K_i * K}{\left(\frac{I}{I_{thresh}}\right)^\alpha - 1} + 0.02s$$

Curve IEC 255-4	A	B	C
K _i	0.14	13.5	80
α	0.02	1	2
K	Parameter 0.01 ÷ 20.00 s		
I / I _{thresh}	Ratio between the greatest measured current and I _{threshold}		

8 TECHNICAL DATA

Measuring inputs

Rated phase current (In)	1 A / 5 A programmable
Rated earth current (Ion)	1 A or 5 A
Thermal withstand continuously	4 In / Ion
Thermal withstand for 1 s	100 In / Ion
Rated voltage (Un, Uon) programmable	57.73 - 63.50 - 72.16 - 100 - 110 V 125 - 190 - 220 - 230 - 380 - 400 V
Thermal withstand continuously	2 Un
Thermal withstand for 1 s	2 Un
Rated frequency	50 / 60 Hz
Primary CT's current	1 - 18500 A
Primary VT's voltage	1 - 999999 V

Output contacts ratings

Number of relays (Note 1)	4 + 1
Rated current	5 A
Rated voltage	250 V
Contact configuration	change over
Breaking capability (Note 2)	
- tripping relays (R1, R2)	0.5 A
- signaling relays (R3, R4, R5) (Note 3)	0.2 A
Mechanical life	> 10 ⁶

Digital inputs

Number of inputs	6
External control voltage	as Uaux
Typical current (sink)	2 mA

Data transmission

Standard	RS-485 half duplex
Communication protocol	Mod-BUS - ASCII
Transmission speed	300 - 9600 bauds selectable
Optional	fibre optic module

Auxiliary supply

Range	24 ÷ 320 Vdc ± 20%
	48 ÷ 230 Vac ± 20%
Frequency (Vac)	47 ÷ 63 Hz
Burdens (min/max)	5 / 10 W

Environmental conditions

Operation	-10 / +60 °C
Transport and storage	-25 / +80 °C
Relative humidity (without condensation)	< 95%
Protection degree for flush mounting (mini rack)	IP 31
Weight	3.5 kg

- Note 1) The additional relay R5 is controlled by self-test program
- Note 2) Breaking capability at 110 Vdc, L/R 40 ms, 100.000 operations
- Note 3) The output contacts of R3 and R4 relays can be configured as signaling or tripping relays

9 TABLE

Table A Settings

ANSI	THRESHOLDS		Settings	Resolution
67	S1, S2, S3	Overcurrent Is1>, Is2>, Is3>	0.10 ÷ 30.00 In	0.01 In
50 - 51		Minimum voltage USs>	0.010 ÷ 1.200 Un	0.001 Un
67N	NS1, NS2, NS3, NSA	Earth overcurrent Io1>, Io2>, Io3>	0.005 ÷ 9.999 Ion	0.001 Ion
51N		Residual overvoltage Uo1>, Uo2>, Uo3>	0.004 ÷ 1.200 Uon	0.001 Uon
21	Z1, Z2, Z3	Under impedance Z1<, Z2<, Z3<	0.010 ÷ 9.999 Zn	0.001 Zn
		Minimum voltage UZs>	0.010 ÷ 1.200 Un	0.001 Un
All the directional thresholds	Φ	Characteristic angle	-180° ÷ +180°	1°
	$D\Phi$	Sector width	+15° ÷ +180°	1°
59N 59Vo	Uo>>	Residual overvoltage	0.004 ÷ 1.200 Uon	0.001 Uon
DELAYS				
Definite time		All thresholds	0.02 ÷ 99.99 s	0.01 s
Dependent time (S1, NS1)		Characteristic curves (as IEC 255-4)	A, B, C	--
		Characteristic constant	0.01 ÷ 20 s	0.01 s
All definite time thresholds		Additional delay	0.00 ÷ 99.99 s	0.01 s

SEB DIVISIONE ELETTRONICA E SISTEMI - UFFICIO COMMERCIALE
Via Segantini, 5 - 20825 BARLASSINA (MB) - **tel.** +39 0362 5669.1 - **fax** +39 0362 556622
web: www.seb-barlassina.it
mail to: servizio-clienti@seb-barlassina.it