

LR-series Installation Manual

REFERENCE
ZSE SOFTWARE & ENGINEERING
VIA M. IDIOMI 10/O
20090 ASSAGO (MI) ITALY

注意！

依據 低功率電波輻射性電機管理辦法

第十二條 經型式認證合格之低功率射頻電機，非經許可，公司、商號或使用者均不得擅自變更頻率、加大功率或變更原設計之特性及功能。

第十四條 低功率射頻電機之使用不得影響飛航安全及干擾合法通信；經發現有干擾現象時，應立即停用，並改善至無干擾時方得繼續使用。

前項合法通信，指依電信規定作業之無線電信。低功率射頻電機須忍受合法通信或工業、科學及醫療用電波輻射性電機設備之干擾。

Copyright

The copyright and ownership of this document belongs to TagMaster AB. The document may be downloaded or copied provided that all copies contain the full information from the complete document. All other copying requires a written approval from TagMaster AB.

Disclaimer

While effort has been taken to ensure the accuracy of the information in this document TagMaster AB assumes no responsibility for any errors or omissions, or for damages resulting from the use of the information contained herein. The information in this document is subject to change without notice.

1	Introduction	4
2	Safety Instructions	5
2.1	Warnings	5
3	General Information	6
3.1	Reader Overview	6
3.2	System Overview	9
3.3	ID-tags	9
3.4	Reader	10
3.5	Environmental Considerations	10
3.5.1	Electromagnetic Interference	10
3.5.2	Electromagnetic Interference in Cables	10
3.5.3	Lightning	10
3.5.4	Temperature	10
3.6	Technical Data	11
4	Installation	12
4.1	Preconditions	12
4.1.1	Tools	12
4.1.2	Cables	12
4.2	Mounting the Reader	13
4.3	Cable Connections	15
4.3.1	Relay Output, Group J1	18
4.3.2	Wiegand/Mag-stripe, Group J2	18
4.3.3	Power Supply, Group J31	19
4.3.4	External Tamper Switch, Group J32	19
4.3.5	RS485 Serial Communication Interface, Group J41	20
4.3.6	RS232 Serial Communication Interface, Group J42	20
4.3.7	Service Interface, Group J43	20
4.3.8	Isolated Inputs, Group J51	21
4.3.9	Isolated Outputs, Group J52	21
4.3.10	Ethernet, Connector P1	21
4.3.11	USB Host, Connector P2	21
4.3.12	Micro SD Memory Card Interface, Socket P3	21
4.4	Installation Test	22
4.4.1	Inspection	22
4.4.2	Verification	22
5	Maintenance	23
5.1	Trouble Shooting	23
6	Contact	25
6.1	Technical Support	25
6.2	Office	25
7	Glossary	26

1 Introduction

This section introduces the LR-series Reader and defines the target group for this manual.

The LR-series Reader is a long range Radio Frequency Identification (RFID) device for remote identification of ID-tags. The Reader can be used as a stand-alone reading device, or incorporated in more comprehensive identification systems through several standard interfaces.

The target group for the LR-series Installation Manual is personnel installing LR-series Reader, that is mounting the unit, installing the necessary cables, and performing an installation test. A sufficient knowledge of English is necessary.

The aim of the manual is to present an installation engineer, who has the necessary education and training, with the information needed to correctly install the LR-series Reader.

Note: This manual does not describe how to configure Reader application software, consult the corresponding software manual for more information.

2 Safety Instructions

This section describes general safety instructions and shows the system used for presenting safety information.

Read this manual carefully before installation work is performed and take notice of warnings in order to prevent injury and product damage.

Where local regulations exist, these are to be followed. The safety information in this manual is a supplement to local regulations. It is the responsibility of the local project manager to make certain that local regulations are known and followed.

The relevant manual (including this safety information) must be followed in any work performed on the TagMaster products or systems.

The use of TagMaster's genuine spare parts is recommended. TagMaster will not assume responsibility for any malfunction due to use of spare parts produced by a third party.

2.1 Warnings

Warnings are used throughout this manual to alert the reader to special instructions concerning a particular task or operation that may be hazardous if performed incorrectly or carelessly. The warnings are preceded by the common hazard symbol.



Figure 1 Hazard Symbol

The following two levels of warnings are used:

Warning!

Warning means that an accident may occur if the safety precautions are neglected. This type of accident may cause injury. It may also damage the product.

Caution!

Caution means that an accident may occur if the safety precautions are neglected. This type of accident may damage the product.

3 General Information

This section illustrates the Reader in particular and the identification system with its components in general. Environmental considerations as well as technical data are also described.

Check the contents of the shipment for completeness and possible damage. If the contents are damaged, file a claim immediately with the carrier and the TagMaster sales or service organisation. Alternatively notify a TagMaster representative in order to facilitate repair or replacement of the equipment.

3.1 Reader Overview

The LR-series Reader is designed for configuration with a wide range of input and output devices, including relays, isolated I/O, indicators, and a buzzer.

The Reader has several communication alternatives and is easily integrated using the following communication interfaces:

- Ethernet
- RS232
- RS485
- USB Host
- Wiegand/Mag-stripe
- Micro SD memory card

Note: the Reader application software may not be designed to support the use of these interfaces, consult corresponding software manual for further information.

The Reader is powered with a voltage ranging from +10 to +30 V DC.

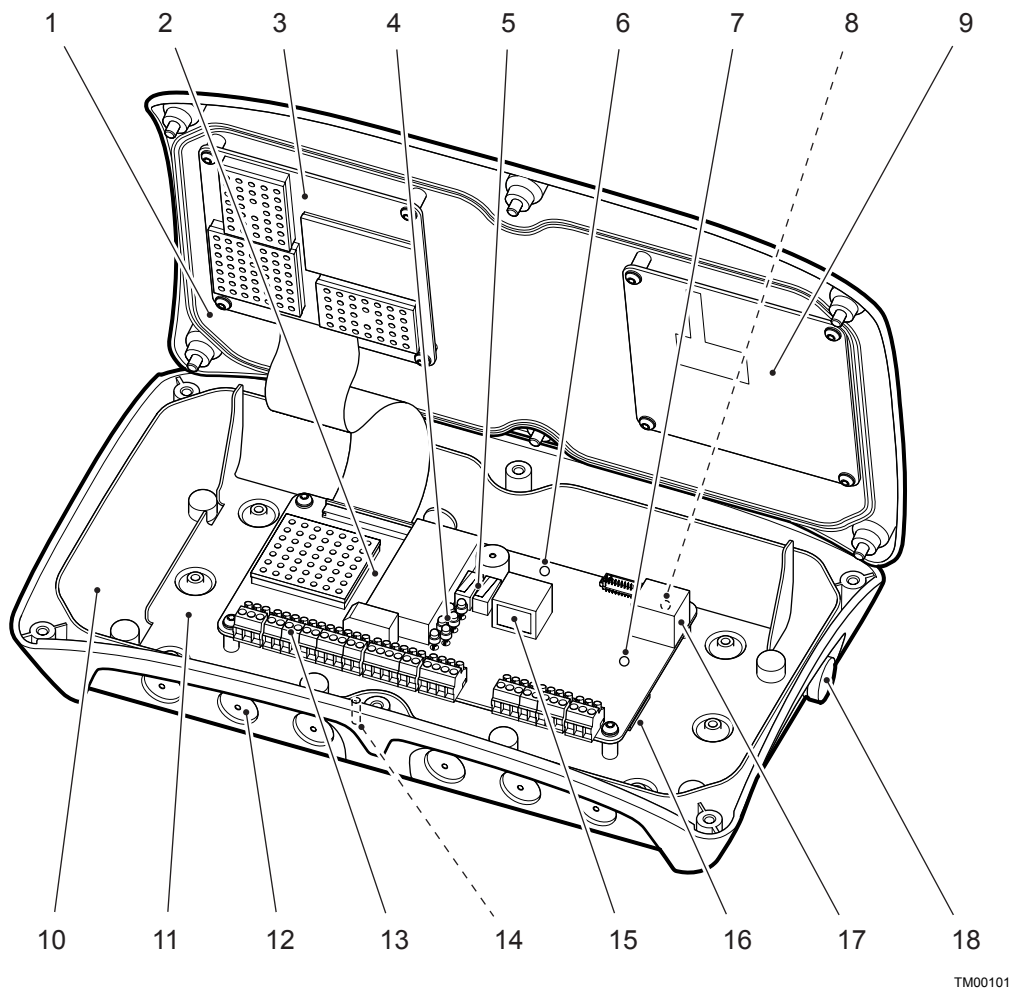

TM00101

Figure 2 Overview of the Reader

The following table describes the position of the components inside the Reader.

Table 1 The components of the Reader

Number	Component
1	Lid
2	Controller board
3	RF-unit
4	Externally-visible indicators
5	Tamper switches
6	Red system status indicator
7	Green system status indicator
8	Yellow system status indicator
9	TX-unit
10	Enclosure base
11	Chassis
12	Knock-out for cable entry
13	Terminal blocks
14	Ground screw
15	Ethernet connector with link state and activity indicators
16	Micro SD slot
17	USB host connector (intended for internal expansion)
18	Pressure balance membrane

3.2 System Overview

The two main elements of a TagMaster identification system are the Reader and the ID-tag. Peripheral elements are for example a host computer and other external devices, such as traffic lights and barriers.

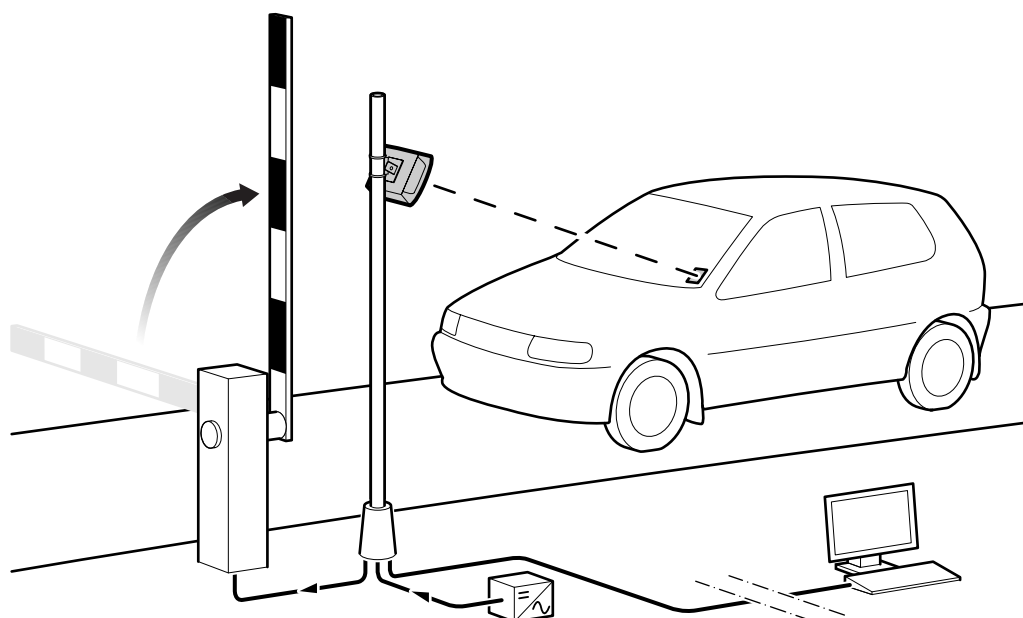

TM00102

Figure 3 System Overview

The figure above shows the overview of a TagMaster identification system with a pole-mounted Reader, an ID-tag mounted on the inside of a car windscreen, a host computer, a power supply, and a barrier.

3.3 ID-tags

An ID-tag is a device carrying ID information that can be read at a long distance. The actual reading range depends on the type of the Reader, the ID-tag, settings of the Reader, and environmental conditions.

Standard ID-tags have the shape of a credit card, but are slightly thicker. Each ID-tag has its own unique mark and it is possible to read many ID-tags concurrently. A lithium battery is used in the ID-tag to achieve a high communication speed and a long reading range.

There are two types of ID-tags called ScriptTags and MarkTags. ScriptTags can both be read from and written to, while MarkTags only can be read.

The front side of the ID-tags must be oriented towards the front side of the Reader. For maximum communication range, the front surface of the ID-tag should be parallel with the front side of the Reader. If the ID-tag is misaligned relative to the front side of the Reader, the communication range is reduced.

3.4 Reader

The LR-series Reader is a device for reading ID-tags using 2.45 GHz frequencies. In addition to reading, some Readers also have the capability to write information to ScriptTags (see separate data sheet for specific capabilities of the Reader). The Reader has built-in antennas for communication with ID-tags as well as various serial interfaces for communication with a host computer.

3.5 Environmental Considerations

The LR-series technology is a reliable solution for identification systems because it is unaffected by the normal electromagnetic background noise found in industries and elsewhere.

3.5.1 Electromagnetic Interference

Industrial noise is typically present in the kHz and low MHz frequency band. The LR-series is using 2.45 GHz frequencies, so typical industrial noise will not affect the communication.

3.5.2 Electromagnetic Interference in Cables

By using specified cables, proper shielding, and grounding as well as selecting a suitable communication interface, optimum communication reliability is ensured. For more information about cable specification see section 4.1.2 Cables.

3.5.3 Lightning

In order to protect the Reader from possible effects of lightning, additional surge protection on the inputs and outputs can be needed.

3.5.4 Temperature

For most applications, normal convection cooling is sufficient for the Reader. But if heat is generated close to the Reader, the use of forced cooling or heat shields should be considered.

3.6 Technical Data

The main difference between the LR-series Readers LR-6 and the LR-3 is the reading range and physical dimensions. Unless otherwise stated, the following specification applies to all LR-series Readers.

Table 2 Functional Specifications

Description	Specification
Reading range (LR-6)	0–6 m or 0–20 ft
Reading range (LR-3)	0–3 m or 0–10 ft
Power supply	+10 to +30 V DC
Power consumption	4.5 W
Current consumption	175/350 mA @ 24/12 V DC
Radio frequency range	CW: 2436.1–2464.1 MHz, channel 5–97 FHSS: 2400–2483.5 MHz
Tag data speed	Low 4 kbps and high 16 kbps
Ethernet	10/100 Mbps
Serial outputs	RS232, 2-wire or 4-wire RS485. Up to 115.2 kbps.

Table 3 Environmental Specifications

Description	Specification
Operating temperature range	–20°C to +60°C or –4°F to +140°F
Sealing	IP 65

Table 4 Mechanical Specifications

Description	Specification
Size (LR-6)	290 × 165 × 56 mm or 11.4 × 6.5 × 2.2 in
Size (LR-3)	228 × 145 × 50 mm or 8.9 × 5.7 × 2.0 in
Cable entry fittings (LR-6)	8 cable entry fitting holes with diameter 16 mm
Cable entry fittings (LR-3)	5 cable entry fitting holes with diameter 16 mm
Weight (LR-6)	0.95 kg or 2.1 lbs
Weight (LR-3)	0.74 kg or 1.6 lbs
Material	Enclosure is made of plastic
Colour (LR-6)	Lid is light grey and base is dark grey
Colour (LR-3)	Lid is medium grey and base is dark grey

4 Installation

This section describes the procedure of installing the Reader, that is mounting the Reader, installing the necessary cables, and performing an installation test. Read through this entire section before performing the installation.

The TagMaster system employs circular polarisation and can therefore also often be used when metal surfaces are in the vicinity of the antenna and the ID-tag, especially if the ID-tag is moving. In such cases however, adjustment of the Reader and the ID-tag positions and distance may be necessary to find the best arrangement.

4.1 Preconditions

The locations of Readers and ID-tags have been specified during the project planning phase, based on considerations of communication distances and movement speeds.

The cable paths and cable types have been determined during the project planning phase.

The power supply must comply with all relevant safety regulations.

The equipment must be disconnected from all voltage sources before any installation or service work is carried out. Capacitors inside the equipment can hold their charge even if the equipment has been disconnected from all voltage sources.

Caution!

Damage may be the result if the equipment is switched on when parts are removed from the controller board, or if a PCB is removed within one minute after switching off the equipment.

4.1.1 Tools

The following tools are necessary for installation:

- Screwdriver, Torx T20
- Screwdriver, 2.5 mm flat-bladed
- Short metal tube, diameter 16 mm
- Hammer
- Side cutter
- Wire stripper
- Crimping tool for ferrules

4.1.2 Cables

Cables are not supplied with the LR-series.

All cables must be shielded and suitable for the installation environment, for instance indoor or outdoor environment. Use flexible cables with stranded wire.

The terminal blocks used are Phoenix, type PT 1.5, which allow for a cable area of 0.2 to 1.5 mm² (AWG 26-14). Stranded wires must be fitted with a ferrule before being inserted in the termination blocks.

The cable for the RS485 interface must be a twisted pair cable and conform to the EIA RS485 standard.

A category 5 (CAT 5) cable is required for the Ethernet connection.

4.2 Mounting the Reader

Mount the Reader in a horizontal position. In exceptional cases, the Reader can be mounted in a vertical position.

Mount the Reader on a bracket and direct the front side of the Reader so that the reading lobe covers the positions of the ID-tags. The Reader identifies ID-tags within the reading lobe that expands in front of the Reader.

For optimal performance, tilt and rotate the Reader into a position so that the front side of the Reader is parallel with the front surface of the ID-tag to be read. Align the Reader so that the actual reading range is 60–70% of the specified maximum reading range.

The figure below shows a typical Reader installation, note that the installation details depend on site requirements and type of Reader.

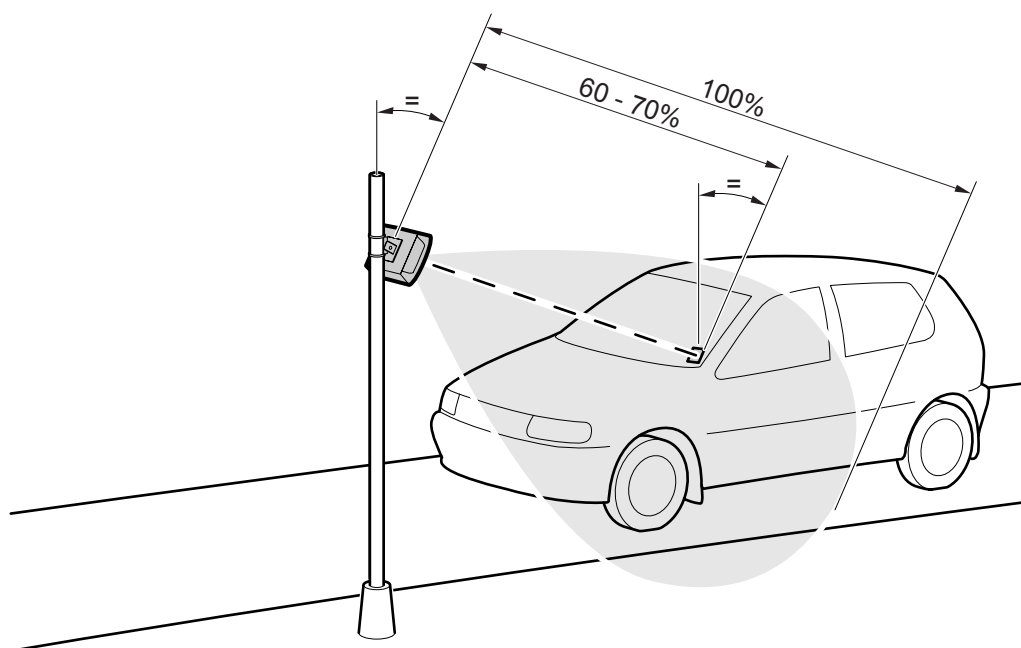

TM00103

Figure 4 Reading lobe

The LR-series Reader is prepared for mounting directly in a bracket on the back side of the Reader. The mounting holes enable the use of VESA 75 standard mounting brackets.

There are several M4 holes which can be used to fasten the reader onto the mounting bracket. The mounting holes are sealed at the base, so the fixing screw must not extend more than 8 mm into the reader.

Note: Do not drill any additional holes in the enclosure, as that would affect the sealing specification.

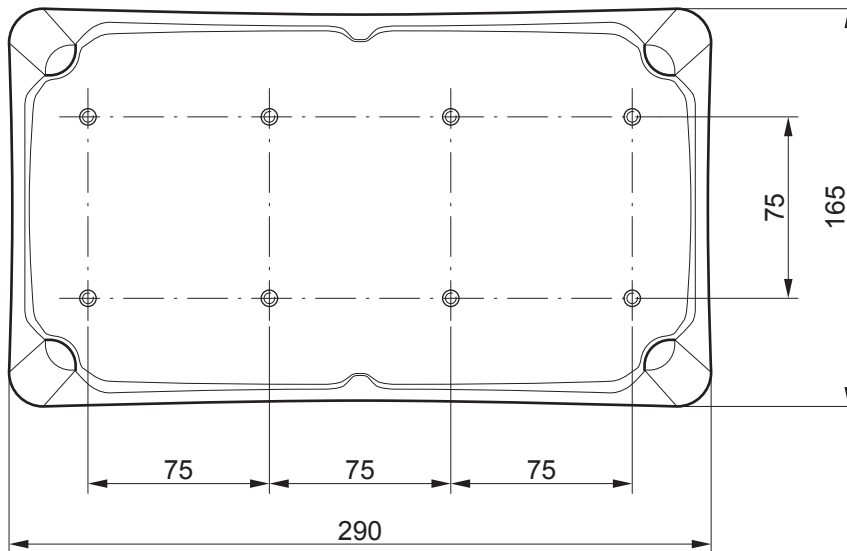

TM00104

Figure 5 LR-6 mounting hole layout on the back side of the Reader (units of measurement: mm)

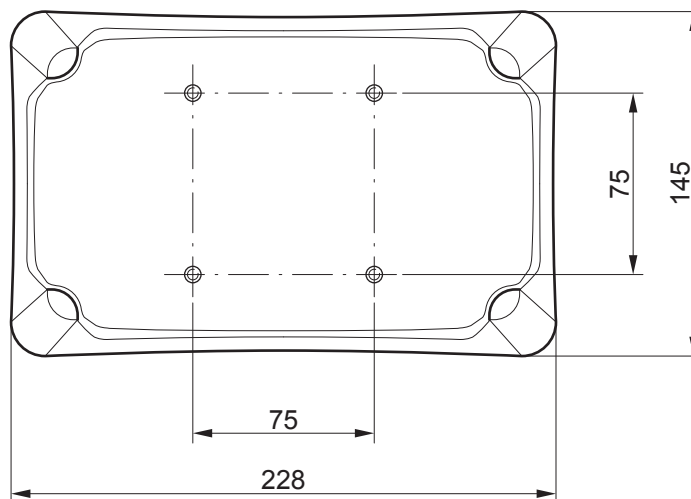

TM00105

Figure 6 LR-3 mounting hole layout on the back side of the Reader (units of measurement: mm)

The Universal Mounting Kit (Part No. 193600) from TagMaster enables the Reader to be mounted in a wide variety of positions and angles. The kit contains all parts needed for mounting the Reader on a wall or on a pole. The Universal Mounting Kit is suitable for both indoor and outdoor use. See separate data sheet for more details.

 **Caution!**

Never exceed the environmental and electrical limits as specified in section 3.6 Technical Data. Exceeding the limits can result in permanent damage to the Reader.

4.3 Cable Connections

The Reader is provided with knock-outs for incoming cables on both the horizontal and vertical edges. First and foremost use the cable entries on the horizontal edge of the Reader, even if the Reader is mounted in a vertical position.

Note: The Reader is certified for an installation of maximum four separate incoming cables. Do not exceed this maximum number.

1. Use a short 16 mm-diameter tube to remove the desired knock-outs. Using a hammer as illustrated in Figure 7, tap the tube sharply.
-
-

 **Caution!**

Keep the Reader closed when knocking-out the cable entries to prevent damaging the enclosure and be careful that the tube does not contact any components inside the Reader.

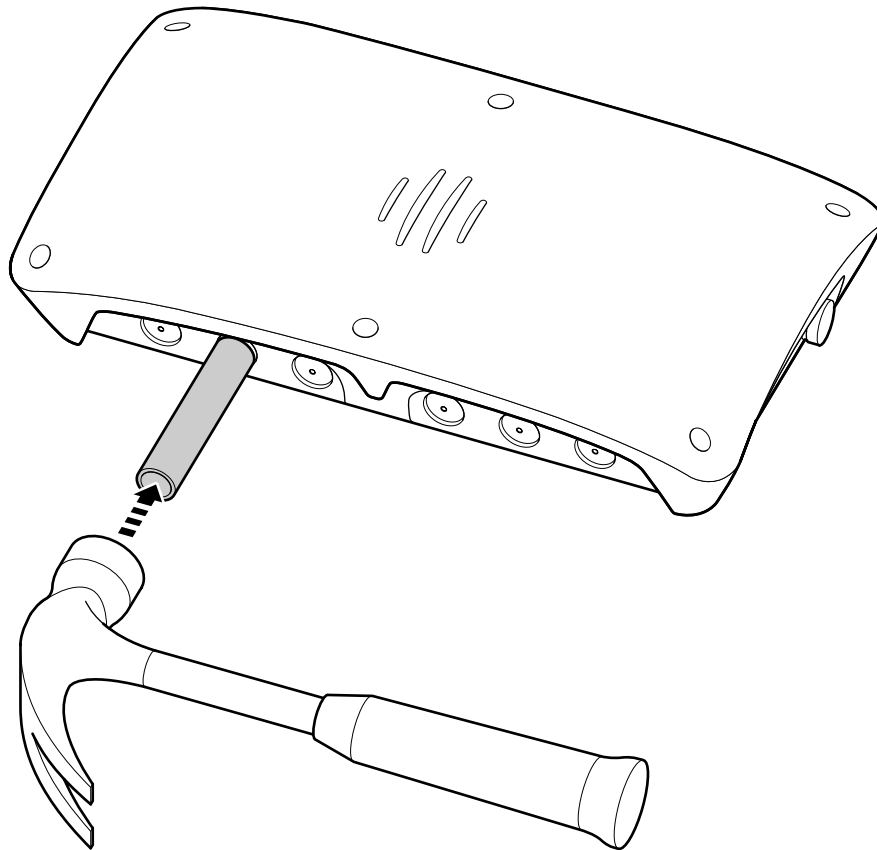

TM00106

Figure 7 Knocking out the cable entries

2. Open the Reader using a Torx screwdriver.
3. Insert metal cable glands into the holes.
4. Cut the power cable to a suitable length and pull it through the cable gland as illustrated in Figure 8.
5. Connect the shield of the power cable to earth at the power supply end. The shield functions as earth connection for the Reader.
6. Measure enough length of the cable to reach to the terminal block.
7. Strip the outer insulation and pull back the cable until the cable shield makes contact with the earthing fingers inside the gland.
8. Tighten the cable gland around the cable.

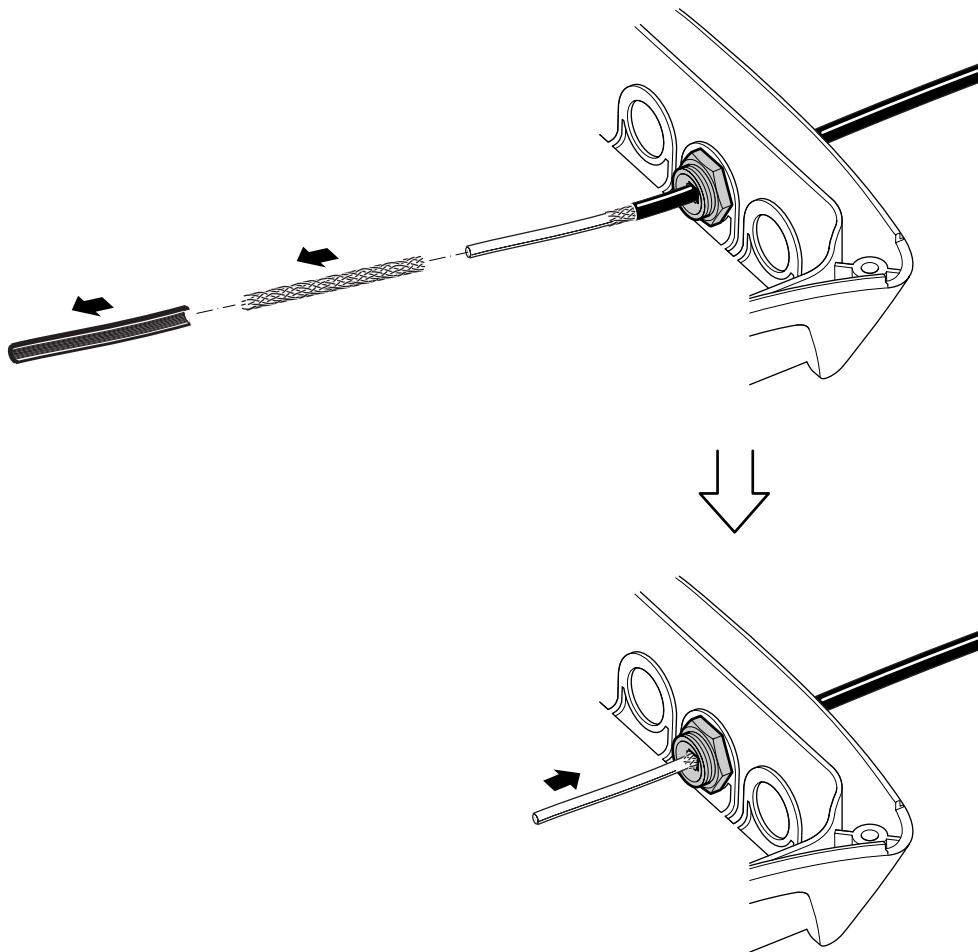

TM00108

Figure 8 Grounding the cable in the cable gland

9. Cut away excessive length of the cable shield, strip the ends of the conductors, and crimp a ferrule onto the stripped end of each conductor.
10. Connect the power cable to group J31 according to Table 8.
11. Make sure that the power source is turned off and connect the other end of the power cable to the power source.
12. Connect the remaining cables in the same manner. For connection of the Ethernet cable, see also section 4.3.10 Ethernet, Connector P1.

⚠ Caution!

Do not remove pressure balance membrane; it will compromise the IP classification.

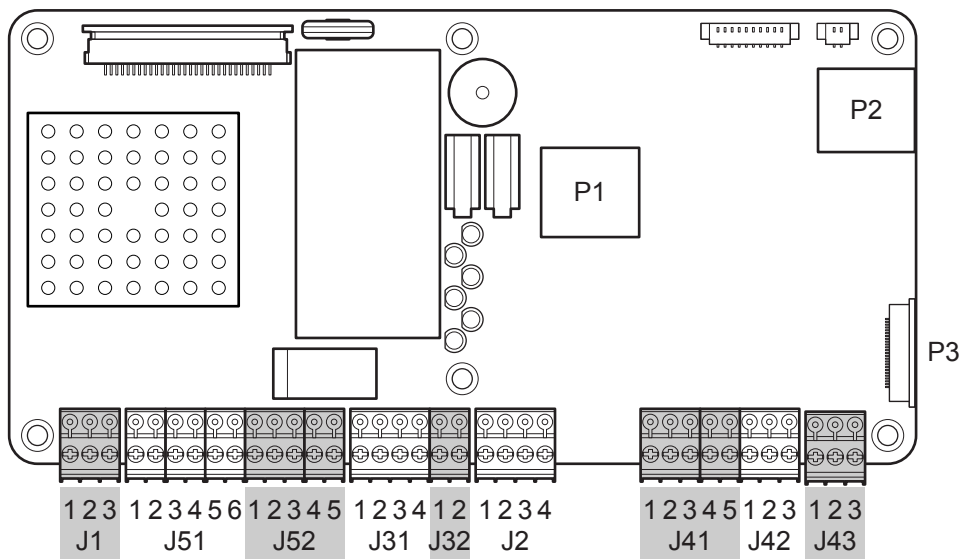

TM00107

Figure 9 Controller board with external connections

Note: It is possible to attach or remove the terminal block connectors inside the Reader for more convenient connection of the cables.

The terminals are grouped as specified in the sections below.

4.3.1 Relay Output, Group J1

The controller board has one relay output for heavy duty loads.

Table 5 Relay Output, Group J1

Pin	Signal	Description
1	RCOM	Common terminal or relay
2	ROPEN	Connected to RCOM when relay is open
3	RCLOSE	Connected to RCOM when relay is closed

4.3.2 Wiegand/Mag-stripe, Group J2

The controller board has an access control interface that supports both Wiegand and Mag-stripe protocols.

Table 6 Wiegand, Group J2

Pin	Signal	Description
1	D0	Wiegand 0 (zero) signal
2	D1	Wiegand 1 signal
3	CL	Card load signal
4	GND	Ground

Table 7 Mag-stripe, Group J2

Pin	Signal	Description
1	CLK	Mag-stripe clock signal
2	DATA	Mag-stripe data signal
3	LOAD	Card load signal
4	GND	Ground

4.3.3 Power Supply, Group J31

Pin 1 is internally connected to pin 3 and pin 2 is internally connected to pin 4. The purpose is to make it possible to feed power to any peripheral equipment. Use pins 1 and 2 for power supply connection.

Table 8 Power Supply, Group J31

Pin	Signal	Description
1	SPL	Positive DC supply input
2	RTN SPL	Negative DC supply input
3	SPL	Positive DC supply input, internally connected to pin 1
4	RTN SPL	Negative DC supply input, internally connected to pin 2

4.3.4 External Tamper Switch, Group J32

To protect the Reader from tampering, there are two mechanical tampering switches which break if the cover is opened. One tamper switch is connected internally to the controller board and will generate a software alarm when broken, and the other is an external tamper switch interface which can be connected to an external alarm loop.

Table 9 External Tamper Switch, Group J32

Pin	Signal	Description
1	TAMP A	When the tamper switch is open, TAMP A and TAMP B are connected.
2	TAMP B	

4.3.5 RS485 Serial Communication Interface, Group J41

The controller board has one RS485 serial interface for both 2-wire and 4-wire communication. RS485 supports multi-drop serial networks. The communication can be in both full duplex (4-wire) and half duplex (2-wire).

Note: If the installation requires long cables or high data speeds it may be necessary to use termination.

Table 10 Full Duplex (4-wire) RS485 Serial Communication Interface, Group J41

Pin	Signal	Description
1	TX+	Transmitted data, from Reader to Host
2	TX-	
3	GND	Ground
4	RX+	Received data, to Reader from Host
5	RX-	

Table 11 Half Duplex (2-wire) RS485 Serial Communication Interface, Group J41

Pin	Signal	Description
1	TX/RX+	Transmitted and received data, to and from Host
2	TX/RX-	
3	GND	Ground
4	NC	Not used
5	NC	

4.3.6 RS232 Serial Communication Interface, Group J42

The controller board has one RS232 serial interface.

Table 12 RS232 serial communication interface, Group J42

Pin	Signal	Description
1	TX	Transmitted data, from Reader to Host
2	RX	Received data, to Reader from Host
3	GND	Ground

4.3.7 Service Interface, Group J43

The service interface is used for maintenance and configuration of the Reader. Do not use the service interface as a regular system interface.

Table 13 Service Interface, Group J43

Pin	Signal	Description
1	TX	Transmitted data, from Reader to Host
2	RX	Received data, to Reader from Host
3	GND	Ground

4.3.8 Isolated Inputs, Group J51

The Reader has three isolated optocoupler inputs which are protected from noisy environments.

Table 14 Isolated Inputs, Group J51

Pin	Signal	Description
1	IN 1A	Input signal 1
2	IN 1C	Input reference 1
3	IN 2A	Input signal 2
4	IN 2C	Input reference 2
5	IN 3A	Input signal 3
6	IN 3C	Input reference 3

4.3.9 Isolated Outputs, Group J52

The reader has two open collector outputs.

Table 15 Isolated Outputs, Group J52

Pin	Signal	Description
1	OUT 1C	Output 1 collector
2	OUT 1E	Output 1 emitter
3	OUT SPL	External supply voltage for the outputs
4	OUT 2C	Output 2 collector
5	OUT 2E	Output 2 emitter

4.3.10 Ethernet, Connector P1

An RJ45 connector labelled P1, with two internal indicators, is provided for Ethernet connection. The clip for detaching the cable faces upwards from the controller board surface to allow mid-board mounts.

The Ethernet connector has eight pins and the wire scheme is based on the T568A standard. The pins are wired straight through the cable, that is, pins 1 through 8 on one end are connected to pins 1 through 8 on the other end.

Note: The RJ45 connector will not pass through the cable gland. Pass the Ethernet cable through the cable gland, before crimping the connector on the cable.

4.3.11 USB Host, Connector P2

USB devices are connected using a standard USB type A connector.

4.3.12 Micro SD Memory Card Interface, Socket P3

A standard micro SD memory card socket is used. The card socket is placed on the underside of the controller board.

4.4 Installation Test

After having completed the installation as described in previous sections, carry out an installation inspection and verification. If an error occurs, the guidelines in section 5.1 Trouble Shooting may be valuable.

4.4.1 Inspection

Ensure that there are no metal objects between or close to the Reader and the ID-tag in the positions where communication is to take place.

Ensure that the Reader and the ID-tag are aligned properly. Avoid communication at maximum specified distance and misalignment, see Figure 4.

Ensure that the Reader is not placed in a location where it is exposed to excessive heat or electromagnetic interference.

4.4.2 Verification

The installation verification is as follows:

1. Keep the lid of the Reader open.
2. Switch on power to the Reader.
3. Observe the behaviour of the system status indicators on the controller board. The yellow, red, and green system status indicators will be on continuously.
4. The green system status indicator will start flashing after about 30 seconds, indicating that the software is running.
5. The buzzer will sound a short beep and the red system status indicator will start flashing when the hardware is initiated and running.
6. If the Reader is connected to an Ethernet network, the green link state indicator on the Ethernet connector will be on to indicate a 100 Mbps connection or off to indicate a 10 Mbps connection. The yellow activity indicator on the Ethernet connector will be flashing to indicate present network communication.

If the hardware fails to initiate, the Reader will make two more attempts to initiate it. Each attempt is indicated by a short beep. If the hardware does not initiate after three attempts, contact TagMaster, see section 6.1 Technical Support.

If specific Reader application software is used, consult the corresponding software manual for more information concerning installation test.

Close the Reader, fit the lid to the base enclosure, and fasten the screws on the lid. Tighten the screws to a torque of 1 Nm in order to seal the enclosure without destroying the gasket. Clean up the site and dispose of any debris from the work.

5 Maintenance

This section describes the maintenance procedure for the Reader and how to solve the most common problems encountered during installation.

If the reader malfunctions, contact TagMaster Support, see section 6.1 Technical Support. Never try to dismantle any components inside the Reader, since there are no components inside the Reader that can be serviced by an installation engineer. Any such unauthorized alterations to the Reader will invalidate the warranty.

5.1 Trouble Shooting

The following table describes the most common problems encountered during installation as well as adequate solutions.

Three system status indicators on the controller board inside the Reader show the status of the unit as illustrated in Figure 2. The table below explains the different indicator meanings.

Table 16 System status indicators

Colour	Mode	Indicates
Yellow	On	Power on
	Off	Power off
Green	Flashing	System SW running
	Initially on	System SW loading
	Persistently on	System SW fault
	Off	System SW fault
Red	Flashing quickly	HW initiated and running
	On	Initiation process
	Off	HW not initiated

The link state indicator and the activity indicator on the Ethernet connector inside the Reader show the status of the network communication as explained in the table below.

Figure 10 Ethernet indicators

Colour	Mode	Indicates
Green	On	100 Mbps connection
	Off	10 Mbps connection
Yellow	Flashing	Present communication
	On	Link exists
	Off	No communication

The following table describes the most common problems encountered during installation and proposed solutions.

Table 17 Most common problems

Problem	Solution
Yellow system status indicator is off	Check the power supply.
Green system status indicator is on or off	Switch off the power supply, switch it on again, and wait 30 seconds. This can be done by pulling the J31 terminal block off the board and putting it back again. If the Reader fails to start again, contact TagMaster support.
Red system status indicator is on or off	Switch off the power supply and switch it on again. This can be done by pulling the J31 terminal block off the board and putting it back again. If the Reader fails to start again, contact TagMaster support.
Yellow Ethernet indicator is off	Check the network connection.

6 Contact

For any further inquiries, please contact your reseller.

6.1 Technical Support

6.2 Office



7 Glossary

The glossary lists abbreviations and acronyms used in this manual.

AWG	American Wire Gauge
CW	Continuous Wave
DC	Direct Current
FCC	Federal Communications Commission
FHSS	Frequency-Hopping Spread Spectrum
Host	The external intelligence, for instance workstation or server, which acts as master of a Reader or a set of Readers
ID-tag	ID-carrier in the TagMaster system, which is readable and writable using a Reader
Mag-stripe	Card reading protocol used for reading magnetic stripe cards
PCB	Printed Circuit Board
Reader	TagMaster LR-series ID-tag reader
RF	Radio Frequency
RFID	Radio Frequency Identification
Tamper switch	Switch that detects unauthorized access to the unit
USB	Universal Serial Bus
VESA	Standard for mounting flat panel monitors and TVs, also known as Flat Display Mounting Interface (FDMI)
Wiegand	Trade name for a technology used in card readers and sensors, particularly for access control applications